

## REMOVING-REFITTING THE ENGINE

- Remove the front lid.  
*Removing-refitting the front compartment lid*
- Remove the spare wheel housing.  
*Removing /refitting the spare wheel housing*
- Working from inside the engine compartment, loosen the cap for the hydraulic steering reservoir.



- Loosen the water nourice cap.



CLICK HERE TO **DOWNLOAD** THE COMPLETE MANUAL

- Thank you very much for reading the preview of the manual.
- You can download the complete manual from: [www.heydownloads.com](http://www.heydownloads.com) by clicking the link below



- Please note: If there is no response to CLICKING the link, please download this PDF first and then click on it.

CLICK HERE TO **DOWNLOAD** THE COMPLETE MANUAL

- Remove the heat shield for the spare wheel housing by unscrewing its six screws.



- Release the clutch hydraulic hose from its seven metal clips.

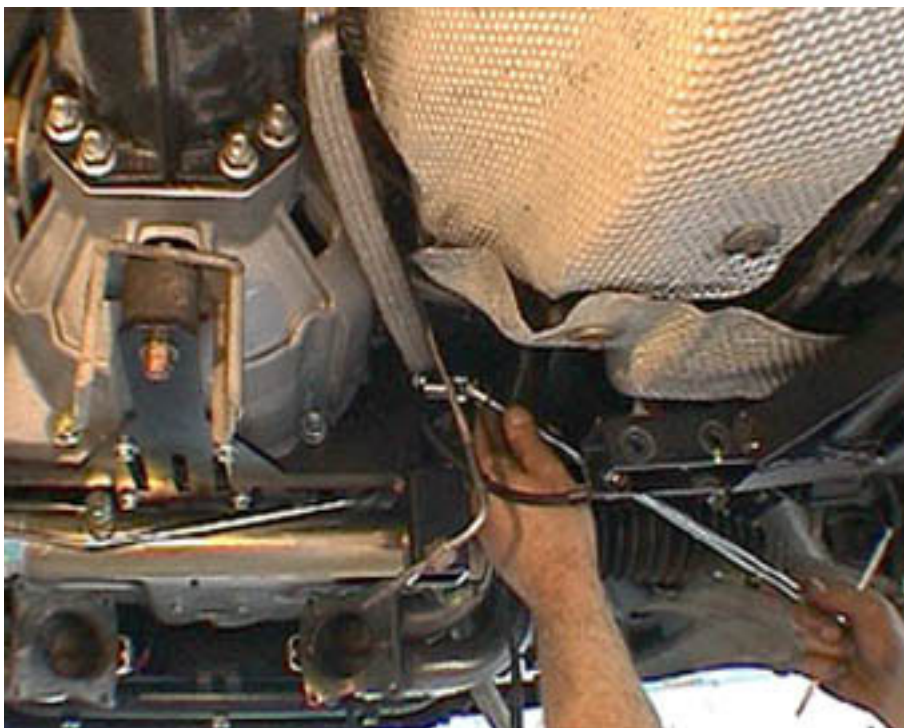

- Working from inside the engine compartment, detach the water nourice hoses; The nourice hoses must also be freed from the clips securing them to the engine compartment.



- Unscrew the two screws securing the water nourice to the chassis.



- Unscrew the screw securing the window fluid reservoir support clip to the car body.



- Remove the rear gravel guard from the front RH wheelhouse.

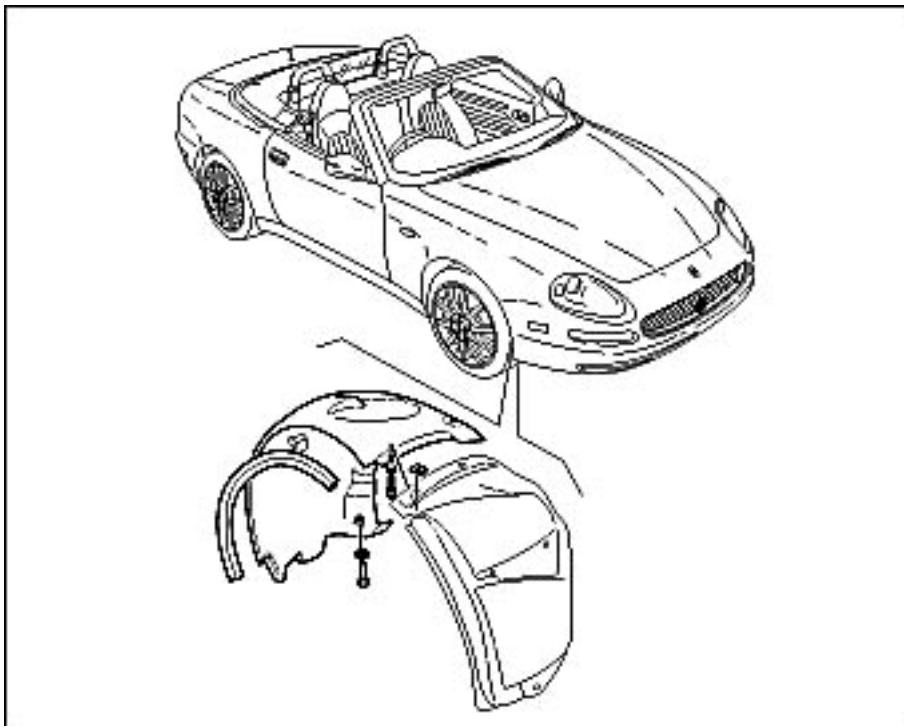

- The level check must be carried out with the car on the flat and the engine warm and idling. The oil level must be between the **MIN** and **MAX** reference points on the dipstick **C**. The gap between **MIN** and **MAX** corresponds to about 1 litre of oil.

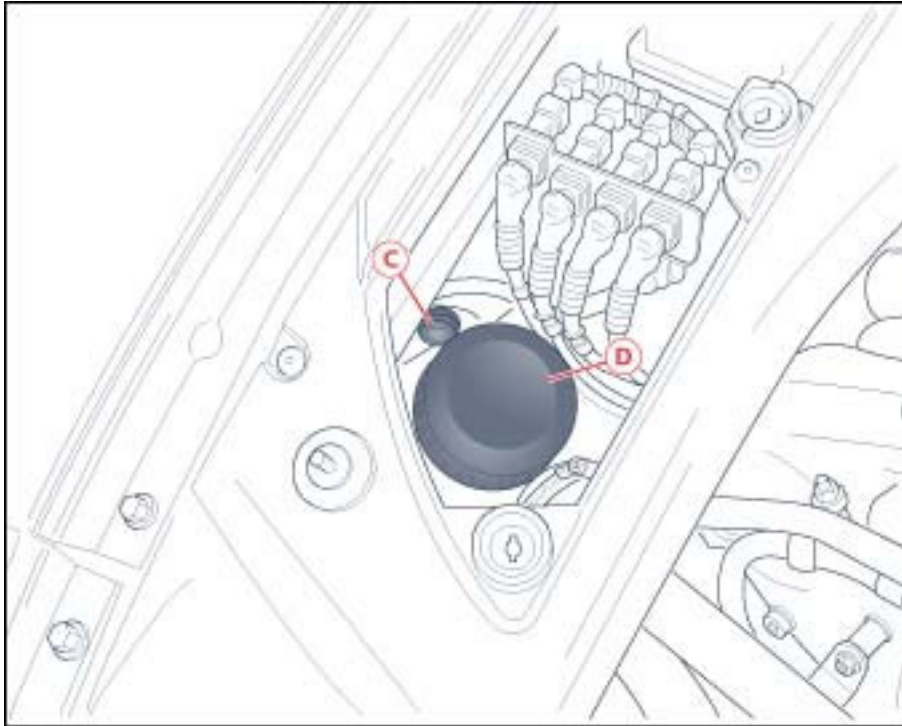

**IMPORTANT**

Do not top up with oil having characteristics other than those of the oil already used in the engine.

**CAUTION**

The engine oil used and the oil filter replaced contain substances that are dangerous for the environment. For replacing the oil and the filters you are advised to contact the Maserati Service Network, where all the necessary equipment is available to dispose of the used oil and filters in compliance with the regulations in force and in an environment-friendly manner.

- Drain the oil from the reservoir by undoing the relative screw.



- Detach the two cooling system fan connectors and the fan speed sensor.

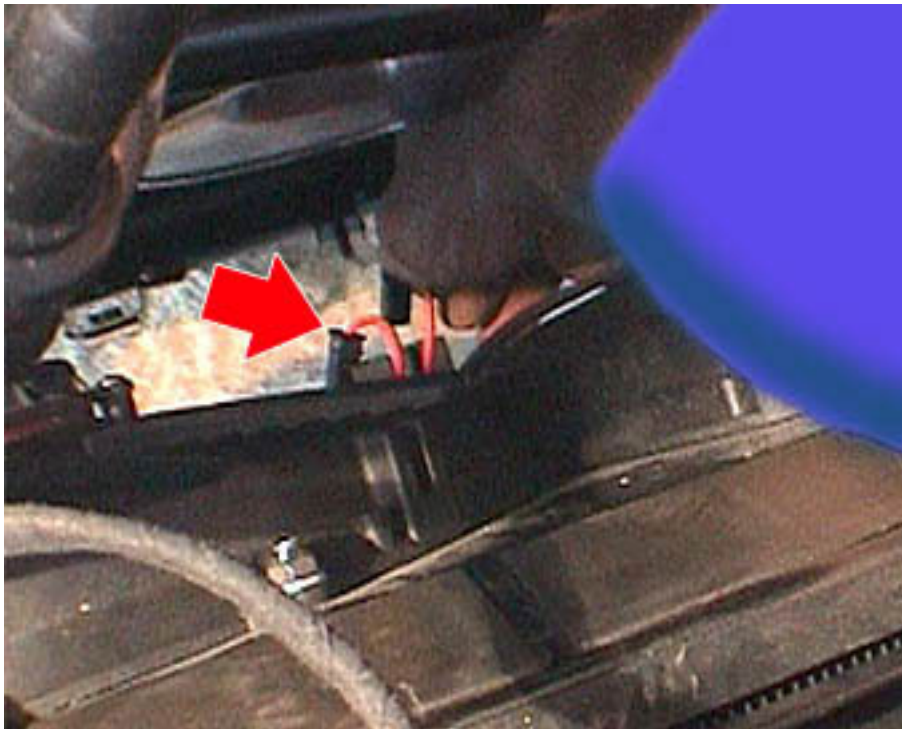

- Unscrew the screws securing the condenser from the water radiator.



- Unscrew the screw securing the duct to the radiator.

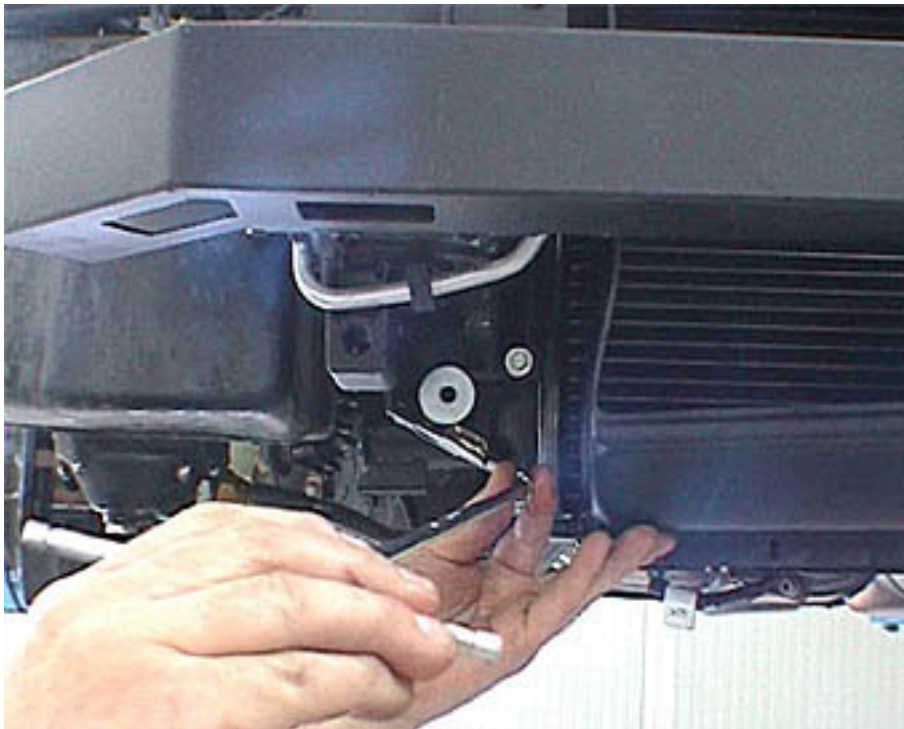

- Remove the radiator.  
**When refitting, proceed in reverse order**

- Unscrew the clamp Unscrew the clamp connecting the central exhaust line and the terminals.



- Unscrew the screws securing the central exhaust anti-vibration supports from the gearbox housing.

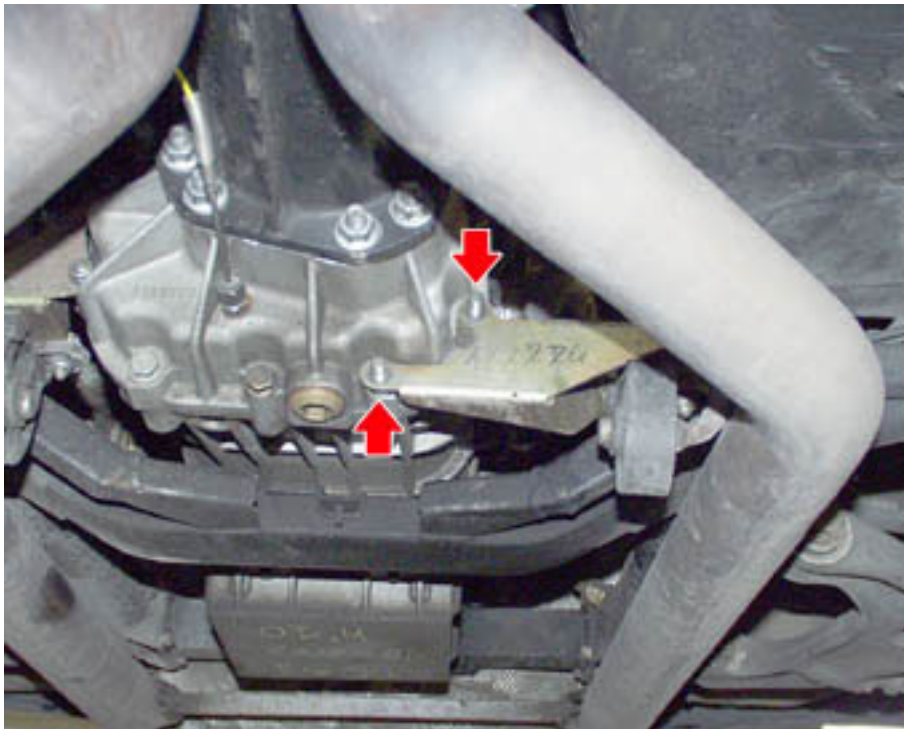

- Working in the wheel compartment, undo the two screws fastening the vibration damper to the car body (Figures 1 and 2).



## ENGINE REMOVING

- Position the engine, without the clutch, onto the support stand **AV2023** , fixing it with the support tool **900026310**.



- Detach the injector connections.



- Take away the engine wiring.



- Remove the engine mounting bracket, using the tool **900027160**.



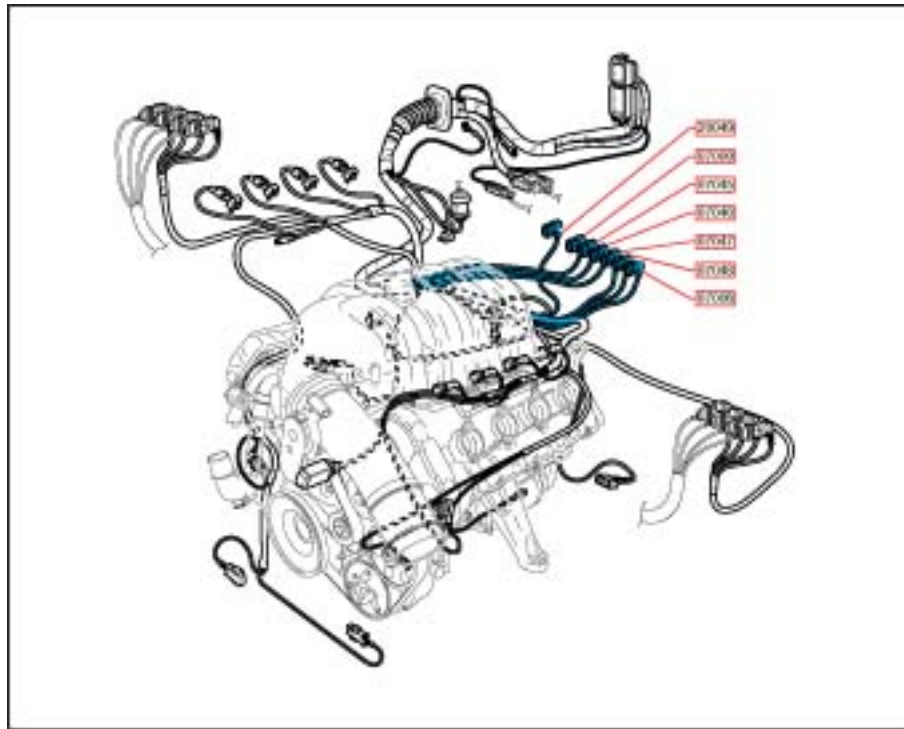

- Remove the exhaust camshaft screw, countering the rotation with a wrench inserted into the special hexagon machined on the shaft.



- Remove the head gaskets.



- Unscrew the RPM sensor.





- Fit the four anti-detonation sensors and tighten them to a torque of **20 Nm**.



- Fit the rpm sensor and tighten it to a torque of **8 Nm**.



- Fit the crankshaft on its mounts.



- After having thoroughly lubricated the components, fit the connecting rod caps.

**N.B.**

- Be sure that the two marks on the connecting rod and the connecting rod big end are on the same side during the assembly procedure.



- It is advisable to apply a small amount of silicone **CAF4** on the ends of the head gaskets, on the timing side.

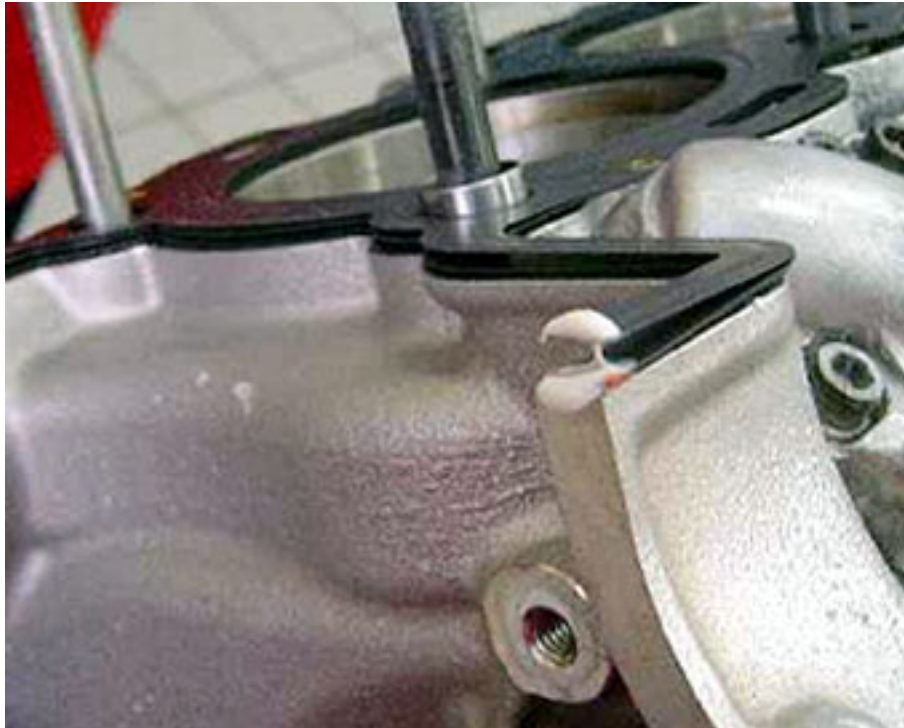

**N.B.** Before fitting the engine head, turn the crankshaft in such a way that all the pistons are positioned below the TDC. To do this, you must rotate the crankshaft until the tab on the crankshaft (timing side) is positioned as shown in the figure.

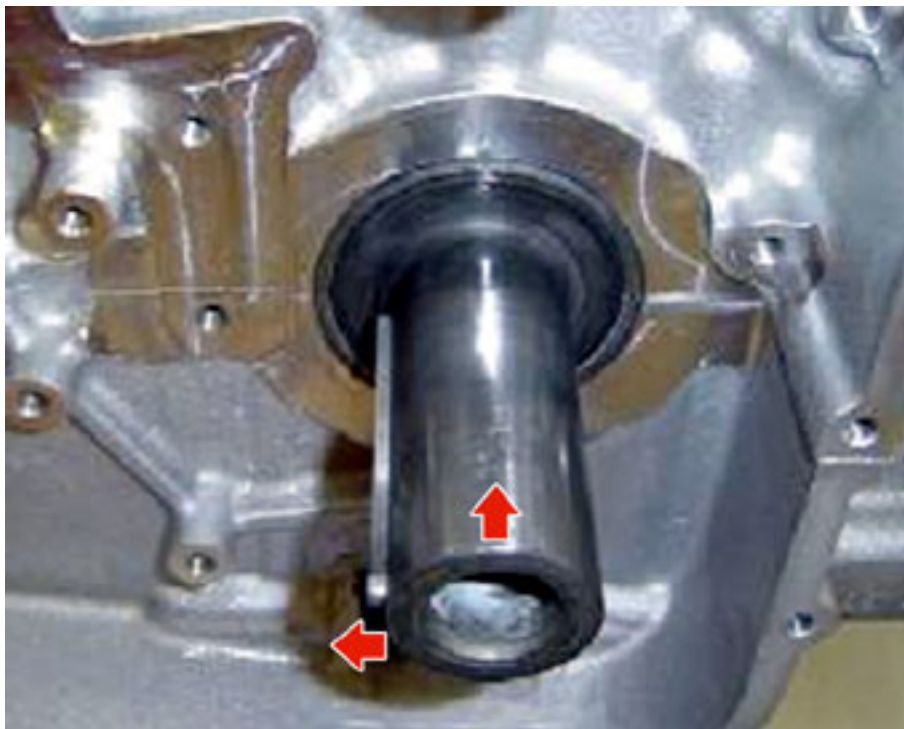

- If the pump assembly shaft bearing has been removed, refit it following the procedure described.
- Position the bearing centring template **900027040**.

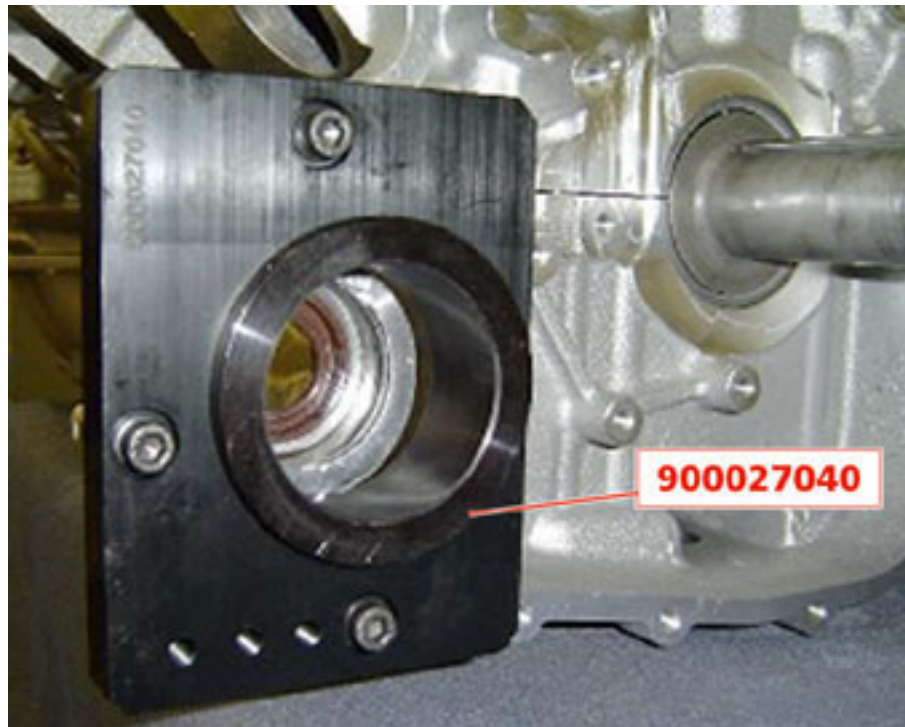

- Place the  $\text{Ø } 25\text{-}47 \times 12$  ball bearing on the fitting punch.



**IMPORTANT:**

The tightening torques for the chain runners are 10 Nm for the 6mm screws and 25 Nm for the 8mm screws.

- Install the mechanical tensioner for the transmission axle.



- Fit the gearwheel for the exhaust camshaft. Position the centring dowel into the first free hole available, after coupling the gearwheel onto the camshaft.



- Check that the pointer of the dial gauge fitted on the holder **CS104488** always indicates the TDC position.



- Lubricate the seats of the cooling circuit grommets.



- Fit tool **900026590** onto the crankshaft, in such a way that the oil seal will not be damaged when the cover is installed.



- Fit the ignition coils (**Figure 1**) and tighten the retaining screws to a torque of **10 Nm** (**Figure 2**).

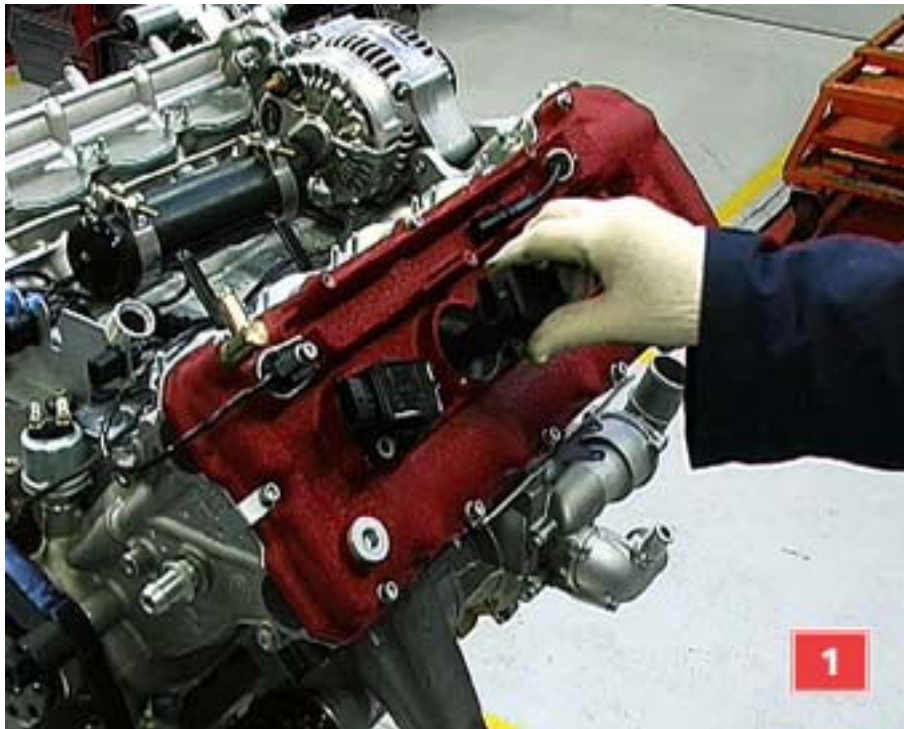

- Connect the ignition coil wiring harness.



- Fit the wiring covers, securing the screws with Loctite 242 to a torque of **8 Nm**.



- The dimensions detected must fall within the indicated values.

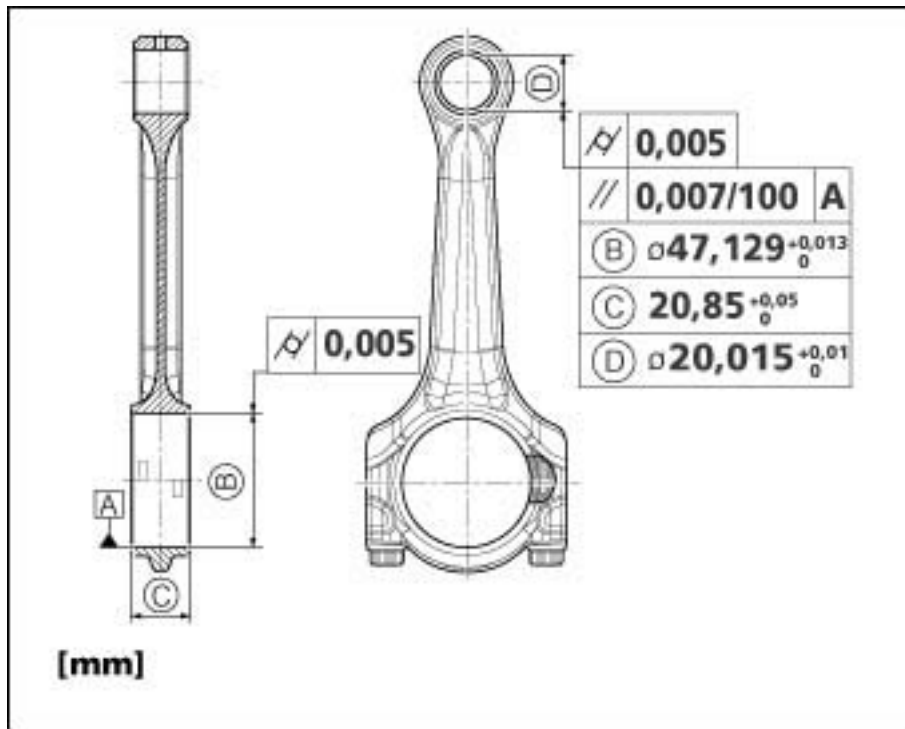

- To measure the diameter of the connecting rod small end, reset the bore meter on the indicated tool (diameter 20 mm).



- The dimensions detected must fall within the indicated values.

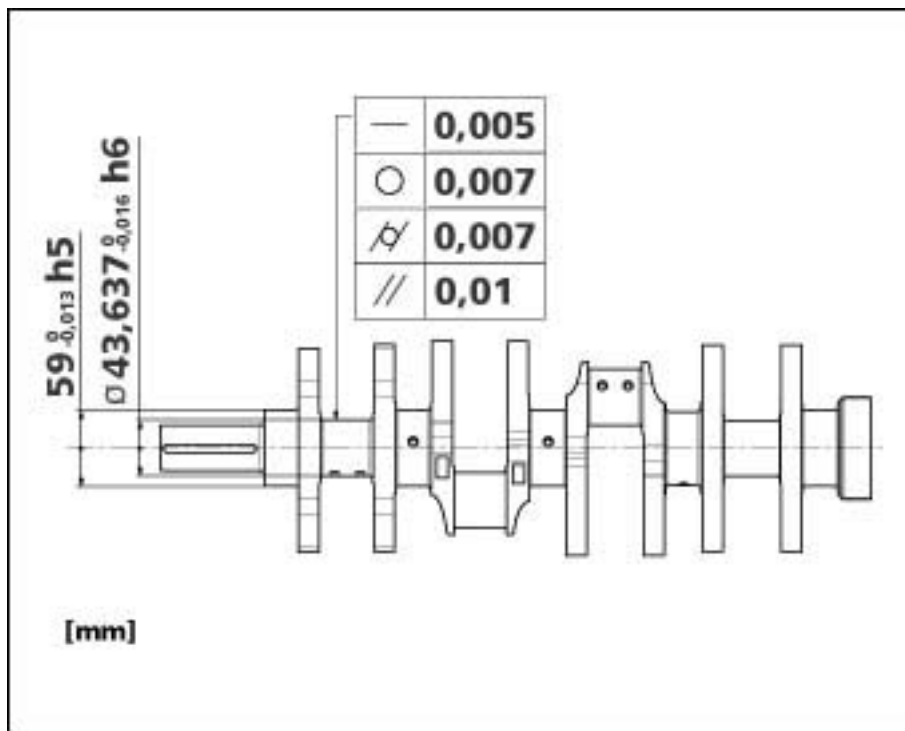

**N.B.**

To check the coaxial factor of the main bearing journals a checking plane is required.

- Arrange the crankshaft on the specified tool AV3135.



- To insert the new guides, it is necessary to heat the head at about **100 °C** for ca. **1 hour** and then cool down the guides in liquid nitrogen.
- To install the new guide **(2)** use tool **AS 102178** with shim **AV 3537**.

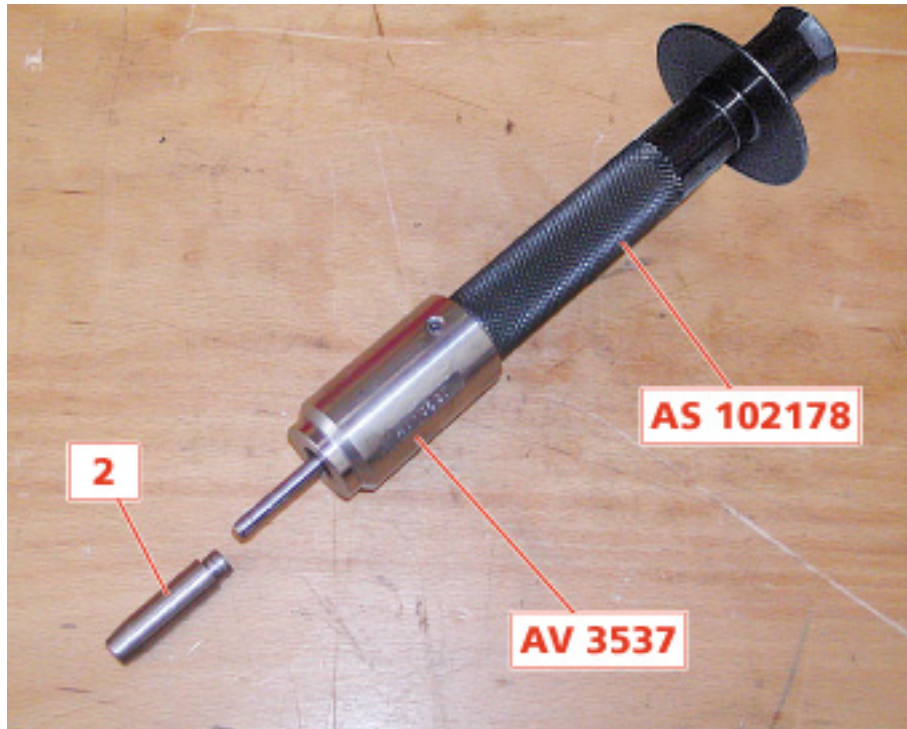

- Lubricate the guide with "SEGO" grease and push it into its seat, until the shim AV 3537 comes flush with the head.

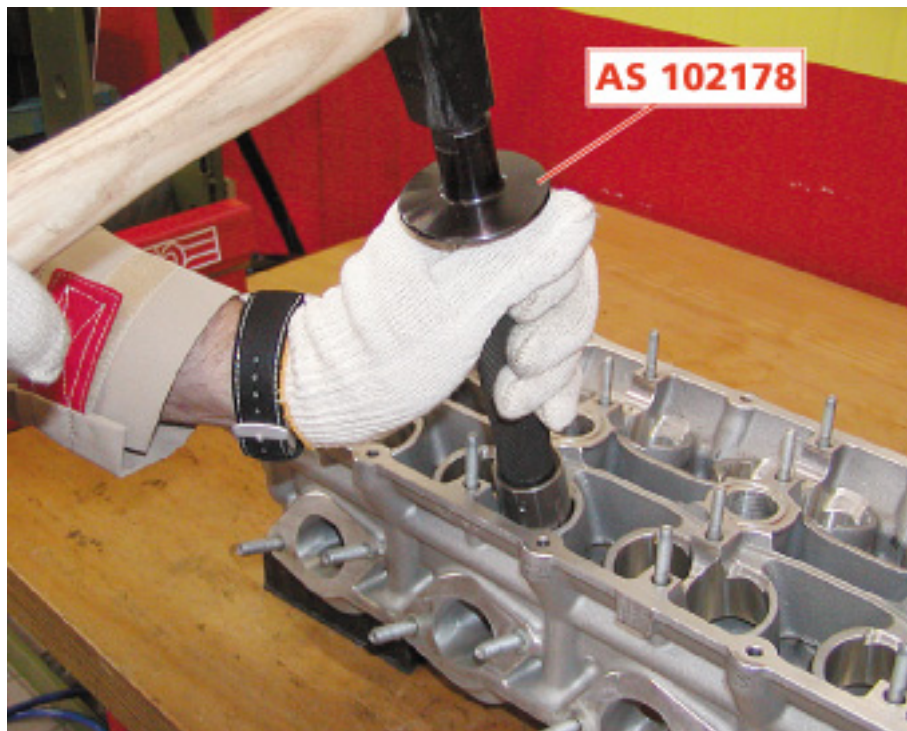

- Fit the rectangular punch (**D**), supplied with the equipment, to plug the intake duct. Fit a round-shaped punch to plug the exhaust duct
- Activate the "Vacutest" and check on the pressure gauge that vacuum ranges between **0,94** and **0,86 bar**. If the value proves to be lower, check once again applying a "Prussian Blue" layer, in order to verify which is the seat to be ground once again.

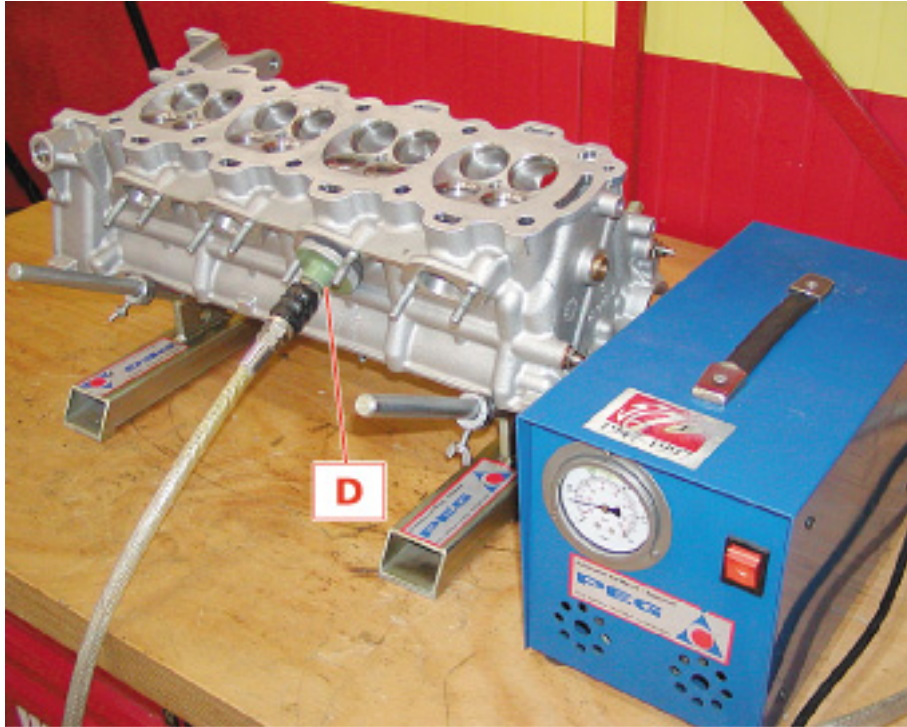

- With the tool, detach the push fittings on the side panel of the luggage compartment and then remove the panel.

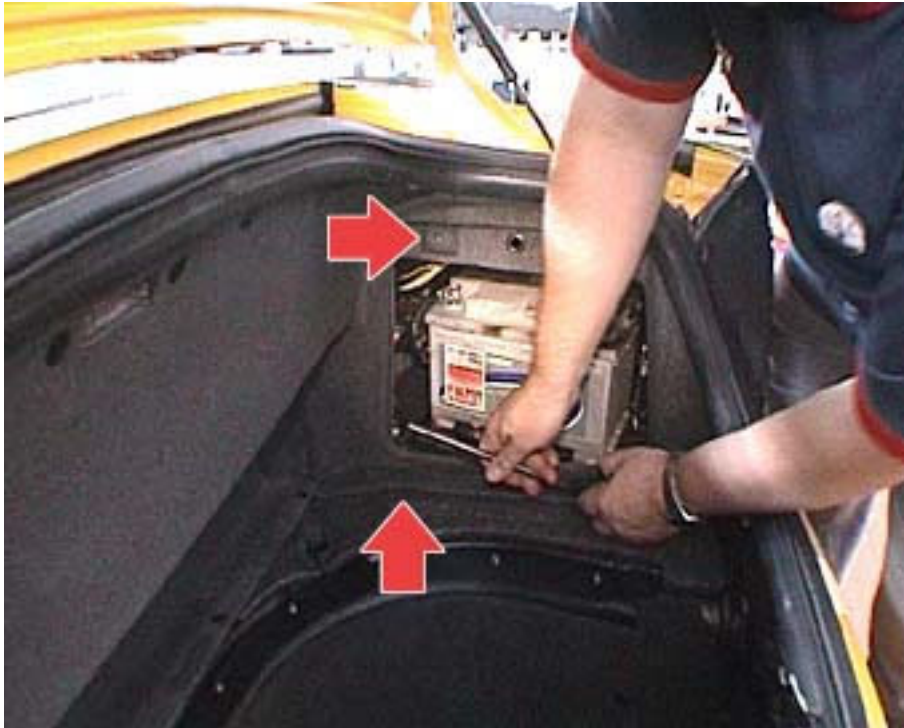

- Unscrew the retaining nut on the battery retaining bracket.

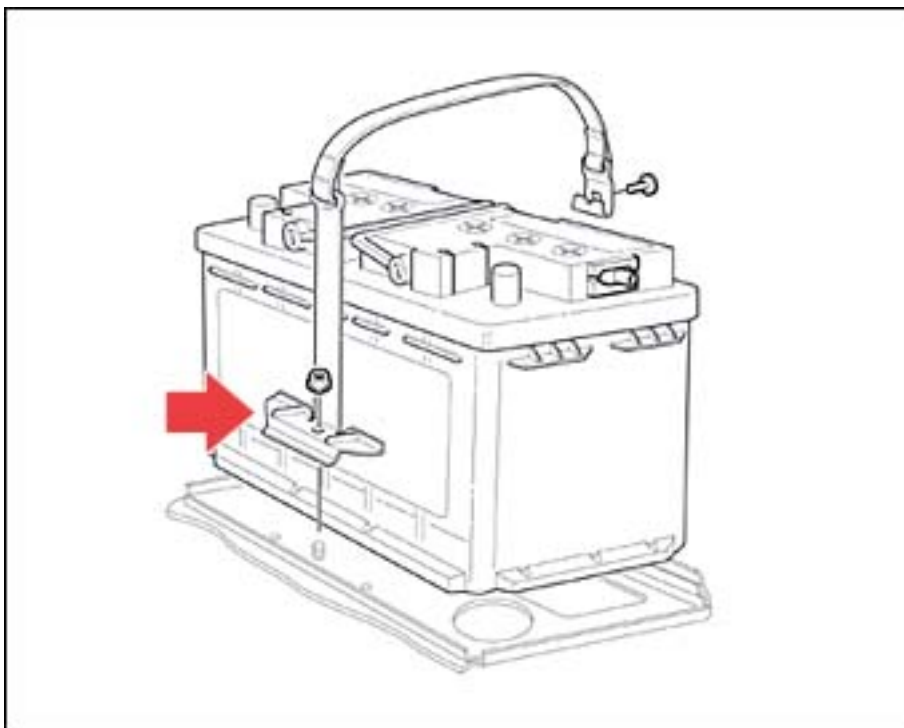

- Remove the air flow meter-oil decanter connection pipe from the retaining clamp.



- Unscrew the two nuts fastening the stiff pipe to the engine.



- Lift the engine to a height sufficient to insert the shield and secure it with the four screws.



- Insert the new gaskets on the stud bolts for the exhaust manifolds.

**N.B.**

**The gaskets have a raised side that should face the exhaust pipes when refitting them.**



- Connect the small pipe to the secondary air valve.



- Attach the lid-open indicator connector.

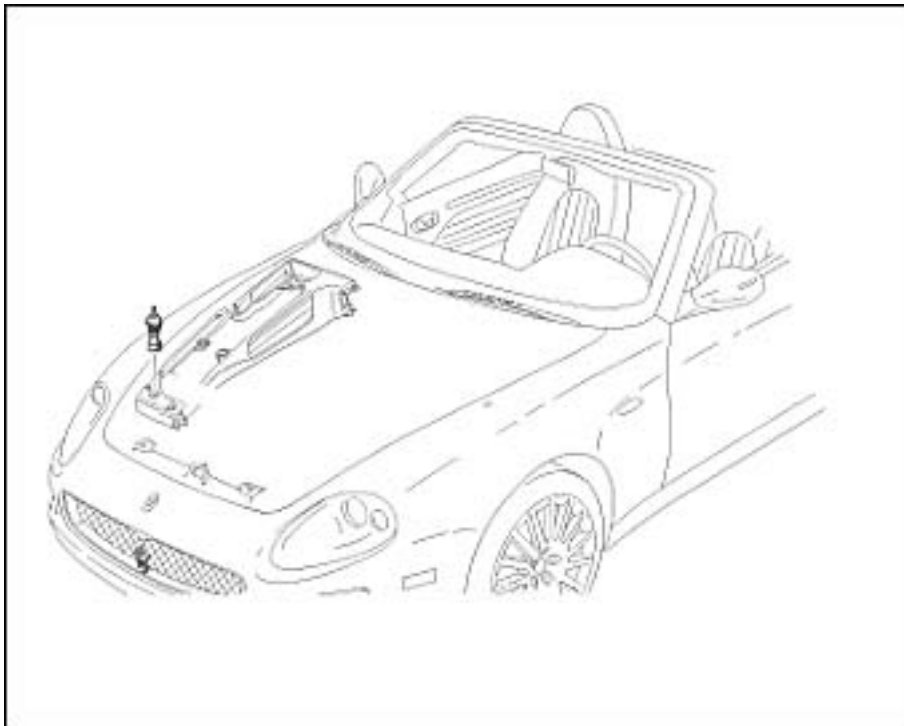

- Position the tank on the hydraulic lift, align it with the housing, lower the hydraulic lift supporting the transmission shaft until the shaft ends its downstroke. Position the hydraulic lift slightly lower than the transmission shaft.
- Exert a slight downwards pressure on the transmission shaft to slide the tank into the housing, taking care not to crush the pipes on the body just above the tank.



*M1380MO-B1243A-A2.jpg*

- Use the hydraulic lift to bring the shaft back into its original position.



*M1380MO-B1233A-A2.jpg*

- Unscrew the two bolts securing the rear glove compartment and remove the front panel by pushing it towards the car's rear side.

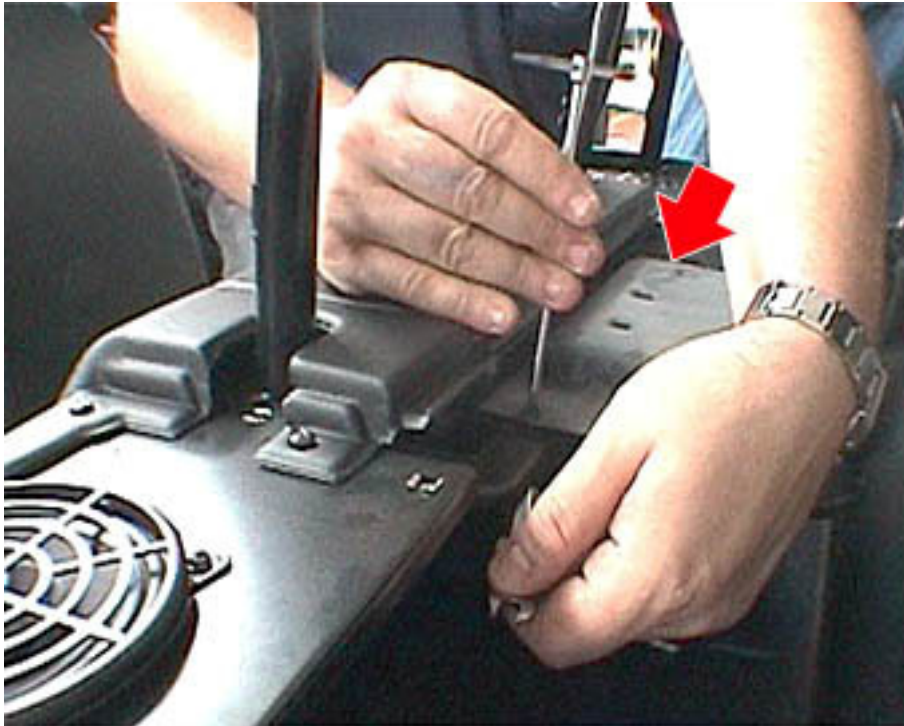

- Detach the two emergency soft top opening/closing cable connectors from the rear glove compartment.

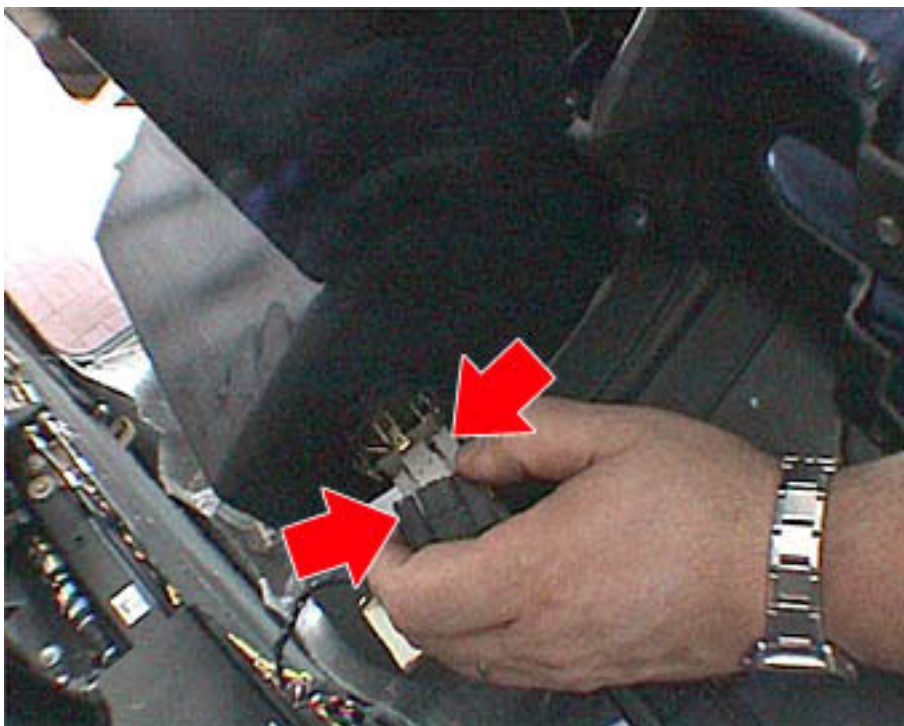

- Connect the pipe linking the roll-over valve and the fluid decanter.



- Position the anti-evaporation system cover and tighten the nine screws.



- Remove the four side victaulic couplings to the vapour separator (**Figures 1 and 2**).

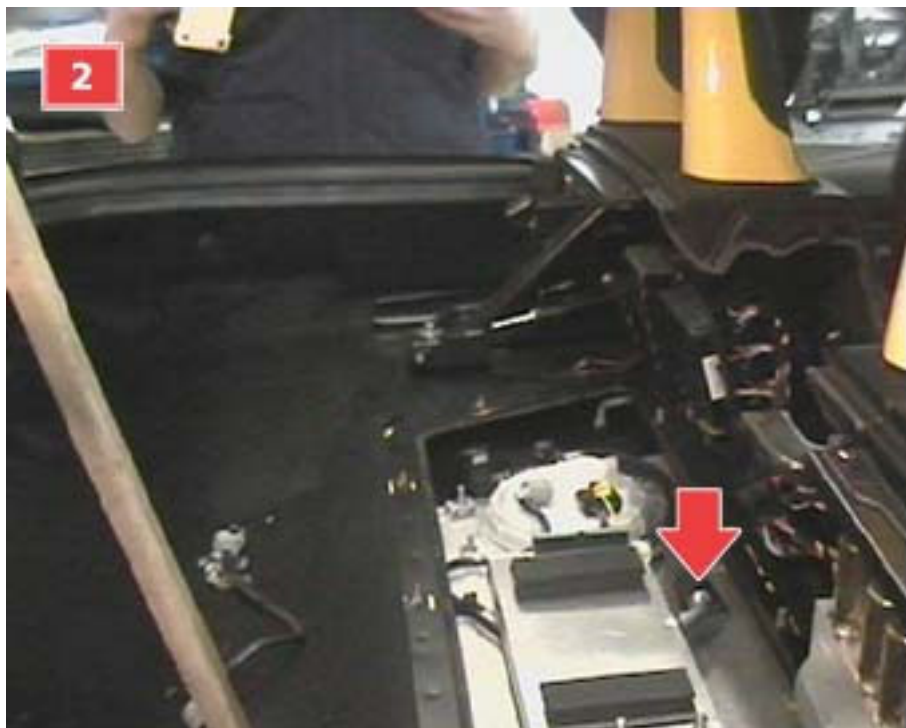
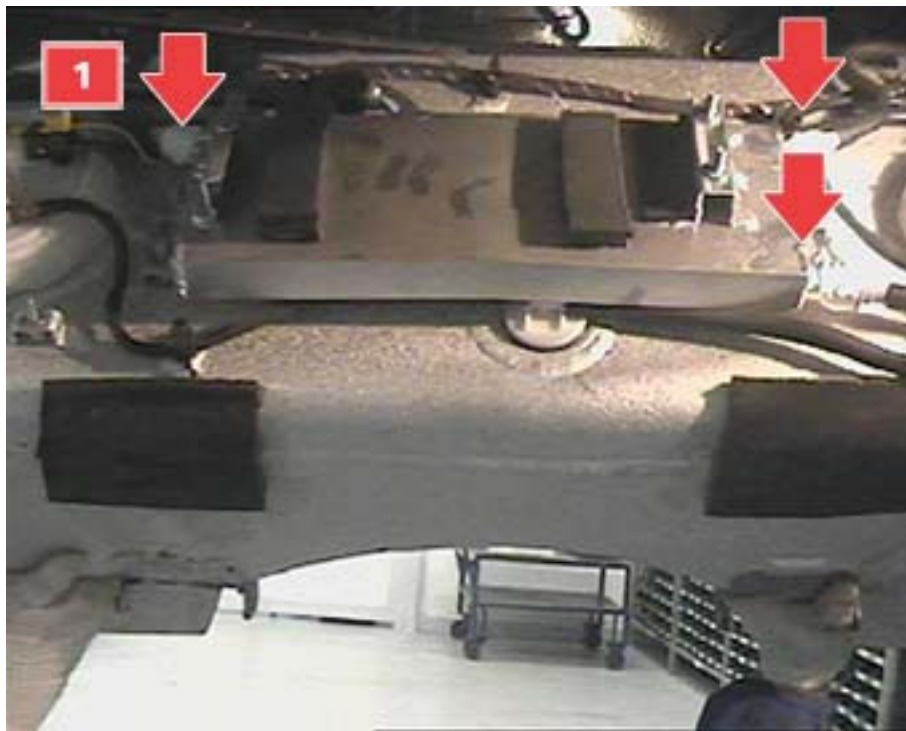

When fitting, follow the procedures described above in reverse order.

## REMOVING-REFITTING THE ELECTRONICALLY-CONTROLLED GEARBOX

- Position the car on a hoist
- Open the engine and luggage compartments
- Disconnect the battery from the switch in the luggage compartment
- Remove the rear wheels

### *Replacing the wheels*

- Remove the spare wheel housing

### *Removing/refitting the spare wheel housing*

- Remove the heat shield



- Remove the central exhaust line

### *Removing/refitting the central exhaust line*

- Remove the handbrake cables and tie-rods

### *Removing/refitting the handbrake cables and tie-rods*

CLICK HERE TO **DOWNLOAD** THE COMPLETE MANUAL

- Thank you very much for reading the preview of the manual.
- You can download the complete manual from: [www.heydownloads.com](http://www.heydownloads.com) by clicking the link below



- Please note: If there is no response to CLICKING the link, please download this PDF first and then click on it.

CLICK HERE TO **DOWNLOAD** THE COMPLETE MANUAL

- Undo the two side fastening screws.

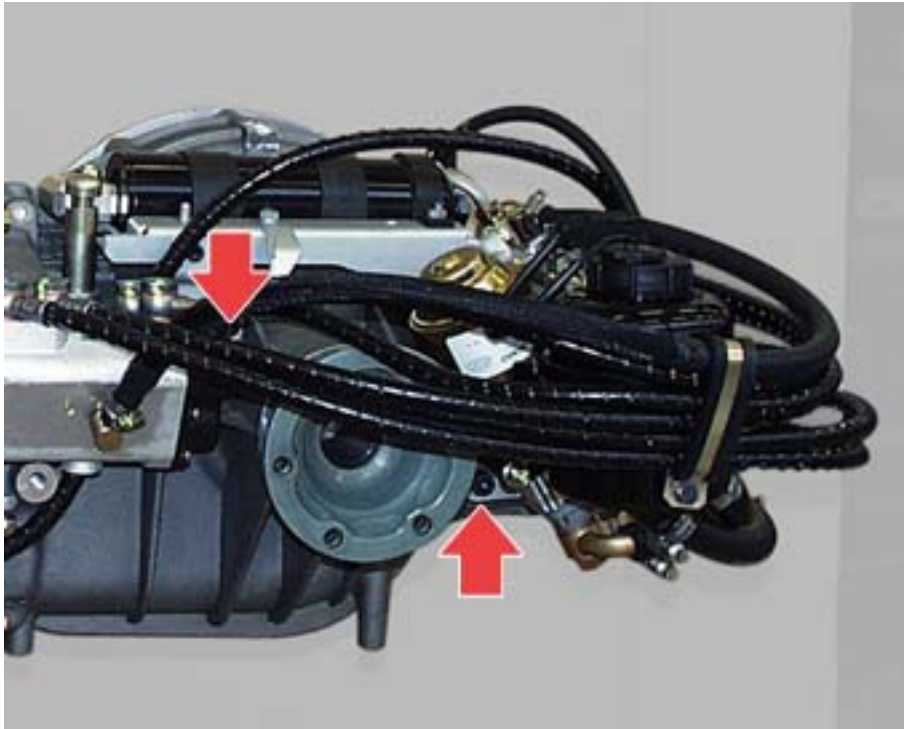

### Fitting

- Position the power unit near the gearbox.



## CLUTCH REMOVAL

### Removing the transmission shaft

- Remove the spare wheel housing.  
*Removing/refitting the spare wheel housing*
- Remove the central exhaust line.  
*Removing/refitting the central exhaust line*
- Remove the handbrake cable.  
*Removing-refitting the handbrake and tie-rods*
- Detach the cooling system oil delivery and return hoses from the gearbox by unscrewing their two screws.

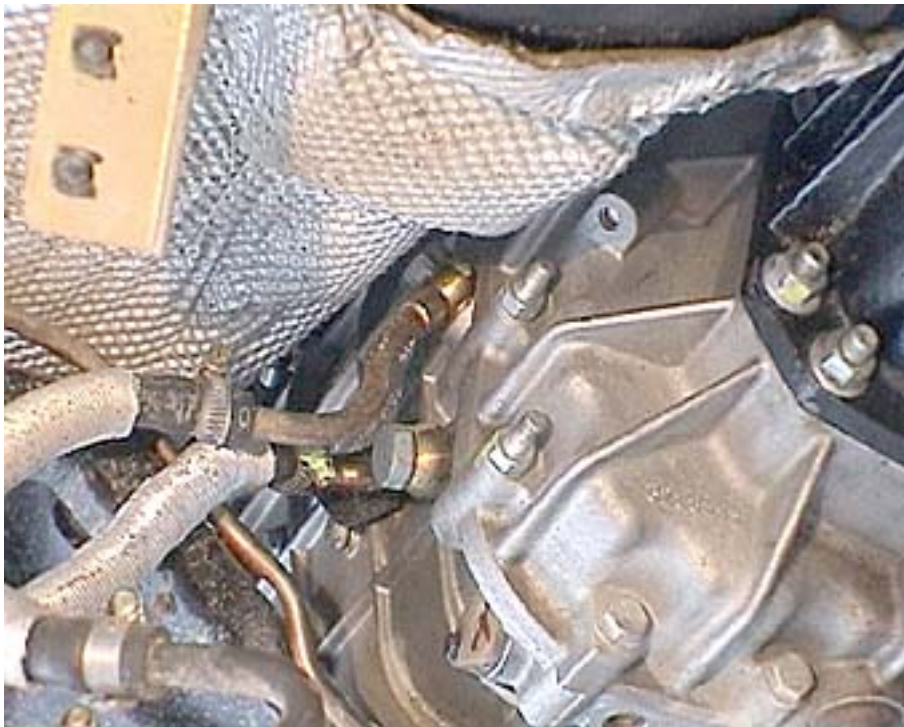

- Lower the second hydraulic lift and tilt the transmission shaft sufficiently to allow its removal from the gearbox unit.



- Unscrew seven of the nuts securing the transmission shaft to the clutch housing, leaving one nut screwed on so as to avoid the shaft coming off unexpectedly.

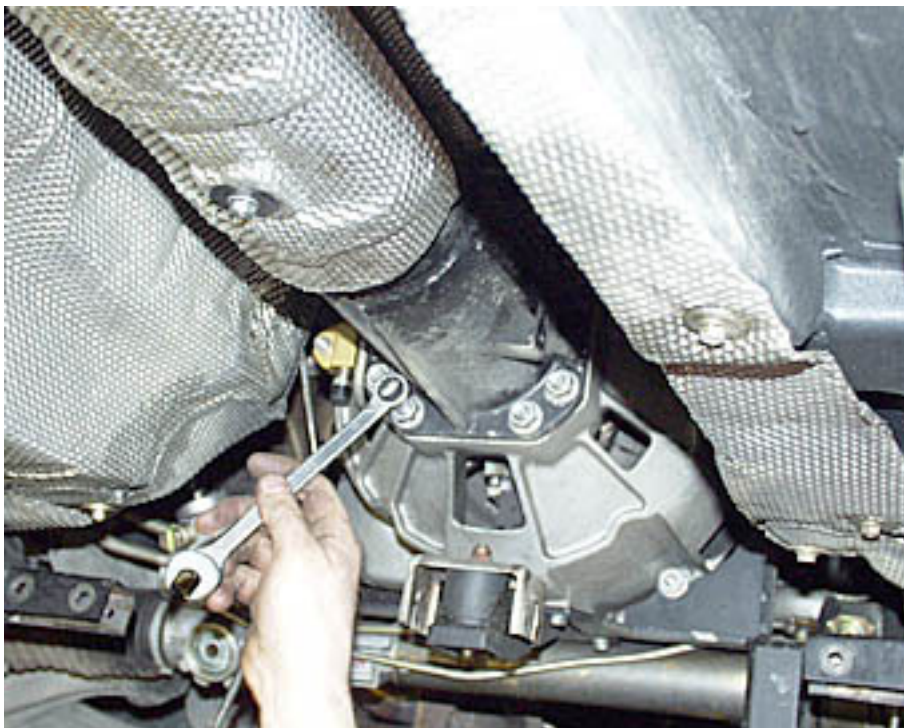

- Tighten the nine screws securing the clutch to a torque of **18Nm**, in a crosswise sequence.

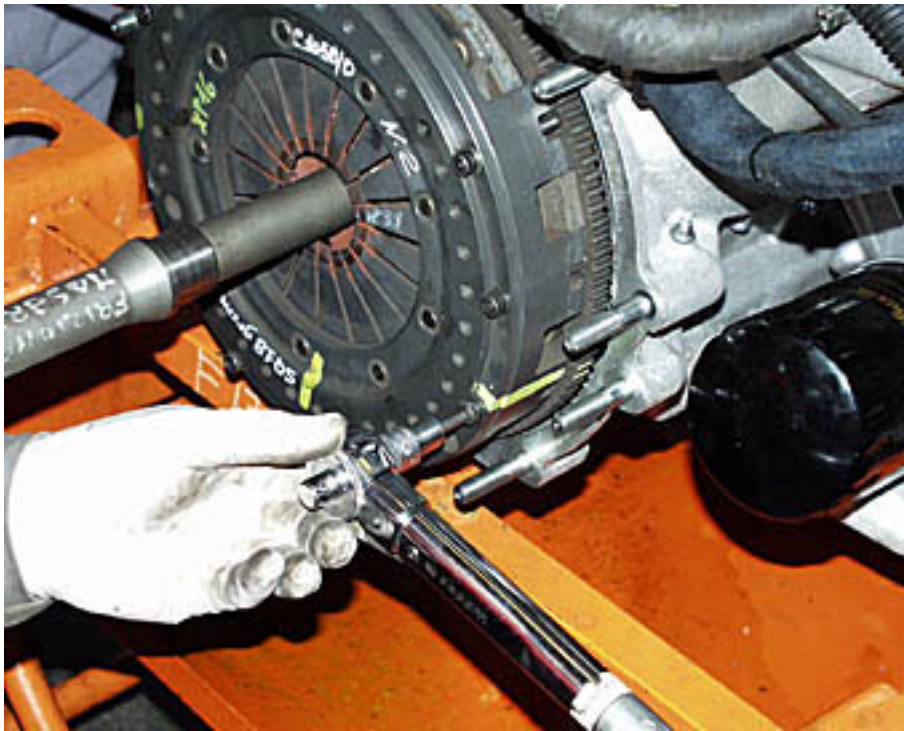

- Apply waterproof grease onto the grooved profile of the thrust bearing and the two clutch housing grub screws.



- Screw the four Lambda sensors and the two thermocouples into their seats.

**N.B.**

**Follow the markings on the Lambda sensors made during removal.**

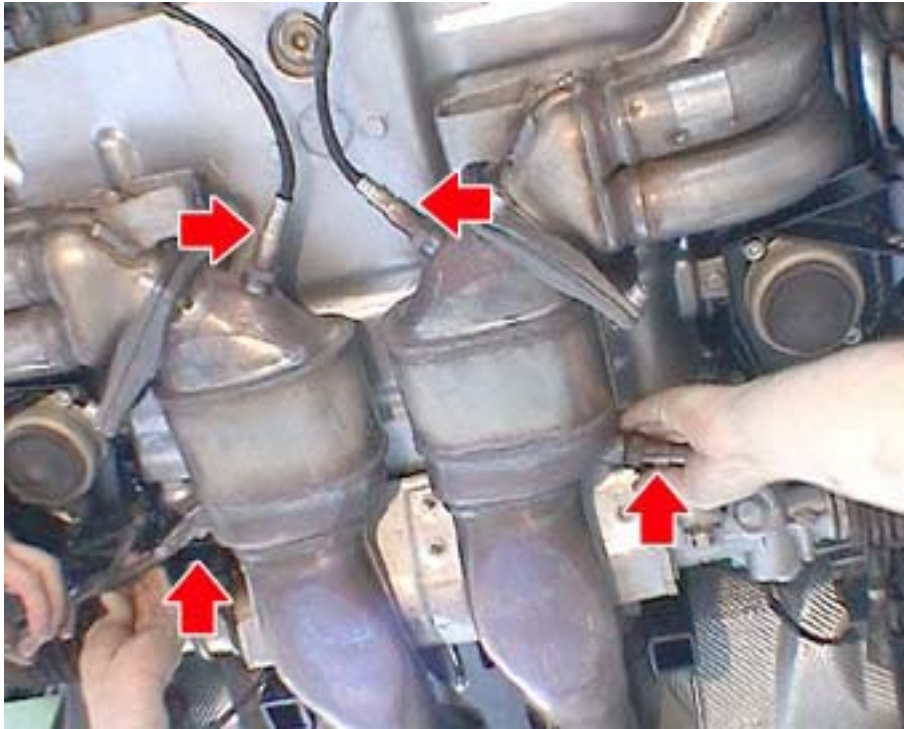

- Screw the two thermocouples into their seats.



- Secure the starter motor by tightening three screws which have to be shorter than those fastening the housing unit.

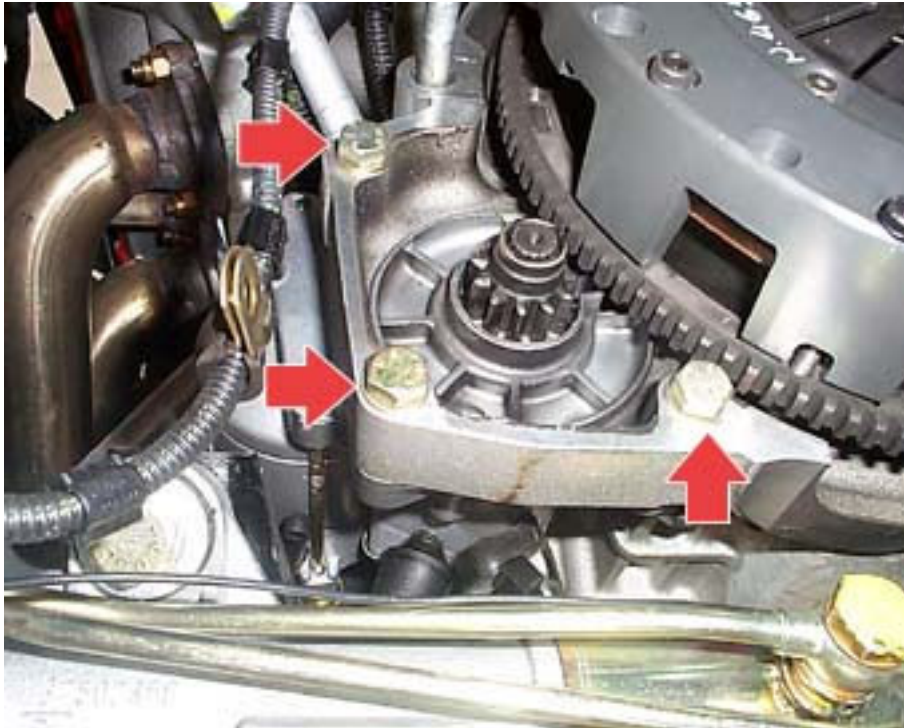

- Connect the earth wire to the crankcase stud bolt.



- Attach the connector for the clutch position sensor.

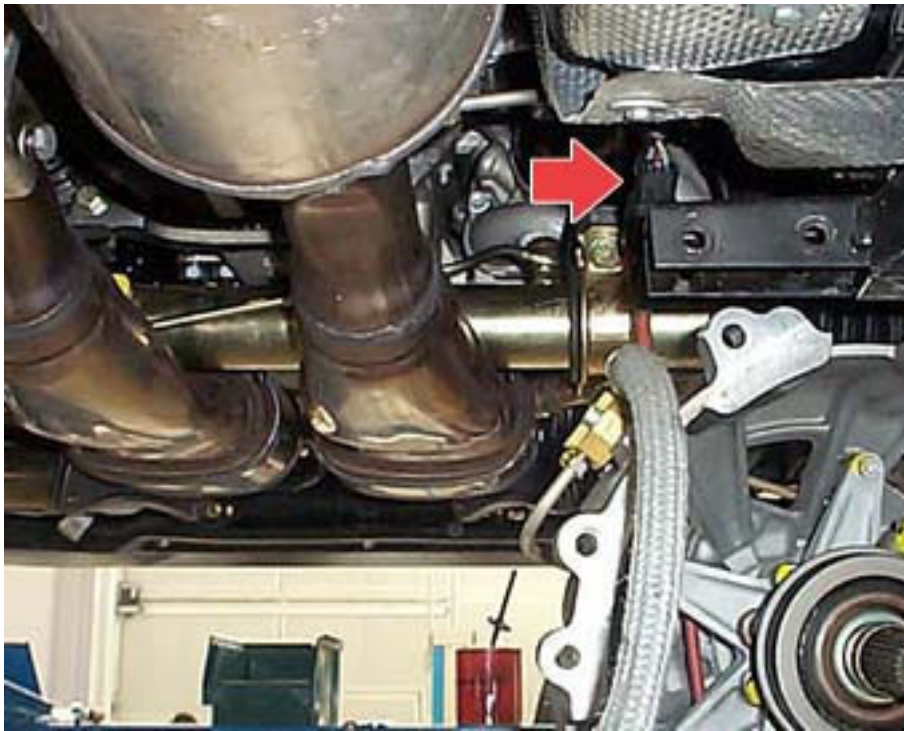

- Secure the starter motor by tightening three screws which have to be shorter than those fastening the housing unit.

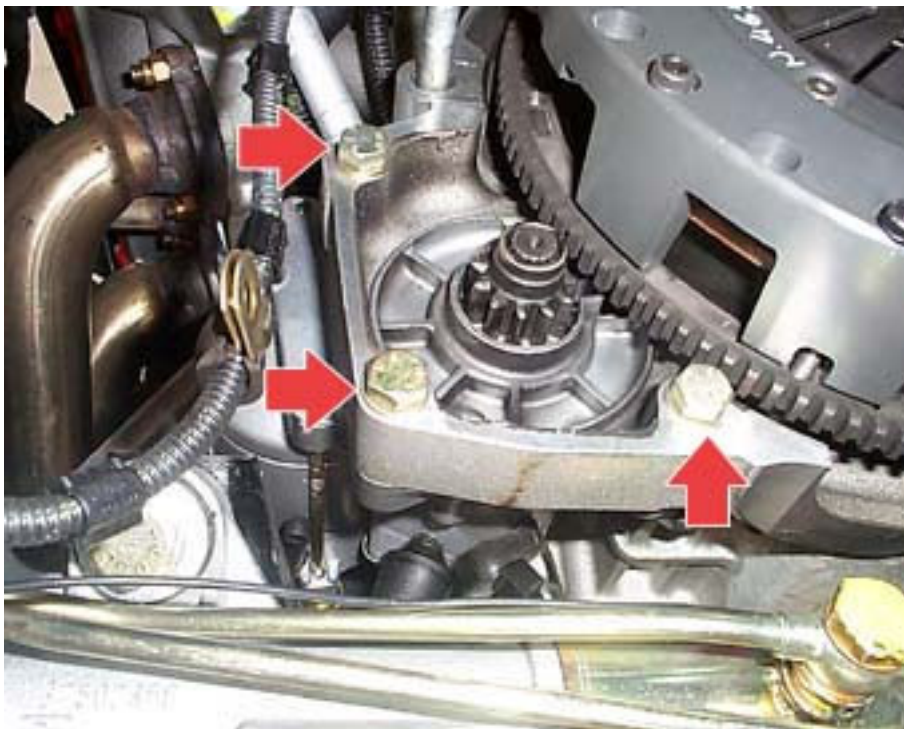

- Remove the seeger ring fastening the clutch pump stem from the pedal.

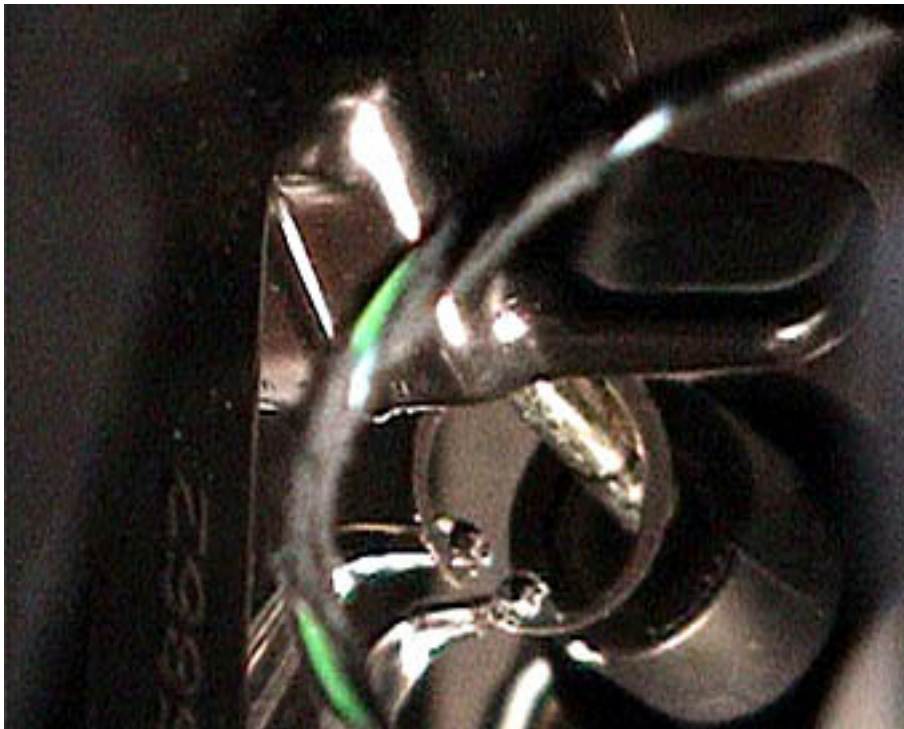

- Slide the clutch pedal from the pin, taking care to keep the two drive half-bushings.

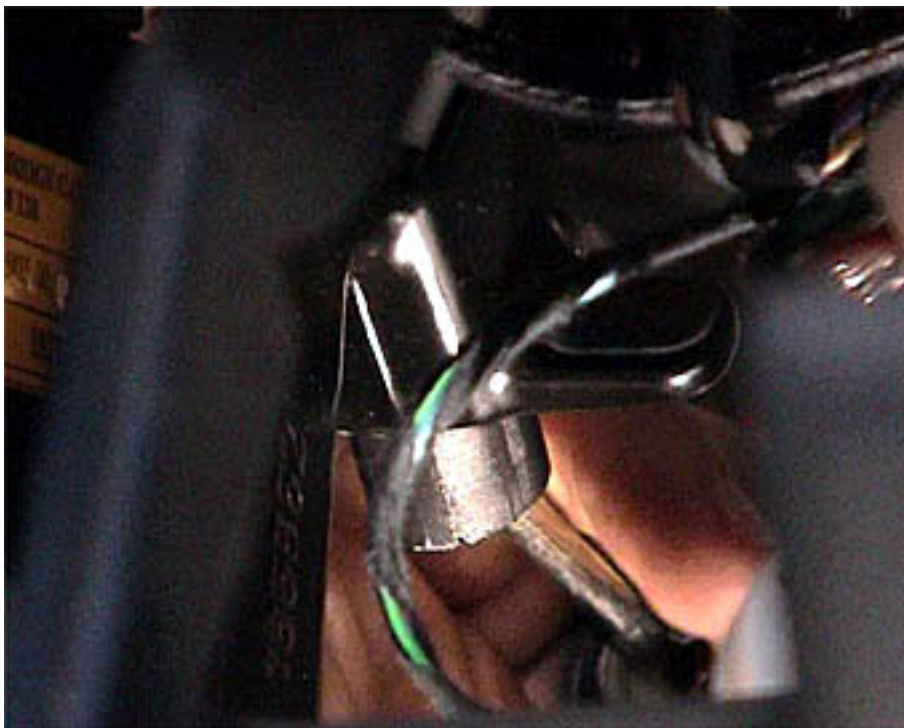

**For refitting, follow the above procedures in reverse order**

- Working from the passenger compartment, tighten the two clutch pump fastening screws to a torque of **20 Nm** and apply sealant **MULTI PURPOSE SILICONE SEALANT**.

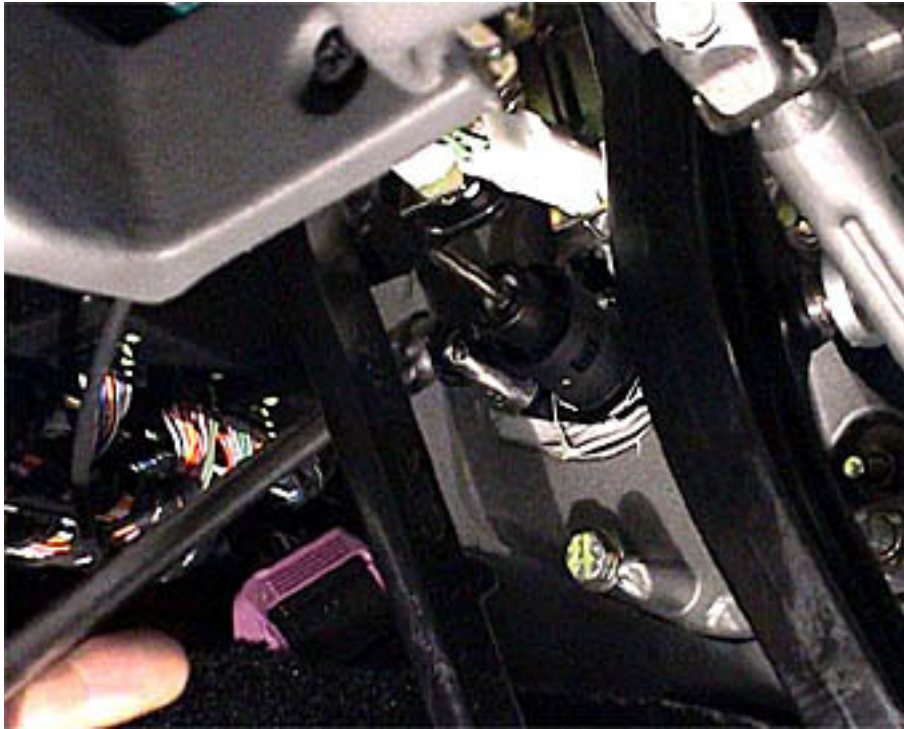

**N.B.**

**On completion of the remounting operation, top up the brake fluid in the tank.**

- Undo the stud bolts **(4)**.
- Extract the thrust bearing **(5)** taking care not to damage the inner grommets.
- Remove the springs **(6)** and the spacers **(7)**.

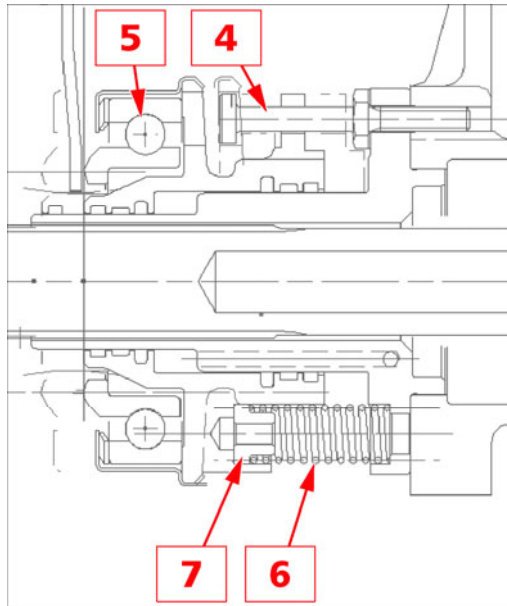

- Connect the left and right half shafts to the differential output flanges, tightening the six screws to **80 Nm**.

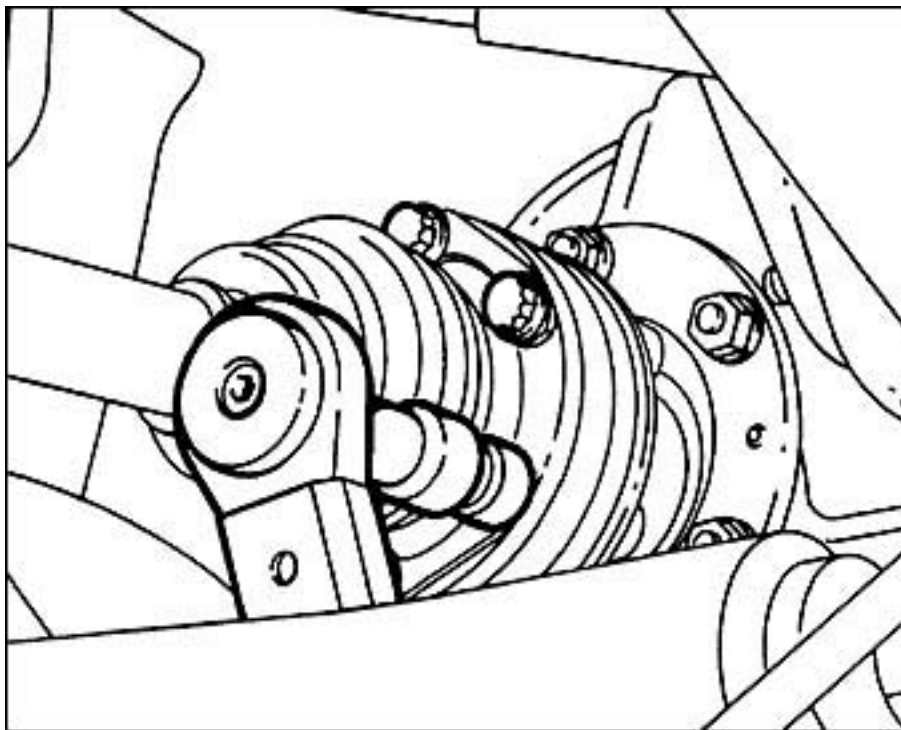

- Clean and degrease the contact surfaces on the cover and differential housing and outline the holes uniformly and evenly with LOCTITE 510.  
Fit the differential housing cover matching the lubrication opening (1) found on the cover with the differential housing retaining washer (2).

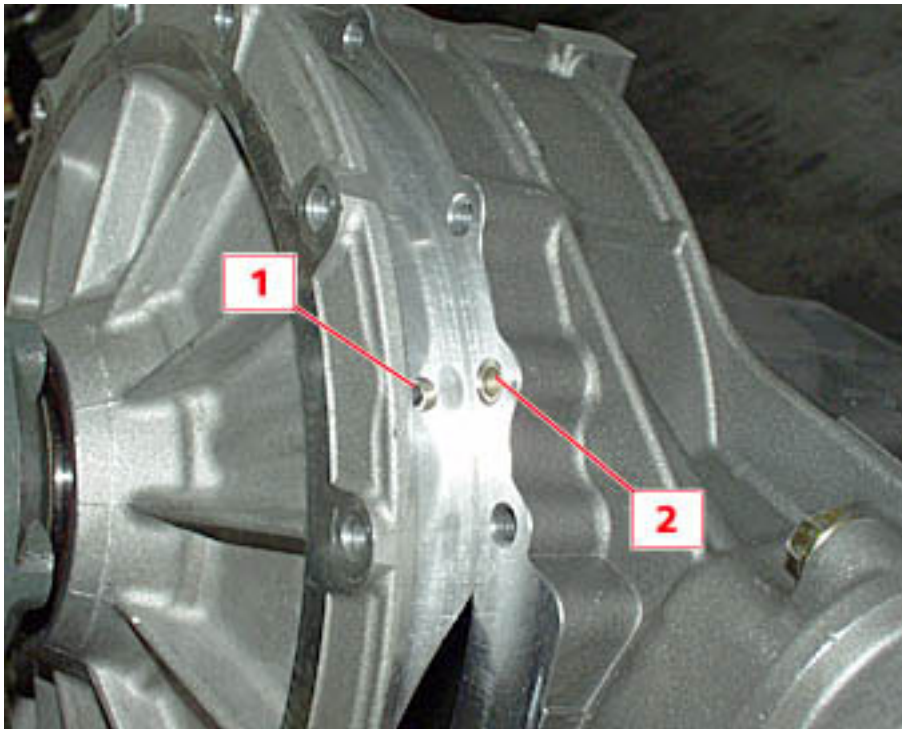

- Position the two cable-guide brackets (3) and tighten the eleven fastening screws on the differential housing cover to a torque of 30 Nm, proceeding crosswise.

**N.B.**

The front fastening screw differs in the length of the thread stem. check the figure for proper fitting.



### Removal of shaft-rods unit with forks

**N.B.**

Before working on the internal parts of the gearbox, it is advisable to check the housing for any cracks or deformation, or the presence of lubricant leakage from couplings or from the closure flanges.

#### **IMPORTANT**

If replacement of the gearbox housing is necessary, the thickness of the crown wheel and pinion spacers should be calculated on the basis of the new dimensions.

- Unscrew the two fastening screws for the lubrication nozzle from the differential compartment.

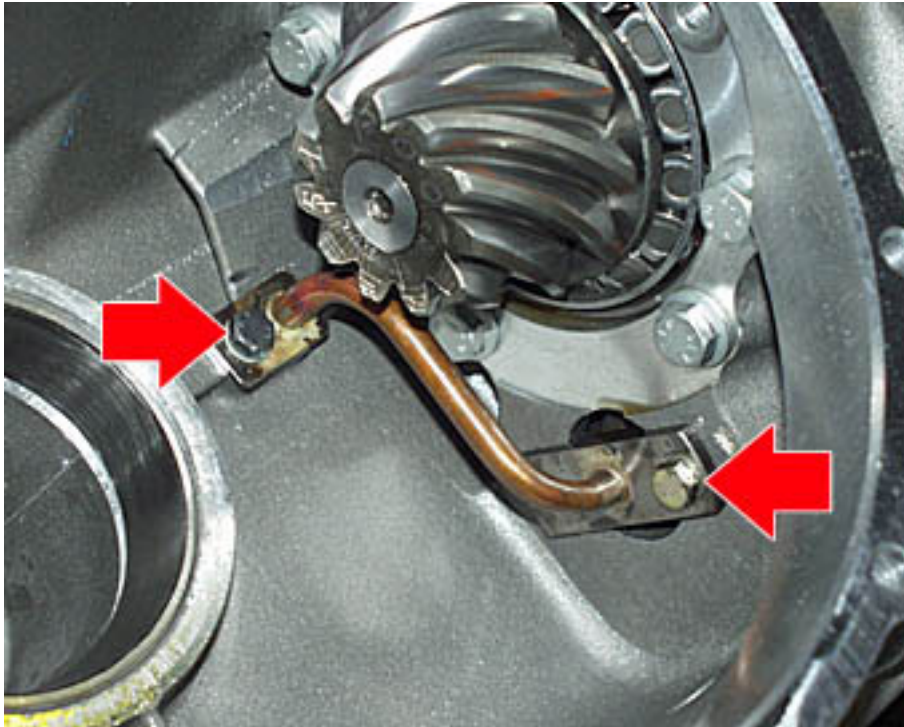

- Slide the driving **Reverse** gearing and respective O-ring off the lay shaft.



- Unscrew the thirteen screws securing the gearbox housing to the differential housing.



## Main shaft disassembly

- Lock the base (a) of the tool **900026440** in a vice and insert the main shaft from the front cover side.



- Remove the ring nut and the check nut - differential housing side - from the main shaft using a specific wrench **900026880**.

### **IMPORTANT**

**All ring nuts that are removed must be replaced.**



- Install the lay shaft on a support cylinder (**1**), resting the **5th** speed gearing on the support flange **900026820**. Press the shaft to release and extract the shouldering fifth wheel and the double **5th - 6th** speed gearing.



- With the support flange resting on the **3rd** speed gearing, press the shaft to release and extract the double **3rd - 4th** speed gearing.



- Insert the new ball bushing on the differential housing using the punch **95973267**.



- Lock the control rod bushing on the differential housing with two washers and fastening screws.

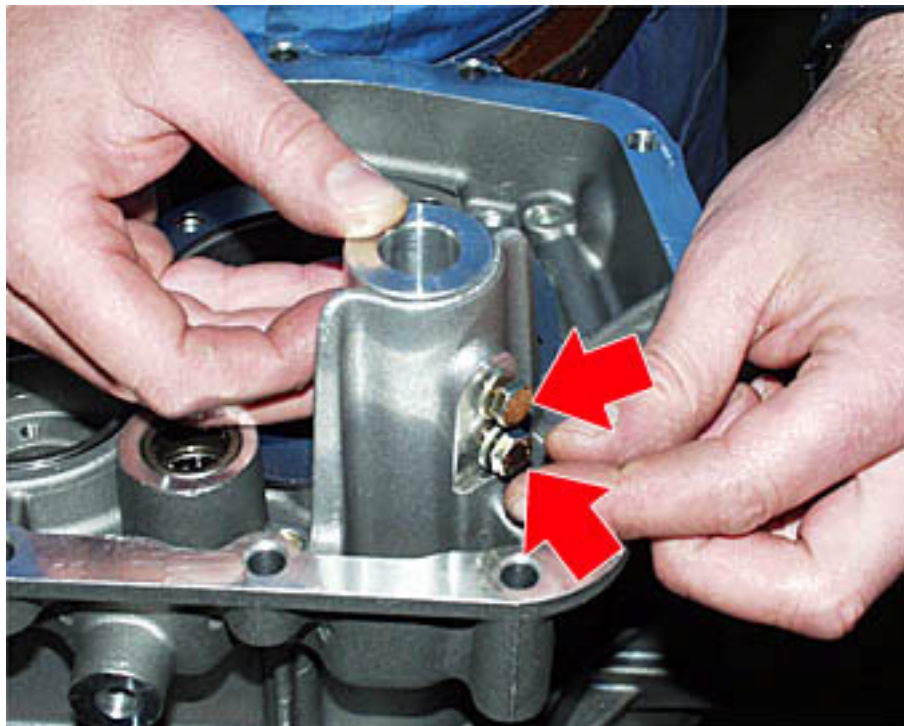

- Fit the **3rd - 4th** speed synchronizer rings onto the **4th** speed gearing coupling element, carefully checking the positioning of the driving teeth on the internal ring with respect to the external ring. Then put the set formed on the main shaft after having first inserted the roller cage.



- Insert the support washer on the main shaft with the slotted side facing the gearing.



- Insert the complete **1st - 2nd** speed synchronizer on the lay shaft and bring it flush with the punch **95973262**.

**N.B.**

After inserting the synchronizer, ensure that the 2nd speed gearing moves freely.



- Insert the **1st** speed gearing bushing on the lay shaft with the punch **95973263**.



- Put the roller bearing on the lay shaft using the tubular punch **95973262**.



- Insert the Seeger ring on the lay shaft.



- Insert the Seeger ring on the lay shaft.



- Put the elastic pins on the **Reverse** gear fork using a pin-driver, as well as the tool **900026430** to help center them.



- Fit the Seeger ring on the differential housing cover.



- Check the condition of the O-ring and fit it on the differential housing cover.

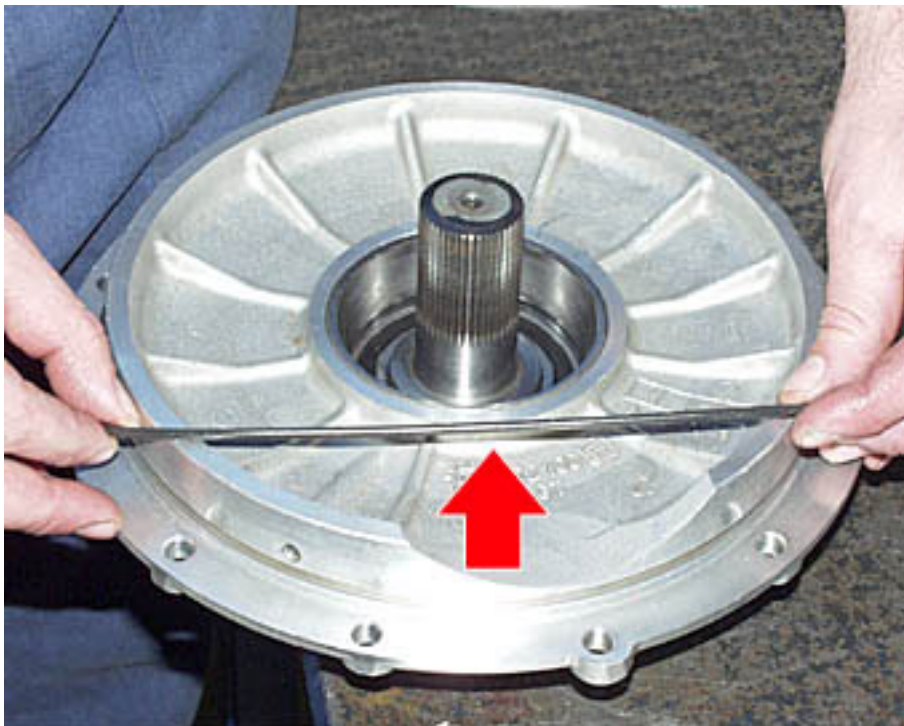

- The deviation **t** from the theoretical distance of **45,10 mm** is marked on the differential crown wheel.



- Thus the actual distance **G** between the crown rear surface and pinion axis is:

$$\mathbf{G = 45,10mm + t}$$

- Working from the differential compartment, bring the unit flush using the nut (**b**) supplied with tool **900026430** and a socket wrench.

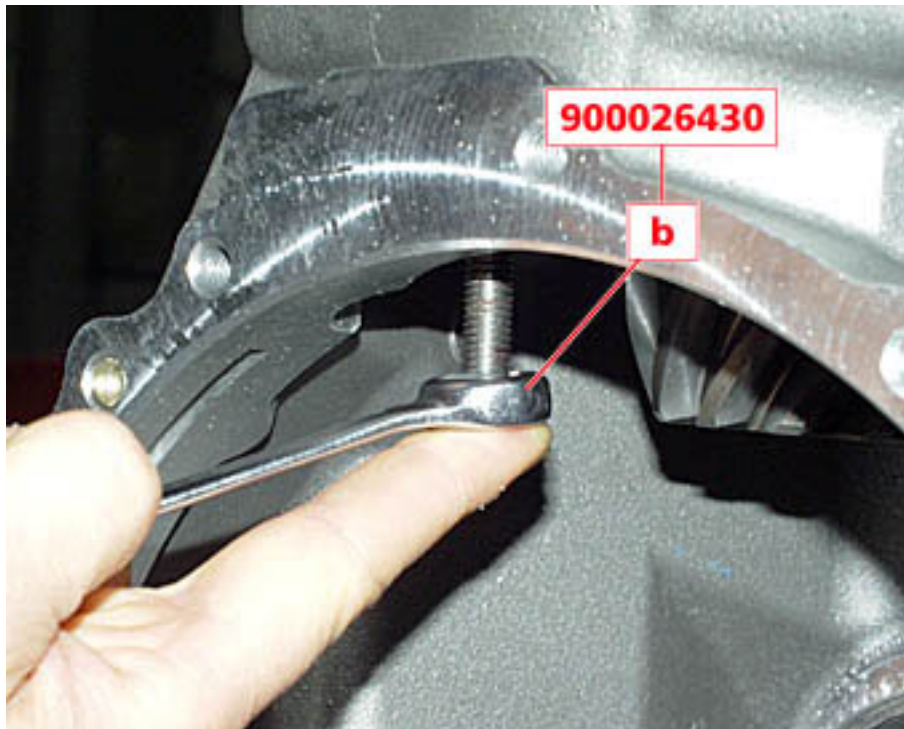

- Remove the centering tools and fix the case in its seat using the specific screws to the torque of **30 Nm**.



- Verify that the values taken are correct by checking the flatness of the bearing inner ring.



- Place the lay shaft equipped with taper roller bearing on the checking plane.



- Considering the deviation marked on the pinion head (**Figure 1**), calculate the distance **P1** between the taper roller bearing surface plane and the differential axle (**Figure 2**).

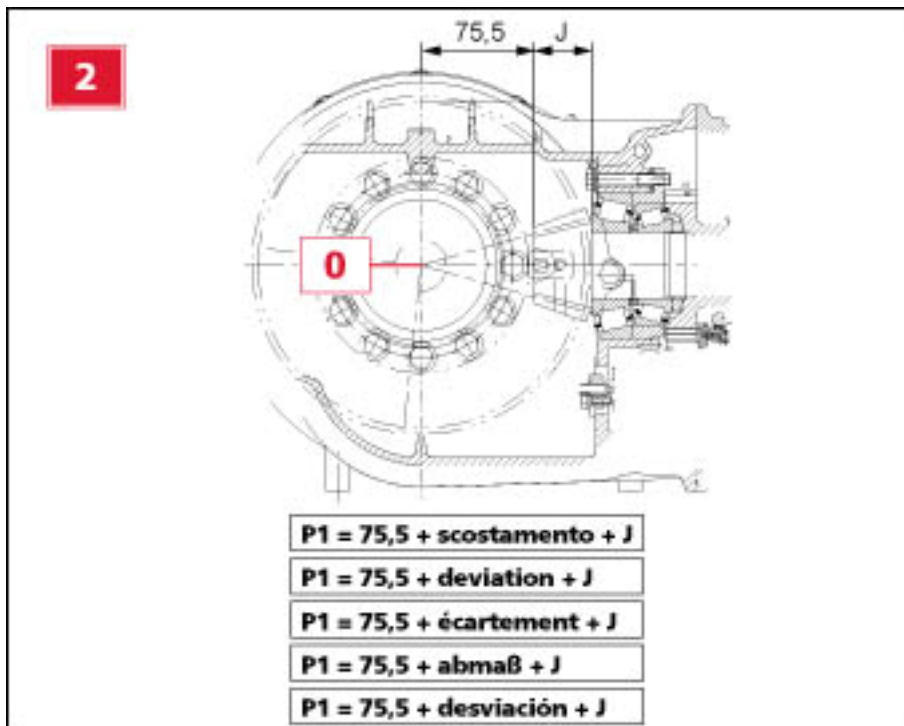

- Insert the pinion positioning spacer under the bearing case and rest it on the checking plane base.
- Measure the distance between the spacer surface (**Figure 1**) and the synchronizer hub (**Figure 2**), the value must be (**Figure 3**):



## Adjusting the gearshift wire

- Disconnect the cable from bracket **(A)** and from the ball joint of rocker **(B)**.
- Connect the head of the cable to the bracket.
- Open the linking block **(C)** and connect the plastic **(D)** end to the ball joint of the rocker.
- Let the internal spring compensate the freeplay of the cable then close the linking block.

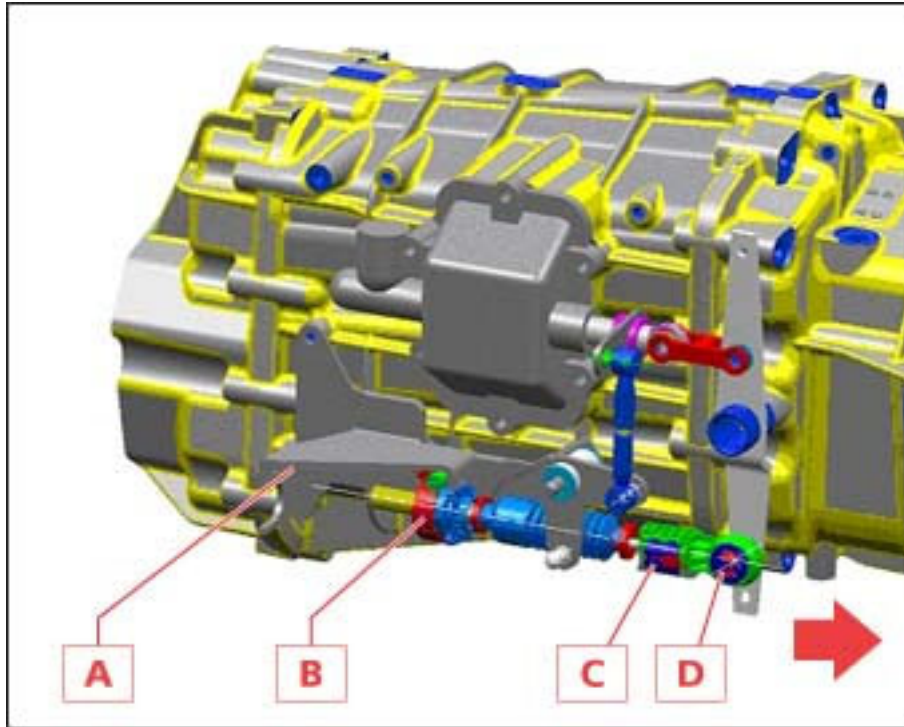

- Undo the rear fastening screw of the gearbox lever housing.

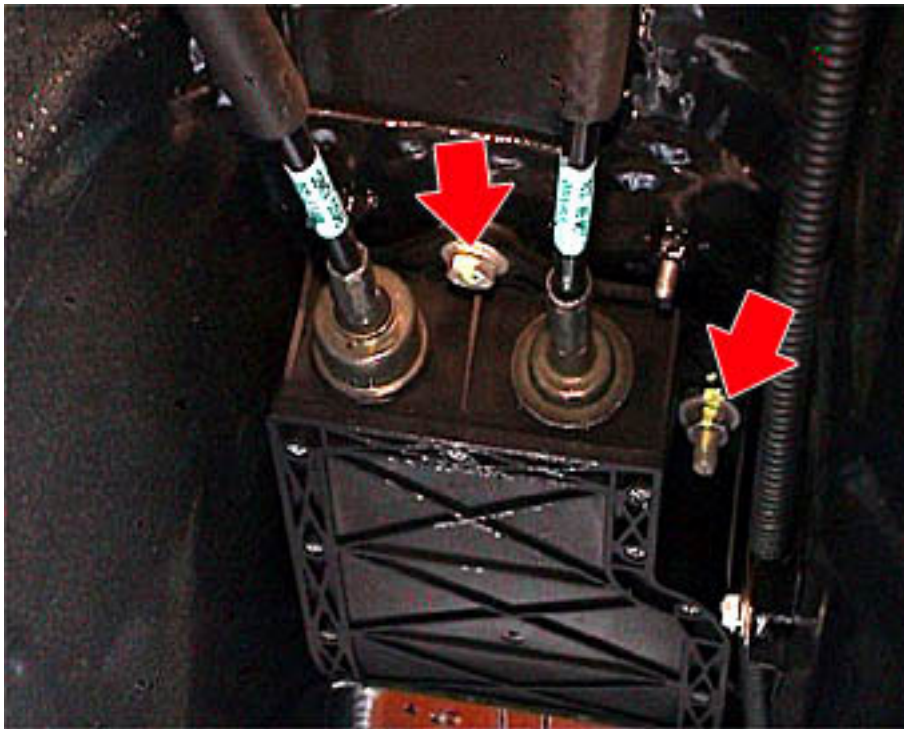

- Remove the gearbox lever housing from the seating.



**Figure no. 9**

- DASHBOARD WIRING EARTH, A.C. UNIT CABLE BUNDLE AND POWER WINDOW KEYBOARD (15 Nm).
- Position: Passenger compartment, tunnel RH side.



**Figure no. 10**

- EARTH FOR DASHBOARD WIRING, A.C. SYSTEM AND INJECTION (15 Nm).
- Position: Passenger compartment, RH side on fire protection shield.

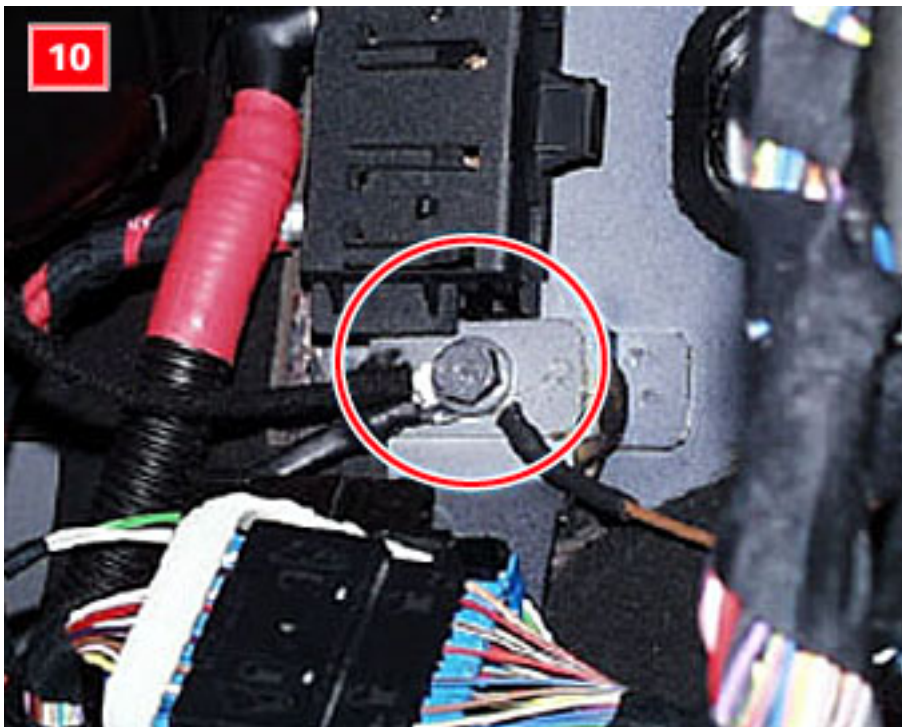

- Detach the fastening buttons on the left-hand side panel of the luggage compartment and remove the panel.



- Disconnect the two connectors on the alarm system ECU and extract it by removing the two fastening nuts.

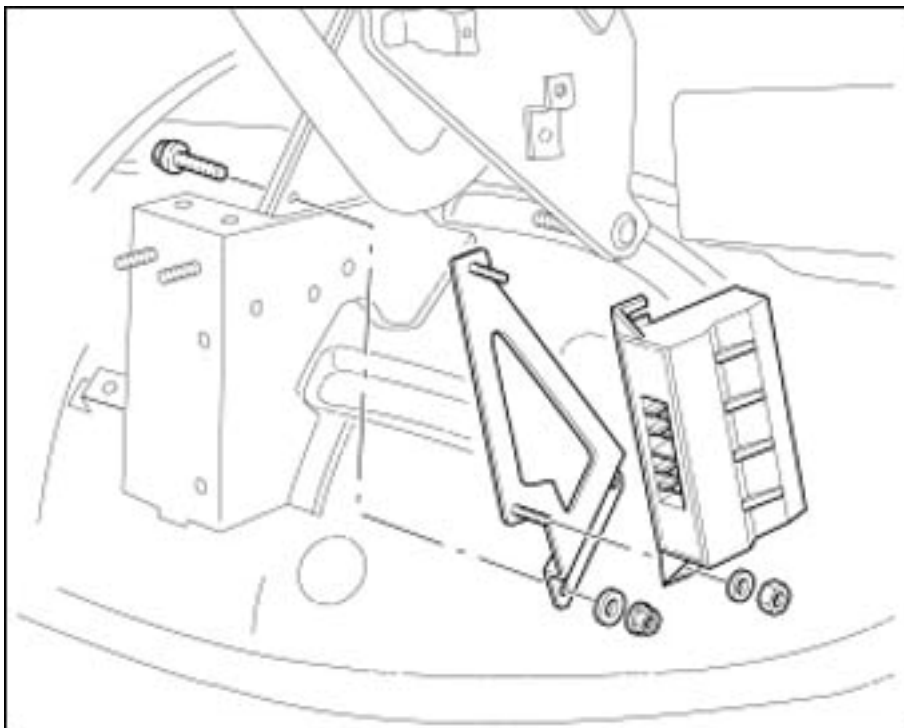

- Remove the armrest unit from its seat following the direction indicated by the arrow

**N.B.:** Take care when carrying out the operation not to damage the dashboard trim panel or any of the other nearby parts



# FUEL SUPPLY DISTRIBUTION

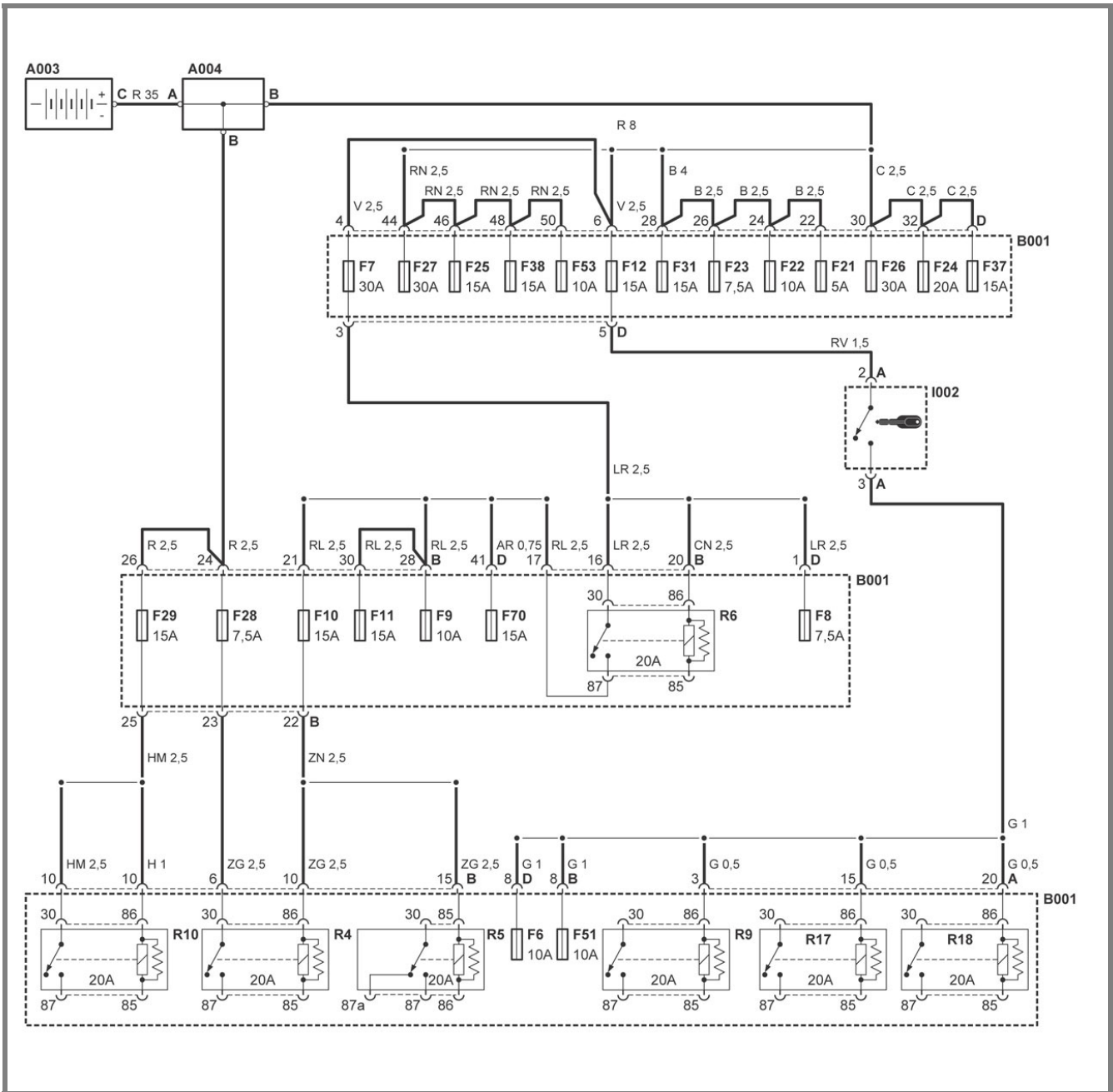

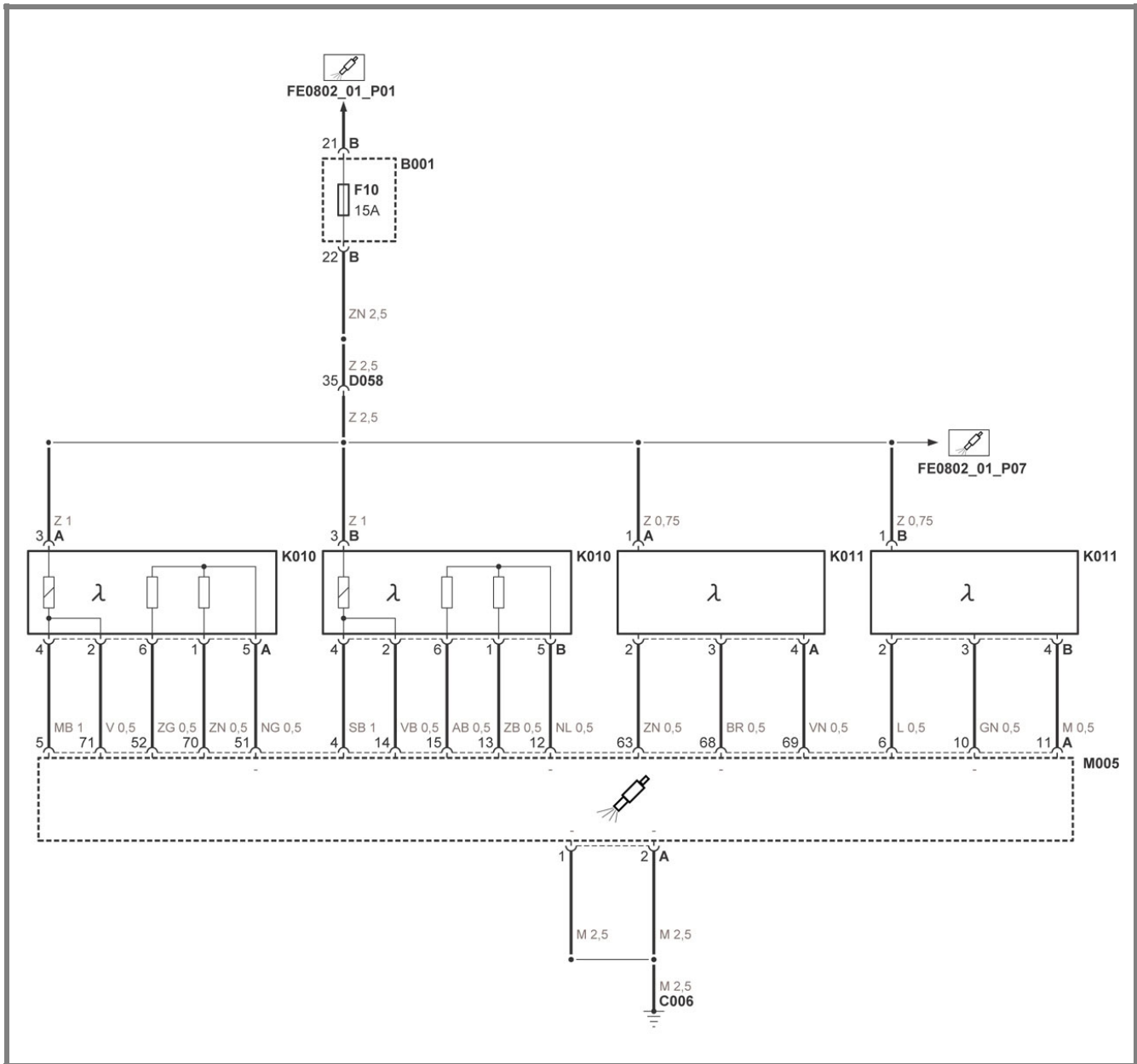

## ELECTRICAL COMPONENTS - DESCRIPTION

A002	12V starter motor
A003	Battery positive
A004	Branch terminal board
B001	Dashboard branching ecu (CPL)
B004	Fuses ecu (MAXI FUSE)
C004	Fuel tank earth
C005	Coils earth
C006	Injection system earth
C013	Luggage compartment wiring earth
C014	Robotized gearbox node earth
C018	Gearbox oil motor pump's earth
C019	Gearbox solenoid valves' earth
C025	Engine compartment wiring earth
D001	Dashboard/passenger compartment wiring connections
D004	Front door wiring connection
D018	Passenger compartment/luggage compartment wiring connection
D025	Luggage compartment wiring/F1 robotized gearbox cable bundle connection
D038	Injection/ engine compartment wiring connection
D054	OBD connection
D058	Dashboard /Injection wiring connection
D059	Passenger compartment/fuel tank cable bundle connection
I001	Steering column switch
I002	Ignition switch
I018	Reverse gear engagement control set
I023	Electronically controlled gearbox lever
I034	Gearshift control cluster on steering wheel
J008	Clutch pedal switch
J015	Inertia switch
J016	Stop indicator switch

## PASSENGER COMPARTMENT WIRING

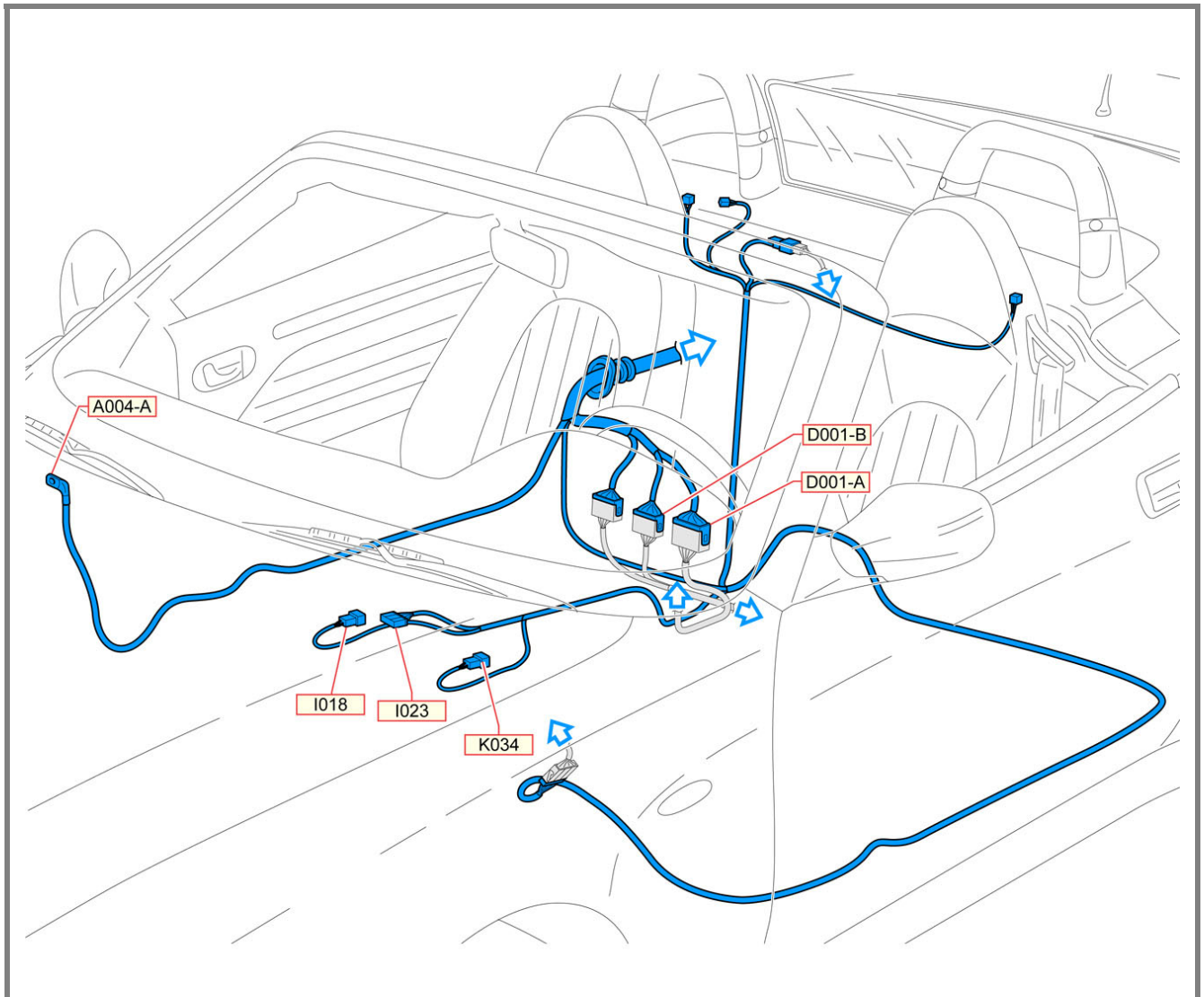



CLICK HERE TO **DOWNLOAD** THE COMPLETE MANUAL

- Thank you very much for reading the preview of the manual.
- You can download the complete manual from: [www.heydownloads.com](http://www.heydownloads.com) by clicking the link below



- Please note: If there is no response to CLICKING the link, please download this PDF first and then click on it.

CLICK HERE TO **DOWNLOAD** THE COMPLETE MANUAL