

# **Model 3000 Corn Header Workshop Service Manual**

CLICK HERE TO **DOWNLOAD** THE COMPLETE MANUAL

- Thank you very much for reading the preview of the manual.
- You can download the complete manual from: [www.heydownloads.com](http://www.heydownloads.com) by clicking the link below



- Please note: If there is no response to CLICKING the link, please download this PDF first and then click on it.

CLICK HERE TO **DOWNLOAD** THE COMPLETE MANUAL

**Safety Decals, Lights, and Reflectors**



**CAUTION:** The following warning signs, lights, and reflectors are placed at strategic positions on the Corn Head and or combine to provide the operator with a continual reminder of correct operating practices. If they become damaged or lost, replace them immediately. They may be obtained from your local AGCO dealer. The part number and location on the combine or Corn Head are listed under each safety sign.

Item	Part Number	Description	Quantity
1	71350770	Decal, Danger Ram Stop	1
2	71350365	Decal, Danger Snapping Rolls	2
3	71192887	Decal, Warning Drive Shieldp	1
4	70596071	Decal, Warning Shipping	1
5	71389339	Decal, Warning Lift Hook	2
6	70591362	Decal, Warning Speed (8, 10, 12 row units only)	1
7	71359170	Decal, Danger Drive Line	2
8	71359119	Decal, Danger Drive Line (under shield)	2
9	700722000b	Decal, Informational Lubrication	1
10	528934	Reflector Strip, Yellow	2
11	528933	Reflector Strip, Red	2 (4 on 12-Row units)
12	528938	Reflector Strip, Orange	2 (4 on 12-Row units)

**FIG. 5:** Safety sign, 1.



**FIG. 5**

## GENERAL INFORMATION

**FIGS. 31–33: Open Inner Gather Assembly 12-Row 20 and 22 inch:** Raise Corn Head and set header lift cylinder stop. Reach under divider point, pull quick pin (1), and then remove retaining pin (2).

Raise divider and remove prop rod (3) from prop rod keeper (4).

Use prop rod (3) placed securely in row unit assembly.

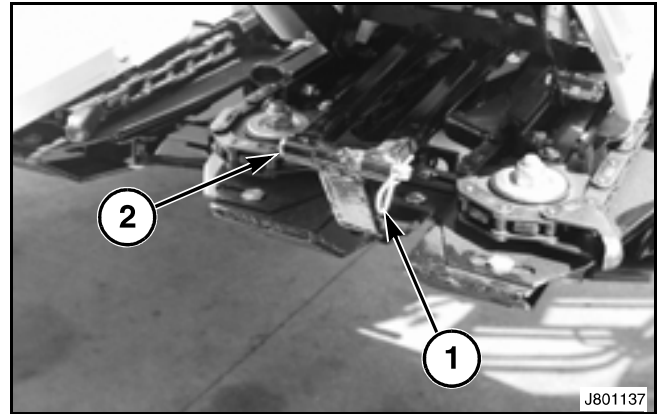


FIG. 31

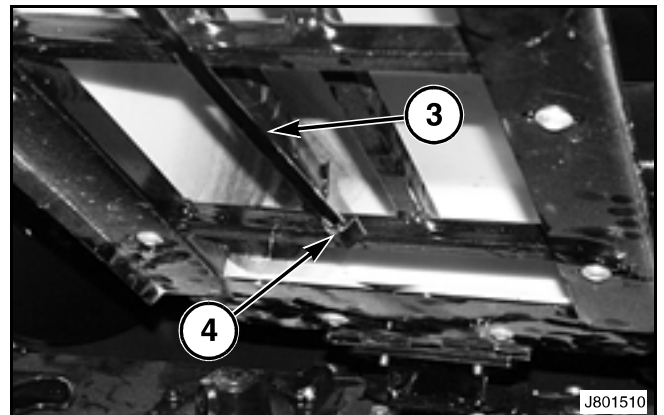


FIG. 32

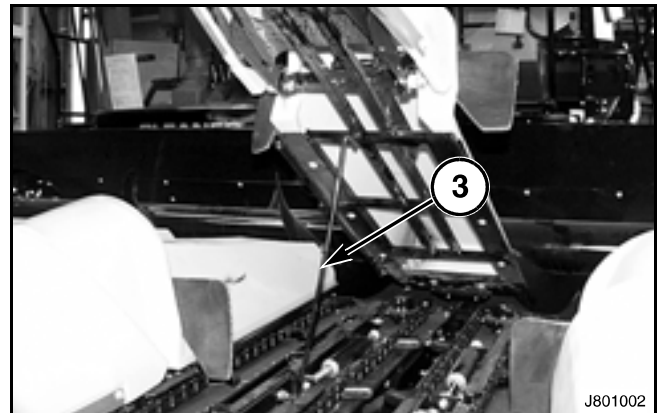


FIG. 33

**FIG. 34: Close Inner Gather Assembly:** Position pin (1) so that it is offset from the hole so that the pin is in the open position.

Store the prop rod in keeper and install quick pin in storage hole.

Lower gather assembly and then lock gather assembly in position by engaging pin (1).

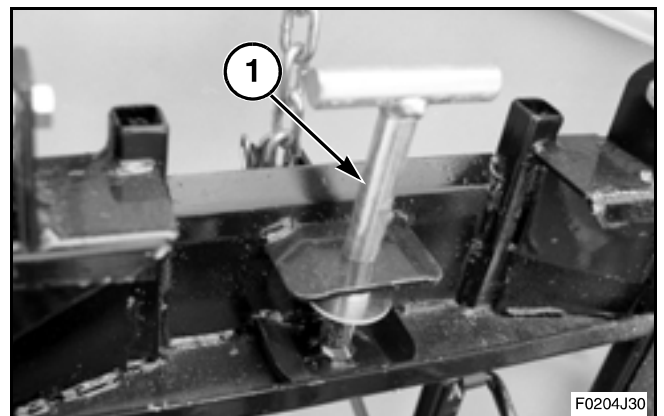


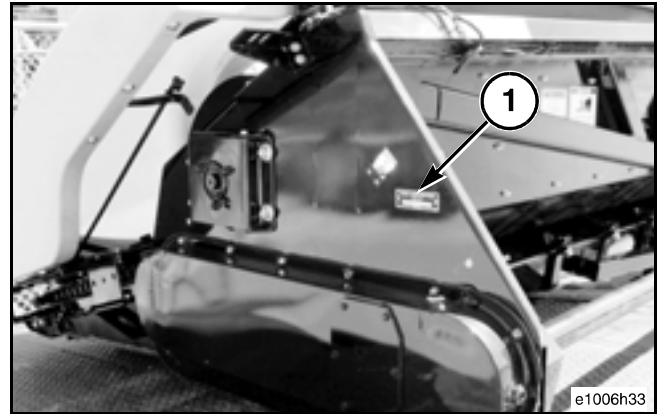
FIG. 34

## Specifications

### Header Identification

**FIG. 57:** Each header is identified by a model number and a serial number which are important and should be quoted when ever service or parts are required.

The model number/serial number is stamped on a plate (1) located at the Left Hand end of the header frame.



**FIG. 57**

**FIG. 58:** The first three or four digits, as required, designate the header size and type. A "dash" following the fourth digit, designates a conventional or an axial combine, while an "R" following the fourth digit designates a transverse combine. The letter following the "dash" or "R" designates the location of manufacture ("H" for Hesston). The last six digits designate the model year and serial number.

Example: 1230-HM84101 (XXXX-XXXXXXX)

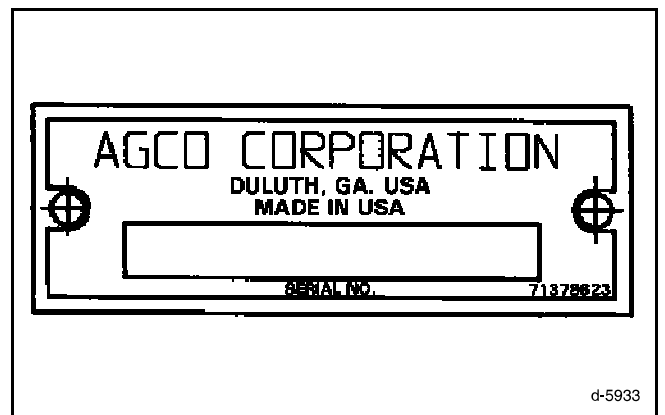
"1230" - Header size (12-Row 30 inch spacing)

"-" - Axial or Conventional Combine

"H" - Hesston

"M" - 2003 Model Year

" 27101" - consecutive serial number

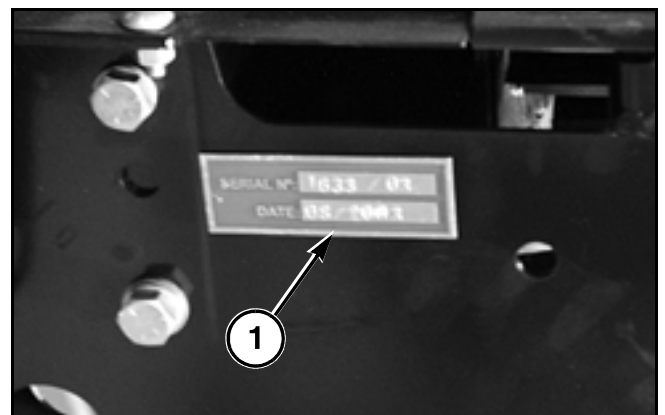


**FIG. 58**

### Row Unit Identification

**FIG. 59:** Each row unit is identified by a serial number and a date which are important and should be quoted when ever service or parts are required.

The serial number is stamped on a plate (1) located toward the rear of the Right Hand row unit frame.



**FIG. 59**

### Care of Roller Chains

**FIG. 72:** When using spring clip connectors, always install the spring clip with the open end of clip trailing the direction of chain travel to prevent accidental removal or loss of the spring clip.

When the machine is new, check the alignment of chain drives with a straight edge or light wire held against the faces of the sprockets and move one or both sprockets as required. Observe the chain and sprocket teeth periodically and check the alignment if excessive wear shows on the sides of the sprocket teeth and on the inside of the chain side bars.

Don't run chains too tight or too loose. Tight chains cause excessive loads on bearings. Loose chains cause noisy operation, chain pulsations or whipping and result in irregular sprocket speeds and abnormal wear. Adjust the idlers to take the looseness out of the chains without inducing any pre-load tension.

Lubricate chains with AGCO chain and cable lube or light engine oil at least once every 8 to 10 hours of operating time. Apply lubricant liberally when the chain is warm, then let the excess oil drain off before operating the combine.

Keep chains clean. Check the chain and sprocket teeth for accumulations of dirt or foreign materials and for signs of corrosion. Foreign material packed into the chain or sprocket teeth may cause chain or sprocket breakage.

### Roller Chain Don'ts

Never insert a new link in a chain that has been lengthened greatly by wear. The bite of the new link will be different and the resulting shock, each time the link engages the sprockets, will soon destroy the chain.

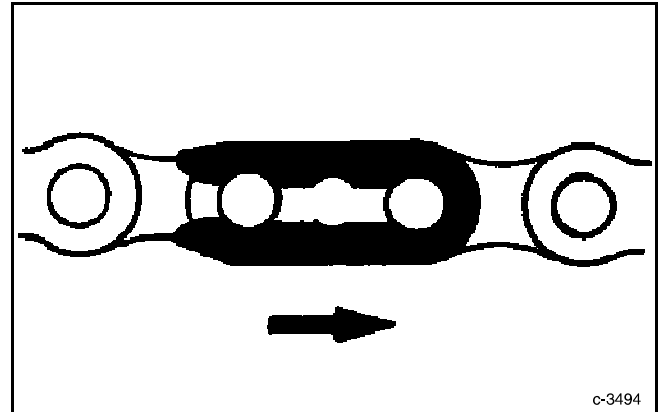
When installing a link, don't drive the connecting link plate down too far on pins. This squeezes the chain joint so no oil can get down in between the link plates, keeping joints from flexing and results in whipping.

Don't install a new chain on badly worn sprockets. A few hours operation under such conditions will do more damage to the chain than many hours of normal use.



**CAUTION:** The chain should not come in contact with solvents such as gasoline, benzene, acetone, or other corrosive materials as this may have an adverse effect on the O-rings.

**NOTE:** Connecting link must be installed with open end away from direction of travel.



**FIG. 72**

## Outer Fenders

**FIGS. 94–95: All Units Other Than 12-Row 20 and 22 inch:** Outer fenders are installed at the factory.

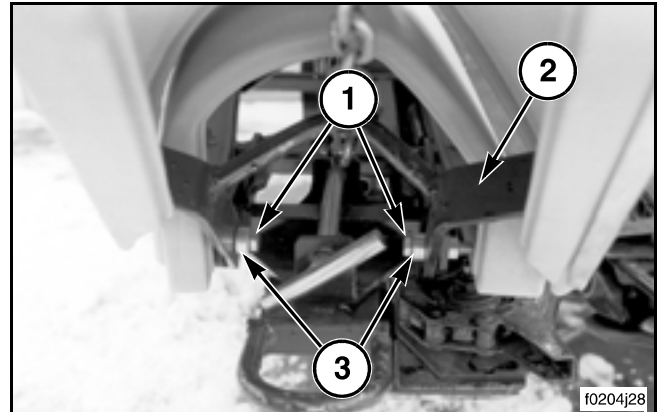
Remove the two 7/16-14 X 2.0 inch pivot capscrews (1) with shouldered bushings and center lock nuts provided in the shipping configuration of the outer fender points.

With the shoulder of the bushing to the inside, insert bushing (3) from inside of divider point frame into pivot point (2).

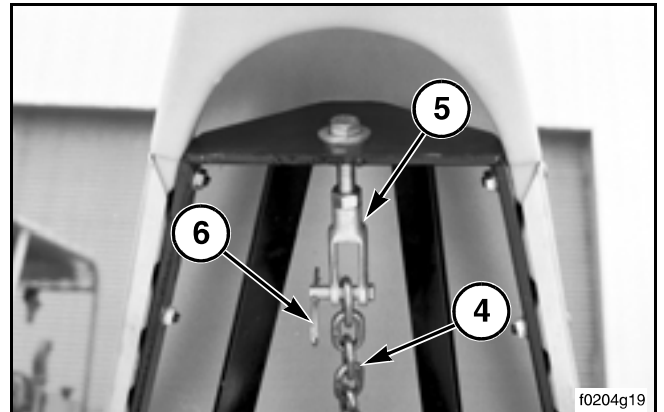
Position fender point with bushings into gather sheet frame and align pivot points. Insert the two 7/16-14 X 2.0 inch capscrews (1) from inside to outside and secure each with a center lock nut. Tighten lock nuts securely.

Attach the outer end of chain (4) provided in the shipping configuration of the fender to the divider point clevis (5) and secure using clevis pin. Insert quick pin (6) to retain clevis pin.

*NOTE: After header has been mounted on combine, refer to "ADJUSTMENT"..."Divider Points" for procedure to set divider point height.*



**FIG. 94**



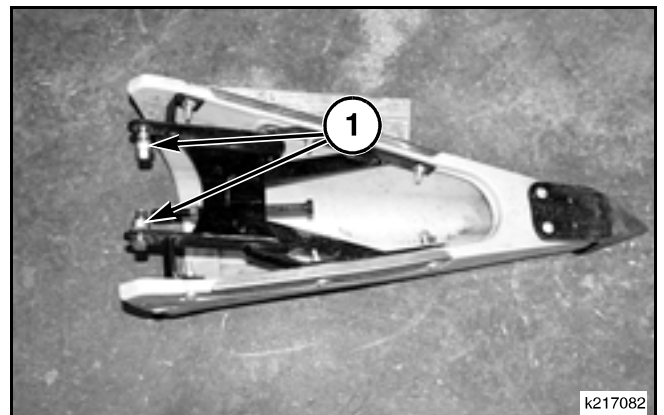
**FIG. 95**

**FIG. 96: 12-Row 20 and 22 inch Unit:** Outer fenders are shipped loose from the factory.

*NOTE: 1. Snouts not attached to outer fender.*

*2. The outer gathering unit (fender) snout can best be installed with the fender removed from the corn head.*

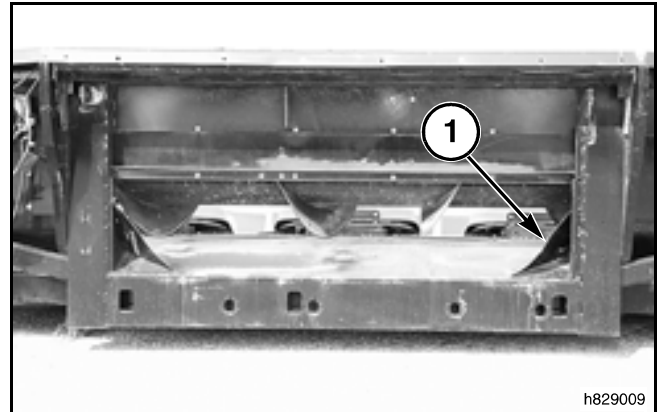
Remove the two 7/16-14 X 1-3/4 inch pivot capscrews (1) with shouldered bushings and center lock nuts provided in the shipping configuration of the outer fender points.



**FIG. 96**

## Setup to Fit Conventional or Axial Corn Head on Transverse Combine

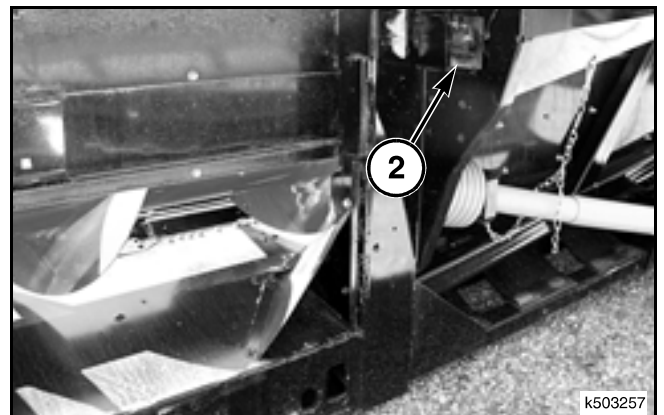
**FIG. 121:** Retain deflector panel (1) in Right Hand side of feed housing opening.



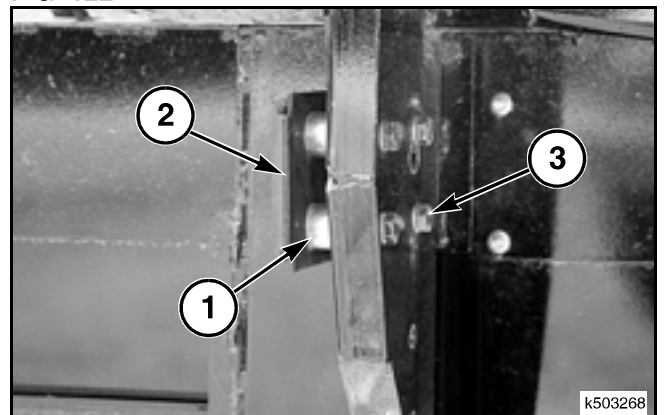
**FIG. 121**

**FIGS. 122–123:** Remove the Right Hand guide (2) by removing the four 1/2-13 X 1-1/4 inch hex flange serrated screws securing guide to Right Hand post weldment.

Reattach the Right Hand guide (2) with spacers (1) to the Right Hand post weldment using four 1/2-13 X 2-3/4 inch hex flange serrated screws (3).



**FIG. 122**



**FIG. 123**

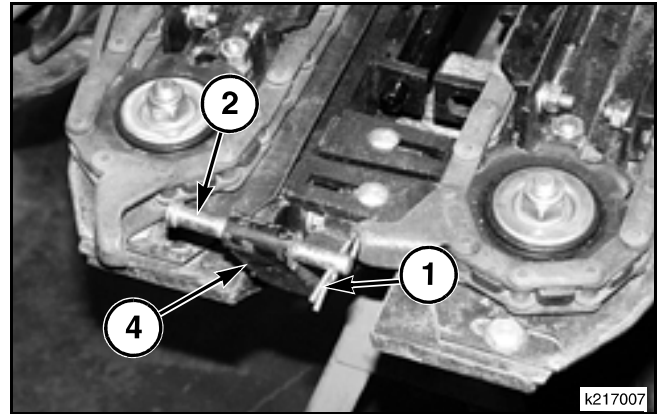
## ADJUSTMENTS

**FIGS. 9–10–11: 12-Row 20 and 22 inch:** Remove quick pin (1) then retainer pin (2) from clevis arm (4).

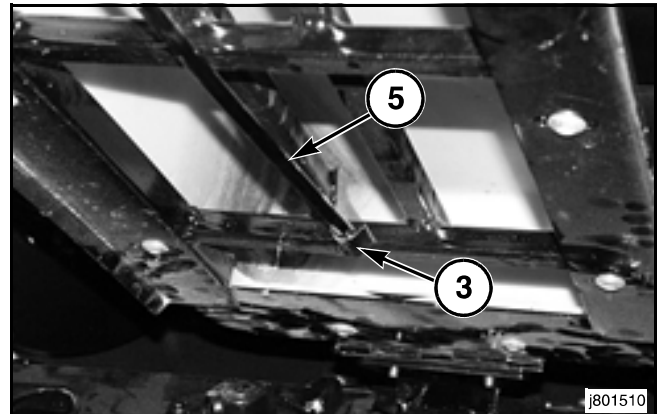
*NOTE: Unit may use a 7/16-14 X 4-1/2 inch capscrew with a center lock nut to retain front of gather sheet to clevis arm (4).*

Place prop rod (5) into the prop rod keeper (3).

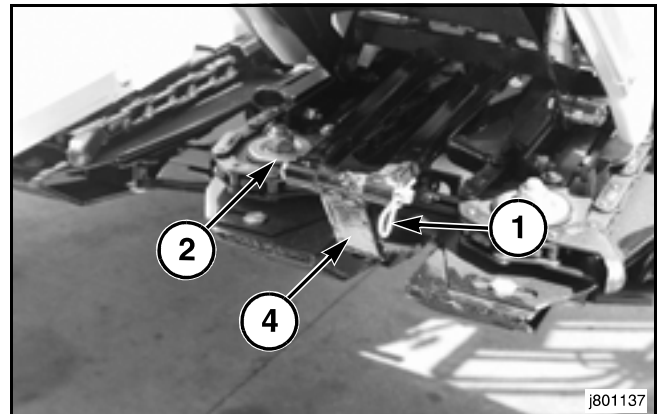
Reach under divider point then insert retainer pin (2) into gather frame and clevis arm (4). Secure retainer pin (2) using quick pin (1).



**FIG. 9**



**FIG. 10**



**FIG. 11**

## Gather Chain

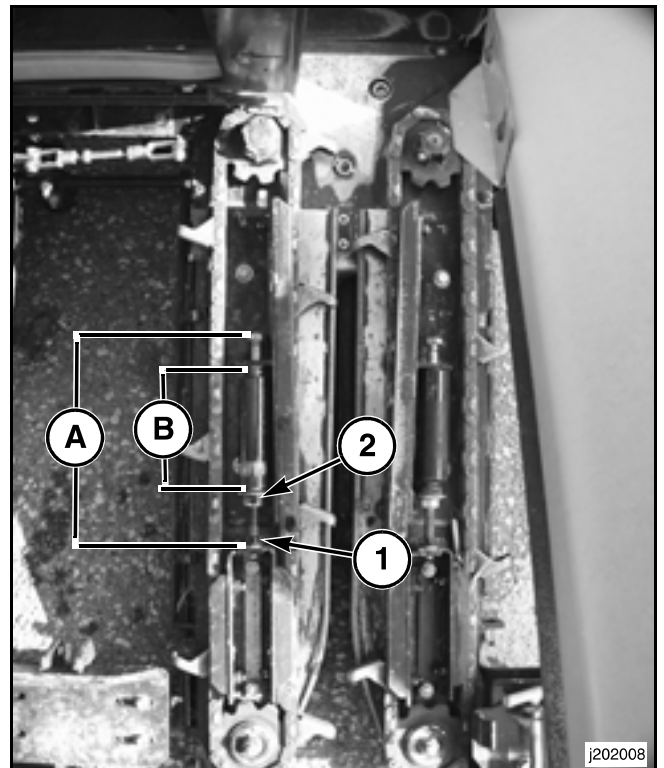
### Gather Chain Spring Tension

**FIG. 32:** Adjust 5/8-11 flange top lock nut (1) at rear of front chain guide to obtain a dimension (A) of 291 mm (11.45 in) from front side of 5/8-11 X 12 inch gather chain spring bolt head to rear side of front chain guide.

Adjust 5/8-11 flange top lock nut (2) on front side of spring washer to obtain a dimension (B) of 160 mm (6.30 in) from front side of the spring washer to front side of rear spring stop.

*NOTE: As the gather chains wear, dimension (B) will increase which decreases the spring tension on the gather chains and increases the possibility of the chains coming off of the sprockets.*

*NOTE: Check dimension (B) twice each year for chain wear.*



**FIG. 32**

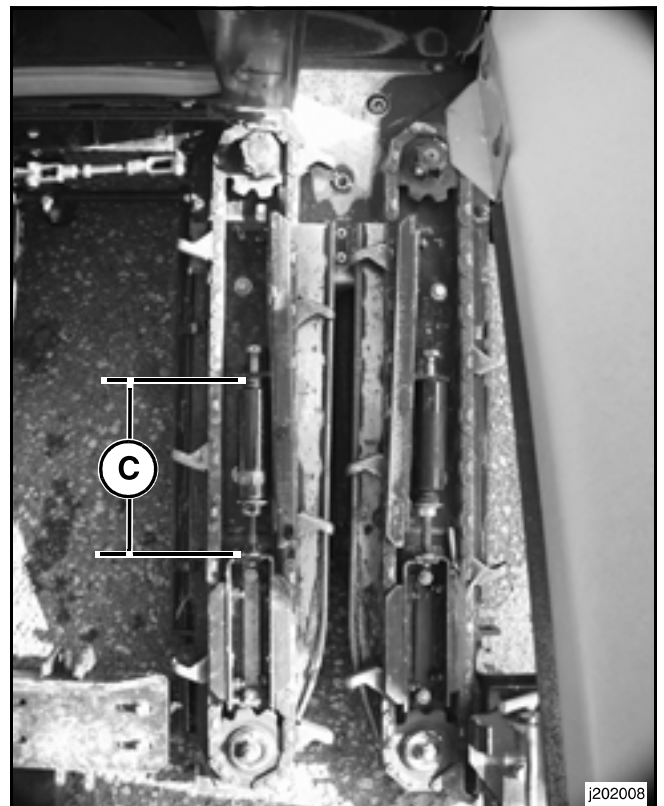
### Gather Chain Length

**FIG. 33:** As the gather chain wears, the front idler assembly moves forward in a slot in the stripper plates.

*NOTE: If dimension (C) exceeds 265 mm (10.43 in), the front chain guide and idler assembly will bottom out on the front side of the slots in the stripper plates which prevents the gather chain spring from keeping the chains under tension.*

If dimension (C) between rear of front chain guide and front of rear spring stop reaches 265 mm (10.43 in) the offset link should be removed from gathering chain.

*NOTE: Purchase repair link from your local dealer.*

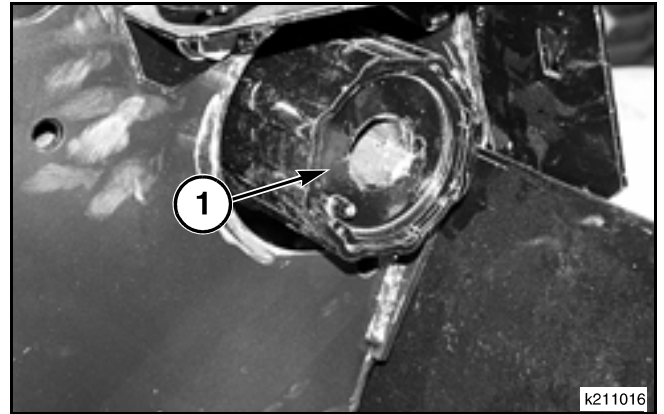


**FIG. 33**

## Slip Clutches

### Torque Limiter

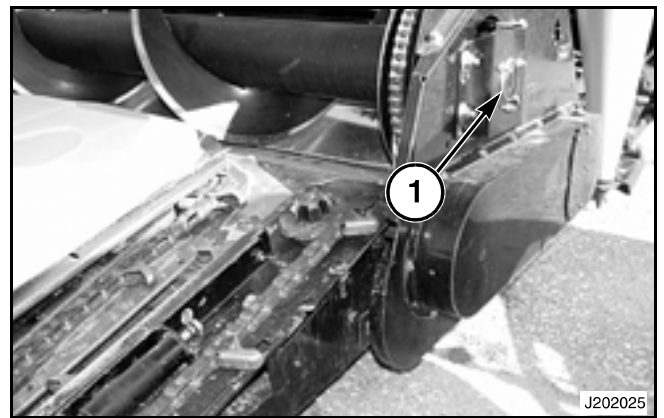
**FIG. 56:** There is a radial pin torque limiter (1) located on the input shaft of each row unit gearbox. No adjustment is required.



**FIG. 56**

### Conveyor Drive

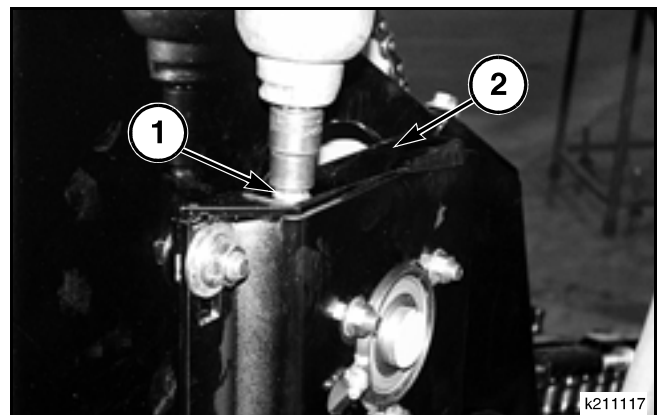
**FIG. 57:** Conveyor drive slip clutch (1) is located on the Left Hand end of all model Corn Heads and also on the Right Hand end of the 12 row 30 inch Corn Head. Four springs are used on the 4-row Corn Head and six springs for all other models.



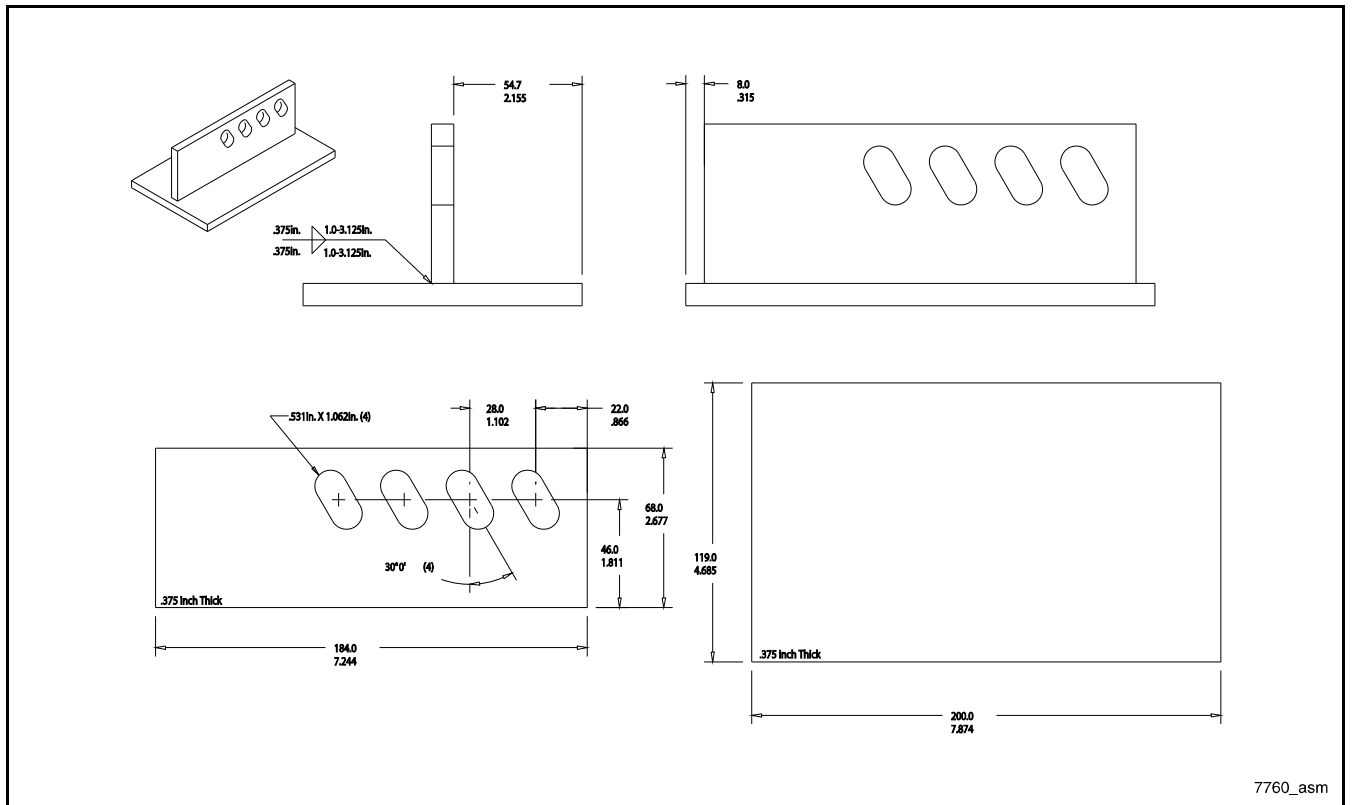
**FIG. 57**

**FIG. 58:** Loosen 5/16-18 X 1/2 inch hex flange self tapping screw (1) securing slip clutch shield (2). Swing shield to the outside to observe conveyor slip clutch.

Spring length is set at 43 mm (1.69 in) and should be reset at this length if disassembled.



**FIG. 58**



**FIG. 80**

## Row Units

**FIG. 80:** A row unit lifting bracket can be made to effectively support row unit while positioning to change row spacing.

See figure for details required to fabricate, fixture, and weld lifting bracket.

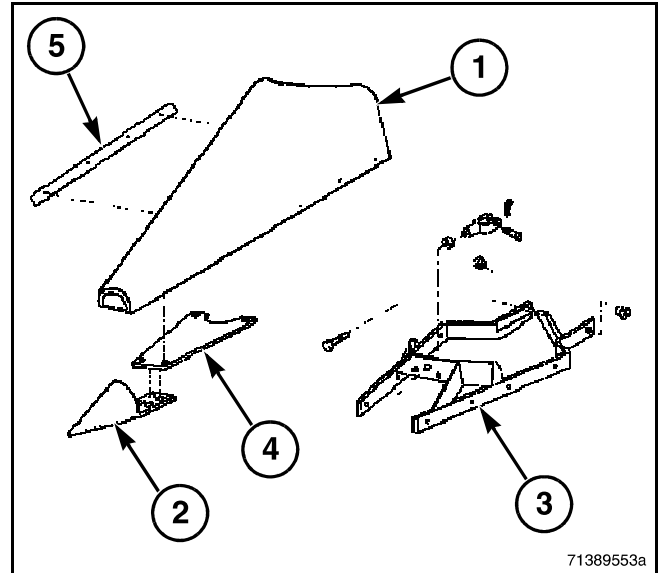
**FIG. 8: Fender Sheet Points:** Remove five 5/16-18 X 7/8 inch T40 torx head tapping screws with flat washers and serrated flanged nuts from row side of plastic (1) securing left or right wear strip (5) and frame weldment (3). Remove wear strip from plastic.

Remove three 5/16-18 X 7/8 inch T40 torx head tapping screws with flat washers and serrated flanged nuts from opposite side securing frame weldment (3) to plastic (1). Remove frame from plastic.

Remove front two 5/16-18 X 7/8 inch T40 torx head tapping screws with flat washers and rear two 5/16-18 X 1-1/4 inch serrated flanged hex head capscrews with flat washers and serrated flanged nuts securing point (2) to plastic (1). Remove point from plastic.

Remove rear two 5/16-18 X 7/8 inch T40 torx head tapping screws with flat washers and serrated flanged nuts securing bottom plate (4) to plastic (1). Remove plate from plastic.

The plastic can now be replaced or repaired.

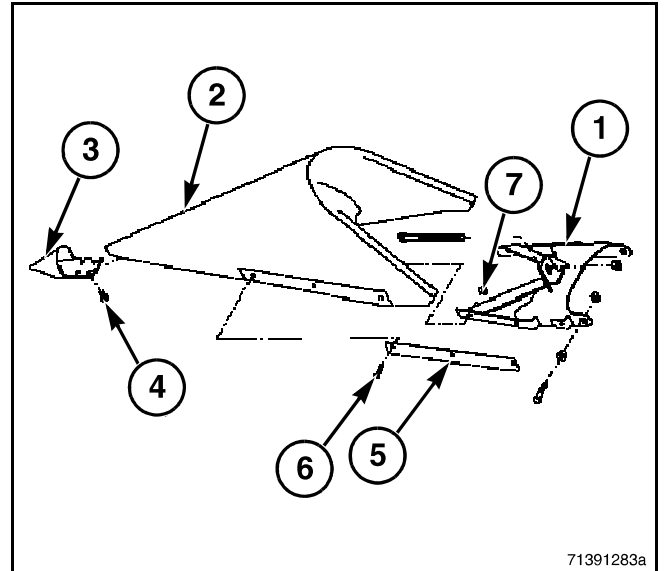


**FIG. 8**

**FIG. 9: Fender Sheet (20 and 22 inch) Points:** Remove three 5/16-18 X 1-1/2 inch T40 torx head tapping screws (6) and serrated flanged nuts (7) from each side of plastic (2) securing left or right wear strip (5) and frame weldment (1). Remove wear strip and frame from plastic.

Remove the two 5/16-18 X 7/8 inch T40 torx head screws (4) securing point (3) to plastic (2). Remove point from plastic.

The plastic can now be replaced or repaired.



**FIG. 9**

Installation

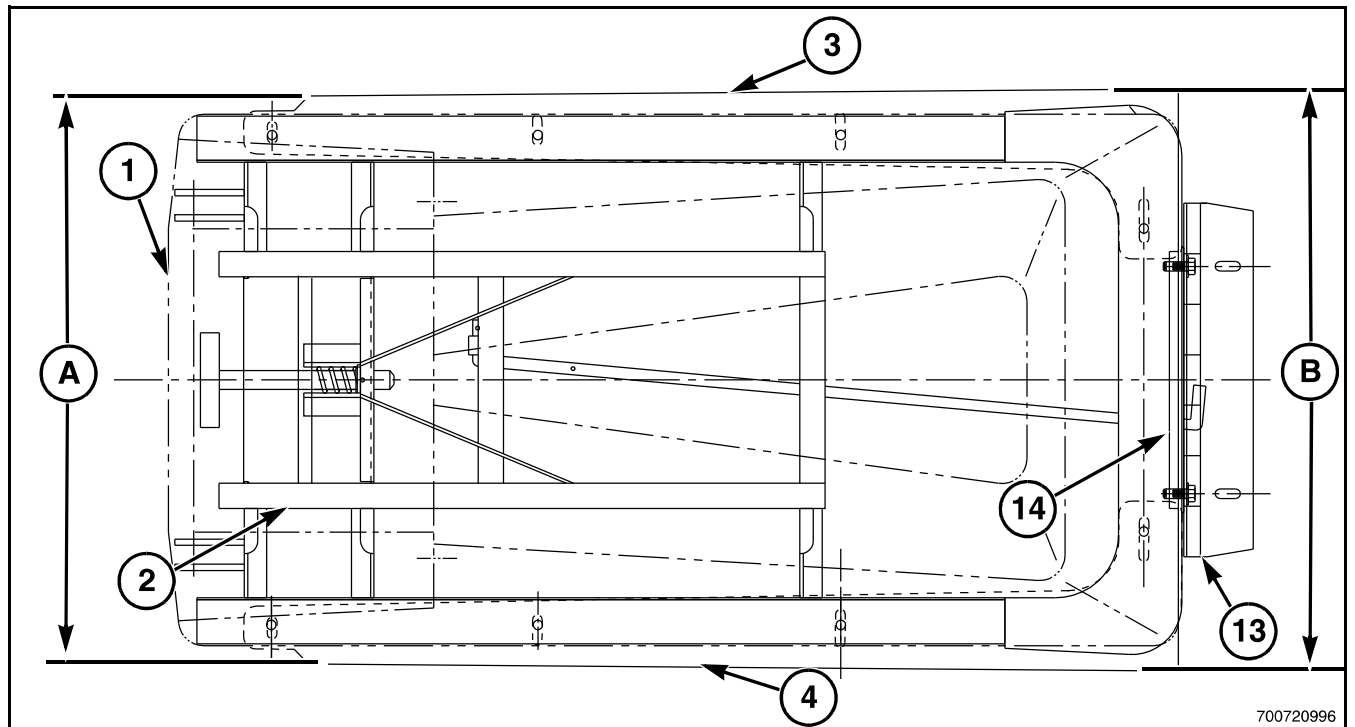


FIG. 34

**FIG. 34: Inner Gathering Sheet 30, 36, and 38 inch Row:** Position frame weldment (2) onto bottom side of plastic gathering sheet (1). Position left (3) and right (4) side rails onto the frame with break in rail edge facing away from the frame.

Loosely install the eight 5/16-18 X 1-1/4 inch capscrews with flat washer and flange hex nut to secure left (3) and right (4) side rails and frame weldment (2) to plastic (1).

Center the rails on the plastic gathering sheet with the following dimensions over the outer front (A) and rear (B) edge and tighten hardware.

30 inch Row Unit: (A) of 609 mm (24 in.) and (B) of 622 mm (24-1/2 in.)

36 inch Row Unit: (A) of 762 mm (30 in.) and (B) of 775 mm (30-1/2 in.)

38 inch Row Unit: (A) of 813 mm (32 in.) and (B) of 825 mm (32-1/2 in.)

Place threaded hinge bar (14) inside rear surface of plastic (1) aligned with holes in plastic and upper (short) hinge (13) positioned on the outside. Loosely install the two 3/8-16 X 1-1/4 inch capscrews with lock washer and flat washer securing hinge assembly (13) and threaded hinge bar (14) to gather plastic (1).

*NOTE: Position hinge to provide 11 to 16 mm (7/16 to 5/8 inch) vertical gap between edge of rail and row unit chain guide when gathering sheet is mounted on row unit. Tighten hinge hardware.*

**FIG. 66:** The divider point (1) can be removed following the procedure found in "SERVICE - GENERAL"... "Divider Points"... "Removal" section in this section of the manual.



**FIG. 66**

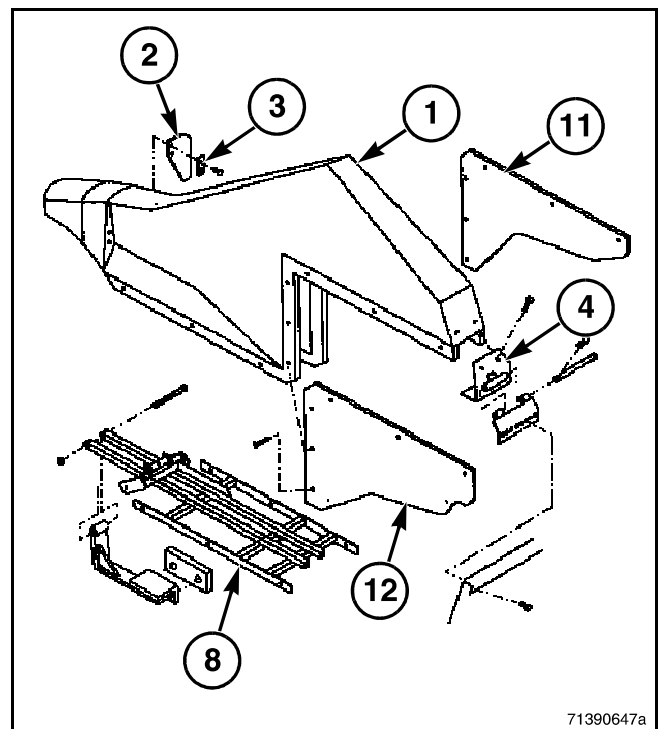
**FIG. 67:** Remove the two 5/16-18 X 7/8 inch T40 torx head tapping screws threaded into inserts in the plastic to remove rear hinge (4).

To remove outside poly plastic shield (12), remove the six 5/16-18 X 1-1/2 inch T40 torx head tapping screws with hex serrated flange nuts securing plastic shield (12) to fender plastic sheet (1). Repeat procedure for inside poly plastic shield (11).

Remove the six 5/16-18 X 1-1/2 inch T40 torx head tapping screws with hex serrated flange nuts securing fender frame weldment (8) to inside of fender plastic (1). Remove frame from inside of plastic.

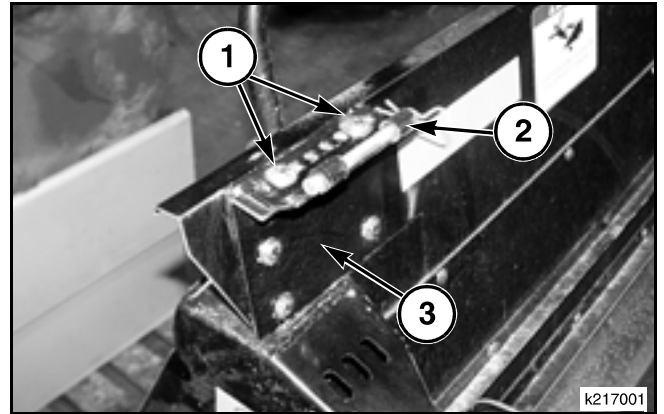
Remove the two 5/16-18 X 3/4 inch capscrews with internal tooth lock washers securing each ear deflector reinforcement (3) and rubber ear deflector (2) to inserts in the gather plastic (1). Remove reinforcements and ears from plastic.

The plastic can now be repaired or replaced.



**FIG. 67**

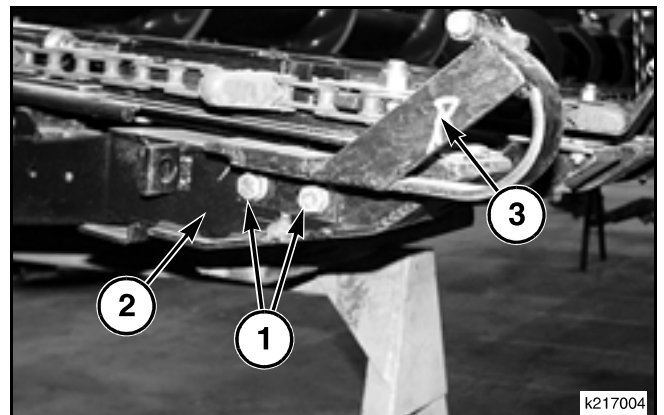
**FIG. 94:** Loosely install the two 5/16-18 X 3/4 inch capscrews (1) with hex serrated flange nuts to secure frame hinge (2) to hinge fender angle (3). Do Not tighten at this time.



**FIG. 94**

**FIG. 95:** Loosely install the two 1/2-13 X 1-1/4 inch hex flange capscrews (1) to secure front fender mount (3) to row unit frame (2). The hardware will be tightened after outer gathering sheet is installed and front latch pin aligned.

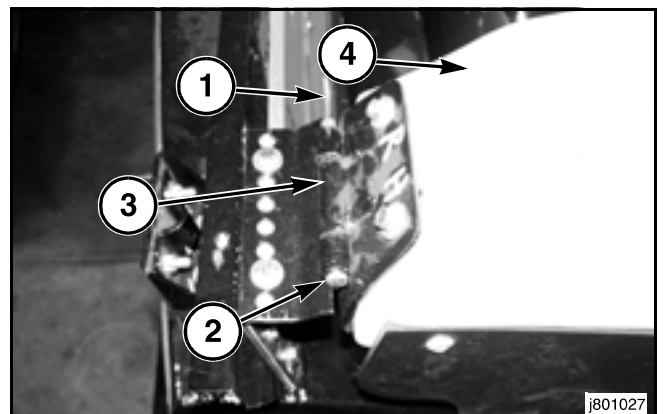
*NOTE: The 22 inch row unit uses two 1/2-13 X 1-3/4 inch hex flange capscrews (1) and a spacer between mount (3) and frame (2).*



**FIG. 95**

**FIG. 96:** Using an assistant or a suitable lifting device, position outer gathering sheet (fender) (4) onto corn head.

Insert pivot pin (2) into rear hinge assembly (3) and install rear hinge quick pin (1) into pivot pin (2).

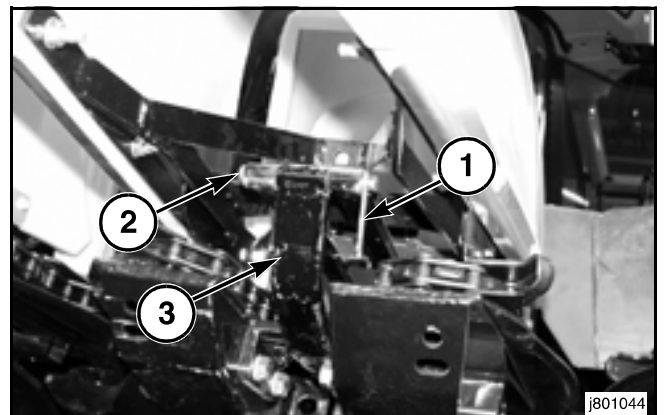


**FIG. 96**

**FIG. 97:** Insert front latch pin (2) and retain with quick pin (1).

*NOTE: Unit may use a 7/16-14 X 4-1/2 inch capscrew with a center lock nut to retain front of gather sheet to cleavis arm (3).*

Securely tighten the two 1/2-13 X 1-1/4 inch hex flange capscrews securing front mount and then securely tighten rear mounting hardware.



**FIG. 97**

CLICK HERE TO **DOWNLOAD** THE COMPLETE MANUAL

- Thank you very much for reading the preview of the manual.
- You can download the complete manual from: [www.heydownloads.com](http://www.heydownloads.com) by clicking the link below

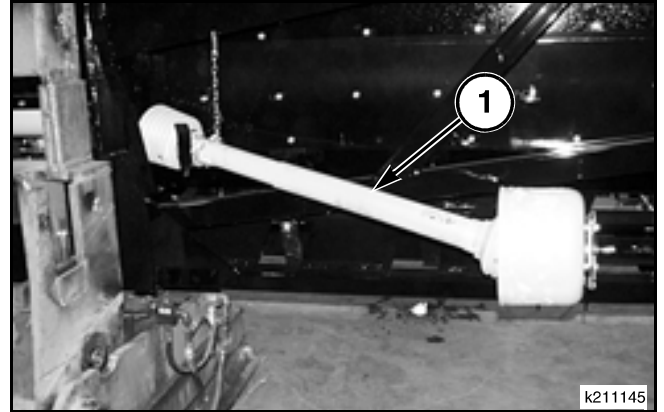


- Please note: If there is no response to CLICKING the link, please download this PDF first and then click on it.

CLICK HERE TO **DOWNLOAD** THE COMPLETE MANUAL

## Assembly

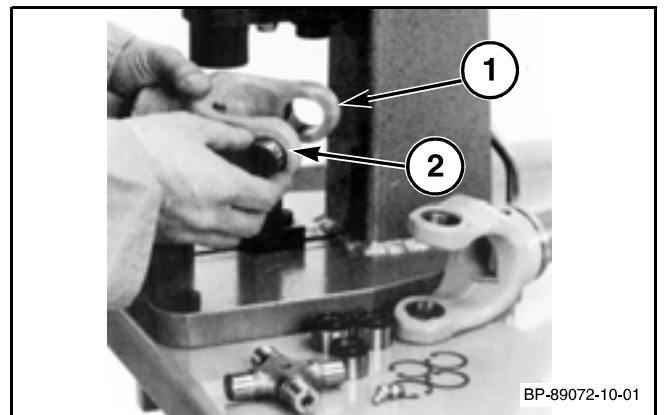
**FIG. 126:** Use the following procedure to re-assemble PTO drive shaft (1).



**FIG. 126**

**FIG. 127: PTO Cross and Bearings:** Remove the bearing caps from the new cross. Apply a light film of molybdenum-disulfide grease to the needle bearings in each bearing cap to help the needle bearings remain in position during assembly. Install the grease fitting in the cross.

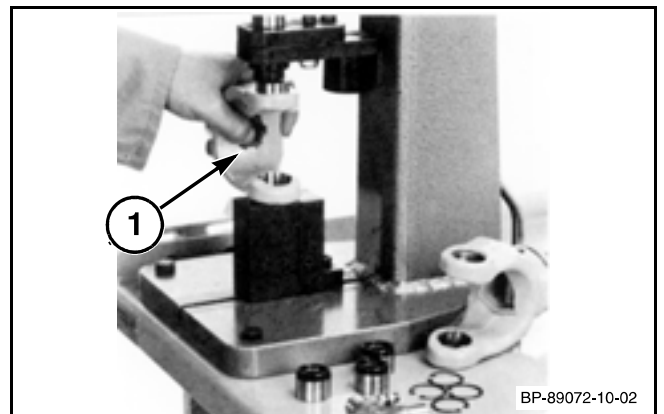
Start one of the new bearing caps (2) into the quick disconnect yoke (1).



**FIG. 127**

**FIG. 128:** Press the bearing cap into the quick disconnect yoke (1) approximately half the length of the bearing cap.

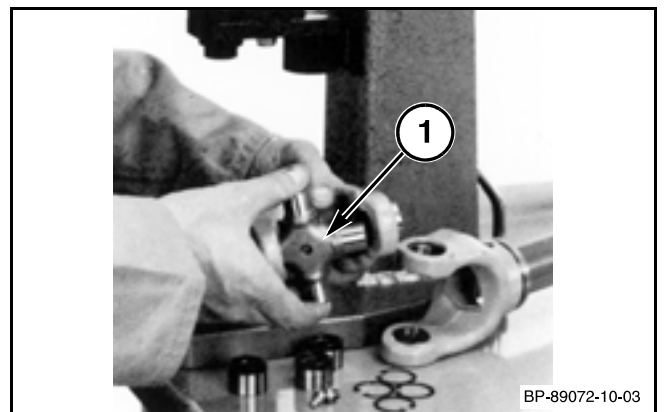
[BP89072-10-3] photo of disconnect yoke with bearing cross; 565A Baler service manual #700 713 096 section 2001



**FIG. 128**

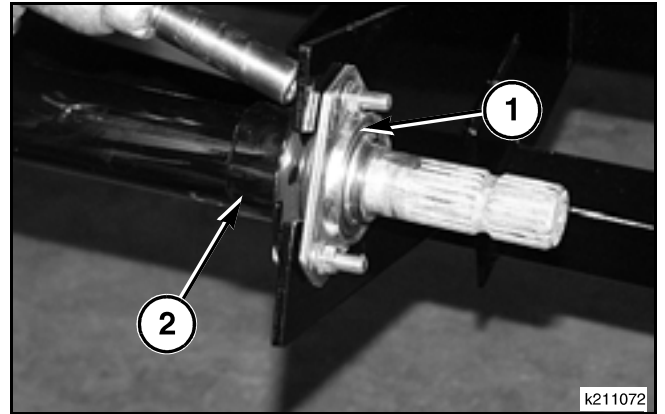
**FIG. 129:** Install the new cross into the bearing cap.

**IMPORTANT:** Yoke cross grease fittings to be oriented in yoke opening so they can be greased through shield holes with drive line assembled on shafts. Grease fitting orientation should be toward tube yoke.



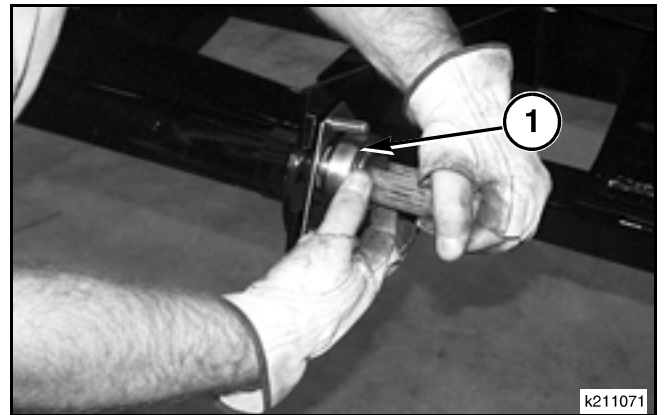
**FIG. 129**

**FIG. 162:** Remove the three 3/8-16 flanged nuts securing bearing assembly with flanges (1) and shaft shield support (2) to bearing support.



**FIG. 162**

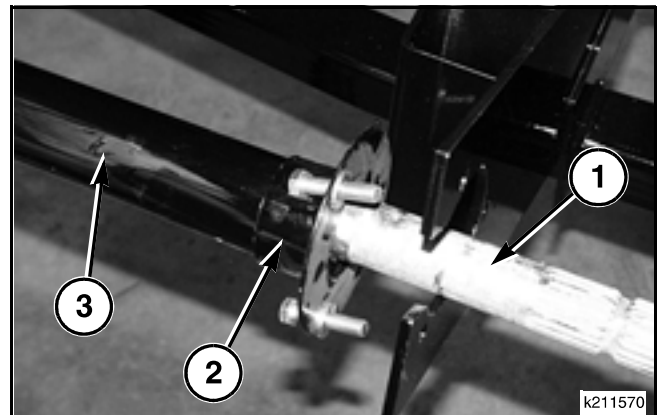
**FIG. 163:** Remove bearing assembly with bearing flanges (1) from Right Hand end of drive shaft.



**FIG. 163**

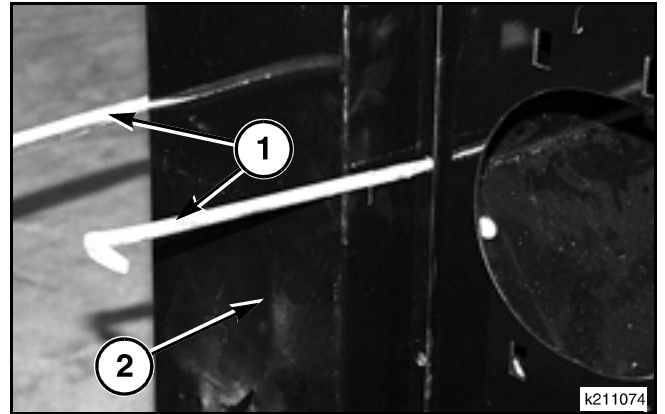
**FIG. 164:** Remove 3/8-16 X 1-3/4 inch capscrews and flat washers.

Slide Left Hand drive shaft (1) with shield supports (2) and drive shaft shield (3) to the right to remove from Left Hand bearing housing and then corn head.



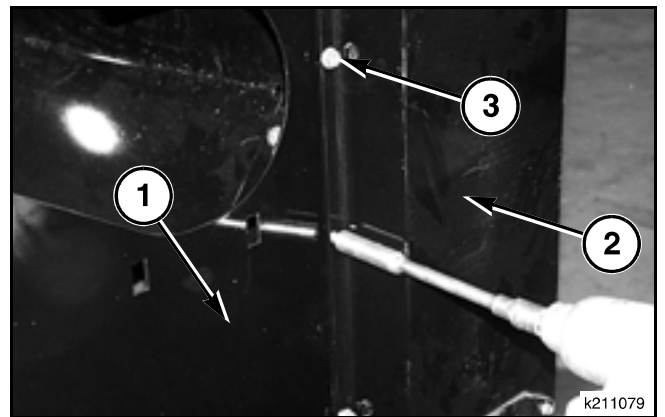
**FIG. 164**

**FIG. 197:** Using two tapered punches (1), position chain case (2) with cover to the rear onto the frame end sheet and align mounting holes.



**FIG. 197**

**FIG. 198:** Install the thirteen 5/16-18 X 1/2 inch hex flange head thread cutting tapping screws (3) securing cover (2) to end panel (1) of corn head frame and tighten securely.



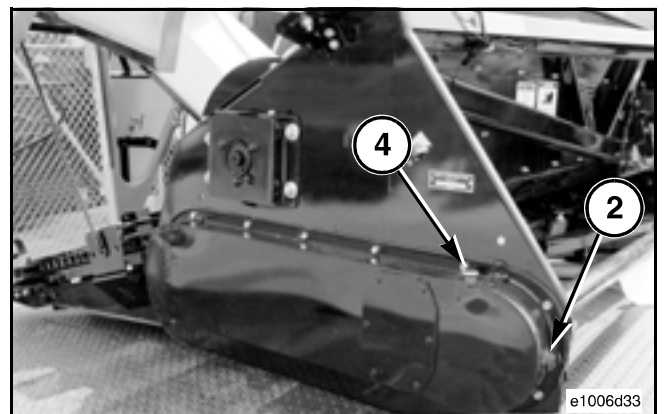
**FIG. 198**

**FIG. 199:** Ensure that the chain case has the equivalent of two 14 oz. tubes of grease.

**IMPORTANT:** Use only specified AGCO grease (AGCO Part No. 79014731, 5 gallons) or (79014732, 14 oz. tube) in drive chain reservoirs.

**NOTE:** Grease in reservoirs may be replaced with AGCO Power Lube 10W30 oil. Remove all grease from reservoirs prior to filling. If oil is used in reservoirs, check as follows:

Oil level should be checked at plug (2) with Corn Head attached to combine and in the fully raised position. If necessary, add oil at fill plug (4). Drain plug is located in bottom of reservoir.

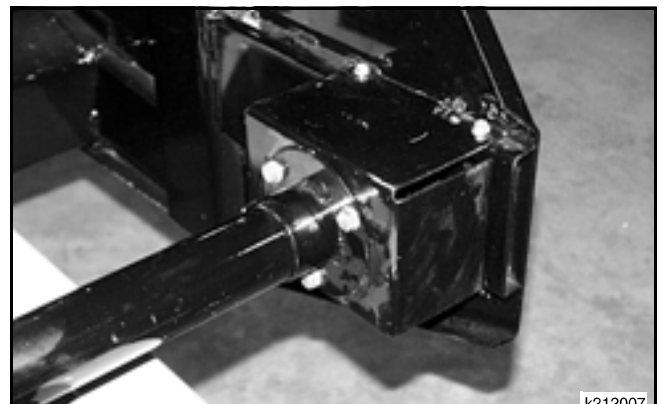


**FIG. 199**

**FIG. 200: Right Hand Main Drive 8-Row Unit Shown:** Repeat the above procedure to install Right Hand main drive onto the corn head.

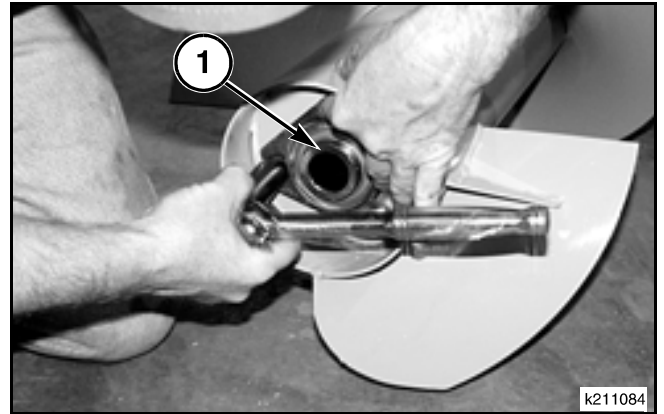
**NOTE:** All 8-Row units and all 12-Row 20 and 22 inch units have a Right Hand main drive for row units, but do not have a Right Hand conveyor drive. Only the 12-Row 30 inch unit has a dual conveyor requiring a Right Hand conveyor drive.

**NOTE:** All of the 4 and 6-Row units have only a Left Hand main drive for row units and conveyor.



**FIG. 200**

**FIG. 235:** If auger inner hex shaft bearing (1) is to be replaced, remove the three 3/8-16 X 1.0 inch capscrews with lock washers and remove the bearing assembly with flanges.



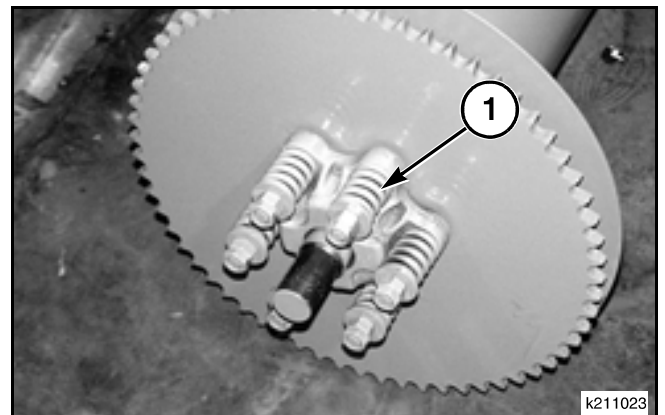
**FIG. 235**

### Disassembly - Slip Clutch

**FIG. 236:** All units except 12-Row 30 inch head have a single conveyor auger with a slip clutch mounted to Left Hand end of conveyor.

The 12-Row 30 inch head has dual augers with a slip clutch mounted at the end of each conveyor.

Four springs (1) are used on the 4-Row Corn Head and six springs for all other models.



**FIG. 236**

**FIG. 237:** Loosen and remove 1/2-13 inch jam nuts (1). Remove all the 1/2-13 hex nuts gradually to release spring pressure and remove flat washers.

*IMPORTANT: Loosen all of the nuts gradually to prevent uneven spring pressure from binding pressure cap on pins and thread damage.*

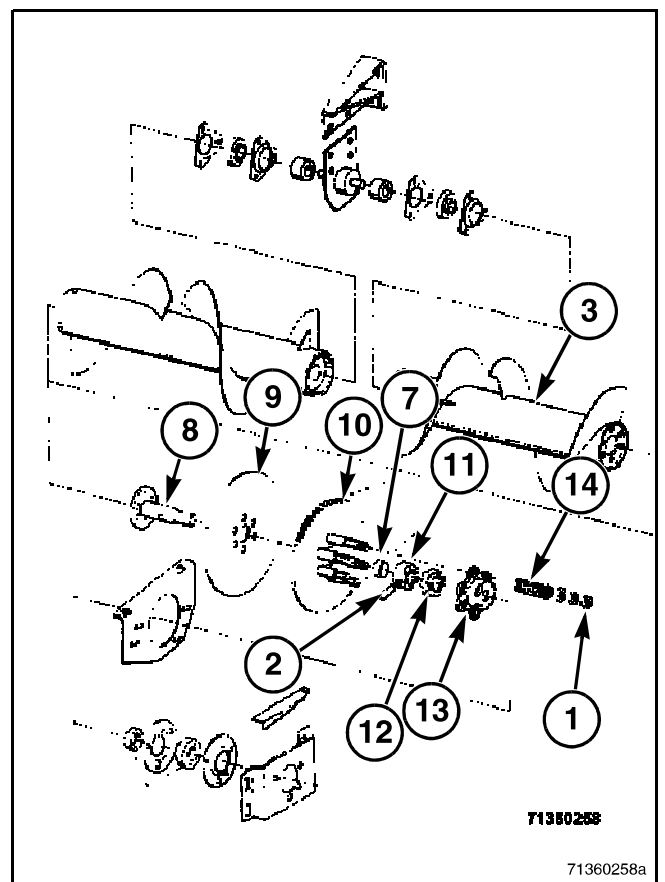
Remove springs (14) and pressure cap (13) from pins on sprocket assembly (10).

Remove drive clutch jaw (12) from conveyor shaft (8).

*NOTE: Removing paint and corrosion from the shaft will make removal and installation of clutch jaws and driven sprocket easier.*

Remove 0.499/0.500 X 2-7/8 inch clutch pin (2) retaining driver clutch jaw (11) to conveyor shaft (8) and remove clutch jaw. Slide sprocket assembly (10) from conveyor shaft (8).

Remove the six 3/8-16 X 1.0 inch capscrews with lock washers securing sprocket shield (9) and conveyor shaft (8) to bulk head in conveyor tube (3).

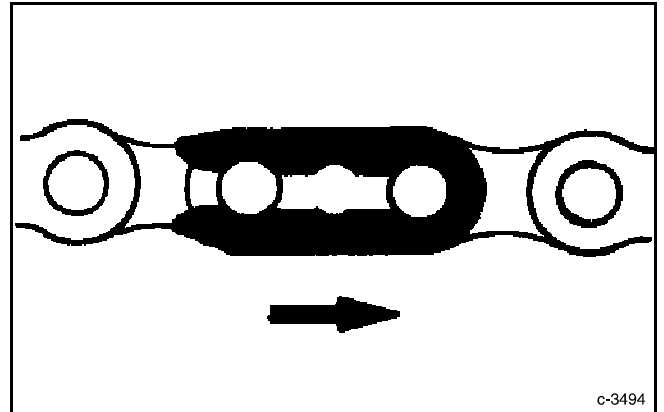


**FIG. 237**

**FIG. 267:** Remove spring clip from chain connector, then remove side bar and connecting link and remove chain from drive sprocket.

*NOTE: Inspect and service chain referring to "LUBRICATION and MAINTENANCE"..."Care of Roller Chains" and "Roller Chain Do Nots" sections in this section of manual.*

Chain idler can now be removed from corn head end panel.

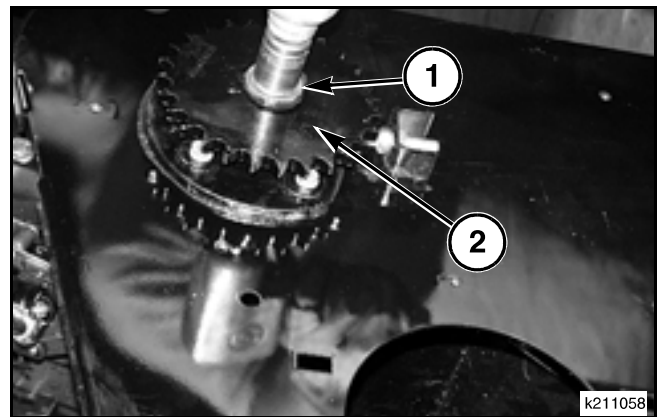


**FIG. 267**

**FIG. 268:** Clean grease from area, then remove 5/8-11 X 1-1/4 inch capscrew, lock washer, and flat washer (1) securing drive sprocket (2) to Left Hand drive shaft.

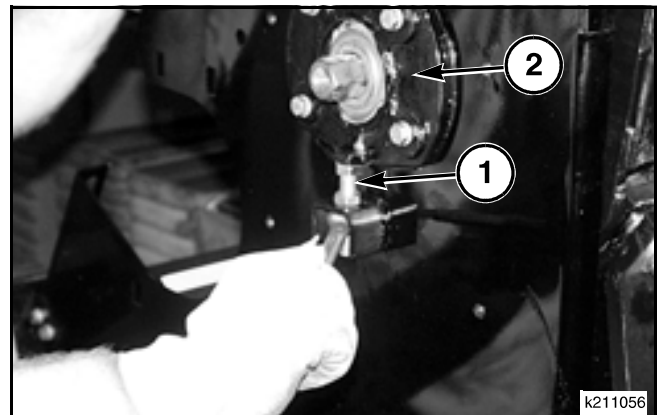
*NOTE: Cavity under flat washer has been sealed with RTV. Clean excess RTV from parts before assembly.*

Using a suitable puller, pull sprocket (2) from Left Hand end of shaft.



**FIG. 268**

**FIG. 269:** Loosen jam nuts on 1/2-13 X 2-1/2 inch capscrew (1) and back head of bolt away from bearing housing (2).



**FIG. 269**

**Assembly**

**FIG. 295:** Walterscheid Torque Limiter

Callouts for FIG.

1. **Housing**
2. **Hub**
3. **Cam**
4. **Inner and Outer Spring**
5. **Grease Fittings**
6. **Seal Ring**
7. **Support Ring**
8. **Retainer Ring**

The following steps should be used to assemble the limiter:

1. Before assembly, grease cams, springs, and pin bores.
2. Use large hose clamp to depress the row of cams (3) and springs (4) for assembly into housing (1).

*NOTE: Use the same number of inner springs and outer springs in each row as noted during disassembly.*

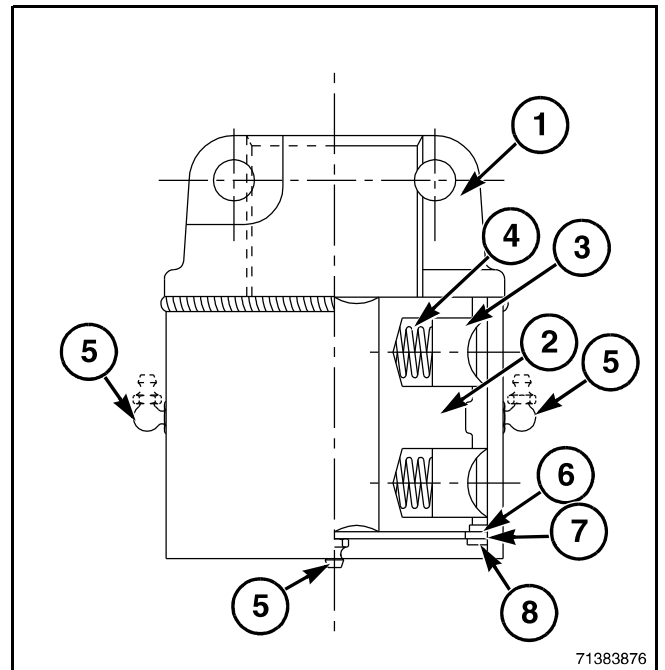
3. Insert hub (2) into housing (1) and with a block of wood to protect the hub from damage, hammer the hub with pins depressed into housing.
4. Replace sealing ring (6), support ring (7), and retaining ring (8).

*NOTE: Be sure sealing ring is properly seated.*

5. Grease assembly and rotate hub, if possible, to insure it functions properly.

Housing to be packed full of grease.

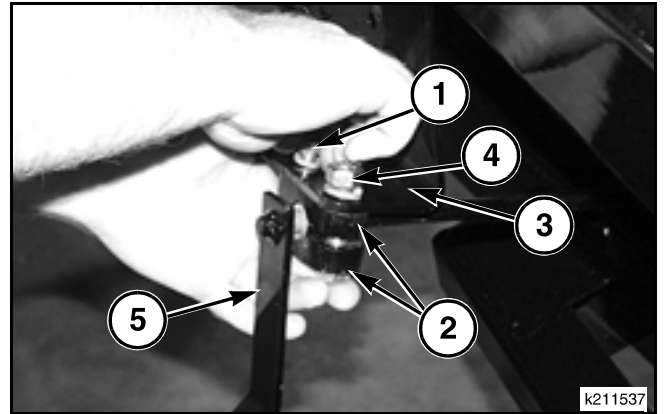
*NOTE: Cam cavities to have grease film only, not packed full.*



**FIG. 295**

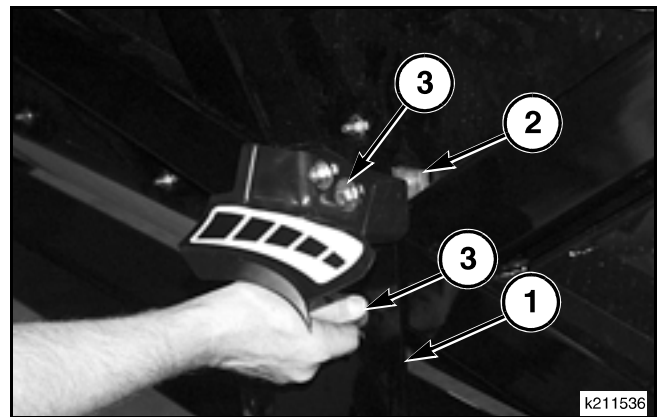
**FIG. 324:** Remove 3/8-16 X 2-1/4 inch capscrew with lock washer and hex nut (1) securing 5/8 inch outside diameter spacer between the two half clamps (2) to pointer plate (3).

Remove the remaining 1/2-13 X 2-1/4 inch capscrew with lock washer and hex nut (4). Remove clamps (2) securing point shaft assembly (5) and point shaft from out the back of the corn head.



**FIG. 324**

**FIG. 325:** Pointer plate (1) is retained to corn head back cross brace using two 3/8-16 X 2-3/4 inch capscrews (3) with lock washers and two 7/16 inch flat washers threaded into a loose mount strap (2) placed in front of cross brace.



**FIG. 325**

## SERVICE - FRAME GROUP

### Conveyor

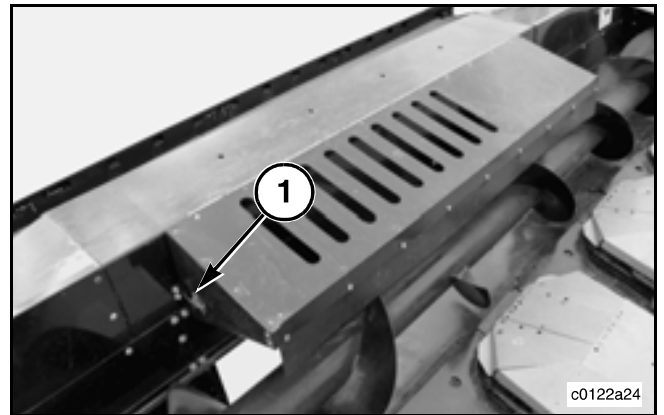
#### Removal

**FIG. 1:** Lower Corn Head until fully supported on the ground.



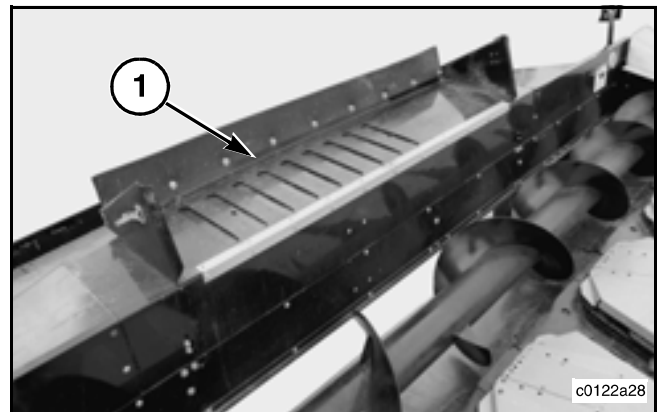
**FIG. 1**

**FIG. 2:** Release over center spring clamps (1) securing hood if equipped.



**FIG. 2**

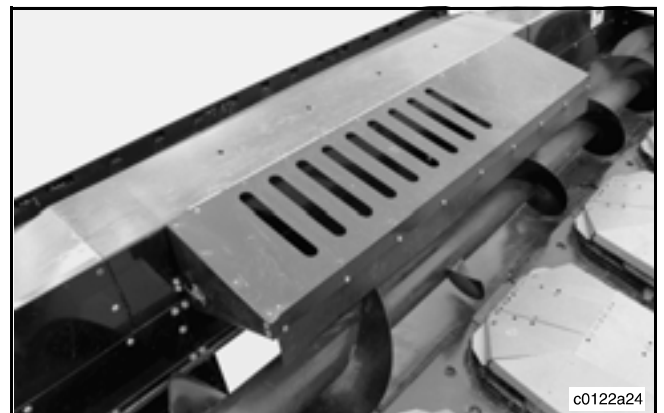
**FIG. 3:** Raise hood (1) and lay on top of truss. Remove the eleven 5/16-18 X 5/8 inch self tapping screws securing hood hinge to face of center truss. Remove hood assembly from Corn Head.



**FIG. 3**

#### Installation

**FIG. 4:** For a first time installation of the Conveyor Hood Package to reduce loss of cobs over front of Corn Head, use the following procedure.



**FIG. 4**

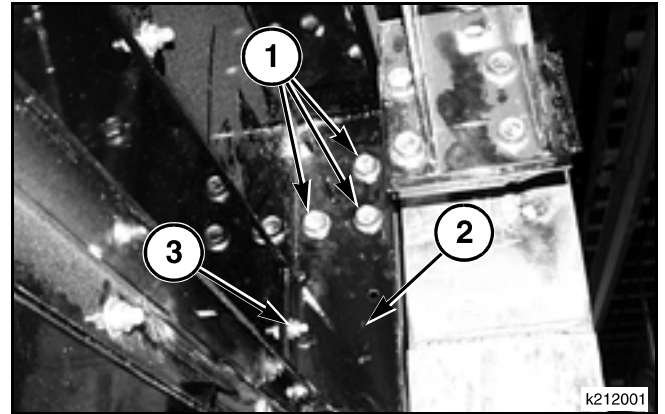
## SERVICE - FRAME GROUP

**FIGS. 34–35:** Remove the three 1/2-13 X 1.0 inch capscrews (1) with lock washers and hex nuts securing top of support weldment (2) to bracket welded to inside upper hopper frame.

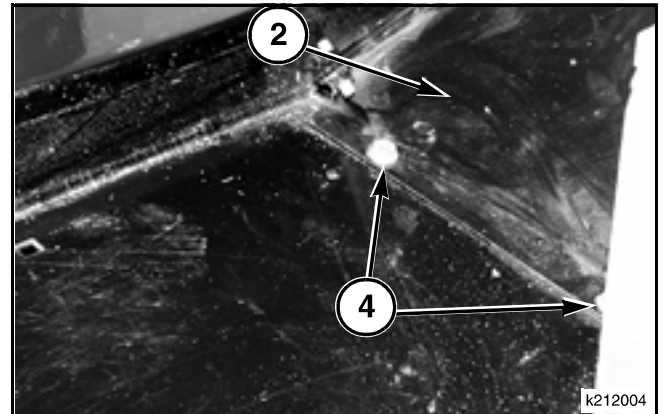
Remove the 5/16-18 X 3/4 inch short neck carriage bolt with flange nut (3) securing support (2) to center conveyor back.

Remove the two 5/16-18 X 5/8 inch hex flange head tapping screws (4) securing bottom of support (2) to hopper bottom.

Remove bottom extension support weldment (2) from hopper opening.



**FIG. 34**



**FIG. 35**

### Installation

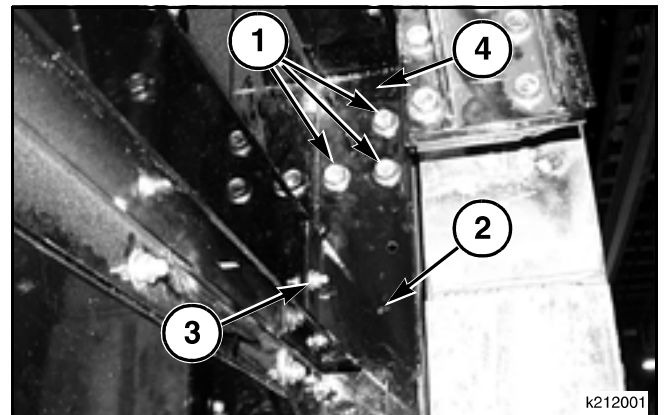
**FIGS. 36–37:** The Transverse Combine Corn Head requires a Left Hand inner conveyor bottom extension with the combine's 736.6 mm (29 inch) wide feeder house.

Place bottom extension support weldment (2) into hopper opening to the Left of the support bracket (4) welded to inside upper hopper frame.

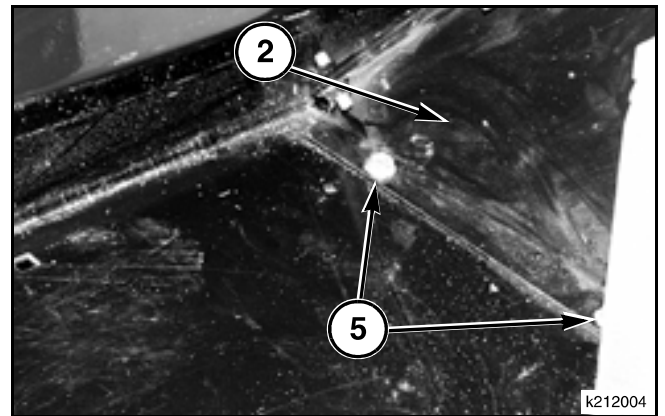
Loosely install the three 1/2-13 X 1.0 inch capscrews (1) with lock washers and hex nuts securing top of support weldment (2) to bracket welded to inside upper hopper frame.

Loosely install the 5/16-18 X 3/4 inch short neck carriage bolt with flange nut (3) securing support (2) to center conveyor back.

Loosely install the two 5/16-18 X 5/8 inch hex flange head tapping screws (5) securing bottom of support (2) to hopper bottom.



**FIG. 36**



**FIG. 37**

## Installation

**FIGS. 68–69: Center Conveyor (Back) Shield:** Position center conveyor shield (4) onto front of frame hopper weldment.

Install the two 5/16-18 X 1.0 inch capscrew with lock washer and flat washer (3) securing each upper end of shield to hopper post weldments.

*NOTE: On transverse combine model corn heads, lift shield (4) and place between inner conveyor extension (5) and hopper weldment shield support.*

Place center stripper angle (2) with extended flange downward onto lower edge of shield (4).

Install the 5/16-18 X 1.0 inch capscrew with lock washer and flat washer (3) securing each end of angle (2) and center conveyor shield (4) to hopper post weldment.

With both ends of the center conveyor stripper angle (2) now properly located, insert the 5/16-18 X 3/4 inch short neck carriage bolts securing conveyor stripper to center conveyor shield (4).

At the backside of the head, using 5/16-18 inch flange nuts (1), secure the 5/16-18 X 3/4 inch carriage bolts.

Securely tighten all conveyor stripper angle hardware.

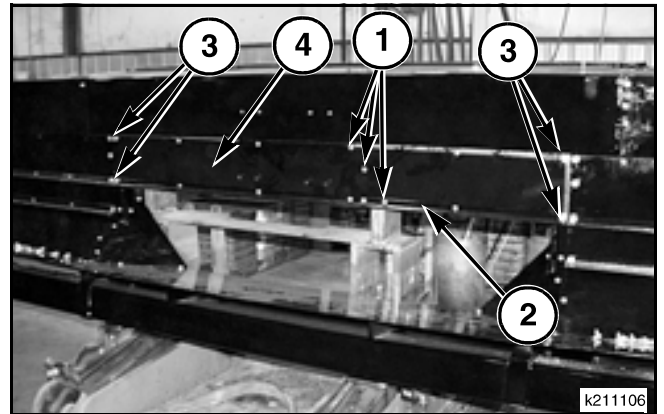


FIG. 68

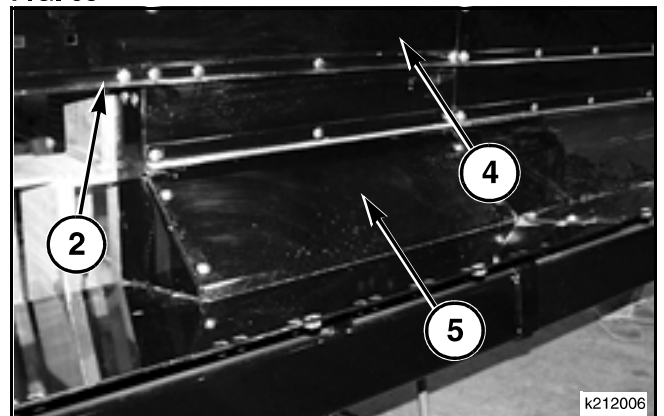


FIG. 69

**FIGS. 70–71: Right and or Left Hand Conveyor (Back) Extension:** Lift conveyor (back) extension (1) with notch in end to the outside. Place extension between the upper edge of conveyor bottom (2) and frame upper truss and extension brace (3) and fender hinge assembly (4) at outer end of truss.

*NOTE: On 12-Row 20 and 22 inch models, the fender hinge assembly has been removed.*

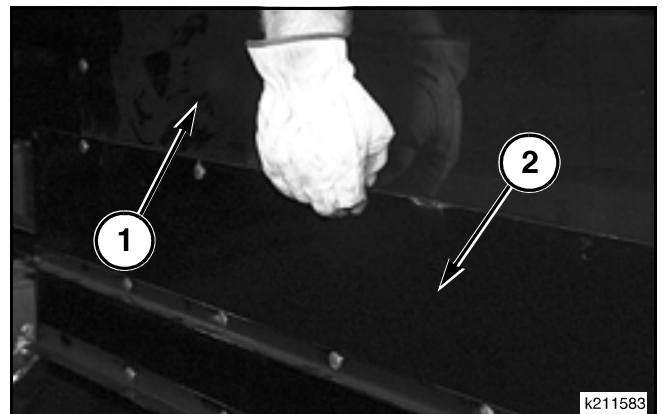


FIG. 70

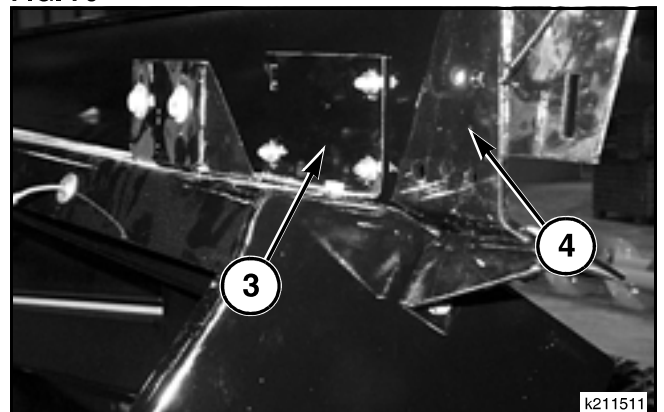


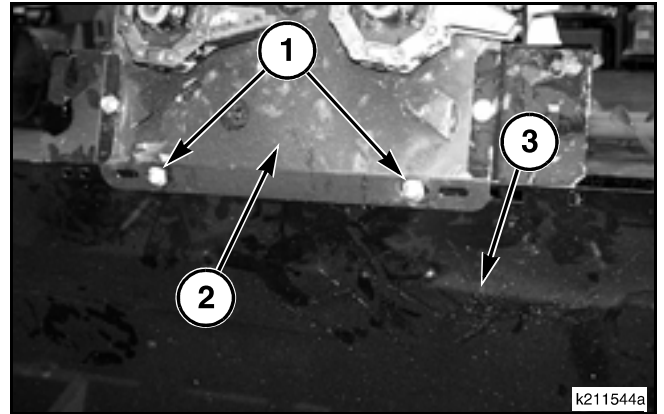
FIG. 71

## SERVICE - FRAME GROUP

**FIG. 104:** Install the two 5/16-18 X 7/8 inch T40 torx head tapping screws (1) with lock washers and flat washers securing each row unit cover (2) to conveyor bottom (3).

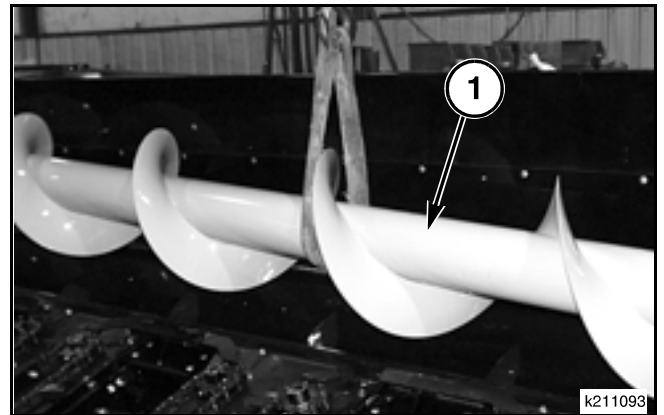
Securely tighten all hardware securing conveyor bottom.

Repeat the procedure for the opposite side.



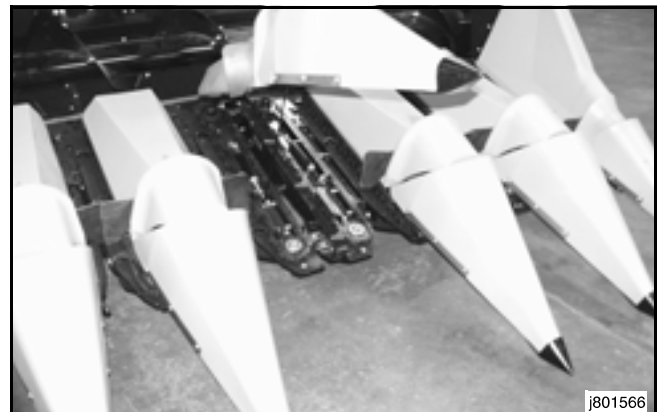
**FIG. 104**

**FIG. 105:** Install conveyor (1) following the procedure found in "SERVICE - GENERAL"... "Spiral Conveyor"... "Installation" section in this section of the manual.



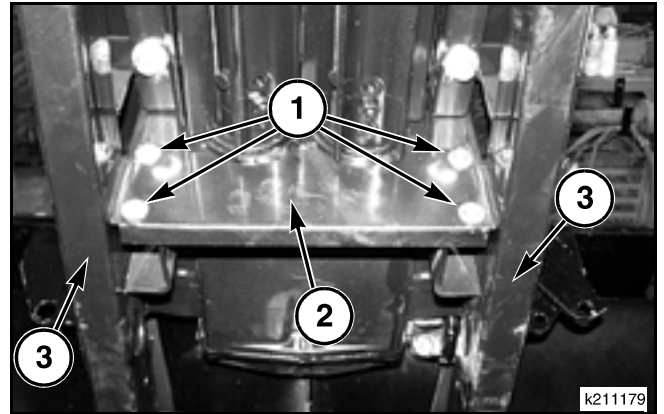
**FIG. 105**

**FIG. 106:** If it was necessary to remove the inner gathering sheets, install gathering sheets following the procedure found in "SERVICE - GENERAL"... "Inner Gathering Sheets"... "Installation" section in this section of the manual.



**FIG. 106**

**FIG. 22:** From under the front side of the snapping rolls, remove four 5/16-18 X 3/4 inch capscrews, lock washers and flat washers (1) securing snap roll shield (2) to Left Hand and Right Hand frame assembly (3).



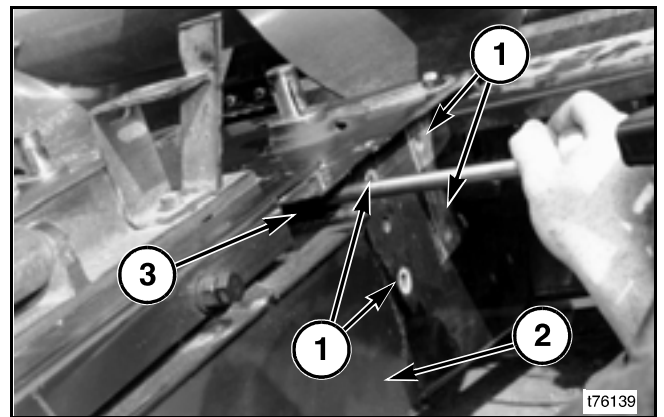
**FIG. 22**

**FIGS. 23–24:** Remove the four 1/2-13 X 1.0 inch capscrews, lock washers, and flat washers (1) securing gearbox to Left Hand side frame (2).

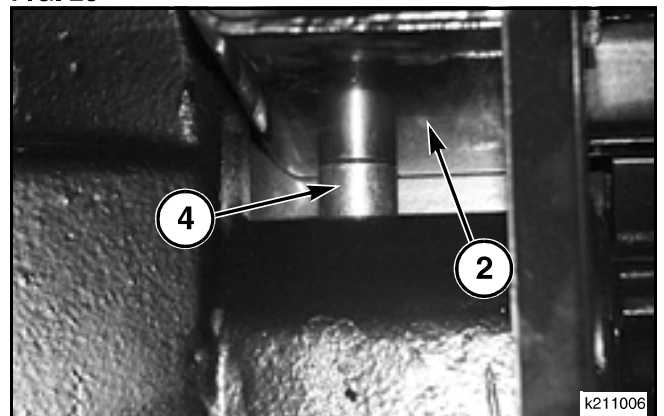
*NOTE: The rear two 1/2-13 X 1.0 inch capscrews (1) may have been removed while removing inner gather sheet rear hinge mounting brackets or during removal of optional electric adjust stripper plate lever.*

Remove remaining 1/2-13 X 2-1/2 inch capscrew with lock washer (3) holding Left Hand frame unit (2) to gearbox. Capscrew is located under top cover as shown.

*NOTE: A spacer (4) located between frame unit and gearbox will fall out. Make sure this spacer is installed during assembly.*



**FIG. 23**



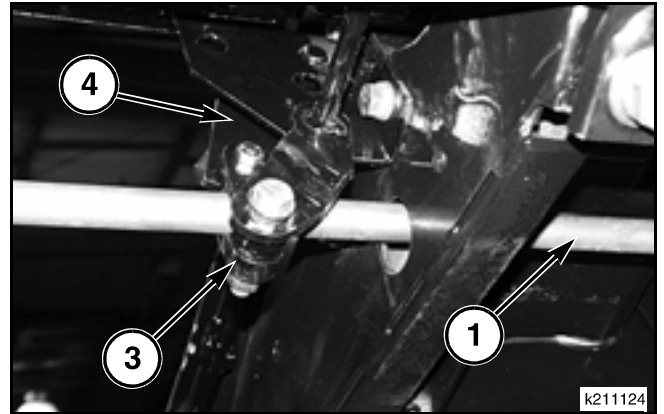
**FIG. 24**

**FIGS. 54–55:** If Corn Head was equipped with the optional adjustable stripper plates, install the electric actuator (2), stripper plate lever assembly (4), control shaft (1), and control shaft half clamps (3) following the procedure found in "SERVICE - GENERAL"... "Adjustable Stripper Plates"... "Installation" section in this section of the manual.

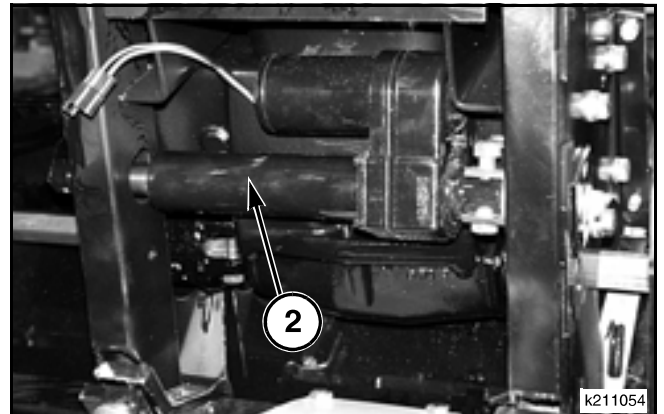
*NOTE: For 4 and 6-Row headers, install control shaft (1) where gearboxes were serviced except the far Left Hand with the electric actuator.*

For 8 and 12-Row headers, install Right Hand control shaft (1) where gearboxes were serviced for rows right of center and both control shafts where gearboxes were serviced for rows left of center except the far Left Hand with the electric actuator.

*NOTE: If the complete row unit is being installed, it is not necessary to install "Stripper Plate Lever Assembly" since the lever assembly would have been installed during the row unit repair.*

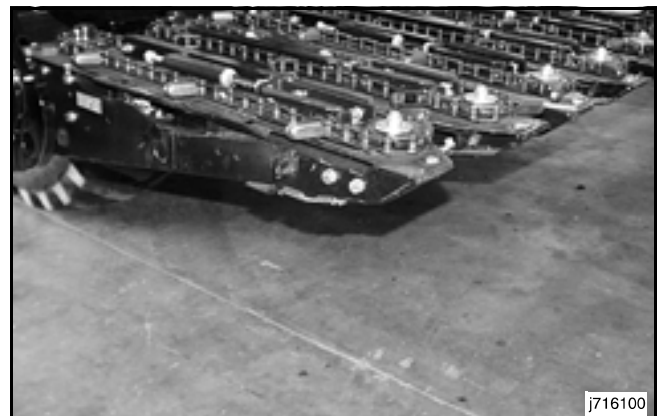


**FIG. 54**



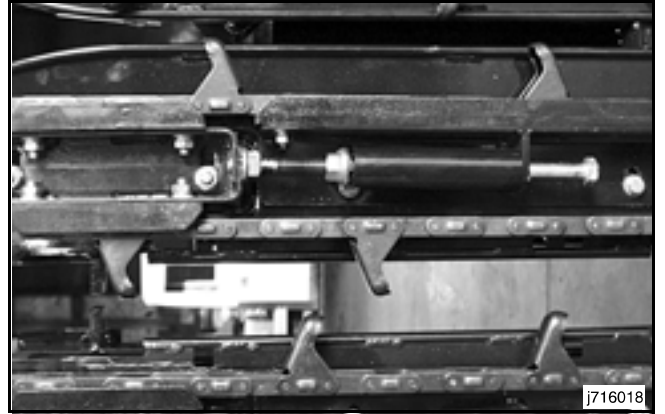
**FIG. 55**

**FIG. 56:** Install divider points and gathering sheets next to the row unit installed or repaired following the procedure found in "SERVICE - GENERAL"... "Inner Gathering Sheets"... "Fenders (Outer Gathering Sheets)"... "Installation" sections in this section of the manual.



**FIG. 56**

**FIG. 90:** For adjustment of row unit after installation, refer to "ADJUSTMENTS"... "Row Unit"... "Gather Chain"... "Stripper Plates"... "Snapping Rolls" and "Grass Knives" sections in this section of the manual.

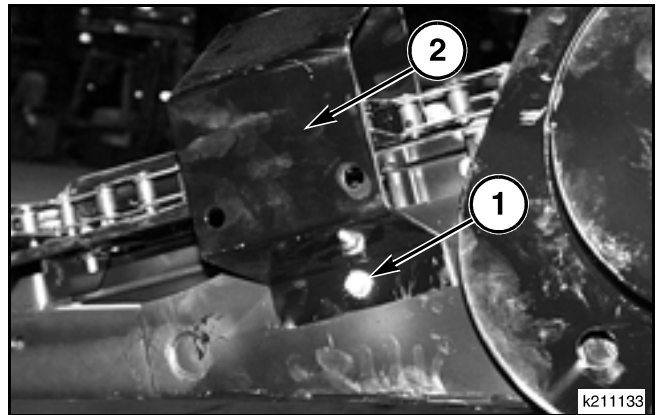


**FIG. 90**

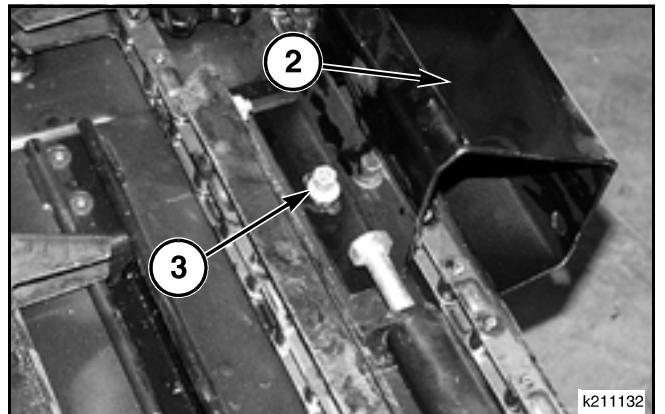
**FIGS. 91–92:** If Right Hand or Left Hand fender mid mount bracket (2) was removed, use existing 3/8-16 X 1-1/2 inch row unit hardware (3) to secure top flange of fender bracket (2) to top of row unit rear chain guide.

Install 3/8-16 X 1.0 in hex flange capscrew (1) and hex flange top lock nut securing bracket to side of row unit frame.

Tighten hardware securely.



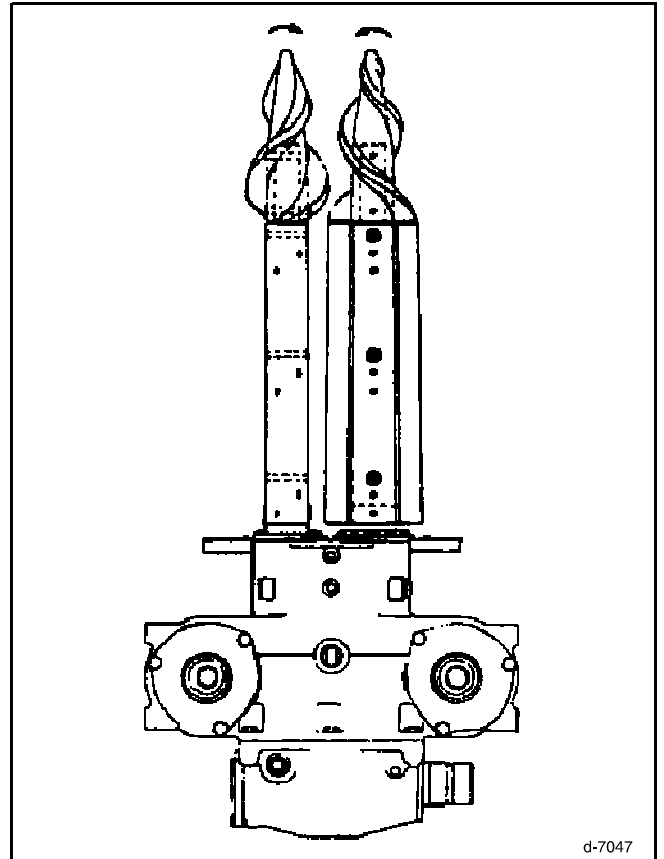
**FIG. 91**



**FIG. 92**

**FIG. 126:** Gearbox is assembled correctly when input shaft is rotated clockwise facing Right Hand end of input (hollow) shaft and:

- The snapping roll shafts turn in opposite directions with Left Hand shaft turning clockwise facing rear of snapping roll shaft.
- The gather shafts turn in opposite directions with Left Hand shaft turning clockwise facing top of shaft.
- Box should rotate freely and not bind. Input shaft must rotate at not more than 7.9 Nm (70 in.-lbs.) torque.
- Snapping roll shafts must be properly indexed with front roll point groove pin located at 90 degrees to each other.
- Input (hollow) shaft tapered bearings must be adjusted to free turning to no more than 0.127 mm (0.005 inch) endplay.



**FIG. 126**

**FIG. 127:** Install gearbox onto corn head following procedure covered in "SERVICE - ROW UNIT"... "Unit Frame and Gearbox"... "Installation" section in this section of manual.

*NOTE: To fill and check grease in gearbox, refer to "GENERAL INFORMATION"... "Lubrication and Maintenance"... "Lubrication" section in this section of the manual.*

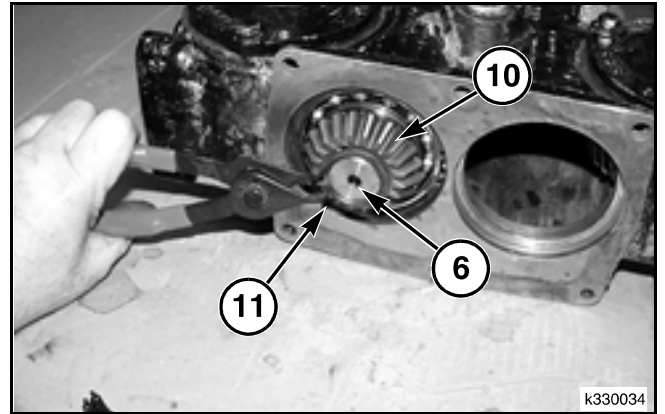


**FIG. 127**

**FIG. 157:** Retain pinion gear (10) to snapping roll shaft (6) using snap ring pliers to install external snap ring (11) into groove in shaft.

Ensure snap ring is firmly seated into groove.

If both snapping roll shafts were removed, repeat above procedure for second shaft.



**FIG. 157**

CLICK HERE TO **DOWNLOAD** THE COMPLETE MANUAL

- Thank you very much for reading the preview of the manual.
- You can download the complete manual from: [www.heydownloads.com](http://www.heydownloads.com) by clicking the link below



- Please note: If there is no response to CLICKING the link, please download this PDF first and then click on it.

CLICK HERE TO **DOWNLOAD** THE COMPLETE MANUAL