

# **Workshop Manual**

**Group 21-26**

I
3(0)

**TD520GE, TAD520GE, TD520VE, TAD520VE  
TD720GE, TAD720GE, TD720VE, TAD720VE  
TAD721GE, TAD721VE, TAD722GE, TAD722VE**

CLICK HERE TO **DOWNLOAD** THE COMPLETE MANUAL

- Thank you very much for reading the preview of the manual.
- You can download the complete manual from: [www.heydownloads.com](http://www.heydownloads.com) by clicking the link below



- Please note: If there is no response to CLICKING the link, please download this PDF first and then click on it.

CLICK HERE TO **DOWNLOAD** THE COMPLETE MANUAL

## Special tools

The following special tools are used when working on the engine. You can order them from AB Volvo Penta using the numbers shown.

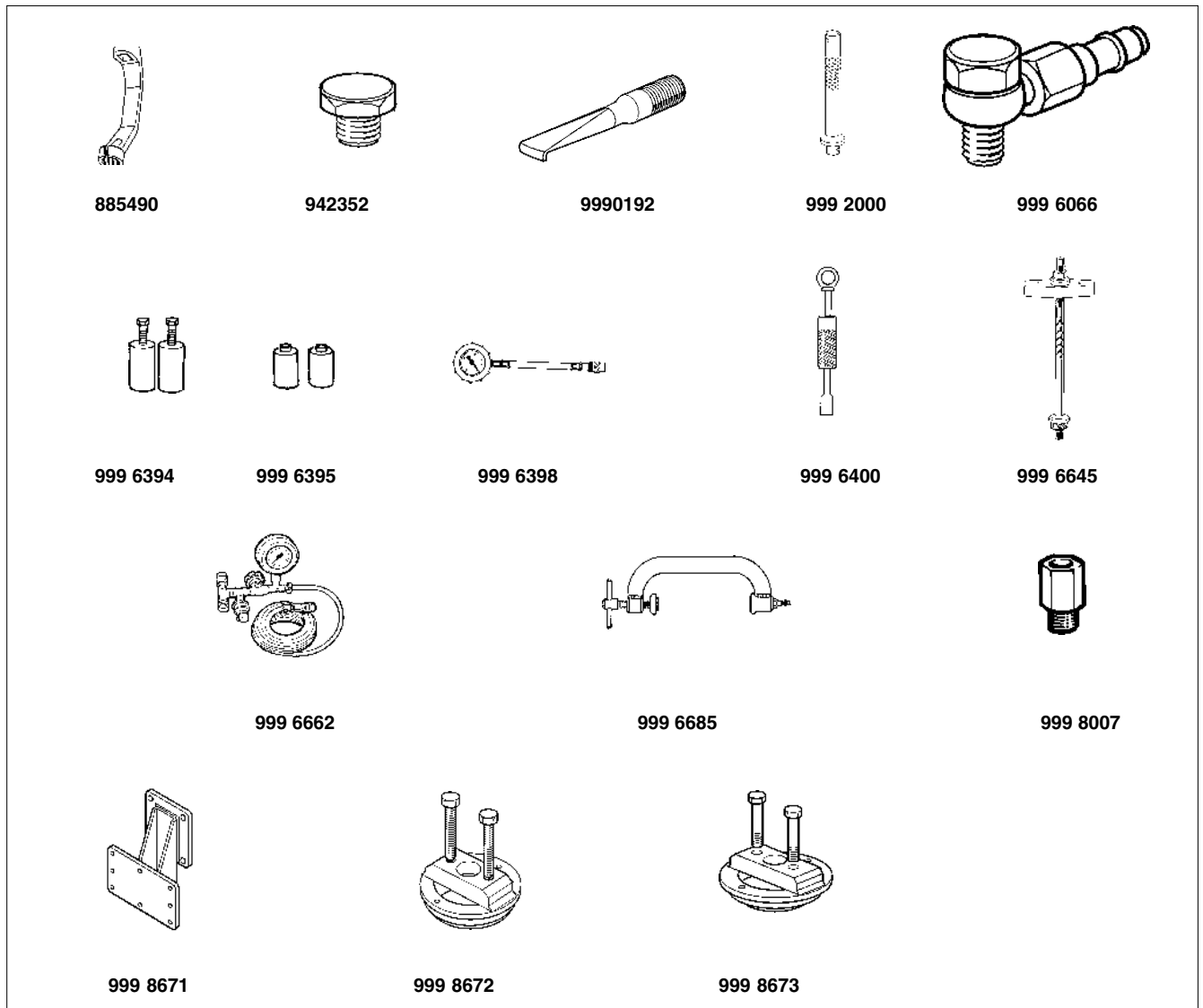

Tool	Name, use	Tool	Name, use
885490	17 mm wrench, delivery pipe	999 6645	Extractor, cylinder liners
942352	Plug, oil cooler	999 6662	Pressure-testing equipment for oil cooler
9990192	Extractor, crankshaft seal, used with 999 6400	999 6685	Clamp for oil cooler
999 2000	Standard shaft, drifts	999 8007	Socket for injector removal, together with 999 6400
999 6066	Nipple, used with manometer 999 6398	999 8671	Engine fixture for aggregate stand
999 6394	Support, for 999 6645	999 8672	Fitting/Removal tool, rear crankshaft seal
999 6395	Support, for 999 6645	999 8673	Fitting/Removal tool, front crankshaft seal
999 6398	Manometer		
999 6400	Slide hammer, for injectors and reduction valve		

## Cooling system

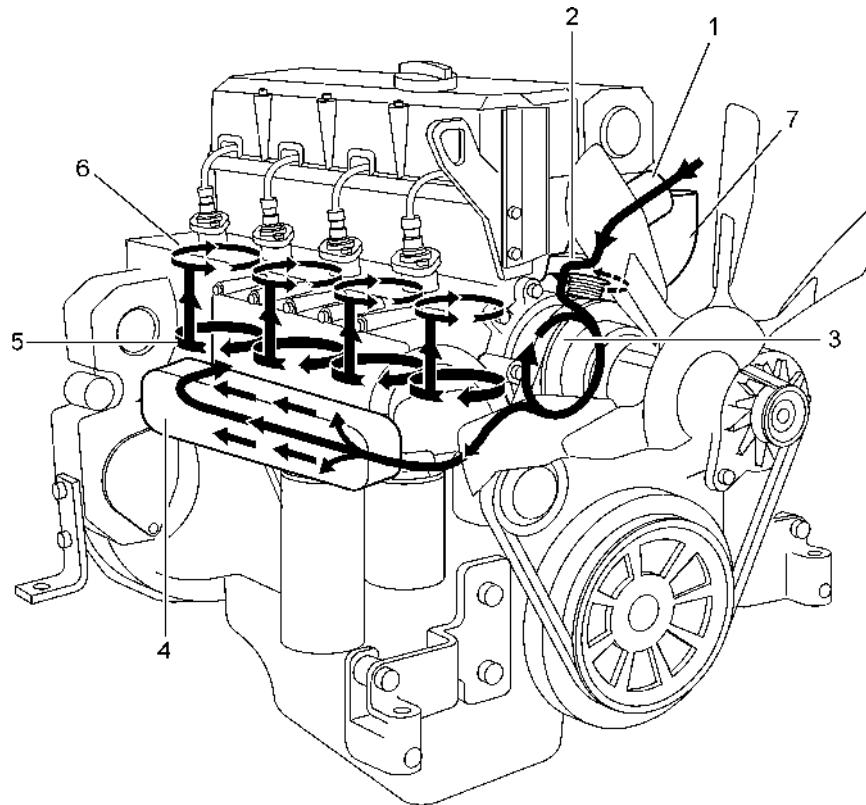

- 1 Coolant connection (inlet)
- 2 Thermostat housing
- 3 Coolant pump
- 4 Lubricating oil cooler
- 5 Cylinder cooling
- 6 Cylinder head cooling
- 7 Coolant connection (outlet)

**Table 2**

Theoretical thickness "T <sub>s</sub> " (mm)	Shim thickness "S <sub>s</sub> " (mm)	Theoretical thickness "T <sub>s</sub> " (mm)	Shim thickness "S <sub>s</sub> " (mm)
0.95–1.049	1.0	3.05–3.149	3.1
1.05–1.149	1.1	3.15–3.249	3.2
1.15–1.249	1.2	3.25–3.349	3.3
1.25–1.349	1.3	3.35–3.449	3.4
1.35–1.449	1.4	3.45–3.549	3.5
1.45–1.549	1.5	3.55–3.649	3.6
1.55–1.649	1.6	3.65–3.749	3.7
1.65–1.749	1.7	3.75–3.850	3.8
1.75–1.849	1.8	3.85–3.949	3.9
1.85–1.949	1.9	3.95–4.049	4.0
1.95–2.049	2.0	4.05–4.149	4.1
2.05–2.149	2.1	4.15–4.249	4.2
2.15–2.249	2.2	4.25–4.349	4.3
2.25–2.349	2.3	4.35–4.449	4.4
2.35–2.449	2.4	4.45–4.549	4.5
2.45–2.549	2.5	4.55–4.649	4.6
2.55–2.649	2.6	4.65–4.749	4.7
2.65–2.749	2.7	4.75–4.849	4.8
2.75–2.849	2.8	4.85–4.949	4.9
2.85–2.949	2.9	4.95–5.049	5.0
2.95–3.049	3.0		

(100 mm = 3.937")

**Table 3**

E <sub>k</sub> (mm)	EP code	E <sub>k</sub> (mm)	EP code	E <sub>k</sub> (mm)	EP code	E <sub>k</sub> (mm)	EP code	E <sub>k</sub> (mm)	EP code
144.5		145.1		145.7	349	146.3	373	146.9	397
144.525		145.125		145.725	350	146.325	374	146.925	398
144.55		145.15		145.75	351	146.35	375	146.95	399
144.575		145.175		145.775	352	146.375	376	146.975	400
144.6		145.2		145.8	353	146.4	377	147.0	401
144.625		145.225		145.825	354	146.425	378	147.025	
144.65		145.25		145.85	355	146.45	379	147.05	
144.675		145.275		145.875	356	146.475	380	147.075	
144.7		145.3		145.9	357	146.5	381	147.1	
144.725		145.325		145.925	358	146.525	382	147.125	
144.75		145.35	335	145.95	359	146.55	383	147.15	
144.775		145.375	336	145.975	360	146.575	384	147.175	
144.8		145.4	337	146.0	361	146.6	385	147.2	
144.825		145.425	338	146.025	362	146.625	386	147.225	
144.85		145.45	339	146.05	363	146.65	387	147.25	
144.875		145.475	340	146.075	364	146.675	388	147.275	
144.9		145.5	341	146.1	365	146.7	389	147.3	
144.925		145.525	342	146.125	366	146.725	390	147.325	
144.95		145.55	343	146.15	367	146.75	391	147.35	
144.975		145.575	344	146.175	368	146.775	392	147.375	
145.0		145.6	345	146.2	369	146.8	393	147.4	
145.025		145.625	346	146.225	370	146.825	394	147.425	
145.05		145.65	347	146.25	371	146.85	395	147.45	
145.075		145.675	348	146.275	372	146.875	396	147.475	

(100 mm = 3.937")

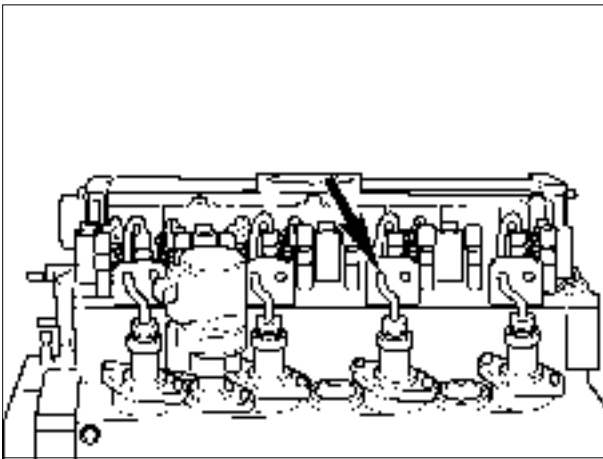

12. Remove the delivery pipes, complete with the rubber seals.

**NOTE!** Cover the injector and injector pump openings.

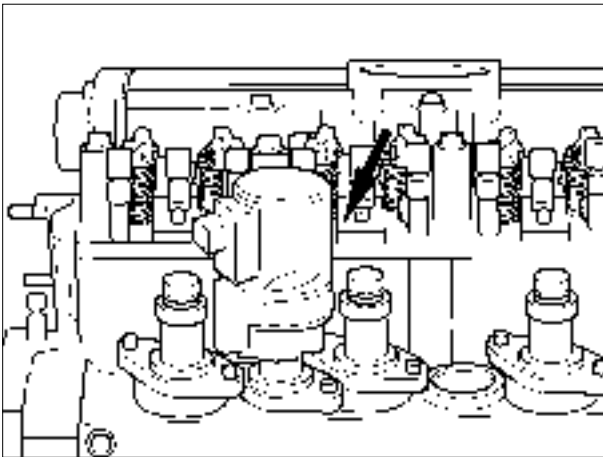

13. Remove the stop solenoid (alternatively the plug if the governor is electronic).

**NOTE!** Be careful not to damage the control rod. Install 999 8682 to keep the control rod in the protected "stop" position.

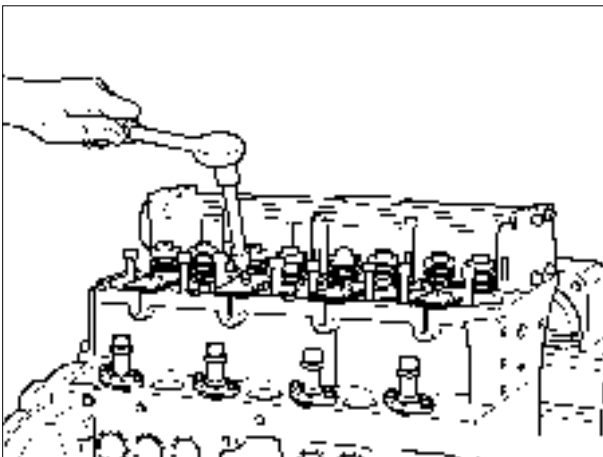

14. Remove the injectors. Use a Torx socket E 10.  
Use puller 999 6400 together with socket 999 8007 if any injector is stuck in the cylinder head.

**NOTE!** To prevent dirt and water coming in the injector hole, make sure to clean well around the injector before removing it.

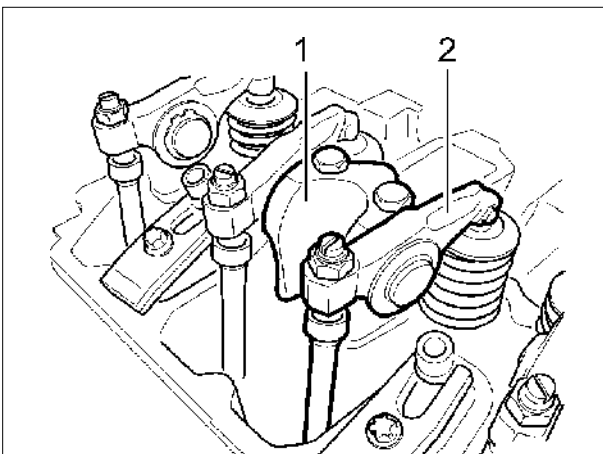

15. Mark up the rocker arm brackets (1) and remove them together with the rocker arms (2).

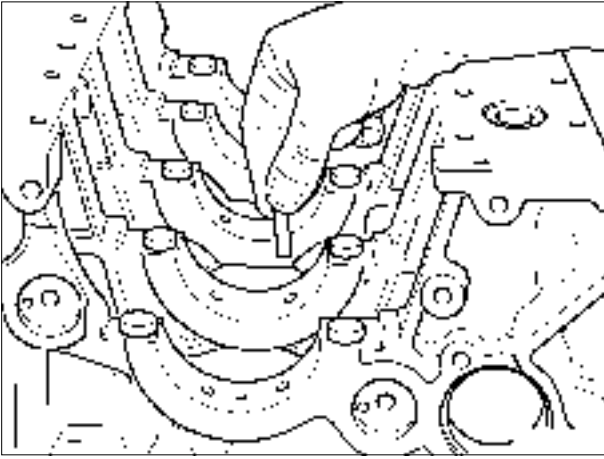
**Piston cooling nozzles**

4. Check that the oilways are not blocked. Fit the piston cooling nozzles in the correct position in the engine block. Press the piston cooling nozzles in as far as they will go.

**Cams/camshaft**

5. Insert the valve tappets (lightly oiled).

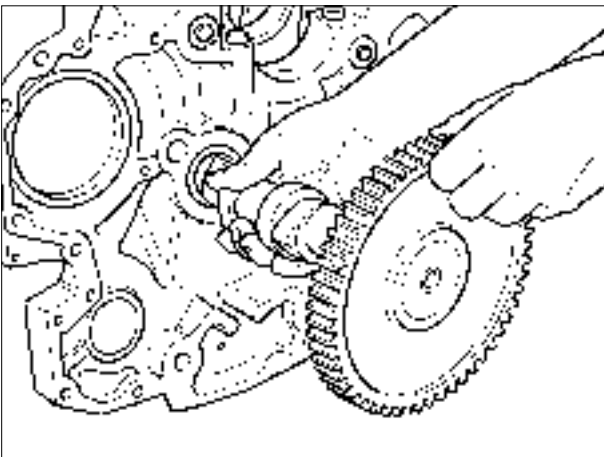

6. Fit the camshaft.

**NOTE!** Be careful when fitting the camshaft to prevent damaging the bearings.

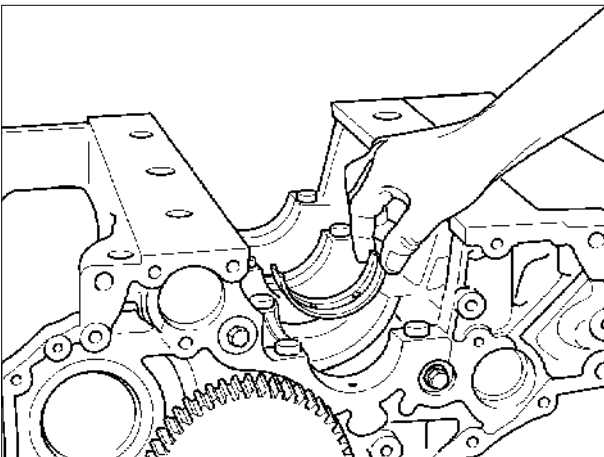

7. Fit the main bearing shells into the engine block.

## Determining the injection angle, shim thickness, and fitting of injection pumps

**NOTE!** The injection angle and type of camshaft is stated on the engine identification plate.

To follow the procedure described below, is only required if the engine block, camshaft or a roller tappet has been replaced.

**When fitting existing injection pumps see section "Injection pump installation" in this chapter.**

**When changing an injection pump only, see chapter "Changing injection pump".**

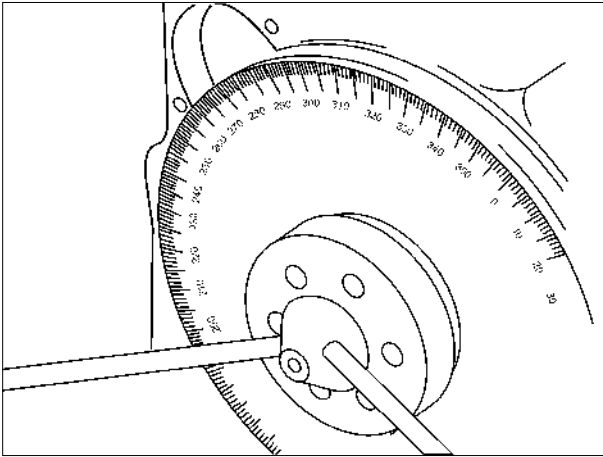

44. Fit the protractor (999 8679) to the flywheel flange on the crankshaft.

**NOTE!** Make sure that you tighten the screws so that there is no play.

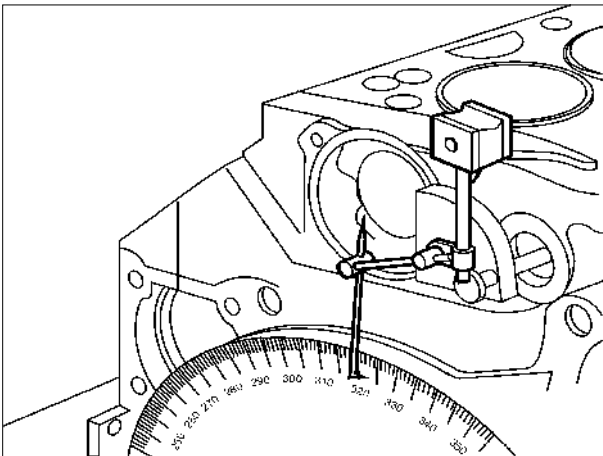

45. Attach a pointer.  
Use a magnetic stand.

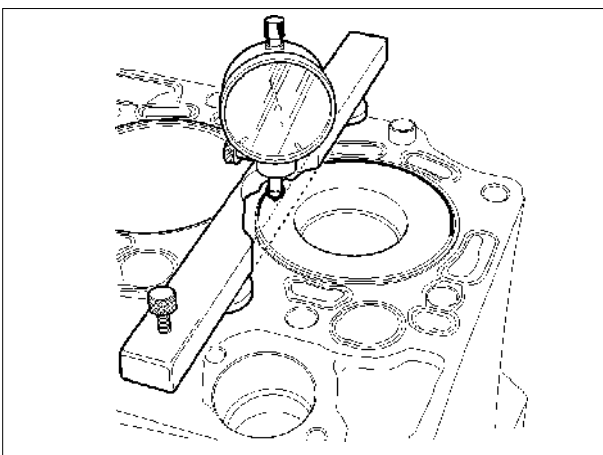

46. Position the measuring bar (999 8678) with spacers on the engine block over the piston belonging to the injection pump for which you are setting the timing.

Turn the crankshaft in the direction of engine rotation until the dial gauge has reached its turning point. Set the dial gauge to "0".

**⚠ IMPORTANT!** The dial gauge must be placed in the center of the gudgeon pin direction.

CLICK HERE TO **DOWNLOAD** THE COMPLETE MANUAL

- Thank you very much for reading the preview of the manual.
- You can download the complete manual from: [www.heydownloads.com](http://www.heydownloads.com) by clicking the link below



- Please note: If there is no response to CLICKING the link, please download this PDF first and then click on it.

CLICK HERE TO **DOWNLOAD** THE COMPLETE MANUAL

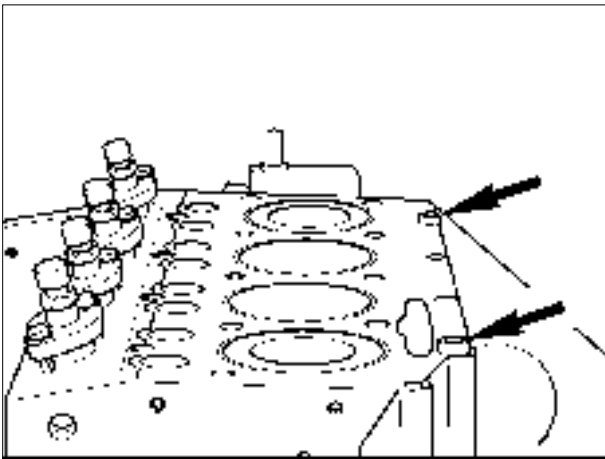

83. Position the cylinder head gasket correctly (with the numbers facing upwards and the marking holes towards the flywheel).

**NOTE!** The cylinder sealing surfaces must be clean and free of oil. Pay particular attention to the dowel sleeves.

**Cylinder head with valve gear**

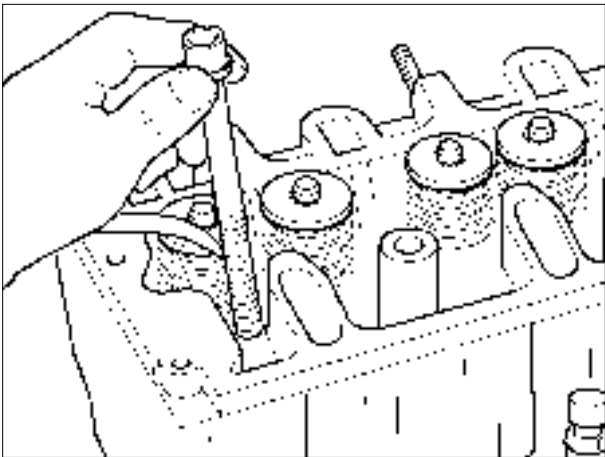

84. Fit the cylinder head. Oil the cylinder head bolts (but let the oil drip off) and screw them in finger tight.

**NOTE!** You can use the cylinder head bolts up to 5 times if you know how many times they have been used. (Make a punch mark for each of the following usages.)

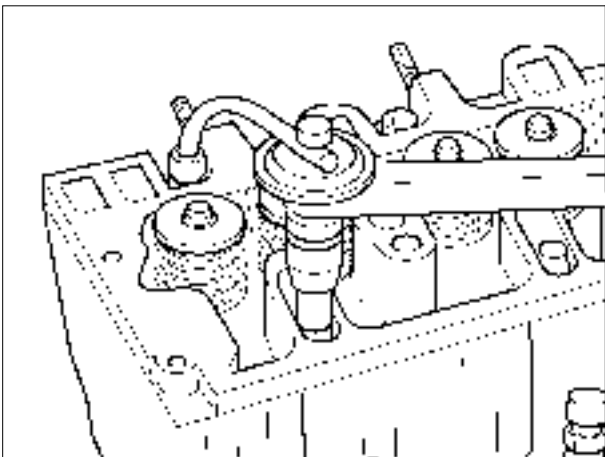

85. Tighten the cylinder head bolts as specified below:

**NOTE!** Follow the tightening sequence for the cylinder head, see "Tightening sequence for cylinder head screws".

Tighten the bolts in three stages:

- 1<sup>st</sup> stage: ..... **50 Nm** (37 lbf ft)
- 2<sup>nd</sup> stage: ..... **130 Nm** (96 lbf ft)
- 3<sup>d</sup> stage, tightening angle: ..... **90°**

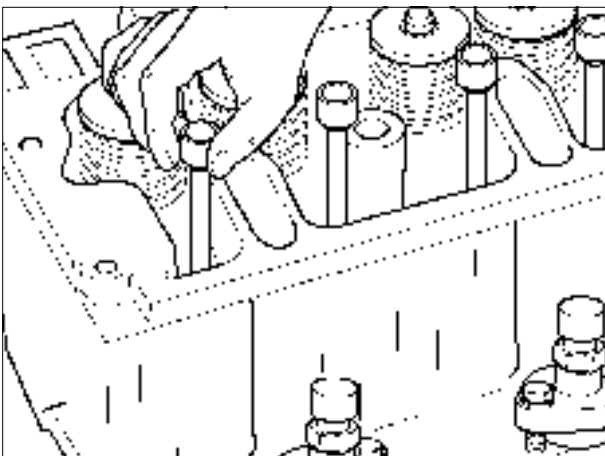

86. Insert the push rods, according to the mark up during disassembly.

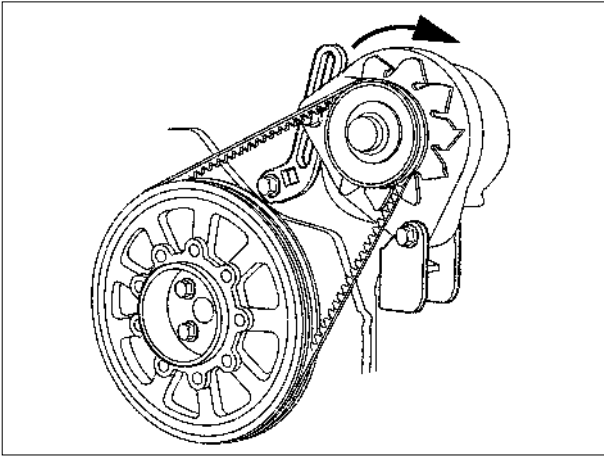

**Alternator**

128. Fit the alternator bracket and alternator.  
 Fit the V-belt.  
 Adjust the position of the alternator by pushing it in the direction of the arrow until you obtain the correct belt tension.  
 Tighten the screws to ..... **30 Nm** (22 lbf ft).

**NOTE!** The belt is correctly tensioned when you can press it down 10 mm (0.4") between the pulleys.

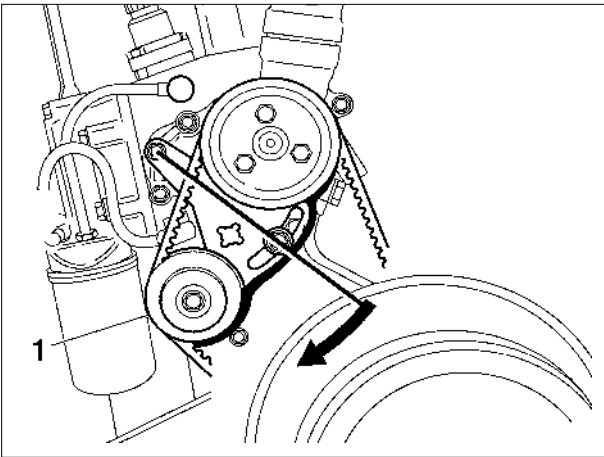

**129. Fit the belt and tension it.**

1. Push the fuel pump (1) in the direction of the arrow until you obtain the correct belt tension.\*
2. Tighten the screws to ..... **21 ±2 Nm** (15.5 ±1.5 lbf ft).

**\*NOTE!** The belt tension is correct when you can press them down 10 mm (0.4") midway between the pulleys.

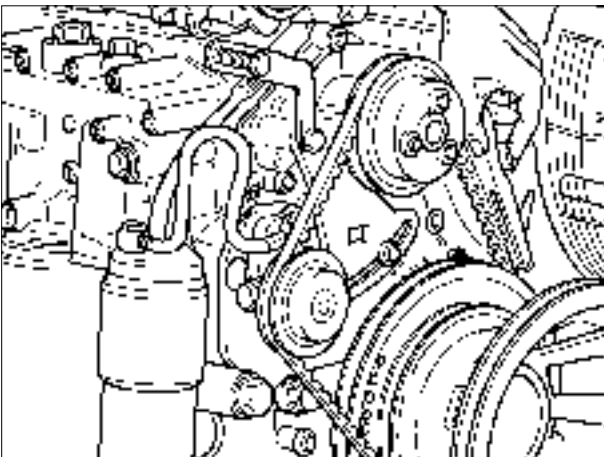

**Check the belt tension, coolant/fuel pump**

130. The belt is correctly tensioned when you can press it down **10 mm** (0.4") between the pulleys.

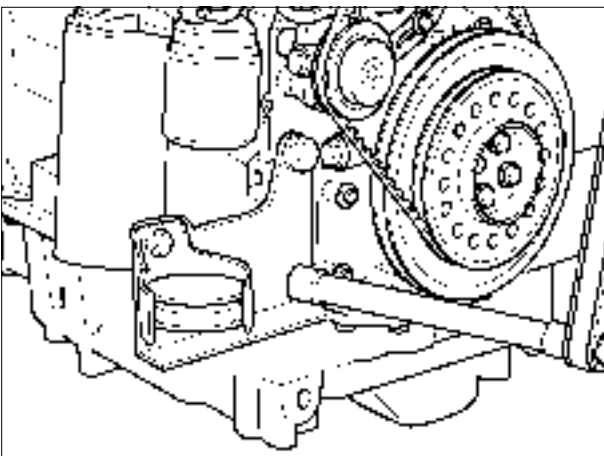

**Engine mounting**

131. Fit the engine mounting. Tighten to ..... **260 Nm** (192 lbf ft).

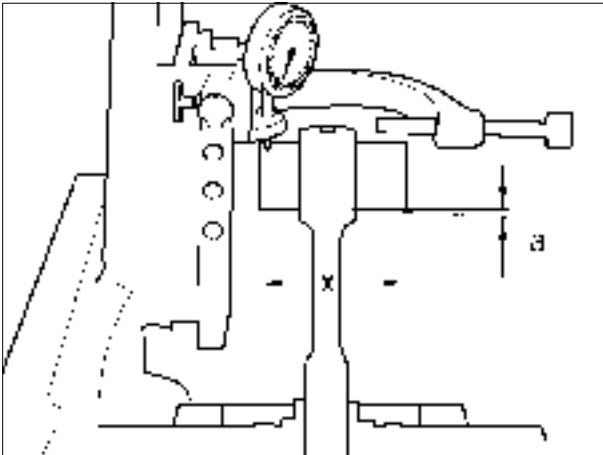

**If there is any reason to suspect a bent or twisted connecting rod, they should be checked on the connecting rod tester.**

**NOTE!** Check the connecting rods without bearing shells.

12. Use a gudgeon pin to measure the connecting rod for straightness.

Max. deviation  $a = 0.05 \text{ mm}$  (0.002") over a distance ( $x$ ) of 100 mm (3.9").

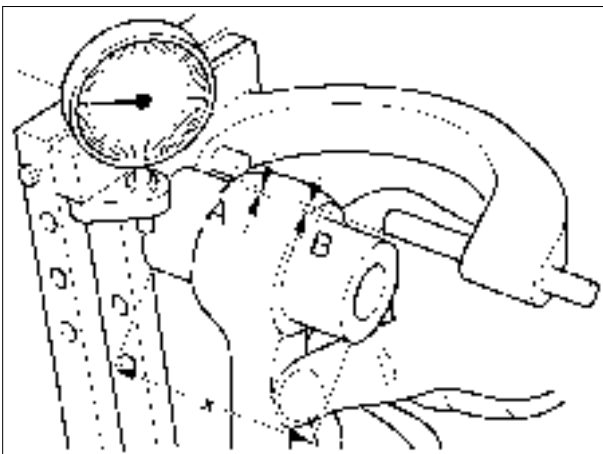

13. Use a gudgeon pin to measure the connecting rod for torsion.

Max. deviation  $a = 0.05 \text{ mm}$  (0.002") over a distance ( $x$ ) of 100 mm (3.9").



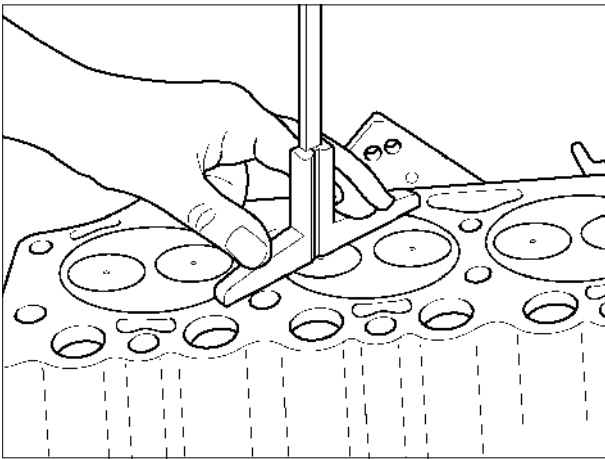

9. Measure the distance between the center of the valve head and the cylinder head mating surface.  
 Depth of valve in cylinder head:  
 Measurement between valve disc and cylinder head face:  
 Inlet/Exhaust ..... Max **1.5 mm** (0.06")

10. Measure the length of the valve spring using a sliding caliper and with the spring unloaded.

Unloaded length, standard  
**64.70 ±1.3 mm** (2.55" ±0.05")

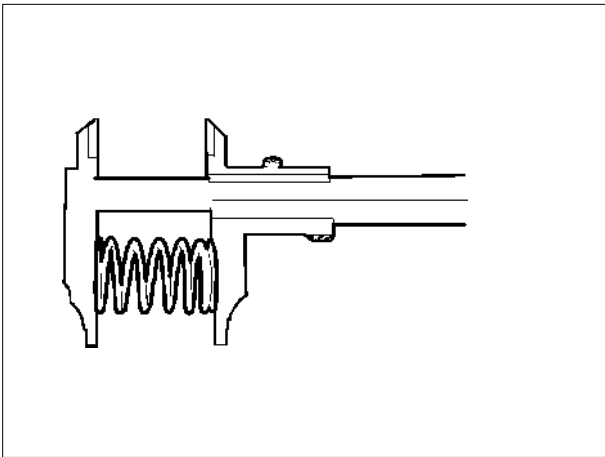

11. Use the grinding tool to grind the valves into their seats and correct the seat angle.

Valve seat angle	Inlet	Exhaust
	<b>30°</b>	<b>45°</b>
Valve seat width, maximum	Inlet	Exhaust
	<b>2.8 mm</b> (0.11")	<b>2.2 mm</b> (0.09")

**NOTE!** Measure the depth of the valve in the cylinder-head again after you have ground in the valves.

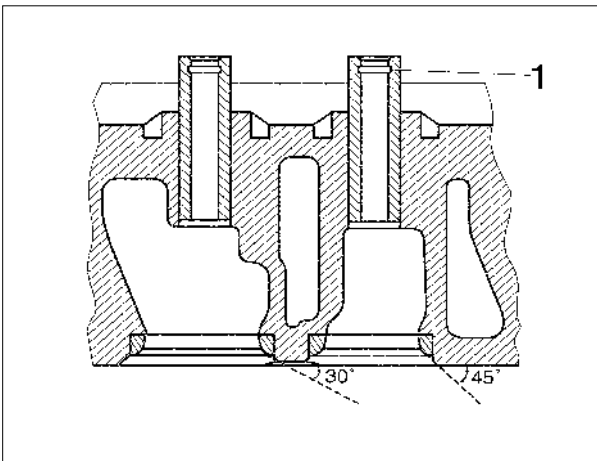

12. Insert the valve stem seal (1)

13. Fit the valves, valve springs and spring discs.

**NOTE!** Oil the stems of the inlet and exhaust valves. Push the valves in gently, with a slight twisting motion. The o-ring (1) is very thin and can easily be damaged.

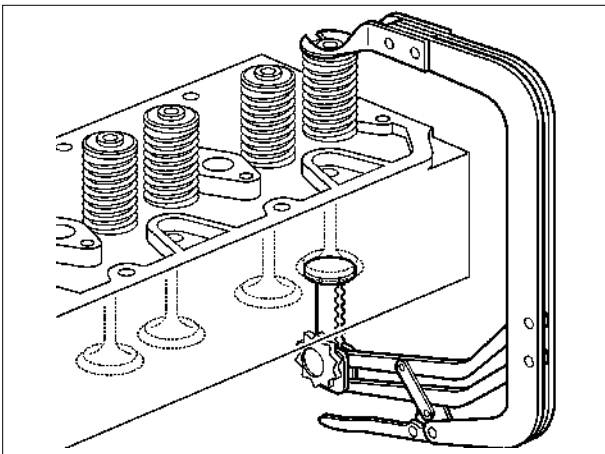

14. Use valve spring compressor 998 5468 for the valve springs. Insert the valve retainers.

# Valve clearance, checking/adjusting

(21403)

## Special tools:

Rotating tool, crankshaft ..... 999 8676

Cranking tool, flywheel ..... 999 8681

**NOTE!** The normal valve clearance is set when the engine is cold or has cooled down for at least half an hour.  
Oil temperature  $\leq 80^{\circ}\text{C}$  ( $176^{\circ}\text{F.}$ )

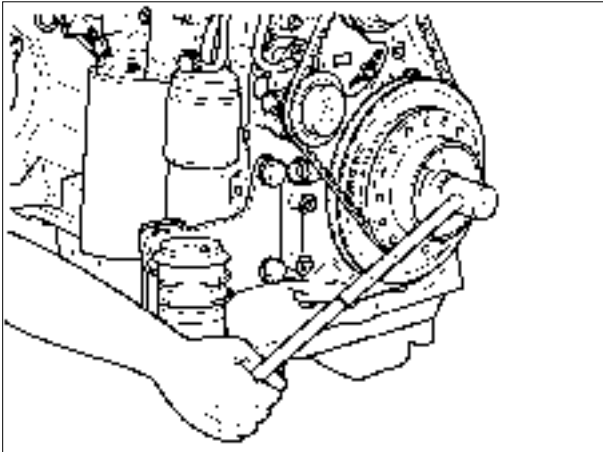

**NOTE!** The valve clearance should be at the highest permissible variation when the cylinder head gasket is changed and at the lowest permissible variation after 50 hours running.

1. Rotate the crankshaft until the valves for no. 1 cylinder overlap.

**NOTE!** The valves overlapping means: The exhaust valve is closing. The inlet valve is opening. Neither of the push rods can be turned in this position. (Number 1 cylinder is nearest the flywheel).

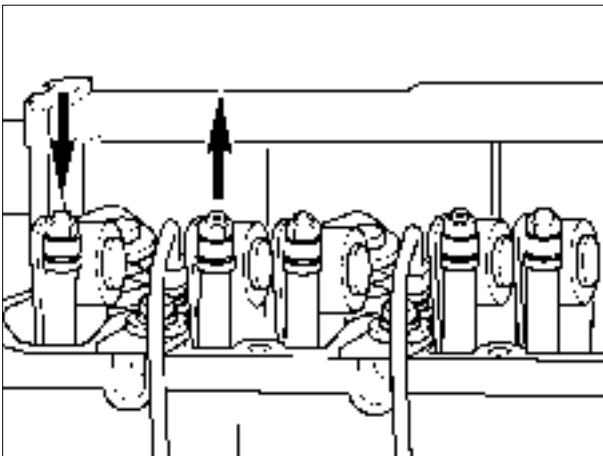

2. Set the valve clearance for each cylinder using a feeler gauge, according to the **black markings**.

Mark up the rocker arm on each set cylinder, using a chalk.

Inlet valve clearance: ..... **0.35 ±0.05 mm**  
(0.01±0.002")

Exhaust valve clearance: ..... **0.55 ±0.05 mm**  
(0.02±0.002")

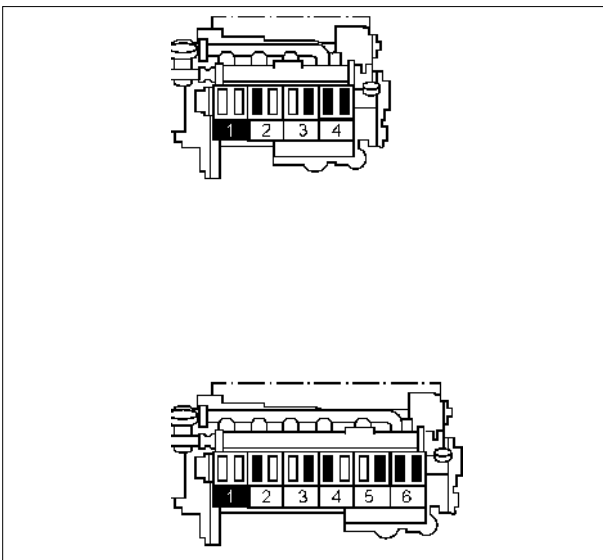

## Engine oil cooler

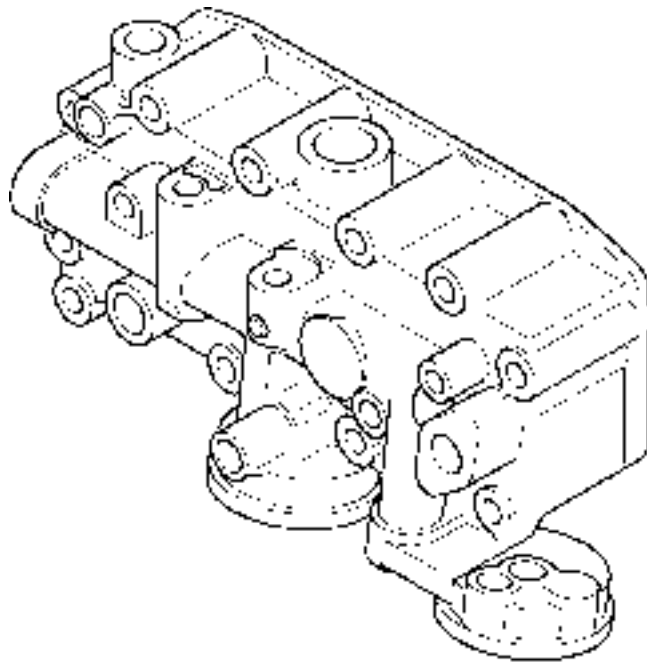

### Oil cooler, check (replace) (22311)

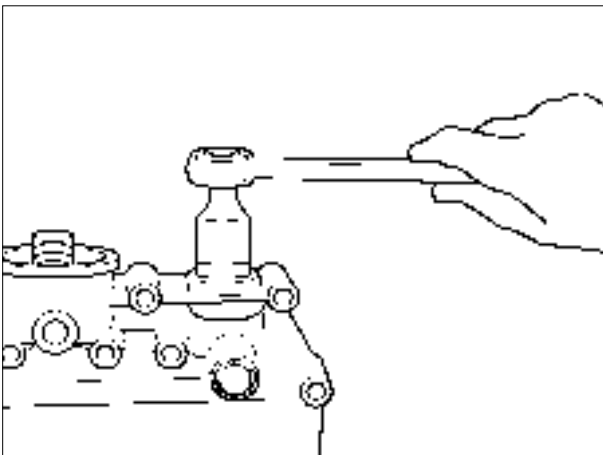

#### Check

1. Remove the Allen key plugs (17 mm).
2. Remove the hollow Allen key screws (17 mm) that hold the oil cooler.
3. Check all individual parts. If you suspect a leak, pressure-test the oil cooler and change if necessary.

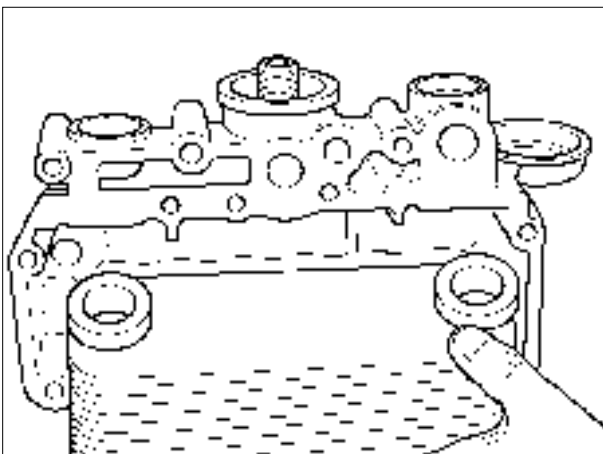

#### Replace

4. Put the oil cooler into the oil cooler housing.

### Wiring diagram (TD/TAD520, 720, 721, 722 VE stage 1 engines with start/ stop button activation)

1. Battery
2. Main switch
3. Starter motor
4. Generator
5. Hourmeter
6. Fuse
7. Start button
8. Start relay
9. Holding current relay
10. Charging control lamp 3W
11. Stop button
12. Switch for instrument light
13. Revolution counter
14. Instrument light
15. Preheating time control unit
16. Glow plugs
17. Tachometer (sender)

18. Preheater lamp
19. Temp switch excessfuel solenoid
20. Excessfuel solenoid
21. Stop solenoid
22. Signal horn
23. Water temperature gauge
24. Temp sender/switch engine
25. Alarm lamp cool water
26. Oil pressure gauge
27. Oil pressure sender/switch
28. Alarm lamp oil pressure
29. Alarm lamp water level
30. Water level switch
31. Relay
32. Diode
33. Supply button

**Conductor area**

12V		24V	
A.	90 mm <sup>2</sup> (0.140 in <sup>2</sup> )	70 mm <sup>2</sup> (0.109 in <sup>2</sup> )	
B.	10 <sup>1</sup> mm <sup>2</sup> (0.016 in <sup>2</sup> )	6 <sup>2</sup> mm <sup>2</sup> (0.009 in <sup>2</sup> )	
C.	25 mm <sup>2</sup> (0.04 in <sup>2</sup> )	25 mm <sup>2</sup> (0.04 in <sup>2</sup> )	
D.	50 mm <sup>2</sup> (0.08 in <sup>2</sup> )	25 mm <sup>2</sup> (0.04 in <sup>2</sup> )	
E.	6 mm <sup>2</sup> (0.009 in <sup>2</sup> )	25 mm <sup>2</sup> (0.04 in <sup>2</sup> )	
Unspecified area 15 mm <sup>2</sup> (0.023 in <sup>2</sup> )			
<sup>1</sup> For 6-cylinder = 16 mm <sup>2</sup> (0.025 in <sup>2</sup> )			
<sup>2</sup> For 6-cylinder = 10 mm <sup>2</sup> (0.016 in <sup>2</sup> )			

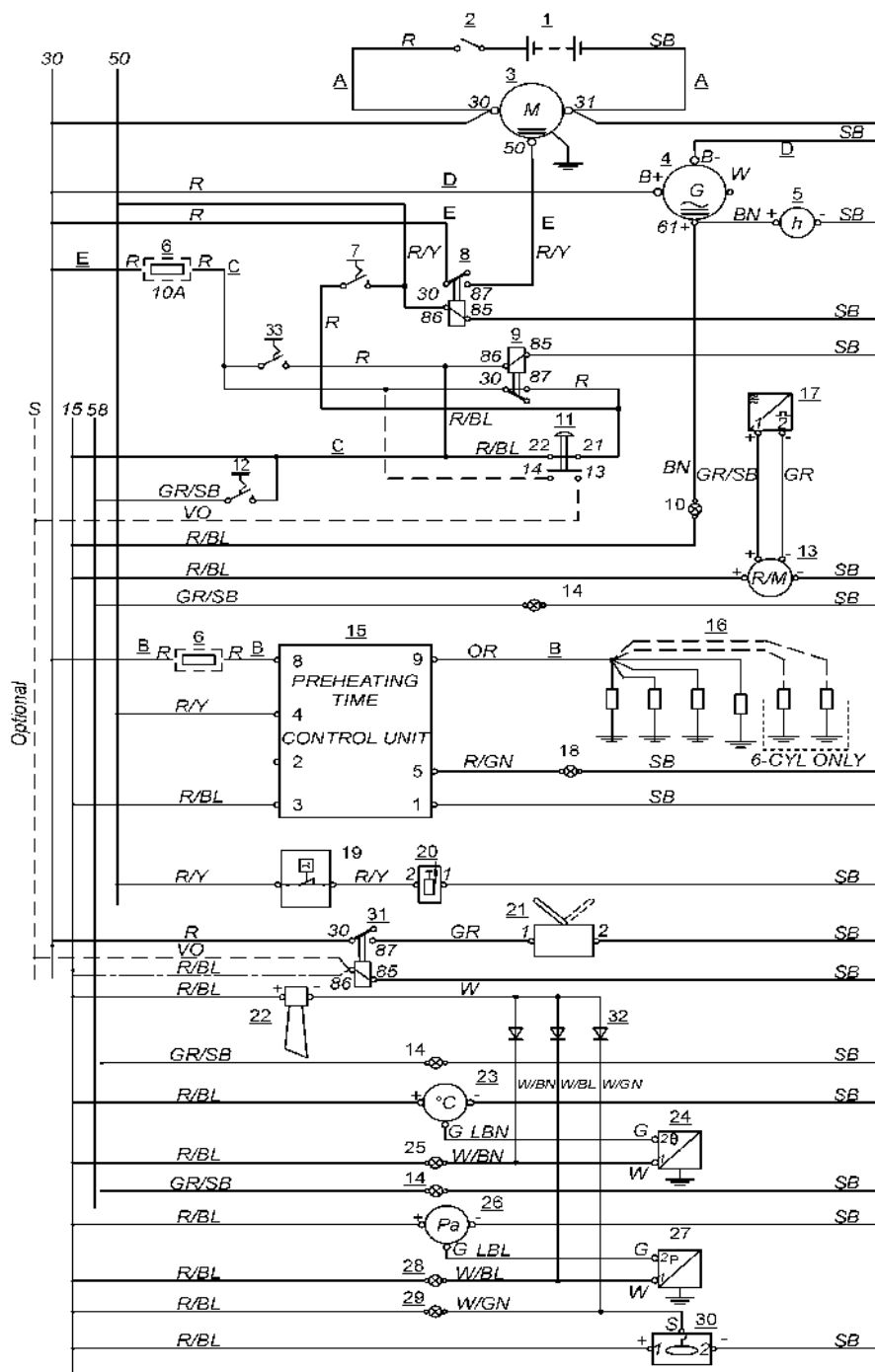

CLICK HERE TO **DOWNLOAD** THE COMPLETE MANUAL

- Thank you very much for reading the preview of the manual.
- You can download the complete manual from: [www.heydownloads.com](http://www.heydownloads.com) by clicking the link below



- Please note: If there is no response to CLICKING the link, please download this PDF first and then click on it.

CLICK HERE TO **DOWNLOAD** THE COMPLETE MANUAL