

SUZUKI

AN400

SERVICE MANUAL



CLICK HERE TO **DOWNLOAD** THE COMPLETE MANUAL

- Thank you very much for reading the preview of the manual.
- You can download the complete manual from: www.heydownloads.com by clicking the link below



- Please note: If there is no response to CLICKING the link, please download this PDF first and then click on it.

CLICK HERE TO **DOWNLOAD** THE COMPLETE MANUAL

ENGINE OIL AND TRANSMISSION OIL (FOR USA)

SUZUKI recommends the use of SUZUKI PERFORMANCE 4 MOTOR OIL or an oil which is rated SF or SG under the API (American Petroleum Institute) service classification. The recommended viscosity is SAE 10W-40. If an SAE 10W-40 oil is not available, select an alternative according to the following chart.

ENGINE OIL AND TRANSMISSION OIL (FOR OTHER COUNTRIES)

Use a premium quality 4-stroke motor oil to ensure longer service life of your motorcycle. Use only oils which are rated SF or SG under the API service classification. The recommended viscosity is SAE 10W-40. If an SAE 10W-40 motor oil is not available, select an alternative according to the right chart.

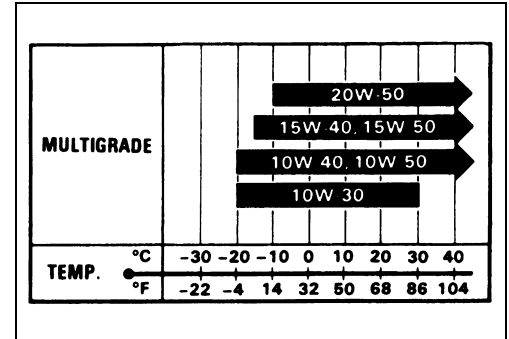

FINAL GEAR OIL

Use hypoid gear oil that meets the API service classification GL-5 and is rated SAE #90. Use a hypoid gear oil with a rating of SAE #80 if the motorcycle is operated where the ambient temperature is below 0 °C (32 °F).

BRAKE FLUID

Specification and classification: DOT 4

⚠ WARNING

Since the brake system of this motorcycle is filled with a glycol-based brake fluid by the manufacturer, do not use or mix different types of fluid such as silicone-based and petroleum-based fluid for refilling the system, otherwise serious damage will result.

Do not use any brake fluid taken from old or used or unsealed containers.

Never re-use brake fluid left over from a previous servicing, which has been stored for a long period.

FRONT FORK OIL

Use fork oil #10 or an equivalent fork oil.

ENGINE COOLANT

Use an anti-freeze/engine coolant compatible with an aluminum radiator, mixed with distilled water only.

WATER FOR MIXING

Use distilled water only. Water other than distilled water can corrode and clog the aluminum radiator.

ANTI-FREEZE/ENGINE COOLANT

The engine coolant perform as a corrosion and rust inhibitor as well as anti-freeze. Therefore, the engine coolant should be used at all times even though the atmospheric temperature in your area does not go down to freezing point.

Suzuki recommends the use of SUZUKI COOLANT anti-freeze/engine coolant. If this is not available, use an equivalent which is compatible with an aluminum radiator.

MAINTENANCE AND TUNE-UP PROCEDURES

- This section describes the servicing procedures for each item of the Periodic Maintenance requirements.

AIR CLEANER

Clean every 3 000 km (1 800 miles).

- Remove the front trunk box cover. (☞ 7-16)
- Remove the air cleaner cover ①.

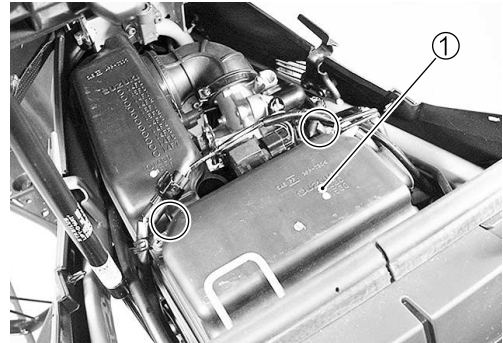

- Remove the air cleaner element ②.

NOTE:

- * When installing the air cleaner element, the letter mark on the element should be positioned outside.
- * When installing the air cleaner element retainer ③, the long side Ⓐ of the retainer flange should be positioned forward.

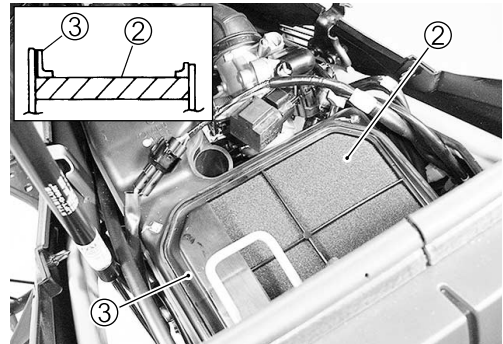

- Fill a washing pan of a proper size with a non-flammable cleaning solvent ④. Immerse the element in the cleaning solvent and wash it.
- Gently squeeze the element to remove the excess solvent: do not twist or wring the element or it will develop tears.
- Immerse the element in motor oil ⑤ and squeeze out the excess oil. The element should be wet but not dripping.
- Reinstall the cleaned or new air cleaner element in the reverse order of removal.

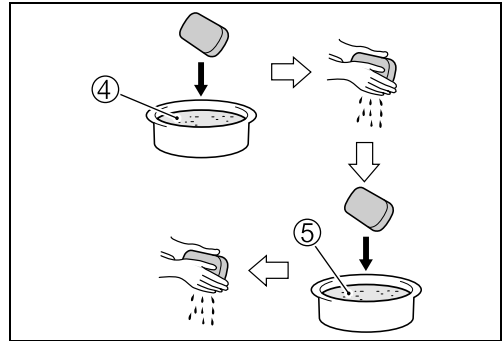

CAUTION

- * **Inspect the air cleaner element for tears. A torn element must be replaced.**
- * **If driving under dusty conditions, clean the air cleaner element more frequently. The surest way to accelerate engine wear is to use the engine without the element or to use a torn element. Make sure that the air cleaner is in good condition at all times. Life of the engine depends largely on this component!**

ENGINE COOLANT LEVEL CHECK

- Keep the motorcycle upright.
- Check the engine coolant level by observing the full and lower lines on the engine coolant reserve tank.
 - ⓕ Full line
 - Ⓛ Lower line
- If the level is below the lower line, remove the filler cap ① and add engine coolant to the full line from the engine coolant reserve tank filler.

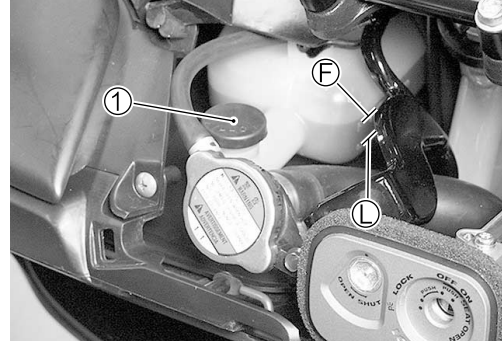

ENGINE COOLANT CHANGE

- Remove the left side leg shield. (☞ 7-15)
- Remove the radiator cap ①.



- Drain engine coolant by disconnecting the water hoses ② and ③.



⚠ WARNING

- * Do not open the radiator cap when the engine is hot, as you may be injured by escaping hot liquid or vapor.
- * Engine coolant may be harmful if swallowed or if it comes in contact with skin or eyes. If engine coolant gets into the eyes or in contact with the skin, flush thoroughly with plenty of water. If swallowed, induce vomiting and call physician immediately!

- Flush the radiator with fresh water if necessary.
- Pour the specified engine coolant up to the radiator inlet.
- Bleed the air from the engine coolant circuit as following procedure.

NOTE:

For engine coolant information, refer to page 6-3.

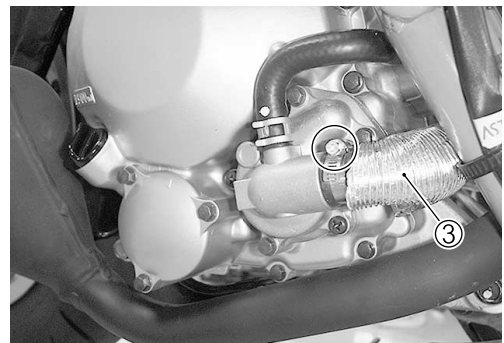

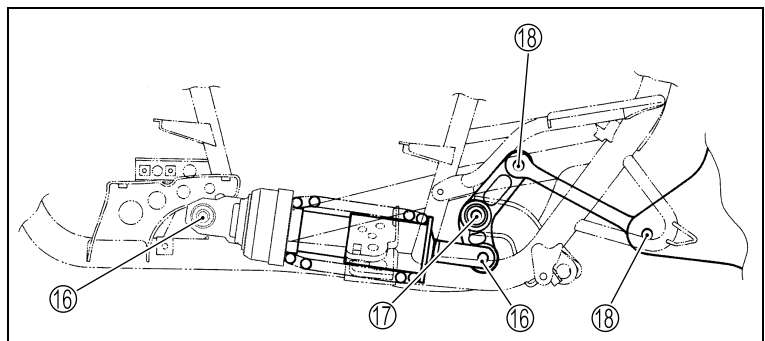
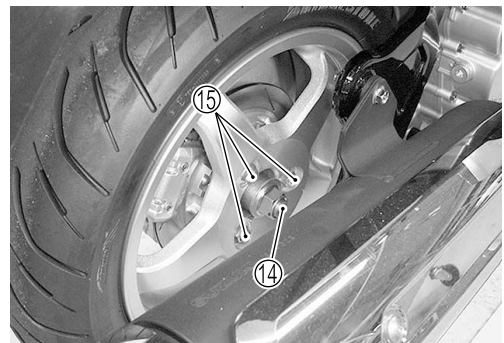
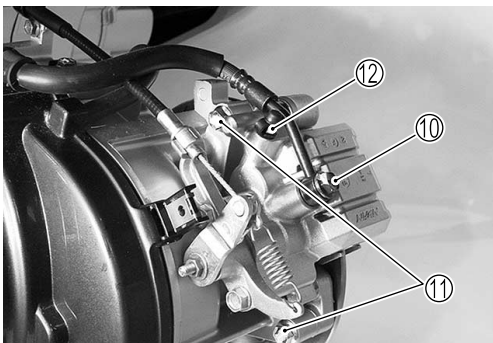
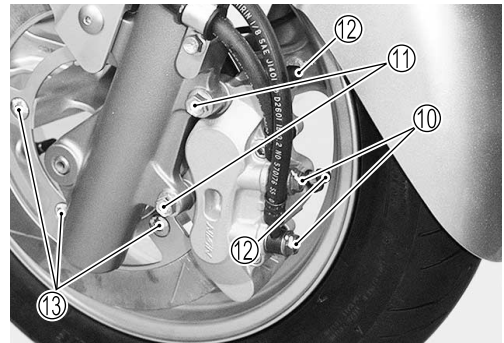
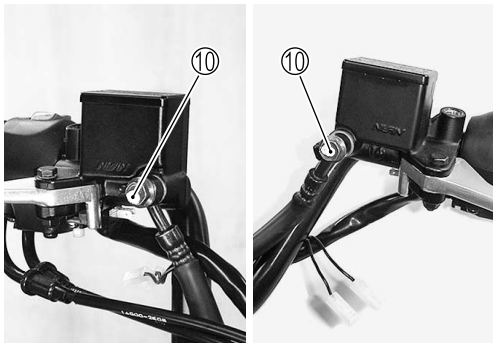
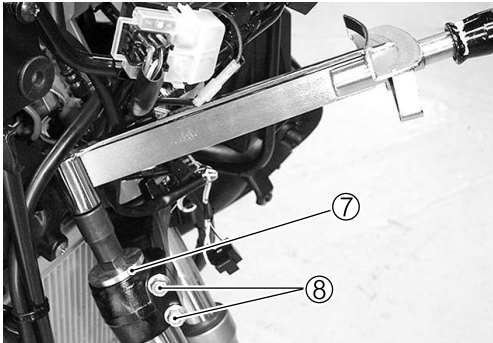
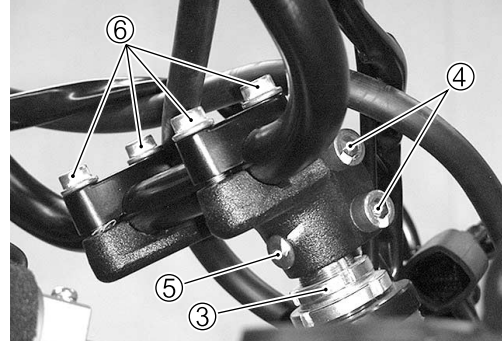
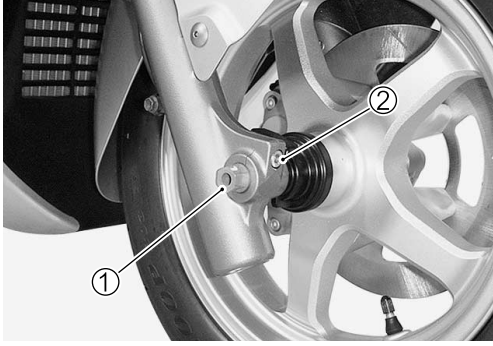

- Remove the PAIR hose ①.

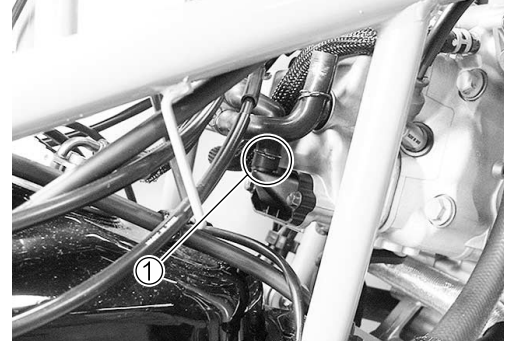

- Remove the intake pipe bolts and then remove the intake pipe ② along with the throttle body ③.
- Remove the O-rings ④ and insulator ⑤.

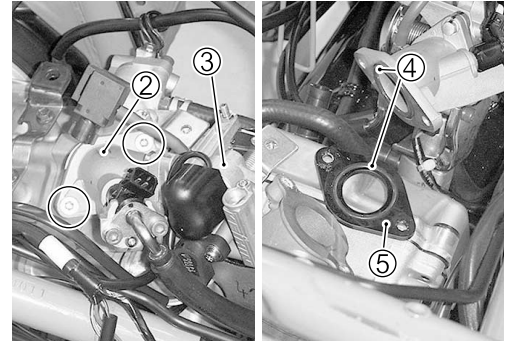

- Disconnect the starter motor lead wire ⑥ and engine ground lead wire ⑦.

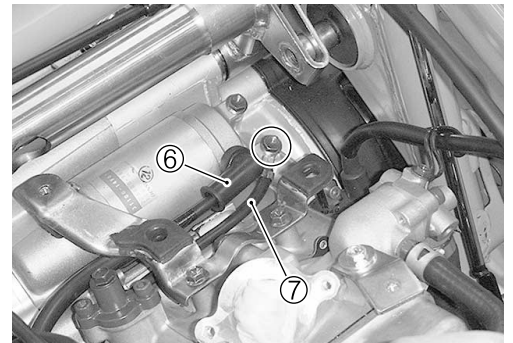

- Disconnect the generator coupler ⑧ and CKP sensor coupler ⑨.

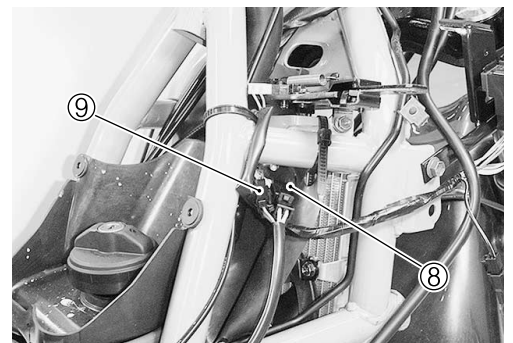

- Disconnect the clamps ⑩, ⑪.



- Remove the oil filter cap ①.

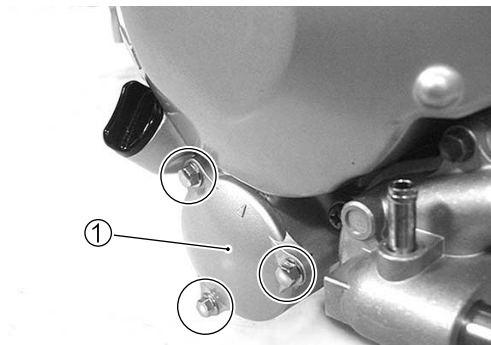

- Remove the O-ring ②.
- Remove the oil filter ③.
- Remove the O-ring ④.

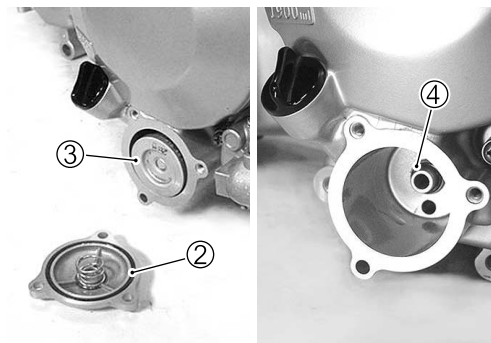

- Remove the water pump ⑤.

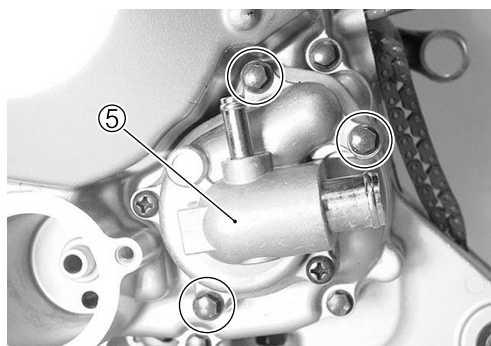

- Remove the O-ring ⑥.

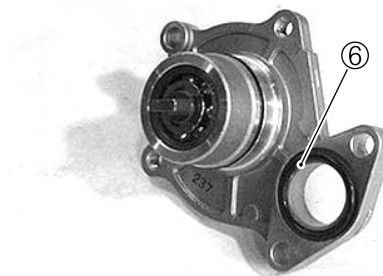

- Remove the generator cover ⑦.

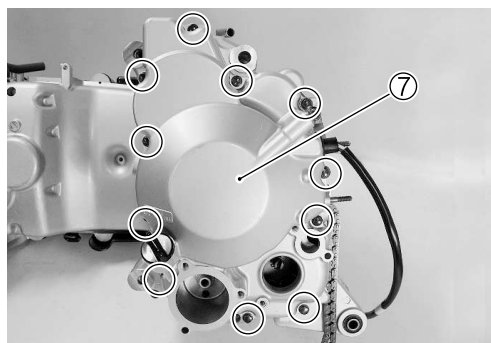

CYLINDER HEAD

DISASSEMBLY

- Compress the valve spring ① using the special tools.

TOOL 09916-14510: Valve lifter
09916-14910: Attachment

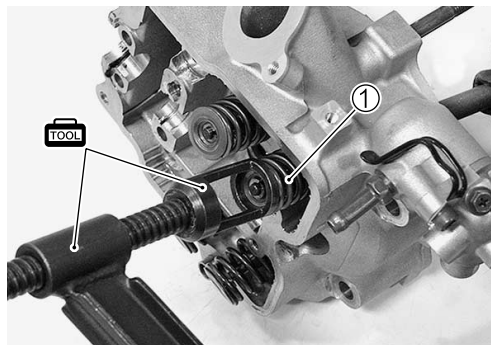

- Remove the cotter halves ②.

TOOL 09916-84511: Tweezers

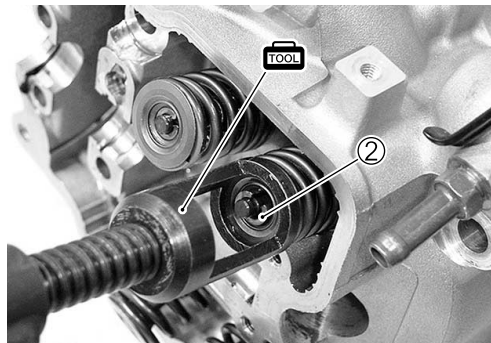

- Remove the valve spring retainer ③.
- Remove the spring ④.



- Remove the valve ⑤ from the other side.
- Remove the valve stem seal ⑥.
- Remove the spring seat ⑦.

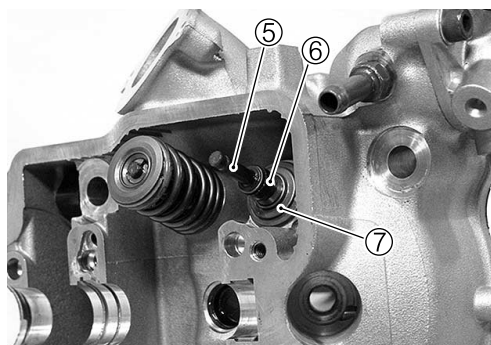

- Remove the cam chain tensioner bolt ⑧ and gasket washer ⑨.
- Remove the cam chain tensioner ⑩.

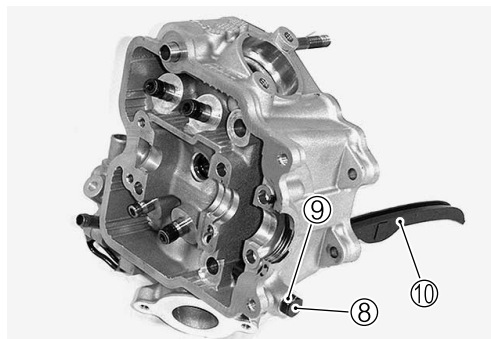

CAMSHAFT

CAM WEAR INSPECTION

- Check the sliding surface for extraordinary.
- Measure the cam height H with a micrometer.
- If the service limit has been exceeded, replace the camshaft.

DATA Cam height H : Service Limit: (IN) 33.13 mm (1.30 in)
(EX) 33.00 mm (1.30 in)

TOOL 09900-20202: Micrometer (25 – 50 mm)

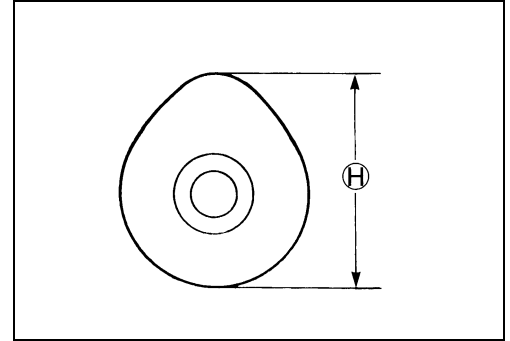

CAMSHAFT JOURNAL WEAR INSPECTION

- Place the plastigauge between the camshaft ① and camshaft holder and tighten the camshaft holder bolt to the specified torque.

TOOL 09900-22301: Plastigauge
09900-22302: Plastigauge

U Camshaft holder bolt: 10 N·m (1.0 kgf·m, 7.0 lb-ft)

NOTE:

Do not rotate the camshaft after the camshaft holder has been tightened with the plastigauge in place.

- Remove the camshaft holders and read the width of the compressed plastigauge with envelope scale.
- This measurement should be taken at the widest part.

DATA Camshaft journal oil clearance:
Service Limit: ($\phi 22$) 0.15 mm (0.006 in)
($\phi 17.5$) 0.15 mm (0.006 in)

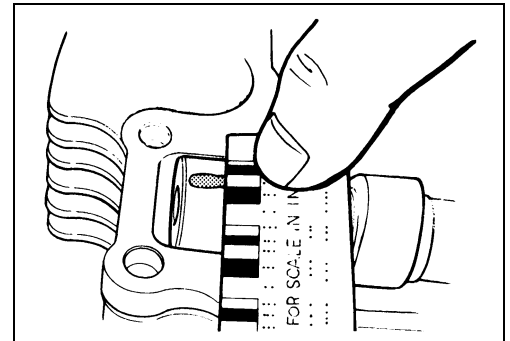
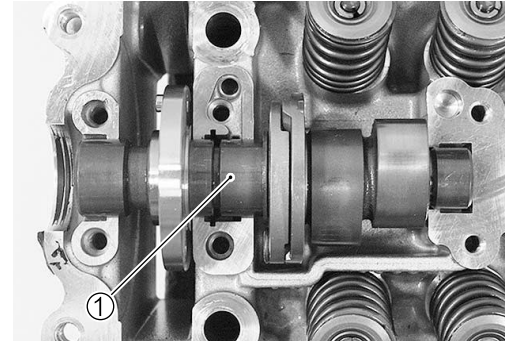

- Loosen the special tool handle ① slowly and remove the clutch shoe assembly.

CAUTION

Do not attempt to disassemble the clutch shoe assembly.



- To remove the movable driven face seat ③, use a thin brade screwdriver.



- Remove three pins ④ together with rollers.



- Remove the rollers ⑤ from the pins.



- Remove the movable driven face ⑥ from the fixed driven face.



- Remove the bearing ② using the special tool.

TOOL 09921-20240: Bearing remover set (35 mm)

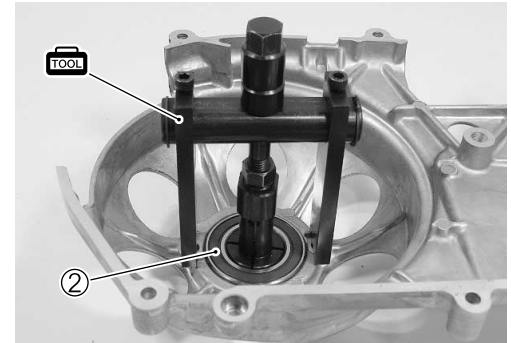

REASSEMBLY

- Reassemble the bearing in the reverse order of removal.
- Pay attention to the following points:
- Install the bearing using the special tool.

TOOL 09913-70210: Bearing installer set (62 × 68 mm)



DRIVE V-BELT INSPECTION

- Check that the drive V-belt is free from any greasy substance.
- Check the contact surface for crack or other damage.
- Measure the width \textcircled{A} of the belt using the vernier calipers.
- If the measurement exceeds the service limit or crack or other damage exists, replace the belt with a new one.

DATA Drive V-belt width: Service Limit: 20.85 mm (0.82 in)

TOOL 09900-20102: Vernier Calipers

CAUTION

If grease or oil is present on the surface, degrease the belt thoroughly.

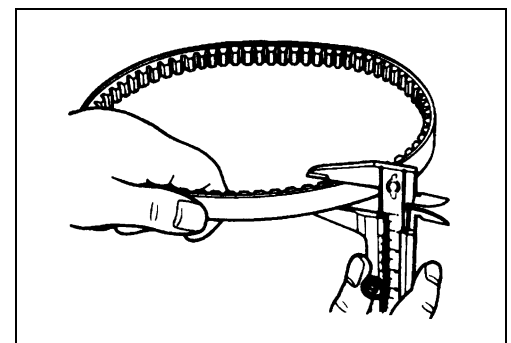
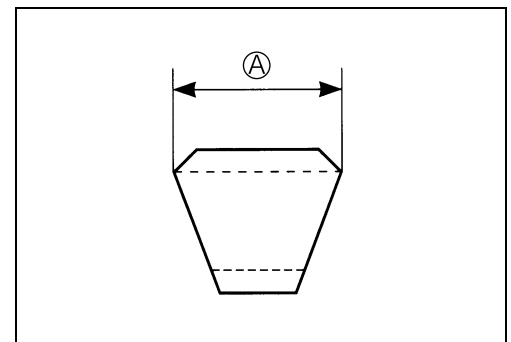

ENGINE REASSEMBLY

- Reassemble the engine in the reverse order of disassembly.
- Pay attention to the following point:

CAUTION

- * Make sure to coat the rotating and sliding sections with engine oil.
- * Care must be taken so that the drive belt, drive face and driven face are completely free from oil and grease.

CRANKSHAFT

- Using the special tool, press in the crankshaft into the left crankcase.

NOTE:

Fit steel plates between the crankcase and the special tool when installing the crankshaft with the special tool.

 09910-32812: Crankshaft installer
09910-32870: Attachment

CAUTION

- * Do not hit the crankshaft with a plastic hammer or the like to install it into the crankcase.
- * Be careful not to cause damage to the oil seal lip when pressing the crankshaft into the crankcase.

BALANCER SHAFT

- Install the balancer shaft ①.

CRANKCASE

- Install the O-ring ①.

CAUTION

Replace the O-ring with new a one.

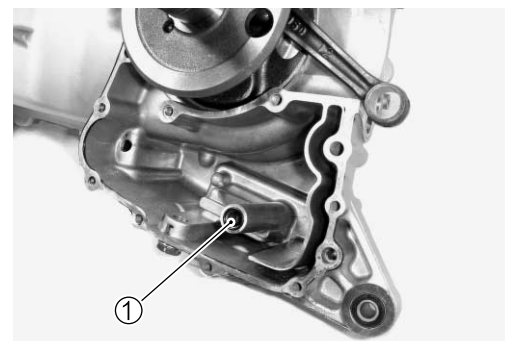
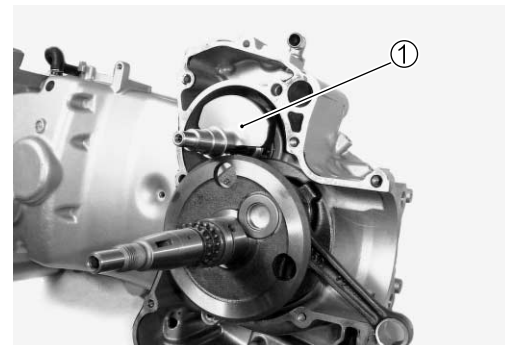
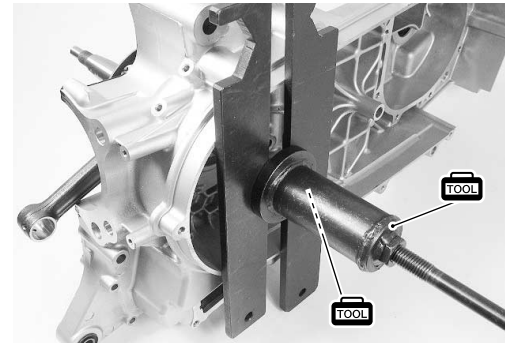

- Install the clutch inner cover ③.
- Tighten the clutch inner cover bolts to the specified torque.

 **Clutch inner cover bolt: 11 N·m (1.1 kgf-m, 8.0 lb-ft)**

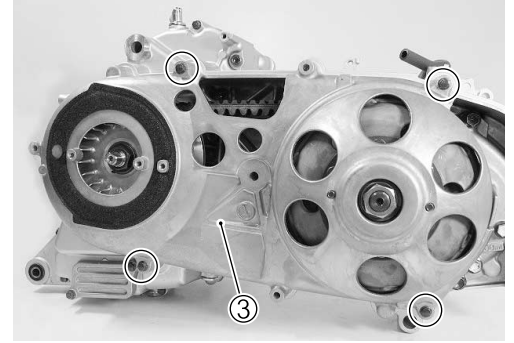

GENERATOR COVER

- Install the dowel pins ① and gasket ②.

CAUTION

Replace the gasket with a new one.

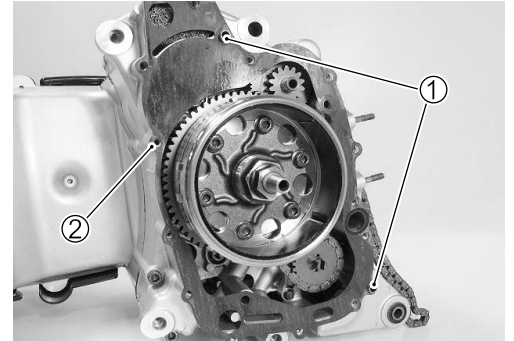

- Install the generator cover ③.
- Tighten the generator cover bolts to the specified torque.

CAUTION

- * Fit the gasket washer to the bolts ④.
- * Replace the gaskets with new ones.

 **Generator cover bolt: 11 N·m (1.1 kgf-m, 8.0 lb-ft)**

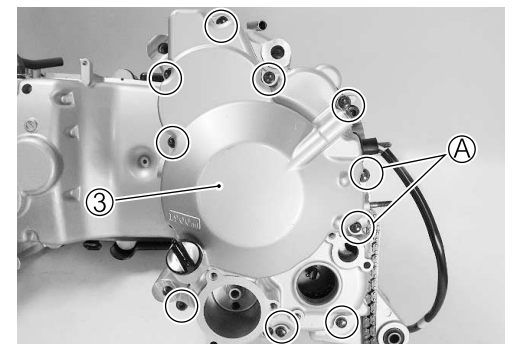

WATER PUMP

- Install the O-rings ①, ② to the water pump.

CAUTION

Replace the O-rings with new ones.

- Apply a small amount of engine oil to the O-rings.

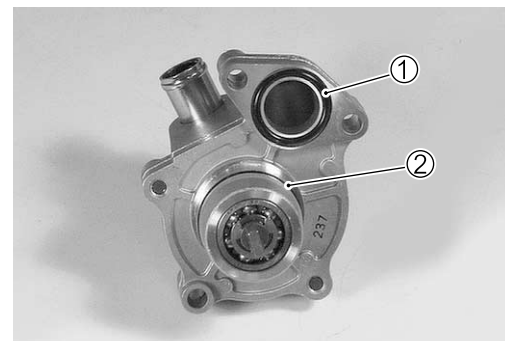

- Install the water pump ③.

CAUTION

Align the flats ④ of the water pump shaft end with the slot ⑤ of the oil pump shaft.

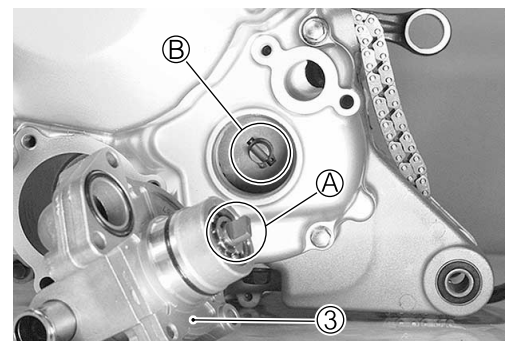

- When connecting meter probe from the terminal side of the coupler (connection from harness side not being possible), use extra care not to force and cause the male terminal to bend or the female terminal to open.

Connect the probe as shown to avoid opening of female terminal.

Never push in the probe where male terminal is supposed to fit.

- Check the male connector for bend and female connector for excessive opening. Also check the coupler for locking (looseness), corrosion, dust, etc.

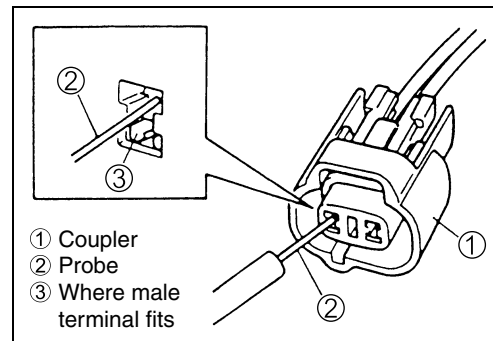

FUSE

- When a fuse blows, always investigate the cause correct it and then replace the fuse.
- Do not use a fuse of a different capacity.
- Do not use wire or any other substitute for the fuse.

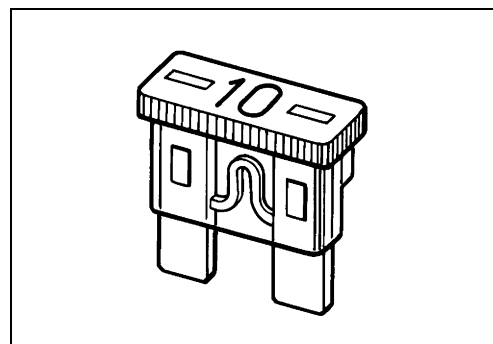

ECM/VARIOUS SENSORS

- Since each component is a high-precision part, great care should be taken not to apply any sharp impacts during removal and installation.

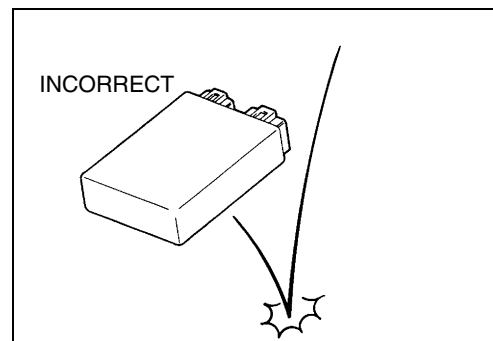

- Be careful not to touch the electrical terminals of the ECM. The static electricity from your body may damage this part.

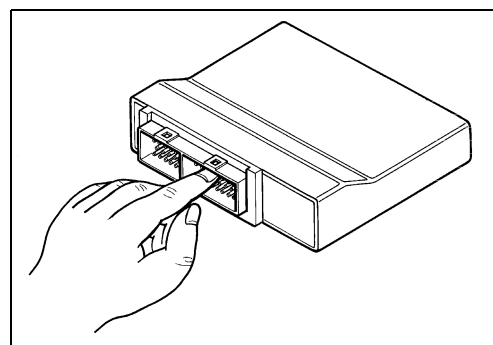

FI SYSTEM WIRING DIAGRAM

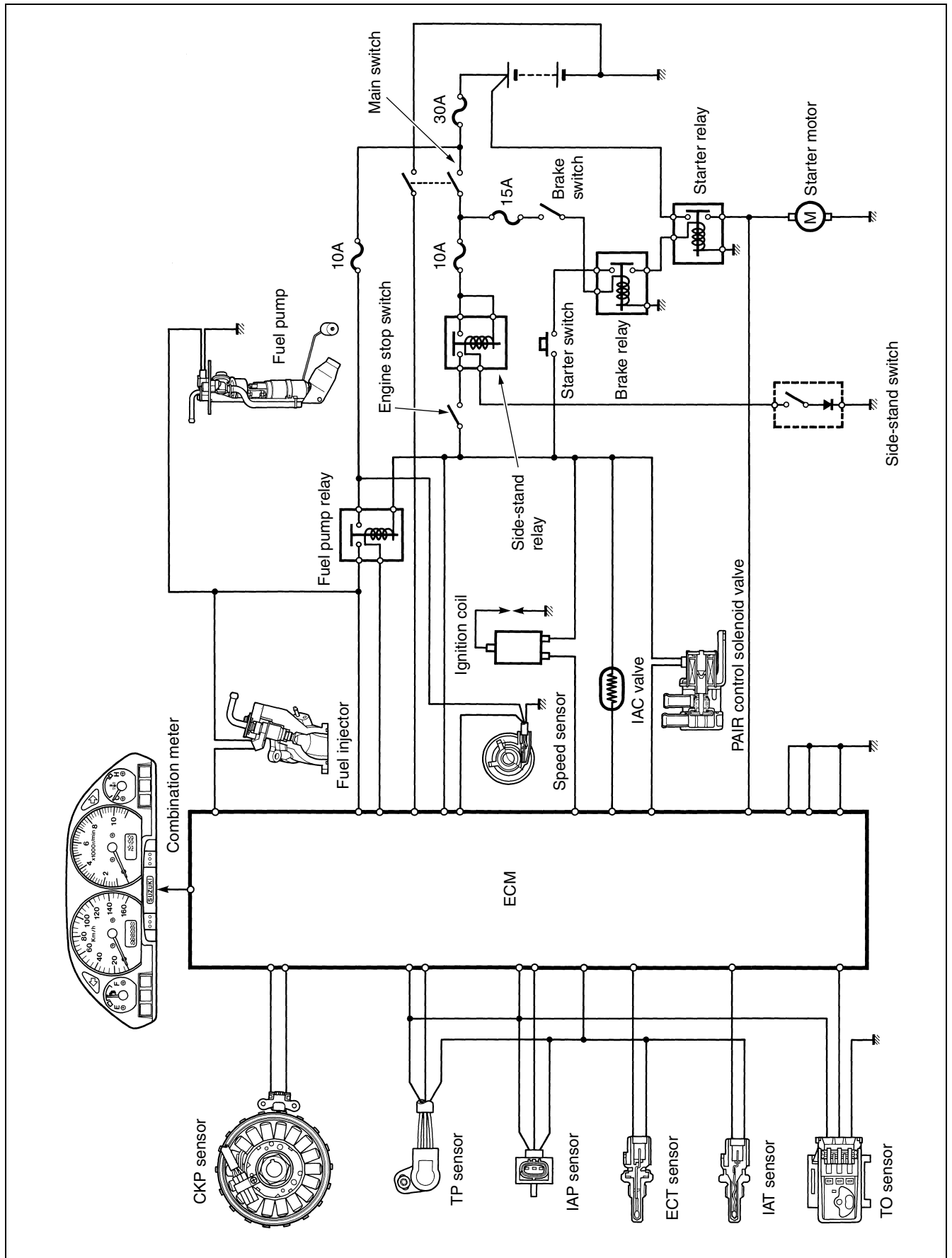

“C12” CKP SENSOR CIRCUIT MALFUNCTION

DETECTED CONDITION	POSSIBLE CAUSE
No CKP sensor signal for more than 2 seconds after receiving the starter signal.	<ul style="list-style-type: none"> • Metal particles or foreign material being attached on the CKP sensor and rotor tip. • CKP sensor circuit open or short. • CKP sensor malfunction. • ECM malfunction.

INSPECTION

Step1

- 1) Remove the front box. (☞ 7-14)
- 2) Turn the ignition switch OFF.
- 3) Check the CKP sensor coupler ① for loose or poor contacts.
If OK, then measure the CKP sensor resistance.

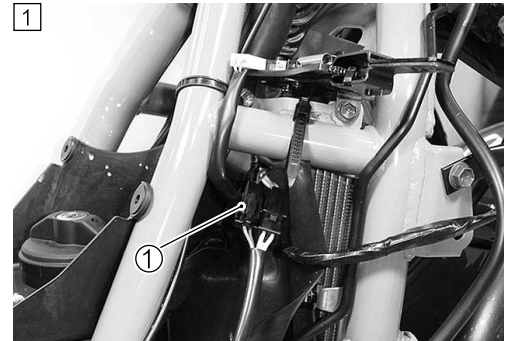

- 4) Disconnect the CKP sensor coupler ① and measure the resistance.

DATA CKP sensor resistance: 180 – 280 Ω
(Blue – Green)

- 5) If OK, then check the continuity between each terminal and ground.

DATA CKP sensor continuity: ∞ Ω (Infinity)
(Blue – Ground)
(Green – Ground)

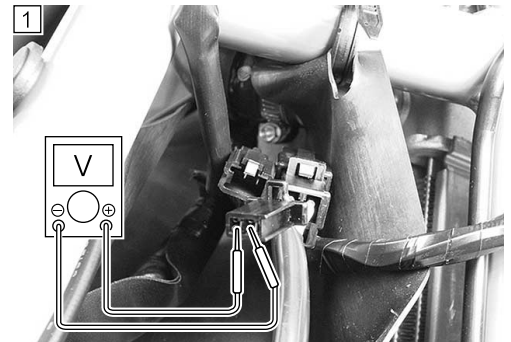

TOOL 09900-25008: Multi circuit tester set

Tester knob indication: Resistance (Ω)

Are the resistance and continuity OK?

YES	Go to step 2.
NO	Replace the CKP sensor with a new one.

“C21” IAT SENSOR CIRCUIT MALFUNCTION

DETECTED CONDITION	POSSIBLE CAUSE
Output voltage low or high ($0.20 \leq \text{Sensor voltage} < 4.80 \text{ V}$) (without the above range.)	<ul style="list-style-type: none"> IAT sensor circuit open or short. IAT sensor malfunction. ECM malfunction.

INSPECTION

Step 1

- Remove the frame cover. (→ 7-18)
- Turn the ignition switch OFF.
- Check the IAT sensor coupler for loose or poor contacts.
If OK, then measure the IAT sensor voltage at the wire side coupler.
- Disconnect the coupler ① and turn the ignition switch ON.

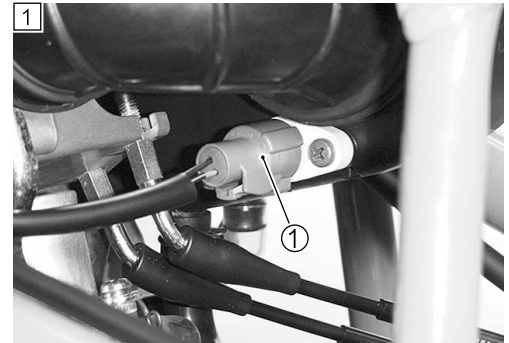

- Measure the voltage between B/BI wire terminal and ground.
- If OK, then measure the voltage between B/BI wire terminal and B/Br wire terminal.

DATA IAT sensor voltage: 4.5 – 5.5 V
 (+ B/BI – (–) Ground)
 (+ B/BI – (–) B/Br)

TOOL 09900-25008: Multi circuit tester set

Tester knob indication: Voltage (---)

Is the voltage OK?

YES	Go to Step 2
NO	<ul style="list-style-type: none"> Loose or poor contacts on the ECM coupler. Open or short circuit in the B/BI wire or B/Br wire.

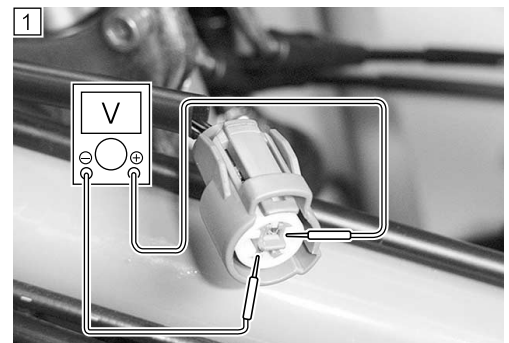
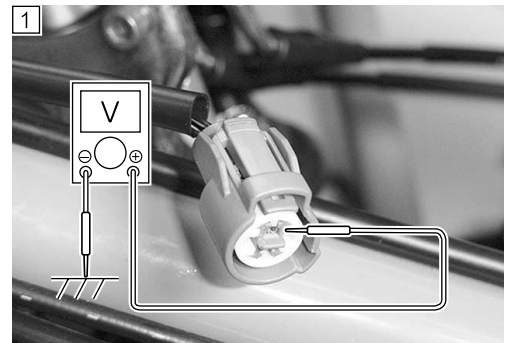

Step 2

- 1) Turn the ignition switch OFF.
- 2) Turn the ignition switch ON and measure the heater voltage between O/W wire (ECM side) and ground.
- 3) If the tester voltage indicates the battery voltage for few seconds, it is good condition.

DATA Heater voltage: **Battery voltage**
(O/W – Ground)

NOTE:

Battery voltage can be detected only during few seconds after ignition switch is turned ON.

TOOL 09900-25008: Multi circuit tester set

Tester knob indication: Voltage (V)

Is the voltage OK?

YES	Go to Step 3
NO	Replace the HO2 sensor with a new one.

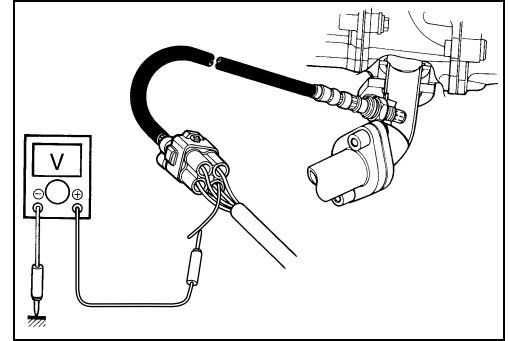

Step 3

- 1) Turn the ignition switch OFF.
- 2) Disconnect the HO2 sensor coupler.
- 3) Check the resistance between the terminals (White – White) of the HO2 sensor.

DATA HO2 heater resistance: **11.5 – 14.5 Ω (at 23 °C/73.4 °F)**
(White – White)

NOTE:

- * Temperature of the sensor affects resistance value largely.
- * Make sure that the sensor heater is at correct temperature.

TOOL 09900-25008: Multi circuit tester set

Tester knob indication: Resistance (Ω)

Is the resistance OK?

YES	<ul style="list-style-type: none"> • Black, Gray or White wire open or shorted to ground, or poor ①①, ①⑤, ②① or ②⑥ connection. • If wire and connection are OK, intermittent trouble or faulty ECM. • Recheck each terminal and wire harness for open circuit and poor connection.
NO	Replace the HO2 sensor with a new one.

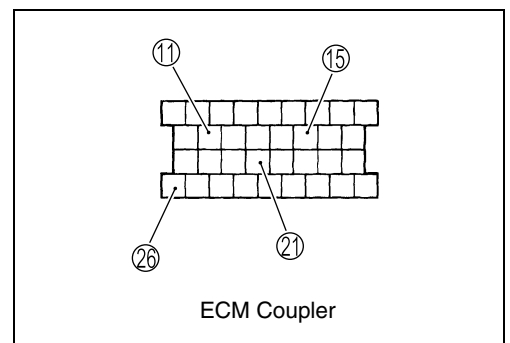
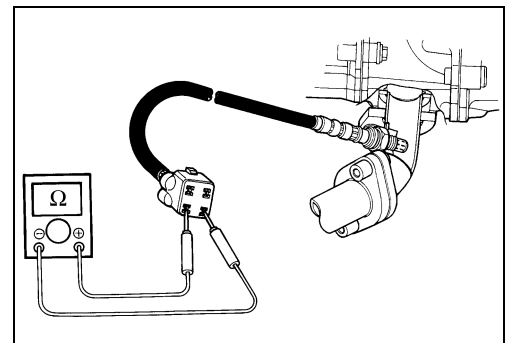

- If the fuel pressure is higher than the specification, inspect the following items:
 - * Fuel pump check valve
 - * Pressure regulator

⚠ WARNING

- * Before removing the special tools, turn the ignition switch to OFF position and release the fuel pressure slowly.
- * Gasoline is highly flammable and explosive. Keep heat, spark and flame away.

FUEL PUMP INSPECTION

- Turn the ignition switch ON and check that the fuel pump operates for few seconds.
- If the fuel pumps motor does not make operating sound, replace the fuel pump assembly or inspect the fuel pump relay and tip over sensor.

FUEL DISCHARGE AMOUNT INSPECTION

⚠ WARNING

Gasoline is highly flammable and explosive. Keep heat, spark and flame away.

- Remove the front box. (☞ 7-14)
- Disconnect the fuel delivery pipe from the fuel injector.
- Place the measuring cylinder and insert the fuel delivery pipe end into the measuring cylinder.
- Disconnect the ECM lead wire coupler.
- With the lead wire's fastener (A) unlocked, pull out the power source lead wire (Yellow with red tracer) ①.
- Apply 12 volts to the fuel pump for 10 seconds and measure the amount of fuel discharged.
- If the pump does not discharge the amount specified, it means that the fuel pump is defective or that the fuel filter is clogged.

DATA Fuel discharge amount: 35 ml and more/10 sec.
(1.18/1.23 US/Imp oz)/10 sec.

NOTE:

The battery must be in fully charged condition.

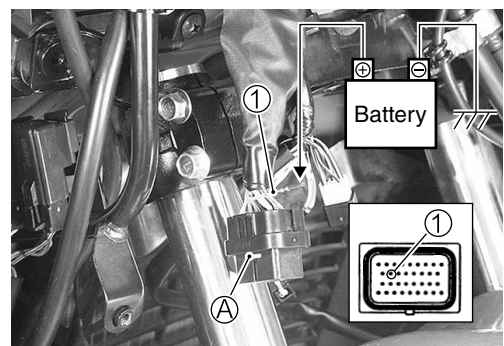
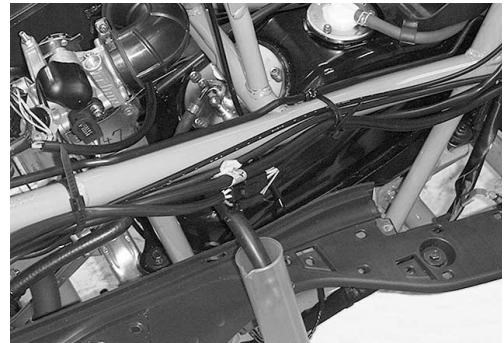

CLICK HERE TO **DOWNLOAD** THE COMPLETE MANUAL

- Thank you very much for reading the preview of the manual.
- You can download the complete manual from: www.heydownloads.com by clicking the link below



- Please note: If there is no response to CLICKING the link, please download this PDF first and then click on it.

CLICK HERE TO **DOWNLOAD** THE COMPLETE MANUAL

CLEANING AND INSPECTION

- Clean all passageways with a spray-type carburetor cleaner and blow dry with compressed air.

⚠ WARNING

Some carburetor cleaning chemicals, especially dip-type soaking solutions, are very corrosive and must be handled carefully. Always follow the chemical manufacturer's instructions on proper use, handling and storage.

- Check following items any damage or clogging.
 - * Throttle shaft bushing and seal
 - * Throttle valve
 - * Idle adjust screw
 - * Vacuum hose
 - * Injector seal
 - * Fuel injector
 - * O-ring
 - * Throttle body
 - * Intake pipe

CAUTION

Do not use wire to clean passageways. Wire can damage passageways. If the components cannot be cleaned with a spray cleaner it may be necessary to use a dip-type cleaning solution and allow them to soak. Always follow the chemical manufacturer's instructions for proper use and cleaning of the throttle body components. Do not apply carburetor cleaning chemicals to the rubber and plastic materials.

IAC VALVE INSPECTION

- The IAC valve can be checked without removing it from the throttle body.
- Inspect the IAC valve. (👉 4-39)



COOLING FAN THERMO-SWITCH

The cooling fan is secured behind the radiator by three bolts and is automatically controlled by the thermo-switch. The thermo-switch remains open when the temperature of the engine coolant is low, but closes when the temperature reaches approximately 93 °C(199 °F) setting the cooling fan in motion.

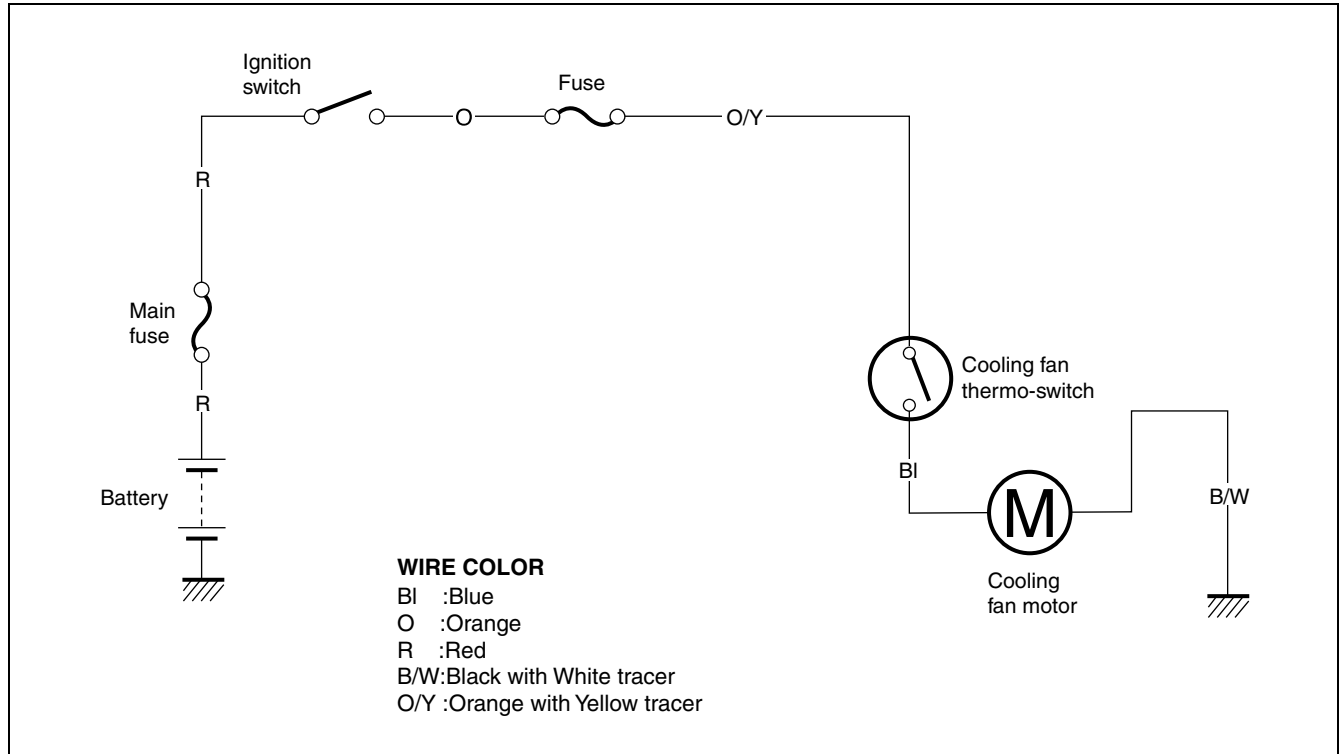

ENGINE LUBRICATION SYSTEM

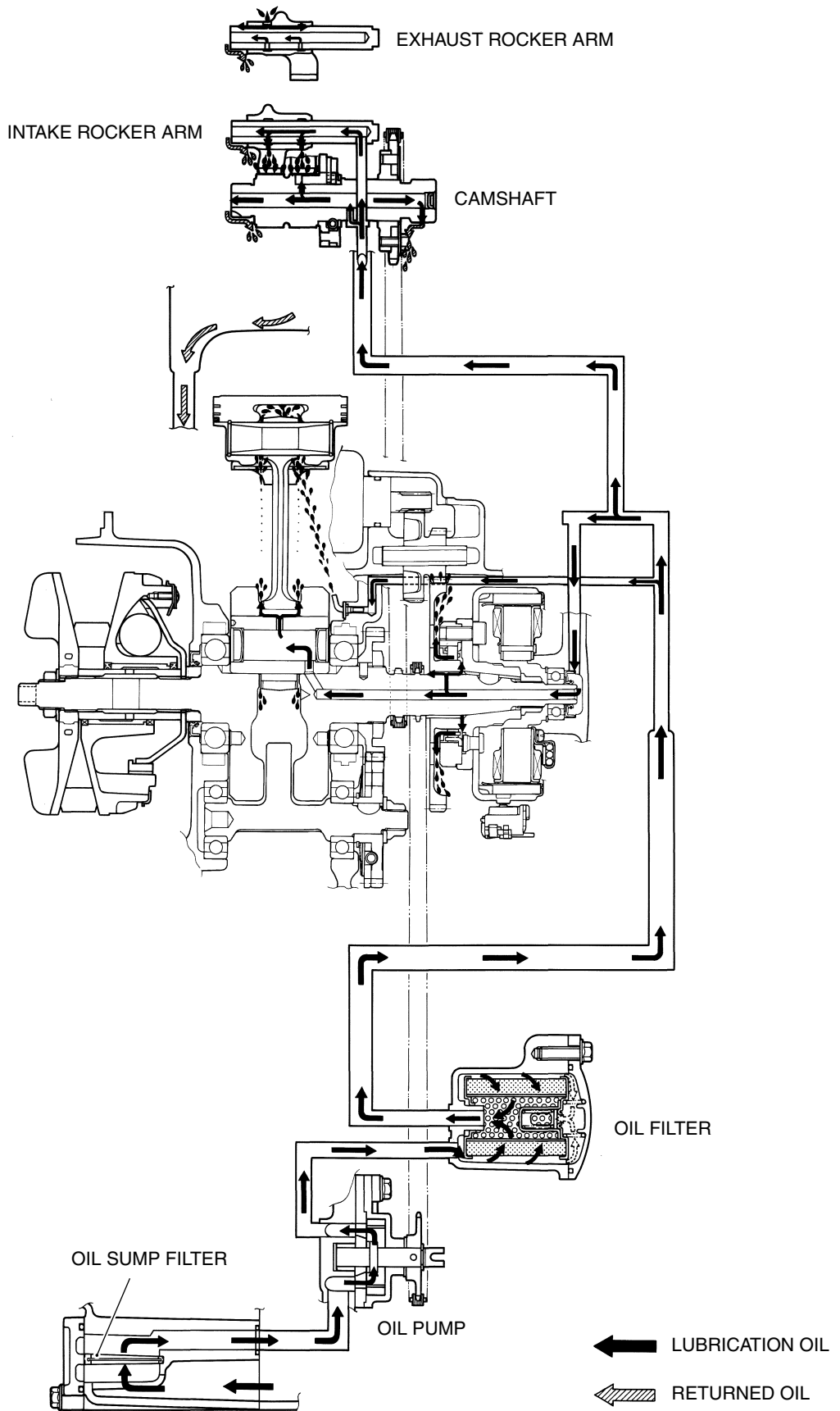

FASTENER REMOVAL AND REINSTALLATION

REMOVAL

- Depress the head of fastener center piece ①.
- Pull out the fastener.

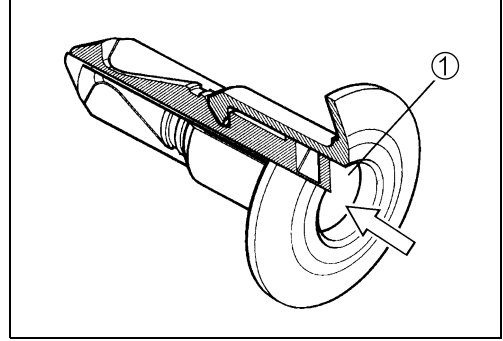

INSTALLATION

- Let the center piece stick out toward the head so that the pawls ② close.
- Insert the fastener into the installation hole.

NOTE:

To prevent the pawl ② from damage, insert the fastener all the way into the installation hole.

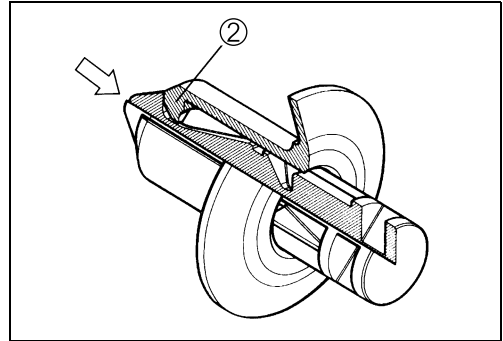

- Push in the head of center piece until it becomes flush with the fastener outside face.

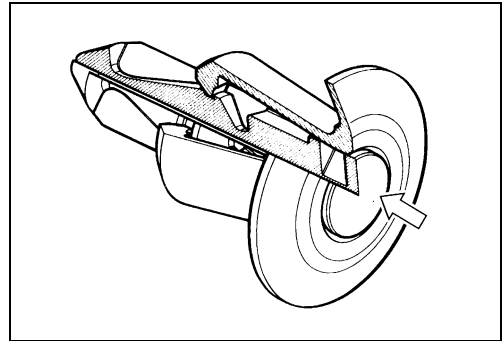

FRONT WHEEL

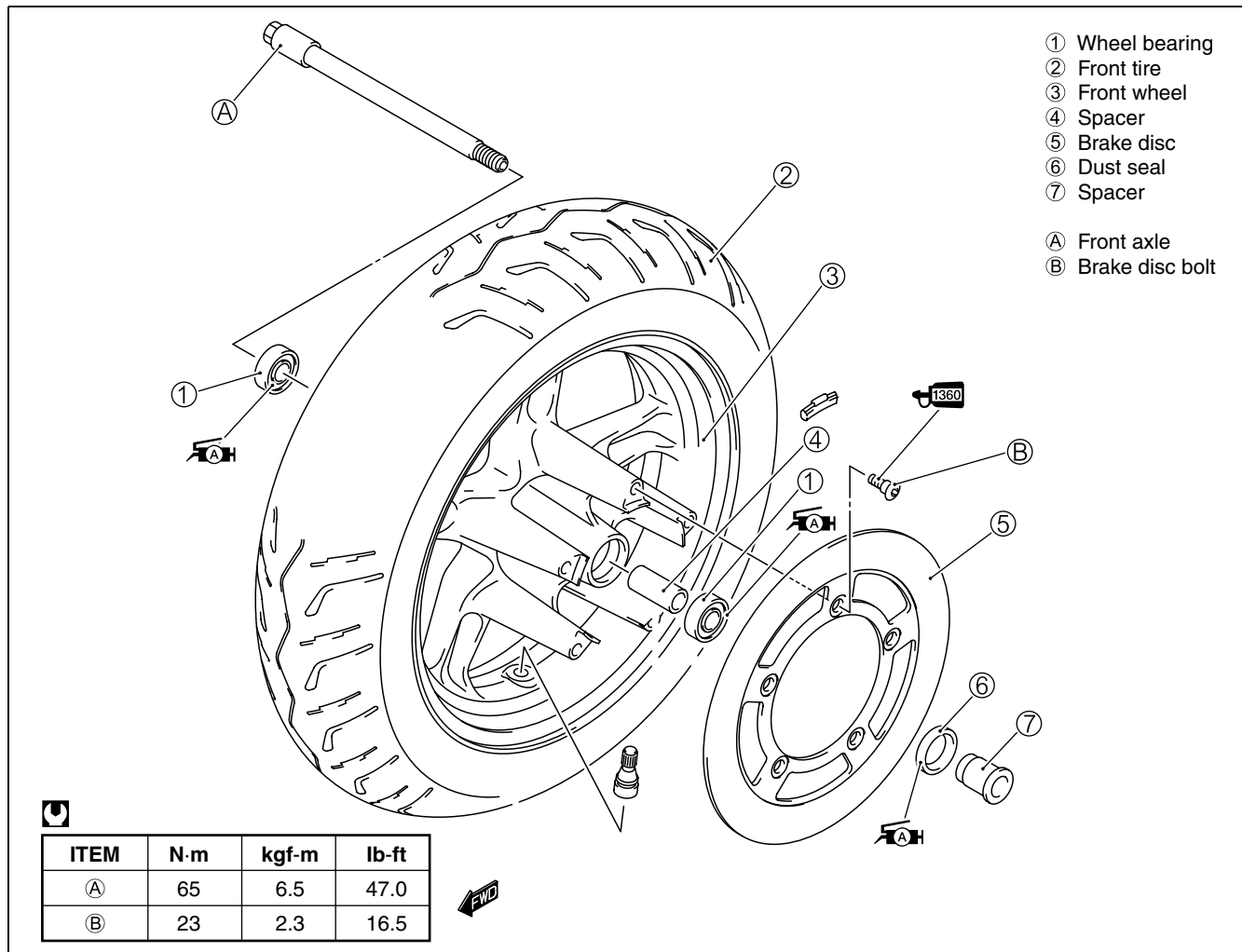

REMOVAL AND DISASSEMBLY

- Loosen the axle pinch bolt ① and then the front axle ②.
- Lift the front wheel off the ground using a jack.

CAUTION

When using a jack, take care not to cause scratches on the chassis.

NOTE:

In this operation, the clamp bolt ③ should be removed so as not to cause the speed sensor lead wires to be pulled tight.

- Draw out the front axle and remove the front wheel.

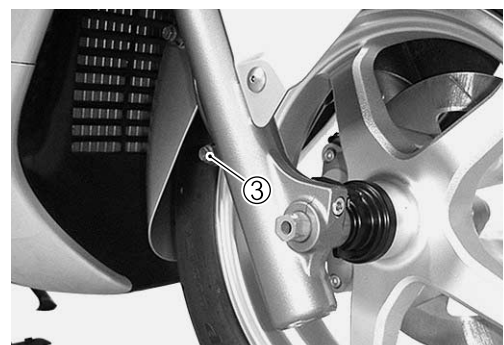
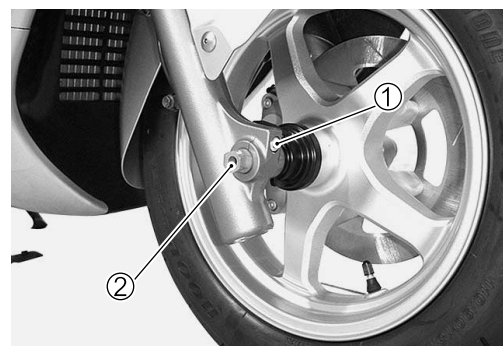

- Remove the master cylinder ④.

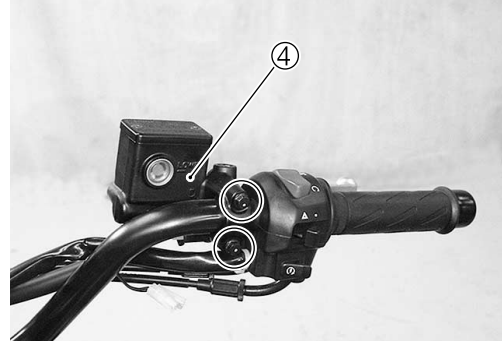

- Remove the brake light switch ⑤ and brake lever ⑥.

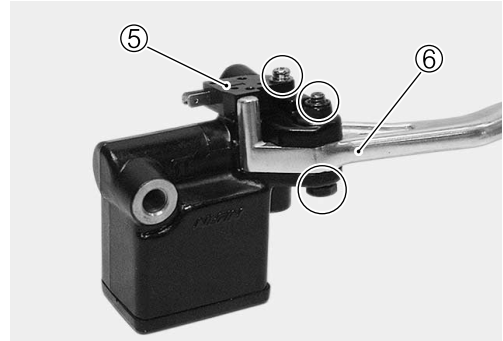

- Remove the boot ⑦ and remove the snap ring ⑧.
- Remove the piston/cup set ⑨ and spring ⑩.

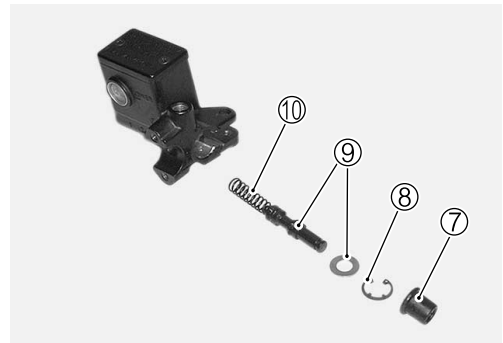

MASTER CYLINDER INSPECTION

- Inspect the cylinder wall, piston/cup set and spring for scratch, corrosion or other damages.
- If any abnormal condition is noted, replace the inner parts or master cylinder.



- Install the oil lock piece ① into the inner tube.
- Install the inner tube into the outer tube with care not to drop the oil lock piece out.

NOTE:

After installing the inner tube into the outer tube, keep the oil lock piece into the inner tube by compressing the front fork fully.

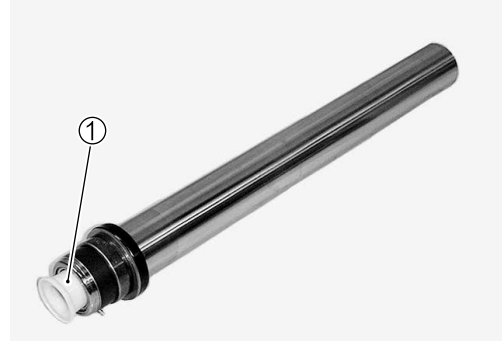

- Apply SUZUKI SUPER GREASE to the lip of the oil seal ②.
- Install the oil seal ② into the outer tube using the special tool.

 99000-25010: SUZUKI SUPER GREASE "A" (Others)
99000-25030: SUZUKI SUPER GREASE "A" (USA)

 09940-52861: Front fork oil seal installer set

CAUTION

Wash clean the front fork oil seal installer before using. If dirt is on the installer, the inner tube may possibly be damaged during press-fitting work.

- Fit the stopper ring ③ and dust seal ④.

CAUTION

Make sure that the stopper ring is securely fitted into the groove on the outer tube.

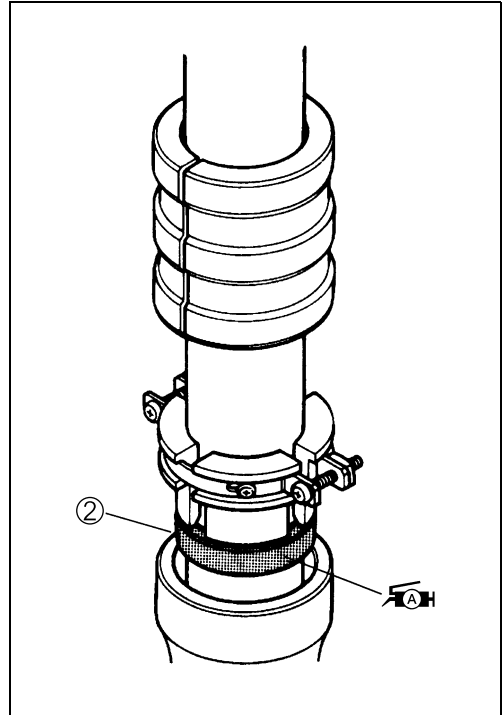

- ② Oil seal
- ③ Oil seal stopper ring
- ④ Dust seal
- ⑤ Oil seal retainer
- ⑥ Guide metal

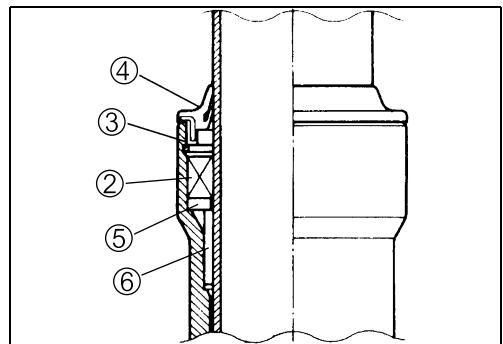

- Install the rebound spring ⑦ on the cylinder ⑧ and install them together to the inner tube.

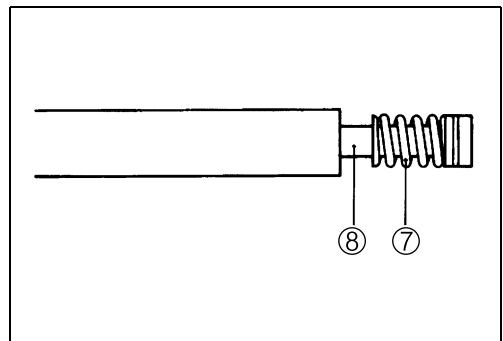

- Tighten the muffler bracket bolts ② to the specified torque.

 **Muffler bracket bolt: 50 N·m (5.0 kgf-m, 36.0 lb-ft)**

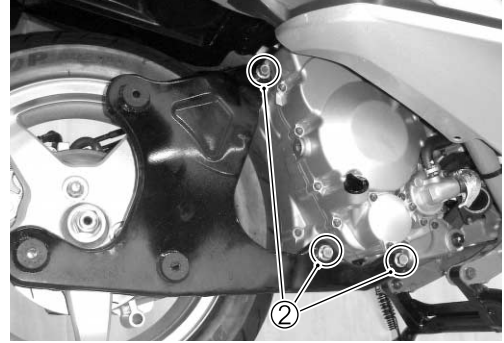

- Insert the bolts from the muffler side and assemble the muffler ③, muffler bracket ④, washers and muffler mounting nuts in that order.
- Tighten the muffler mounting nuts to the specified torque.

 **Muffler mounting nut: 23 N·m (2.3 kgf-m, 16.5 lb-ft)**

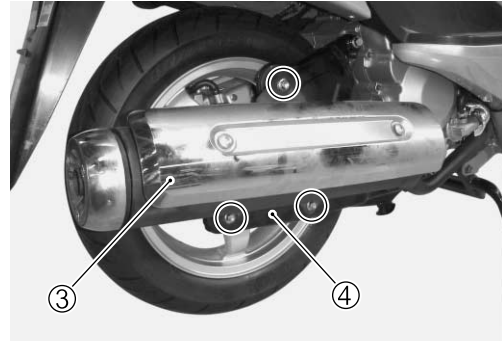

- Tighten the exhaust pipe joint nuts to the specified torque.

 **Exhaust pipe joint nut: 23 N·m (2.3 kgf-m, 16.5-ft)**



MASTER CYLINDER REMOVAL AND DISASSEMBLY

- Remove the handle cover. (➡ 7-11)
- Remove the rear view mirror ①.
- Drain brake fluid from the combination brake reservoir. (➡ 2-18)
- Disconnect the brake light switch lead wires.

- Remove the union bolt ②.

CAUTION

Place a rag under the union bolt so that brake fluid may not contact the parts.

- Remove the master cylinder ③.

- Remove the brake light switch ④ and brake lever ⑤.

- Remove the boot ⑥ and remove the snap ring ⑦.
- Remove the piston/cup set ⑧ and spring ⑨.

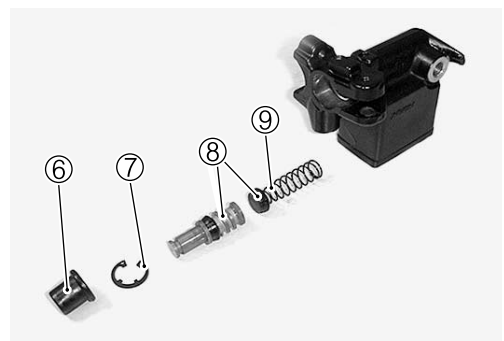
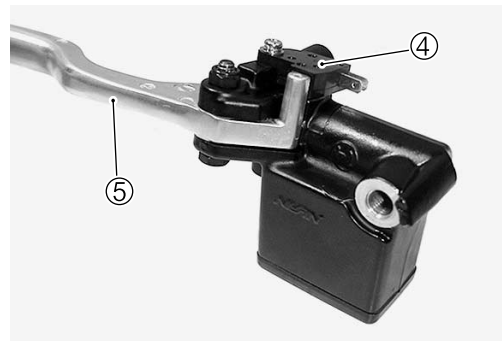
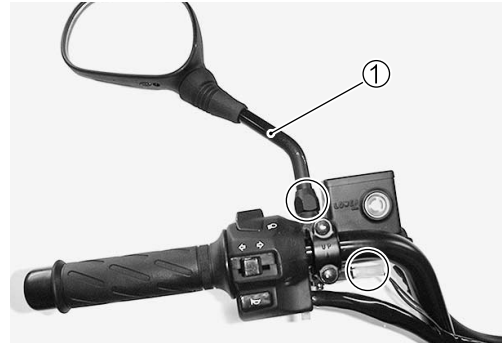

- Disconnect the clamps.

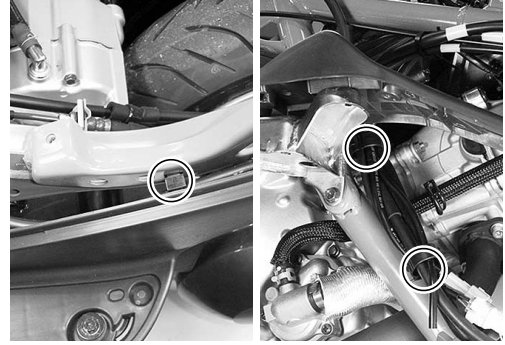

- Remove the rear shock absorber bolt ③, cushion lever mounting nut ④ and rear cushion rod nut ⑤.

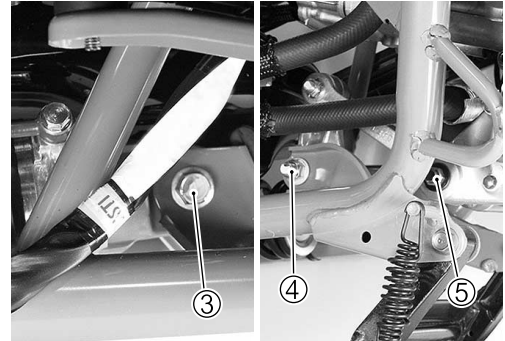

- Remove the cushion lever nuts ⑥, ⑦ and disassemble the rear suspension linkage.

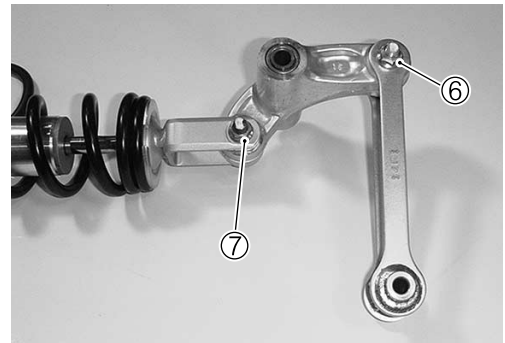

- Remove the cushion lever bearings using the special tools.

TOOL 09930-30104: Sliding shaft
09923-73210: Bearing remover



INSPECTION

CUSHION LEVER

- Inspect the cushion lever body for crack, break or other abnormal condition.
- Attempt to move the spacer laterally to see that no play exists. Also, check the spacer for smooth turning.
- If any abnormal condition is noted in the spacer movement, replace the bearing.



TIRE INSTALLATION

- Apply tire lubricant to the tire bead.
- When installing the tire onto the wheel, observe the following points.

CAUTION

- * Do not reuse the valve which has been once removed.
- * Never use oil, grease or gasoline on the tire bead in place of tire lubricant.

- When installing the tire, the arrow (A) on the side wall should point to the direction of wheel rotation.
- Align the chalk mark put on the tire at the time of removal with the valve position.

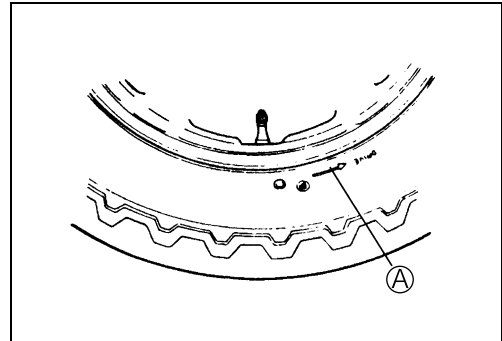
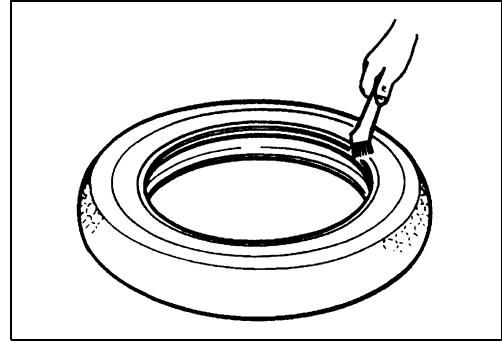

- For installation procedure of tire onto the wheel, follow the instructions given by the tire changer manufacturer.
- Bounce the tire several times while rotating. This makes the tire bead expand outward to contact the wheel, thereby facilitating air inflation.
- Inflate the tire.

⚠ WARNING

- * Do not inflate the tire to more than 400 kPa (4.0 kgf/cm², 57 psi). If inflated beyond this limit, the tire can burst and possibly cause injury. Do not stand directly over the tire while inflating.
- * In the case of preset pressure air inflator, pay special care for the set pressure adjustment.

Step4

1) Measure the continuity of the generator coil. (☞ 8-11)

Is the resistance of generator coil OK?

YES	Go to Step5.
NO	<ul style="list-style-type: none"> • Faulty generator coil. • Disconnected lead wires.

Step5

1) Measure the generator no-load voltage. (☞ 8-11)

Is generator no-load performance OK?

YES	Go to Step6.
NO	Faulty generator.

Step6

1) Inspect the regulator/rectifier. (☞ 8-12)

Is the regulator/rectifier OK?

YES	Go to Step7.
NO	Faulty regulator/rectifier.

Step7

1) Inspect the wire harness.

Is the wire harness OK?

YES	Faulty battery
NO	<ul style="list-style-type: none"> • Short circuit of wire harness. • Poor contact of coupler.

Battery overcharges

- Faulty regulator/rectifier.
- Faulty battery.
- Poor contact of generator lead wire coupler.

SIDE-STAND SWITCH INSPECTION

- Remove the side leg shield. (☞ 7-15)
- Disconnect the side-stand switch coupler ①.
- Measure the voltage between green and Black/White lead wire.

If the resistance is out of specification, replace the switch.

TOOL 09900-25008: Multi-circuit tester set

Tester knob indication: Diode test (←→)

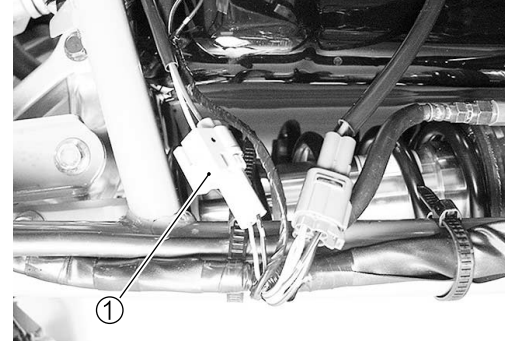

	Green (⊕ probe)	Black/White (⊖ probe)
ON (Side-stand up)	0.4 – 0.6 V	
OFF (Side-stand down)	1.4 V and more (Tester's battery voltage)	

NOTE:

If the tester reads under 1.4 V when the tester probes are not connected, replace its battery.

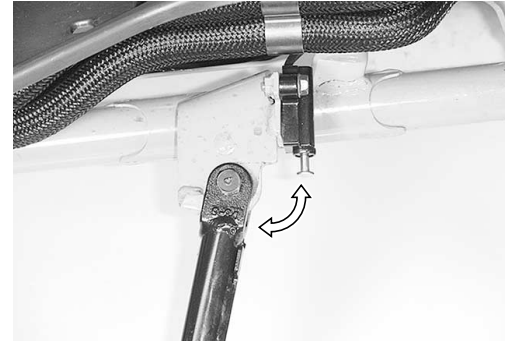
**SAFETY RELAY INSPECTION**

- Remove the front box. (☞ 7-14)
- Remove the safety relay ①.

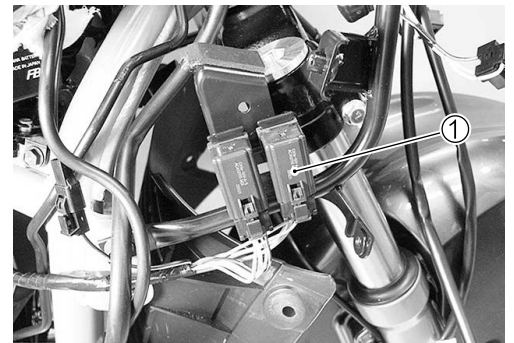

- Check that no continuity exists between the terminals ① and ②. If continuity is found, replace the relay.

TOOL 09900-25008: Multi-circuit tester set

Tester knob indication: Continuity test (••••)

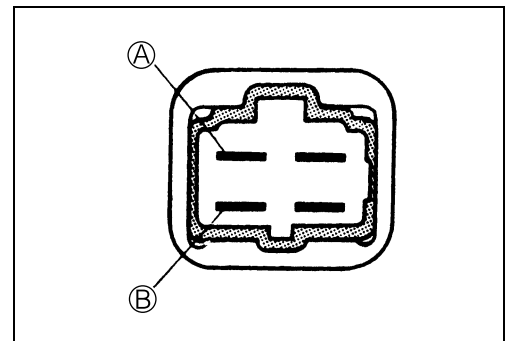

- Check there is continuity between the terminals ① and ② when 12V battery voltage is applied; positive to the terminal ③ and negative to the terminal ④. If no continuity is noted, the relay must be replaced.

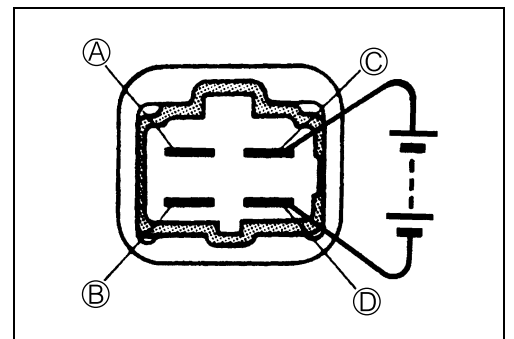

LAMP HEADLIGHT

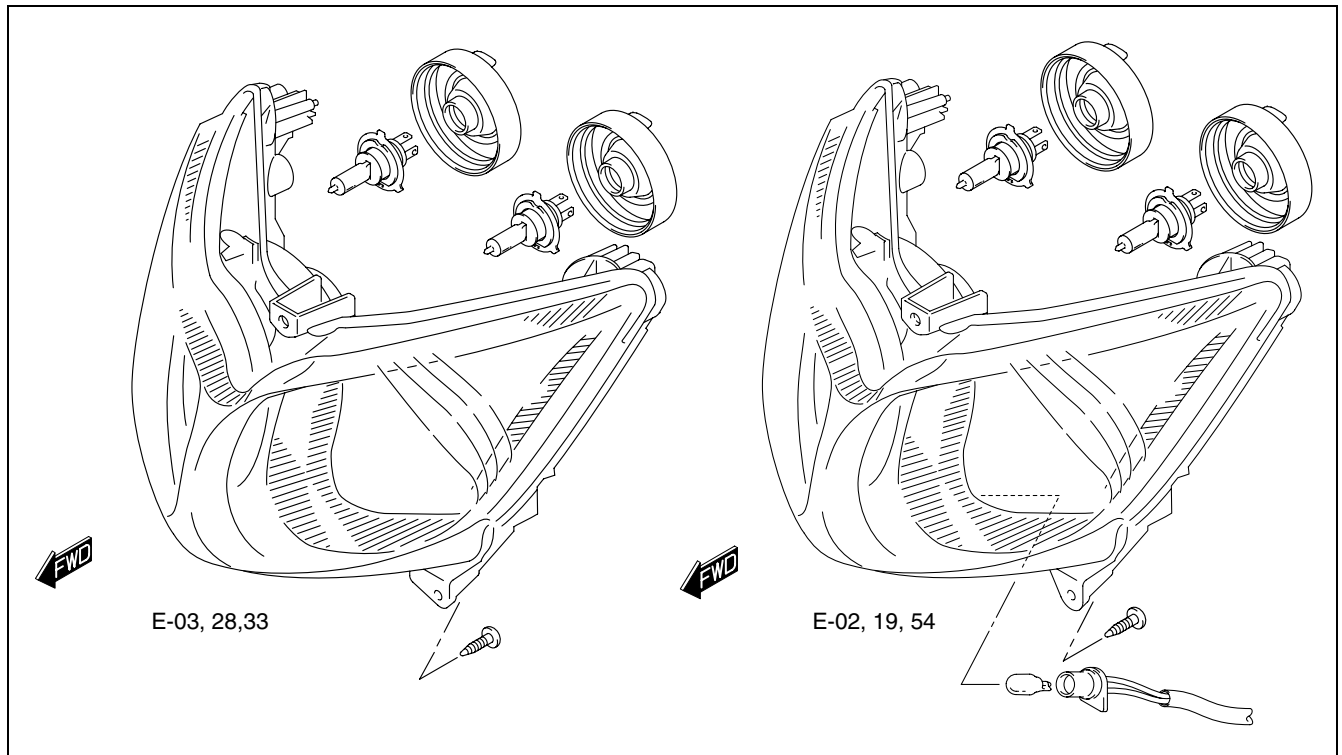

CAUTION

If you touch the bulb with your bare hands, clean the bulb with a cloth moistened with alcohol or soapy water to prevent premature bulb failure.

HEADLIGHT BULB REPLACEMENT

- Disconnect the lead wire couplers.
- Remove the headlight socket cover.
- Remove the headlight bulb ① by releasing the bulb spring ②.
- Install the headlight in the reverse order of removal.

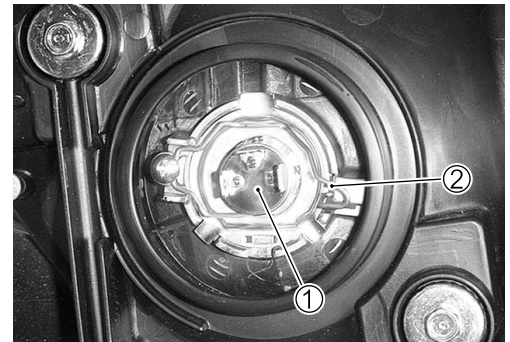





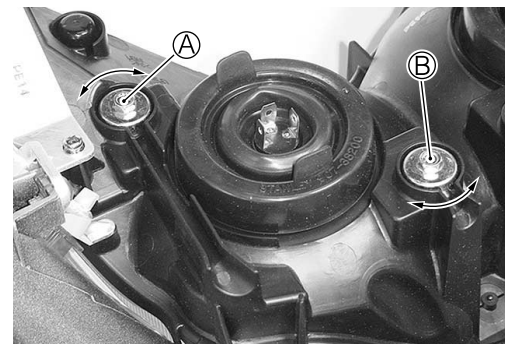





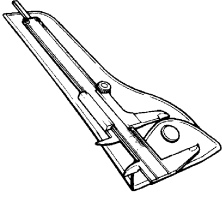
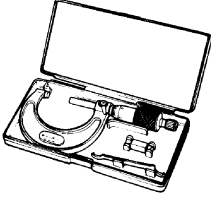
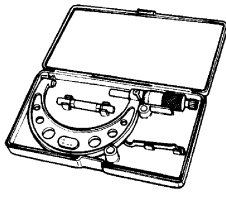
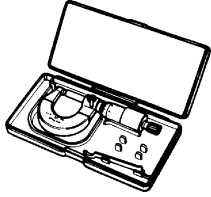
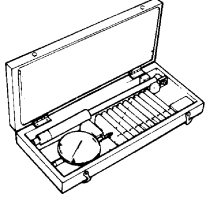
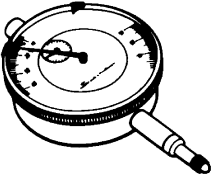
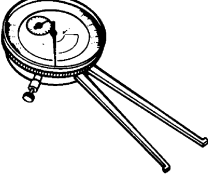
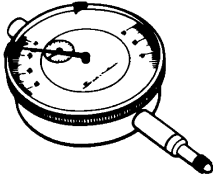

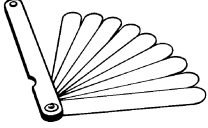
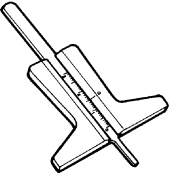
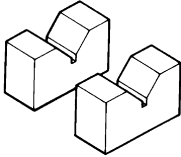
HEADLIGHT BEAM ADJUSTMENT

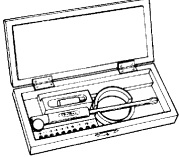
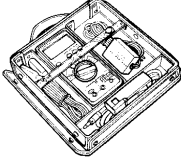
- Adjust the headlight beam, both vertical and horizontal.
- Ⓐ Vertical adjuster (using a screw driver ⊕)
- Ⓑ Horizontal adjuster (using a screw driver ⊕)

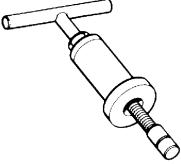

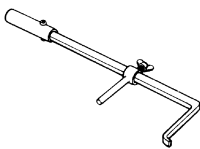
C44	Heated oxygen sensor (HO2S) [E-02,19]	During O2 feedback control, O2 sensor voltage is higher than the specification or lower than the specification. No signal is detected during engine operation, or no electrical power is supplied from battery. HO2S lead wire/coupler connection. Battery voltage supply to the HO2S.
-----	---------------------------------------	---

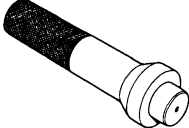
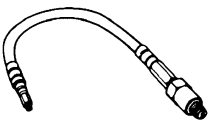
SPECIAL TOOLS

 09900-20102 Vernier calipers	 09900-20202 Micrometer (25 – 50 mm)	 09900-20204 Micrometer (50 – 75 mm)	 09900-20205 Micrometer (0 – 25 mm)	 09900-20508 Cylinder gauge set
 09900-20602 Dial gauge (1/1 000 mm, 1 mm)	 09900-20605 Dial calipers (1/100 mm, 10 – 34 mm)	 09900-20607 Dial gauge (1/100 mm, 10 mm)	 09900-20701 Magnetic stand	 09900-20803/ 09900-20806 Thickness gauge
 09900-20805 Tire depth gauge	 09900-21304 V-block (100 mm)	 09900-22301/ 09900-22302 Plastigauge	 09900-22403 Small bore gauge (18 – 35 mm)	 09900-25008 Multi circuit tester set
 09900-26006 Tachometer	 09910-32812 Crankshaft installer	 09910-32870 Attachment	 09910-60611 Universal clamp wrench	 09913-50121 Oil seal remover
 09913-70210 Bearing installer set	 09913-75830 Bearing installer	 09915-63310 Compression gauge adaptor	 09915-64512 Compression gauge	 09915-74511 Oil pressure gauge

FRONT BRAKE HOSE ROUTING

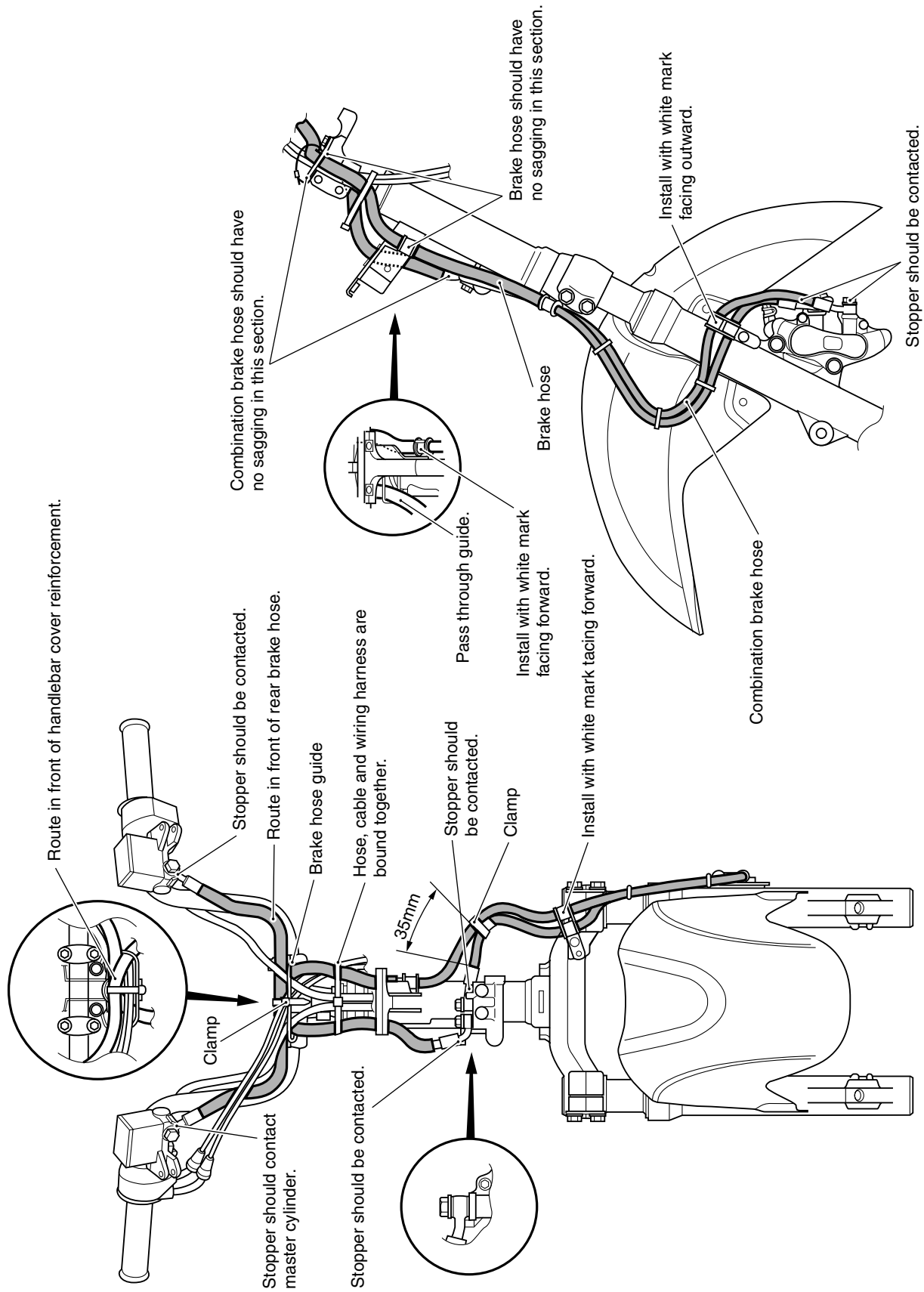

WATTAGE

Unit:W

ITEM		STANDARD/SPECIFICATION	
		E-02,19,54	E03,28,33
Headlight	HI	35 × 2	←
	LO	35 × 2	←
Parking or position light		5 × 2	←
Brake light/Taillight		21/5 × 2	←
Turn signal light		21 × 4	←
License light		5	←
Instrument panel light		1.7 × 3	←
Oil change indicator light		1.7	←
FI indicator light		1.7	←
Brake-lock indicator light		1.7	←
High beam indicator light		1.7	←
Turn signal indicator light		1.7 × 2	←
Trunk light		5	←

CLICK HERE TO **DOWNLOAD** THE COMPLETE MANUAL

- Thank you very much for reading the preview of the manual.
- You can download the complete manual from: www.heydownloads.com by clicking the link below



- Please note: If there is no response to CLICKING the link, please download this PDF first and then click on it.

CLICK HERE TO **DOWNLOAD** THE COMPLETE MANUAL