



## Workshop literature

## Tow tractor

LTX 70  
LTX 80  
LTX-T08



0608 0609 0610  
11918012101 EN - 11/2016

first in intralogistics



CLICK HERE TO **DOWNLOAD** THE COMPLETE MANUAL

- Thank you very much for reading the preview of the manual.
- You can download the complete manual from: [www.heydownloads.com](http://www.heydownloads.com) by clicking the link below



- Please note: If there is no response to CLICKING the link, please download this PDF first and then click on it.

CLICK HERE TO **DOWNLOAD** THE COMPLETE MANUAL

**⚠ DANGER**

**Never step under an elevated load.**

When lifting the tractor, make sure that no one is in the vicinity.

---

## CAN box diagnostics

### CAN box, serial

The serial CAN box is equipped with a 4-pin round plug (1) on the left-hand side that is connected to the truck diagnostic connector.

A 9-pin Sub-D plug (5) is provided on the right-hand side. This plug is connected to the notebook.

A reset button (6) for restarting the CAN box is fitted on the left-hand side.



### CAN box, USB

The USB CAN box is equipped with three connections on the left-hand side. The top connection is a 4-pin round connector (1), which is connected to the diagnostic connector on the truck. The bottom connection is a USB cable (8), which is connected to the notebook. The centre connection is not currently used.



### LED displays

Three LEDs indicate the communication status of the CAN box:

- The LED (2) lights up once the CAN box is supplied with voltage via the diagnostic connector when the truck is switched on
- The LED (4) indicates the status between the notebook and the CAN box
- The LED (3) indicates the status between the CAN box (CAN 1) and the truck
- The LED (7) indicates the status between the CAN box (CAN 2) and the truck. This LED is not used.
- Applies only to the USB CAN box:  
If all of the LEDs (2,3,4,7) are flashing, the CAN box is in programming mode. In this case, the CAN box must be restarted.

### Resetting the CAN box

Switching the truck off and on again will trigger a reset of the CAN box. The supply to the CAN bus is interrupted when the truck is switched off.

**Exception:** RX50 (5060-5066): The CAN box must be disconnected from the truck (diagnostic connector) in order to be reset. It is not sufficient to switch off the truck.

Shock absorbers

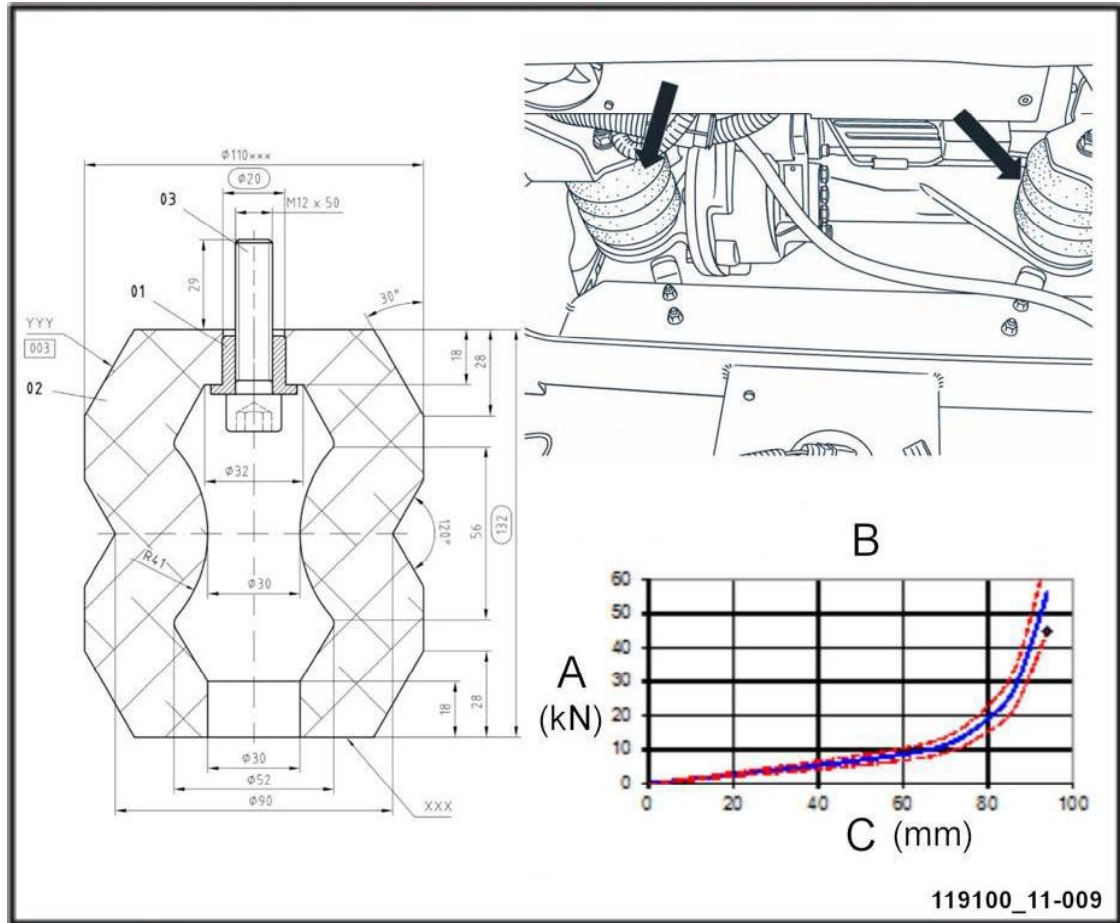

- A Force
- B Characteristic curve
- C Distance

- 01 Force measurement
- 02 Distance measurement
- 03 Rigidity measurement

Test specifications

Load	Diameter ( $\pm 20\%$ )
320 kg	119.5 mm
900 kg	136 mm

Adjustment speed: 20 mm/min

Load adjustment up to: 56 kN

## Cleaning the motor

To ensure adequate cooling of the electric motors, the drive axle must be cleaned at the specified inspection and maintenance intervals.

The outside of the drive axle can be cleaned thoroughly. The best cleaning agent is **oil-free** compressed air. If the outside of the axle housing is very heavily soiled, a high-pressure cleaner can be used. However, depending on the level of contamination, it is recommended that the air ducts and power modules are removed. Special care should be taken to ensure that the spaces between the cooling fins on the motor are free from contamination, so as to ensure correct cooling of the motor. Only water may be used for this. Under no circumstances should chemical cleaning agents be added when using a high-pressure cleaner. Chemical cleaning additives may attack the plastic parts of the motor. Sufficient distance must be maintained between the jet lance and the motor.



### NOTE

*After disassembly of the motor connections, the electrical contact surfaces should be cleaned thoroughly before reassembly to avoid damage and error messages due to excessive contact resistance.*

Intensive cleaning with a high-pressure cleaner should be avoided around the motor connections. No moisture should be allowed to enter the motor. If despite all precautions, moisture does penetrate the motor, the truck must be driven for

an extended period to avoid corrosion damage (drying through heat generated by truck), or the motors must be dried using a heat source (hot-air blower or heating system).

A motor that has been dismantled must **not** be cleaned with a high-pressure cleaner in the area around the stator. Do **not** use compressed air for cleaning, as compressed air may contain oil or moisture. Firstly, any large particles of electrically conductive foreign matter should be removed by suction. Dust and grease should then be removed from the stator using a cloth and a solvent that will remove oxides and sulphides as well as gummed oils and greases. A final cleaning of the stator should be carried out with an electric cleaning material (e.g. S.L.X. electric cleaner – [www.rivolta.de](http://www.rivolta.de)). These electric cleaning materials have a dielectric strength of up to 100,000 V/cm and are free from hydrocarbons such as CHCs, CFCs, aromatics, PCB/PCTs and other pollutants. This allows all dirt to be rinsed thoroughly from the windings. After rinsing, the stator must be dried with a hot-air blower. Here it must be ensured that the blower temperature does not exceed 150 °C or the finish on the windings may be irreparably damaged.

The rotor can be cleaned with conventional cleaning methods .

- PCB – polychlorinated biphenyls
- PCT – polychlorinated terphenyls
- CHCs – chlorinated hydrocarbons
- CFCs – chlorofluorocarbons

**Removing the windscreen wiper motor**

- Disconnect the plug from the windscreen wiper motor (6).
- Place a container under the windscreen wiper motor (7).
- Disconnect the hose from the windscreen wiper motor (8).
- Remove the windscreen wiper motor from the tank (9).

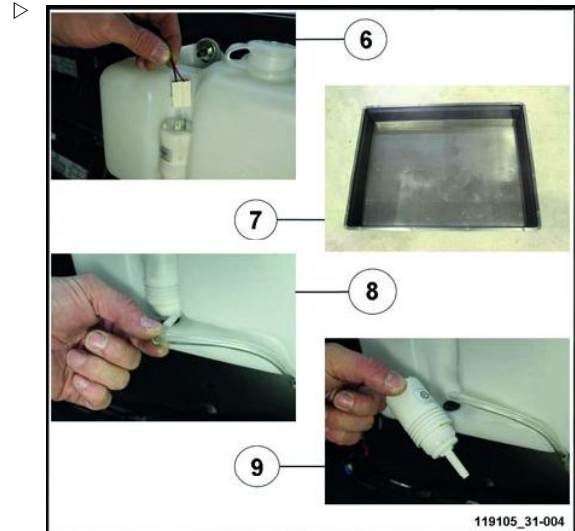
**Installing the windscreen wiper motor**

- Take a new windscreen wiper motor (10).
- Place the new motor on the tank (11).
- Connect the hose to the motor (12).
- Remove the container (13).
- Connect the plug of the windscreen wiper motor (14).
- Refit the rear cover in the cab (15).
- Insert the two screws (16).
- Position the driver's seat (17).

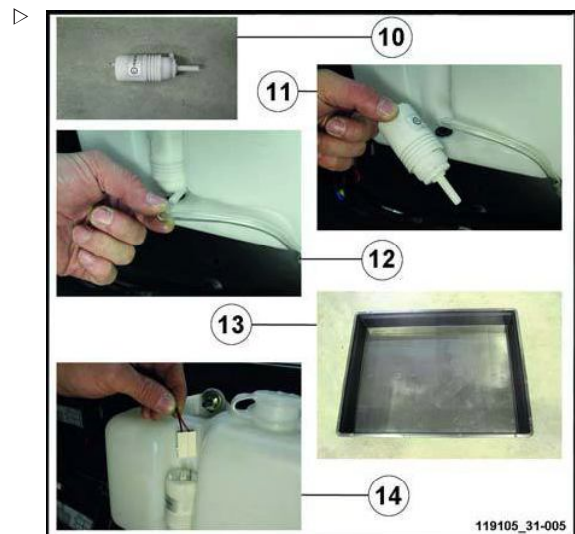

- Open the cover of the tank (18).
- Fill the water tank (19).
- Carry out a functional test.

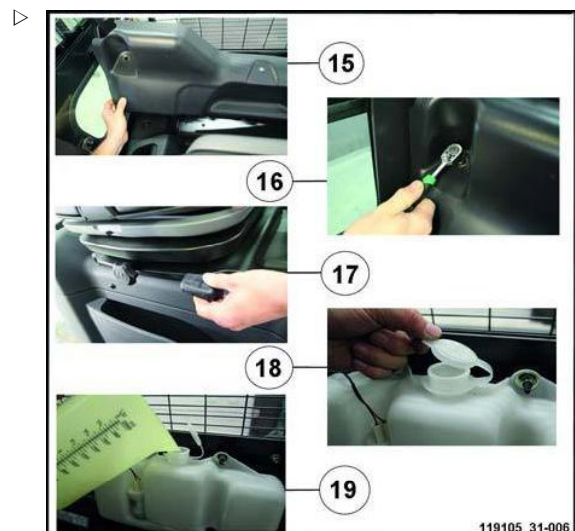

## Changing the accelerator

### Preparing the truck

- Immobilise the truck.
- Switch off the ignition and remove the key.
- Pull the emergency off switch.
- Open the battery compartment door (1).
- Disconnect the battery connector (2).
- Remove the floor mat (3).

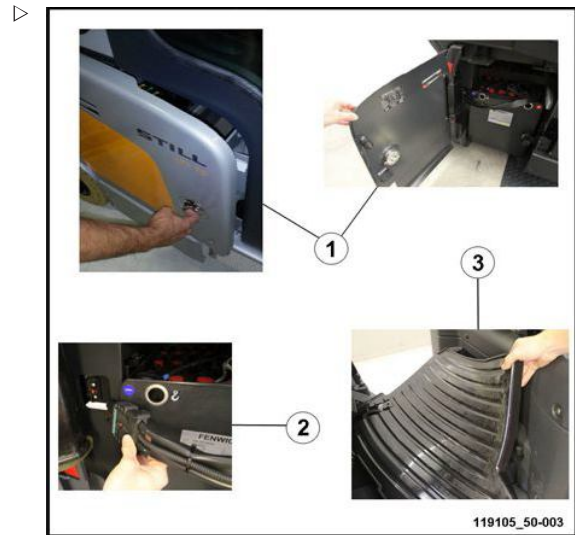

### Raising the truck

- Raise the front of the truck using a hydraulic jack (4).
- Place axle stands under the truck (5).

#### ⚠ CAUTION

Risk of injury

Ensure that the hydraulic cylinder of the jack is in the correct position.

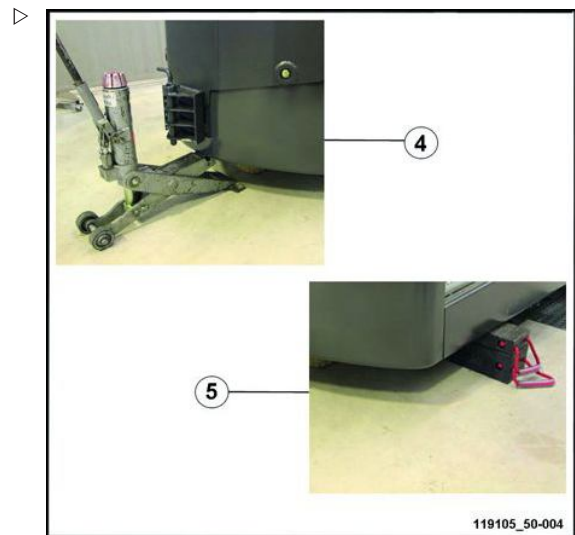

CLICK HERE TO **DOWNLOAD** THE COMPLETE MANUAL

- Thank you very much for reading the preview of the manual.
- You can download the complete manual from: [www.heydownloads.com](http://www.heydownloads.com) by clicking the link below



- Please note: If there is no response to CLICKING the link, please download this PDF first and then click on it.

CLICK HERE TO **DOWNLOAD** THE COMPLETE MANUAL

### Installing the brake drum

- Place the brake drum on the truck (21).
- Lubricate the inner ring of the tapered roller bearing (22).

#### ▲ WARNING

Risk of injury  
Wear protective equipment

#### ▲ CAUTION

Risk of damage  
Use the consumables specified.

- Place the inner ring in the brake drum (23).
- Position the washer (24).
- Tighten the hexagon nut (tightening torque: 185 Nm) (25).
- Lubricate (26) and position the hubcap (27).
- Position the brake shoe (28).
- Refit the wheel (29).
- Refit the wheel bolts (30).
- Carry out a functional test.
- Remove the axle stands.
- Tighten the wheel bolts (tightening torque: 195 Nm) (31).
- Carry out a test drive.

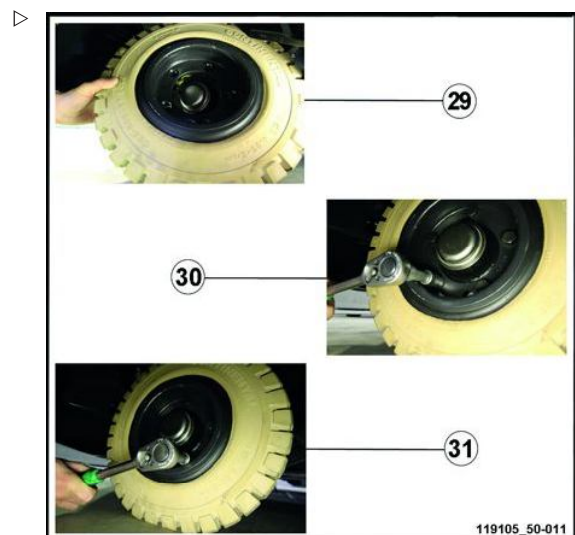
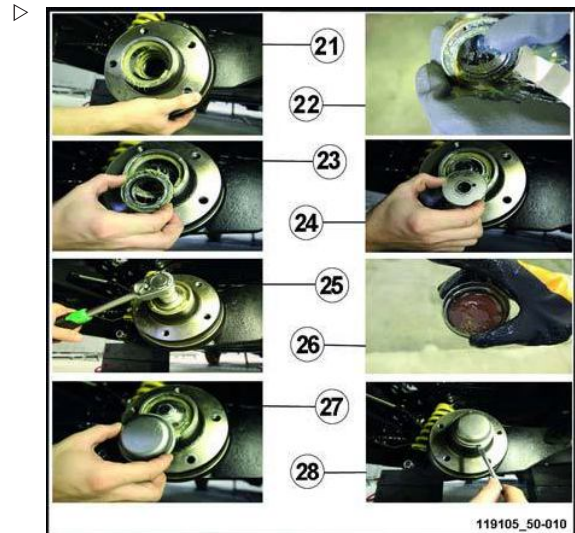



## Electric components

### Emergency off switch

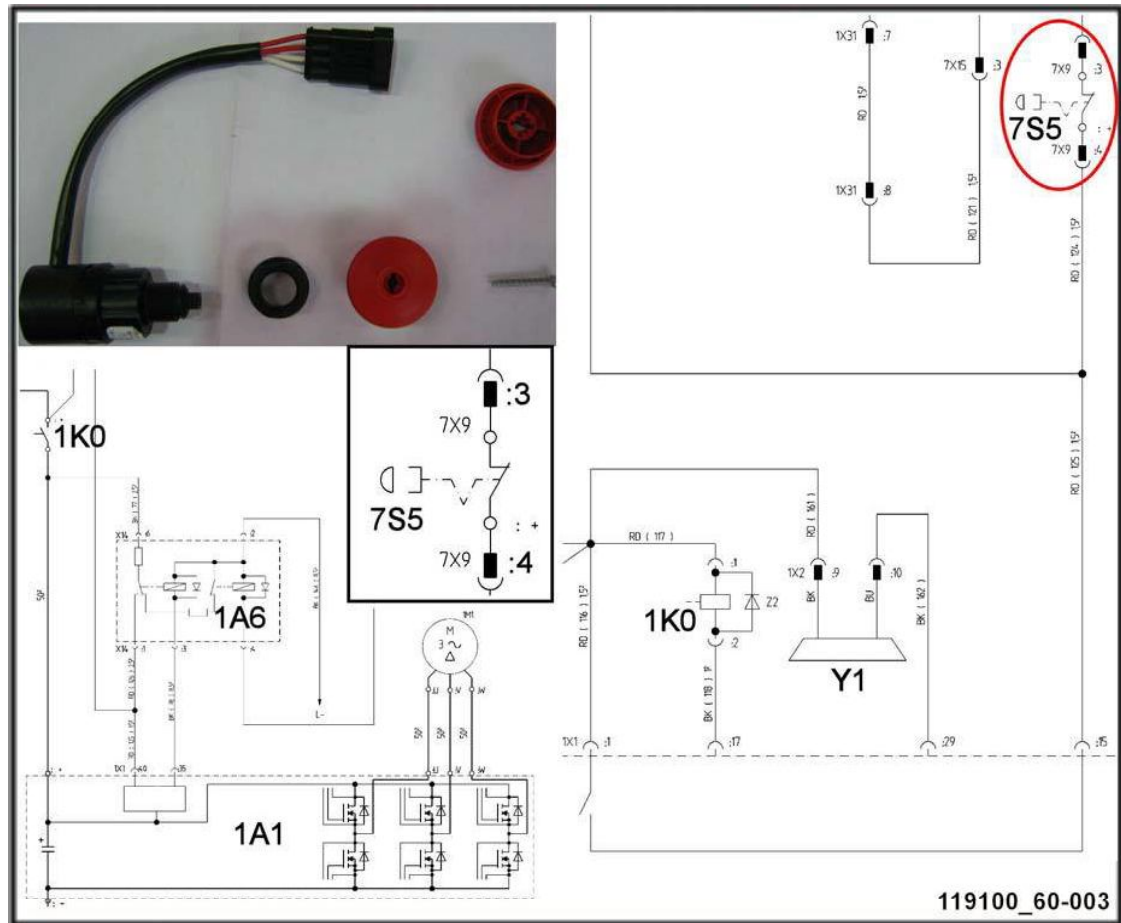

The standard version of the truck is equipped with an emergency off switch 7S5 positioned to the right of the driver.

When it is activated, it cuts off the controller LAC, the safety relay and the switch coil 1K0 at the same time.

It activates the electromagnetic brake Y1 (braking by lack of current) and cuts off the truck traction.

In addition, it cuts off the power supply to the pre-charging circuit 1A6.

**i** NOTE

*There are two emergency off switches (7S5 and 7S8) on each side of the truck for the slow travel option (pedestrian).*

**i** NOTE

*There are two emergency off switches (7S9 and 7S10) at the rear of the truck for the inching mode option (inching).*

#### Pin assignments for connector 7X9

Pin	Function
7X9: 1	Normally open contact (not used)
7X9: 2	Normally open contact (not used)
7X9: 3	Normally closed contact
7X9: 4	Normally closed contact

## Maintenance interval indicator

When the key switch is switched on, the display shows the hours of use (1) until the next service.

The number of kilometres left to run (2) and the total number of kilometres travelled by the truck are shown (4).

The hours of use until the next service are counted down synchronously with the operating hours.

The maintenance interval time is set to 1000 operating hours and can be adjusted using the diagnostic tool.

When the counter for the maintenance interval time reaches zero, the symbol (3) is activated when the truck is started up.

The display shows the time exceeded as a negative value (5).

The symbol (3) will flash when the truck starts if the set maintenance time has been exceeded. The service interval counter can be reset using the diagnostic tool.

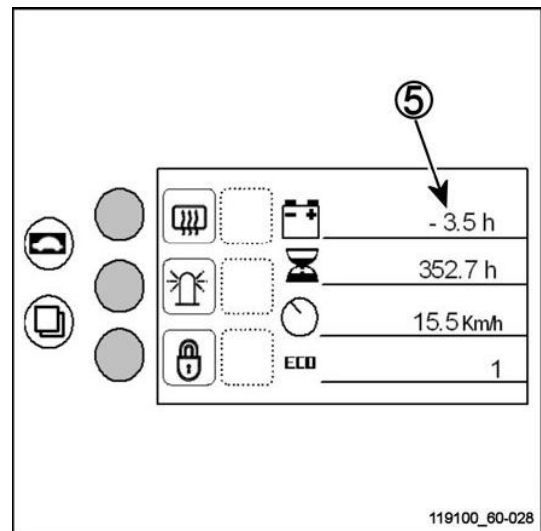
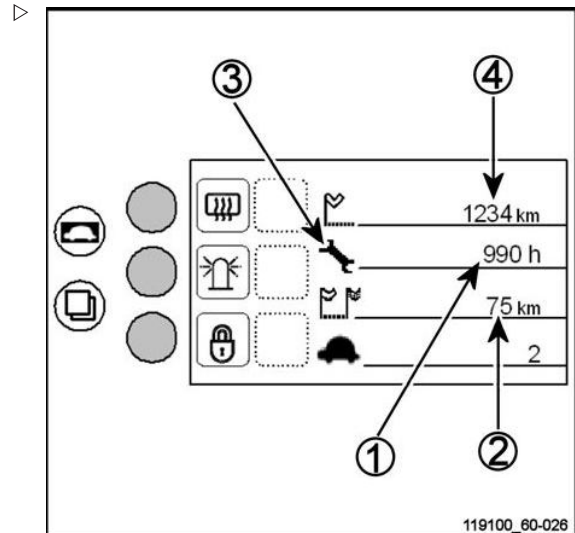

## Access control

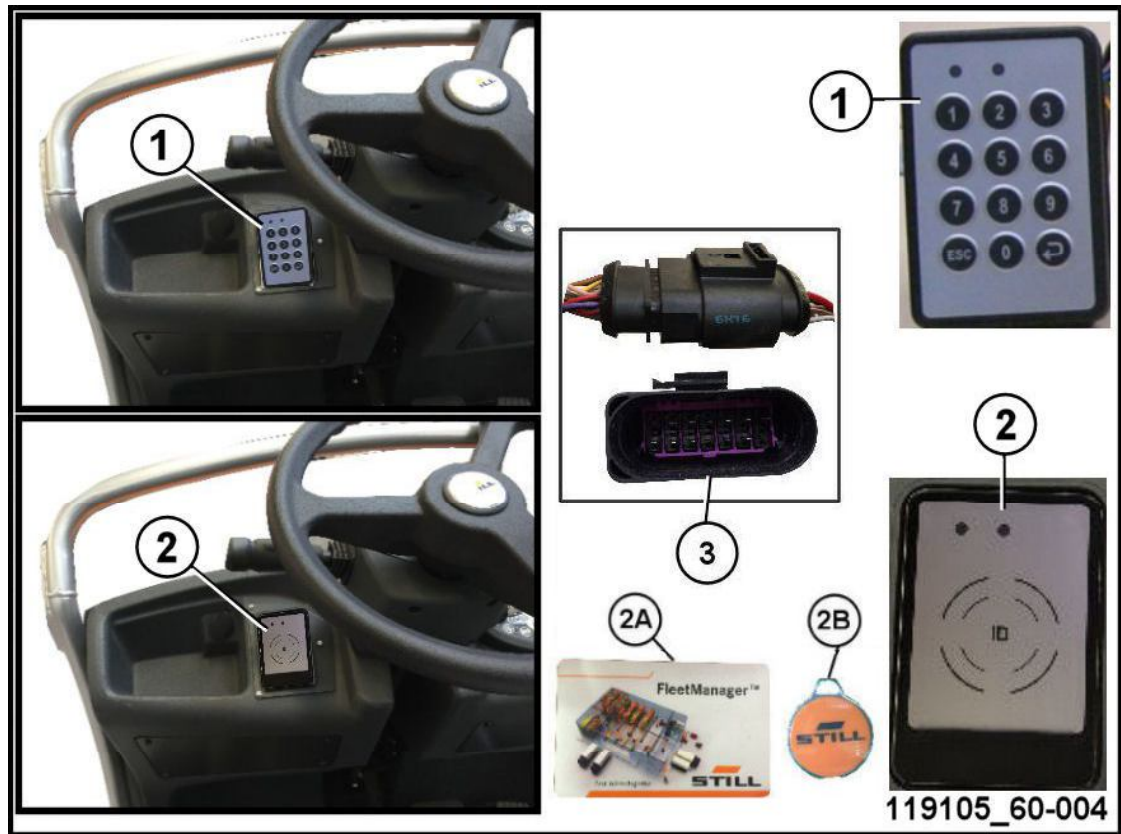

- 1 Reading device with a keypad
- 2 RFID reading device\*
- 2A RFID transponder card
- 2B RFID transponder
- 3 TDU connector 6X16

The TDU (Truck Data Unit) access control is available in two versions:

- Reading device with a keypad (1) OR
- RFID (Radio Frequency Identification) reading device with truck access by:
  - ▶ RFID transponder card, 13.56 MHz (2A)
  - ▶ RFID transponder, 13.56 MHz (2B)

Some of the data is transferred via Bluetooth.

Parameterising is carried out with the **Service Base** of the After-Sales Service.

\*Contact the After-Sales Service to obtain the following versions of transponders:

- RFID transponder, 125 kHz
- RFID transponder card, 125 kHz

**i** NOTE

*The only way to find out the access control version is by connecting it.*

Assignments of connector 6X16(3)	
6X16: 1	Battery voltage
6X16: 3	0 V
6X16: 5	Shock signal
6X16: 7	Relay 1
6X16: 8	Relay 1
6X16: 11	CAN 2 High
6X16: 12	CAN 2 Low
6X16: 13	CAN 1 High
6X16: 14	CAN 1 Low

## Lifrunner (option)

## Features

## Exploded view

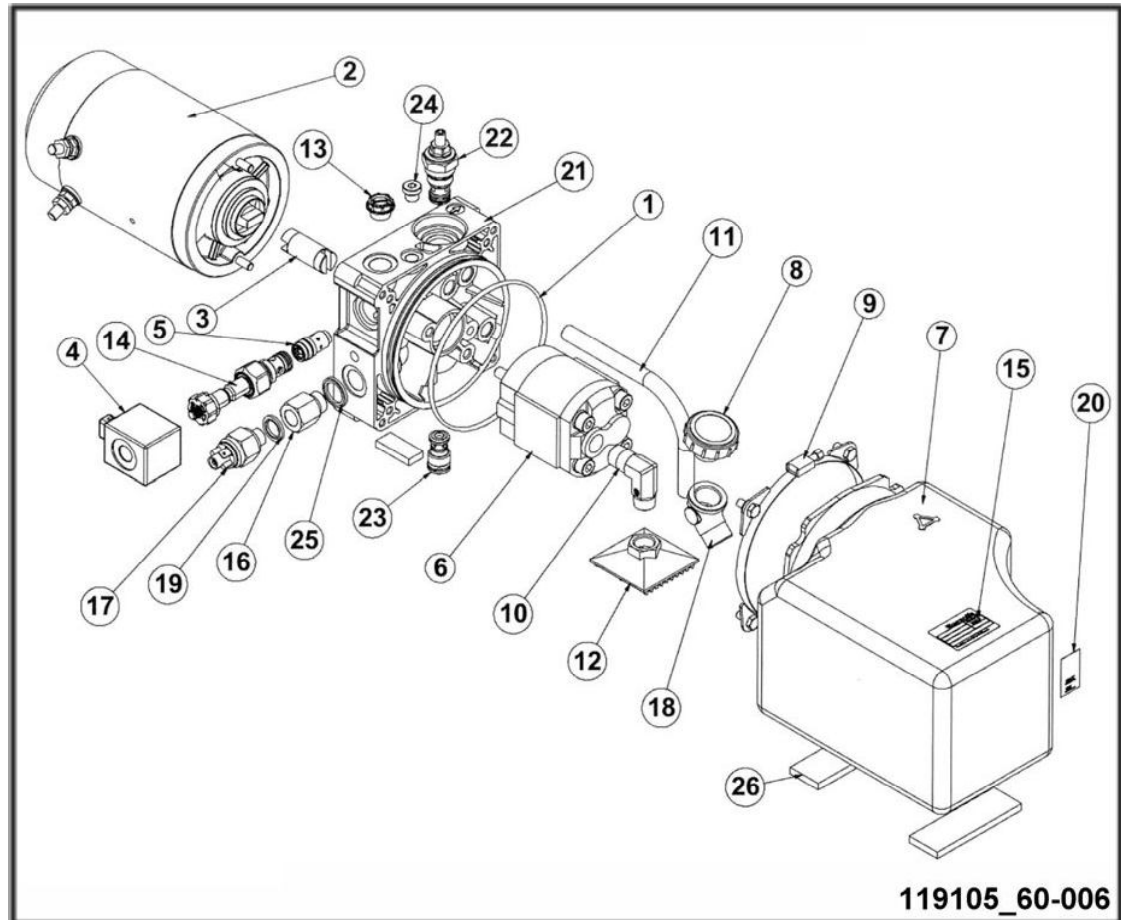

1	O-ring	14	Valve
2	Pump motor	15	Tank label
3	Coupling	16	'3/8-1/4-BSPP adaptor
4	Coil	17	Manostat
5	Flow limiter	18	Adaptor
6	Pump	19	Seal
7	Tank	20	Min./max. oil level label
8	Plug	21	Valve holder
9	Fasteners	22	Pressure cut-off
10	Pipe	23	Non-return valve
11	Pipe	24	Screw plug 'G1/8-V80-A3C
12	Suction filter	25	'3/8 seal
13	Sealing plug	26	Seal

**▲ WARNING**

Risk of pinching of the cables

Take care not to pinch the battery connector cable.

- Lock the battery.
- Reconnect the battery connector.
- Close the battery compartment door.
- Restart the truck.

CLICK HERE TO **DOWNLOAD** THE COMPLETE MANUAL

- Thank you very much for reading the preview of the manual.
- You can download the complete manual from: [www.heydownloads.com](http://www.heydownloads.com) by clicking the link below



- Please note: If there is no response to CLICKING the link, please download this PDF first and then click on it.

CLICK HERE TO **DOWNLOAD** THE COMPLETE MANUAL