



Workshop Manual

Service Procedures

Werkplaatshandboek

Onderhoudsprocedures

Manual d'Atelier

Procédures de service

Werkstatthandbuch

Wartungsanleitungen

Manuale d'Officina

Procedure di servizio

Manual de Taller

Procedimientos de servicio

Manual de Oficina

Processos de Serviço



CLICK HERE TO **DOWNLOAD** THE COMPLETE MANUAL

- Thank you very much for reading the preview of the manual.
- You can download the complete manual from: www.heydownloads.com by clicking the link below



- Please note: If there is no response to CLICKING the link, please download this PDF first and then click on it.

CLICK HERE TO **DOWNLOAD** THE COMPLETE MANUAL

CONTENTS

Sensor - heated oxygen (H02S) - post cat - front - KV6	19-2-16
Sensor - heated oxygen (H02S) - post cat - front - K1.8	19-2-17
Filter - main	19-2-18
Pump - fuel	19-2-19
Tank	19-2-20
Filler neck	19-2-22
Fuel rail - KV6	19-2-23
Injector - KV6	19-2-25
Injectors - set - K1.8	19-2-25
Actuator unit - cruise control - KV6	19-2-27
Vacuum pump - cruise control - KV6	19-2-27
Switch - cruise control - KV6	19-2-28
ECU - cruise control - KV6	19-2-29
Interface ECU - cruise control - KV6	19-2-29

COOLING SYSTEM - Td4 26-1-1

ADJUSTMENTS

Coolant - drain and refill	26-1-1
----------------------------	--------

REPAIRS

Cooling fan and motor	26-1-3
Radiator assembly	26-1-4
Coolant pump and thermostat	26-1-6

COOLING SYSTEM - K SERIES 1.8 26-2-1

ADJUSTMENTS

Coolant - drain & refill	26-2-1
Coolant - refill system	26-2-2

REPAIRS

Tank - expansion	26-2-3
Cooling fan and motor - non A/C	26-2-3
Cooling fan and motor - A/C	26-2-4
Control unit - radiator cooling fan	26-2-6
Radiator assembly	26-2-6

COOLING SYSTEM - K SERIES KV6 26-3-1

ADJUSTMENTS

Coolant - drain and refill	26-3-1
----------------------------	--------

REPAIRS

Cooling fan and motor	26-3-3
Radiator assembly	26-3-3
Thermostat	26-3-5
Coolant pump	26-3-6

CONTENTS

PAINTING	77-5-1
PANEL PROCEDURES	
Panel Preparation	77-5-1
PAINT PROCEDURES	
Paint preparation	77-5-3
HEATING AND VENTILATION	80-1
REPAIRS	
Controls - heater	80-1
Servo - air recirculation	80-2
Switch - recirculation control	80-2
Switch - fan - front heater	80-3
Ventilator - face level - LH	80-4
Plenum - air intake	80-4
Heater unit	80-5
Blower assembly	80-7
Resistor unit - fan motor	80-8
Matrix - heater	80-8
Fuel burning heater (FBH)	80-9
Sensor - outside temperature (OT)	80-10
Fuel pump - fuel burning heater	80-11
AIR CONDITIONING	82-1
REFRIGERANT RECOVERY, RECYCLING AND RECHARGING	
Refrigerant recovery - recycling and recharge	82-1
ADJUSTMENTS	
Drive belt - compressor - Td4	82-3
REPAIRS	
Drive belt - compressor - Td4	82-5
Compressor - Td4	82-5
Compressor - KV6	82-6
Compressor - K1.8	82-8
Condenser	82-9
Receiver drier	82-11
Switch - control	82-12
Sensor - refrigerant pressure	82-12
Valve - thermostatic expansion (TXV)	82-13



General precautions

Dangerous substances

Modern vehicles contain many materials and liquids which if not handled with care can be hazardous to both personal health and the environment.

WARNING: *Many liquids and other substances used in motor vehicles are poisonous and should under no circumstances be consumed and should, as far as possible, be kept from contact with the skin. These liquids and substances include acid, anti-freeze, asbestos, brake fluid, fuel, windscreen washer additives, lubricants, refrigerants and various adhesives.*

Always read carefully the instructions printed on labels or stamped on components and obey them implicitly. Such instructions are included for reasons of your health and personal safety. Never disregard them.

WARNING: *Many of the fluids used in motor vehicles, such as coolant, brake fluid and power steering fluid, are inflammable. Take care not to spill fluids when topping-up, a fire may result. If spillage does occur, ensure the area is thoroughly cleaned before starting the engine.*

Synthetic rubber

Many 'O' rings, seals, hoses, flexible pipes and other similar items which appear to be natural rubber, are in fact, made of synthetic materials called Fluoroelastomers.

Under normal operating conditions this material is safe and does not present a health hazard. However, if the material is damaged by fire or excessive heating, it can break down and produce highly corrosive Hydrofluoric acid which can cause serious burns on contact with skin.

If skin contact does occur:

- Remove any contaminated clothing immediately.
- Irrigate affected area of skin with a copious amount of cold water or limewater for 15 to 60 minutes.
- Obtain medical assistance immediately.

Should any material be in a burnt or over-heated condition, handle with extreme caution and wear protective clothing (seamless industrial gloves, protective apron etc.). Decontaminate and dispose of gloves immediately after use.

Lubricating oils

WARNING: Avoid excessive skin contact with used engine oil. Used engine oil contains potentially harmful contaminants which may cause skin cancer or other serious skin disorders.

WARNING: Avoid excessive skin contact with mineral oil. Mineral oils remove the natural fats from the skin, leading to dryness, irritation and dermatitis.

Health protection precautions

The following precautions should be observed at all times:

- Avoid prolonged and repeated contact with oils, particularly used engine oils.
- Wear protective clothing, including impervious gloves where practicable.
- Do not put oily rags in pockets.
- Avoid contaminating clothes (particularly those next to the skin) with oil.
- Overalls must be cleaned regularly. Discard heavily soiled clothing and oil impregnated footwear.
- First aid treatment should be obtained immediately for open cuts and wounds.
- Use barrier creams: apply before each work period to help prevent lubricating oil from contaminating the skin.
- Wash with soap and water to ensure all oil is removed (proprietary skin cleansers and nail brushes will help).
- Use moisturisers after cleaning; preparations containing lanolin help replace the skin's natural oils which have been removed.
- Do not use petrol, kerosene, diesel fuel, gas, oil, thinners or solvents for cleaning skin.
- If skin disorders develop, obtain medical advice without delay.
- Where practicable, degrease components prior to handling.
- Wear eye protection (e.g. goggles or face shield) if there is a risk of eye contamination. Eye wash facilities should be provided in the close vicinity of the work area.

GENERAL INFORMATION

Bolt identification

Bolt identification

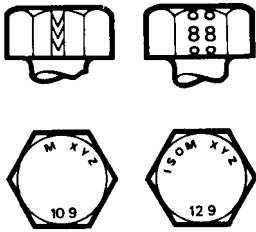

M01 0180

An ISO metric bolt or screw made of steel and larger than 6 mm in diameter can be identified by either the symbols ISO M or M embossed or indented on top of the bolt head.

In addition to marks identifying the manufacturer, the top of the bolt head is also marked with symbols indicating the strength grade, e.g. 8.8; 10.9; 12.9; 14.9. As an alternative, some bolts and screws have the M and strength grade symbol stamped on the flats of the hexagon.

Encapsulated bolts and screws



M01 0181

Encapsulated bolts and screws have a micro-encapsulated locking agent pre-applied to the thread. They are identified by a coloured section which extends 360° around the thread. The locking agent is released and activated by the assembly process and is then chemically cured to provide the locking action.

Unless a specific repair procedure states otherwise, encapsulated bolts may be re-used providing the threads are undamaged and the following procedure is adopted:

- Remove loose adhesive from the bolt and housing threads.
- Ensure threads are clean and free of oil and grease.
- Apply an approved locking agent.

An encapsulated bolt may be replaced with a bolt of equivalent specification provided it is treated with an approved locking agent.



SRS Harnesses and Connectors

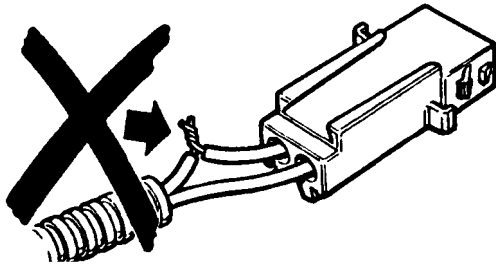

M01 0190

CAUTION: Always observe the following precautions with regards to SRS system electrical wiring:

- Never attempt to modify, splice or repair SRS wiring.
- Never install electronic equipment (such as a mobile telephone, two-way radio or in-car entertainment system) in such a way that it could generate electrical interference in the airbag harness. Seek specialist advice when installing such equipment.

NOTE: SRS system wiring can be identified by a special yellow outer sleeve protecting the wires (black with yellow stripe protective coverings are sometimes used).

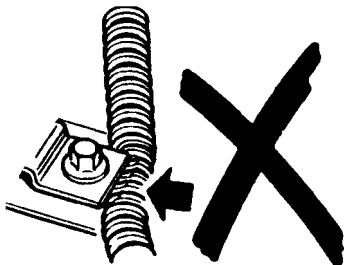

M01 0191

WARNING: Always ensure SRS wiring is routed correctly. Be careful to avoid trapping or pinching the SRS wiring. Do not leave the connectors hanging loose or allow SRS components to hang from their harnesses. Look for possible points of chafing.

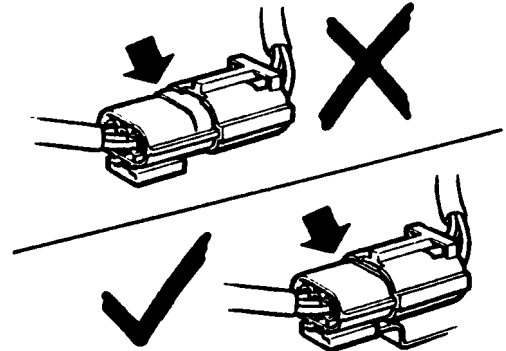

M01 0192

CAUTION: Ensure all SRS harness connectors are mated correctly and securely fastened. Do not leave the connectors hanging loose.

Rotary Coupler

CAUTION: Always follow the procedure for fitting and checking the rotary coupler as instructed in the SRS repairs section. Comply with all safety and installation procedures to ensure the system functions correctly. Observe the following precautions:

- Do not install a rotary coupler if it is suspected to be defective.
- Do not attempt to service, modify or repair a rotary coupler.
- Do not cut, splice or modify the wires attached to the rotary coupler.
- Always ensure the rotary coupler connectors are mated correctly and securely fastened.
- Always ensure the battery is disconnected before working on the rotary coupler.
- Do not unlock and rotate the rotary coupler when it is removed from the vehicle.
- Do not turn the road wheels when the rotary coupler is removed from the vehicle.
- Always ensure the rotary coupler is removed and installed in its centred position and with the front road wheels in the straight ahead position - refer to the SRS repair section for the correct removal and installation procedure.
- If a new rotary coupler is being installed, ensure the locking tab holding the coupler's rotational position is not broken; units with a broken locking tab should not be used.

GENERAL DATA

Valves	
Stem diameter:	
⇒ Inlet	5.97 ± 0.01 mm (0.235 ± 0.0004 in.)
⇒ Exhaust	5.97 ± 0.01 mm (0.235 ± 0.0004 in.)
Valve stem to guide clearance	0.025 - 0.054 mm (0.0010 - 0.0021 in.)
Valve head stand down:	
⇒ Inlet	0.73 ± 0.1 mm (0.029 ± 0.004 in.)
⇒ Exhaust	0.56 ± 0.1 mm (0.022 ± 0.004 in.)
Head diameter	25.9 ± 0.1 mm (1.02 ± 0.004 in.)
Valve seat angle:	45°
Valve seat width:	
⇒ Inlet	1.20 ± 0.15 mm (0.047 ± 0.006 in.)
⇒ Exhaust	1.45 ± 0.15 mm (0.057 ± 0.006 in.)
Valve springs	
Type	Parallel, single coil
Free length	47.5 mm (1.87 in.)
Fitted length	32 mm (1.26 in.)



Fuel system – K1.8 petrol

System	Returnless multi-point fuel injection electronically controlled by Motorola MEMS 3, ECM, with electro-mechanical fuel injectors
Fuel specification	EN228, 95 unleaded*
Fuel rail	Single nylon moulding with integral pressure damper
Injectors	4 x Bosch EV6E - MYJ 100550; air assisted, split stream targeted onto back of inlet valves
Injector flow rate	117 g/min. @ 300 kPa (3.0 bar, 43.5 lbf.in ²)
Fuel pump	Continuous flow, electrically driven roller vane pump submerged in fuel tank
Fuel pressures	3.5 bar, 50.7 lbf.in ²)
Fuel pressure regulation	Controlled by in-tank pressure regulator
Fuel pump delivery	39 litres @ 300 kPa (43.5 lbf.in ²)
Fuel filter	In-tank, lifetime fit, Mesh area 584 cm ² ; Mesh size 8 to 10 microns
Air cleaner	Mann & Hummel paper element type

GENERAL DATA

Rear axle and final drive

Rear Axle	
Type	Hypoid gear, centreline of drive pinion below centre of ring gear
Differential carrier material	Aluminium
Ring gear to Pinion gear backlash tolerance	0.13 to 0.20 mm (0.005 - 0.008 in)
Propellor shaft to rear driveshaft ratio	3.214 : 1
Final Drive	
Ratios:	
⇒ Td4 engine with manual gearbox	3.182 : 1
⇒ Td4 engine with automatic gearbox	2.91 : 1
⇒ K1.8 engine	4.200 : 1
⇒ KV6 engine	3.66 : 1
Hill Descent Control (HDC) speeds:	
Minimum forward	9.6 km/h (6.0 mph)
Minimum reverse	6.5 km/h (4.0 mph)
Viscous coupling	
Rating:	
⇒ Max	440 Nm (325 lbf.ft) @ 75 rpm
⇒ Min	360 Nm (265 lbf.ft) @ 75 rpm



Dimensions

Overall length (inc. 195/80 spare wheel/tyre):	
⇒ K1.8	4368 mm (14ft 4 in)
⇒ KV6	4433 mm (14 ft 7 in)
⇒ Td4	4368 mm (14ft 4 in)
Overall length (inc. 195/80 spare wheel/tyre):	
⇒ K1.8	4368 mm (14ft 4 in)
⇒ KV6	4433 mm (14 ft 7 in)
⇒ Td4	4368 mm (14ft 4 in)
Overall width (including mirrors)	2.068 m (6 ft 9.4 in)
Overall height (including roof bars and cross rails)*	1.708 m (5 ft 7.2 in)
Overall height (including roof bars and cross rails)*	
⇒ 3 door	1.808 m (5 ft 11.2 in)
⇒ 5 door	1.828 m (5 ft 11.9 in)
Ground clearance (minimum)*:	186 mm (7.3 in)
Wading depth (maximum)	400 mm (15.7 in)
Wheelbase	2.557 m (8ft 4.7 in)
Maximum approach angle °	30.5°
Maximum departure angle (with towbar)°	24°
Maximum departure angle (without towbar)°	33.9°
Maximum breakover angle	24°
Track:	
⇒ Front	1534 mm (60.4 in)
⇒ Rear	1545 mm (60.8 in)

* At EEC kerb weight

TORQUE WRENCH SETTINGS

Engine – KV6

TORQUE DESCRIPTION	METRIC	IMPERIAL
Bearing ladder to cylinder block bolts [†] ⇒ Stage 1 ⇒ Stage 2	20 Nm +90 °	15 lbf.ft +90 °
Camshaft carrier to cylinder head bolts †	10 Nm	7.5 lbf.ft
Camshaft cover to carrier bolts [†]	9 Nm	7 lbf.ft
Camshaft timing belt front cover backplate (LH) to cylinder head bolts	9 Nm	7 lbf.ft
Camshaft timing belt rear cover backplate to cylinder head bolts	9 Nm	7 lbf.ft
Camshaft timing belt tensioner bolts	25 Nm	18 lbf.ft
Camshaft timing gear bolts ⇒ Stage 1 ⇒ Stage 2	27 Nm +90 °	20 lbf.ft +90 °
Camshaft position sensor bracket to camshaft cover bolt	9 Nm	7 lbf.ft
Connecting rod big-end bolts ⇒ Stage 1 ⇒ Stage 2	20 Nm +70 °	15 lbf.ft +70 °
Crankcase (lower) to cylinder block bolts ⇒ M6 bolts ⇒ M8 bolts	35 Nm 35 Nm	7 lbf.ft 26 lbf.ft
Crankshaft pulley bolt	160 Nm	118 lbf.ft
Crankshaft rear oil seal to cylinder block bolts	9 Nm	7 lbf.ft
Cylinder head bolts [†] ⇒ Stage 1 ⇒ Stage 2	25 Nm +90 °	18 lbf.ft +90 °
Drain plug to sump	25 Nm	18 lbf.ft
Drive plate to crankshaft bolts †	80 Nm	59 lbf.ft
Earth lead to RH camshaft cover bolt	9 Nm	7 lbf.ft
Engine front mounting plate ⇒ M10 bolts ⇒ M12 bolts	45 Nm 85 Nm	33 lbf.ft 63 lbf.ft
Engine lifting bracket and front mounting plate to cylinder block and RH cylinder head bolts ⇒ M10 bolts ⇒ M12 bolts	25 Nm 45 Nm	18 lbf.ft 33 lbf.ft
Engine front mounting bracket to top arm bolts	100 Nm	74 lbf.ft
Engine mounting bracket to engine front plate bolts	45 Nm	33 lbf.ft
Engine mounting (LH) to body bolts	45 Nm	33 lbf.ft
Engine mounting bracket (LH) to gearbox bracket through bolt	85 Nm	63 lbf.ft
Engine mounting bracket (LH) to gearbox bracket through bolt	100 Nm	74 lbf.ft
Engine steady (lower) to sump bracket and subframe bolts	100 Nm	74 lbf.ft
Engine steady (upper RH) to body bolts	100 Nm	74 lbf.ft
Engine steady (upper RH) to top arm bolt	100 Nm	74 lbf.ft
Fuel rail to inlet manifold bolts	9 Nm	7 lbf.ft
Heat shield (RH rear timing belt) to cylinder head bolts ⇒ M6 ⇒ M8	9 Nm 25 Nm	7 lbf.ft 18 lbf.ft
Hydramount (RH)	85 Nm	63 lbf.ft
Idler pulley to engine front mounting plate Allen bolt	45 Nm	33 lbf.ft
Ignition coils to LH inlet manifold nut and bolts	9 Nm	7 lbf.ft



Manifolds and exhaust system – Td4

TORQUE DESCRIPTION	METRIC	IMPERIAL
Coolant rail to cylinder head bolt	20 Nm	15 lbf.ft
Coolant rail to exhaust manifold bolt	20 Nm	15 lbf.ft
Coolant rail to thermostat housing bolt	8 Nm	6 lbf.ft
EGR cooler to cylinder head and lifting bracket bolts	25 Nm	18 lbf.ft
EGR pipe clamp screw	10 Nm	7.5 lbf.ft
EGR pipe to cylinder head bolt	20 Nm	15 lbf.ft
EGR pipe to manifold Torx screws	22 Nm	16 lbf.ft
Exhaust manifold to cylinder head nuts	24 Nm	18 lbf.ft
Front pipe clamping plate nuts	50 Nm	37 lbf.ft
Front pipe to intermediate pipe flange nuts	60 Nm	44 lbf.ft
Fuel rail to coolant rail bolt	10 Nm	7.5 lbf.ft
Fuel rail to support bracket bolt	10 Nm	7.5 lbf.ft
Heat shield to coolant rail Allen screws	8 Nm	6 lbf.ft
Inlet manifold:		
⇒ M6 bolts	10 Nm	7.5 lbf.ft
⇒ M7 bolts and nuts	15 Nm	11 lbf.ft
Intermediate pipe to tail pipe flange nuts	60 Nm	44 lbf.ft
Tail pipe clamp nut	55 Nm	41 lbf.ft
Turbocharger to exhaust manifold bolts	50 Nm	37 lbf.ft
Turbocharger outlet pipe bolts:		
⇒6 mm	10 Nm	7.5 lbf.ft
⇒8 mm	25 Nm	18 lbf.ft

TORQUE WRENCH SETTINGS

Rear suspension and subframe

TORQUE DESCRIPTION	METRIC	IMPERIAL
Backplate to hub bolts	45 Nm	33 lbf.ft
Brake pipe to wheel cylinder union	14 Nm	10 lbf.ft
Damper shaft self locking nut	57 Nm	42 lbf.ft
Damper top mounting nuts	45 Nm	33 lbf.ft
Differential mountings to casing bolts	65 Nm	48 lbf.ft
Differential mountings to subframe	120 Nm	89 lbf.ft
Hub to damper nuts and bolts ²	205 Nm	151 lbf.ft
Hub drive shaft nut ¹	400 Nm	295 lbf.ft
Propeller shaft to rear axle bolts	65 Nm	48 lbf.ft
Road wheel nuts	115 Nm	85 lbf.ft
Subframe to body bolts	190 Nm	140 lbf.ft
Trailing link to rear hub nut and bolt ¹	120 Nm	89 lbf.ft
Transverse links to hub nut and bolt ¹	120 Nm	89 lbf.ft
Transverse link to subframe nuts and bolts ¹	120 Nm	89 lbf.ft

¹ Tighten with weight of vehicle on suspension



If the front of the vehicle is to be trailed, turn ignition key to position 'I' to release steering lock.

WARNING: Do not turn the starter switch to position '0' or remove the ignition key while the vehicle is being towed.

CAUTION: If it is considered unsafe to turn the starter switch to position '1' due to accident damage or an electrical fault; disconnect the battery before turning the ignition switch.

CAUTION: The steering wheel and/or linkage must be secured in a straight ahead position. DO NOT use the steering lock mechanism for this purpose.

CAUTION: Under no circumstances should the vehicle be towed or recovered by means of lashing to the rear subframe. Serious damage to the subframe and body could result.

CAUTION: Only use the rear towing eye for towing another vehicle.

Towing eyes

The towing eyes at the front and rear of the vehicle are designed for vehicle recovery purposes only and must not be used to tow a trailer or caravan.

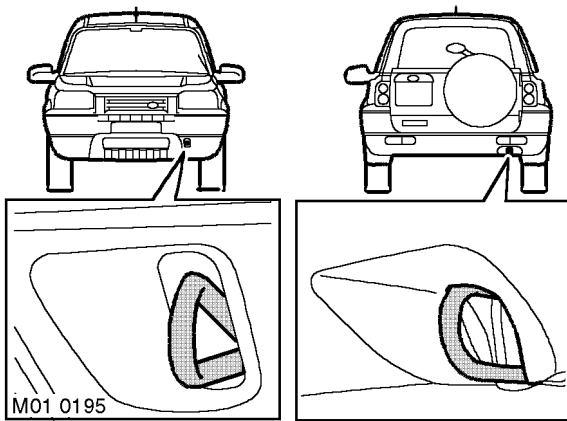

Front and rear towing eyes

A single towing eye is provided in the front spoiler. Only use when the vehicle is to be towed with all four wheels on the ground.

A single towing eye is provided in the rear RH spoiler. Only use when towing another vehicle.

Transporting the vehicle by trailer

Lashing rings are provided at the front and rear of the body to facilitate the securing of the vehicle to a trailer or other means of transportation.

CAUTION: Underbody components must not be used as lashing points. The lashing rings must not be used for towing.

Install the vehicle on trailer and apply the parking brake. Select neutral.

Lashing eyes

Lashing rings are provided at the front and rear of the vehicle for use when transporting by trailer. DO NOT use lashing eyes for towing purposes.

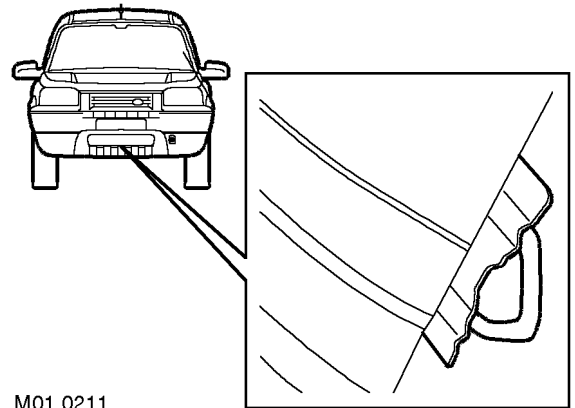

Front lashing eye

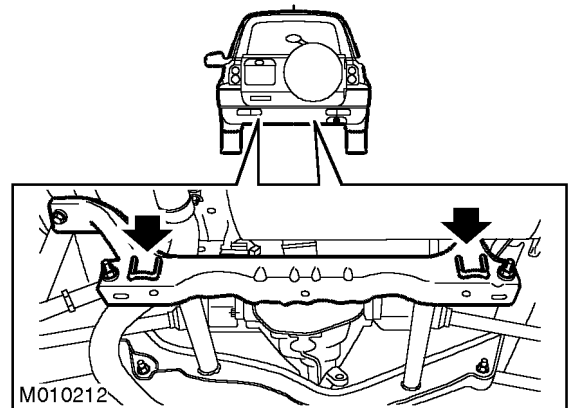

Rear lashing eyes

MAINTENANCE

Alarm handset battery

Replace

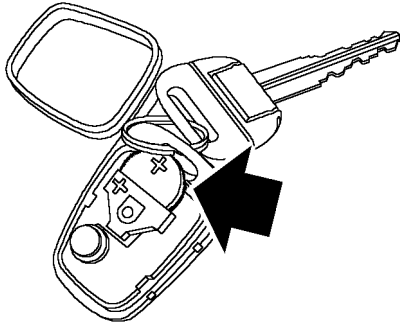

M10 0775

1. Insert the blade of a small, flat bladed screwdriver into the slot at the keyring end of the handset and carefully prise the two halves of the handset apart.
2. Slide the battery out of the clip taking care not to touch the circuit board or the battery contacts.
3. Press and hold each button in turn for at least 5 seconds to drain any residual power from the handset.
4. Fit the replacement battery (Land Rover STC4080 or Panasonic CR2032) ensuring the correct polarity is maintained (+) side facing upwards. Avoid touching the flat surfaces of the battery.
5. Press the 2 halves of the handset together, making sure the two halves click into place correctly.
6. Check the operation of the handset.

Road wheels

Remove

1. Loosen wheel nuts. Raise vehicle for wheel free condition and remove the wheel nuts.
2. Mark the wheel to stud relationship to ensure that the wheels are refitted in the same orientation.

Refit

1. Apply a thin coat of anti-seize compound to wheel hub centre.
2. Refit wheels to original hub position.
NOTE: When refitting road wheel nuts, do not overtighten using powered tools. Ensure the wheel nuts are correctly torqued in the correct sequence.

3. Tighten wheel nuts to 115 Nm.



Brake/clutch reservoir

Check/Top-up

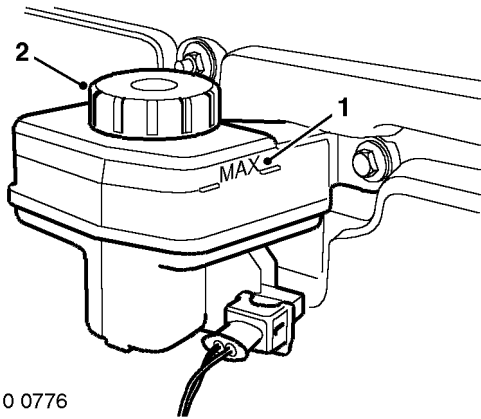

M10 0776

RHD shown, LHD similar

1. Check fluid level in brake/clutch fluid reservoir.
2. Clean area around filter cap, remove cap.
3. Top-up if necessary to correct level on reservoir using recommended fluid.

CAPACITIES, FLUIDS AND LUBRICANTS, Fluids.
4. Fit filler cap.

PAS fluid level

Check/Top-up

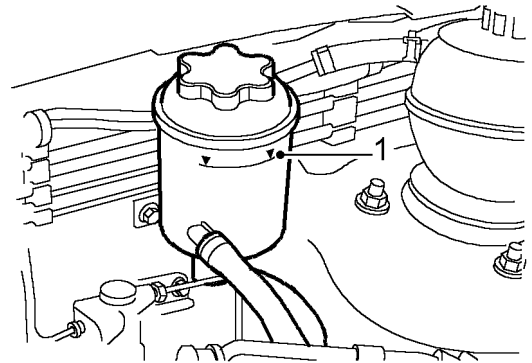

M10 0760

1. Check Power Assisted Steering (PAS) fluid level. Before topping up PAS fluid level, ensure there are no leaks from the pump, hoses, unions or steering rack.

CAPACITIES, FLUIDS AND LUBRICANTS, Fluids.

MAINTENANCE

Check rear suspension

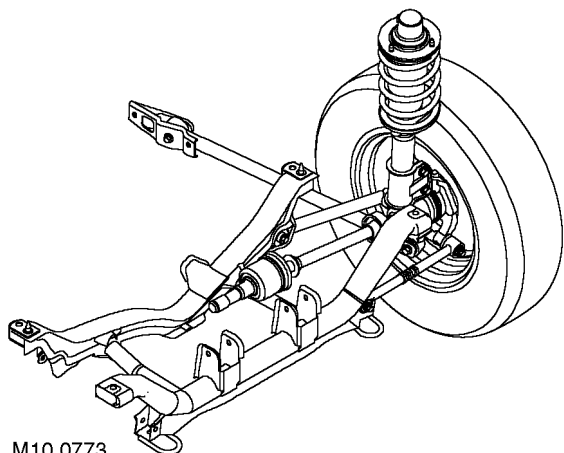

1. Check tightness of all accessible suspension fixings including transverse links.
2. Check wheel bearings and suspension struts for signs of excessive play or wear.
3. Check for signs of leakage from suspension dampers.

Steering

Check

1. Check for excessive play from steering joints.
2. Check condition of steering ball joints paying particular attention to dust covers.
3. Check steering rack bellows for any signs of leakage.



Camshaft - inlet or exhaust

🔑 12.13.02

Remove

1. Disconnect battery earth lead.
2. Remove ancillary drive belt.
 📌 **CHARGING AND STARTING, REPAIRS, Ancillary drive belt - Td4.**
3. Remove RH front road wheel.
WARNING: Do not work on or under a vehicle supported only by a jack. Always support the vehicle on safety stands.
4. Remove camshaft cover gasket.
 📌 **ENGINE - Td4, REPAIRS, Gasket - camshaft cover.**
5. Remove hydramount.
 📌 **ENGINE - Td4, REPAIRS, Hydramount - engine - RH.**

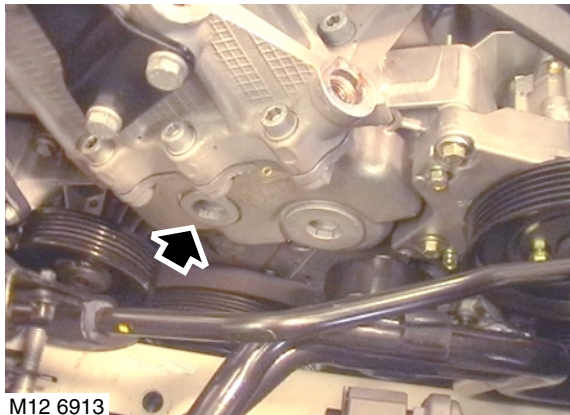

M12 6913

6. Remove chain tensioner access plug from timing cover.

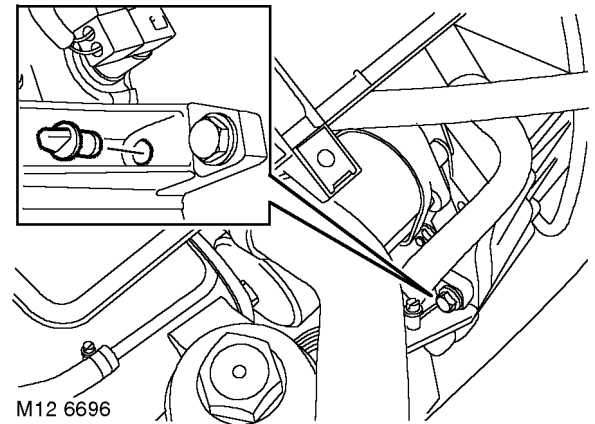

M12 6696

7. Remove blanking plug from crankshaft timing pin hole.

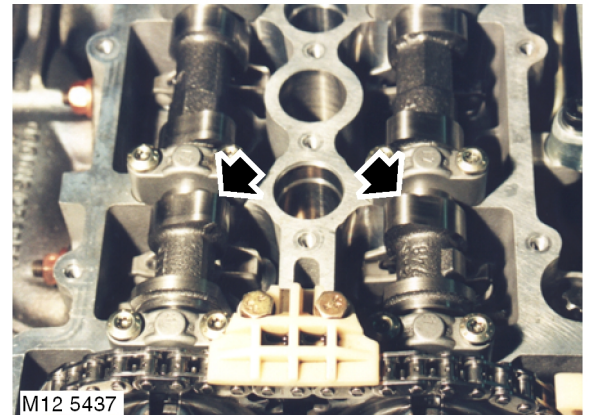

M12 5437

8. With a socket and bar fitted to pulley bolt, rotate crankshaft in direction of rotation until No 1 cylinder is at TDC position.

Refit

1. Clean crankshaft pulley and mating face.
2. Fit crankshaft pulley.
3. Fit washer and tighten new bolt securing crankshaft pulley initially to 100 Nm, followed by 60°, then a further 60° and finally by 30°
4. **Models with A/C:** Fit compressor drive belt.
☞ **AIR CONDITIONING, REPAIRS, Drive belt - compressor - Td4.**
5. Fit ancillary drive belt.
☞ **CHARGING AND STARTING, REPAIRS, Ancillary drive belt - Td4.**
6. Fit RH road wheel and tighten nuts to 115 Nm.
7. Remove stand(s) and lower vehicle.
8. Connect battery earth lead.

Crankshaft front oil seal

☞ 12.21.14

Remove

1. Disconnect battery earth lead.
2. Remove crankshaft pulley.
☞ **ENGINE - Td4, REPAIRS, Pulley - crankshaft.**

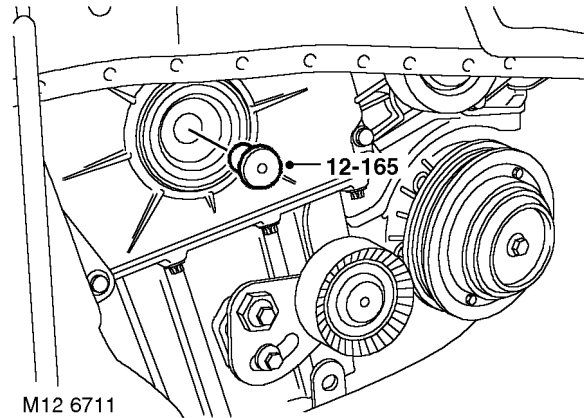

3. Fit thrust button 12-165 to end of crankshaft.
4. Ensure bore of 12-168 is free from burrs.

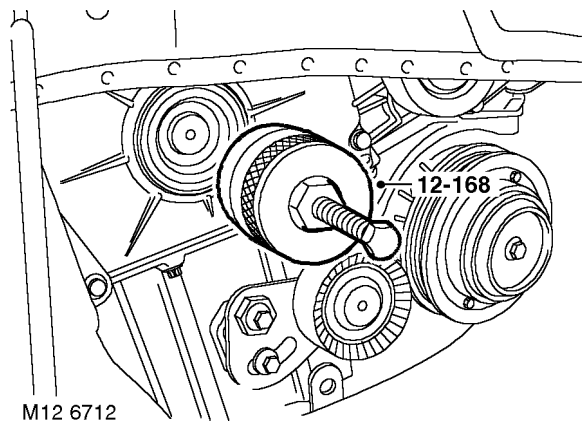

5. Fit 12-168 to crankshaft front oil seal and tighten bolt to remove seal.
6. Remove thrust button 12-165.

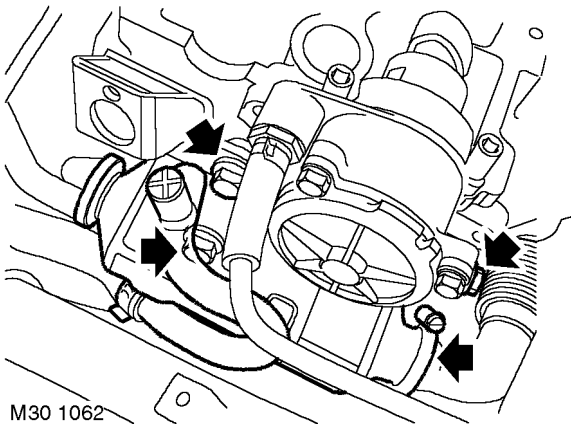

16. Loosen clamp screw securing EGR pipe to cooler and release clamp from cooler.
17. Remove 3 bolts securing EGR cooler to cylinder head and lifting bracket.

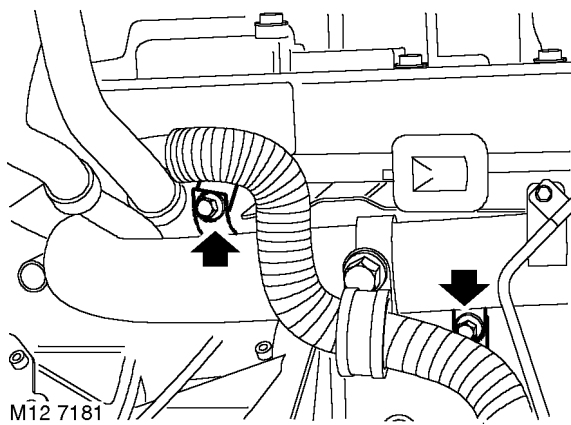

18. Remove bolt securing turbocharger outlet pipe to coolant rail.
19. Remove bolt securing turbocharger outlet pipe to bracket on exhaust manifold.

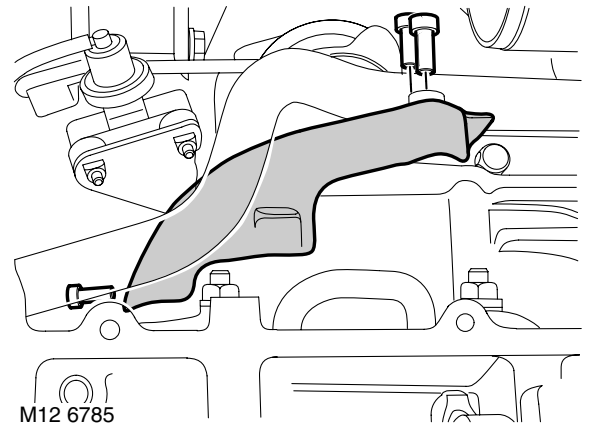

20. Remove 3 Allen screws heat shield to coolant rail.

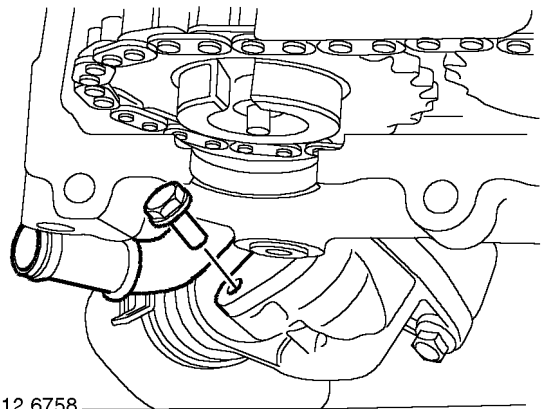

21. Remove bolt, release coolant rail from thermostat housing and discard seal.
22. Remove heat shield.

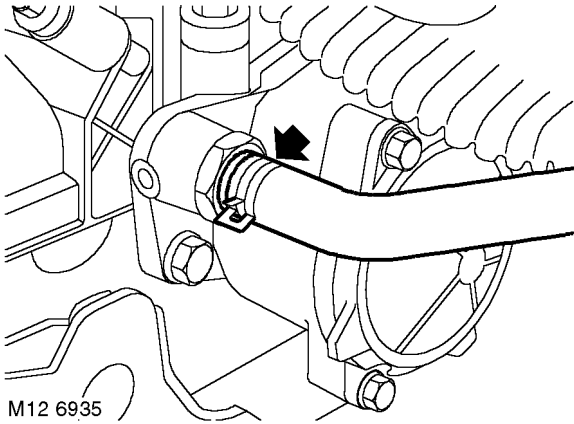

26. Release clip and disconnect hose from vacuum pump.

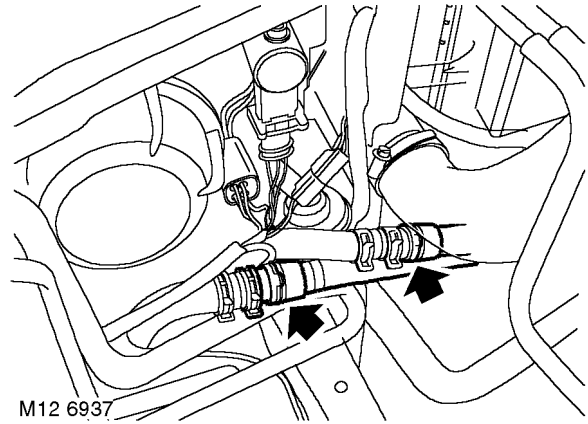

28. Release clips, disconnect coolant feed and return hoses from FBH.

29. Remove rear beam.

 **FRONT SUSPENSION, REPAIRS, Rear beam.**

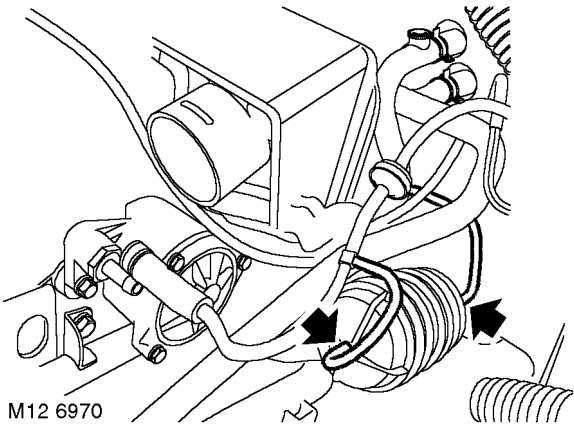

27. Note fitted position and carefully remove both vacuum hoses from reservoir.

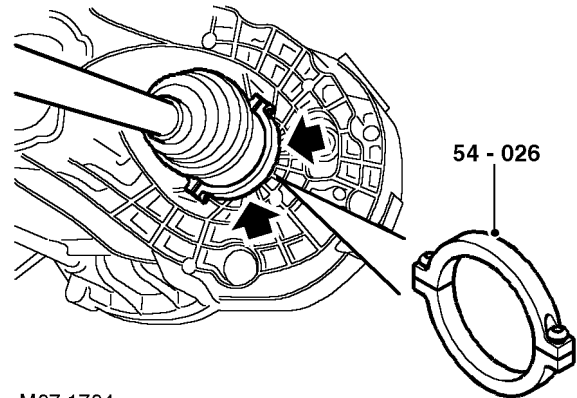

30. Secure **54-026**, to drive shaft inboard joints. Using a suitable lever, release drive shafts from IRD unit and gearbox.

31. With assistance, pull hubs outwards and remove drive shafts from gearbox and IRD unit.

32. Remove front exhaust pipe.

 **MANIFOLDS & EXHAUST SYSTEMS - Td4, REPAIRS, Exhaust pipe - front.**

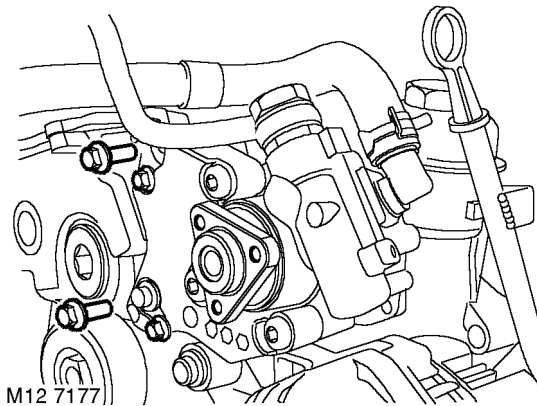

51. Remove 4 bolts securing PAS pump to mounting, release pump and tie aside.

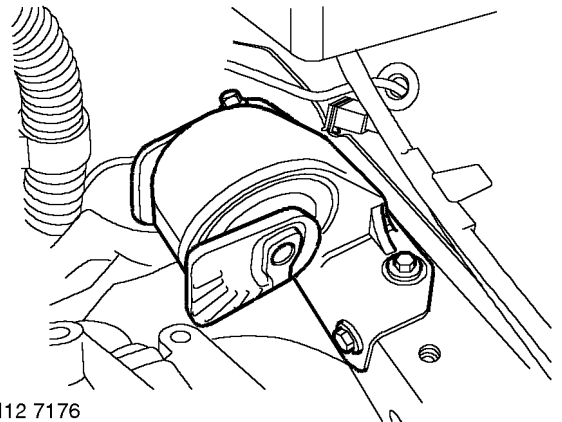

54. Remove snubber from mounting.

Refit

1. Using a hoist, connect adjustable lifting bracket, **LRT-12-138** to engine.
2. Fit snubber to mounting.
3. Raise engine and gearbox, align gearbox mounting bracket.
4. Adjust height of engine, fit through bolt securing gearbox mounting bracket to gearbox mounting on body and tighten bolt to 100 Nm.
5. Fit PAS pump. Tighten M6 bolts to 10 Nm. and M8 bolts to 24 Nm.
6. Fit PAS pump pulley and align bolts holes. Ensure FRONT mark is facing outwards. Fit bolts finger tight.
7. Use **12-163** to hold belt tensioner off and with assistance, fit ancillary belt. Ensure belt is correctly located in pulley grooves.
8. Tighten PAS pump pulley bolts to 10 Nm.
9. Fit hydramount.

ENGINE - Td4, REPAIRS, Hydramount - engine - RH.

10. Lower hoist, disconnect and remove lifting bracket, **LRT-12-138**.
11. Fit exhaust front pipe.

MANIFOLDS & EXHAUST SYSTEMS - Td4, REPAIRS, Exhaust pipe - front.
12. Fit propeller shaft to IRD flange and align marks. Tighten nuts and bolts to 40 Nm.
13. Fit rear beam.

FRONT SUSPENSION, REPAIRS, Rear beam.
14. Clean ends of drive shaft and locations in hub and differential.

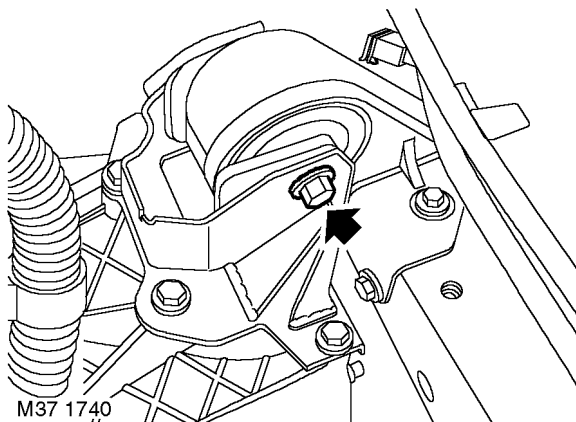

52. Remove through bolt securing LH engine mounting to gearbox bracket.
53. With assistance, manoeuvre and lower engine and gearbox to floor.

ENGINE - TD4

Gasket - sump

🔑 12.60.38

Remove

1. Disconnect battery earth lead.
2. Drain engine oil and remove filter.
👉 **MAINTENANCE, MAINTENANCE, Engine oil and filter – Td4.**
3. Remove RH front wheel.

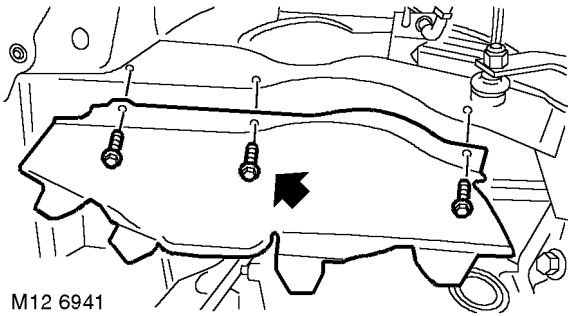

M12 6941

4. Remove 3 bolts and RH splash shield.

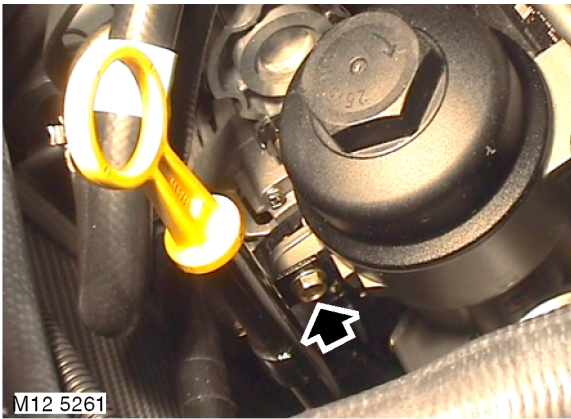

M12 5261

5. Remove bolt, dipstick tube to oil filter housing.

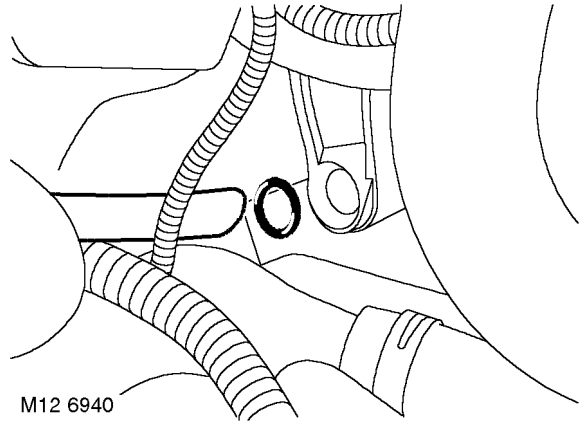

M12 6940

6. Remove dipstick tube and discard 'O' ring.

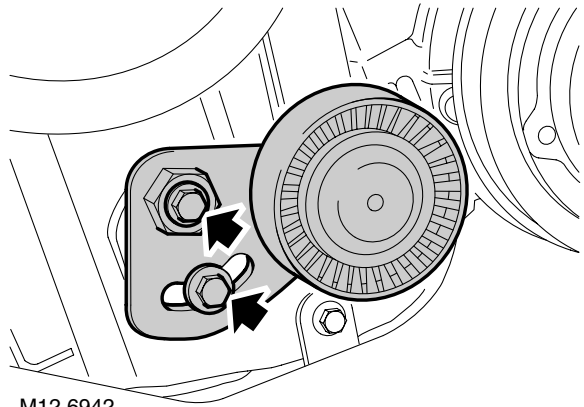

M12 6942

7. **Models with A/C:** Remove 2 bolts and compressor drive belt tensioner.

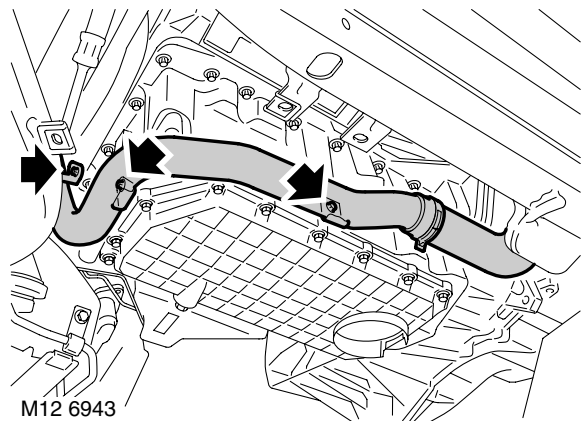

M12 6943

8. Remove 3 bolts securing coolant rail to sump and cylinder block.

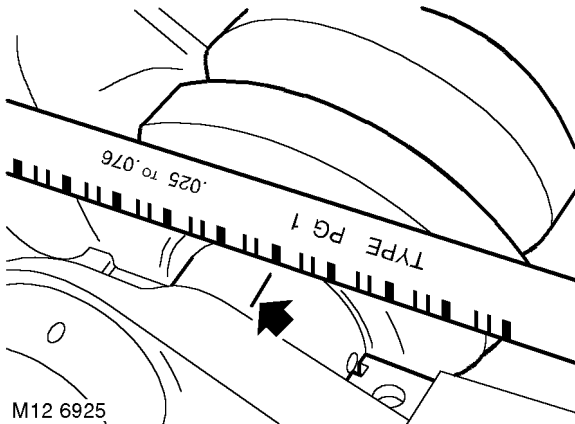

23. Using the scale provided, measure the width of Plastigauge on each main bearing journal and compare with specified bearing clearances.

GENERAL DATA, Engine – Td4 diesel.

24. If clearances are incorrect, select alternative main bearing cap shell(s) from the range available and repeat check.
25. Lift out crankshaft, remove all traces of Plastigauge from main bearing journals using clean engine oil and a cloth.
26. Fit selected bearing shells to main bearing caps.
27. Lubricate bearing journals and main bearing shells with clean engine oil.
28. Position crankshaft, fit main bearing caps and original bolts.
29. Tighten bolts to 20 Nm then a further 70°.
30. Position DTI gauge to front end of crankshaft, push crankshaft fully rearwards and zero gauge.
31. Push crankshaft fully in the opposite direction and note crankshaft end-float reading on gauge.

GENERAL DATA, Engine – Td4 diesel.

32. If crankshaft end-float is incorrect, remove crankshaft and select combined thrust/main bearing shells from the range available to give the correct end-float, ensuring that correct colour coding/size of bearing shell is maintained.

33. There are 3 widths of thrust/main bearing shells available.

GENERAL DATA, Engine – Td4 diesel.

34. Fit selected thrust/main bearing shells to cylinder block and main bearing cap.
35. Position crankshaft, main bearing caps and original bolts. Tighten main bearing cap bolts in a diagonal sequence to 20 Nm then a further 70°. Recheck crankshaft end-float.

GENERAL DATA, Engine – Td4 diesel.

36. **If crankshaft end-float is correct:**
Progressively loosen and remove main bearing cap bolts, discard bolts.

Refit

1. Lightly oil threads of new main bearing cap bolts and fit to cylinder block.
2. Tighten main bearing cap bolts in a diagonal sequence to 20 Nm then a further 70°.
3. Fit connecting rod bearings.
 ENGINE - Td4, REPAIRS, Connecting rod bearings - engine set.
4. Fit timing cover gasket.
 ENGINE - Td4, REPAIRS, Gasket - timing gear cover.
5. Fit crankshaft rear oil seal.
 ENGINE - Td4, REPAIRS, Crankshaft rear oil seal.

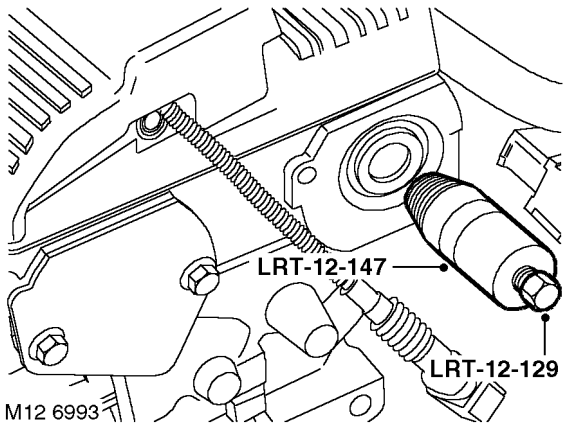

6. Remove camshaft oil seal using tool **LRT-12-147** and centre bolt from tool **LRT-12-129**.
7. Discard camshaft oil seal.

Refit

1. Clean oil seal recess and camshaft.
CAUTION: Oil seal must be fitted dry.

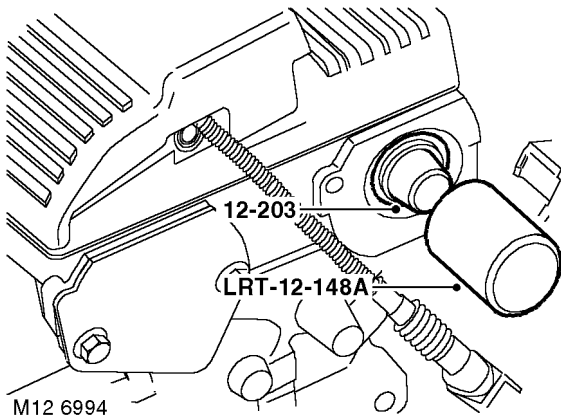

2. Ensure oil seal protector sleeve **12-203**, is clean. Fit sleeve to camshaft.
3. Fit seal using tool **LRT-12-148A**.
NOTE: Rear oil seals are red.
4. Clean cover plate and mating face.
5. Position cover plate, fit bolts and tighten to 25 Nm.
6. Connect CMP multiplug and secure in bracket.
7. Fit air cleaner assembly.
FUEL DELIVERY SYSTEM - PETROL, REPAIRS, Air cleaner - K1.8.
8. Connect battery earth lead.

Housing - camshafts - reseal & renew oil seals

12.13.22

Remove

1. Remove camshaft timing belt rear cover.
ENGINE - K SERIES 1.8, REPAIRS, Cover - timing belt - rear.
2. Remove camshaft cover.
ENGINE - K SERIES 1.8, REPAIRS, Gasket - camshaft cover.

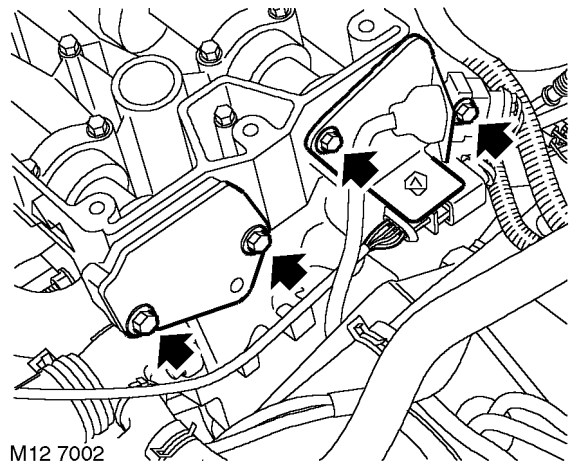

3. Remove 2 bolts securing oil seal cover plate to cylinder head and position aside.
4. Remove 2 bolts securing oil seal cover plate to cylinder head and remove plate.

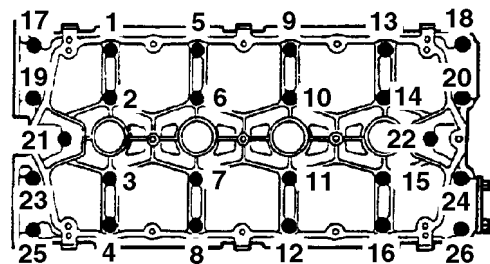

M12 7003

5. Working in the sequence shown, progressively loosen 26 bolts securing camshaft carrier to cylinder head until valve spring pressure is released.
6. Remove camshaft carrier.



Gasket - camshaft cover

🔑 12.29.40

Remove

1. Disconnect battery earth lead.

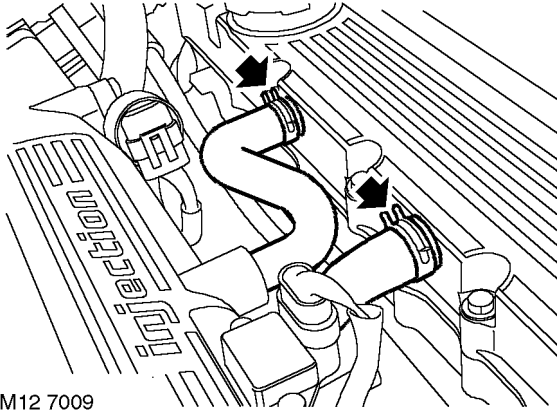

M12 7009

2. Release 2 clips and disconnect breather hoses from camshaft cover.
3. Remove ignition coils.

👉 **ENGINE MANAGEMENT SYSTEM - MEMS, REPAIRS, Ignition coil.**

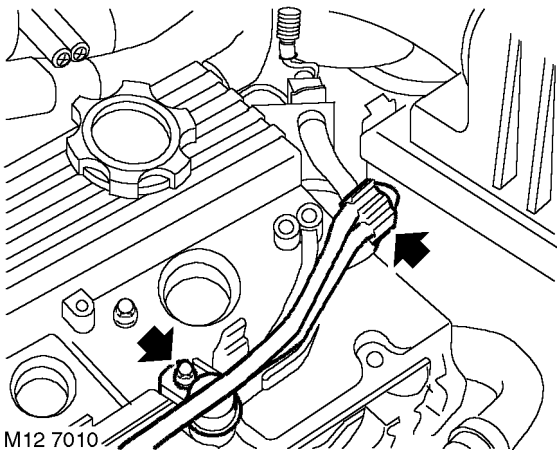

M12 7010

4. Release coil and CMP sensor harness clip from camshaft cover.
5. Remove bolt securing CMP sensor to cover, release sensor and position aside.

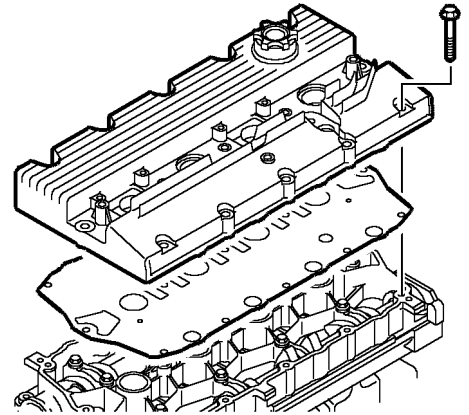

M12 7011

6. Progressively loosen and remove 15 bolts securing camshaft cover.
7. Remove camshaft cover and discard gasket.

Refit



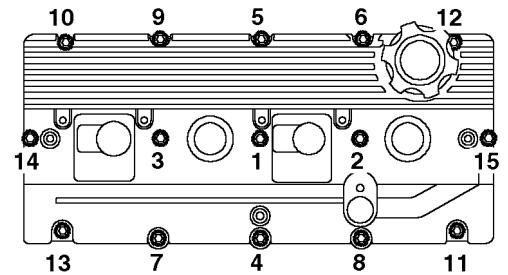





1. Clean mating surfaces of camshaft cover and carrier.
2. Clean inside of camshaft cover. If necessary, wash oil separator elements in solvent and blow dry.
3. Fit camshaft cover gasket.



M127012

4. Position camshaft cover, fit and tighten bolts progressively in the sequence shown to 9 Nm.
5. Clean CMP sensor and mating face. Fit sensor, fit bolt and tighten to 9 Nm.
6. Secure harness clip to cover.
7. Fit ignition coils.
- 👉 **ENGINE MANAGEMENT SYSTEM - MEMS, REPAIRS, Ignition coil.**
8. Connect breather hoses and secure with clips.
9. Connect battery earth lead.

ENGINE - K SERIES 1.8

54. Locate lower arm bushes, fit but do not fully tighten bolts.
CAUTION: Nuts and bolts must be tightened with weight of vehicle on suspension.
55. Clean bush housing and mating faces on beam.
56. Align bush housings ensuring roll pin is correctly located. Fit bolts and tighten to 105 Nm.
57. Position LH and RH splash shields, fit and tighten bolts.
58. Lower vehicle.
59. Tighten lower arm front bush bolts to 175 Nm.
60. Tighten lower arm rear bush nuts to 140 Nm.
61. Fit battery carrier.
 **CHARGING AND STARTING, REPAIRS, Carrier - battery.**
62. Adjust throttle cable.
 **FUEL DELIVERY SYSTEM - PETROL, ADJUSTMENTS, Throttle cable - check and adjust - K1.8.**
63. Fit air cleaner.
 **FUEL DELIVERY SYSTEM - PETROL, REPAIRS, Air cleaner - K1.8.**
64. If required, refill engine with oil.
 **MAINTENANCE, MAINTENANCE, Engine oil and filter – K1.8.**
65. Fill IRD to correct level with fluid.
 **INTERMEDIATE REDUCTION DRIVE, ADJUSTMENTS, Intermediate reduction drive (IRD) fluid - drain & refill.**
66. Refill gearbox with oil.
 **MANUAL GEARBOX - PG1, ADJUSTMENTS, Gearbox oil - drain and refill.**
67. Refill cooling system.
 **COOLING SYSTEM - K SERIES 1.8, ADJUSTMENTS, Coolant - drain & refill.**
68. Connect battery earth lead.
69. Fit bonnet.
 **EXTERIOR FITTINGS, REPAIRS, Bonnet.**

Arm assembly - engine mounting RH

 12.45.06

Remove

1. Remove underbelly panel.
 **EXTERIOR FITTINGS, REPAIRS, Panel - underbelly.**

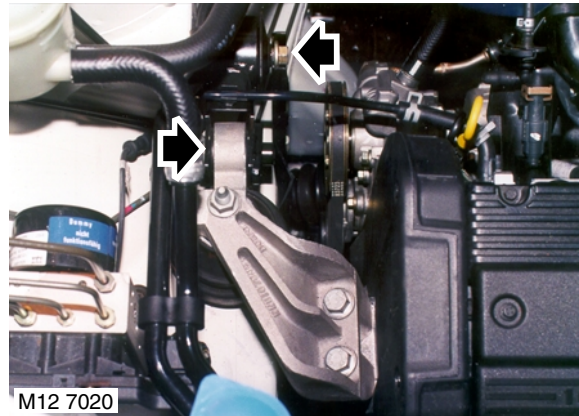

2. Remove bolt securing upper RH engine steady to top arm.
3. Loosen bolt securing upper RH engine steady to body, pivot engine steady away from top arm.
4. Fit wooden block to jack, position jack under engine sump to support engine.

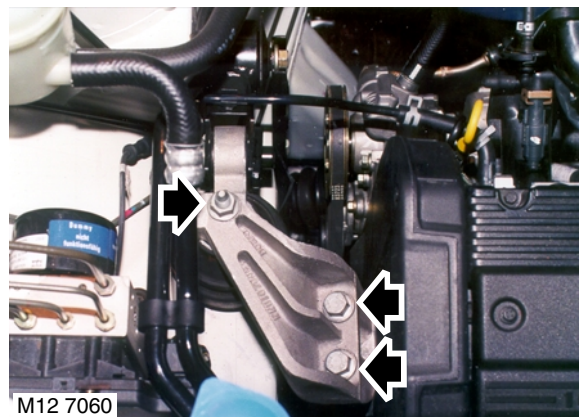

5. Remove nut securing engine top arm bracket to RH engine hydramount.
6. Remove 2 bolts securing top arm to engine front mounting bracket.
7. Remove top arm.



Cover - timing belt - rear

🔑 12.65.42

Remove

1. Remove camshaft timing belt.
 **ENGINE - K SERIES 1.8, REPAIRS, Camshaft timing belt.**

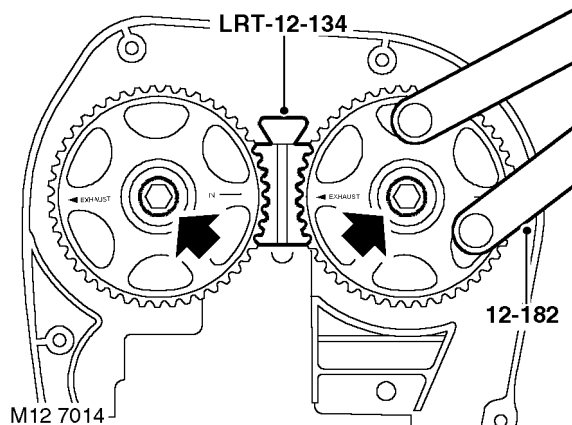

2. Remove camshaft gear alignment tool **LRT-12-134**.
3. Restrain gears using tool **12-182** and remove bolts and washers securing gears to camshafts.
4. Remove 2 camshaft gears.

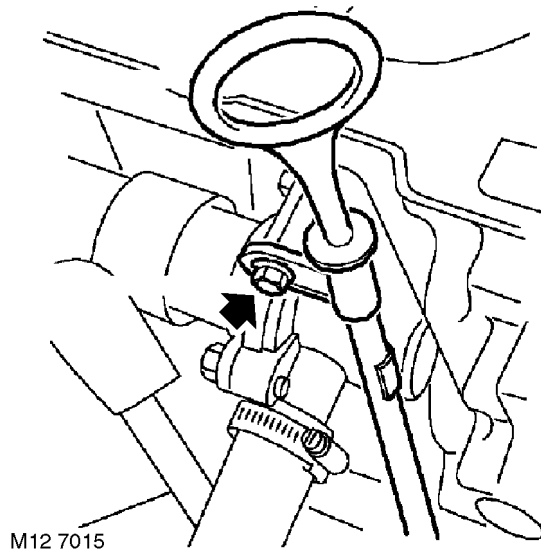

5. Remove bolt securing dipstick tube support bracket to thermostat housing.

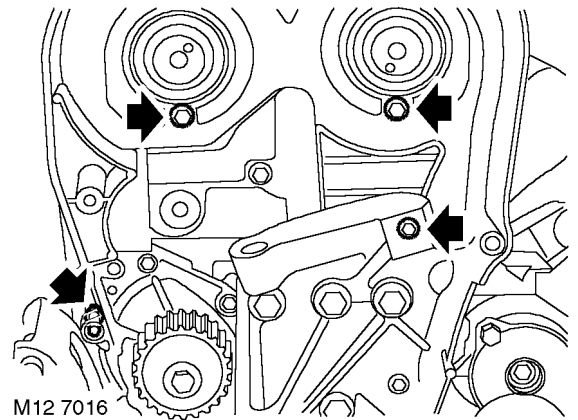

6. Remove 4 bolts securing camshaft timing belt rear cover to cylinder head and block.
7. Remove rear cover.

Refit

1. Fit timing belt rear cover and tighten bolts to 9 Nm.
2. Fit bolt securing dipstick tube support bracket and tighten to 9 Nm.
3. Clean camshaft timing gears.
4. Fit camshaft gears to their respective camshafts.
5. Fit bolts and washers securing camshaft gears to camshafts. Using tool **12-182** restrain camshaft gears and tighten bolts to 65 Nm.
6. Align camshaft gear timing marks and fit tool **LRT-12-134**.
7. Fit camshaft timing belt.
 **ENGINE - K SERIES 1.8, REPAIRS, Camshaft timing belt.**

ENGINE - K SERIES 1.8

11. Colour code on edge of bearing shell denotes bearing thickness as follows: GREEN = thin, BLUE = intermediate, RED = thick.

CAUTION: If two bearing colours are to be used, the thicker bearing must be fitted to bearing ladder. When original crankshaft is to be refitted, bearing shells must be as selected from table. Do not fit undersize bearings.

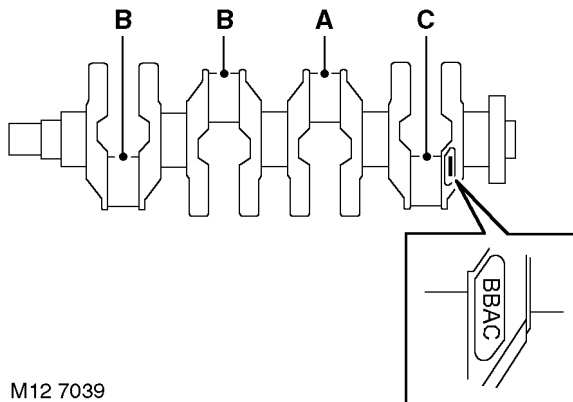

M12 7039

12. Record big-end journal code letters from crankshaft rear web. Reading from left to right, the first letter is Number 1 big-end bearing.

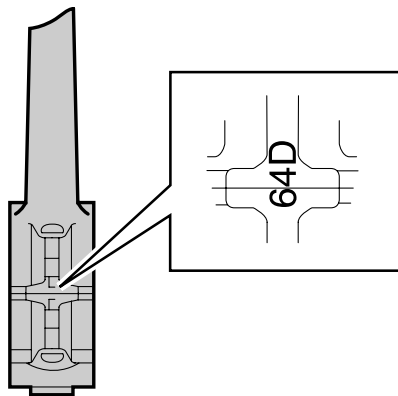

M12 7040

13. Record big-end bearing bore numbers. This will be 5, 6 or 7 located on the connecting rod bearing cap. Select required bearings.

GENERAL DATA, Engine – K1.8 petrol.

14. Colour code on edge of bearing denotes bearing thickness as follows: YELLOW = Thin, BLUE = Intermediate, RED = Thick. If two bearing colours are to be used, the thicker bearing must be fitted to the big-end bearing cap.
15. Fit selected main bearing shells, grooved into cylinder block and plain into bearing ladder.

16. Clean and fit new thrust washers into block, each side of No 3 main bearing with oil grooves facing outwards.
17. Lubricate crankshaft main bearing journals with clean engine oil.
18. Hold crankshaft with big end journals horizontal, lower crankshaft onto main bearings.
19. Ensure that mating faces of bearing ladder and cylinder block are clean and dry.

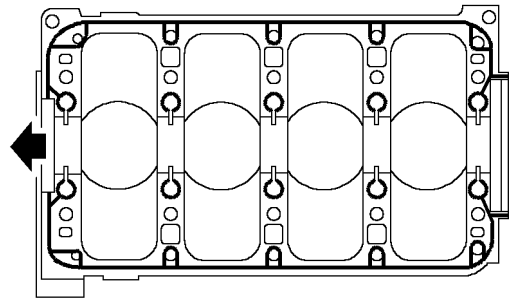

M12 7131

20. Apply a continuous bead of sealant from kit, Part Number GUG-705963GM, to paths shown on cylinder block then spread to an even film using a roller.

CAUTION: To avoid contamination, assembly should be completed immediately after application of sealant.

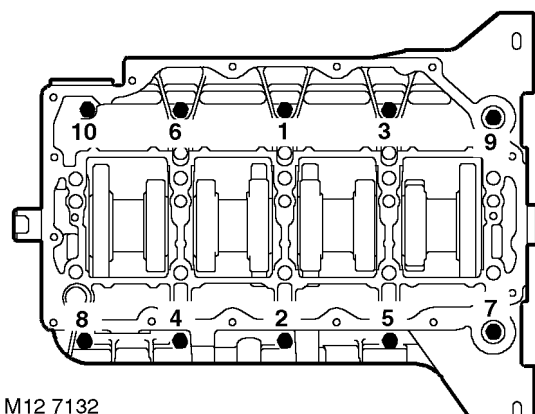

M12 7132

21. Lubricate main bearing journals with engine oil. Fit bearing ladder to block, fit bolts ensuring that flanged head bolt is fitted at position 10.
22. Tighten bolts in the sequence shown to 5 Nm then in the same sequence to 30 Nm.

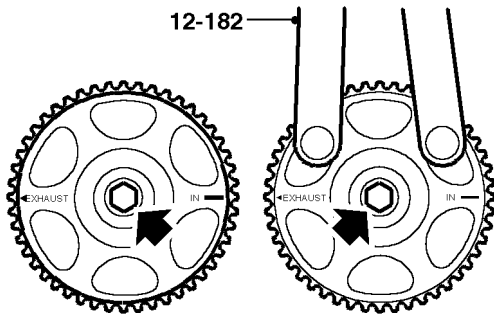

M12 7101

9. Using tool 12-182, remove bolts securing camshaft timing gears to camshafts. Remove timing gears, keeping them in their fitted order.

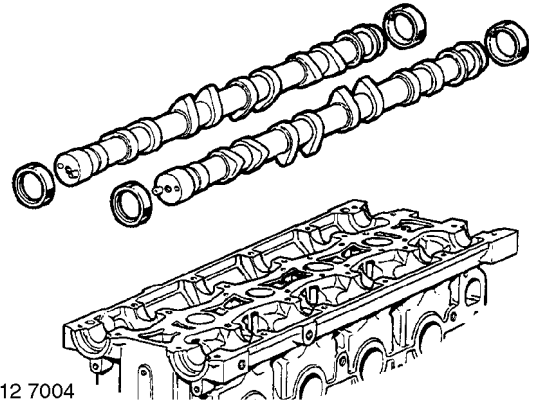

M12 7004

13. Note camshaft timing gear dowel positions and remove inlet and exhaust camshafts. Remove and discard 4 oil seals from camshafts.

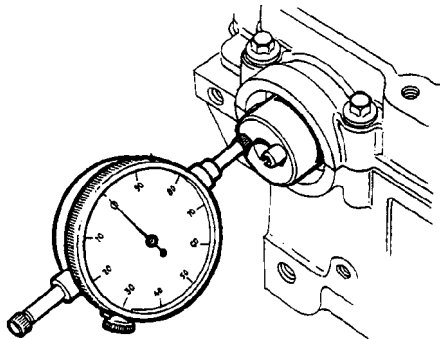

M12 7102

10. Check camshaft end-float using a DTI.
GENERAL DATA, Engine – K1.8 petrol.

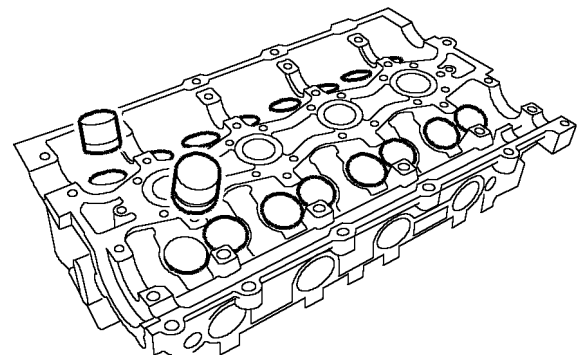

M12 7103

14. Using a stick magnet, remove 16 hydraulic tappets from cylinder head. Retain tappets in their fitted order and invert to prevent oil loss.
15. Check hydraulic tappets for signs of wear, scoring and overheating.
16. Measure outside diameter of each hydraulic tappet, measurement must be taken half-way along tappet body.
GENERAL DATA, Engine – K1.8 petrol.
17. Clean camshafts, bearing running surfaces in carrier and cylinder head, carrier and cylinder head mating faces.
18. Inspect camshafts and replace camshafts if scored, pitted or excessively worn.
19. Position camshafts in cylinder head and place Plastigauge across each journal.

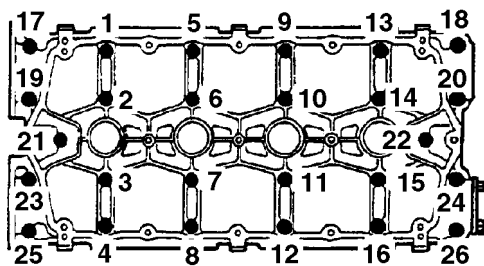

M12 7003

11. Working in the sequence shown, progressively loosen 26 bolts securing camshaft carrier to cylinder head, until valve spring pressure is released.
12. Remove camshaft carrier and support on wooden blocks.

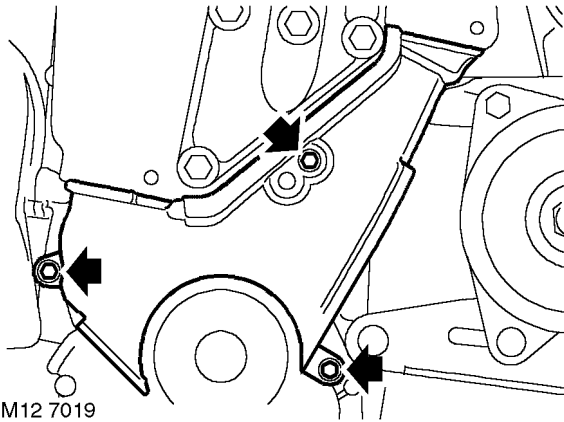

16. Remove 3 bolts securing camshaft timing belt lower cover to cylinder block and remove cover.

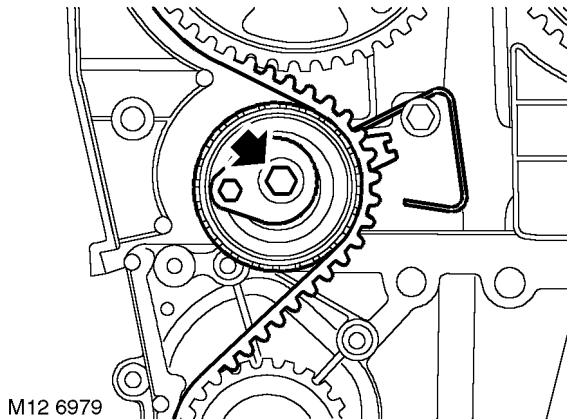

17. Remove and discard timing belt tensioner bolt.
 18. Disengage index wire from its fitted position whilst at the same time removing timing belt tensioner.
 19. If camshaft timing belt is to be refitted, mark direction of rotation on timing belt.

Refit

1. Clean crankshaft timing gear, camshaft timing gears, coolant pump drive gear and tensioner pulley.

CAUTION: If sintered gears have been subjected to prolonged oil contamination, they must be soaked in solvent and then thoroughly washed in clean solvent before refitting. Because of the porous construction of sintered material, oil impregnated in the gear will emerge and contaminate the belt.

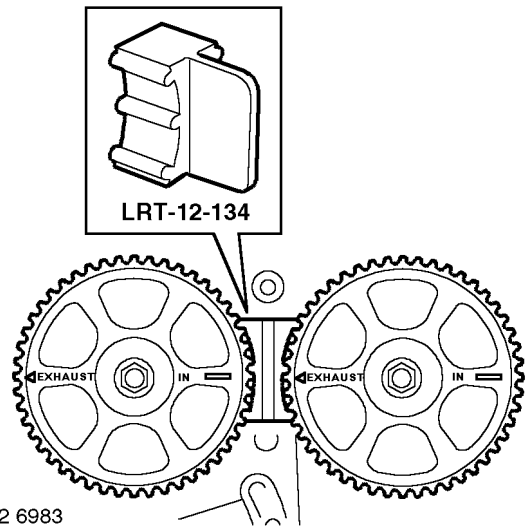

2. Check correct alignment of camshaft timing marks and that tool **LRT-12-134** is locking camshaft gears.

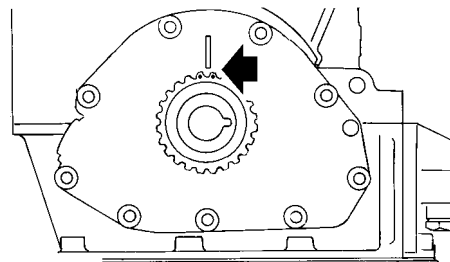

3. Check correct alignment of dots on crankshaft gear with flange on oil pump.

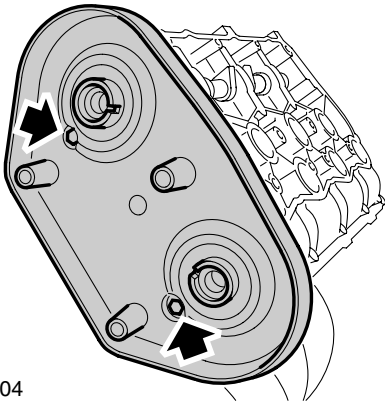

M12 6904

10. Remove 2 bolts securing RH rear timing belt cover backplate and remove backplate.

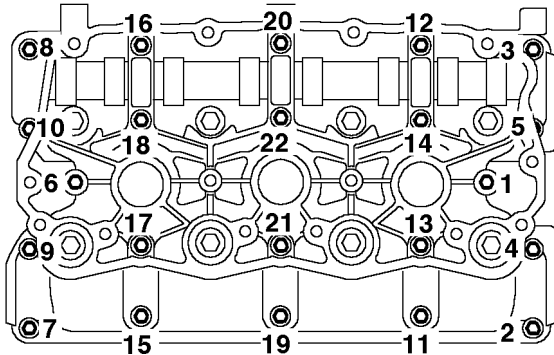

M12 6885

11. Using sequence shown, progressively loosen 22 bolts securing camshaft carrier to cylinder head until valve spring pressure is released and remove bolts.
12. Release camshaft carrier from dowels and remove carrier.

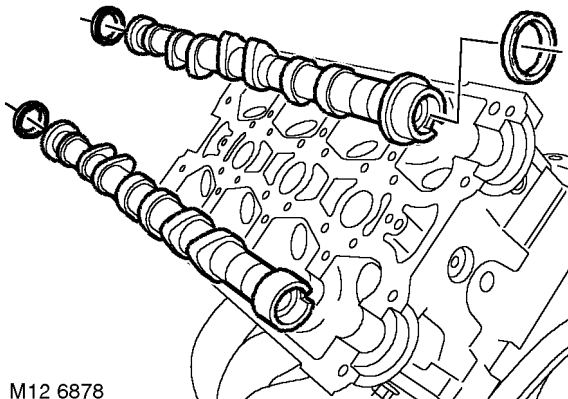

M12 6878

13. Remove both camshafts and discard oil seals.

14. Using a stick magnet, remove 12 hydraulic tappets from cylinder head.

CAUTION: Store hydraulic tappets in their fitted order and store upright. Maintain absolute cleanliness when handling hydraulic tappets. Failure to observe these precautions can result in engine failure.

15. Clean camshafts and bearing running surfaces in camshaft carrier and cylinder head.
16. Inspect camshafts and replace camshafts if scored, pitted or excessively worn.
17. Use a lint-free cloth and solvent, clean sealing surfaces on cylinder head and camshaft carrier.
18. Position camshafts in cylinder head and place Plastigauge across each journal.

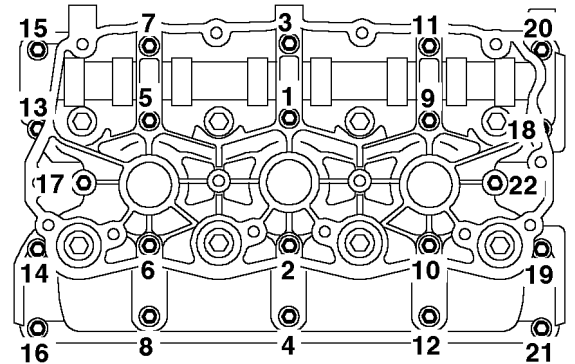

M12 6896

19. Refit camshaft carrier and tighten bolts in sequence to 10 Nm. DO NOT rotate camshaft.

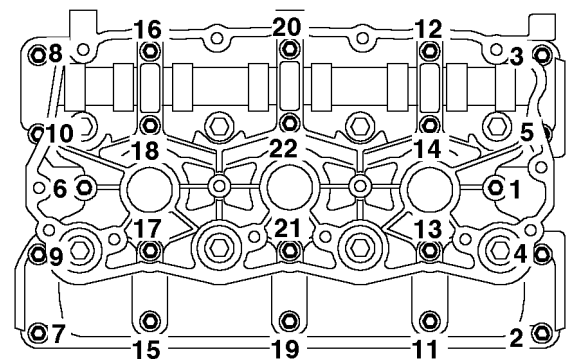

M12 6885

20. Using the sequence shown, progressively loosen and remove camshaft carrier bolts. Release and remove camshaft carrier from cylinder head.

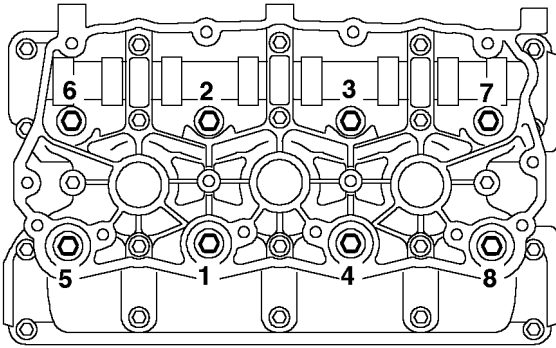

M12 6734

10. Tighten cylinder head bolts progressively in the sequence illustrated to 25 Nm. Retorque in the same sequence to 25 Nm. Using an angle torque gauge, tighten bolts in the same sequence to 90°, then tighten bolts a further 90°.

NOTE: The construction of the cylinder head gasket is such that it compresses on the initial tightening sequence. Therefore it is necessary to repeat the sequence to 25 Nm to ensure that the correct starting torque is reached before the first 90° turn is initiated.

11. Clean mating surfaces of camshaft cover and carrier.
12. Clean inside of camshaft cover. If necessary, wash oil separator gauze and blow dry.
13. Fit gasket and position camshaft cover to carrier.

CAUTION: When fitting camshaft cover gasket, ensure arrows on gasket point towards inlet manifold.

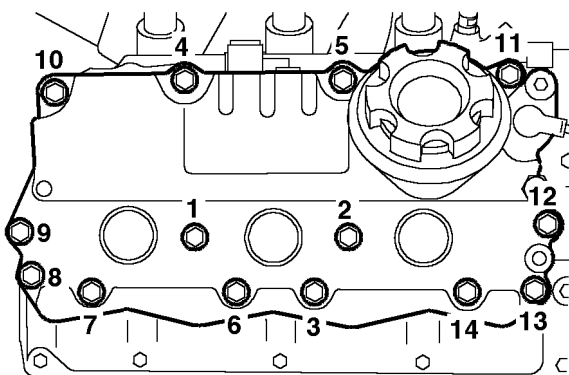

M12 6659

14. Fit bolts and tighten in sequence illustrated to 9 Nm.

15. Remove and discard 'O' rings from injectors.
16. Clean injectors and injector locations in fuel rail.
17. Lubricate new 'O' rings with castor oil and fit to injectors.
18. Position fuel rail assembly and secure injectors to inlet manifolds.
19. Position injector protection cover to RH fuel rail and secure injector harness to protection cover with clips.
20. Fit bolts securing fuel rail to inlet manifolds and tighten to 9 Nm.
21. Position CMP sensor bracket, fit and tighten bolt to 9 Nm.
22. Connect CMP sensor multiplug and secure to bracket.
23. Connect breather hose to LH inlet manifold.
24. Connect coolant bleed hose to inlet manifold and secure with clip.
25. Position ignition coils to LH inlet manifold.
26. Position earth lead, fit nuts and bolts securing ignition coils to LH inlet manifold and tighten to 9 Nm.
27. Position ht lead guide bracket, fit and tighten special bolt.
28. Connect ht leads to spark plugs and secure ht leads in guide clips.
29. Clean camshaft timing belt cover backplate bolts and apply Loctite 242 to the first 3 threads.
30. Position backplate, fit and tighten bolts to 9 Nm.
31. Fit camshaft timing belt.
 - 👉 **ENGINE - K SERIES KV6, REPAIRS, Camshaft timing belt.**
32. Fit LH exhaust manifold gasket.
 - 👉 **MANIFOLDS & EXHAUST SYSTEMS - K SERIES KV6, REPAIRS, Gasket - exhaust manifold - LH.**
33. Fit inlet manifold chamber.
 - 👉 **MANIFOLDS & EXHAUST SYSTEMS - K SERIES KV6, REPAIRS, Seals - inlet manifold chamber.**
34. Fill cooling system.
 - 👉 **COOLING SYSTEM - K SERIES KV6, ADJUSTMENTS, Coolant - drain and refill.**

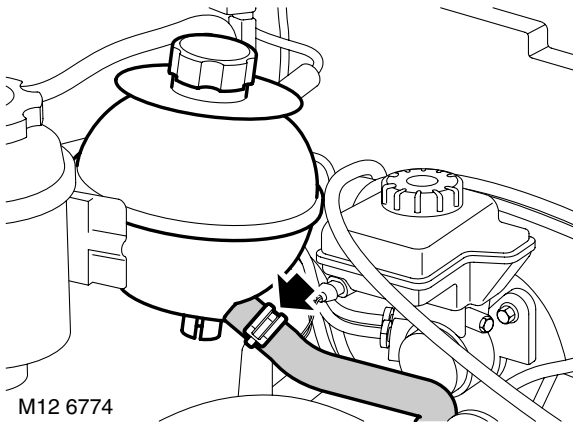

28. Release clip and disconnect hose from underside of expansion tank.

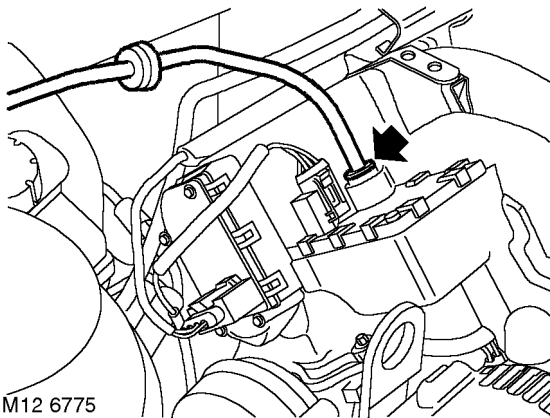

29. Depress locking collar and disconnect brake servo hose from inlet manifold chamber.
 30. Raise vehicle on ramp.
 31. Remove front road wheels.
 32. Release stake in drive shaft nuts.

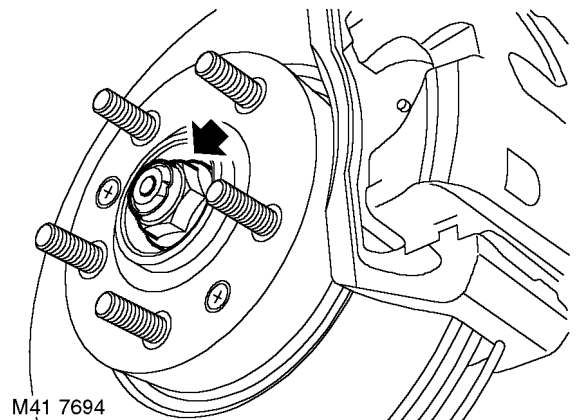

33. With an assistant depressing the brake pedal, remove and discard LH and RH drive shaft nuts.
 34. Remove rear beam.
FRONT SUSPENSION, REPAIRS, Rear beam.
 35. Remove exhaust front pipe.
MANIFOLDS & EXHAUST SYSTEMS - K SERIES KV6, REPAIRS, Front pipe.
 36. Raise one rear wheel for rotation of propeller shaft to access bolts.

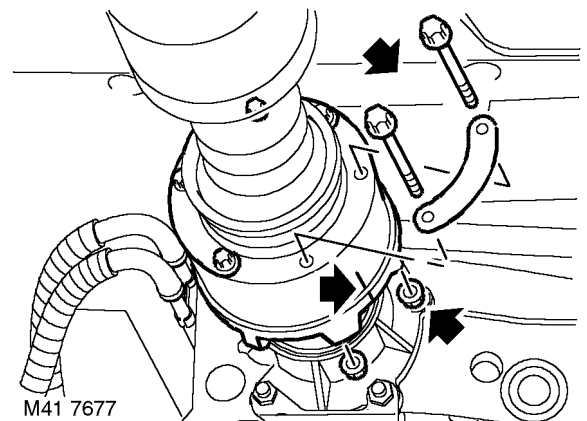

37. Reference mark position of viscous coupling flange to IRD unit flange to aid reassembly.
 38. Remove 6 nuts and bolts securing propeller shaft to IRD drive flange.
 39. Release propeller shaft from IRD drive flange and tie shaft aside.

CAUTION: Care must be taken to support the Tripode joint when removed from the IRD unit. To avoid damage to gaiter or steel can, the joint should not be allowed to fully extend or be dropped.

ENGINE - K SERIES KV6

Filter - engine oil

🔑 12.60.04

Remove

1. Raise vehicle on a 4 post ramp.
2. Remove underbelly panel.
👉 **EXTERIOR FITTINGS, REPAIRS, Panel - underbelly.**
3. Place suitable container under oil filter to collect spillage.

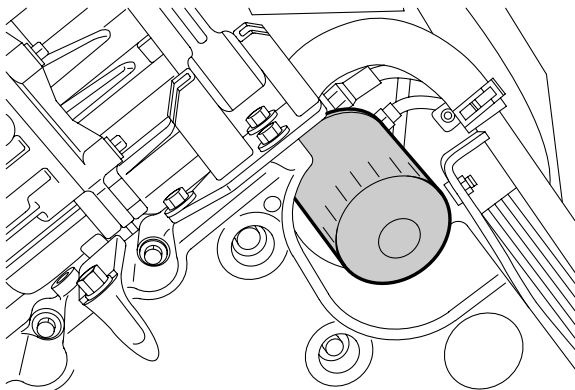

M12 6660

4. Using strap wrench, remove and discard oil filter.

WARNING: Avoid excessive skin contact with used engine oil. Used engine oil contains potentially harmful contaminants which may cause skin cancer or other serious skin disorders.

Refit

1. Clean oil filter mating face.
2. Lubricate new oil filter sealing ring with clean engine oil.
3. Fit new oil filter and tighten by hand until it seats, then tighten a further half turn.
4. Remove oil container from underneath of engine.
5. Fit underbelly panel.
👉 **EXTERIOR FITTINGS, REPAIRS, Panel - underbelly.**
6. Lower vehicle on ramp.
7. Start and run engine and check for leaks.
8. Stop engine, wait a few minutes, then check oil level. Top up if necessary.

Oil pick-up strainer

🔑 12.60.20

Remove

1. Disconnect battery earth lead.
2. Remove engine sump.
👉 **ENGINE - K SERIES KV6, REPAIRS, Sump - reseal.**

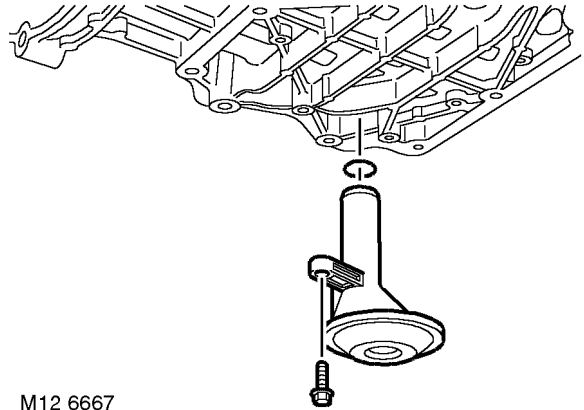

M12 6667

3. Remove bolt and remove oil pick-up strainer. Remove and discard 'O' ring.

Refit

1. Clean oil pick-up strainer and mating face.
2. Lubricate new 'O' ring with clean engine oil and fit to pick-up strainer.
3. Position oil pick-up strainer, fit and tighten bolt to 25 Nm.
4. Fit engine sump.
👉 **ENGINE - K SERIES KV6, REPAIRS, Sump - reseal.**
5. Connect battery earth lead.

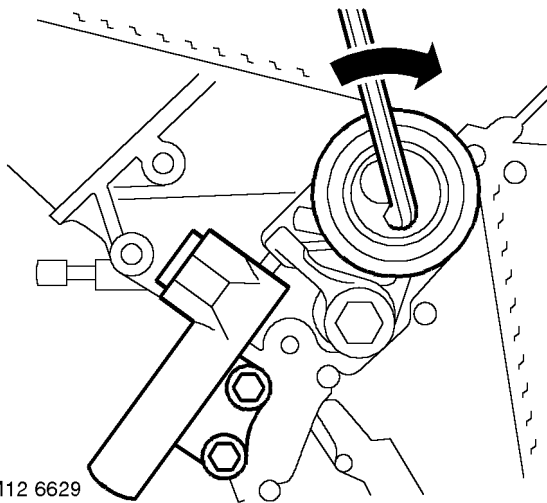

M12 6629

34. With assistance, relieve tension from camshaft timing belt tensioner using an Allen key fitted in the tensioner pulley backplate. Remove 2 bolts securing tensioner to cylinder block and remove tensioner.

CAUTION: DO NOT loosen Allen screw securing tensioner pulley.

35. If camshaft timing belt is to be refitted, mark direction of rotation on timing belt before removal.
36. With care, ease camshaft timing belt from gears using fingers only and remove timing belt.

CAUTION: Camshaft timing belt must be replaced if cylinder head is to be removed or new drive gears, tensioner or coolant pump are to be fitted. Camshaft timing belts must be stored and handled with care. Always store a camshaft timing belt on its edge with a bend radius greater than 50 mm. Do not use a camshaft timing belt that has been twisted or bent double as this will damage the reinforcing fibres. Do not use a camshaft timing belt if debris other than belt dust is found in timing belt covers. Do not use a camshaft timing belt if partial engine seizure has occurred. Do not use a camshaft timing belt if mileage exceeds 48,000 miles (77,000 km). Do not use an oil or coolant contaminated timing belt, cause of contamination must be rectified.

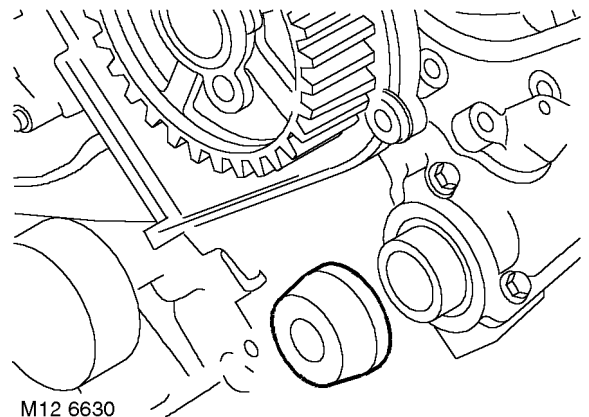

M12 6630

37. Remove LH and RH exhaust camshaft cap seals.

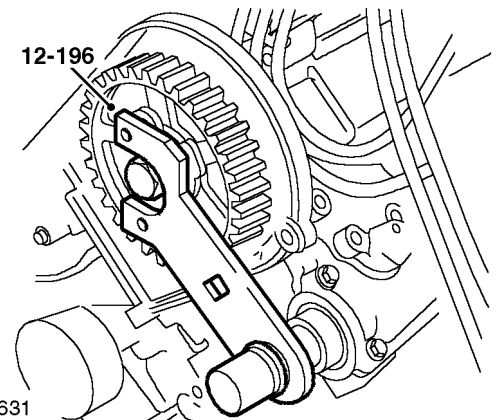

M12 6631

38. Position tools **12-196** to LH and RH front inlet camshaft gears and into the end of each exhaust camshaft.
- CAUTION: Special tools must be fitted when tightening or loosening gear retaining bolts, otherwise damage to camshafts may occur.**
39. Remove and discard bolts retaining front inlet camshaft gears to camshafts.
40. Remove tools **12-196** from both inlet camshaft gears and exhaust camshafts.
41. Remove camshaft drive gears and hub assemblies.



Crankshaft front oil seal

🔑 12.21.14.01

Remove

1. Remove camshaft timing belt.
 **ENGINE - K SERIES KV6, OVERHAUL, Camshaft timing belt.**

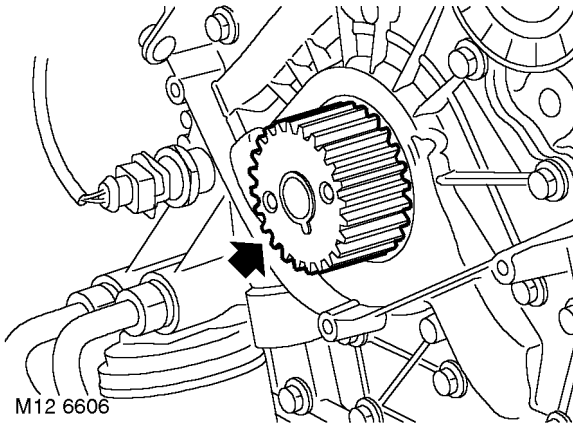

2. Remove crankshaft drive gear.

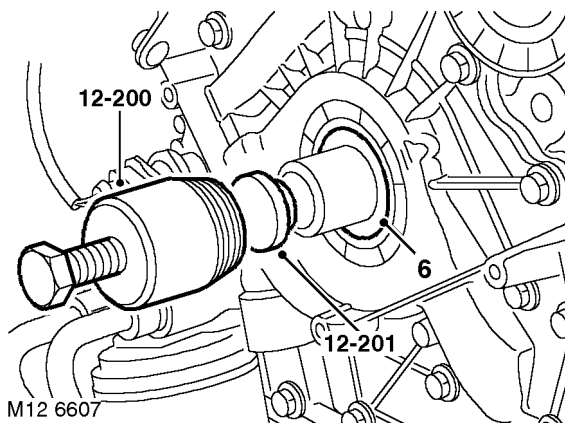

3. Fit thrust button, **12-201** to end of crankshaft.
4. Screw **12-200** into crankshaft front oil seal.
5. Tighten centre bolt of **12-200** to remove oil seal.
6. Remove and discard oil seal from special tool.
7. Remove thrust button from crankshaft.

Refit

1. Using a lint free cloth, thoroughly clean oil seal recess in oil pump and running surface on crankshaft.
2. Fit oil seal guide from seal kit, over end of crankshaft.

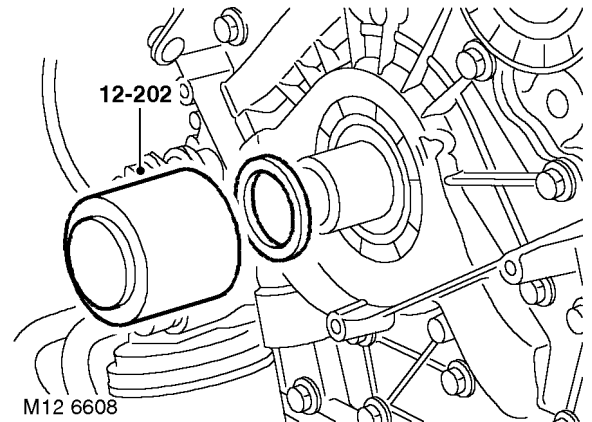

3. Position new seal on crankshaft up against oil pump housing. Drift seal into place using tool **12-202**.
4. Remove **12-202** and oil seal guide from crankshaft.
5. Clean crankshaft gear and wipe end of crankshaft.
6. Fit drive gear to crankshaft.
7. Fit camshaft timing belt.
 **ENGINE - K SERIES KV6, OVERHAUL, Camshaft timing belt.**

ENGINE - K SERIES KV6

15. Remove and discard 'O' rings from injectors.
16. Clean injectors and injector locations in fuel rail.
17. Lubricate new 'O' rings with castor oil and fit to injectors.
18. Position fuel rail assembly and secure injectors to inlet manifolds.
19. Position injector protection cover to RH fuel rail and secure injector harness to protection cover with clips.
20. Fit bolts securing fuel rail to inlet manifolds and tighten to 9 Nm.
21. Position CMP sensor bracket, fit and tighten bolt to 9 Nm.
22. Connect CMP sensor multiplug and secure to bracket.
23. Connect coolant bleed hose to inlet manifold and secure with clip.
24. Connect breather hose to LH inlet manifold.
25. Position ignition coils to LH inlet manifold.
26. Position earth lead, fit nuts and bolts securing ignition coils to LH inlet manifold and tighten to 9 Nm.
27. Position ht lead guide bracket, fit and tighten special bolt.
28. Connect ht leads to spark plugs and secure ht leads in guide clips.
29. Clean camshaft drive belt cover backplate bolts and apply Loctite 242 to first 3 threads.
30. Position backplate, fit and tighten bolts to 9 Nm.
31. Clean exhaust manifold and cylinder head mating face.
32. Fit new exhaust manifold gasket, position exhaust manifold, fit nuts and tighten to 45 Nm.
33. Secure HO2S lead in clip on cylinder block.
34. Connect HO2S multiplug and secure to support bracket.

Cylinder head gasket - RH

🔑 12.29.03.01

Remove

1. Remove inlet manifold chamber.
👉 **MANIFOLDS & EXHAUST SYSTEMS - K SERIES KV6, OVERHAUL, Gasket(s) - manifold chamber.**
2. Remove camshaft timing belt.
👉 **ENGINE - K SERIES KV6, OVERHAUL, Camshaft timing belt.**

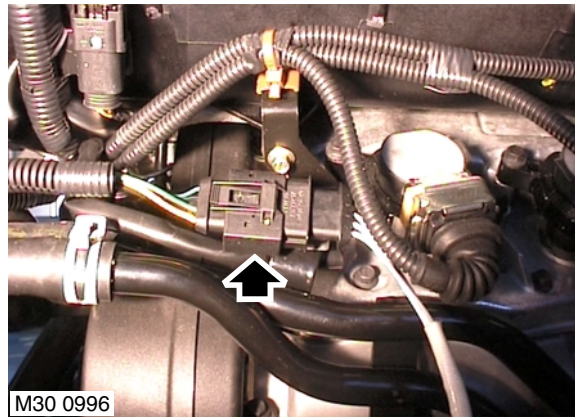

3. Release RH HO2S multiplug from coolant rail bracket and disconnect multiplug.

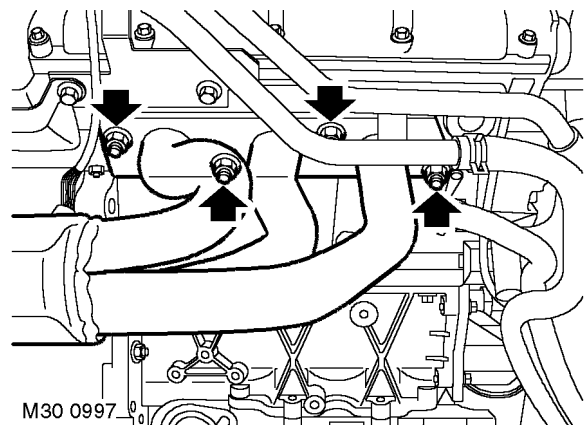

4. Remove 4 nuts securing RH exhaust manifold to cylinder head.
5. Remove exhaust manifold, remove and discard gasket.

**Refit**

1. Fit cylinder head.

 **ENGINE - K SERIES KV6, REPAIRS,**
Cylinder head gasket - RH.

Sump - engine oil

 **12.60.38.01**

Remove

1. Drain engine oil.

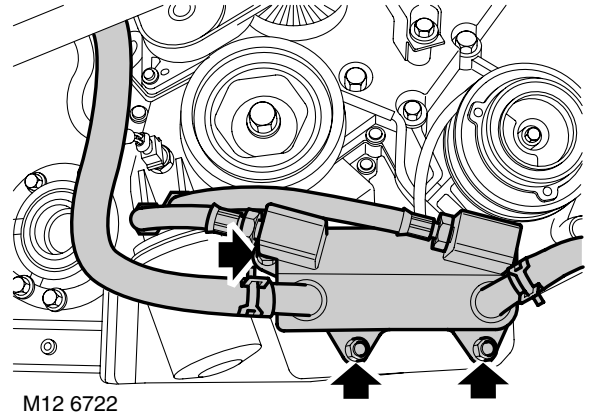

2. Remove 3 nuts securing engine oil cooler to sump and position oil cooler aside.

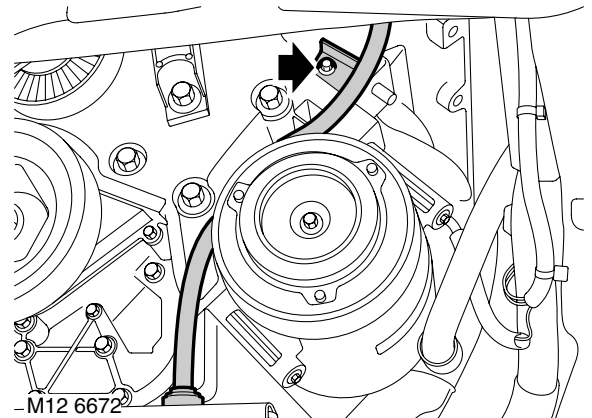

3. Remove bolt securing dipstick tube to cylinder block.
4. Depress collar and remove dipstick tube from sump.

EMISSION CONTROL

Valve - EGR - Td4

🔑 17.45.01

Remove

1. Disconnect battery earth lead.
2. Remove intake ducting assembly.
👉 **FUEL DELIVERY SYSTEM - DIESEL, REPAIRS, Ducting - intake assembly.**

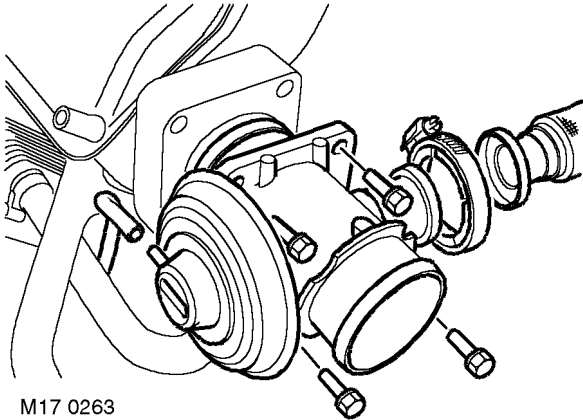

3. Disconnect vacuum hose from EGR valve.
4. Loosen screw and remove clamp EGR pipe to valve.
5. Remove 4 bolts and EGR valve. Discard seal.

Refit

1. Clean EGR valve and mating face on inlet manifold.
2. Clean EGR pipe flange and EGR valve mating face.
3. Fit new seal to inlet manifold.
4. Fit EGR valve and tighten bolts evenly to 10 Nm.
5. Fit EGR pipe clamp and tighten screw.
6. Connect vacuum hose to EGR valve.
7. Fit intake ducting assembly.
👉 **FUEL DELIVERY SYSTEM - DIESEL, REPAIRS, Ducting - intake assembly.**
8. Connect battery earth lead.

Solenoid/modulator valve - EGR - Td4

🔑 17.45.04

Remove

1. Disconnect battery earth lead.
2. Remove inlet manifold gaskets.
👉 **MANIFOLDS & EXHAUST SYSTEMS - Td4, REPAIRS, Gaskets - induction manifold.**

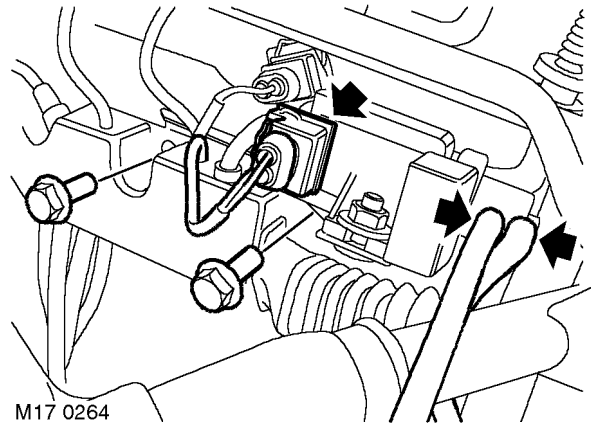

3. Disconnect multiplug from EGR solenoid valve.
4. Remove 2 bolts securing EGR solenoid bracket to cylinder block.
5. Identify and disconnect vacuum hoses.

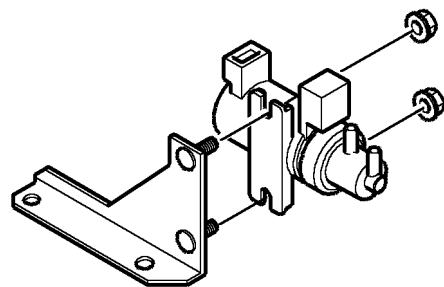

6. Remove 2 nuts and remove EGR solenoid valve from bracket.



Sensor - camshaft position (CMP)

🔑 18.30.24

Remove

1. Disconnect battery earth lead.

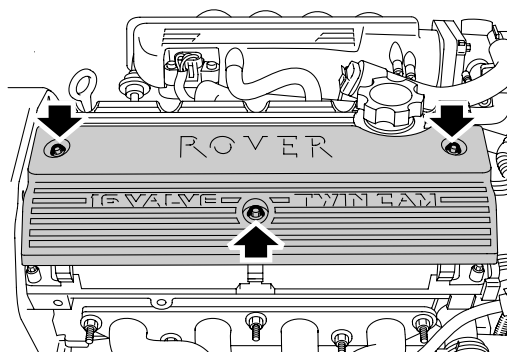

M18 0688

2. Remove three bolts securing coil cover to engine and remove coil cover.

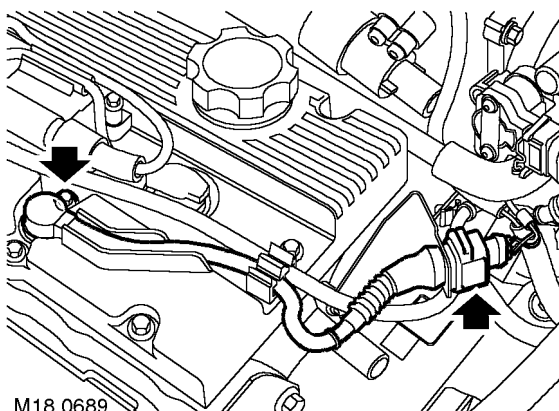

M18 0689

3. Release CMP sensor multiplug from bracket and disconnect multiplug.
4. Release sensor cable from clip.
5. Remove bolt securing CMP sensor and remove sensor.

Refit

1. Clean CMP sensor and mating face.
2. Fit CMP sensor, fit bolt and tighten to 10 Nm.
3. Connect CMP sensor multiplug and secure to bracket.
4. Position coil cover, fit bolts and tighten to 10 Nm.
5. Connect battery earth lead.

Sensor - manifold absolute pressure (MAP)

🔑 18.30.56

Remove

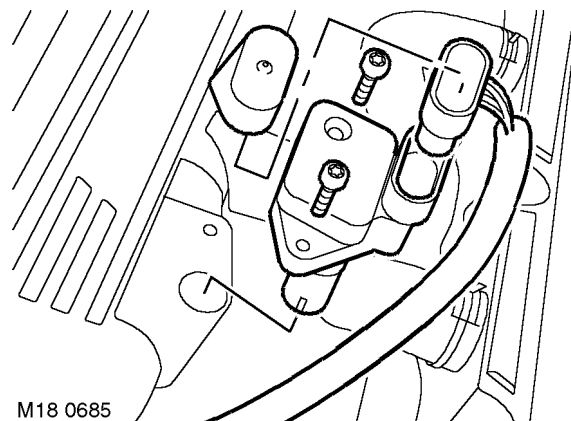

M18 0685

1. Remove cover and disconnect MAP sensor multiplug.
2. Remove 2 Torx screws securing MAP sensor to inlet manifold.
3. Remove MAP sensor from manifold.

Refit

1. Clean MAP sensor and manifold mating faces.
2. Fit MAP sensor to inlet manifold and tighten Torx screws.
3. Connect MAP sensor multiplug.
4. Fit MAP sensor multiplug cover.

ENGINE MANAGEMENT SYSTEM - SIEMENS

Sensor - combined - manifold absolute pressure/Intake air temperature (MAP/IAT)

🔑 19.22.26

Remove

1. Disconnect battery earth lead.
2. Remove engine acoustic cover.
👉 **ENGINE - K SERIES KV6, REPAIRS, Cover - engine acoustic.**

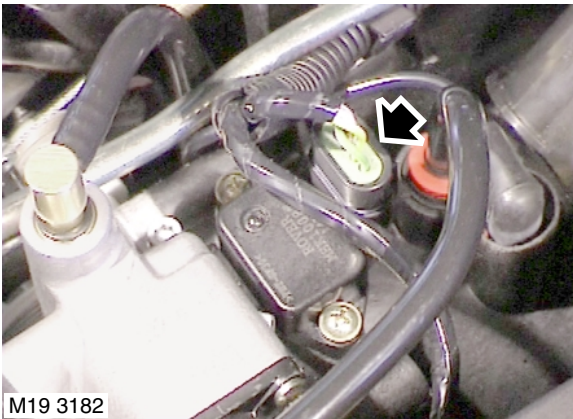

3. Disconnect multiplug from MAP/IAT sensor.

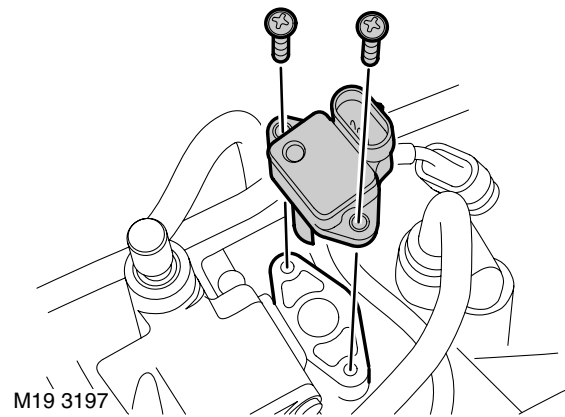

4. Remove 2 screws securing MAP/IAT sensor to inlet manifold chamber, remove sensor.

Refit

1. Clean MAP/IAT sensor and mating face on inlet manifold chamber.
2. Position MAP/IAT sensor, fit and tighten screws.
3. Connect multiplug to MAP/IAT sensor.
4. Fit engine acoustic cover.
👉 **ENGINE - K SERIES KV6, REPAIRS, Cover - engine acoustic.**
5. Connect battery earth lead.

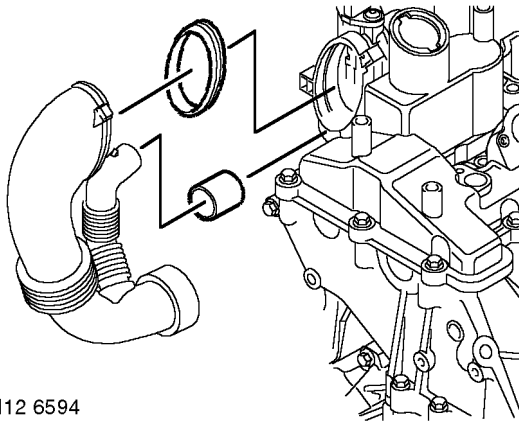

M12 6594

6. Remove seal, duct to MAF/IAT sensor.
7. Remove connector, engine breather pipe to air cleaner housing.

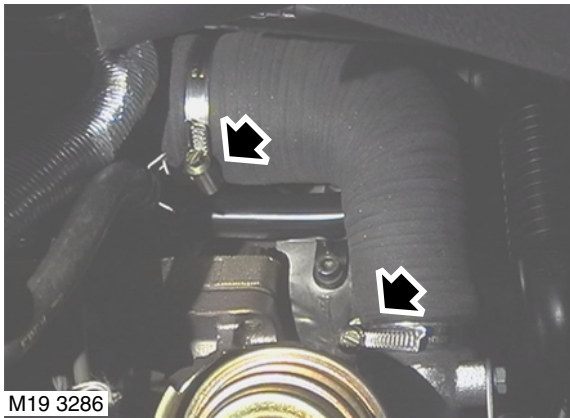

M19 3286

8. Loosen 2 clips and remove turbocharger outlet hose.

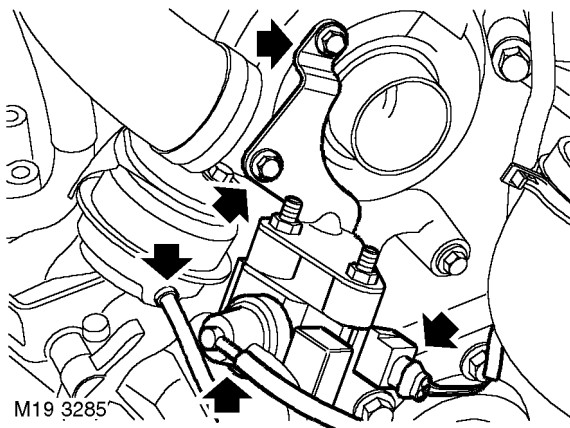

M19 3285

9. Disconnect multiplug from turbocharger boost control solenoid valve.

10. Disconnect vacuum hose from turbocharger boost control solenoid valve.
11. Disconnect vacuum hose from turbocharger boost control valve.
12. Remove 2 bolts and remove solenoid valve.

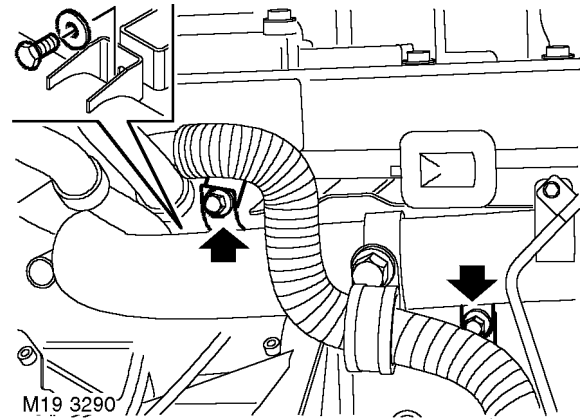

M19 3290

13. Remove 2 bolts turbocharger outlet pipe to coolant rail.
14. Loosen but do not remove remaining bolt, turbocharger outlet pipe to coolant rail.

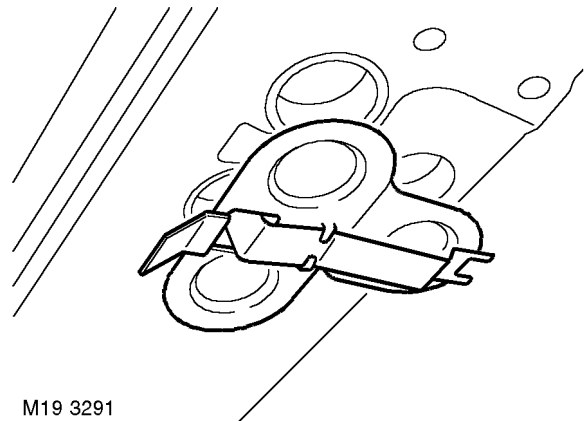

M19 3291

15. Remove access plate from heat shield.

FUEL DELIVERY SYSTEM - DIESEL

Refit

1. Position filler neck assembly, connect to hose, secure clip and fit tamper proof cover.
2. Fit bolt securing filler neck to body and tighten to 9 Nm.
3. Connect Lucar connector to fuel filler neck.
4. Position fuel tank vent pipe around filler neck.
5. Connect breather hose to filler neck, fit and secure clip.
6. Fit nuts securing fuel filler neck to body and tighten to 9 Nm.
7. Clip escutcheon to fuel filler neck.
8. Fit fuel filler cap.
9. Fit RH rear wheel arch liner.
 **EXTERIOR FITTINGS, REPAIRS, Liner - rear wheel arch.**
10. Connect battery earth lead.

Injector

 19.60.10

Remove

1. Disconnect battery earth lead.
WARNING: Fuel vapour is highly flammable and in confined spaces is also explosive and toxic. Always have a fire extinguisher containing foam, CO₂, gas or powder close at hand when handling or draining fuel.
2. Remove injector pipe.
 **FUEL DELIVERY SYSTEM - DIESEL, REPAIRS, Injector pipe.**
3. Cover engine air inlet tracts.
CAUTION: Before disconnecting or removing components, ensure the immediate area around joint faces and connections are clean. Plug open connections to prevent contamination.

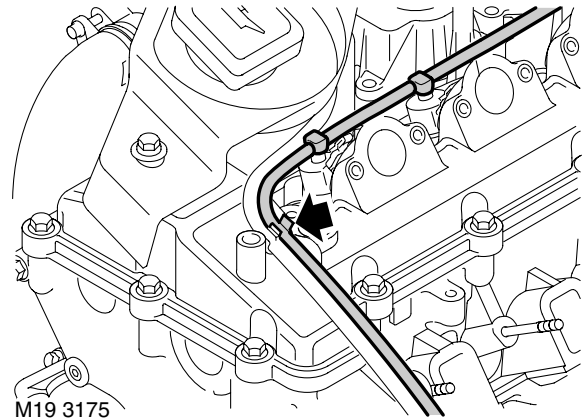

4. Release injector fuel return hose from clip on camshaft cover.



Air cleaner - K1.8

19.10.01

Remove

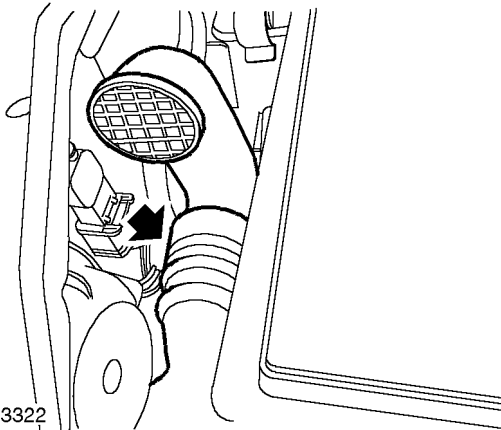

M19 3322

1. Release air intake duct from air cleaner.

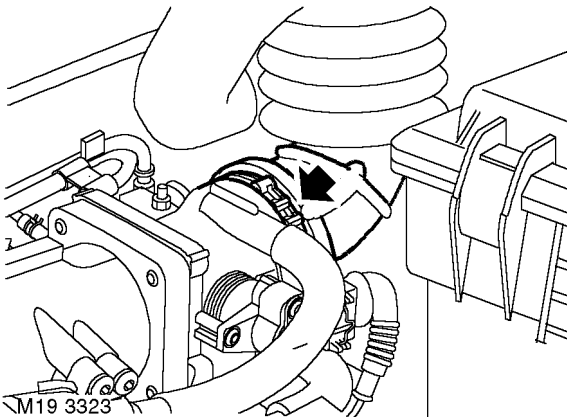

2. Remove clip and disconnect air intake hose from throttle housing.

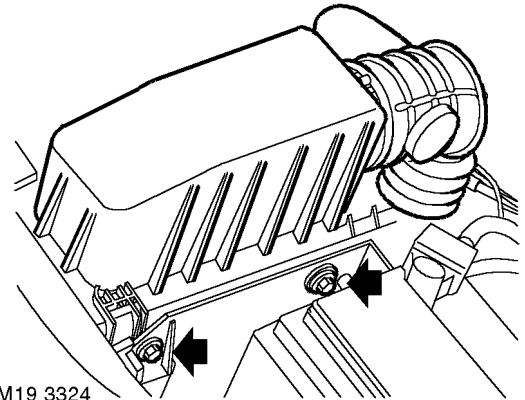

M19 3324

3. Remove 2 bolts securing air cleaner to battery tray.
4. Remove air cleaner assembly.

Refit

1. Position air cleaner assembly.
NOTE: Ensure bottom of air cleaner is located on peg.
2. Fit bolts and tighten to 9 Nm.
3. Connect air intake hose to throttle housing and secure with clip.
4. Connect air intake duct to air cleaner.

FUEL DELIVERY SYSTEM - PETROL

Sensor - heated oxygen (HO2S) - post cat - front - KV6

🔑 19.22.71

Remove

1. Raise front of vehicle.

WARNING: Do not work on or under a vehicle supported only by a jack. Always support the vehicle on safety stands.

2. Remove gear selector knob.

👉 **AUTOMATIC GEARBOX - JATCO, REPAIRS, Gear knob.**

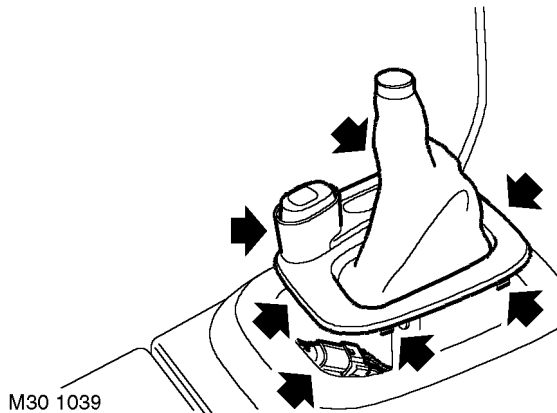

3. Release clips securing selector lever trim panel to centre console and move trim panel aside.
4. Disconnect HO2S multiplug from harness.

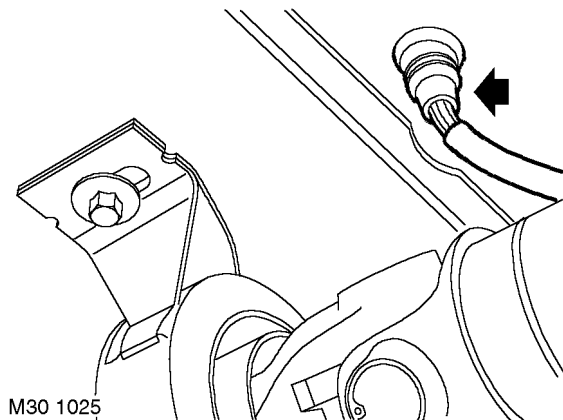

5. Release grommet and withdraw HO2S harness multiplug through grommet aperture.

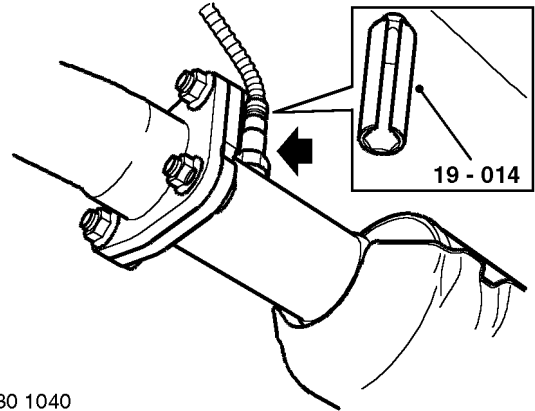

6. Remove HO2S.

Refit

1. Clean HO2S and mating face.
2. Fit HO2S and tighten to 55 Nm using tool **19-014**.
3. Feed HO2S harness through grommet aperture and secure grommet.
4. Connect HO2S multiplug.
5. Fit trim panel and gaiter to centre console and secure clips.
6. Fit gear selector knob.
👉 **AUTOMATIC GEARBOX - JATCO, REPAIRS, Gear knob.**
7. Remove stand(s) and lower vehicle.



Actuator unit - cruise control - KV6

🔑 19.75.05

Remove

1. Disconnect battery earth lead.
2. Remove engine acoustic cover.
🔧 **ENGINE - K SERIES KV6, REPAIRS, Cover - engine acoustic.**

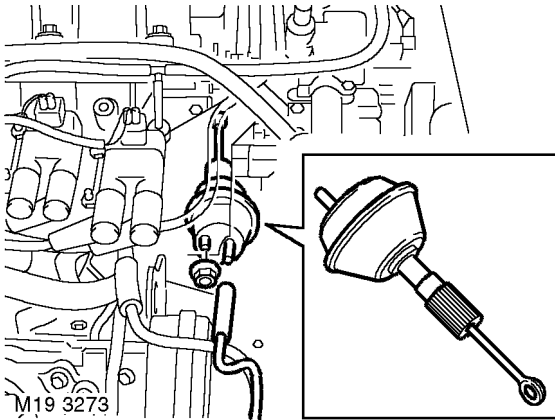

3. Disconnect vacuum hose from actuator.
4. Remove nut securing actuator to mounting bracket.
5. Release operating rod from throttle cam and remove actuator.

Refit

1. Position actuator and connect operating rod to throttle cam.
2. Position actuator into mounting bracket, fit and tighten nut.
3. Connect vacuum hose to actuator.
4. Check pull rod to retainer clearance, with lever fully returned, pull rod should just be held by retainer.
5. Release retainer by turning anti-clockwise, eliminate clearance then rotate retainer half turn clockwise. Check pull rod is just held and rotate retainer a further quarter turn clockwise to lock.
6. Fit engine acoustic cover.
🔧 **ENGINE - K SERIES KV6, REPAIRS, Cover - engine acoustic.**
7. Connect battery earth lead.

Vacuum pump - cruise control - KV6

🔑 19.75.06

Remove

1. Remove battery carrier.
🔧 **CHARGING AND STARTING, REPAIRS, Carrier - battery.**

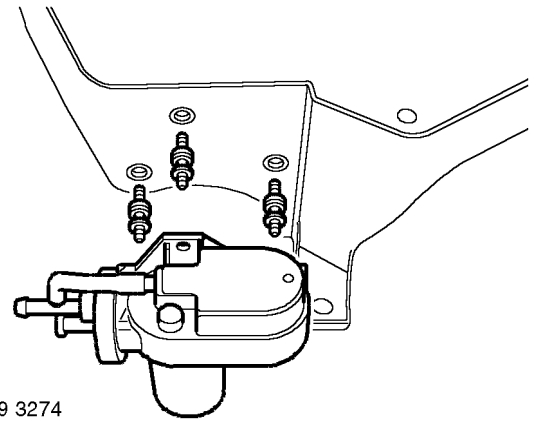

M19 3274

2. Release 3 rubber mountings securing vacuum pump to battery carrier and remove vacuum pump.
3. Remove 3 rubber mountings from vacuum pump.

Refit

1. Fit rubber mountings to vacuum pump.
2. Position vacuum pump to battery carrier and secure with rubber mountings.
3. Fit battery carrier.
🔧 **CHARGING AND STARTING, REPAIRS, Carrier - battery.**

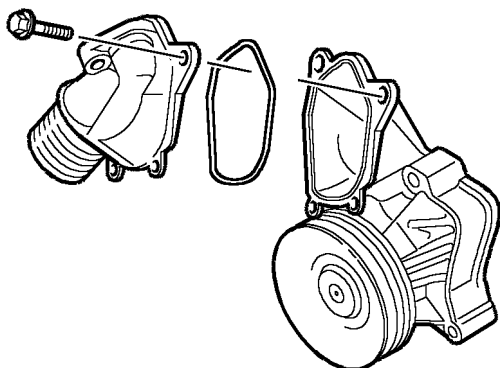

M26 0787

17. Fit road wheel(s) and tighten nuts to 115 Nm.
18. Fit camshaft cover gasket.
☞ **ENGINE - Td4, REPAIRS, Gasket - camshaft cover.**
19. Connect battery earth lead.
20. Refill cooling system.
☞ **COOLING SYSTEM - Td4, ADJUSTMENTS, Coolant - drain and refill.**

22. Remove 4 bolts and remove thermostat housing from coolant pump. Discard seal.

Refit

1. Clean mating face of thermostat housing and coolant pump.
2. Fit new seal to thermostat housing.
3. Fit thermostat housing to coolant pump and tighten bolts to 8 Nm.
4. Clean coolant pump and mating faces on engine and upper coolant rail.
5. Fit a new gasket and coolant pump to engine. Tighten bolts to 10 Nm.
6. Fit heatshield.
7. Fit new seal to coolant rail, fit rail to thermostat housing and tighten bolt to 8 Nm.
8. Tighten Allen screws securing heat shield to 8 Nm.
9. Tighten bolts securing coolant rail to 20 Nm.
10. Tighten bolt fuel rail to coolant rail to 10 Nm.
11. Fit turbocharger outlet hose and tighten clips.
12. Connect expansion tank hose to coolant rail and secure with clip.
13. Fit hose to coolant rail, connect to thermostat housing and secure hose with clips.
14. Fit hydramount.
☞ **ENGINE - Td4, REPAIRS, Hydramount - engine - RH.**
15. Remove engine lower steady.
☞ **ENGINE - Td4, REPAIRS, Engine steady - lower.**
16. Fit ancillary drive belt.
☞ **CHARGING AND STARTING, REPAIRS, Ancillary drive belt - Td4.**



Cooling fan and motor

🔑 26.25.22

Remove

1. Remove radiator.
 📖 **COOLING SYSTEM - K SERIES KV6, REPAIRS, Radiator assembly.**

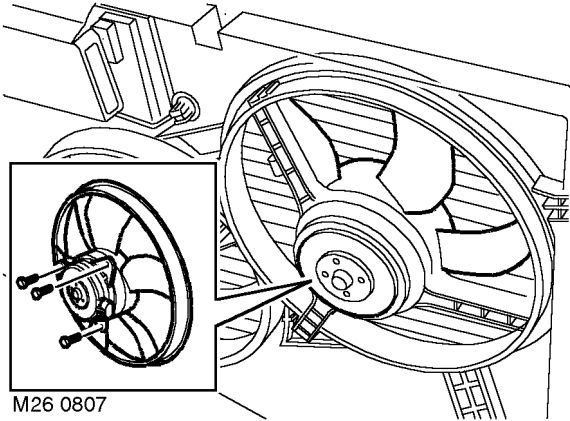

M26 0807

2. Remove 3 bolts securing LH cooling fan and motor assembly to fan cowl. Remove fan and motor assembly.

Refit

1. Position fan and motor assembly to fan cowl, fit and tighten bolts to 5 Nm.
2. Fit radiator.
 📖 **COOLING SYSTEM - K SERIES KV6, REPAIRS, Radiator assembly.**

Radiator assembly

🔑 26.40.01

Remove

1. Disconnect battery earth lead.
2. Remove engine acoustic cover.
 📖 **ENGINE - K SERIES KV6, REPAIRS, Cover - engine acoustic.**
3. Drain cooling system.
 📖 **COOLING SYSTEM - K SERIES KV6, ADJUSTMENTS, Coolant - drain and refill.**
4. **Models without A/C:** Remove bumper valance.
 📖 **EXTERIOR FITTINGS, REPAIRS, Bumper - assembly - front.**
5. **Models without A/C:** Remove 4 nuts and 4 bolts securing armature to body and remove armature.
6. **Models with A/C:** Remove A/C condenser.
 📖 **AIR CONDITIONING, REPAIRS, Condenser.**

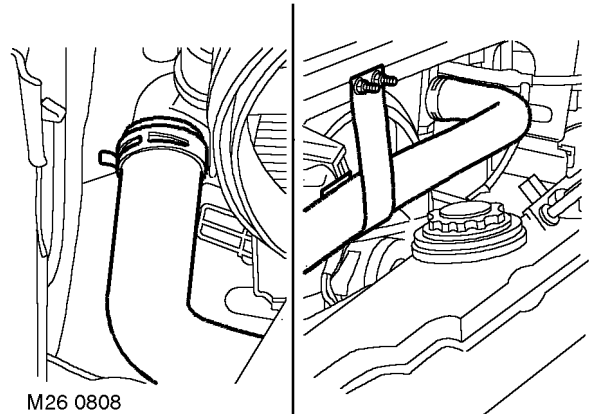

M26 0808

7. Release clips and remove top and bottom hoses.

CAUTION: Always fit plugs to open connections to prevent contamination.

8. Release clip and remove expansion hose from radiator.

CLICK HERE TO **DOWNLOAD** THE COMPLETE MANUAL

- Thank you very much for reading the preview of the manual.
- You can download the complete manual from: www.heydownloads.com by clicking the link below



- Please note: If there is no response to CLICKING the link, please download this PDF first and then click on it.

CLICK HERE TO **DOWNLOAD** THE COMPLETE MANUAL

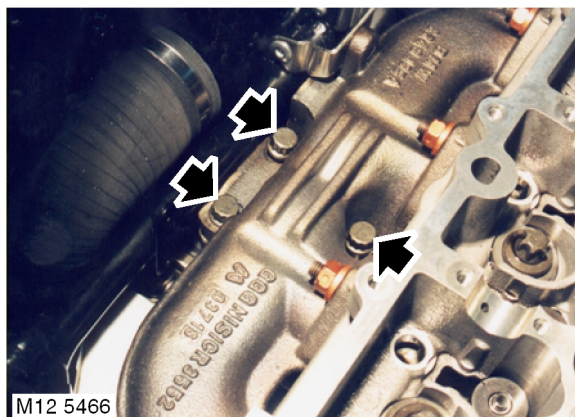

M12 5466

14. Remove 3 bolts turbocharger to exhaust manifold. Discard gasket.

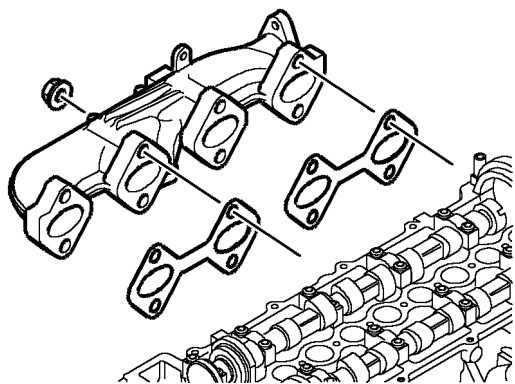

M30 1041

15. Remove 8 nuts and remove exhaust manifold. Discard gaskets.

Refit

1. Clean exhaust manifold and mating faces.
2. Use new gaskets and fit exhaust manifold to cylinder head.
3. Fit nuts securing exhaust manifold and tighten to 24 Nm.
4. Use new gasket, align turbocharger and tighten bolts to 50 Nm.
5. Clean EGR pipe and mating face.
6. Fit Torx screws EGR pipe to manifold and tighten to 22 Nm.
7. Tighten bolt EGR pipe to cylinder head to 20 Nm.
8. Fit heat shield.
9. Clean coolant rail and thermostat housing mating face.
10. Fit new seal to coolant rail, fit rail to thermostat housing and tighten bolt to 8 Nm.
11. Tighten Allen screws securing heat shield to 8 Nm.
12. Tighten bolts securing coolant rail to 20 Nm.
13. Tighten bolt fuel rail to coolant rail to 10 Nm.
14. Connect expansion tank hose to coolant rail and secure with clip.
15. Fit turbocharger outlet hose and tighten clips.
16. Fit camshaft cover gasket.
 - 👉 **ENGINE - Td4, REPAIRS, Gasket - camshaft cover.**
17. Fill cooling system.
 - 👉 **COOLING SYSTEM - Td4, ADJUSTMENTS, Coolant - drain and refill.**
18. Connect battery earth lead.



Heat shield - exhaust manifold - with A/C

🔑 30.15.09

Remove

1. Disconnect battery earth lead.
2. Turn steering on RH lock.

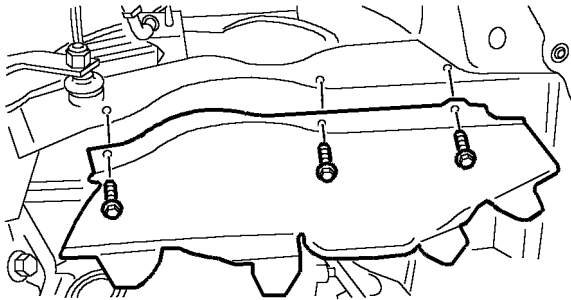

M12 6977

3. Remove 3 bolts securing RH splash shield to body and remove shield.

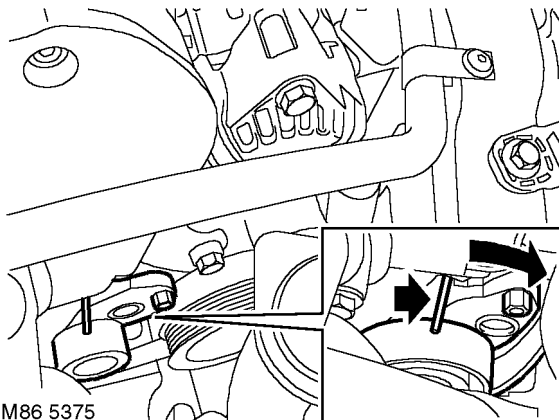

M86 5375

4. Fit a 13 mm spanner to hexagon on belt tensioner and rotate fully clockwise to release tension from drive belt.
5. To hold tensioner in this position, fit a suitable pin, not exceeding 3 mm diameter, through centre of hexagon into tensioner backplate.
6. Release auxiliary drive belt from alternator pulley.

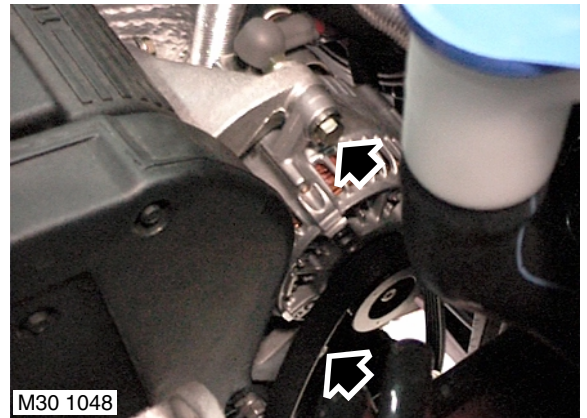

M30 1048

7. Remove top bolt securing alternator and loosen lower bolt.
8. Position alternator forward to clear heat shield.

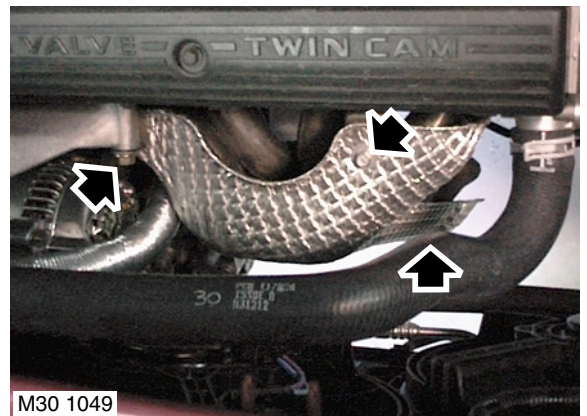

M30 1049

9. Remove nut and 2 bolts securing heat shield.
10. Remove heat shield.

Refit

1. Fit heat shield.
2. Locate heat shield to alternator bracket stud, fit nut and bolts. Tighten nut to 25 Nm and bolts to 10 Nm.
3. Align alternator to bracket and fit bolt.
4. Tighten both alternator bolts to 45 Nm.
5. Locate drive belt to pulleys, remove locking pin and release drive belt tensioner.
6. Ensure auxiliary drive belt is correctly located on all pulleys.
7. Fit splash shield and secure with bolts.
8. Straighten steering.
9. Connect battery earth lead.

MANIFOLDS & EXHAUST SYSTEMS - K SERIES KV6

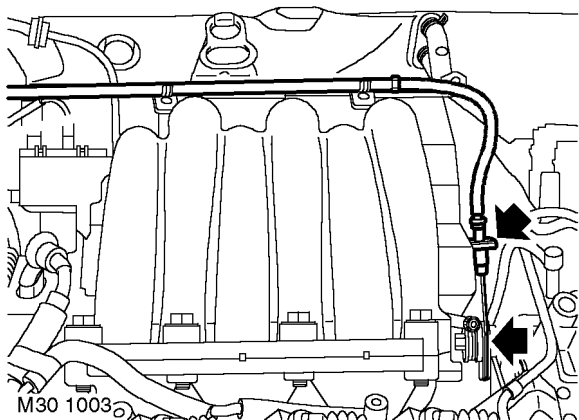

13. Release throttle cable from clips on harness brackets.
14. Release throttle cable from abutment bracket and disconnect cable from throttle body cam.

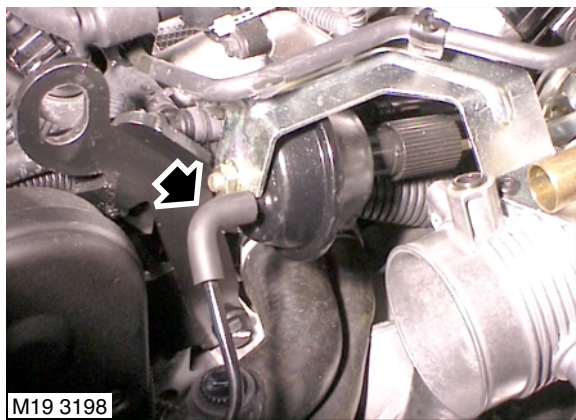

15. Disconnect cruise control actuator vacuum pipe.

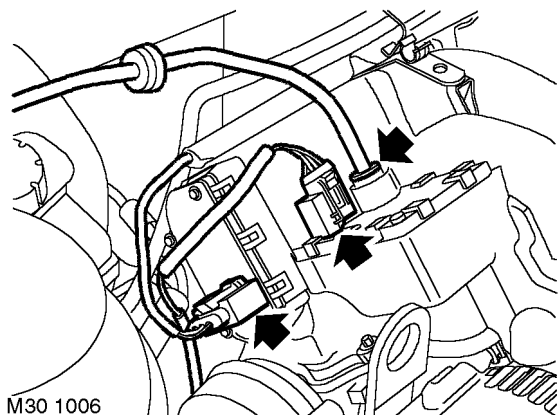

16. Depress locking collar and disconnect brake servo hose from inlet manifold chamber.

17. Disconnect multiplugs from VIS motors.

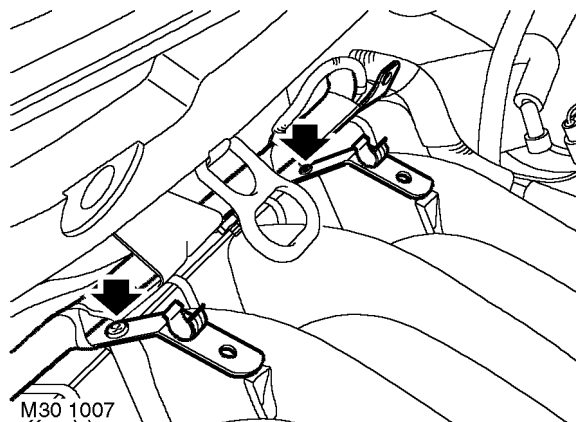

18. Remove 2 screws securing engine harness brackets to inlet manifold chamber and position harness aside.

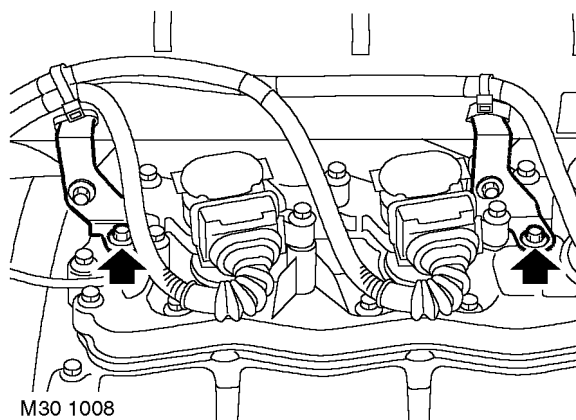



19. Remove 2 bolts securing inlet manifold chamber rear support brackets to RH camshaft cover.

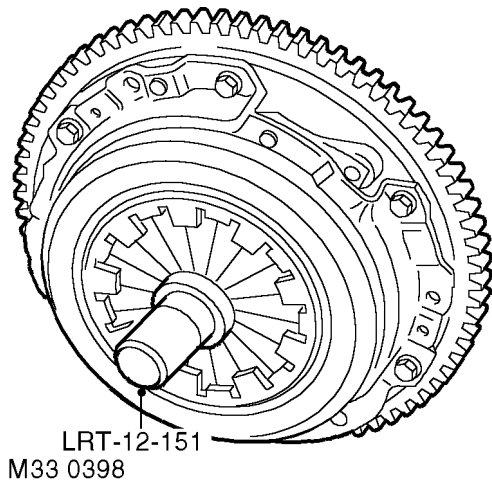

Refit

1. Clean pressure plate and flywheel, dowels and dowel holes.
2. Inspect flywheel for signs of scoring or other damage. Renew if worn or damaged.
3. Smear clutch drive plate splines with molybdenum disulphide grease.
4. Position drive plate to flywheel with 'FLYWHEEL SIDE' marking towards flywheel.



5. Fit pressure plate to flywheel and position clutch alignment tool, **LRT-12-151**.
6. Fit 6 bolts securing pressure plate to flywheel, tighten bolts sufficiently until drive plate is held in its central position. Remove **LRT-12-151** from pressure plate.
7. Working in a diagonal sequence, progressively tighten pressure plate bolts to 25 Nm.
8. Remove flywheel locking tool **12-190**.
9. Clean clutch release fork and release bearing guide sleeve.
10. Apply smear of Molybdenum disulphide grease to release bearing sleeve.
11. Fit release bearing to release fork and slide onto guide sleeve.
12. Operate clutch release lever to ensure that release bearing is correctly located on release fork and slides smoothly on guide sleeve.
13. Fit gearbox assembly.
 **MANUAL GEARBOX - PG1, REPAIRS, Gearbox.**
14. Connect battery earth lead.

Hydraulic assembly - RHD - K1.8

 **33.15.03**

Remove

1. Remove air cleaner assembly.
 **FUEL DELIVERY SYSTEM - PETROL, REPAIRS, Air cleaner - K1.8.**

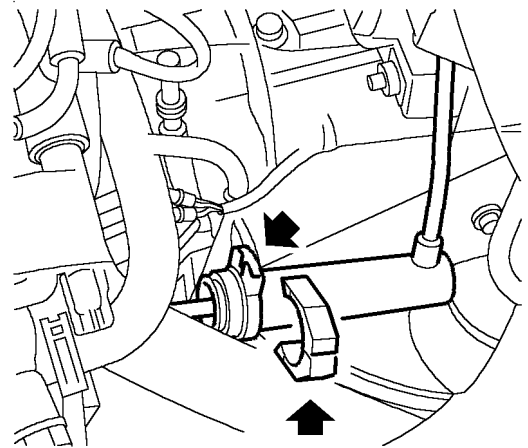

M33 0422

2. Remove 'C' clip from slave cylinder and release cylinder from support bracket.

26. Position harness to battery carrier and secure clips.
27. Fit starter motor.
☞ **CHARGING AND STARTING, REPAIRS, Starter motor - K1.8.**
28. Fit battery.
☞ **CHARGING AND STARTING, REPAIRS, Battery.**
29. Connect battery earth lead.

Oil seal - selector shaft

☞ 37.23.10

Remove

1. Remove underbelly panel.
☞ **EXTERIOR FITTINGS, REPAIRS, Panel - underbelly.**

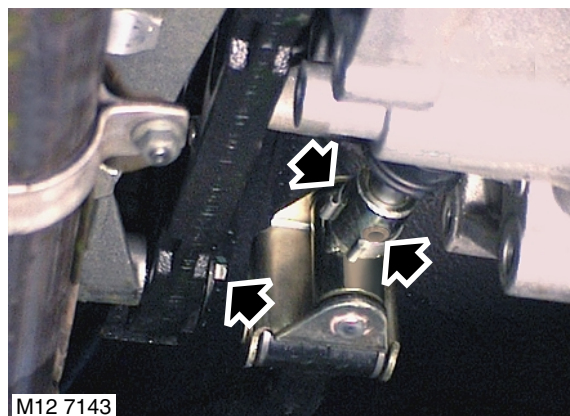

2. Remove bolt securing gear change steady to IRD support bracket, release steady from bracket and collect 2 washers.
3. Release gear change rod roll pin cover, remove and discard roll pin.
4. Release gear change rod from gearbox selector shaft.
5. Position container beneath gearbox to catch fluid loss.



Refit

1. Clean gear change oil seal recess, gear change cover and gearbox mating faces.

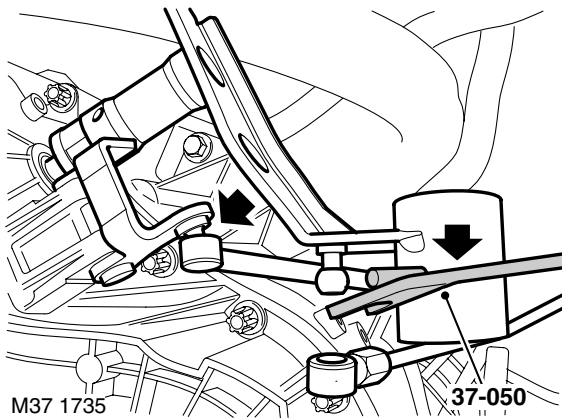

M37 1735

37-050

7. Use 37-050 and release gear change rods from quadrant.

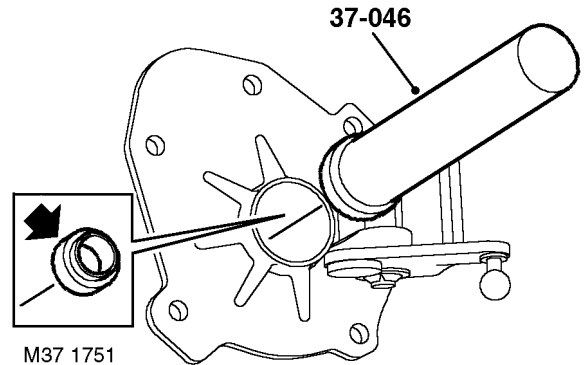

M37 1751

2. Using 37-046 fit new seal to gear change cover.
3. Lubricate gear change cover bearing with clean gearbox oil.

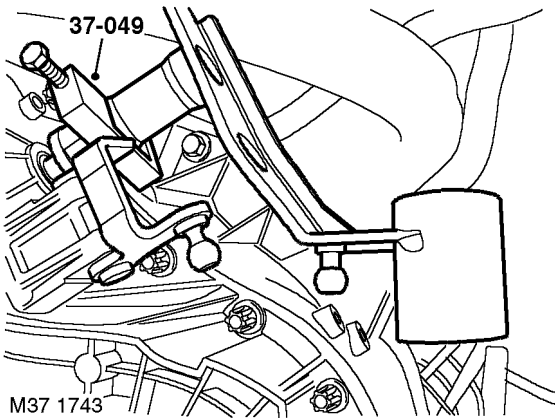

M37 1743

8. Using 37-049, carefully extract roll pin from gearchange selector shaft quadrant.
9. Remove selector quadrant from selector shaft.

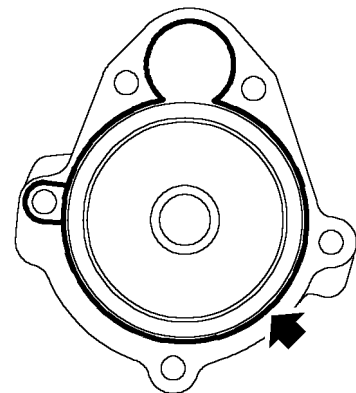

M37 1752

4. Apply a 1 mm bead of sealant to gearshift cover as illustrated.
5. Align gear change cover to selector shaft, fit new Torx bolts, evenly and progressively tighten to 25 Nm.
6. Fit quadrant to selector shaft, fit nylon block to slot in quadrant and align roll pin hole.
7. Fit 37-049 to gearchange quadrant, press new roll pin through selector shaft and remove tool. Check operation of selector mechanism.

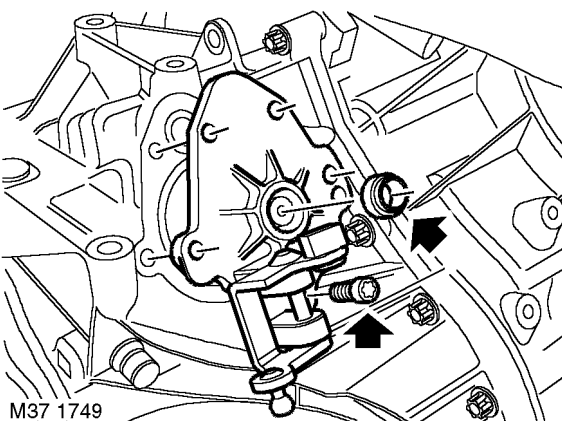

M37 1749

10. Remove and discard 5 Torx bolts securing gear change cover and remove cover.
11. Remove and discard oil seal from selector cover.

INTERMEDIATE REDUCTION DRIVE

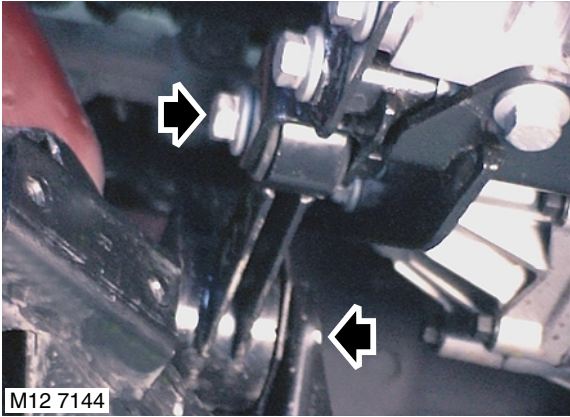

- 19. Remove bolt securing engine lower steady to bracket on sump.
- 20. Remove engine lower steady.

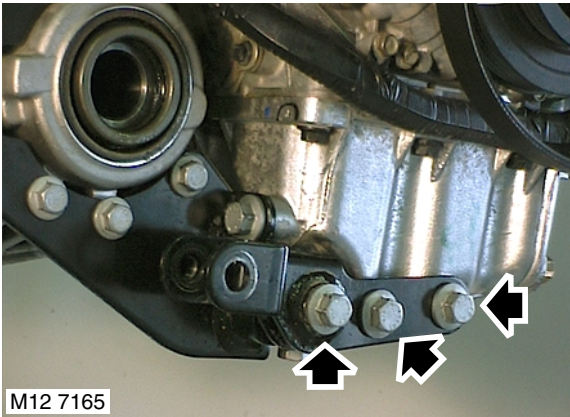

- 21. Remove 3 bolts securing lower engine steady bracket to sump and remove bracket.

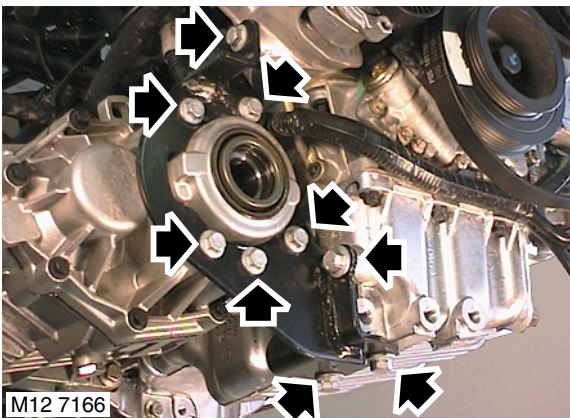

- 22. Remove upper bolt securing IRD support bracket to cylinder block.
- 23. Remove 5 bolts securing support bracket to IRD.

- 24. Remove 3 bolts securing IRD support bracket to sump and remove bracket.

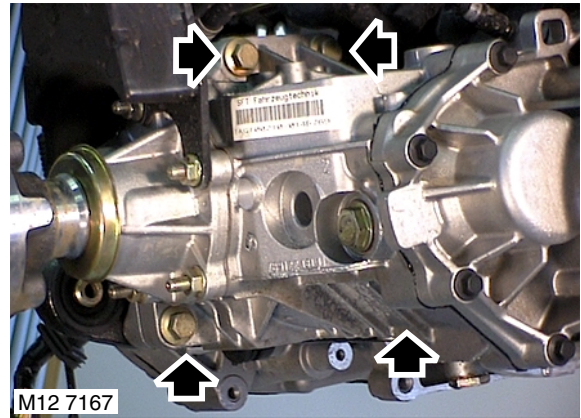

- 25. Remove 4 bolts securing IRD.
- 26. With assistance, release IRD from gearbox and remove.

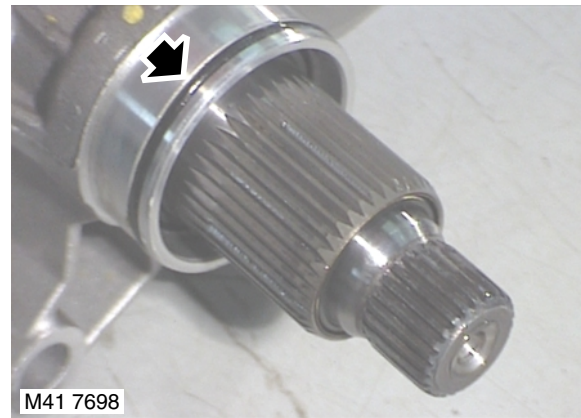

- 27. Remove and discard 'O' ring from IRD.

Refit

- 1. Clean mating faces of IRD and gearbox.
- 2. Lubricate and fit new 'O' ring
- 3. With assistance, fit IRD.
- 4. Fit bolts securing IRD to gearbox and tighten sufficiently only to pull mating faces of IRD and gearbox together at this stage.
- 5. Fit IRD support bracket and tighten bolts sufficiently only to pull mating faces together.
- 6. Final tighten bolts securing IRD to gearbox to 80 Nm.
- 7. Final tighten bolts securing IRD support bracket in following sequence:
 - 5 bolts securing IRD support bracket to IRD 50 Nm
 - 1 bolt securing support bracket to cylinder block to 45 Nm
 - 3 bolts securing support bracket to sump 45 Nm.



Seal - pinion gear

41.29.04

Remove

1. Remove pinion housing.
INTERMEDIATE REDUCTION DRIVE, REPAIRS, Seal - pinion gear housing - KV6.
CAUTION: Before dismantling the pinion housing, measure the turning torque on existing bearings.
2. Attach pinion housing to suitable mounting plate and secure mounting plate in vice.
3. Check pinion torque to turn figure.

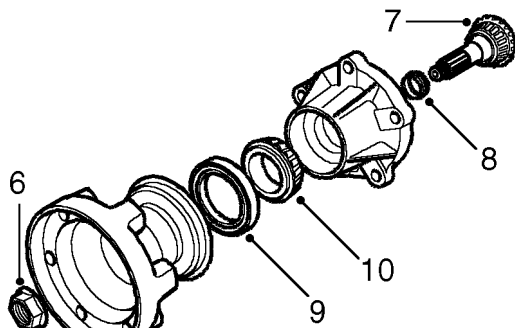

M41 7676

4. Reference mark pinion flange and pinion shaft for assembly purposes.
5. Restrain pinion flange using **LRT- 51-003**.
6. Remove and discard nut.
7. Position pinion housing onto press, fit suitable adaptor on end of pinion shaft, press pinion shaft from drive flange and housing.
8. Remove and discard collapsible spacer.
9. Using a suitable lever, remove pinion oil seal.
CAUTION: Take care to avoid damage to oil seal recess.
10. Remove pinion bearing inner race.

Refit

1. Clean pinion shaft, drive flange and housing.
2. Clean oil seal recess.
3. Lubricate and fit bearing to pinion housing.
4. Lubricate new seal.
5. Using a suitable adaptor, press seal into housing.
CAUTION: Oil seal must be flush with end of pinion housing.
6. Assemble pinion to housing using new collapsible spacer.
7. Lightly lubricate drive flange splines with Molybdenum Disulphide grease.
8. Align pinion to drive flange reference marks and press flange onto pinion shaft until a 2 mm clearance exists in bearings.
9. Fit pinion assembly to mounting plate and secure in vice.
10. Fit new pinion nut, hold pinion drive flange using **LRT-51-003** and tighten pinion nut to 150 Nm.
11. Check pinion torque to turn figure.
NOTE: Figure for new bearings is 180 to 200 Ncm.
If original bearing figure is above 20 to 30 Ncm and below new bearing figure, set to figure recorded.
If original bearing is below 20 Ncm set to 20 to 30 Ncm.
12. If turning torque is too low, carefully tighten nut and recheck reading. If turning torque is too high, pinion assembly will have to be dismantled and a new collapsible spacer fitted. Reassemble using new nut and recheck turning torque.
13. Check drive flange run-out using a Dial Test Indicator (DTI).
CAUTION: The drive flange run-out should not exceed 0.05 mm.
14. Remove pinion housing from vice and mounting plate.
15. Fit pinion housing.
INTERMEDIATE REDUCTION DRIVE, REPAIRS, Seal - pinion gear housing - KV6.

AUTOMATIC GEARBOX - JATCO

Refill

1. Clean area around filler plug.

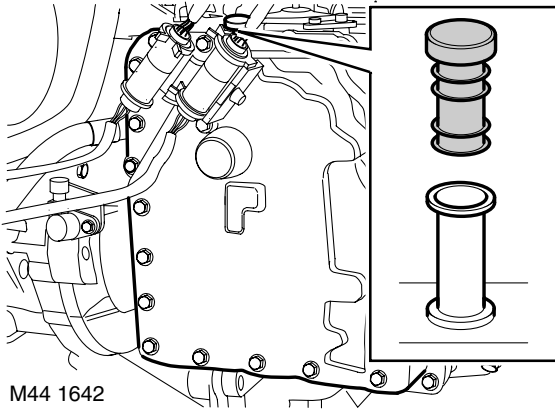

2. Remove filler plug.
3. Add 3.5 to 4 litres of the correct fluid through gearbox filler.
☞ CAPACITIES, FLUIDS AND LUBRICANTS, Lubrication.
4. Clean and fit filler plug.
5. Check and top-up fluid level.
☞ MAINTENANCE, MAINTENANCE, Automatic gearbox – JATCO.
6. Fit underbelly panel.
☞ EXTERIOR FITTINGS, REPAIRS, Panel - underbelly.

Selector cable - adjust

☞ 44.30.04

Adjust

1. Remove underbelly panel.
☞ EXTERIOR FITTINGS, REPAIRS, Panel - underbelly.

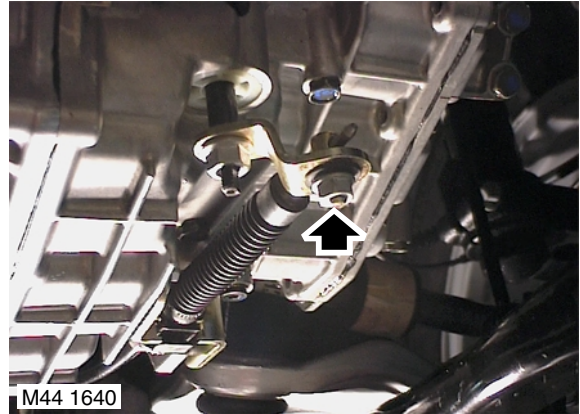

2. Loosen trunnion nut securing inner cable to selector lever.
3. Move gear change lever into 'P' position.
4. Move selector lever on gearbox fully clockwise to engage 'P' position.
5. Tighten trunnion nut to 6 Nm.
6. Fit underbelly panel.
☞ EXTERIOR FITTINGS, REPAIRS, Panel - underbelly.
7. Move selector lever through its working arc; from 'P' to '2' and back to 'P', checking that all gear positions are correctly selected.
8. Check that the engine will start in 'P' and 'N' positions and is inhibited when drive positions are selected.

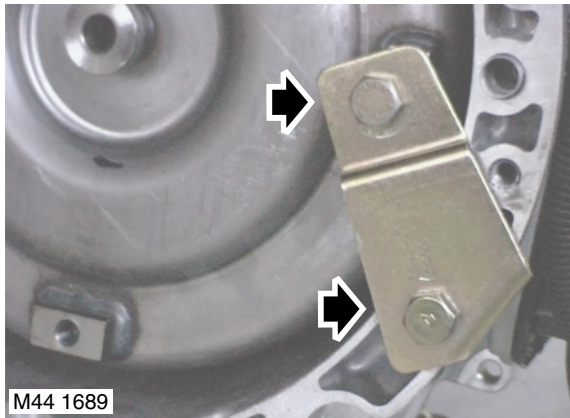

- 38. Fit converter retaining plate and secure with bolts.

Refit

- 1. Remove torque converter retaining plate.

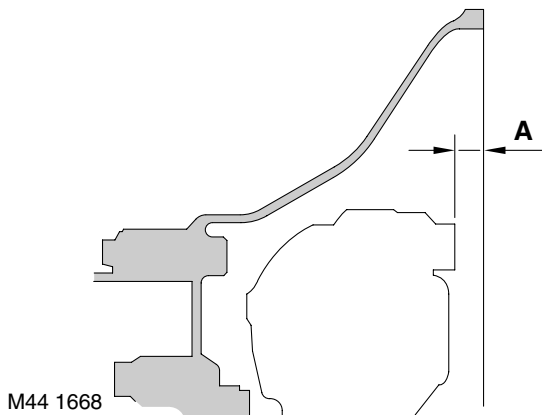





- 2. Ensure converter is fully located in oil pump drive by checking depth 'A' as illustrated. Depth A = 4 mm.
- 3. Clean gearbox to engine mating faces, dowels and dowel holes.
- 4. Fit gearbox assembly.
- 5. Fit bolts securing gearbox and tighten to 85 Nm.
- 6. Disconnect lifting equipment.
- 7. Clean CKP sensor and mating face.
- 8. Fit CKP sensor, fit bolt and tighten to 9 Nm.
- 9. Position fluid cooler, tighten M12 bolts to 85 Nm and M8 bolt to 25 Nm.
- 10. Connect hoses to fluid cooler.
- 11. Clean fluid cooler unions.
- 12. Lubricate new 'O' rings with clean transmission fluid and fit 'O' rings to fluid cooler hoses.

☞ CAPACITIES, FLUIDS AND LUBRICANTS, Lubrication.

- 13. Connect fluid cooler hoses to gearbox and tighten unions to 18 Nm.
- 14. Clean starter motor mating faces.
- 15. Position starter motor to gearbox, align CKP sensor multiplug bracket, fit and tighten bolts to 45 Nm.
- 16. Using gearbox bracket bolts, secure 44-026 lifting bracket to gearbox.
- 17. Position IRD cooling hose retainer, fit bolt and tighten to 25 Nm.
- 18. Align marks on drive plate to torque converter.
- 19. Fit bolts securing drive plate to torque converter and tighten bolts to 45 Nm.
- 20. Clean torque converter access plate.
- 21. Position access plate, fit bolts and tighten to 9 Nm.
- 22. Clean mating faces of IRD and gearbox.
- 23. Lubricate and fit new 'O' ring.
- 24. With assistance, fit IRD.
- 25. Fit bolts securing IRD to gearbox and tighten sufficiently only to pull mating faces of IRD and gearbox together at this stage.
- 26. Fit IRD support bracket and tighten bolts sufficiently only to pull mating faces together.
- 27. Final tighten bolts securing IRD to gearbox to 80 Nm.
- 28. Final tighten bolts securing IRD support bracket in following sequence: 5 bolts securing support bracket to IRD 50 Nm, 2 bolts securing support bracket to engine front mounting bracket 50 Nm, 3 bolts securing support bracket to sump 45 Nm.
- 29. Position lower engine steady, 'TOP' mark uppermost. Fit bolt but do not tighten at this stage.
- 30. Connect coolant hoses and secure with clips.
- 31. Connect breather hose to IRD housing.
- 32. Fit manifold heat shield and fit nut securing heat shield to pinion housing finger tight.
- 33. Fit bolts securing manifold heat shield to IRD support bracket and tighten to 9 Nm.
- 34. Fit nut securing heat shield to IRD and tighten to 45 Nm.
- 35. Final tighten nut securing manifold heat shield to IRD pinion housing to 25 Nm.
- 36. Clean exhaust manifold and mating face on cylinder head.
- 37. Fit exhaust manifold gasket.
- 38. Position exhaust manifold, fit nuts and progressively tighten, from centre outwards to 45 Nm.
- 39. Connect HO2S multiplug and secure to support bracket.

AUTOMATIC GEARBOX - JATCO



Refit

1. Clean gearbox closing panel.
2. Ensure closing plate is in position on engine and located on dowels.
3. Clean drive plate and ensure free from cracks and distortion.
4. Clean gearbox to engine mating faces, dowels and dowel holes.
5. Remove torque converter retaining plate.
6. Ensure torque converter is fully located in oil pump drive by checking depth 'A' as illustrated. Depth A = 27 mm.
7. Fit lifting chains to eyes and take weight of gearbox.
8. Raise gearbox and engage with dowels. Fit bolts securing gearbox to engine and tighten to 85 Nm.
9. Fit bolt securing closing plate to gearbox and tighten to 10 Nm.
10. Remove lifting chains from gearbox.
11. Fit mounting bracket to gearbox and tighten bolts to 85 Nm.
12. Raise engine, align bracket to mounting and tighten through bolt to 100 Nm.
13. Remove engine support chains.
14. Align torque converter to drive plate and tighten bolts to 45 Nm.
15. Fit grommet to access plate.
16. Fit trunnion to selector lever, fit inner cable to trunnion and secure outer cable to abutment bracket.
17. Adjust selector cable.
 **AUTOMATIC GEARBOX - JATCO, ADJUSTMENTS, Selector cable - adjust.**
18. Connect gearbox harness multiplugs and fit to clips.
19. Position earth lead to gearbox and tighten bolt to 25 Nm.
20. Connect intercooler hose and tighten clip.
21. Fit new circlip to LH drive shaft.
22. With assistance, fit LH drive shaft to gearbox, keep shaft square to prevent damage to oil seal in gearbox.
23. Fit IRD.
 **INTERMEDIATE REDUCTION DRIVE, REPAIRS, Intermediate reduction drive (IRD) unit - Td4.**
24. Fit starter motor.
 **CHARGING AND STARTING, REPAIRS, Starter motor - Td4.**
25. Fit fluid cooler.
 **AUTOMATIC GEARBOX - JATCO, REPAIRS, Fluid cooler - Td4.**
26. Fit intake ducting assembly.
 **FUEL DELIVERY SYSTEM - DIESEL, REPAIRS, Ducting - intake assembly.**
27. Connect battery earth lead.
28. Untie and close bonnet.

Fluid pan - reseal

 44.24.05

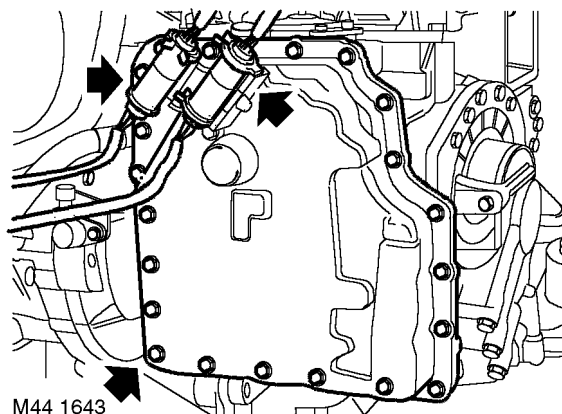

Remove

1. Drain gearbox fluid.
 **AUTOMATIC GEARBOX - JATCO, ADJUSTMENTS, Gearbox fluid - drain & refill.**
2. Remove fluid cooler.
 **AUTOMATIC GEARBOX - JATCO, REPAIRS, Fluid cooler - KV6.**



3. Release multiplugs from clips attached to fluid pan.
4. Remove 21 bolts securing fluid pan to gearbox.
5. Remove fluid pan.

Refit

1. Clean fluid pan and mating face on gearbox.
2. Apply liquid gasket to contact faces of fluid pan and gearbox.
3. Position fluid pan, fit bolts and tighten progressively to 7 Nm.
4. Secure multiplugs to clips.
5. Fit fluid cooler.
 **AUTOMATIC GEARBOX - JATCO, REPAIRS, Fluid cooler - KV6.**
6. Fill gearbox with fluid.
 **AUTOMATIC GEARBOX - JATCO, ADJUSTMENTS, Gearbox fluid - drain & refill.**



Gaiter - bell & joint - outer - front

🔑 47.10.03

Remove

1. Disconnect battery earth lead.
2. Raise front of vehicle.

WARNING: Do not work on or under a vehicle supported only by a jack. Always support the vehicle on safety stands.

3. Remove road wheel.
4. Remove drive shaft outer joint.

👉 **DRIVESHAFTS, REPAIRS, Bell & joint - outer - LH - front.**

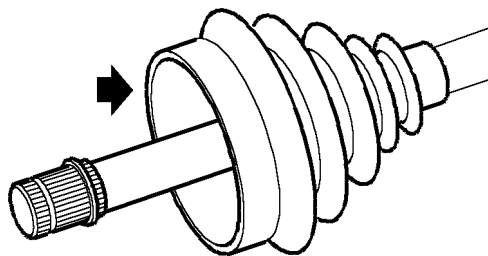

M47 0349

5. Slide gaiter from shaft.

Refit

1. Clean drive shaft.
2. Fit new gaiter to shaft.
3. Fit drive shaft outer joint.
👉 **DRIVESHAFTS, REPAIRS, Bell & joint - outer - LH - front.**
4. Fit road wheel(s) and tighten nuts to 115 Nm.
5. Remove stands and lower vehicle.
6. Connect battery earth lead.

Bell & joint - outer - LH - front

🔑 47.10.04

Remove

1. Disconnect battery earth lead.
2. Raise front of vehicle.

WARNING: Do not work on or under a vehicle supported only by a jack. Always support the vehicle on safety stands.

3. Remove road wheel.
4. Remove drive shaft.

👉 **DRIVESHAFTS, REPAIRS, Shaft with both joints - LH.**

5. Place drive shaft in vice.
6. Release both gaiter clips and discard.
7. Slide gaiter along shaft to gain access to outer joint.

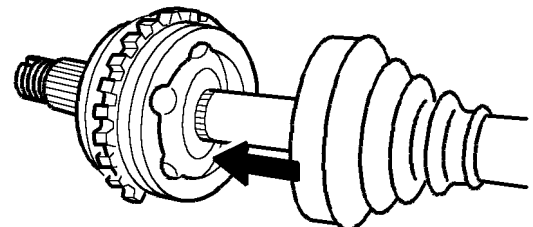

M47 0350

8. Using a suitable drift against the inner part of the joint, remove joint from shaft.
9. Inspect gaiter for damage and renew if necessary.

Refit

1. Clean drive shaft and gaiter.
2. Fit new circlip to drive shaft.
3. Position outer joint to shaft, use a screwdriver to press circlip into its groove and push joint fully onto shaft.
4. Apply grease from the sachet to the joint.
5. Position gaiter to joint and use a 'Band-it thriftool' **LRT-99-019** to secure the 2 new clips.
6. Fit drive shaft.
👉 **DRIVESHAFTS, REPAIRS, Shaft with both joints - LH.**
7. Fit front road wheels, fit and tighten nuts to 115 Nm.
8. Remove stands and lower vehicle.
9. Connect battery earth lead.

DRIVESHAFTS

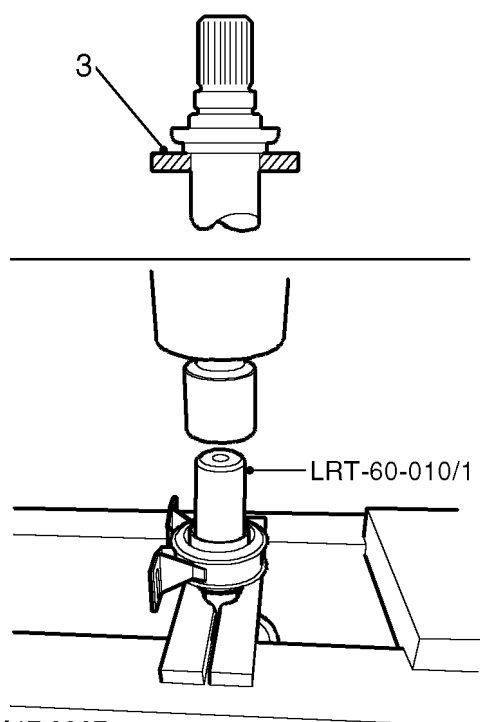

M47 0367

3. With assistance, position viscous coupling assembly onto press bed and locate the press bars onto collar on viscous coupling as shown.
4. Position **LRT- 60-010/1** onto bearing inner race, and with assistance, press support bearing onto viscous coupling.
5. Remove viscous coupling assembly from press.
6. Spin support bearing to confirm true running.
7. Fit front propeller shaft.
👉 **DRIVESHAFTS, REPAIRS, Propeller shaft - front.**
8. Fit rear propeller shaft.
👉 **DRIVESHAFTS, REPAIRS, Propeller shaft - rear.**



Alignment - rear wheel - check & adjust

🔑 57.65.06

Check

1. Ensure tyre pressures are correct and vehicle is at kerbside weight.
2. Roll vehicle backwards and forwards to relieve stresses in steering and suspension.
3. Ensure that wheel alignment equipment is properly calibrated.

NOTE: Only use equipment recommended for use by Land Rover.

4. Check front wheel alignment is within tolerance.
 📖 **GENERAL DATA, Steering.**
5. Check rear wheel alignment is within tolerance.
 📖 **GENERAL DATA, Steering.**

Adjust

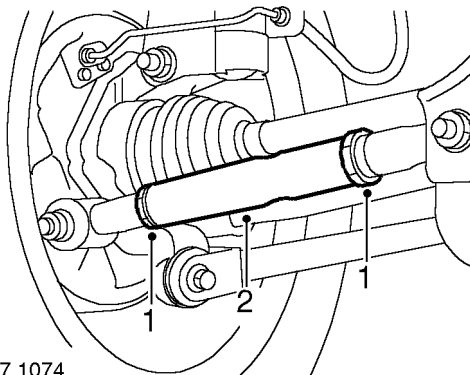

M57 1074

1. Hold turnbuckle on adjustable link and loosen both lock nuts.
2. Rotate turnbuckle to obtain correct alignment.
 📖 **GENERAL DATA, Steering.**
3. Hold turnbuckle and tighten lock nuts to 90 Nm.
4. Roll vehicle backwards and forwards to relieve stress in suspension.
5. Repeat check and adjust procedure on other side of vehicle.

Power steering - pressure test

🔑 57.90.10.01

Check

1. Position absorbent cloth to catch spillage.
2. Remove bolt securing PAS high pressure pipe clip to PAS pump.
3. Loosen union securing high pressure pipe to PAS pump and release pipe.

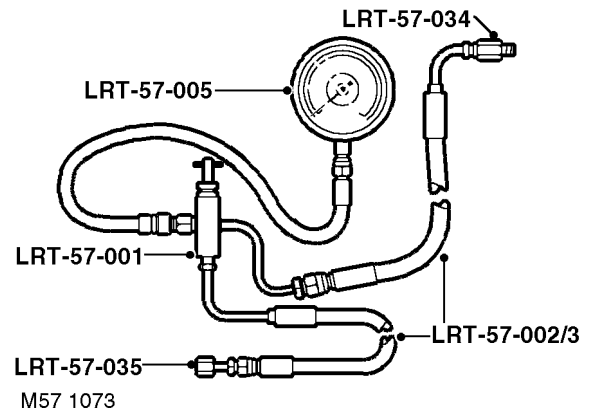

4. Fit adaptor **LRT-57-034** to high pressure port of PAS pump.
5. Fit adaptor **LRT-57-035** to existing high pressure hose.
6. Fit hose **LRT-57-002/3** to each adaptor.
7. Fit pressure gauge **LRT-57-005** to test valve **LRT-57-001**
8. Connect hoses **LRT-57-002/3** to **LRT-57-001** and tighten unions.
9. Ensure steering system and test equipment is free from leaks.
10. Maintain maximum fluid level during test.
11. With the test valve open, start the engine.
12. Pressure at idle should be between 5 and 7 bar.
13. With the engine at idle, slowly turn the steering wheel and hold on full lock.
14. Repeat procedure for other side.
15. Test pressure should rise significantly as steering wheel is rotated and continue to rise as full lock is approached, at full lock pressure should be:
 - **K1.8 models:** 90 to 100 bar.
 - **Td4 & KV6 models:** 112 to 120 bar. (maximum pump pressure)
16. With the engine at idle, release steering wheel. Pressure should read below 7 bar.

STEERING

Pump - steering - K1.8

🔑 57.20.14

Remove

1. Disconnect battery earth lead.
2. Raise front of vehicle.

WARNING: Do not work on or under a vehicle supported only by a jack. Always support the vehicle on safety stands.

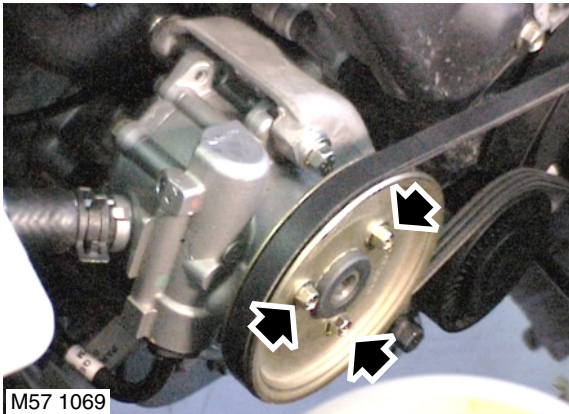

3. Loosen PAS pump pulley bolts.
4. Remove PAS pump drive belt.
👉 **STEERING, REPAIRS, Drive belt - K1.8.**
5. Position container to collect PAS fluid spillage.

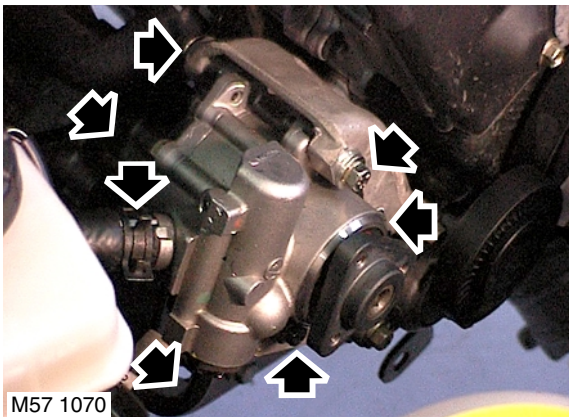

6. Release clip and disconnect fluid inlet hose from PAS pump.
CAUTION: Always fit plugs to open connections to prevent contamination.
7. Loosen union securing fluid outlet pipe, release outlet pipe remove and discard 'O' ring.
8. Remove 3 bolts securing PAS pump pulley to PAS pump and remove pulley.

9. Remove 5 bolts securing PAS pump to mounting bracket.
10. Remove PAS pump.

Refit

1. Position PAS pump and align to mounting bracket.
2. Fit bolts securing PAS pump to mounting bracket and tighten to 25 Nm.
3. Fit PAS pump pulley and align bolts holes. Ensure FRONT mark is facing outwards. Fit bolts finger tight.
4. Remove plug from fluid outlet hose.
5. Clean PAS pump and pipe union.
6. Using a new 'O' ring, align outlet pipe and tighten union.
7. Clean elbow on PAS pump.
8. Remove plug from fluid inlet hose, fit new clip and connect hose to PAS pump.
9. Remove container.
10. Clean pulley 'V's and tensioner pulley running surface.
11. Fit PAS pump drive belt.
👉 **STEERING, REPAIRS, Drive belt - K1.8.**
12. Tighten PAS pump pulley bolts to 10 Nm.
13. Connect battery earth lead.
14. Bleed PAS system.
👉 **STEERING, ADJUSTMENTS, Power assisted steering (PAS) system - bleed.**

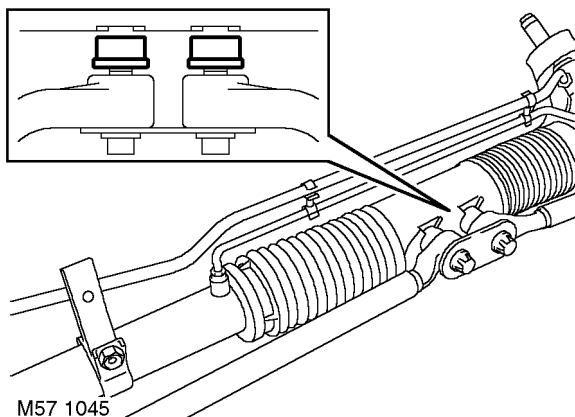

M57 1045

6. Fit spacer to rack.

CAUTION: Ensure spacers are aligned and fitted correctly.

7. Fit track rod to PAS rack.

8. Hold track rod parallel to PAS rack, fit new Torx bolt and tighten to 100 Nm.

9. **Td4 & KV6 models:** Fit steering rack.

STEERING, REPAIRS, Power steering rack.

10. Check and adjust front wheel alignment.

STEERING, ADJUSTMENTS, Front wheel alignment - check & adjust.

WARNING: Ensure all track rod pinch bolts are tightened to the correct torque on completion of the front wheel alignment check.

Steering wheel

57.60.01

Remove

1. Remove airbag module from steering wheel.
RESTRAINT SYSTEMS, REPAIRS, Air bag - steering wheel.

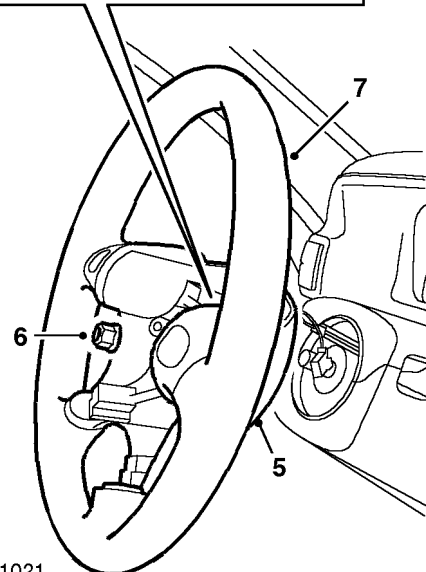
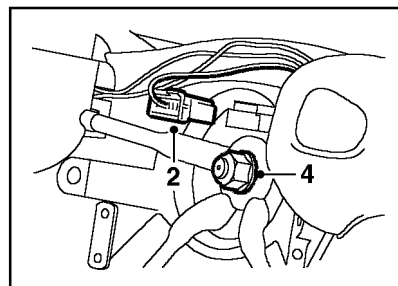

M57 1021

2. Disconnect multiplug from rotary coupler.
 3. Centralise steering wheel with road wheels in straight ahead position.
 4. Restrain steering wheel and loosen self locking nut securing steering wheel to column.
 5. Pull steering wheel from column splines.
 6. Remove and discard self-locking nut.
 7. Remove steering wheel.

FRONT SUSPENSION

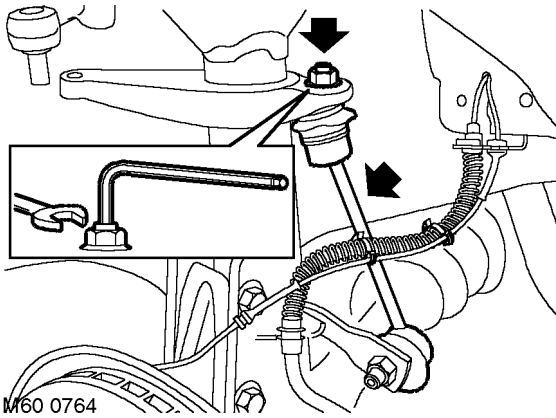

9. Remove upper nut from anti-roll bar link, release link and position aside.
CAUTION: Use a spanner and an Allen key to prevent ball joint rotating when undoing link.

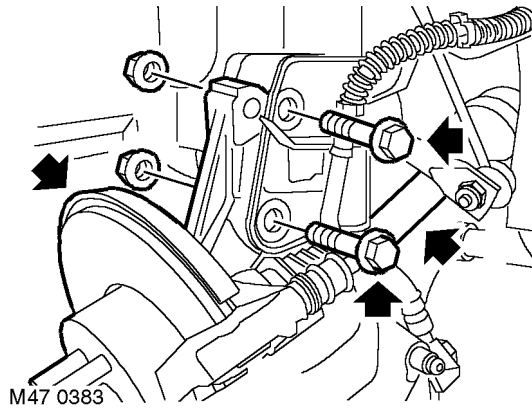

10. Remove 2 nuts and bolts securing hub to damper.
11. Release damper from hub.

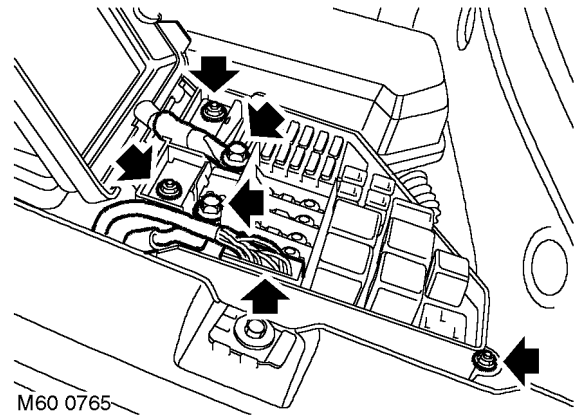

12. **LH side:** Remove 2 bolts securing positive and negative leads to fusebox.
13. **LH side:** Disconnect multiplug from engine compartment fuse box.
14. **LH side:** Release leads and position aside.
15. **LH side:** Remove 3 nuts securing fusebox and position fusebox aside.
16. **RH side:** Remove bolt securing coolant reservoir and position reservoir aside.

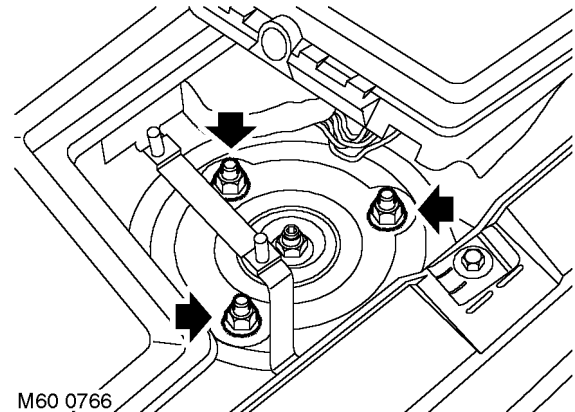

17. Reference mark top mounting in relationship to body.
18. Remove 3 nuts from damper top mounting and remove spring and damper assembly.

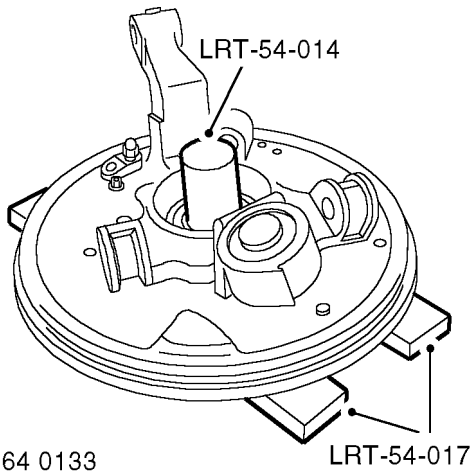

- 15.** Position hub assembly to press, support on tools **LRT-54-017** and press out drive flange using tool **LRT-54-014**.
- NOTE: Outer bearing track will remain on drive flange.*

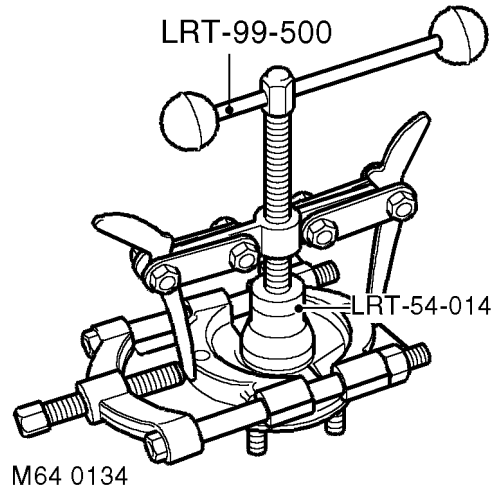

- 18.** Clamp both halves of a suitable bearing separator around inner track ensuring that inner lip fits in groove on inner track.
- 19.** Using tool **LRT-99-500** and thrust pad **LRT-54-014** withdraw inner track from drive flange.

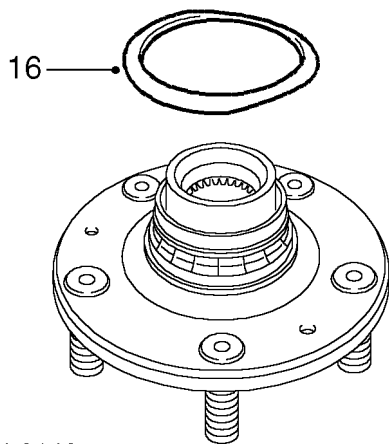

- 16.** Remove bearing sealing plate from inner track.
- 17.** Position drive flange in a vice.

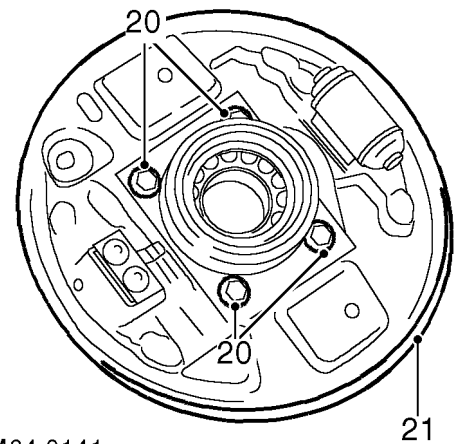

- 20.** Fit hub to vice and remove 4 bolts securing backplate to hub.
- 21.** Remove backplate.

REAR SUSPENSION

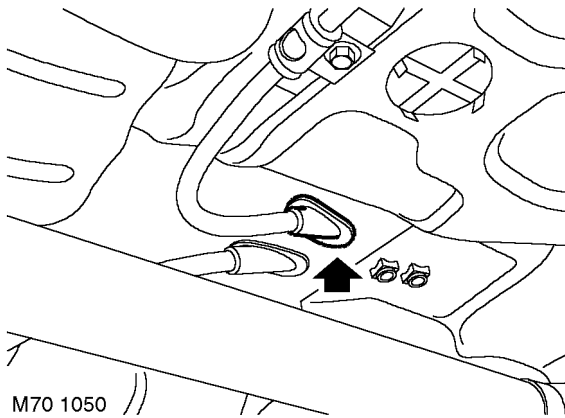

M70 1050

10. Release cable grommet from floor and pull cable from interior.
11. Remove rear brake shoes.
✎ **BRAKES, REPAIRS, Brake Shoes - rear set.**

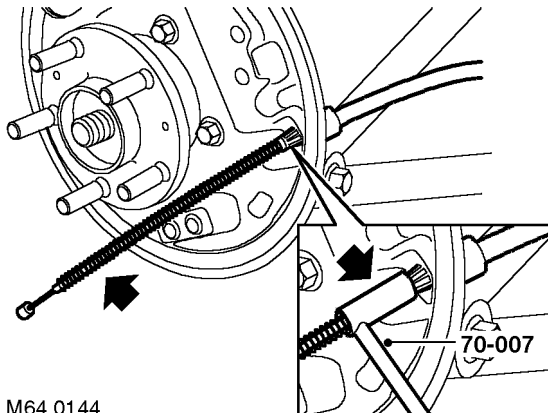

M64 0144

12. Using tool **70-007** release cable retainer from backplate and withdraw cable from vehicle.

Refit

1. Manoeuvre cable into position and secure floor grommet.
2. Fit and secure handbrake cable to backplate.
3. Fit brake shoes.
✎ **BRAKES, REPAIRS, Brake Shoes - rear set.**
4. Align cable clips, fit bolts and tighten to 22 Nm.
5. Secure cable in chassis clip.
6. Connect handbrake cable to equalizer.
7. Ensure spring is in place and fit equalizer to adjusting rod.
8. Fit cable adjusting nut.
9. Fit cable retaining plate, fit bolts and tighten to 22 Nm.
10. Adjust handbrake cable.
✎ **BRAKES, ADJUSTMENTS, Cable - handbrake - check and adjust.**
11. Fit ash tray and cigar lighter to rear console.
12. Fit road wheel(s).
13. Remove stands and lower vehicle.

BRAKES

Housing assembly - caliper - front

🔑 70.55.24

Remove

1. Raise front of vehicle.

WARNING: Do not work on or under a vehicle supported only by a jack. Always support the vehicle on safety stands.

2. Remove road wheel.
3. Clamp brake hose to prevent fluid loss.

CAUTION: An approved brake hose clamp must be used.

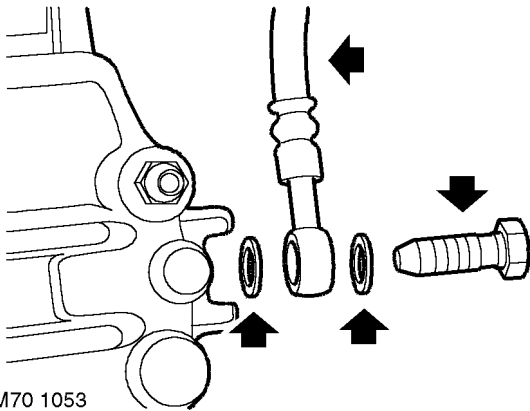

M70 1053

4. Remove banjo bolt securing brake hose to caliper and collect sealing washers.

CAUTION: Always fit plugs to open connections to prevent contamination.

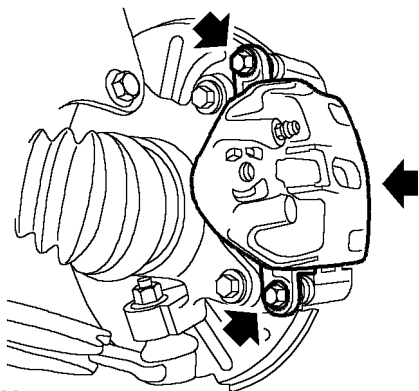

M70 1090

5. Remove 2 guide pins from caliper housing.
6. Remove caliper housing from caliper carrier.

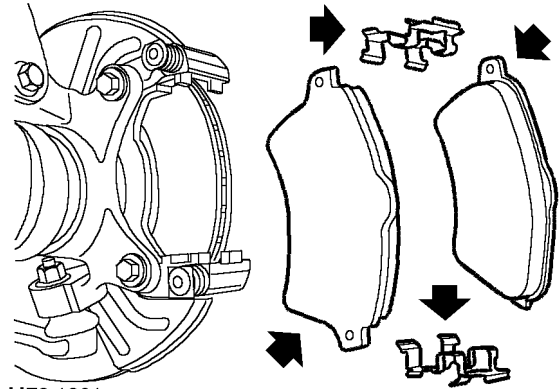

M70 1091

7. Remove 2 brake pads and retainers from caliper carrier.

Refit

1. Rotate disc by hand and scrape all scale and rust from around edge of disc. Clean location surfaces on caliper bracket.

WARNING: Do not use an air line to blow dust from brake assembly. Do not use petroleum based fluid as damage will occur to rubber components.
2. Clean dust from brake parts using brake cleaning fluid.
3. Fit pad retainers to caliper bracket.
4. Fit pads to caliper bracket.
5. Position caliper housing to carrier, align flats on guide pins with caliper housing.
6. Ensure flats on guide pins locate with lugs on caliper housing. Fit bolts and tighten to 27 Nm.
7. Clean banjo bolt and fit new sealing washers.
8. Position hose to caliper and tighten banjo bolt to 28 Nm.
9. Remove clamp from brake hose.
10. Bleed brakes.

👉 BRAKES, ADJUSTMENTS, Brake bleed.
11. Fit road wheel(s) and tighten nuts to 115 Nm.
12. Remove stands and lower vehicle.



Automatic belt assembly - front - 3 door

➔ 76.73.13

Remove

1. Remove seat base finisher.
SEATS, REPAIRS, Finisher - seat base - front - each.
2. Remove body side rear trim casing.
INTERIOR TRIM COMPONENTS, REPAIRS, Trim casing - body side - rear - LH.

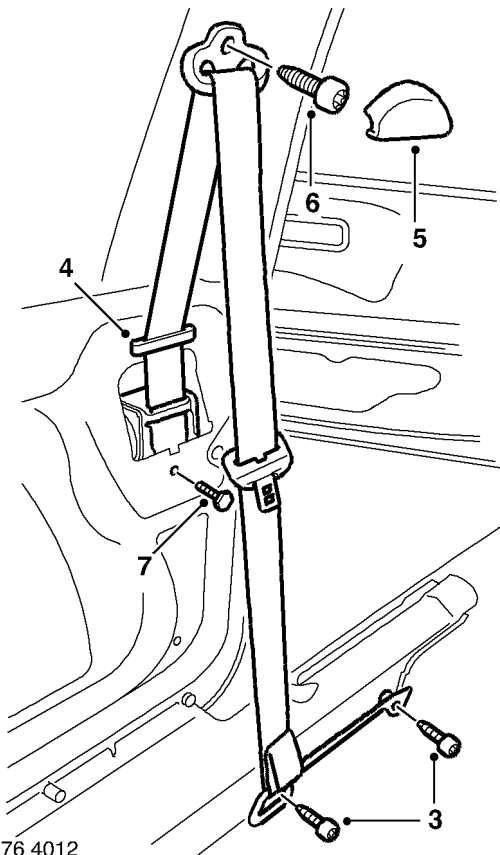

M76 4012

3. Remove 2 Torx bolts securing seat belt lower mounting and remove mounting from seat belt.
4. Release seat belt retaining strap.
5. Remove cover from upper mounting.
6. Remove Torx bolt from upper mounting.
7. Remove bolt from seat belt reel and remove reel.

Refit

NOTE: If the SRS component is to be replaced, the bar code of the new unit must be recorded.

1. Position reel and tighten bolt to 31 Nm.
2. Extend belt, position top mounting and tighten Torx bolt to 31 Nm.
3. Fit top mounting cover.
4. Secure belt retaining strap.
5. Fit lower mounting to seat belt, position mounting, fit and tighten Torx bolts to 40 Nm.
6. Fit body rear side trim casing.
INTERIOR TRIM COMPONENTS, REPAIRS, Trim casing - body side - rear - LH.
7. Fit seat base finisher.
SEATS, REPAIRS, Finisher - seat base - front - each.

RESTRAINT SYSTEMS

Air bag - fascia - passenger

🔑 76.74.02

Remove

WARNING: It is imperative that before any work is undertaken on the SRS system the appropriate information is read thoroughly.

WARNING: When removing, testing or installing an airbag module, do not lean directly over it.

1. Make the SRS system safe.

👉 **GENERAL INFORMATION,**
Supplementary restraint system
precautions.

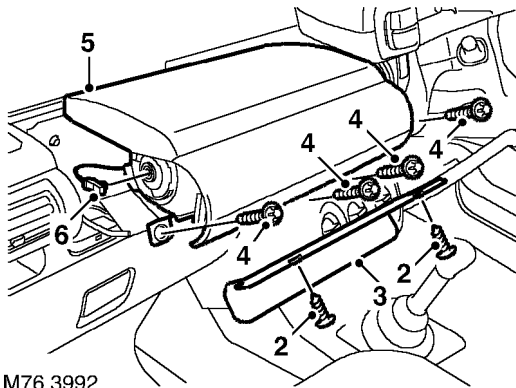

2. Remove 2 screws securing airbag lower finisher.
3. Remove finisher.
4. Remove 4 Torx bolts securing airbag module to fascia.
5. Release airbag from fascia.

CAUTION: Do not allow the airbag module to hang by the airbag harness.

6. Disconnect SRS connector from air bag module.
7. Remove airbag module.

WARNING: Store the airbag module with the deployment side uppermost. If it is stored deployment side down, accidental deployment will propel the airbag module with enough force to cause serious injury.

Refit

NOTE: If the airbag module is to be replaced, the bar code of the new module must be recorded.

1. Position airbag and fit connector.
2. Fit airbag to fascia and tighten Torx screws to 9 Nm.
3. Position airbag lower finisher and tighten screws.
4. Connect battery leads, earth lead last.

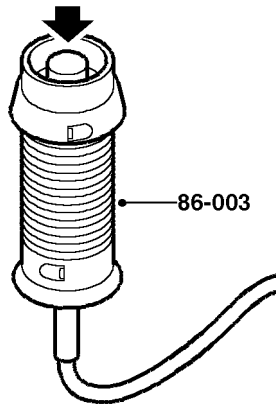

M76 4170

9. Press deployment tool operating button to deploy airbag module.
10. DO NOT return to airbag module for 30 minutes.

WARNING: During deployment parts of the airbag module become hot enough to burn you. Wait 30 minutes after deployment before touching the airbag module.

WARNING: Wear a face shield and gloves when handling a deployed airbag module. Wash your hands and rinse them well with water after handling a deployed airbag module.

11. Release passenger airbag module and disconnect deployment tool flylead **86-003-04**.
12. Remove passenger airbag module from vehicle.

 **RESTRAINT SYSTEMS, REPAIRS, Air bag - fascia - passenger.**

13. Place passenger airbag module in a strong plastic bag and seal bag.
14. Transport deployed airbag module to designated area for incineration.
NOTE: Do not transport deployed SRS components in the vehicle passenger compartment.
15. If the vehicle is being scrapped, scrap all remaining parts of the SRS system. **DO NOT** re-use or salvage any parts of the SRS system.
NOTE: If the vehicle is not being scrapped, ensure all dust/particle by-products of airbag deployment are removed from vehicle interior; vacuum all fabric surfaces and wipe all other surfaces with a damp cloth.

Pre-tensioner - front seatbelt - deployment using deployment tool SMD 4082/1 (in-vehicle)

 76.74.99

These guidelines are written to aid authorised personnel to carry out the safe deployment and disposal of seatbelt pre-tensioners when they are still fitted in the vehicle.

If a vehicle is to be scrapped and contains an undeployed pre-tensioner, the pre-tensioner must be manually deployed. This operation should only be carried out using the following recommended manual deployment procedure. Before deployment is started the deployment tool self test procedure should be carried out.

WARNING: Only use approved deployment equipment, and only deploy SRS components in a well ventilated designated area. Ensure SRS components are not damaged or ruptured before deployment. Notify the relevant authorities.

WARNING: Always remove the ignition key from the ignition switch, disconnect the vehicle battery and wait 10 minutes before commencing work on the SRS system.

WARNING: Only personnel who have undergone the appropriate training should undertake deployment of airbag and seat belt pre-tensioner modules.

WARNING: When removing, testing or installing a seatbelt pre-tensioner, do not lean directly over it or block the end of the piston tube.

Deploy

1. Carry out deployment tool **SMD 4082/1** self test.

 **RESTRAINT SYSTEMS, REPAIRS, Airbag deployment tool SMD 4082/1- self test procedure.**

2. Slide seat fully rearwards to access pre-tensioner harness connector.

DOORS

Rubber/felt - glass channel - rear door

🔑 76.31.14

Remove

1. Remove rear door glass.
👉 **DOORS, REPAIRS, Glass - rear door.**

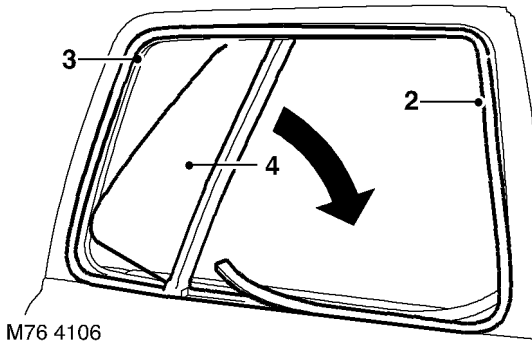

M76 4106

2. Release seal from flange. Remove lower section first, then front vertical section, followed by top section.
3. Release top corner of quarter light from frame. Rotate quarter light and seal, release rest of seal from flange and remove quarter light and seal from door.
4. Remove quarter light from seal.

Refit

1. Fit quarter light to seal.
2. Lubricate seal around quarter light with soft soap.
3. Position quarter light and seal to flange at bottom rear corner of window aperture and rotate into top rear corner. Using dividing bar, pull quarter light rearwards to locate seal around quarter light on flange.
4. Starting at top of divider bar, push seal onto top flange and locate in top front corner. Ensure radius of seal matches door profile.
5. Ease seal away from front flange and locate seal in bottom front corner. Ensure radius of seal at bottom front corner matches profile of door and that seal is still correctly located in top front corner, then push seal onto front flange.
6. Push seal onto bottom flange.
7. Fit rear door glass.

👉 **DOORS, REPAIRS, Glass - rear door.**

Glass - tail door

🔑 76.31.20

Remove

1. Remove tail door plastic sheet.
👉 **DOORS, REPAIRS, Plastic sheet - tail door.**

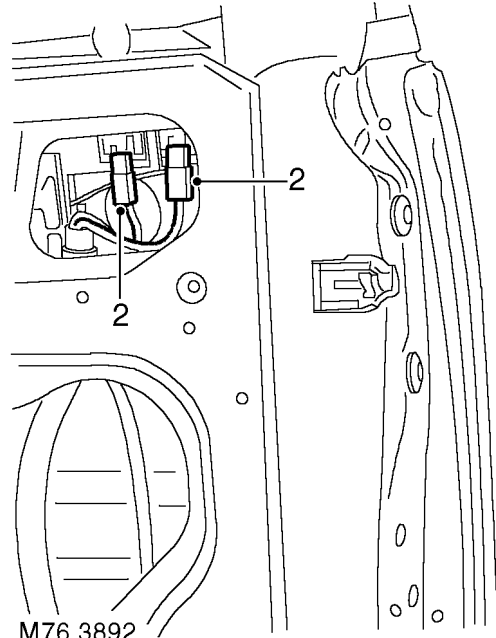

M76 3892

2. Disconnect 2 Lucars from heater element.
3. Lower screen to access clamp bolts.
4. Loosen both clamp bolts, release and remove rear screen.



Plastic sheet - rear door

🔑 76.34.28

Remove

1. Remove rear door speaker.
IN CAR ENTERTAINMENT, REPAIRS, Speaker - rear - 5 door.

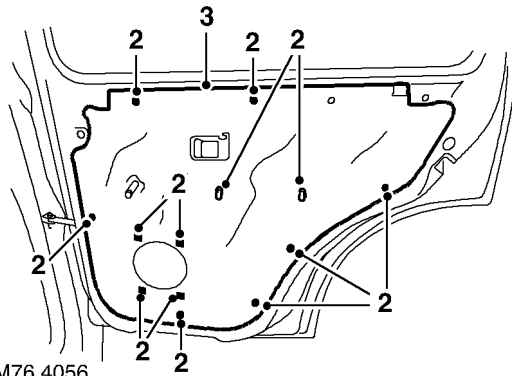

M76 4056

2. Noting their fitted position, remove 7 trim stud retainers, 2 door pull screw retainers and 4 speaker screw retainers.
3. Release and discard plastic sheet.

Refit

1. Clean door contact area with white spirit.
2. Position NEW plastic sheet to door and seal in position, by applying hand pressure to centre bottom of sheet first then move out from this point in both directions applying an even pressure to the seal, smooth out any creases.
CAUTION: It is crucial that no creases are present along the base of the plastic sheet.
3. Fit trim stud retainers and screw retainers to door.
4. Fit rear door speaker.
IN CAR ENTERTAINMENT, REPAIRS, Speaker - rear - 5 door.

Latch - front door - 3 door

🔑 76.37.12

Remove

1. Remove upper plastic sheet.
DOORS, REPAIRS, Plastic sheet - front door - upper - 3 door.

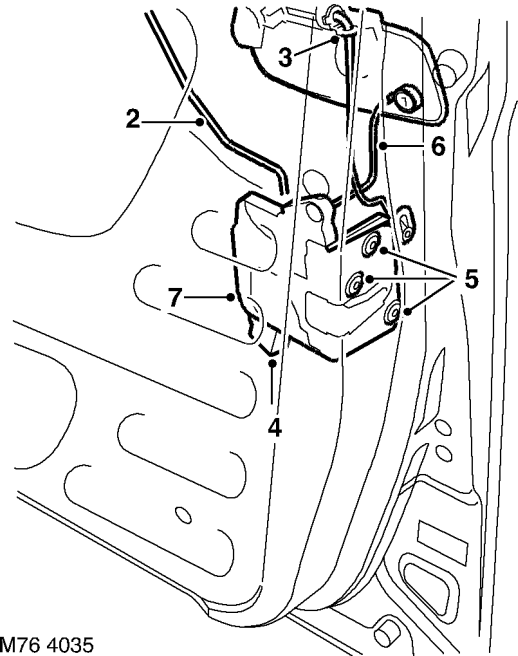

M76 4035

2. Release sill button lock rod from door latch.
3. Remove control rod from exterior handle.
4. Disconnect multiplug from latch.
5. Remove 3 Torx screws securing latch to door.
6. On drivers door, release door lock barrel paddle from latch.
7. Remove latch from aperture.

EXTERIOR FITTINGS

Refit

1. Fit side repeater lamp to front wing.
2. Position front wing to body.
3. Connect repeater lamp multiplug.
4. Align front wing to body.
5. Fit bolts securing rear wing to 'A' post, top of wing and front of wing, but do not tighten at this stage.

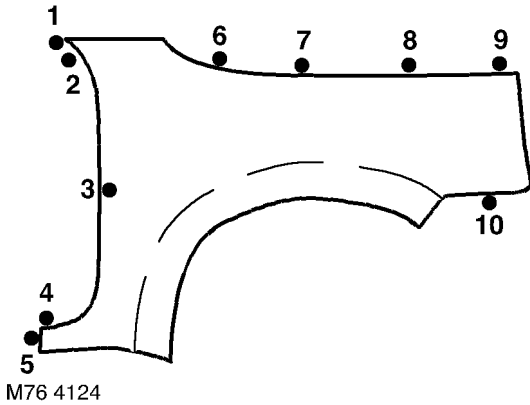

6. Align wing and tighten bolts in sequence shown to 5 Nm.
7. Align wheel arch liner to rear of wing.
8. Fit screw securing wheel arch liner to under side of wing.
9. Fit lower sill finisher.
 EXTERIOR FITTINGS, REPAIRS, Finisher - sill - lower.
10. Fit front mud flap.
 EXTERIOR FITTINGS, REPAIRS, Mud flap - front.

Liner - front wheel arch

76.10.48

Remove

1. Raise front of vehicle.
WARNING: Do not work on or under a vehicle supported only by a jack. Always support the vehicle on safety stands.
2. Remove road wheel.
3. Remove front mud flap.
 EXTERIOR FITTINGS, REPAIRS, Mud flap - front.

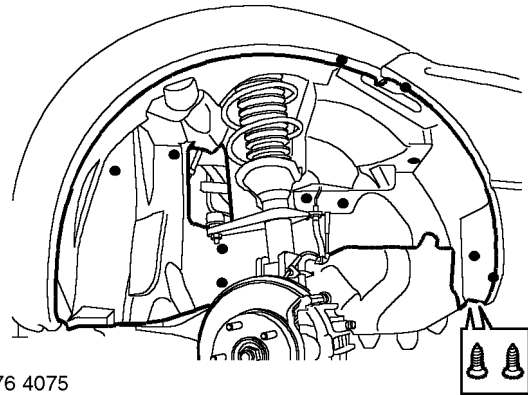

4. Remove 3 screws securing wheel arch liner to wing and bumper.
5. Remove 8 retaining studs securing wheel arch liner to inner wing.
6. Release and remove wheel arch liner.

Refit

1. Fit wheel arch liner.
2. Fit retaining studs securing wheel arch liner to inner wing.
3. Fit and tighten screws securing wheel arch liner to wing and bumper.
4. Fit front mud flap.
 EXTERIOR FITTINGS, REPAIRS, Mud flap - front.
5. Fit road wheel(s) and tighten nuts to 115 Nm.
6. Remove stand and lower vehicle.



Body quarter vent assembly - 3 door

76.81.24

Remove

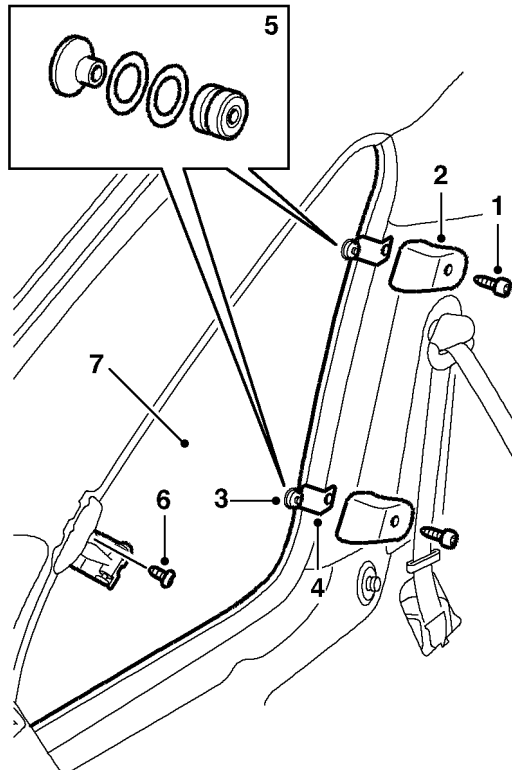

M76 4009

1. Remove 2 Torx screws securing vent hinge covers.
2. Remove covers from hinges.
3. Remove 2 screws securing hinges to vent.
4. Remove hinges from vent.
5. Remove nuts from vent and discard sealing washers.
6. With assistance remove screw securing vent catch to body.
7. Remove vent.

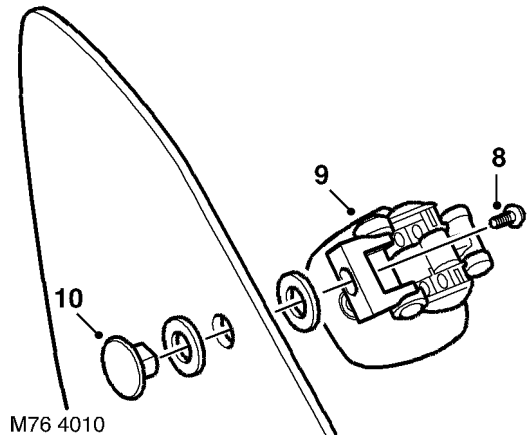

8. Remove screw securing catch to vent.
9. Remove catch from vent.
10. Remove nut from vent and discard sealing washers.

Refit

1. Fit nut and new sealing washer to vent.
2. Fit catch and tighten screw.
3. With assistance fit vent and tighten catch screw.
4. Using new sealing washers fit nuts and hinges to vent. Fit and tighten hinge screws to vent.
5. Fit hinge covers and tighten Torx screws.

INTERIOR TRIM COMPONENTS

Console - rear

76.25.04

Remove

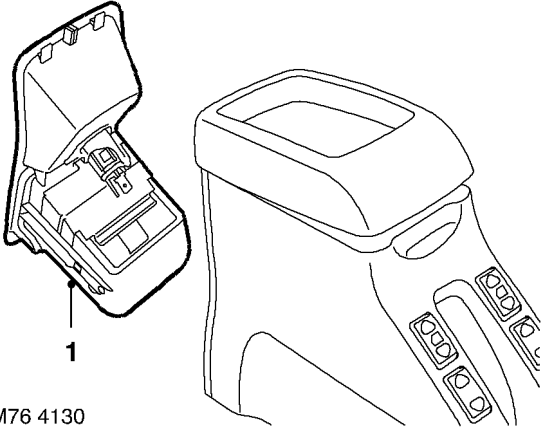

1. Release rear ash tray panel from rear console, disconnect multiplug from power socket and remove panel.

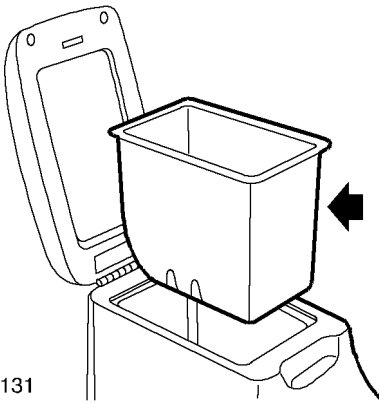

2. Remove oddments tray liner, raise cubby box lid and remove cubby box.

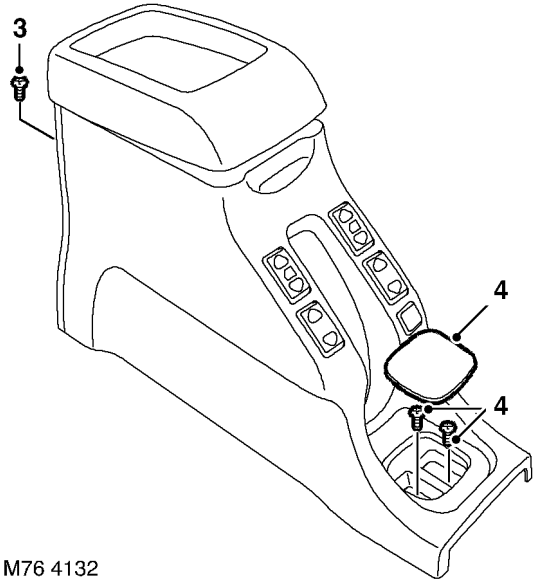

3. Remove 2 screws securing rear of console.
4. Remove screw cover and remove 2 screws securing front of console.

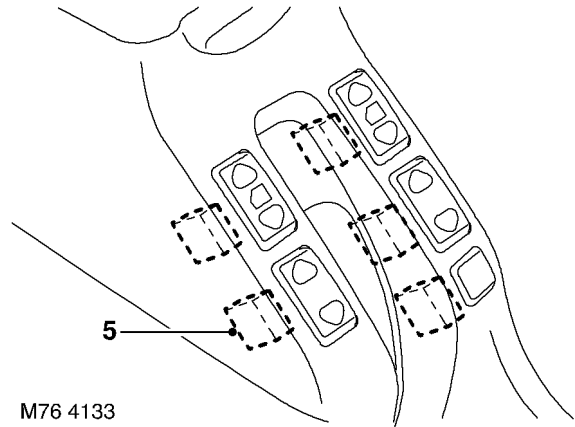

5. Disconnect multiplugs from window lift switches and if fitted, rear window isolator switch.



14. With assistance remove headlining through tail door.

NOTE: Do not carry out further dismantling if component is removed for access only.

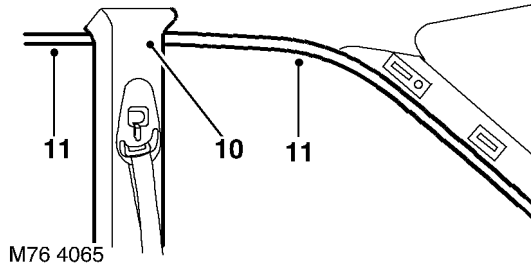

10. Release both 'B/C' post upper finishers and position aside.
 11. Release headlining from front and rear door aperture seals.

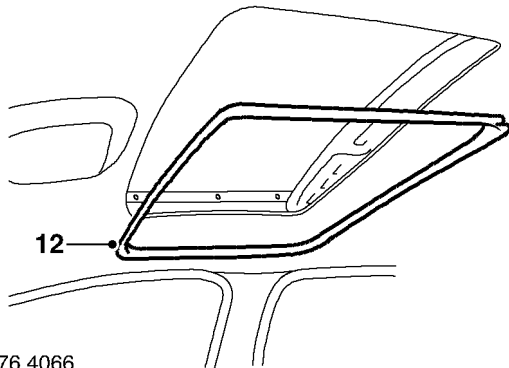

12. **Models with sun roof:** Release and remove sun roof surround finisher from sun roof aperture.

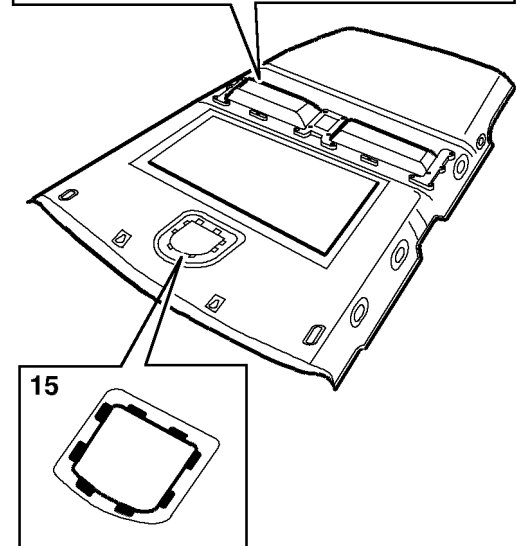
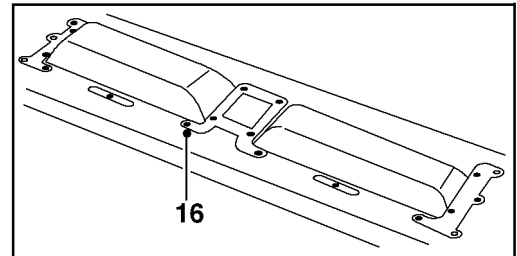

M76 4068

15. Release 8 tags securing front roof lamp support and remove support.
 16. Remove 14 nuts from stowage pockets, collect backing plates and remove stowage pockets.

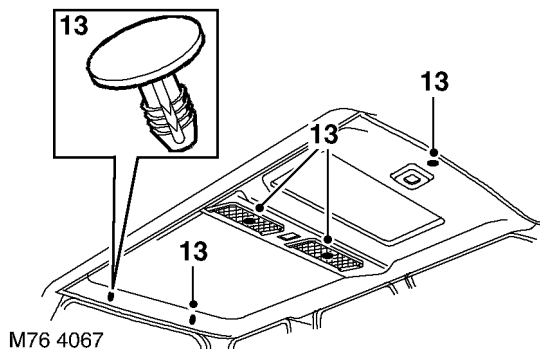

13. Remove 5 retaining studs from headlining.

SEATS

Refit

1. Position cushion cover to cushion pad and secure to frame with hog rings in position noted during removal.
2. Position seat belt and buckle to frame and tighten to 32 Nm.
3. Fit squab cover and pad to frame.
4. Fit front and sides of cushion cover to frame.
5. Fit rear of cushion cover to frame.
6. Fit cushion to squab and tighten Torx bolts to 28 Nm.
7. Fit end covers and tighten screws.
8. Position seat belt reel in seat squab and tighten nut to 32 Nm.
9. Fit seat belt reel cover and tighten screws.
10. Fit rear seat.

 **SEATS, REPAIRS, Rear seat - RH.**

Cover - rear seat cushion - LH

 **78.40.05**

Remove

1. Remove LH rear seat.

 **SEATS, REPAIRS, Rear seat - LH.**

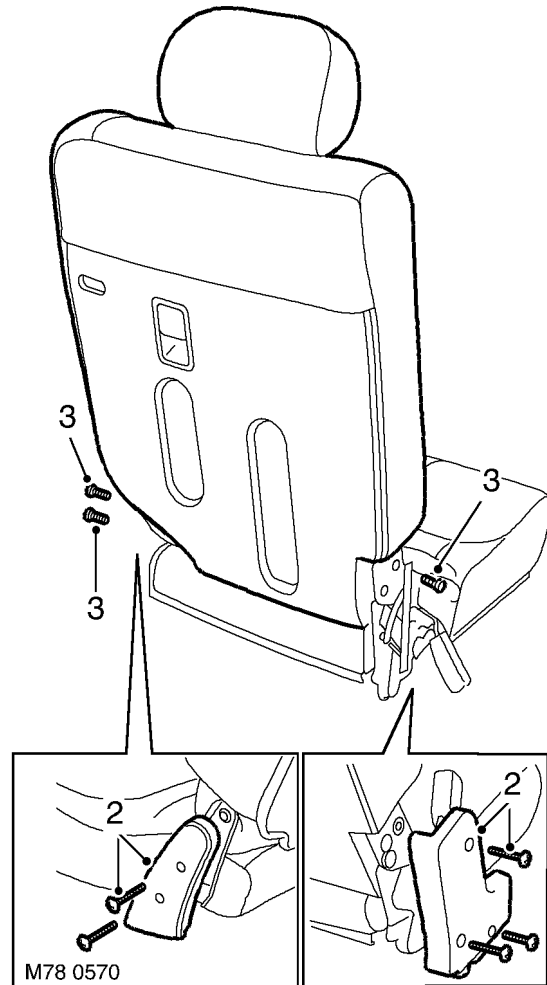

2. Remove 5 screws and remove both end covers.
3. Remove 3 Torx bolts and remove squab from cushion.

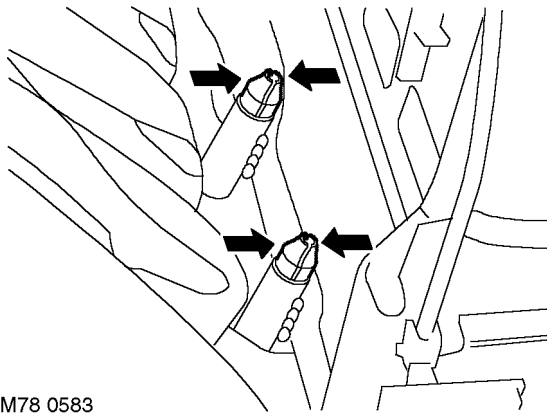

M78 0583

12. Release and remove 4 head restraint guide tubes.

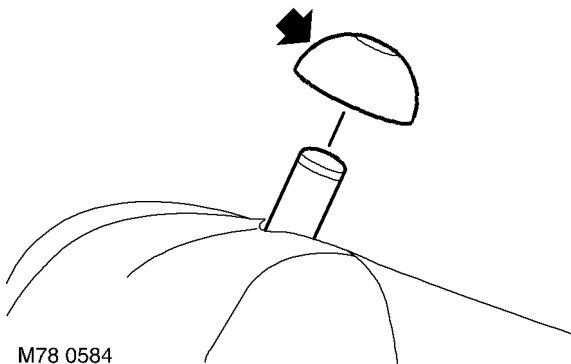

M78 0584

13. Release squab lock warning button escutcheon.

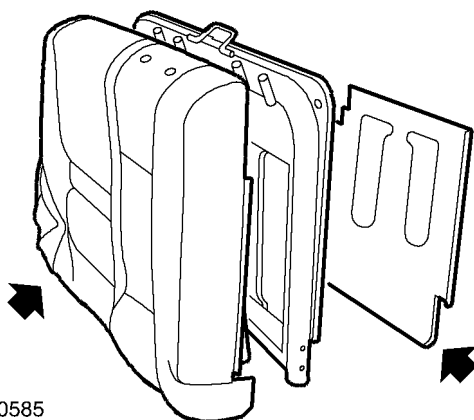

M78 0585

14. Remove squab cover and pad from frame.

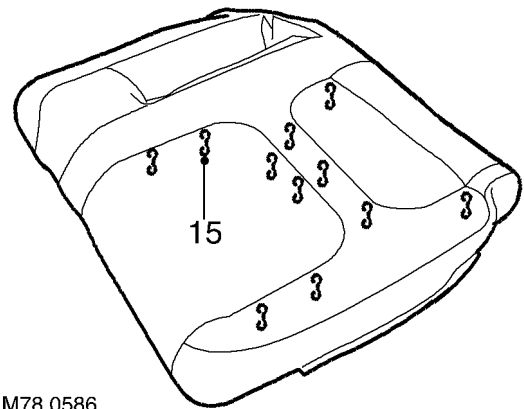

M78 0586

15. Remove and discard 12 hog rings and remove cover from pad.

Refit

1. Position squab cover to pad and secure hog rings.
2. Fit squab cover and pad to frame.
3. Fit head restraint guide tubes and seat lock warning button escutcheon.
4. Fit cover to sides and bottom of frame.
5. Fit cover to rear of frame and seat belt aperture.
6. Position latch escutcheon to back cloth and fit to frame. Ensure that the latch escutcheon is secured correctly into latch housing.
7. Fit cover to arm rest aperture.
8. Fit arm rest and tighten screws.
9. Fit arm rest aperture trim.
10. Fit head restraints.
11. Fit cushion to squab and tighten Torx bolts.
12. Fit side covers and tighten screws.
13. Position seat belt reel in seat squab and tighten nut to 32 Nm.
14. Fit seat belt reel cover and tighten screws.
15. Secure rear seat in locked position.

SUNROOF

Drain tube - sun/sliding roof - rear - each - 5 door

🔑 76.84.21

Remove

1. Remove headlining.
👉 **INTERIOR TRIM COMPONENTS, REPAIRS, Headlining - 5 door.**

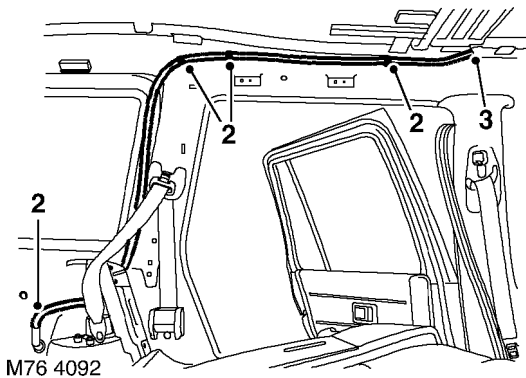

2. Release drain tube from wheel arch grommet and 3 securing clips.
3. Disconnect drain tube from sun roof and discard cable tie.
4. Remove drain tube.

Refit

1. Position drain tube.
2. Connect drain tube to sun roof and secure with new cable tie.
3. Connect drain tube to wheel arch grommet and secure in clips.
4. Secure wheel arch grommet.
5. Fit headlining.
👉 **INTERIOR TRIM COMPONENTS, REPAIRS, Headlining - 5 door.**

Finisher - flange to headlining - front

🔑 76.84.25

Remove

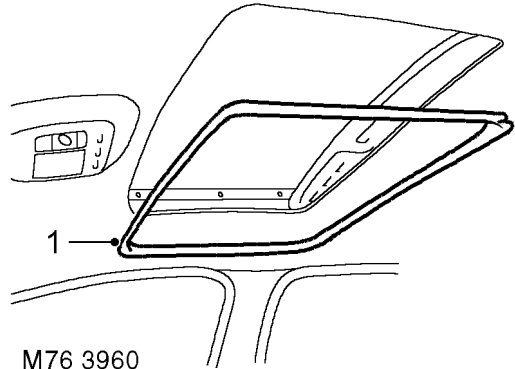

1. Release sun roof surround finisher from sun roof aperture and remove finisher.

Refit

1. Position sun roof surround finisher and secure in position, ensure locating lug is in position at the front of finisher.

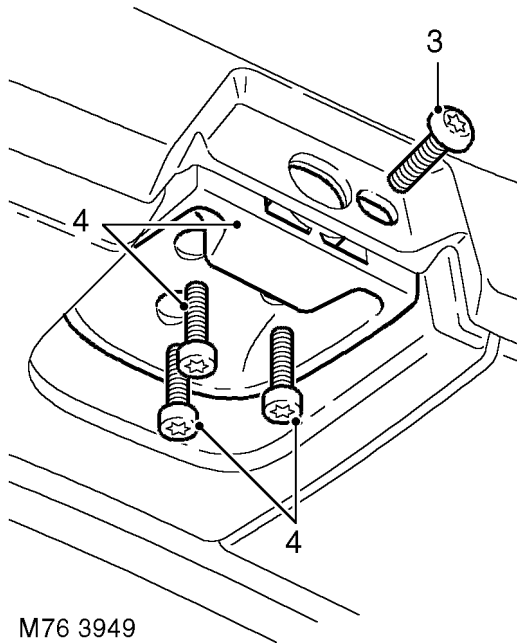

M76 3949

3. Remove Torx screw securing roof finisher to hard-back retainer.
4. Remove 3 Torx screws securing hard-back retainer and remove retainer.

Refit

1. Position hard-back retainer, fit Torx screws and tighten to 10Nm.
2. Fit Torx screw securing roof finisher.
3. Position catch, fit Torx screws and tighten to 10 Nm.
Ensure formed washer is correctly located in catch recess.
4. Fit hard-back.
HOOD, REPAIRS, Frame & hood cover - assembly - remove for access & refit.

Catch and retainer - hard-back - rear

76.61.95

Remove

1. Remove hard-back or soft-back.
HOOD, REPAIRS, Hard top - remove for access & refit.
HOOD, REPAIRS, Hard top - remove for access & refit.

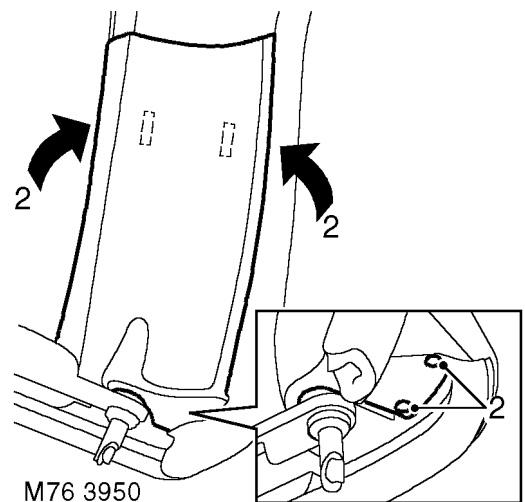

M76 3950

2. Remove 2 screws securing 'E' post finisher, release finisher from 2 clips and remove finisher.

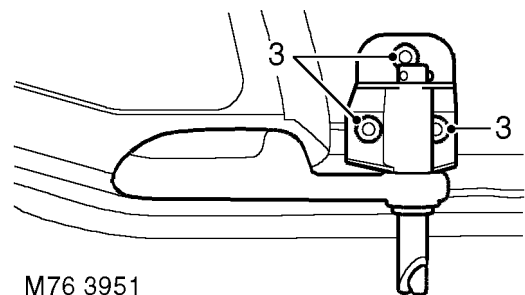

M76 3951

3. Remove 3 Torx screws securing catch and remove catch.
4. Remove lower rear quarter trim casing.
INTERIOR TRIM COMPONENTS, REPAIRS, Trim casing - rear quarter - lower - 3 door.

BODY DIMENSIONS

Item	From	To	Length
A	Outrigger panel, jig location hole 'LH'	Outrigger panel, jig location hole 'RH'	1070 (42.1250)
B	Sidemember, forward jig location hole 'LH'	Sidemember, forward jig location hole 'RH'	962 (37.874)
C	Front crossmember, jig location hole 'LH'	Front crossmember, jig location hole 'RH'	700 (27.559)
D	Sidemember, jig location hole 'LH'	Sidemember jig location hole 'RH'	892 (35.118)
E	Front subframe, front mounting hole 'LH'	Front subframe, front mounting hole 'RH'	772 (30.393)
F	Front subframe, rear outer mounting hole 'LH'	Front subframe, rear outer mounting hole 'RH'	859 (33.818)
G	Front subframe, rear inner mounting hole 'LH'	Front subframe, rear inner mounting hole 'RH'	660 (25.984)
H	Front subframe, front mounting hole	Front subframe, rear mounting hole	290 (11.417)
J	Outrigger panel, jig location hole	Front subframe, rear mounting hole	69 (2.716)
K	Front subframe, rear mounting hole	Tunnel front cross member, jig location hole	748 (29.448)
L	Spring location, hole	Front subframe, rear mounting hole	350.6 (13.803)
M	Sidemember, forward jig location	Front subframe, rear mounting hole	906 (35.669)
N	Front crossmember, jig location hole	Front subframe, rear mounting hole	985.5 (38.799)
P	Front subframe, rear mounting hole	Tunnel rear cross member, jig location	1051 (41.377)
R	Zero 'Z' datum	Spring location, inboard fixing hole	693.7 (27.311)
S	Zero 'Z' datum	Sidemember, jig location hole	388 (15.275)
T	Zero 'Z' datum	Sidemember, bottom jig location hole	312 (12.283)
U	Zero 'Z' datum	Front crossmember, jig location hole	154 (6.062))
V	Zero 'Z' datum	Front subframe, front mounting hole	125 (4.921)
W	Zero 'Z' datum	Front subframe, rear mounting hole	95.8 (3.771))



General

Body shells are of monocoque construction. Front and rear sections of the shell are designed as 'energy absorbing' zones. This means they are designed to deform progressively when subjected to impact in order to minimise the likelihood of injury to vehicle occupants.

It is essential that design dimensions and strength are restored in accident rectification. It is important that neither structural weakness nor excessive local stiffness are introduced into the vehicle during body repair.

Repairs usually involve a combination of operations ranging from straightening procedures to renewal of individual panels or panel assemblies. The repairer will determine the repair method and this decision will take into account a balance of economics between labour and material costs and the availability of repair facilities in both equipment and skills. It may also involve considerations of the vehicles' downtime, replacement vehicle availability and repair turn-around time.

It is expected that a repairer will select the best and most economic repair method possible, making use of the facilities available. The instructions given are intended to assist a skilled body repairer by expanding approved procedures for panel replacement. The objective is to restore the vehicle to a safe running condition by carrying out a repair which is as close as is feasible to original standard. The results should not advertise to the experienced eye that the vehicle has been damaged, although the repair might not be identical in all respects to the original factory build. Commercial bodyshop repair facilities cannot always duplicate methods of construction used during production.

Operations covered in this Manual do not include reference to testing the vehicle after repair. It is essential that work is inspected and suspension geometry checked after completion. Where necessary a road test of the vehicle should be carried out, particularly where safety-related items are concerned.

Where major units have been disconnected or removed it is necessary to ensure that fluid levels are checked and topped up where necessary. It is also necessary to ensure that the repaired vehicle is in a roadworthy condition in respect of tyre pressures, lights, washer fluid etc.

Body repairs often involve the removal of mechanical and electrical units and associated wiring. Where necessary, refer to the relevant section of the Workshop Manual for removal and refitting instructions.

Body components

Taking into consideration the differences in body styles, suspension systems and engine and transmission layouts, the location of the following components as applicable to a particular vehicle is critical:

- Front suspension upper damper mountings.
- Front suspension or sub frame mountings.
- Rear suspension upper damper mountings.
- Rear suspension mountings or lower pivots.

Additional points which can be used to check alignment and assembly are:

- Inner holes in crossmember - side - main floor.
- Holes in front longitudinals.
- Holes in side members.
- Holes in rear longitudinals.
- Holes in rear lower panels or extension rear floor.

Apertures for windscreen, backlight, bonnet and doors can be measured and checked using the dimensional information provided and also by offering up an undamaged component as a gauge.

Straightening

Whenever possible, structural members should be cold straightened under tension. Do not attempt to straighten with a single pull but rework the damaged area using a series of pulls, releasing tension between each stage and using the opportunity to check alignment.

PANEL REPAIRS

Roof assembly - 5 door

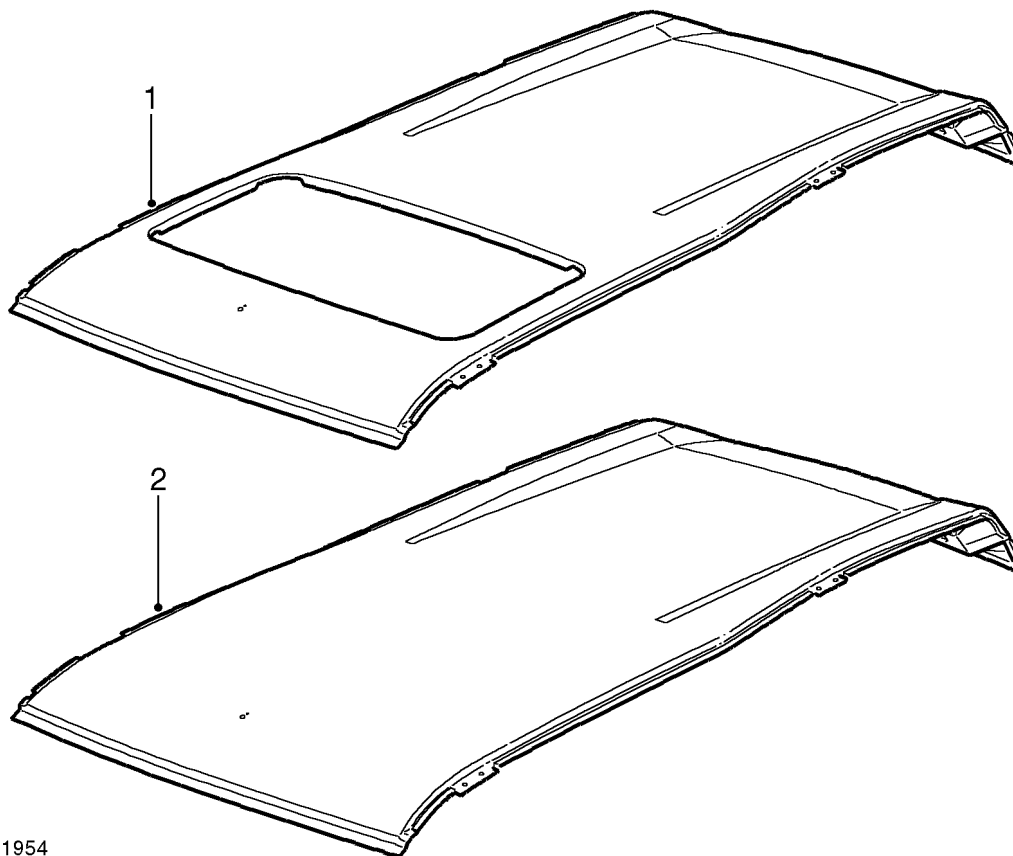

M77 1954

- 1 Roof assembly (with sunroof)
- 2 Roof assembly (without sunroof)

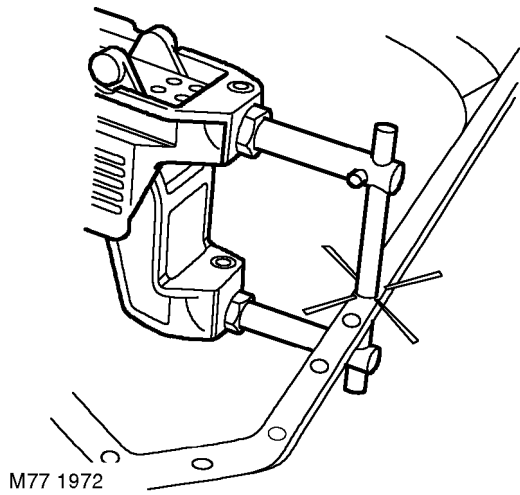

3. Use a resistance spot welder where access permits. Try to ensure weld quality by using a welding monitor where possible.

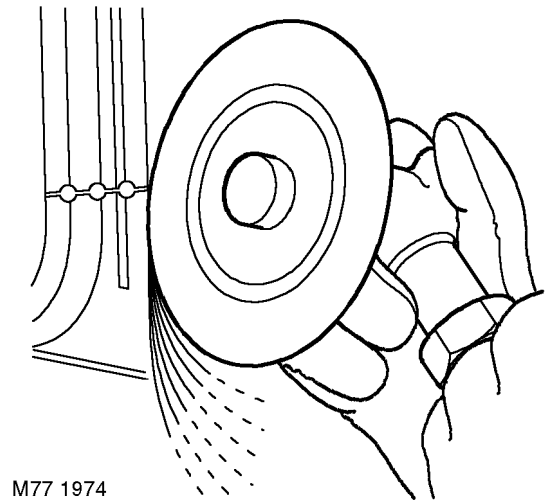

5. Dress MIG tack welds using a sander with 36 grit disc, or a belt-type sander where access is limited.

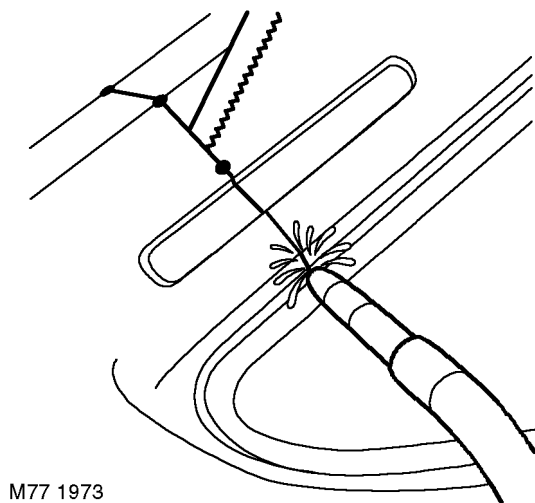



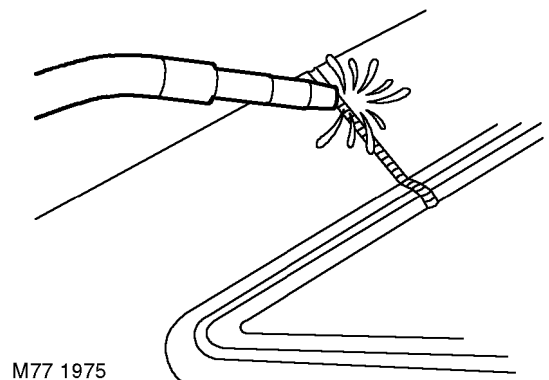













4. MIG tack weld butt joints and re-check alignment and panel contours where necessary. Ensure that a gap is maintained to minimise welding distortion, by inserting a hacksaw blade as an approximate guide.



6. MIG seam weld butt joints.

PANEL REPAIRS

Refit

1. Fit insulation pads to front and rear sides of engine bulkhead.
2. Position front carpet and fit treadplate to front door aperture.
3. Secure vehicle harness to valance.
4. **Driver's side:** Fit clutch pedal box.
5. Fit brake pedal box and brake servo.
6. Fit passenger compartment fuse box.
7. **LH side:** Fit LH front brake pipe. Bleed brake system.
 **BRAKES, ADJUSTMENTS, Brake bleed.**
8. **LH side:** On models with Diesel engines, fit fuel filter.
 **FUEL DELIVERY SYSTEM - DIESEL, REPAIRS, Filter - main.**
9. **LH side:** Fit LH engine mounting to body.
10. **LH side:** Fit engine compartment fuse box and related wiring.
11. **LH side:** Fit battery carrier. Do not connect battery earth lead.
 **CHARGING AND STARTING, REPAIRS, Carrier - battery.**
12. **LH side:** Fit engine compartment fusebox.
13. **LH side:** Fit ECM.
14. **LH side:** Fit air intake hose.
15. **LH side:** Fit air cleaner.
16. **LH side:** Fit front bumper LH support bracket.
17. **RH side:** Fit RH front brake pipe. Bleed brake system.
 **BRAKES, ADJUSTMENTS, Brake bleed.**
18. **RH side:** Fit PAS fluid reservoir.
19. **RH side:** Fit RH engine mounting to body.
20. **RH side:** Fit coolant expansion tank.
21. **RH side:** Fit windscreen washer reservoir.
 **WIPERS AND WASHERS, REPAIRS, Reservoir - washer.**
22. **RH side:** Fit front bumper RH support bracket.
23. Fit fascia.
 **INTERIOR TRIM COMPONENTS, REPAIRS, Fascia.**
24. Fit PAS rack.
 **STEERING, REPAIRS, Power steering rack.**
25. Fit front damper.
 **FRONT SUSPENSION, REPAIRS, Damper.**
26. Fit engine and gearbox.
 **ENGINE - K SERIES KV6, REPAIRS, Engine and automatic gearbox.**
27. Fit front suspension rear beam.
28. Fit front wing.
 **EXTERIOR FITTINGS, REPAIRS, Wing - front.**
29. Fit front wheel arch liner.
 **EXTERIOR FITTINGS, REPAIRS, Liner - front wheel arch.**
30. Fit engine bay shield.
31. Fit headlamp.
 **LIGHTING, REPAIRS, Headlamp assembly.**
32. Secure headlamp wiring. Fit PAS fluid cooler.
 **STEERING, REPAIRS, Oil cooler.**
33. Fit radiator.
 **COOLING SYSTEM - K SERIES KV6, REPAIRS, Radiator assembly.**
34. Fit front bumper armature.
35. Fit front bumper valance.
 **EXTERIOR FITTINGS, REPAIRS, Bumper - assembly - front.**
36. Fit underbelly panel.
 **EXTERIOR FITTINGS, REPAIRS, Panel - underbelly.**
37. Fit road wheel(s) and tighten nuts to 115 Nm.
38. Connect all ECUs.
39. Connect battery earth lead.



Refit

1. Secure vehicle harness to inner sill.
2. Fit headlining.
 INTERIOR TRIM COMPONENTS, REPAIRS, Headlining - 3 door.
3. Fit rear roof panel finisher.
4. Fit seal and rear quarter vent.
 EXTERIOR FITTINGS, REPAIRS, Body quarter vent assembly - 3 door.
5. Secure carpet to inner sill.
6. Fit side door aperture seal.
7. Fit treadplate from side door aperture.
8. Fit rear body side casing.
 INTERIOR TRIM COMPONENTS, REPAIRS, Trim casing - body side - rear - LH.
9. Fit rear seat.
 SEATS, REPAIRS, Rear seat - LH.
 SEATS, REPAIRS, Rear seat - RH.
10. Fit front door striker to 'B/C' post.
11. Fit front seat belt.
 RESTRAINT SYSTEMS, REPAIRS, Automatic belt assembly - front - 3 door.
12. Fit rear wheel arch liner.
13. Fit rear wheel arch extension.
 EXTERIOR FITTINGS, REPAIRS, Wheelarch extension - rear wing part.
14. Fit road wheel(s) and tighten nuts to 115 Nm.
15. Connect all ECUs.
16. Connect alternator.
17. Connect battery earth lead.

'B/C' post reinforcement - 5 door

In this procedure, the rear outer body side panel and the inner panel are replaced in conjunction with the 'B/C' post reinforcement.

Remove

1. Disconnect battery earth lead.
2. Disconnect alternator.
3. Disconnect all ECUs.
4. Remove rear door.
 DOORS, REPAIRS, Door assembly - rear - remove for access & refit.
5. Remove headlining.
 INTERIOR TRIM COMPONENTS, REPAIRS, Headlining - 5 door.
6. Remove front seat belt.
 RESTRAINT SYSTEMS, REPAIRS, Automatic belt assembly - front - 5 door.
7. Remove 'B/C' post lower finisher.
 INTERIOR TRIM COMPONENTS, REPAIRS, Trim finisher - 'B' post - lower - 5 door.
8. Remove front door striker from 'B/C' post.
9. Remove front seat.
 SEATS, REPAIRS, Front seat.
10. Remove rear seat.
 SEATS, REPAIRS, Rear seat - LH.
 SEATS, REPAIRS, Rear seat - RH.
11. Remove treadplate from side door aperture(s).
12. Remove side door aperture seal(s).
13. Release carpet from inner sill and position aside.
14. Release vehicle harness from inner sill and position aside.

PANEL REPAIRS

Repair

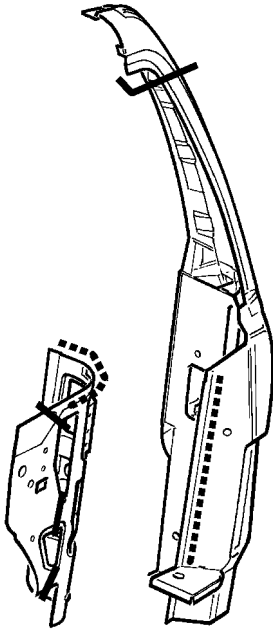



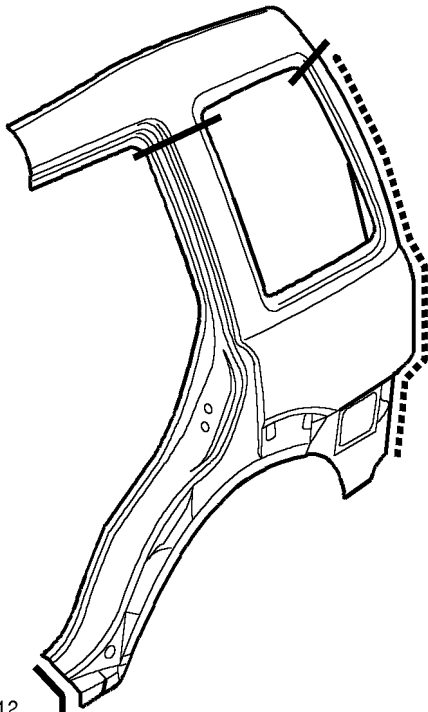







M77 2017



M77 2012

1. Remove existing panel(s), prepare panel joint faces and install new panel(s) in accordance with Panel Replacement Procedure. Punch or drill holes in new panel for plug welding as shown.

Refit

1. **LH side:** Fit tail door striker.
2. **RH side:** Fit fuel tank.
 **FUEL DELIVERY SYSTEM - PETROL, REPAIRS, Tank.**
3. **RH side:** Fit fuel filler neck.
 **FUEL DELIVERY SYSTEM - PETROL, REPAIRS, Filler neck.**
4. **RH side:** Fit tail door.
 **DOORS, REPAIRS, Door - tail assembly - remove for access & refit.**
5. Secure vehicle harness to 'E' post.
6. Fit rear body side glass.
 **SCREENS, REPAIRS, Glass - body side - rear.**
7. Fit loadspace carpet.
 **INTERIOR TRIM COMPONENTS, REPAIRS, Carpet - luggage compartment.**
8. Fit rear quarter upper casing.
 **INTERIOR TRIM COMPONENTS, REPAIRS, Trim casing - rear quarter - upper - 5 door.**
9. Fit rear quarter lower casing.
 **INTERIOR TRIM COMPONENTS, REPAIRS, Trim casing - rear quarter - lower - 5 door.**
10. Fit tail door aperture seal.
11. Fit tail door glass side finisher.
 **DOORS, REPAIRS, Finisher - rear screen - side - 5 door.**
12. Fit tail door glass upper finisher.
13. Fit roof panel finisher.
 **DOORS, REPAIRS, Finisher - rear screen - side - 5 door.**
14. Fit tail lamp.
 **LIGHTING, REPAIRS, Lamp assembly - tail.**
15. Fit rear wheel arch liner.
16. Fit rear bumper valance.
 **EXTERIOR FITTINGS, REPAIRS, Bumper valance - rear.**
17. Fit road wheel(s) and tighten nuts to 115 Nm.
18. Connect all ECUs.
19. Connect alternator.
20. Connect battery earth lead.



The following panel combination times show the total time to remove/refit body panels, MET items and any paint processes. Times for 3 door front end combination panel replacement will be the same as 5 door.

3 Door - Bodyside combination panel times

Panel description	Total time
Front door Wing	12.2
Front door Rear outer bodyside panel	27.2 LH 29.7 RH
Front door Bodyside assembly	34.6 LH 36.4 RH
Front door Bodyside assembly Wing	37.7 LH 40.2 RH
Front door Front outer bodyside panel A-post reinforcement Windscreen Wing Valance outer reinforcement rear section	33.8 LH 35.1 RH

CORROSION PREVENTION AND SEALING

Key to Figure, cavity wax treatment areas and injection holes - 3 door

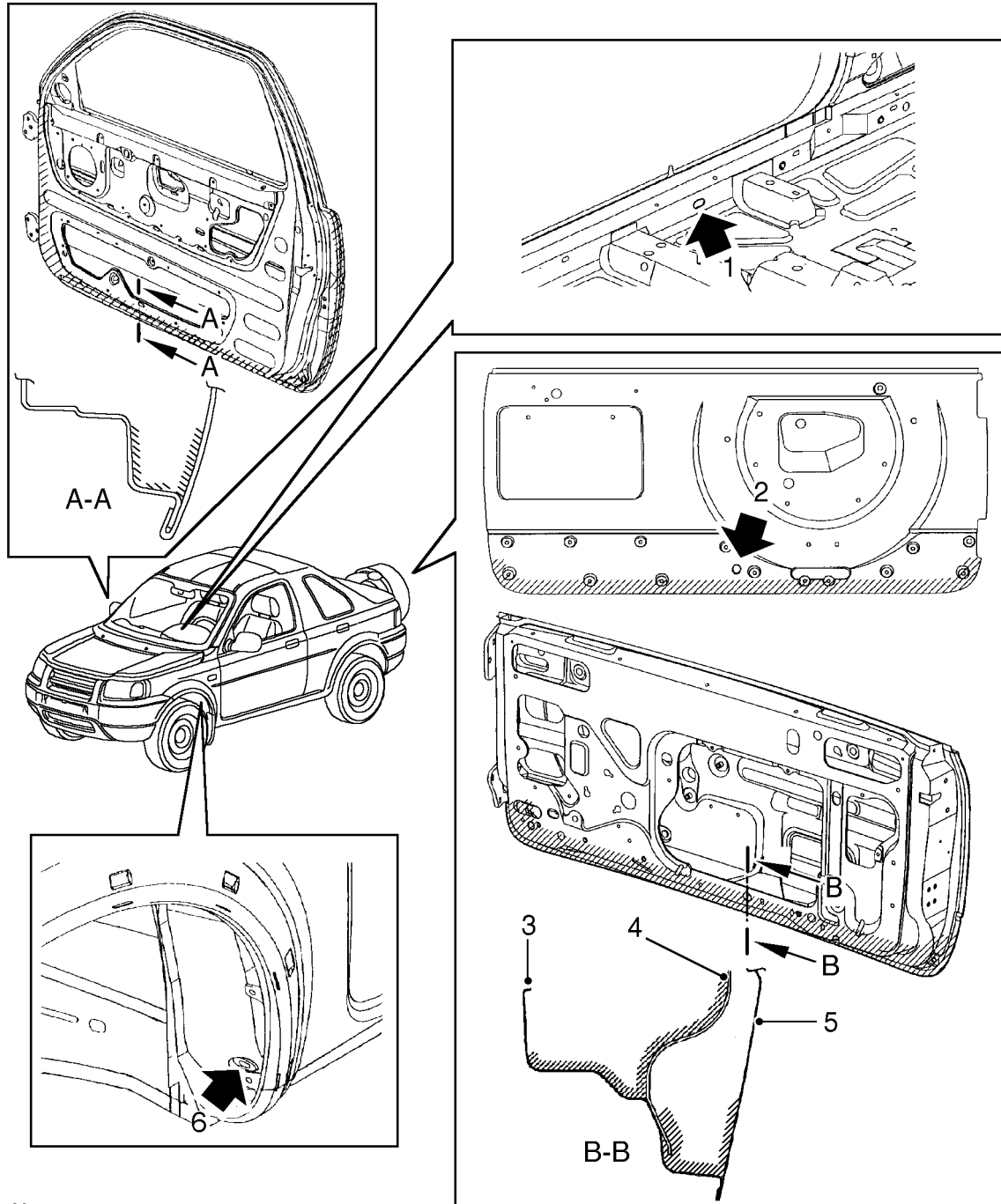

M77 1923

- 1 Injection hole for inner sill
- 2 Injection hole for area between tail door outer panel and reinforcing panel
- 3 Tail door inner panel
- 4 Tail door reinforcing panel
- 5 Tail door outer panel
- 6 Injection hole for sill



Adhesive on 'A' post, sill and rear quarter - 5 door

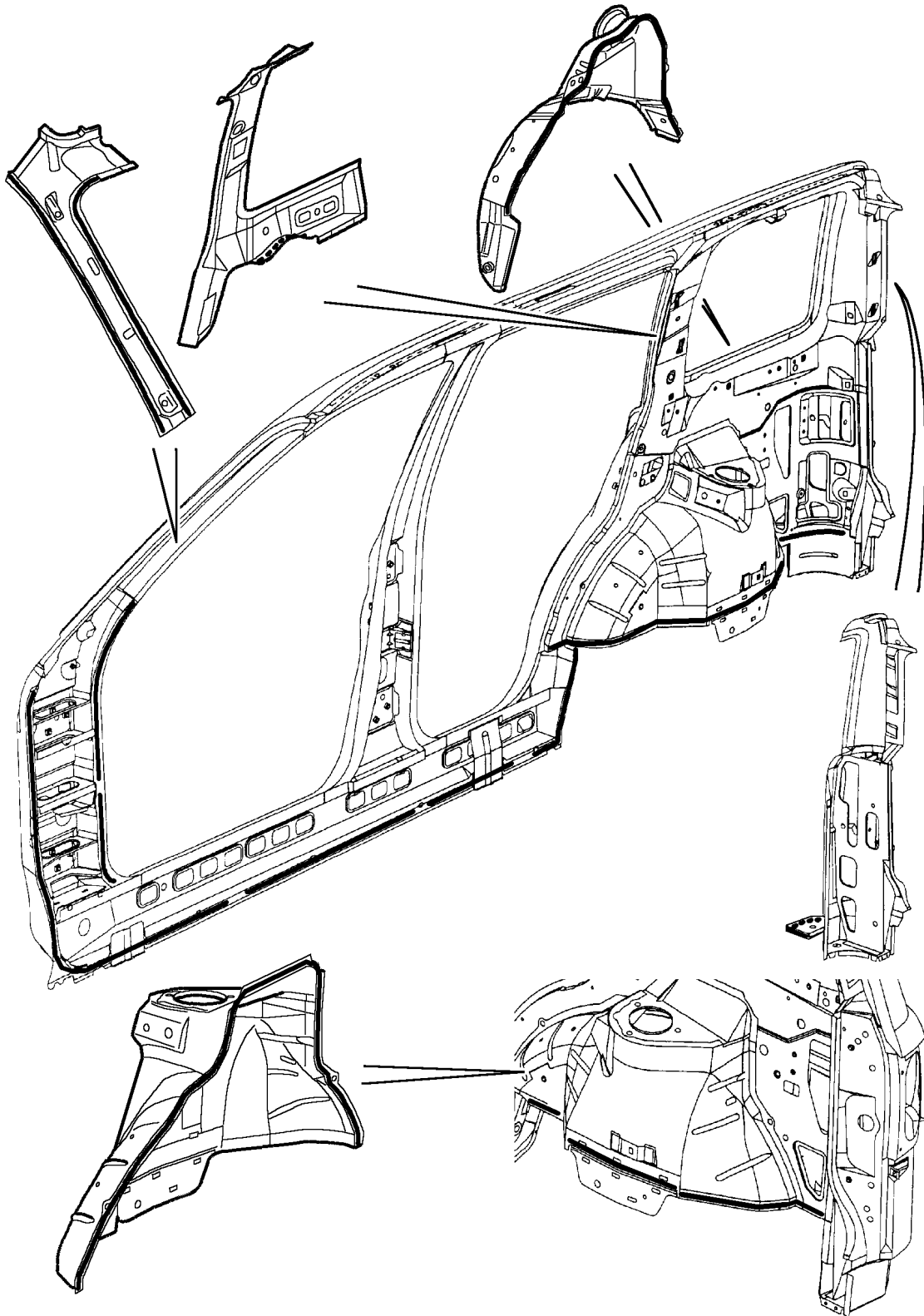

M77 1929

Joints symmetrically opposite to those shown are also treated. Apply 3 mm diameter beads to all joints shown. Leave sill drain points free of adhesive.

CORROSION PREVENTION AND SEALING

Sealed seams in front wheelarch, engine compartment and screen rail

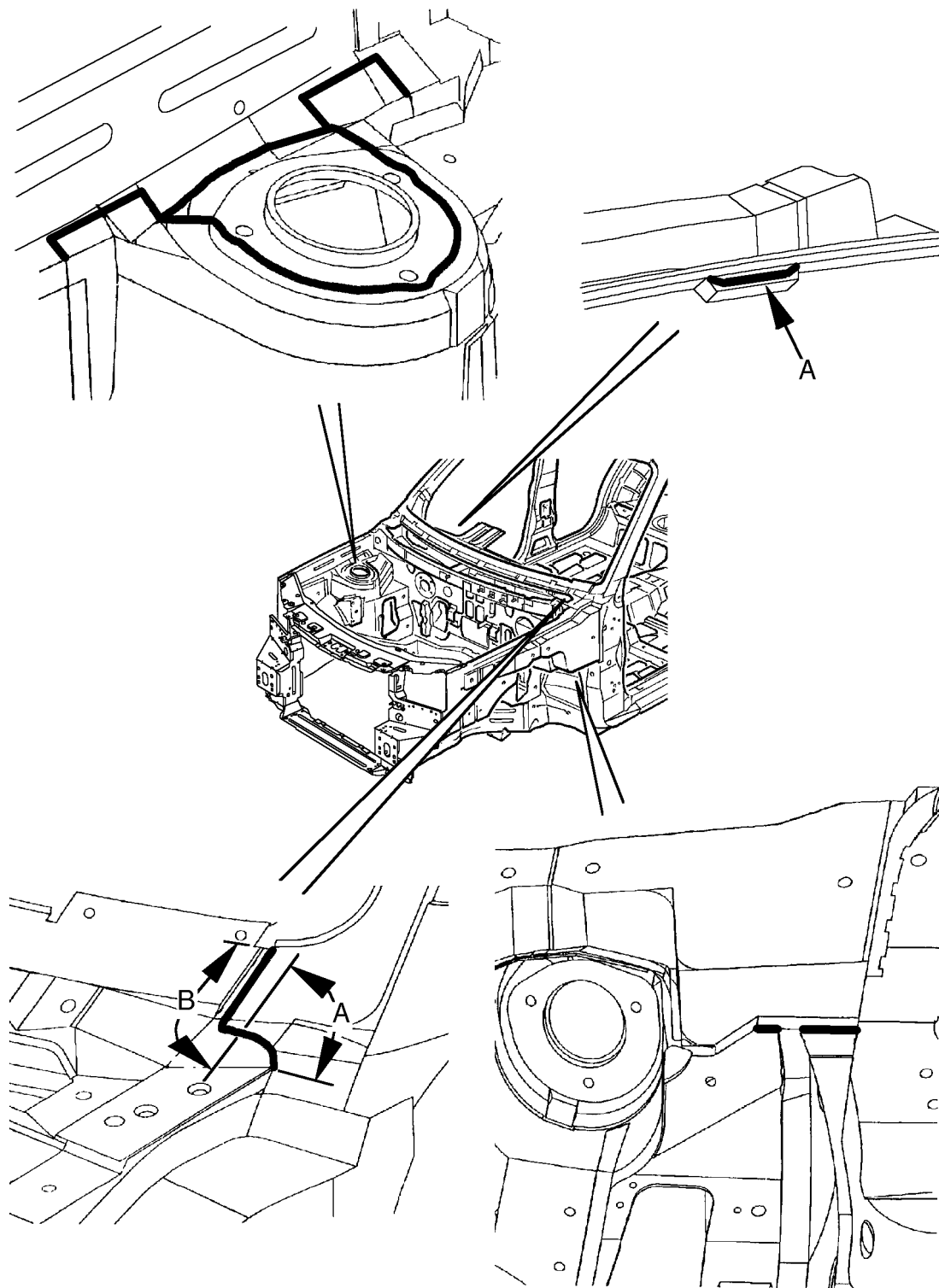

M77 2051



Panel Preparation

General

Replacement panels are supplied with a cathodic primer coating as part of the panel protection and in compliance with the vehicle's Corrosion Warranty, where applicable. **DO NOT remove the primer before paint refinishing. In the event of localized surface damage or imperfections, ensure that only the minimum of primer is removed during rectification work for effective repair.**

Rectify damage as far as possible by panel beating or straightening. To remove corrosion or paint runs on outer surfaces, abrade the primer coat in the affected area as necessary using the following procedure:

- 1 Clean the panel using a solvent wipe.
- 2 Treat exposed areas of metal with an etch phosphate process.
- 3 Re-treat the affected area using either a separate acid-etch primer and two-pack surfacer, or an integrated etch primer/filler.

Panel Preparation

The following procedures should be applied when repairing panels.

Welded panels

- 1 Remove primer from the immediate vicinity of new and existing panel flanges, cleaning to bright metal finish.
- 2 On joints to be spot welded, apply weld-through zinc rich primer to joint faces of both flanges. Make spot welds while primer is still wet or according to the manufacturer's instructions.
- 3 Dress accessible weld joints.
- 4 Clean panel using solvent wipe.
- 5 Treat bare metal with an etch phosphate process.
- 6 Re-treat repaired areas.

Sectioned panels

When replacing part or sectioned panels, the basic procedure is the same as for welded panels described above, with the following variations:

- 1 Remove primer from both new and existing joint faces, cleaning to a bright metal finish.
- 2 Where an overlap joint with the existing panel is to be spot welded, apply weld-through, zinc rich primer to both joint faces and spot weld while the primer is still wet, or according to the manufacturer's instructions.
- 3 MIG weld butt joints where applicable.
- 4 Clean the panel with a solvent wipe.
- 5 Treat bare metal areas using an etch phosphate process.
- 6 Re-prime affected areas as necessary as for rectifying transit damage.
- 7 Treat the inner faces of lap or butt joints with a suitable cavity wax.

Clinched panels

- 1 Abrade primer on new and existing panel joint faces, and clean using a solvent wipe.
- 2 Apply metal-to-metal adhesive where applicable.
- 3 Where joints are to be spot welded, apply suitable weld-through, zinc rich primer to weld areas.
- 4 Where joints are to be MIG, arc or gas welded, apply zinc rich primer in adjacent areas **but leave the welded area untreated.**
- 5 To retain the panel while clinching the flanges, tack spot weld or plug weld as appropriate.
- 6 Clean the panel with a solvent wipe.
- 7 Treat bare metal areas with a suitable etch phosphate process.
- 8 Re-prime affected areas as necessary as for rectifying transit damage.

HEATING AND VENTILATION

Resistor unit - fan motor

🔑 80.20.17

Remove

1. **LHD models only:** Disconnect air inlet connector hose from heater and evaporator.

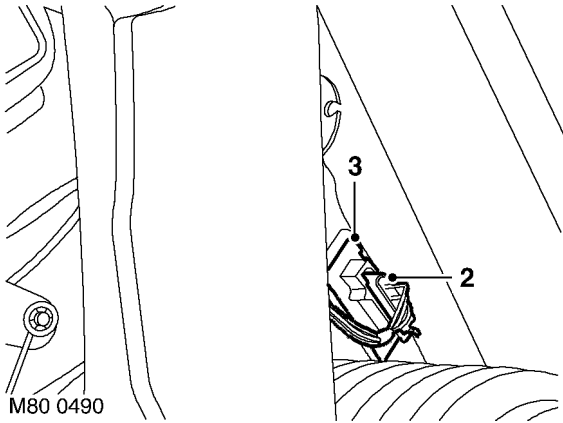

2. Disconnect multiplug from resistor.
3. Release clip and remove resistor from heater.

Refit

1. Fit resistor to heater.
2. Connect multiplug to resistor.
3. **LHD models only:** Connect air inlet connector hose.

Matrix - heater

🔑 80.20.29

Remove

1. Remove heater assembly.
👉 **HEATING AND VENTILATION, REPAIRS, Heater unit.**

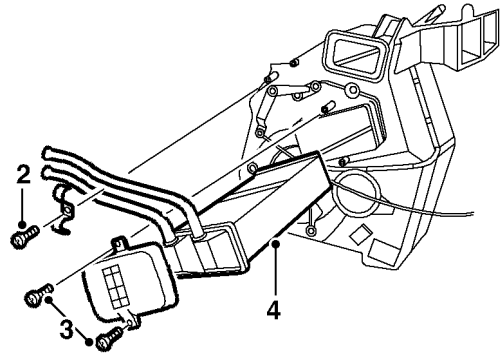

2. Remove screw securing pipe clamp to heater casing and remove clamp.
3. Remove 2 screws from matrix cover and remove cover.
4. Remove heater matrix.

Refit

1. Fit heater matrix to heater assembly.
2. Fit matrix cover and secure with screws.
3. Fit pipe clamp and secure with screw.
4. Fit heater assembly.
👉 **HEATING AND VENTILATION, REPAIRS, Heater unit.**

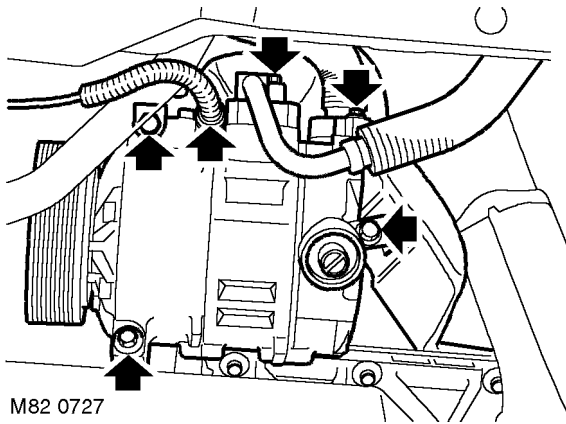

7. Remove 2 bolts securing high and low pressure pipes to compressor. Release pipes from compressor, remove and discard 'O' rings.

CAUTION: Before disconnecting or removing components, ensure the immediate area around joint faces and connections are clean. Plug open connections to prevent contamination.

8. Disconnect multiplug from compressor.
9. Note fitted position of heat shield on compressor and remove 3 bolts securing compressor to front mounting plate and cylinder block. Remove compressor and heat shield.

Refit

1. If a new compressor is being installed, drain the required amount of refrigerant oil from the new compressor.
 - GENERAL INFORMATION, Air conditioning compressor replacement.**
2. A new compressor is sealed and pressurised with Nitrogen gas, slowly release the sealing cap, gas pressure should be heard to release as the seal is broken.
3. Clean compressor and mating face on front mounting plate and cylinder block.
4. Position compressor, fit but do not fully tighten lower bolt.
5. Position heat shield and fit compressor upper securing bolts. Tighten compressor upper and lower securing bolts to 25 Nm.
6. Remove caps from compressor and high pressure pipe.
7. Clean compressor high pressure pipe connection.
8. Lubricate new 'O' ring with refrigerant oil and fit to high pressure pipe.
9. Connect high pressure pipe to compressor, fit and tighten bolt to 25 Nm.
10. Connect multiplug to compressor.

11. Remove caps from compressor and low pressure pipe.
12. Clean compressor low pressure pipe connection.
13. Lubricate new 'O' ring with refrigerant oil and fit to low pressure pipe.
14. Connect low pressure pipe to compressor, fit and tighten bolt to 25 Nm.
15. Clean pulley 'V's and tensioner pulley running surface.
16. Using a 3/8" square drive socket bar, raise ancillary drive belt tensioner and fit drive belt to pulleys.
17. Fit splash shield and secure with bolts.
18. Fit RH road wheel and tighten nuts to 115 Nm.
19. Replace receiver drier.
 - AIR CONDITIONING, REPAIRS, Receiver drier.**
20. Recharge A/C system.
 - AIR CONDITIONING, REFRIGERANT RECOVERY, RECYCLING AND RECHARGING, Refrigerant recovery - recycling and recharge.**
21. Connect battery earth lead.
22. Fit underbelly panel.
 - EXTERIOR FITTINGS, REPAIRS, Panel - underbelly.**

WIPERS AND WASHERS

Motor & linkage - wiper

🔑 84.15.11

Remove

1. Remove air intake moulding.
👉 **HEATING AND VENTILATION, REPAIRS, Plenum - air intake.**

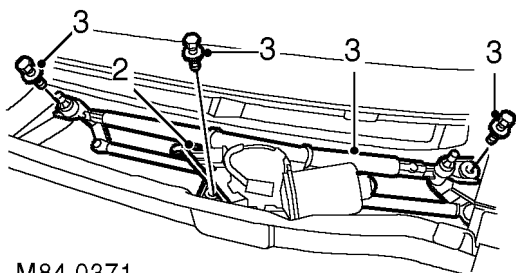

M84 0371

2. Disconnect multiplug from windscreen wiper motor.
3. Remove 3 bolts securing wiper motor and linkage to body and remove wiper motor and linkage.

Refit

1. Fit motor and linkage to body, fit bolts and tighten to 5 Nm.
2. Connect multiplug to windscreen wiper motor.
3. Fit air intake moulding.
👉 **HEATING AND VENTILATION, REPAIRS, Plenum - air intake.**

Switch - wiper/washer

🔑 84.15.34

Remove

1. Remove rotary coupler.
👉 **RESTRAINT SYSTEMS, REPAIRS, Rotary coupler - (SRS) air bag system.**

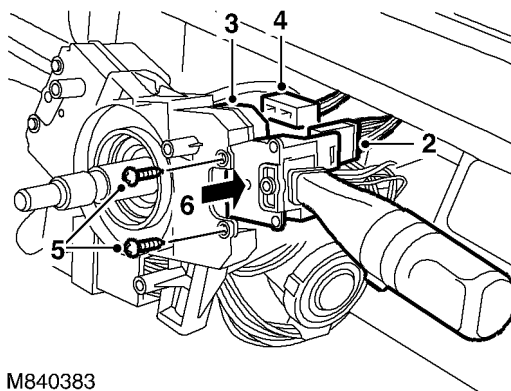



M840383

2. Disconnect multiplug from washer and wiper switch.
3. Release multiplug connector from switch base on steering column.
4. Disconnect multiplug from connector.
5. Remove 2 screws from wiper switch.
6. Depress retaining tag and remove switch.

Refit

1. Fit washer and wiper switch assembly and secure with screws.
2. Connect multiplugs to switch.
3. Secure multiplug to steering column.
4. Fit rotary coupler.
👉 **RESTRAINT SYSTEMS, REPAIRS, Rotary coupler - (SRS) air bag system.**

**Refit**

1. Ensure pulleys are clean and damage free.
CAUTION: Examine drive belt for signs of wear. A drive belt with cracked ribs is acceptable. A drive belt that has loose or missing parts of ribs must be changed.
2. Use **12-163** to hold belt tensioner off and with assistance, fit ancillary belt. Ensure belt is correctly located in pulley grooves.
3. Fit splash shield and tighten bolts to 10 Nm.
4. Fit underbelly panel.
 **EXTERIOR FITTINGS, REPAIRS, Panel - underbelly.**
5. Fit acoustic cover.
 **ENGINE - Td4, REPAIRS, Cover - engine acoustic.**
6. Connect battery earth lead.

Ancillary drive belt - K1.8 without A/C

 **86.10.03**

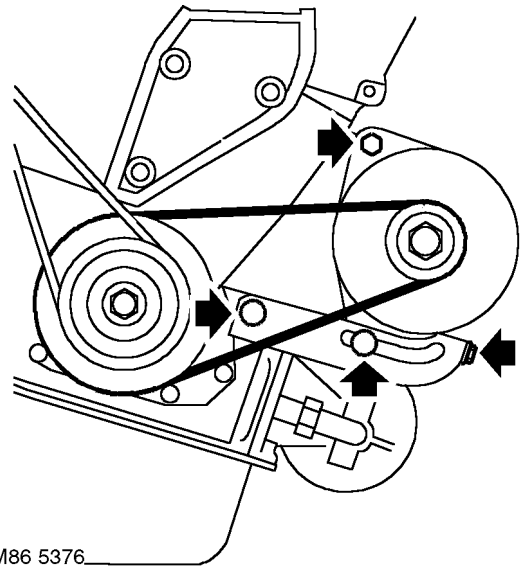

Remove

1. Disconnect battery earth lead.
2. Remove PAS pump drive belt.
 **STEERING, REPAIRS, Drive belt - K1.8.**



3. Loosen alternator pivot nut and bolt.
4. Loosen bolt securing alternator adjustment bracket to engine.
5. Loosen bolt securing alternator to adjustment bracket.
6. Rotate alternator drive belt adjustment bolt anti-clockwise to release tension from belt and remove belt.

Refit

1. Ensure pulleys are clean and damage free.
CAUTION: Examine drive belt for signs of wear. A drive belt with cracked ribs is acceptable. A drive belt that has loose or missing parts of ribs must be changed.
2. Fit drive belt. Ensure belt is located correctly in pulley grooves.
3. Adjust belt tension.
 **CHARGING AND STARTING, ADJUSTMENTS, Ancillary drive belt - K1.8.**
4. Fit PAS pump drive belt.
 **STEERING, REPAIRS, Drive belt - K1.8.**
5. Connect battery earth lead.

CLICK HERE TO **DOWNLOAD** THE COMPLETE MANUAL

- Thank you very much for reading the preview of the manual.
- You can download the complete manual from: www.heydownloads.com by clicking the link below



- Please note: If there is no response to CLICKING the link, please download this PDF first and then click on it.

CLICK HERE TO **DOWNLOAD** THE COMPLETE MANUAL