



**Workshop Manual**

*Service Procedures*

**Werkplaatshandboek**

*Onderhoudsprocedures*

**Manual d'Atelier**

*Procédures de service*

**Werkstatthandbuch**

*Wartungsanleitungen*

**Manuale d'Officina**

*Procedure di servizio*

**Manual de Taller**

*Procedimientos de servicio*

**Manual de Oficina**

*Processos de Serviço*



CLICK HERE TO **DOWNLOAD** THE COMPLETE MANUAL

- Thank you very much for reading the preview of the manual.
- You can download the complete manual from: [www.heydownloads.com](http://www.heydownloads.com) by clicking the link below



- Please note: If there is no response to CLICKING the link, please download this PDF first and then click on it.

CLICK HERE TO **DOWNLOAD** THE COMPLETE MANUAL

# CONTENTS

## **ENGINE MANAGEMENT SYSTEM - SIEMENS ..... 18-3-1**

### **REPAIRS**

Spark plugs .....	18-3-1
Coil - each - LH bank .....	18-3-2
Coil - each - RH bank.....	18-3-2
Engine control module (ECM) - Non NAS .....	18-3-3
Engine control module (ECM) - fuel - NAS .....	18-3-4
Idle Air Control Valve (IACV) .....	18-3-5
Sensor - intake air temperature (IAT) - NAS .....	18-3-6
Sensor - engine coolant temperature (ECT) .....	18-3-6
Sensor - crankshaft position (CKP) .....	18-3-7
Sensor - throttle position (TP).....	18-3-8
Sensor - thermostat monitoring (TM) - KV6 - NAS .....	18-3-9
Sensor - camshaft position (CMP) .....	18-3-10
Sensor - knock (KS) .....	18-3-11
Sensor - throttle pedal position - Non NAS .....	18-3-11
Sensor - combined - manifold absolute pressure/Intake air temperature (MAP/IAT).....	18-3-12

## **FUEL DELIVERY SYSTEM - DIESEL ..... 19-1-1**

### **ADJUSTMENTS**

Fuel tank - drain.....	19-1-1
------------------------	--------

### **REPAIRS**

Element - air cleaner .....	19-1-3
Switch - fuel temperature .....	19-1-3
Switch - inertia - fuel cut off .....	19-1-4
Sensor - fuel pressure .....	19-1-4
Relay - fuel pump.....	19-1-5
Filter - main .....	19-1-5
Matrix cooler - fuel .....	19-1-6
Pump - injection .....	19-1-7
Turbocharger .....	19-1-10
Intercooler .....	19-1-13
Solenoid valve - boost control .....	19-1-14
Sensor - turbo charger boost pressure .....	19-1-15
Ducting - intake assembly .....	19-1-16
Pump - integral - fuel tank - rear .....	19-1-17
Regulator - fuel pressure .....	19-1-18
Lift pump - fuel .....	19-1-19
Tank .....	19-1-20
Filler neck .....	19-1-22
Injector .....	19-1-23
Injector pipe .....	19-1-25
Glow plug .....	19-1-26
Electronic control unit (ECU) - glow plugs.....	19-1-27
Switch - cruise control.....	19-1-27

# CONTENTS

## EXTERIOR FITTINGS ..... 76-2-1

### REPAIRS

Wing - front .....	76-2-1
Liner - front wheel arch .....	76-2-2
Liner - rear wheel arch .....	76-2-3
Panel - underbelly .....	76-2-4
Mirror - exterior - electric .....	76-2-4
Mud flap - front .....	76-2-5
Mud flap - rear .....	76-2-5
Bracket - spare wheel mounting .....	76-2-6
Side rail - integral roof rack - 5 door .....	76-2-7
Bonnet .....	76-2-7
Cable/rod - bonnet lock control .....	76-2-8
Bumper - assembly - front .....	76-2-9
Bumper valance - rear .....	76-2-10
Finisher - sill - lower .....	76-2-11
Moulding - roof - 5 door .....	76-2-12
Wheelarch extension - rear wing part .....	76-2-13
Body quarter vent assembly - 3 door .....	76-2-14

## INTERIOR TRIM COMPONENTS ..... 76-3-1

### REPAIRS

Sun visor .....	76-3-1
Trim casing - rear quarter - lower - 3 door .....	76-3-1
Trim casing - rear quarter - lower - 5 door .....	76-3-2
Trim casing - rear quarter - upper - 3 door .....	76-3-3
Trim casing - rear quarter - upper - 5 door .....	76-3-4
Trim finisher - 'A' post - upper - renew .....	76-3-5
Trim finisher - 'B/C' post - upper - renew .....	76-3-5
Trim finisher - 'B' post - lower - 5 door .....	76-3-6
Trim casing - body side - rear - LH .....	76-3-7
Console - front .....	76-3-8
Console - rear .....	76-3-10
Fascia .....	76-3-11
Cup holder assembly - fascia .....	76-3-16
Stowage box - fascia .....	76-3-17
Carpet - luggage compartment .....	76-3-17
Glove box .....	76-3-18
Headlining - 3 door .....	76-3-19
Headlining - 5 door .....	76-3-20

## SCREENS ..... 76-4-1

### REPAIRS

Windscreen .....	76-4-1
Glass - body side - rear .....	76-4-3



---

## Specifications

---

Land Rover are constantly seeking to improve the specification, design and production of their vehicles and alterations take place accordingly. Whilst every effort has been made to ensure the accuracy of this Manual, it should not be regarded as an infallible guide to current specifications of any particular vehicle.

This Manual does not constitute an offer for sale of any particular vehicle. Land Rover Dealers are not agents of Land Rover and have no authority to bind the manufacturer by any expressed or implied undertaking or representation.

# GENERAL INFORMATION

---

## Ball and roller bearings

---

### General

When removing and installing bearings, ensure that the following practices are observed to ensure component serviceability:

- Remove all traces of lubricant from the bearing under inspection by cleaning with a suitable degreasant; maintain absolute cleanliness throughout operations.
- Conduct a visual inspection for markings on rolling elements, raceways, outer surface of outer rings or inner surface of inner rings. Reject any bearings found to be marked, since marking in these areas indicates onset of wear.
- Hold inner race of bearing between finger and thumb of one hand and spin outer race to check that it revolves absolutely smoothly. Repeat, holding outer race and spinning inner race.
- Rotate outer ring gently with a reciprocating motion, while holding inner ring; feel for any check or obstruction to rotation. Reject bearing if action is not perfectly smooth.
- Lubricate bearing with generous amounts of lubricant appropriate to installation.
- Inspect shaft and bearing housing for discoloration or other markings which indicate movement between bearing and seatings.
- Ensure that shaft and housing are clean and free from burrs before fitting bearing.
- If one bearing of a pair shows an imperfection, it is advisable to replace both with new bearings; an exception could be if the faulty bearing had covered a low mileage, and it can be established that damage is confined to only one bearing.
- Never refit a ball or roller bearing without first ensuring that it is in a fully serviceable condition.
- When hub bearings are removed or displaced, NEW bearings must be fitted; do not attempt to refit the old hub bearings.

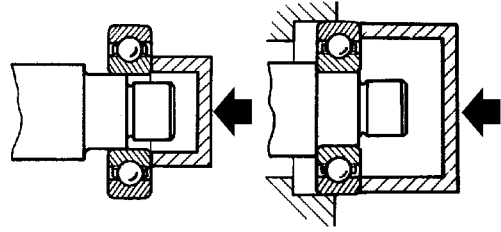

M01 0176

- When fitting a bearing to a shaft, only apply force to the inner ring of the bearing. When fitting a bearing into a housing, only apply force to the outer ring of the bearing.
- In the case of grease lubricated bearings (e.g. hub bearings) fill the space between bearing and outer seal with the recommended grade of grease before fitting seal.
- Always mark components of separable bearings (e.g. taper roller bearings) when dismantling, to ensure correct reassembly. Never fit new rollers in a used outer ring; always fit a complete new bearing assembly.



Connectors should never be subjected to forced removal or refit, especially inter-board connectors. Damaged contacts can cause short-circuit and open-circuit fault conditions.

Prior to commencing test, and periodically during a test, touch a good vehicle body earth to discharge static charge. Some electronic components are vulnerable to the static electricity that may be generated by the operator.

#### **Grease for electrical connectors**

Some under bonnet and under body connectors may be protected against corrosion by the application of a special grease during vehicle production. Should connectors be disturbed in service, or repaired or replaced, additional grease should be re-applied: Part No. BAU 5811, available in 150 gm tubs.

*NOTE: The use of greases other than BAU 5811 must be avoided as they can migrate into relays, switches etc. contaminating the contacts and leading to intermittent operation or failure.*

---

## **Supplementary restraint system precautions**

---

### **General**

The Supplementary Restraint System (SRS) provides active protection for vehicle occupants in the event of a serious collision. The system components include airbags and pre-tensioner seatbelts which are automatically deployed when a severe frontal crash condition is detected.

The SRS pyrotechnic components could be potentially hazardous to the service engineer if not handled correctly. The following guidelines are intended to alert the service engineer to potential sources of danger and emphasise the importance of ensuring the integrity of SRS components fitted to the vehicle.

In order to assure system integrity, it is essential that the SRS system is regularly checked and maintained so that it is ready for operation in the event of an accident.

Where necessary, additional specific precautions are detailed in the relevant sections of this Manual which should be referred to prior to commencing repair operations.

***WARNING: Always follow the 'SRS Precautions' and the correct procedures for working on SRS components. Persons working on SRS systems must be fully trained and have been issued with copies of the Safety guidelines.***

***WARNING: It is imperative that before any work is undertaken on the SRS system the appropriate information is read thoroughly.***

***WARNING: The airbag module contains sodium azide which is poisonous and extremely flammable. Contact with water, acid or heavy metals may produce harmful or explosive compounds. Do not dismantle, incinerate or bring into contact with electricity, before the unit has been deployed.***

***WARNING: Always replace a seat belt assembly that has withstood the strain of a severe vehicle impact, or if the webbing shows signs of fraying.***

***WARNING: Always disconnect the vehicle battery before carrying out any electric welding on a vehicle fitted with an SRS system.***

***CAUTION: Do not expose an airbag module or seat belt pre-tensioner to heat exceeding 85° C (185° F).***

## GENERAL INFORMATION

---

When a major repair has been completed, a leak test should be conducted; refer to the air conditioning section of this manual for the correct procedure.

### Refrigerant oil

Use an approved refrigerant lubricating oil:

ND Oil 8

**CAUTION: Do not use any other type of refrigerant oil.**

**CAUTION: Refrigerant oil easily absorbs water and must not be stored for long periods. Do not pour unused oil back into the container.**

When renewing system components, add the quantities of refrigerant oil recommended in the Air Conditioning section of this manual.

### Compressor

A new compressor is sealed and pressurised with Nitrogen gas. When fitting a new compressor, slowly release the sealing cap; gas pressure should be heard to vent as the seal is broken.

**CAUTION: A new compressor should always be sealed and could be pressurised with nitrogen gas. To avoid possible oil loss, release the sealing cap(s) slowly. Do not remove the cap(s) until immediately prior to connecting the air conditioning pipes to the compressor.**

### Rapid refrigerant discharge

If the air conditioning system is involved in accident damage and the system is punctured, the refrigerant will discharge rapidly. The rapid discharge of refrigerant will also result in the loss of most of the oil from the system. The compressor must be removed and all the remaining oil in the compressor drained and refilled in accordance with the 'Air Conditioning Compressor Replacement Procedure'.

---

## Air conditioning compressor replacement

---

A new compressor is supplied filled with a full charge of (X cm<sup>3</sup>) of refrigerant oil.

A new compressor is supplied with an oil fill (X cm) of 120 cm<sup>3</sup>.

A calculated quantity of oil must be drained from the new compressor before fitting. To calculate the quantity of oil to be drained:

- 1 Remove the drain plug from the old compressor.
- 2 Invert the compressor and gravity drain the oil into a calibrated measuring cylinder. Rotate the compressor clutch to ensure the compressor is completely drained.
- 3 Note the quantity of oil drained (Y cm<sup>3</sup>).
- 4 Calculate the quantity of oil to be drained from the new compressor using the following formula:  
$$X \text{ cm}^3 - (Y \text{ cm}^3 + 20 \text{ cm}^3) = Q \text{ cm}^3$$
- 5 Remove the drain plug from the new compressor and drain Q cm<sup>3</sup> of oil.
- 6 Fit and tighten the compressor drain plug.

### System components

When renewing system components, add the following quantities of refrigerant oil:

- Condenser = 40 cm<sup>3</sup>
- Evaporator = 30 cm<sup>3</sup>
- Receiver drier = 15 cm<sup>3</sup>
- Pipe or hose = 5 cm<sup>3</sup>



<b>General</b>	
⇒ Type / position	Glacier AS15 - thrust washer halves at top and bottom of rear main bearing, oil grooves in top and bottom halves
⇒ Thrust washer halves thickness	2.61 - 2.65 mm (0.103 - 0.104 in.)
<b>Main bearing thickness:</b>	
⇒ Red	1.930 - 1.927 mm (0.0760 - 0.0759 in.)
⇒ Blue	1.927 - 1.924 mm (0.0759 - 0.0757 in.)
⇒ Green	1.924 - 1.921 mm (0.0757 - 0.0756 in.)
⇒ Yellow	1.921 - 1.918 mm (0.0756 - 0.0755 in.)
⇒ Black	1.918 - 1.915 mm (0.0755 - 0.0754 in.)
<b>Big-end bearings</b>	
Material / Type	Glacier AS15 - plain upper and lower half shells with locating tags
Clearance in bearings	0.022 - 0.040 mm (0.0009 - 0.0016 in.)
<b>Big-end bearing thicknesses:</b>	
⇒ Red	1.803 - 1.800 mm (0.0710 - 0.0709 in.)
⇒ Blue	1.800 - 1.797 mm (0.0709 - 0.0707 in.)
⇒ Green	1.797 - 1.794 mm (0.0707 - 0.0706 in.)
⇒ Yellow	1.794 - 1.791 mm (0.0706 - 0.0705 in.)
⇒ Black	1.791 - 1.788 mm (0.0705 - 0.0704 in.)
Big-end end-float	0.19 - 0.29 mm (0.007 - 0.011 in.)
<b>Connecting rods</b>	
Type	Forged steel H-sections with horizontally split big-ends
Distance between centres	151.31 - 151.41 mm (5.957 - 5.961 in.)
<b>Gudgeon pins</b>	
Type	Semi-floating offset towards thrust side
<b>Fit in connecting rods</b>	
⇒ Diameter - Red coded	17.997 - 18.000 mm (0.7085 - 0.7087 in.)
⇒ Diameter - Green coded	17.994 - 17.997 mm (0.7084 - 0.7085 in.)
⇒ Length	52.3 - 52.6 mm (2.059 - 2.071 in.)
⇒ Clearance in piston	0.011 mm (0.0004 in.)
<b>Pistons</b>	
Type	Aluminium alloy, tin plated, thermal expansion with offset gudgeon pin
<b>Piston diameter (at right angle to gudgeon pin and 10 mm (0.4 in. from bottom of skirt):</b>	
⇒ Grade A	79.965 - 79.980 mm (3.1482 - 3.1488 in.)
⇒ Grade B	79.981 - 79.995 mm (3.1489 - 3.1494 in.)
Clearance in bore 20 mm (0.75 in.) from bottom of cylinder bore	0.034 - 0.035 mm (0.0013 - 0.0014 in.)
Maximum ovality	0.3 mm (0.012 in.)
<b>Piston rings</b>	
<b>Type:</b>	
⇒ Top compression ring	Chrome plated steel
⇒ 2nd compression ring	Chrome plated cast iron
⇒ Oil control ring	Stainless steel top and bottom rails with expander ring
<b>New ring to groove clearance:</b>	
⇒ Top compression ring	0.05 - 0.08 mm (0.0020 - 0.0031 in.)
⇒ 2nd compression ring	0.04 - 0.07 mm (0.0012 - 0.0024 in.)
⇒ Oil control ring	0.010 - 0.180 mm (0.0004 - 0.0071 in.)
Ring fitted gap 20 mm (0.75 in) from top of bore:	

# GENERAL DATA

## Manual Gearbox – PG1

Gear ratios:	
⇒ First	3.250 : 1 (19.902 : 1 overall)
⇒ Second	1.894 : 1 (11.598 : 1 overall)
⇒ Third	1.222 : 1 (7.483 : 1 overall)
⇒ Fourth	0.848 : 1 (5.019 : 1 overall)
⇒ Fifth	0.649 : 1 (3.974 : 1 overall)
⇒ Reverse	3.000 : 1
Reverse idler gear to selector fork clearance	0.5 to 1.1 mm (0.020 - 0.043 in)
Selector fork prong width	13.0 to 13.3 mm (0.512 - 0.524 in)
Selector fork groove to pin clearance:	
⇒ Standard	0.05 to 0.35 mm (0.002 - 0.014 in)
⇒ Service limit	0.50 mm (0.020 in)
Selector fork groove width	7.05 to 7.25 mm (0.278 - 0.285 in)
Gearshift arm to guide clearance:	
⇒ Standard	0.20 to 0.30 mm (0.008 - 0.012 in)
⇒ Service limit	0.55 mm (0.022 in)
Interlock shift guide groove width	8.10 to 8.20 mm (0.319 - 0.323 in)
Synchro ring to gear clearance:	
⇒ Standard	0.85 to 1.10 mm (0.033 - 0.043 in)
⇒ Service limit (minimum clearance)	0.40 mm (0.016 in)
Selector shaft forks in synchro sleeve grooves clearance:	
⇒ Standard	0.45 to 0.65 mm (0.018 - 0.026 in)
⇒ Service limit	1.00 mm (0.039 in)
Gearshift arm guide to selector fork clearance:	
⇒ Standard	0.20 to 0.50 mm (0.008 - 0.020 in)
⇒ Service limit	0.80 mm (0.031 in)
Gearshift arm guide tongue width	11.90 to 12.00 mm (0.469 - 0.472 in)
Gearshift arm guide to interlock assembly clearance:	
⇒ Standard	0.05 to 0.35 mm (0.002 - 0.014 in)
⇒ Service limit	0.60 mm (0.024 in)
Gearshift arm guide groove width	13.05 to 13.25 mm (0.514 - 0.522 in)
Interlock ball to gearshift arm guide clearance:	
⇒ Standard	0.05 to 0.25 mm (0.002 - 0.010 in)
⇒ Service limit	0.50 mm (0.020 in)
Interlock ball outside diameter	12.05 to 12.15 mm (0.474 - 0.478 in)
2nd to 3rd gear clearance:	
⇒ Standard	0.06 to 0.21 mm (0.002 - 0.008 in)
⇒ Service limit	0.30 mm (0.012 in)
3rd gear thickness:	
⇒ Standard	35.42 to 35.47 mm (1.394 - 1.396 in)
⇒ Service limit	35.30 mm (1.390 in)
4th to 5th gear clearance:	
⇒ Standard	0.06 to 0.21 mm (0.002 - 0.008 in)
⇒ Service limit	0.30 mm (0.012 in)
Spacer collar length:	
⇒ Standard	26.03 to 26.08 mm (1.025 - 1.027 in)
⇒ Service limit	26.01 mm (1.024 in)



## Air Conditioning

System	CFC free, sealed, closed-loop system
Refrigerant	HFC - R134a
Refrigerant charge quantity All models except LHD KV6 LHD KV6 models	540 ± 25 grammes 430 ± 25 grammes
Compressor: ⇒ Type ⇒ Pressure (High side) ⇒ Pressure (Low side) ⇒ Displacement (Min.) ⇒ Displacement (Max.)	Denso - variable displacement, 7-cylinder swash plate unit 35.3 bar (3.53 MPa, 512 lbf/in <sup>2</sup> ) 16.7 bar (1.67 MPa, 242 lbf/in <sup>2</sup> ) 5% 95%
Lubricating oil	Nippon Denso ND-8
Evaporator thermostat: ⇒ Opens ⇒ Closes	+2 °C (+36 °F) -4 °C (+25 °F)
Condenser fan control	PWM signal from ECM to cooling fan control unit
<b>Refrigerant Pressure Sensor</b> Low pressure limit: ⇒ A/C on (pressure rising) ⇒ A/C off (pressure falling) High pressure limit: ⇒ A/C off (pressure rising) ⇒ A/C on (pressure falling)	2.25 ± 0.2 bar (32.6 ± 2.9 lbf/in <sup>2</sup> ) 1.96 ± 0.2 bar (28.4 ± 2.9 lbf/in <sup>2</sup> ) 31.4 ± 2.0 bar (455.3 ± 29 lbf/in <sup>2</sup> ) 25.5 ± 2.0 bar (369.8 ± 29 lbf/in <sup>2</sup> )

# TORQUE WRENCH SETTINGS

## Engine – Td4

TORQUE DESCRIPTION	METRIC	IMPERIAL
Acoustic cover to engine	8 Nm	6 lbf.ft
Ancillary drive belt jockey pulley Allen bolt	24 Nm	18 lbf.ft
Ancillary drive belt tensioner arm nut	10 Nm	7.5 lbf.ft
Big end bearing cap bolts:		
⇒ Stage 1	5 Nm	3.5 lbf.ft
⇒ Stage 2	25 Nm	18 lbf.ft
⇒ Stage 3	+70°	+70°
Camshaft bearing cap bolts †	10 Nm	7.5 lbf.ft
Camshaft cover bolts †	10 Nm	7.5 lbf.ft
Camshaft sprocket retaining screw:		
⇒ Stage 1	20 Nm	15 lbf.ft
⇒ Stage 2	+35°	+35°
Chain lubrication jet bolt	10 Nm	7.5 lbf.ft
Coolant rail to exhaust manifold bolts	20 Nm	15 lbf.ft
Coolant rail to exhaust manifold bolts	8 Nm	6 lbf.ft
Crankshaft pulley:		
⇒ Stage 1	100 Nm	74 lbf.ft
⇒ Stage 2	+60 °	+60 °
⇒ Stage 3	+60 °	+60 °
⇒ Stage 4	+30 °	+30 °
Crankshaft rear oil seal housing:		
⇒ M6 bolts	10 Nm	7.5 lbf.ft
⇒ M8 bolts	22 Nm	16 lbf.ft
Cylinder block reinforcing plate	22 Nm	16 lbf.ft
Cylinder head bolts:		
⇒ Stage 1†	80 Nm	59 lbf.ft
⇒ Stage 2 †	-1/2 turn	-1/2 turn
⇒ Stage 3†	50 Nm	37 lbf.ft
⇒ Stage 4†	+90°	+90°
⇒ Stage 5†	+90°	+90°
⇒ Stage 6 – tighten 41 mm bolt in position 12	110 Nm	81 lbf.ft
Cylinder head to timing cover Allen screws	15 Nm	11 lbf.ft
Dipstick tube to oil filter housing bolt	10 Nm	7.5 lbf.ft
Drive plate to crankshaft bolts †	115 Nm	85 lbf.ft
EGR cooler to cylinder head and lifting bracket bolts	25 Nm	18 lbf.ft
Engine breather pipe to air cleaner housing bolt	10 Nm	7.5 lbf.ft
Engine lifting eye bolts	20 Nm	15 lbf.ft
Engine mounting bracket assembly to engine bolts	100 Nm	74 lbf.ft
Engine mounting bracket to hydramount nut	85 Nm	63 lbf.ft
Engine lower steady bracket bolts:		
⇒ M10	45 Nm	33 lbf.ft
⇒ M12	50 Nm	37 lbf.ft
Engine steady mounting bolt	100 Nm	74 lbf.ft
Exhaust manifold to cylinder head nuts	24 Nm	18 lbf.ft
Flywheel to crankshaft bolts †	115 Nm	85 lbf.ft
Fuel pipe bracket to oil filter housing bolt	10 Nm	7.5 lbf.ft
Fuel pipe union nuts	30 Nm	22 lbf.ft
Fuel pump drive chain lower guide Allen bolt	24 Nm	18 lbf.ft



**Fuel delivery system – Petrol**

TORQUE DESCRIPTION	METRIC	IMPERIAL
Air cleaner to battery tray bolts	9 Nm	7 lbf.ft
Fuel filler neck to body nuts and bolt	9 Nm	7 lbf.ft
Fuel pump/sender unit to tank locking ring	35 Nm	26 lbf.ft
Fuel rail to inlet manifold bolt	8 Nm	6 lbf.ft
Fuel tank to body bolts	40 Nm	29 lbf.ft
Heated Oxygen (HO <sub>2</sub> S) Sensor	40 Nm	29 lbf.ft
Ignition coils to LH inlet manifold nuts and bolts	9 Nm	7 lbf.ft
Inertia (fuel cut-off) switch	2 Nm	1.5 lbf.ft
Intake Air Control Valve (IACV) to throttle body Allen screws	6 Nm	4.5 lbf.ft
Subframe to body bolts	190 Nm	140 lbf.ft
Throttle housing to inlet manifold bolts <sup>1</sup> (K1.8)		
⇒1st. stage	4 Nm	3 lbf.ft
⇒2nd. stage	9 Nm	7 lbf.ft
Throttle body to inlet manifold chamber Torx screws (KV6)	8 Nm	6 lbf.ft
Throttle actuator support bracket to throttle body Torx screws (vehicles with cruise control only)	9 Nm	7 lbf.ft
Throttle position sensor to housing Torx screws	1.5 Nm	1.1 lbf.ft
VIS motor to inlet manifold chamber screws (KV6 only)	8 Nm	6 lbf.ft

<sup>1</sup> Tighten in sequence using the procedure defined in 'Repairs' section.

**ENGINE MANAGEMENT SYSTEM - SIEMENS, REPAIRS, Sensor - combined - manifold absolute pressure/Intake air temperature (MAP/IAT).**

# TORQUE WRENCH SETTINGS

## Automatic Gearbox – Jatco

TORQUE DESCRIPTION	METRIC	IMPERIAL
Air blast cooler assembly to chassis bolts:		
⇒ Lower	10 Nm	7.5 lbf.ft
⇒ Upper	5 Nm	3.5 lbf.ft
Air blast cooler fan cowl to matrix bolts	5 Nm	3.5 lbf.ft
Air blast cooler fan motor to cowl bolts	5 Nm	3.5 lbf.ft
Air blast cooler multiplug mounting bracket nut	10 Nm	7.5 lbf.ft
Air blast cooler pipe union nuts	25 Nm	18 lbf.ft
Crankshaft Position (CKP) Sensor	9 Nm	7 lbf.ft
Closing panel to gearbox panel bolt	10 Nm	7.5 lbf.ft
Drive plate to converter bolts	45 Nm	33 lbf.ft
Earth lead to gearbox housing bolt	25 Nm	18 lbf.ft
Fluid cooler to mounting bracket bolts (KV6)	25 Nm	18 lbf.ft
Fluid cooler mounting bracket bolts (KV6):		
⇒ M8	25 Nm	18 lbf.ft
⇒ M12	85 Nm	63 lbf.ft
Fluid cooler mounting bolts (Td4):		
⇒ 2 off	45 Nm	33 lbf.ft
⇒ 1 off	25 Nm	18 lbf.ft
Fluid cooler hoses to gearbox	18 Nm	13 lbf.ft
Fluid cooler hose unions	18 Nm	13 lbf.ft
Fluid pan bolts †	7 Nm	5 lbf.ft
Gearbox closing plate bolt (Td4)	10 Nm	7.5 lbf.ft
Gearbox drain plug	45 Nm	33 lbf.ft
Gearbox level plug	14 Nm	10 lbf.ft
Gearbox housing to sump	85 Nm	63 lbf.ft
Gearbox to engine bolts	85 Nm	63 lbf.ft
Gearbox mounting bracket bolts	85 Nm	63 lbf.ft
Gearbox mounting through bolt	100 Nm	74 lbf.ft
Inhibitor switch bolts	3 Nm	2.2 lbf.ft
IRD cooling hose retainer bolt (KV6)	25 Nm	18 lbf.ft
IRD support bracket mounting bolts † (KV6)	50 Nm	37 lbf.ft
IRD support bracket to engine front mounting bracket bolts † (KV6)	50 Nm	37 lbf.ft
IRD support bracket to sump bolts † (KV6)	45 Nm	33 lbf.ft
IRD to gearbox bolts (KV6)	80 Nm	59 lbf.ft
Manifold heatshield to IRD support bracket (KV6):		
⇒ Bolts	9 Nm	7 lbf.ft
⇒ Nut	45 Nm	33 lbf.ft
Manifold heatshield to IRD pinion housing nut (KV6)	25 Nm	18 lbf.ft
Selector housing nuts	10 Nm	7.5 lbf.ft
Selector cable trunnion nut	6 Nm	4.5 lbf.ft
Selector lever to gearbox selector shaft nut	25 Nm	18 lbf.ft
Starter motor to gearbox bolts	45 Nm	33 lbf.ft
Torque converter access plate bolts	9 Nm	7 lbf.ft

†Tighten in sequence.



---

**Wipers and Washers**

---

TORQUE DESCRIPTION	METRIC	IMPERIAL
Rear wiper arm nut	13 Nm	10 lbf.ft
Rear wiper motor bolts	5 Nm	3.7 lbf.ft
Rear wiper motor spindle nut	5 Nm	3.7 lbf.ft
Windscreen wiper arm nut	18 Nm	13 lbf.ft
Windscreen wiper motor and linkage to body bolts	5 Nm	3.7 lbf.ft

## MAINTENANCE

---

### K1.8 – Petrol Engine – Under Bonnet View

---

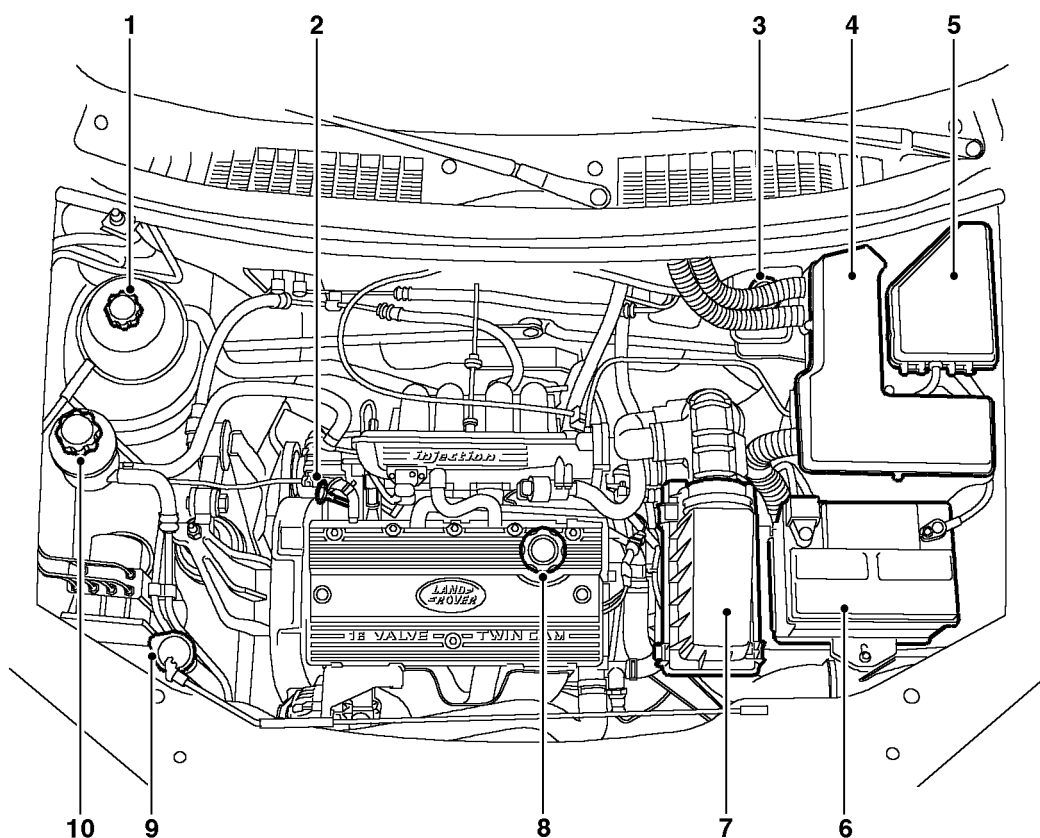

M10 0749

*LHD shown, RHD similar*

- 1 Cooling system expansion tank filler cap
- 2 Engine oil dipstick
- 3 Brake/Clutch fluid reservoir cap
- 4 Engine Control Module box
- 5 Engine compartment fusebox
- 6 Battery
- 7 Air cleaner
- 8 Engine oil filler cap
- 9 Windscreen washer reservoir filler cap
- 10 Power steering reservoir



---

## Spark Plugs – K1.8

---

### Check & Renew

1. Check spark plugs condition and gap. Renew if necessary.

 **ENGINE MANAGEMENT SYSTEM - MEMS, REPAIRS, Spark plugs.**

---

## Spark Plugs – KV6

---

### Check & Renew

1. Check spark plugs condition and gap. Renew if necessary.

 **ENGINE MANAGEMENT SYSTEM - SIEMENS, REPAIRS, Spark plugs.**

# MAINTENANCE

---

---

## Engine Oil and Filter – K1.8

---

### Drain

1. Raise vehicle on ramp.
2. Remove underbelly panel.  
 **EXTERIOR FITTINGS, REPAIRS, Panel - underbelly.**

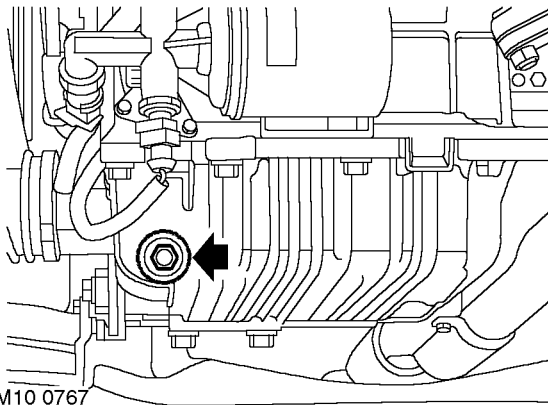

M10 0767



3. Place a suitable container under engine sump drain plug, remove plug and discard sealing washer. Allow oil to drain.

**WARNING: Observe due care when draining engine oil as the oil can be very hot.**

**WARNING: Avoid excessive skin contact with used engine oil. Used engine oil contains potentially harmful contaminants which may cause skin cancer or other serious skin disorders.**

4. Remove and discard engine oil filter.

### Refill

1. Lubricate sealing ring of new filter with clean engine oil.
2. Fit new filter and tighten by hand until it seats, then tighten a further half a turn.
3. Clean sump drain plug and fit new sealing washer.
4. Fit sump drain plug and tighten to 25 Nm (18 lbf.ft).
5. Remove engine oil filler cap and fill engine with oil to correct level.  
 **CAPACITIES, FLUIDS AND LUBRICANTS, Lubrication.**
6. Fit oil filler cap.
7. Fit underbelly panel.  
 **EXTERIOR FITTINGS, REPAIRS, Panel - underbelly.**
8. Lower vehicle.
9. Start engine. Run at idle until oil pressure warning light extinguishes.
10. Stop engine. Recheck engine oil level.
11. Check for signs of leakage.



## Adjust

1. Tie bonnet back in upright position.
2. Remove engine upper steady.
  -  ENGINE - Td4, REPAIRS, Engine steady - upper - RH.

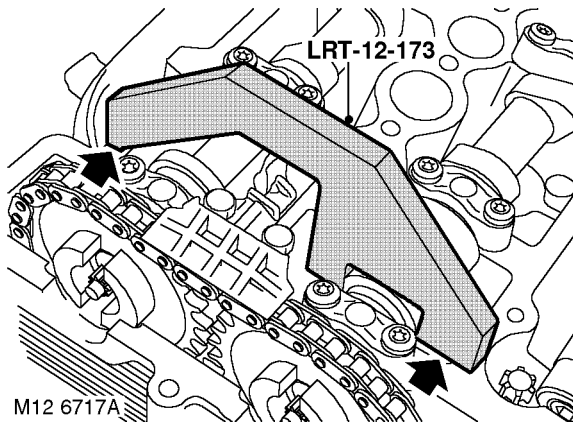

9. Fit **LRT-12-173** to inlet camshaft.
10. If inlet camshaft is timed correctly, **LRT-12-173** will contact both sides of camshaft cover gasket face on cylinder head.

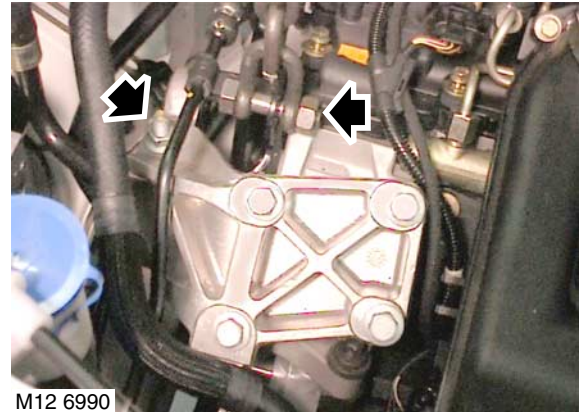

3. Remove nut securing engine RH mounting bracket to hydramount.
4. Fit lifting chains to lifting eye and raise engine for access.

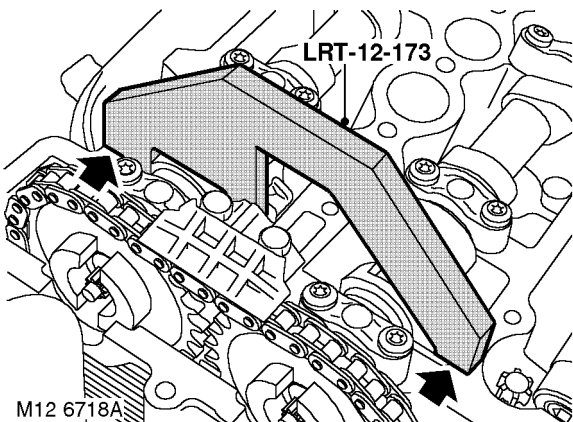

11. Remove **LRT-12-173** from inlet camshaft and fit to exhaust camshaft.
12. If exhaust camshaft is timed correctly, **LRT-12-173** will contact both sides of camshaft cover gasket face on cylinder head.

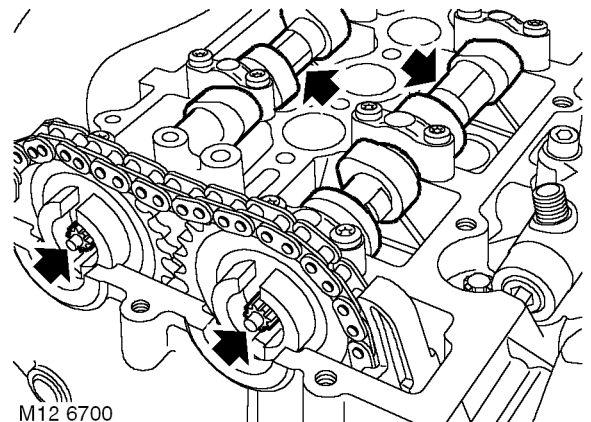

5. With **LRT-12-108** fitted to lock crankshaft, use a spanner on hexagon to hold camshafts; remove and discard screws securing chain sprockets.
6. Fit new screws to sprockets, tighten screws sufficiently to allow sprockets to rotate with all side play eliminated.

## ENGINE - TD4

---

4. Lubricate pistons, piston rings and cylinder bores with clean engine oil.
5. Check that rings are free to rotate, position ring gaps at 120° to each other and away from the thrust side - LH side of piston - viewed from front of piston.

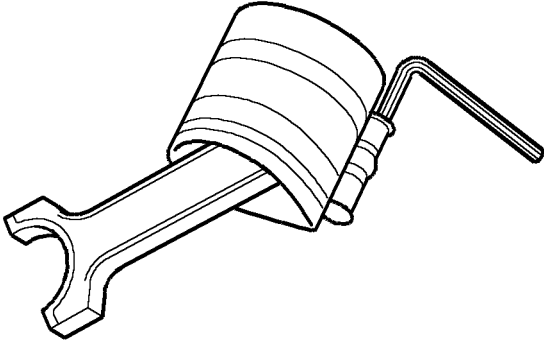

M12 6809

6. Using **LRT-12-204**, compress piston rings.

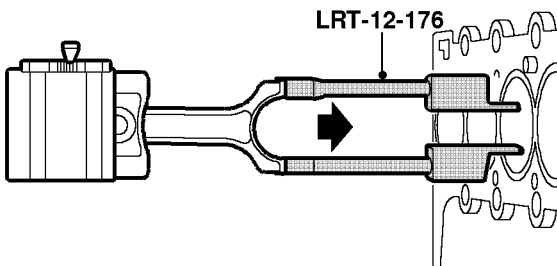

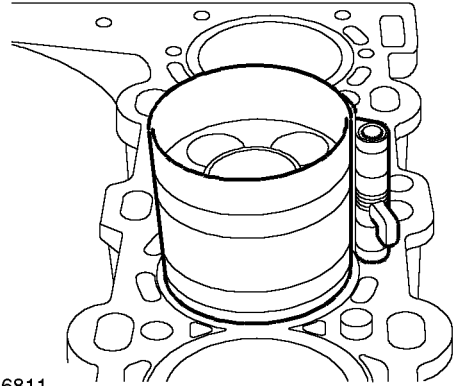

M12 6810A

7. Position **LRT-12-176** guides to connecting rod to protect cylinder bore and bearing journal.



M12 6811

8. Insert connecting rod and piston into cylinder bore, ensuring that the arrow on piston crown is facing towards the front of the cylinder block.
9. Remove **LRT-12-176** guides from connecting rod.
10. Fit connecting rod bearings.  
 **ENGINE - Td4, REPAIRS, Connecting rod bearings - engine set.**
11. Check piston protrusion.  
 **ENGINE - Td4, ADJUSTMENTS, Piston protrusion - check - head removed.**
12. Fit cylinder head gasket.  
 **ENGINE - Td4, REPAIRS, Gasket - cylinder head - manual models.**
13. Connect battery earth lead.



## Gasket - cylinder head - automatic models

🔑 12.29.02

### Remove

1. Disconnect battery earth lead.
2. Drain cooling system.  
👉 **COOLING SYSTEM - Td4, ADJUSTMENTS, Coolant - drain and refill.**
3. Remove tappets.  
👉 **ENGINE - Td4, REPAIRS, Tappets - head set.**
4. Fit wooden block to jack, position jack under engine sump to support engine.

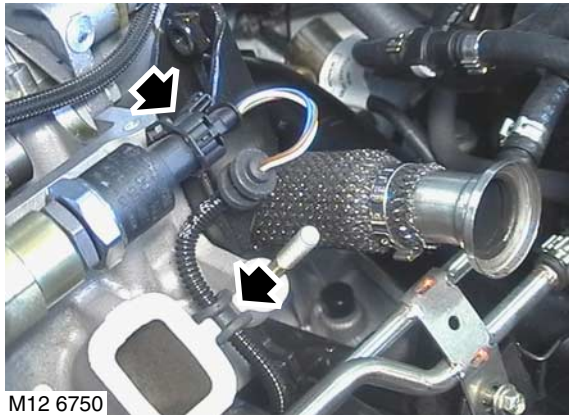

5. Disconnect multiplug from fuel pressure sensor.
6. Release fuel pressure harness grommet from cylinder head.

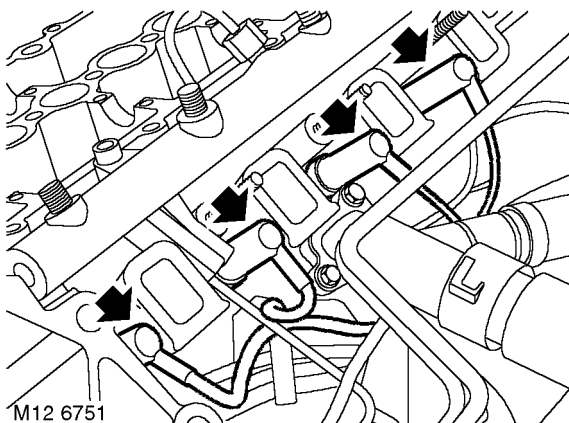

7. Disconnect connections from glow plugs.

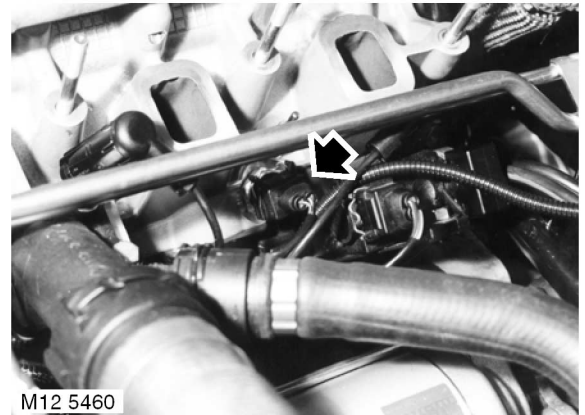

8. Disconnect multiplug from ECT sensor.

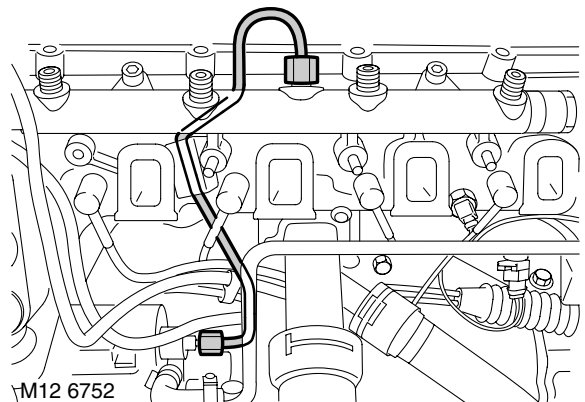

9. Loosen union nuts and remove fuel pipe from fuel rail and pump. Collect fuel pipe support bush.

**CAUTION: Always fit plugs to open connections to prevent contamination.**

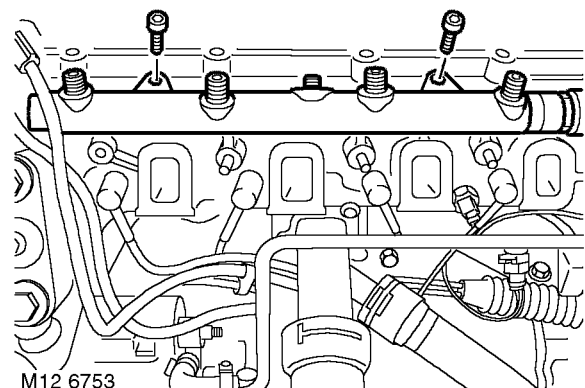

10. Remove 2 Allen screws and remove fuel rail.

## ENGINE - TD4

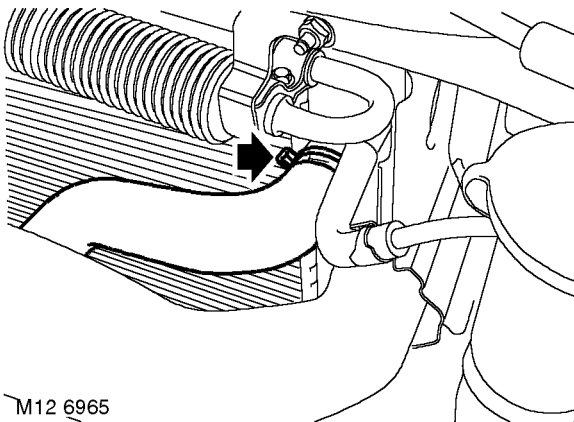

20. Release clip and disconnect top hose from radiator.

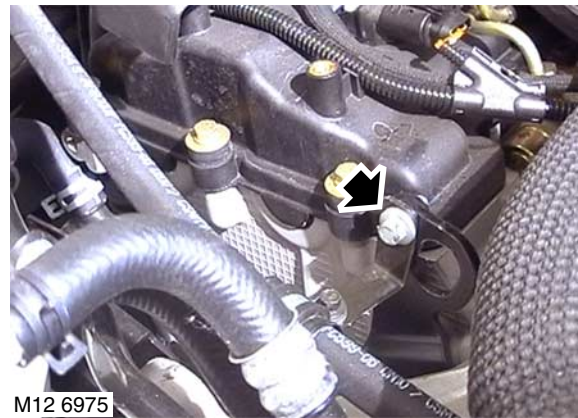

23. Remove bolt securing PAS pipe clip to engine lifting eye.



21. Release clip and remove hose from coolant rail.



24. Place a suitable container beneath PAS reservoir, release clip and return hose from mount. Allow fluid to drain.

**CAUTION: Care must be taken to ensure that oil or fluid does not enter or contaminate the alternator.**

25. Cover alternator to prevent PAS oil contamination.

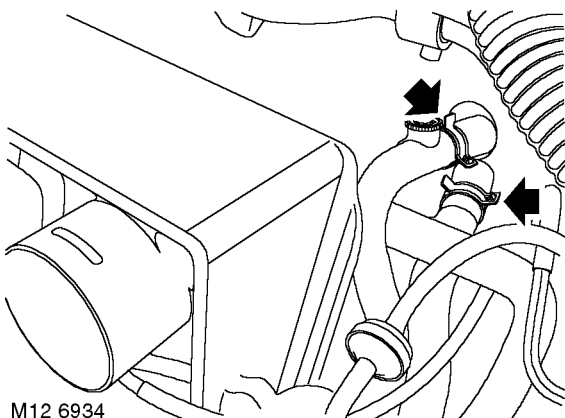

22. Release 2 clips securing heater hoses to heater and release hoses.



9. Fit hydramount.  
**ENGINE - Td4, REPAIRS, Hydramount - engine - RH.**
10. Lower hoist, disconnect and remove lifting bracket, **LRT-12-138.**
11. Fit exhaust front pipe.  
**MANIFOLDS & EXHAUST SYSTEMS - Td4, REPAIRS, Exhaust pipe - front.**
12. Fit propeller shaft to IRD flange and align marks. Tighten nuts and bolts to 40 Nm (30 lbf.ft).
13. Fit rear beam.  
**FRONT SUSPENSION, REPAIRS, Rear beam.**
14. Clean ends of drive shaft and locations in hub and differential.
15. With assistance, fit drive shafts to gearbox, keeping both shafts square to prevent damage to oil seals in gearbox.
16. **Models with A/C:** Position compressor, fit bolts and tighten to 25 Nm (18 lbf.ft).
17. **Models with A/C:** Connect compressor multiplug.
18. **Models with A/C:** Align compressor support bracket to sump and tighten bolt to 10 Nm (7.5 lbf.ft).
19. **Models with A/C:** Fit lower coolant rail to sump and tighten bolts to 10 Nm (7.5 lbf.ft).
20. **Models with A/C:** Ensure compressor drive belt and compressor, crankshaft and tensioner pulleys are clean.
21. **Models with A/C:** Fit compressor drive belt to compressor pulley.
22. **Models with A/C:** Tension compressor drive belt.  
**AIR CONDITIONING, ADJUSTMENTS, Drive belt - compressor - Td4.**
23. Connect coolant hoses to FBH and secure with clips.
24. Clean hoses and vacuum reservoir connections.
25. Connect hoses to vacuum reservoir.
26. Clean hose and vacuum pump connections.
27. Fit vacuum hose and tighten clip.
28. Fit bolt, securing PAS pipe clip to engine lifting eye and tighten to 10 Nm (7.5 lbf.ft).
29. Connect heater hoses and secure with clips.
30. Connect coolant hoses to gearbox fluid cooler and secure clips.
31. Connect coolant hose to coolant rail and secure with clip.
32. Connect top hose to radiator and secure with clip.
33. Connect fuel hoses to clips on fuel rail.
34. Connect hose to intercooler and secure with clip.
35. Connect gearbox harness multiplugs and secure multiplugs in mounting bracket clips.
36. Fit trunnion to selector lever, fit inner cable to trunnion and secure outer cable to abutment bracket.
37. Adjust selector cable.  
**AUTOMATIC GEARBOX - JATCO, ADJUSTMENTS, Selector cable - adjust.**
38. Fit cables to starter motor solenoid and tighten nut to 13 Nm (10 lbf.ft).
39. Position earth lead to gearbox and tighten bolt to 25 Nm (18 lbf.ft).
40. Fit engine harness leads to 'E' box and locate grommets.
41. Fit 'E' box harness straps and tighten screws.
42. Connect multiplugs.
43. Connect multiplug to automatic gearbox ECU.
44. Fit ECM.  
**ENGINE MANAGEMENT SYSTEM - EDC, REPAIRS, Engine control module (ECM).**
45. Refill gearbox with transmission fluid.  
**AUTOMATIC GEARBOX - JATCO, ADJUSTMENTS, Gearbox fluid - drain & refill.**
46. Fill IRD to correct level with fluid.  
**INTERMEDIATE REDUCTION DRIVE, ADJUSTMENTS, Intermediate reduction drive (IRD) fluid - drain & refill - Non NAS.**
47. Fit battery carrier.  
**CHARGING AND STARTING, REPAIRS, Carrier - battery.**
48. Fit intake ducting assembly.
49. Refill cooling system.  
**COOLING SYSTEM - Td4, ADJUSTMENTS, Coolant - drain and refill.**
50. Untie and close bonnet.
51. Connect battery earth lead.

## ENGINE - TD4

---

### Refit

1. Clean oil sump and mating face.

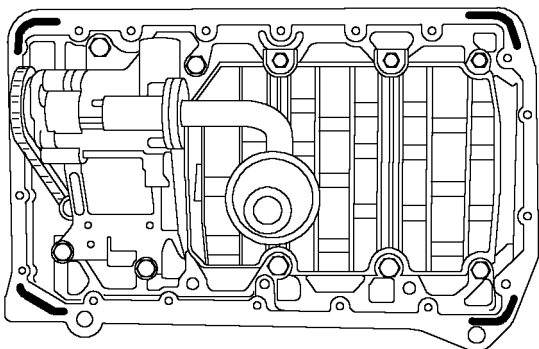

M12 6948

15. Fit splash shield and tighten bolts to 10 Nm (7.5 lbf.ft).
16. Fit road wheel(s) and tighten nuts to 115 Nm (85 lbf.ft).
17. Fit new oil filter and refill engine with oil.  
 **MAINTENANCE, MAINTENANCE, Engine Oil and Filter – Td4.**
18. Connect battery earth lead.

2. Apply a 2 mm bead of sealant Three Bond 1209 to area illustrated.
3. Fit new gasket to sump, position sump to cylinder block, fit bolts but do not tighten at this stage.
4. Fit bolts securing sump to gearbox housing, lightly tighten and then loosen bolts. This will align the rear sump flange to the gearbox.
5. Tighten M8 sump bolts evenly to 28 Nm (18 lbf.ft) and M6 bolts, accessed through gearbox housing, to 10 Nm (7.5 lbf.ft).
6. Tighten bolts securing gearbox housing to sump to 85 Nm (63 lbf.ft).
7. Fit engine lower steady bracket and tighten bolts evenly. Tighten M12 bolts to 50 Nm ((37 lbf.ft) and M10 bolts to 45 Nm (33 lbf.ft).
8. Tighten engine steady bolts to 100 ((74 lbf.ft).
9. **Models with A/C:** Fit compressor mounting bracket and tighten bolts to 25 Nm (18 lbf.ft).
10. **Models with A/C:** Fit compressor and tighten bolts to 25 Nm (18 lbf.ft).
11. Fit lower coolant rail to sump and tighten bolts to 10 Nm (7.5 lbf.ft).
12. **Models with A/C:** Fit compressor drive belt tensioner, fit bolts but do not tighten at this stage.
13. **Models with A/C:** Tension compressor drive belt.  
 **AIR CONDITIONING, ADJUSTMENTS, Drive belt - compressor - Td4.**
14. Fit new 'O' ring and fit dipstick tube. Tighten bolt to 10 Nm (7.5 lbf.ft).

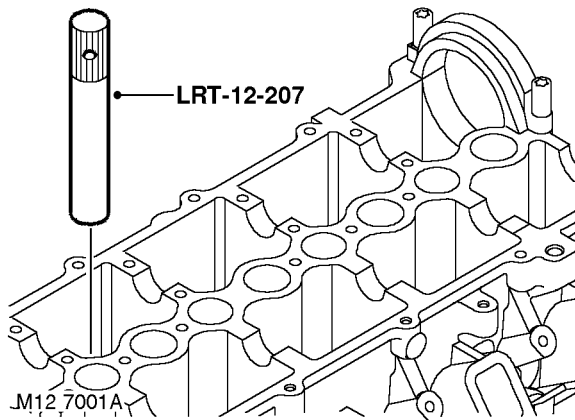

13. Fit seal fully onto valve guide with **LRT-12-207**.
14. Fit valve spring and cap.
15. Use **LRT-12-034** to compress valve spring. Fit collets, release spring and remove **LRT-12-034**.
16. Repeat above for remaining valves.
17. Clean exhaust manifold and cylinder head mating face.
18. Use new gaskets and fit exhaust manifold to cylinder head.
19. Fit nuts securing exhaust manifold and tighten to 24 Nm (18 lbf.ft).

## ENGINE - K SERIES 1.8

15. Release connecting rods from crankshaft journals and carefully push pistons to top of cylinder bore. Remove and discard bearing shells from connecting rods and bearing caps.
16. Rotate crankshaft clockwise and bring numbers 1 and 4 pistons to BDC.
17. Make cylinder number reference marks on big-end bearing caps.
18. Remove 4 dowel bolts and 2 big-end bearing caps from numbers 1 and 4 connecting rods. Keep dowel bolts and bearing caps in their fitted order.
19. Release connecting rods from crankshaft journals and carefully push pistons to top of cylinder bore. Remove and discard bearing shells from connecting rods and bearing caps.

### Refit

1. Using a micrometer, measure crankshaft big-end journal diameters, taking 4 measurements around each journal.

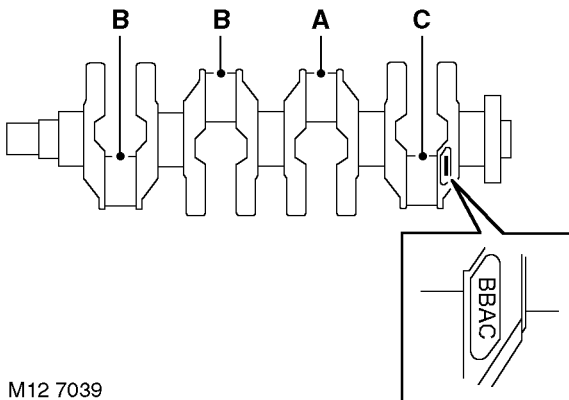

2. Record big-end journal code letters from crankshaft rear web. Reading from left to right, the first letter is Number 1 big-end bearing.



**GENERAL DATA, Engine – K1.8**

**Petrol.**

M12 7040

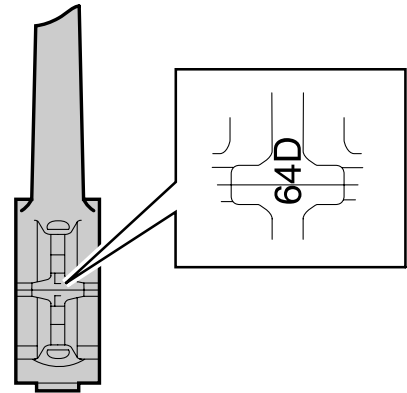

3. Record big-end bearing bore numbers. This will be 5, 6 or 7 located on the connecting rod bearing cap. Select required bearings.



**GENERAL DATA, Engine – K1.8**

**Petrol.**

4. Colour code on edge of bearing denotes bearing thickness as follows: YELLOW = Thin, BLUE = Intermediate, RED = Thick. If two bearing colours are to be used, the thicker bearing must be fitted to the big-end bearing cap.
5. Clean crankshaft journals and bearing locations in connecting rods.
6. Select the appropriate big-end bearing shells.
7. Lubricate connecting rod journals and bearing shells with clean engine oil.
8. Fit bearing shells to connecting rods and caps.
9. Carefully pull connecting rods into place, fit big end caps noting that featherways are on opposite sides and lightly tighten dowel bolts.
10. Tighten big-end bearing dowel bolts to:
  - Stage 1 - 20 Nm (15 lbf.ft)
  - Stage 2 - Further 45°

*Note: Until the cylinder head is fitted, crankshaft will prove difficult to rotate once big-end bolts are tightened.*

11. Using feeler gauges, check that end-float of each big-end bearing/connecting rod is between 0.10 (0.004 in) to 0.25 mm (0.010 in).
12. Clean oil rail, oil pick up and mating faces.
13. Blow out oil ways in oil rail and oil pick up.
 

**CAUTION: A new oil rail must be fitted if a thread is damaged. Thread inserts (Helicoil) are not acceptable.**

14. Temporarily remove cylinder liner clamps, **LRT-12-144.**

**CAUTION: Do not rotate crankshaft with liner clamps removed. Ensure that cylinder head bolts used to retain clamps are kept in their original fitted order.**



## Valve stem oil seal

🔑 12.30.26

### Remove

1. Disconnect battery earth lead.
2. Remove camshafts.
3. Using a stick magnet, remove tappet from valve to be worked on.

**CAUTION: Store tappet(s) upright and in their fitted order.**

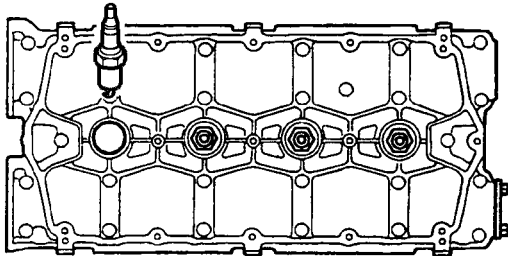

M12 7065

4. Using a 16 mm spark plug socket, remove spark plug.

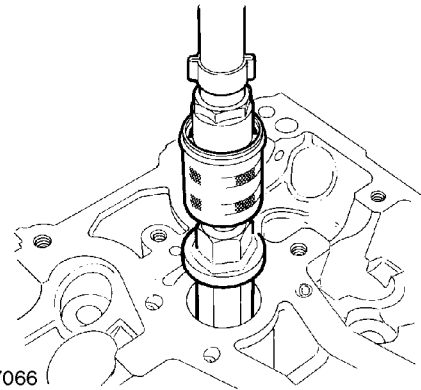
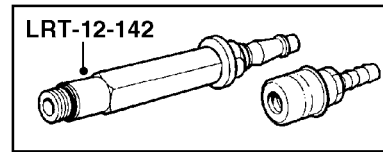

M12 7066

5. Fit and tighten air line adapter tool **LRT-12-142** into spark plug hole.
6. Connect an airline to adaptor and apply air pressure.

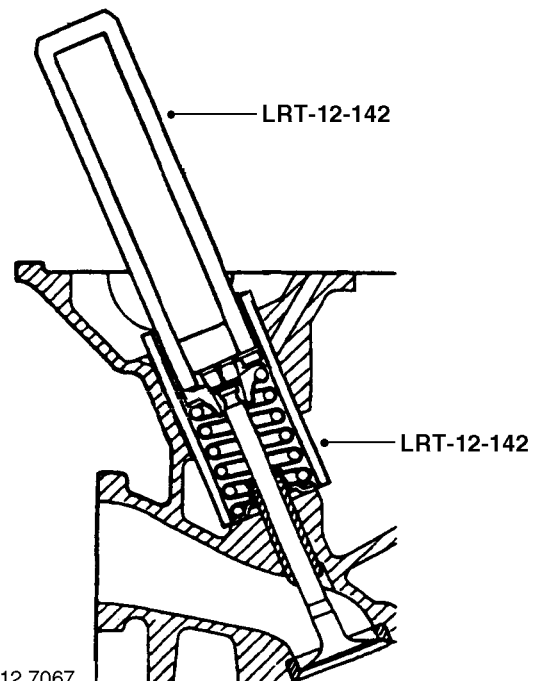

M12 7067

7. Fit sleeve part of tool **LRT-12-142** over valve spring.
8. Fit tool **LRT-12-142** to valve spring cap and strike head of tool firmly with hammer to release valve spring collets.

## ENGINE - K SERIES 1.8

---

### Refit

1. Fit top arm.
2. Fit bolts securing top arm to engine front mounting bracket and tighten to 170 Nm (125 lbf.ft).
3. Lower and remove jack supporting engine.
4. Fit nut securing top arm to RH hydramount and tighten to 85 Nm (63 lbf.ft).
5. Position upper RH engine steady to top arm, fit and tighten bolt to 80 Nm (59 lbf.ft).
6. Tighten bolt securing upper RH engine steady to body to 80 Nm (59 lbf.ft).
7. Fit underbelly panel.

 **EXTERIOR FITTINGS, REPAIRS, Panel - underbelly.**

---

### Hydramount - engine - RH

---

 12.45.12

### Remove

1. Disconnect battery earth lead.
2. Remove engine RH mounting arm assembly.  
 **ENGINE - K SERIES 1.8, REPAIRS, Arm assembly - engine mounting RH.**

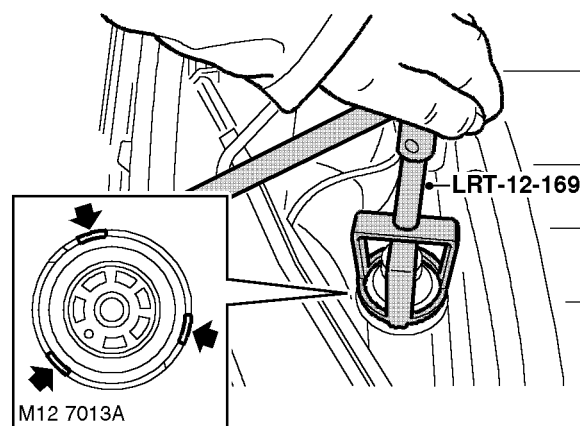

3. Using **LRT-12-169** loosen and remove hydramount.

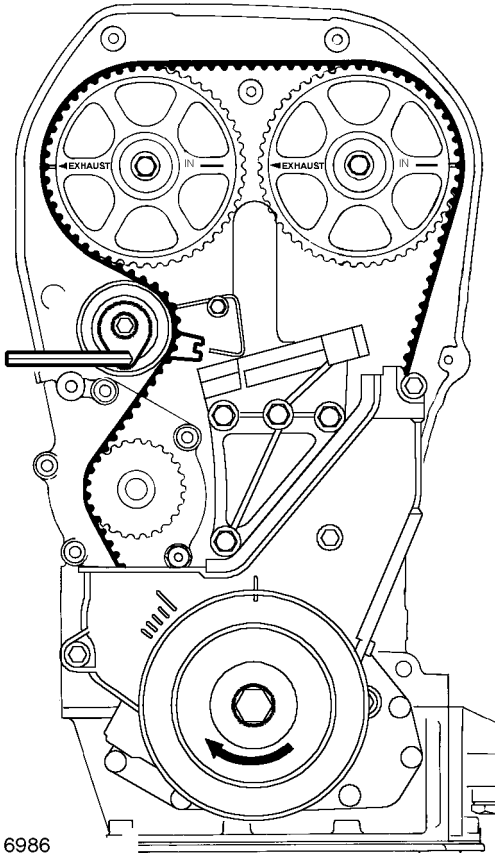

### Refit

1. Clean hydramount and body mating faces.
2. Fit hydramount.
3. Fit RH engine mounting arm assembly.  
 **ENGINE - K SERIES 1.8, REPAIRS, Arm assembly - engine mounting RH.**
4. Connect battery earth lead.



M12 6986

13. Rotate crankshaft 2 turns clockwise and align camshaft gear timing marks.  
**CAUTION: Never use the camshaft gear, the camshaft gear retaining bolts or the timing belt to turn the crankshaft.**
14. Check that pointer is correctly aligned with index wire.
15. If pointer is not correctly aligned, loosen bolt until it is just possible to move tensioner lever. Rotate tensioner lever clockwise until tension is completely backed off, then rotate tensioner lever anti-clockwise until pointer is aligned correctly to index wire.
16. Ensuring pointer maintains correct position, tighten tensioner bolt to 22 Nm (16 lbf.ft).
17. Rotate crankshaft 2 turns clockwise and align camshaft gear timing marks.
18. Check alignment of pointer to index wire, if incorrect, repeat adjustment procedure.
19. Remove crankshaft pulley.

20. Position flywheel locking tool, **LRT-12-145**, in starter motor aperture and secure with 2 bolts.
21. Fit camshaft timing belt upper cover.  
 **ENGINE - K SERIES 1.8, REPAIRS, Cover - timing gear - upper.**
22. Fit hydramount.  
 **ENGINE - K SERIES 1.8, REPAIRS, Hydramount - engine - RH.**
23. Connect battery earth lead.

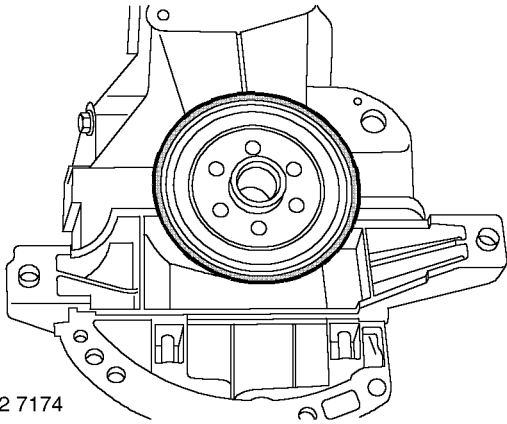

M12 7174

22. Using a burr free flat ended screwdriver, ease crankshaft rear oil seal from cylinder block and discard seal. Take care to not mark sealing surface on crankshaft.

## Refit

1. Remove all traces of oil and sealant from cylinder block, oil seal recess and running surface of crankshaft.

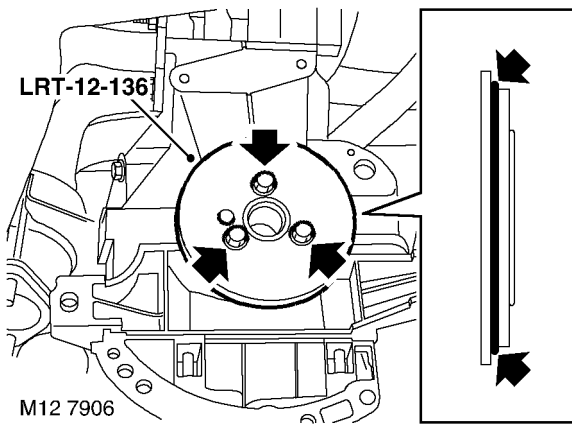

M12 7906

2. Apply a 1.5 mm (0.06 in) bead of sealant, Part Number STC 50550 to new oil seal as shown.
3. Immediately position oil seal to cylinder block.  
**CAUTION: Oil seal must be fitted dry.**
4. Fit oil seal replacer **LRT-12-136** to crankshaft, retain using 3 bolts.
5. Tighten oil seal replacer bolts progressively to press oil seal into cylinder block, leave tool **LRT-12-136** in position for 1 minute.
6. Remove tool **LRT-12-136**.  
**CAUTION: Allow sealant to cure for 30 minutes before rotating crankshaft or topping-up engine oil.**

7. Clean bolt holes in crankshaft using an old drive plate bolt with two saw cuts at an angle of 45 ° to the bolt shank.
8. Clean flywheel and mating face of crankshaft.
9. Fit flywheel to crankshaft.
10. Position flywheel locking tool, **LRT-12-190** to engine and secure with bolt.
11. Fit new Patchlok bolts securing flywheel to crankshaft and working in a diagonal sequence, tighten bolts to 80 Nm (59 lbf.ft).
12. Position drive plate to flywheel with 'FLYWHEEL SIDE' marking towards flywheel.
13. Fit pressure plate to flywheel and position clutch alignment tool, **LRT-12-151**.
14. Fit 6 bolts securing pressure plate to flywheel, tighten bolts sufficiently until drive plate is held in its central position. Remove **LRT-12-151** from pressure plate.
15. Working in a diagonal sequence, progressively tighten pressure plate bolts to 25 Nm (18 lbf.ft).
16. Remove flywheel locking tool, **LRT-12-190**
17. Clean mating faces of engine and gearbox, dowel and dowel holes.
18. With assistance, position gearbox to engine, align to clutch assembly then locate on dowels.
19. Correctly position engine earth lead, fit top 2 bolts securing gearbox to engine.
20. Position front cover plate and fit nuts and bolts.
21. Tighten top bolts and front nuts and bolts to 80 Nm (59 lbf.ft) and gearbox to sump to 45 Nm (33 lbf.ft).
22. Position plain washer to M6 bolt, fit bolt and nut and tighten to 9 Nm (7 lbf.ft).
23. With assistance position IRD unit to gearbox, fit and tighten bolts to 90 Nm (66 lbf.ft).
24. Position support bracket to IRD unit and engine sump, fit and tighten bolts securing support bracket to IRD to 50 Nm (37 lbf.ft) and bolts securing support bracket to engine sump to 45 Nm.
25. Fit and tighten upper bolt securing IRD support bracket to cylinder block to 45 Nm (33 lbf.ft).
26. Position engine lower steady bracket to sump, fit and tighten bolts to 100 Nm (74 lbf.ft).
27. Connect coolant hoses to IRD unit and secure with clips.
28. Secure IRD unit breather hose in clip on dipstick tube.
29. Clean starter motor and mating face on gearbox.
30. Position rear cover plate to cylinder block.
31. Fit starter motor and lower nut and bolt but do not tighten at this stage.
32. Fit engine steady bar, fit bolt securing steady bar to LH engine mounting but do not tighten at this stage.
33. Fit starter motor upper nut and bolt.



## Cylinder head - overhaul

🔑 12.29.19.01

### Remove

1. Remove cylinder head.

👉 **ENGINE - K SERIES 1.8, OVERHAUL, Gasket - cylinder head - unit removed.**

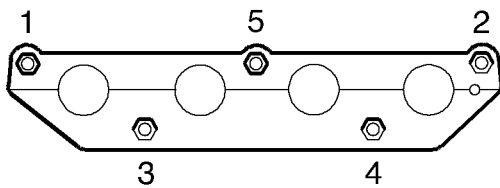

M12 7909

2. Using sequence shown, progressively loosen and remove 5 nuts securing exhaust manifold to cylinder head and remove manifold.
3. Remove and discard exhaust manifold gasket.

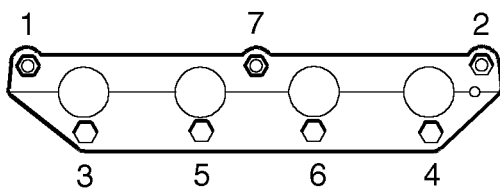

M30 1057

4. Using sequence shown, progressively loosen and remove 7 nuts securing inlet manifold to cylinder head.
5. Remove inlet manifold and discard gasket.

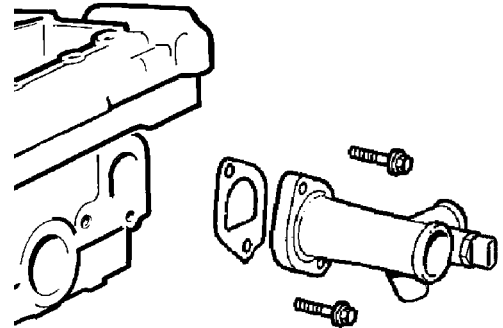

M12 7099

6. Remove 2 bolts securing coolant outlet elbow to cylinder head. Remove elbow and discard gasket.
7. Remove spark plugs.

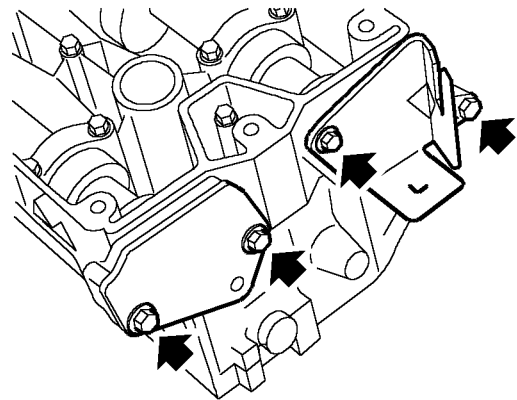

M12 7100

8. Remove 4 bolts securing front and rear camshaft end covers to cylinder head and remove end covers.

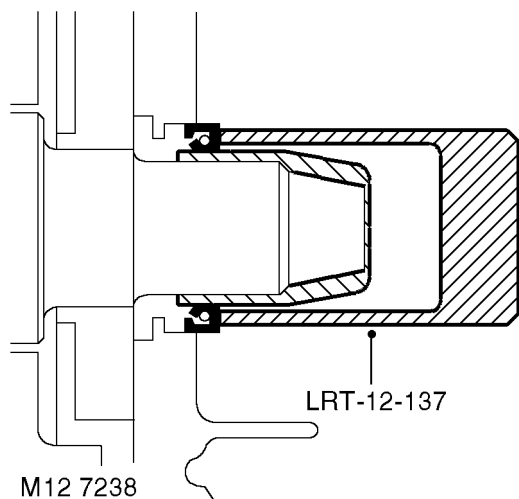

7. Fit seal guide from crankshaft front oil seal kit over front of crankshaft.
8. Fit new oil seal using tool **LRT-12-137**.  
**CAUTION: Oil seal must be fitted dry.**
9. Clean crankshaft gear.
10. Fit camshaft timing belt.  
 **ENGINE - K SERIES 1.8, OVERHAUL, Camshaft timing belt.**

## Sump

 12.60.38.01

### Remove

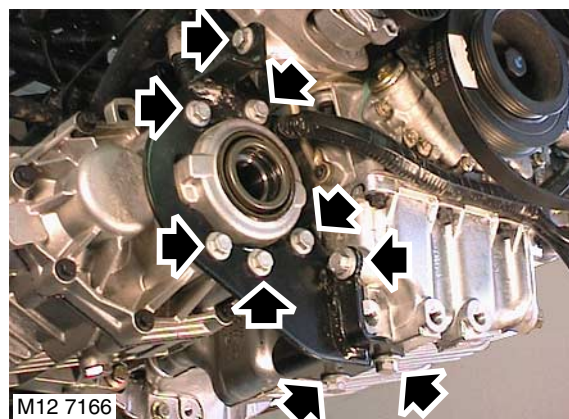

1. Remove upper bolt securing IRD support bracket to cylinder block.
2. Remove 5 bolts securing support bracket to IRD.
3. Remove 3 bolts securing IRD support bracket to sump and remove bracket.

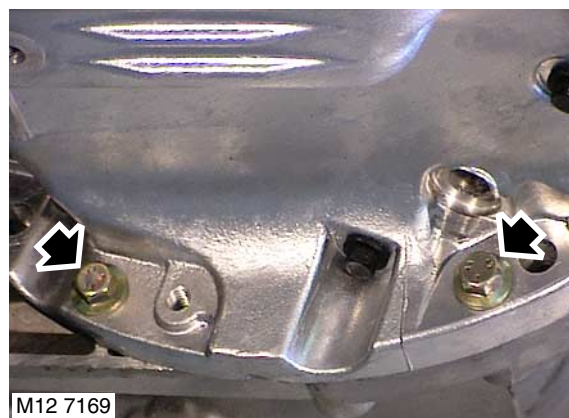

4. Remove 2 bolts securing sump to gearbox.



13. Top-up engine oil.  
 **MAINTENANCE, MAINTENANCE, Engine Oil and Filter – KV6.**
14. Connect battery earth lead.

## Camshafts - RH cylinder head

 12.13.03

### Remove

1. Disconnect battery earth lead.
2. Remove camshaft timing belt.  
 **ENGINE - K SERIES KV6, REPAIRS, Camshaft timing belt.**
3. Remove RH rear camshaft timing belt.  
 **ENGINE - K SERIES KV6, REPAIRS, Camshaft rear timing belt - RH cylinder head.**
4. Remove RH camshaft cover gasket.  
 **ENGINE - K SERIES KV6, REPAIRS, Camshaft cover gasket - RH.**

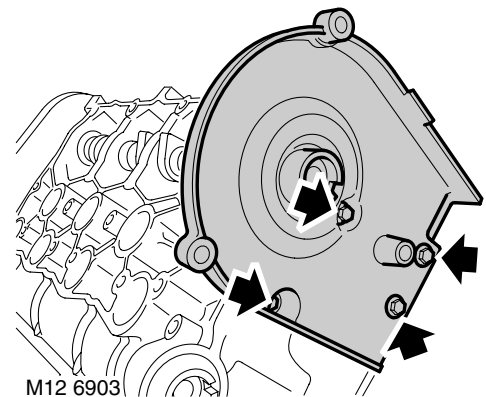



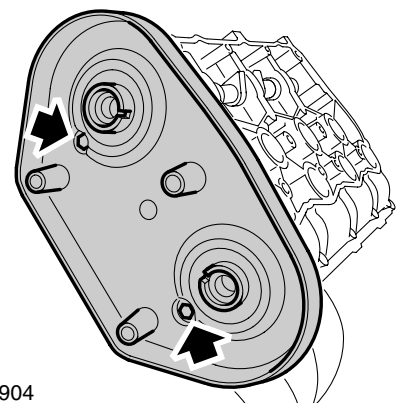



5. Remove 4 bolts securing RH front timing belt cover backplate to cylinder head and remove backplate.



6. Remove 2 bolts securing RH rear timing belt cover backplate and remove backplate.





## ENGINE - K SERIES KV6

16. Position fuel rail assembly and secure injectors to inlet manifolds.
17. Position injector protection cover - if fitted to RH fuel rail and secure injector harness to protection cover or fuel rail with clips.
18. Fit bolts securing fuel rail to inlet manifolds and tighten to 9 Nm (7 lbf.ft).
19. Position CMP sensor bracket, fit and tighten bolt to 9 Nm (7 lbf.ft).
20. Connect CMP sensor multiplug and secure to bracket.
21. Connect breather hose to LH inlet manifold.
22. Connect coolant bleed hose to inlet manifold and secure with clip.
23. Position ignition coils to LH inlet manifold.
24. Position earth lead, fit nuts and bolts securing ignition coils to LH inlet manifold and tighten to 9 Nm (7 lbf.ft).
25. Position ht lead guide bracket, fit and tighten special bolt.
26. Connect ht leads to spark plugs and secure ht leads in guide clips.
27. Clean camshaft timing belt cover backplate bolts and apply Loctite 242 to the first 3 threads.
28. Position backplate, fit and tighten bolts to 9 Nm.
29. Fit camshaft timing belt.  
 **ENGINE - K SERIES KV6, REPAIRS, Camshaft timing belt.**
30. Fit LH exhaust manifold gasket.  
 **MANIFOLDS & EXHAUST SYSTEMS - K SERIES KV6, REPAIRS, Gasket - exhaust manifold - LH - Non NAS.**  
 **MANIFOLDS & EXHAUST SYSTEMS - K SERIES KV6, REPAIRS, Gasket(s) - exhaust manifold - LH - NAS.**
31. Fit inlet manifold chamber.  
 **MANIFOLDS & EXHAUST SYSTEMS - K SERIES KV6, REPAIRS, Seals - inlet manifold chamber.**
32. Fill cooling system.  
 **COOLING SYSTEM - K SERIES KV6, ADJUSTMENTS, Coolant - drain and refill.**
33. Check engine oil level and top-up if necessary.  
 **MAINTENANCE, MAINTENANCE, Engine Oil and Filter – KV6.**

## Cylinder head gasket - RH

 12.29.03

### Remove

1. Disconnect battery earth lead.
2. Drain cooling system.  
 **COOLING SYSTEM - K SERIES KV6, ADJUSTMENTS, Coolant - drain and refill.**
3. Remove inlet manifold chamber.  
 **MANIFOLDS & EXHAUST SYSTEMS - K SERIES KV6, REPAIRS, Seals - inlet manifold chamber.**
4. Remove RH exhaust manifold gasket.  
 **MANIFOLDS & EXHAUST SYSTEMS - K SERIES KV6, REPAIRS, Gasket - exhaust manifold - RH - Non NAS.**  
 **MANIFOLDS & EXHAUST SYSTEMS - K SERIES KV6, REPAIRS, Gasket(s) - exhaust manifold - RH - KV6 - NAS.**
5. Remove camshaft timing belt.  
 **ENGINE - K SERIES KV6, REPAIRS, Camshaft timing belt.**

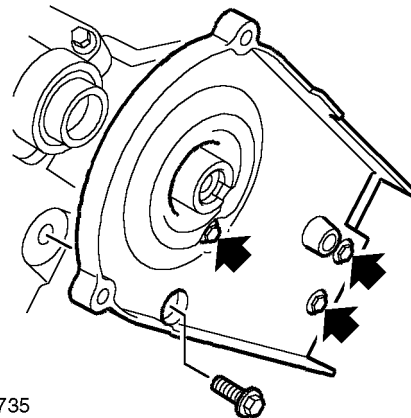

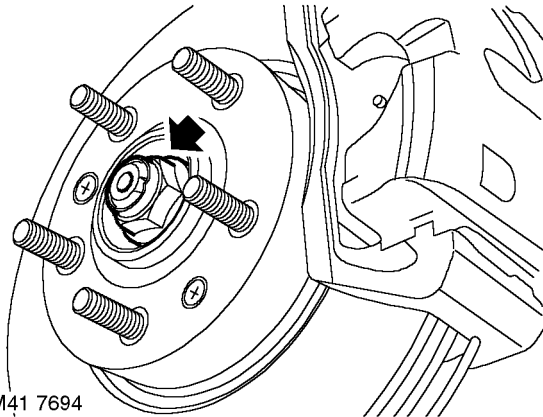

M12 6735

6. Remove 4 bolts securing RH front timing belt cover backplate to cylinder head and remove backplate.



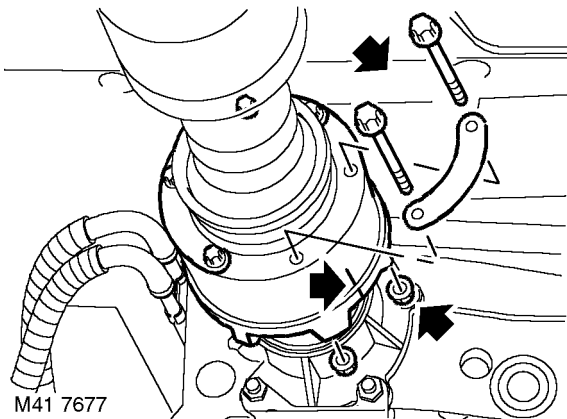

M41 7694

33. With an assistant depressing the brake pedal, remove and discard LH and RH drive shaft nuts.
34. Remove rear beam.  
 **FRONT SUSPENSION, REPAIRS, Rear beam.**
35. Remove exhaust front pipe.  
 **MANIFOLDS & EXHAUST SYSTEMS - K SERIES KV6, REPAIRS, Front pipe - Non NAS.**  
 **MANIFOLDS & EXHAUST SYSTEMS - K SERIES KV6, REPAIRS, Front pipe - NAS.**
36. Raise one rear wheel for rotation of propeller shaft to access bolts.



M41 7677

37. Reference mark position of viscous coupling flange to IRD unit flange to aid reassembly.
38. Remove 6 nuts and bolts securing propeller shaft to IRD drive flange.
39. Release propeller shaft from IRD drive flange and tie shaft aside.  
**CAUTION: Care must be taken to support the Tripode joint when removed from the IRD unit. To avoid damage to gaiter or steel can, the joint should not be allowed to fully extend or be dropped.**

40. Drain gearbox fluid.  
 **AUTOMATIC GEARBOX - JATCO, ADJUSTMENTS, Gearbox fluid - drain & refill.**
41. Drain fluid from IRD.  
 **INTERMEDIATE REDUCTION DRIVE, ADJUSTMENTS, Intermediate reduction drive (IRD) fluid - drain & refill - Non NAS.**  
 **INTERMEDIATE REDUCTION DRIVE, ADJUSTMENTS, Intermediate reduction drive (IRD) lubrication system - drain & refill - NAS.**

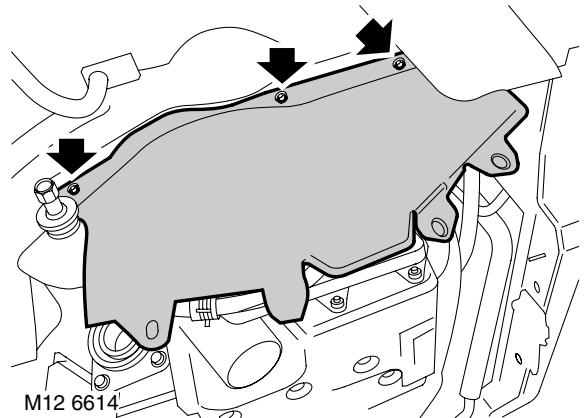

M12 6614

42. Remove 6 bolts securing RH and LH front splash shields and remove shields.

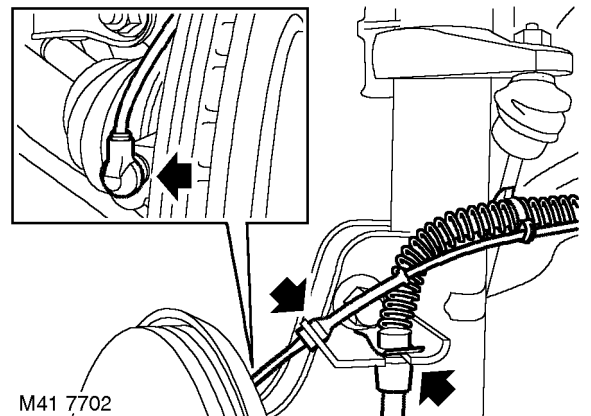

M41 7702

43. Remove clips securing brake hoses to RH and LH damper brackets.
44. Release ABS sensor leads from bracket.
45. Release ABS sensors from RH and LH front hubs.
46. Remove nuts securing RH and LH track rod end ball joints.
47. Fit an M12 nut to each ball pin, flush with end of each pin.

# ENGINE - K SERIES KV6

## Oil pick-up strainer

🔑 12.60.20

### Remove

1. Disconnect battery earth lead.
2. Remove engine sump.  
👉 **ENGINE - K SERIES KV6, REPAIRS, Sump - reseal.**

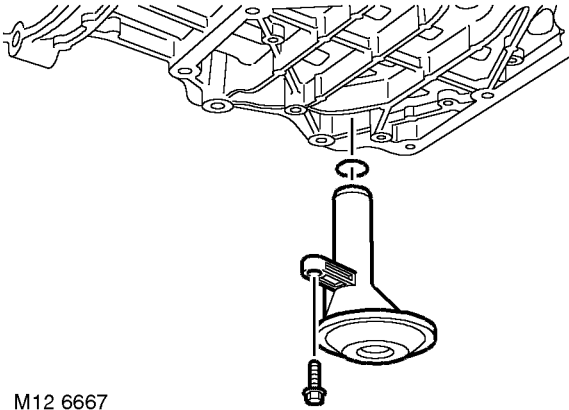

M12 6667

3. Remove bolt and remove oil pick-up strainer. Remove and discard 'O' ring.

### Refit

1. Clean oil pick-up strainer and mating face.
2. Remove all traces of thread locking material from oil strainer bolt hole.  
**CAUTION: Do not use a tap.**
3. Lubricate new 'O' ring with clean engine oil and fit to pick-up strainer.  
**CAUTION: Ensure 'O' ring, Part No. LYX000210L is fitted.**
4. Position oil pick-up strainer, fit and tighten bolt to 8 Nm (6 lbf.ft).
5. Fit engine sump.  
👉 **ENGINE - K SERIES KV6, REPAIRS, Sump - reseal.**
6. Connect battery earth lead.

## Gasket - oil pump

🔑 12.60.25

### Remove

1. Disconnect battery earth lead.
2. Drain engine oil.  
👉 **MAINTENANCE, MAINTENANCE, Engine Oil and Filter – KV6.**
3. Remove camshaft timing belt.  
👉 **ENGINE - K SERIES KV6, REPAIRS, Camshaft timing belt.**

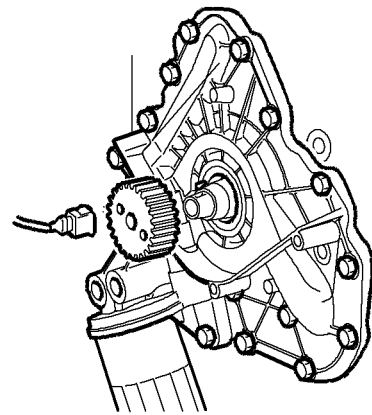

M12 7875

4. Remove crankshaft gear.
5. Disconnect multiplug from oil pressure switch.

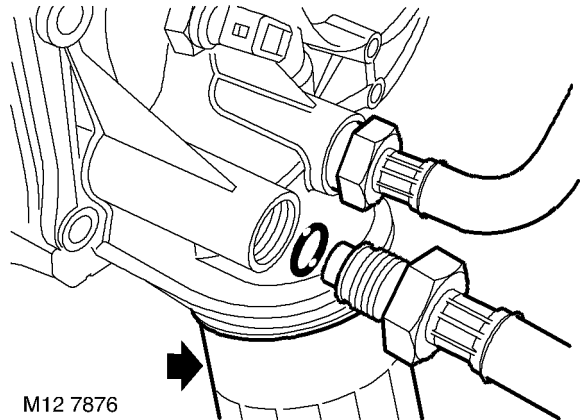

M12 7876

6. Loosen and remove oil cooler pipe unions from oil filter housing, remove and discard 2 'O' rings.
7. Using strap wrench, remove and discard oil filter.

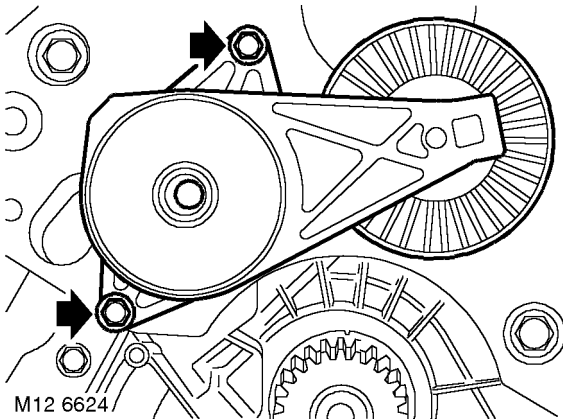

- 27.** Remove 2 bolts securing ancillary drive belt tensioner and remove tensioner.

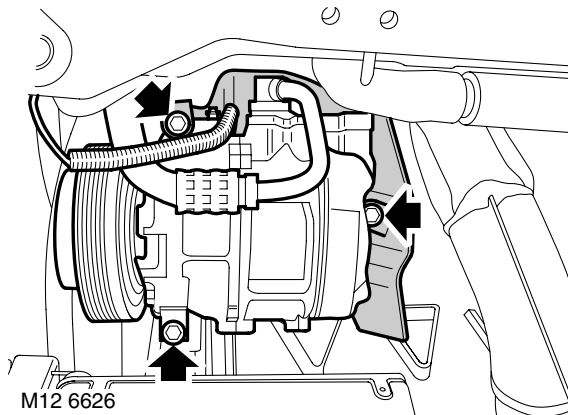

- 28.** Note fitted position of heat shield on A/C compressor and remove 3 bolts securing A/C compressor to front mounting plate and cylinder block. Release A/C compressor and heat shield and position aside.

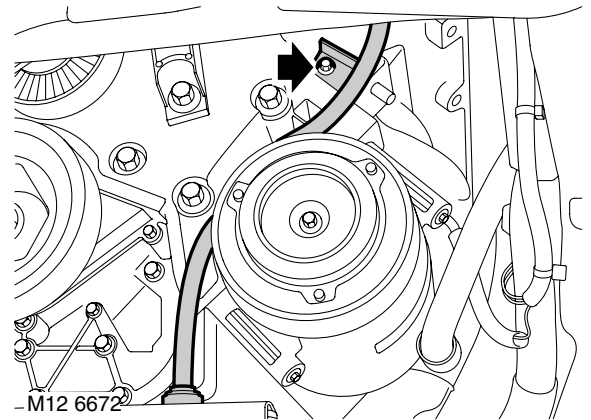

- 29.** Remove bolt securing dipstick tube to cylinder block.  
**30.** Depress and hold down dipstick tube locking collar, remove dipstick tube from engine sump.

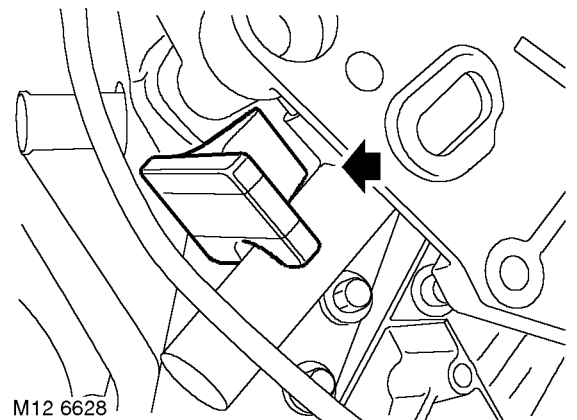

- 31.** Remove rubber blanking plug from around camshaft timing belt tensioner.

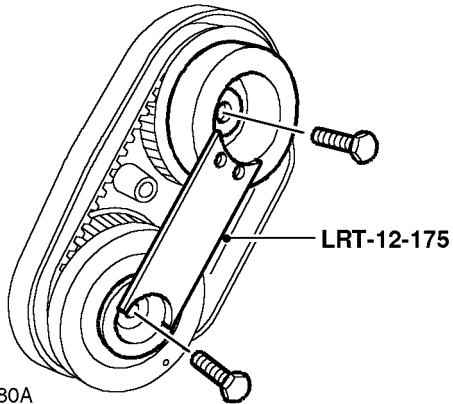

## Camshaft rear timing belt - RH cylinder head

🔑 12.65.57

### Remove

1. Disconnect battery earth lead.
2. Remove underbelly panel.  
👉 **EXTERIOR FITTINGS, REPAIRS, Panel - underbelly.**
3. Remove RH front road wheel.

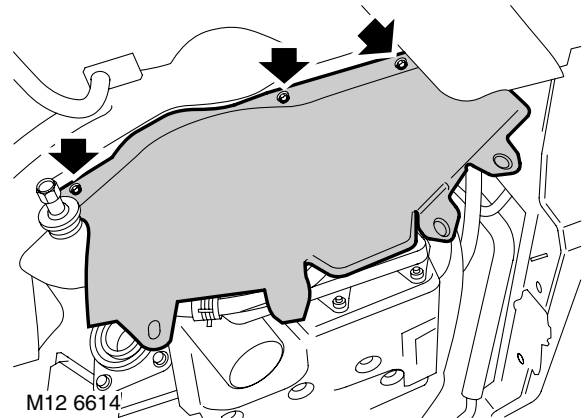

11. Remove **LRT-12-198** alignment pins and fit new camshaft gear retaining bolts.
12. Tighten camshaft gear bolts to:
  - Stage 1 - 27 Nm (20 lbf.ft)
  - Stage 2 - Further 90°
13. Remove **LRT-12-175** from camshaft gears.
14. Remove **LRT-12-197** from front end of exhaust camshaft.
15. Clean LH exhaust camshaft cap seal recess and fit new cap seal.
16. Remove timing pin **LRT-12-232** from lower crankcase.
17. Fit splash shield and secure with bolts.
18. Fit RH road wheel and tighten nuts to 115 Nm (85 lbf.ft).
19. Fit LH rear timing belt cover.  
👉 **ENGINE - K SERIES KV6, REPAIRS, Camshaft timing belt cover - LH rear.**
20. Fit underbelly panel.  
👉 **EXTERIOR FITTINGS, REPAIRS, Panel - underbelly.**
21. Connect battery earth lead.

4. Remove 3 bolts securing RH splash shield to body and remove shield.
5. Remove RH rear timing belt cover.  
👉 **ENGINE - K SERIES KV6, REPAIRS, Camshaft timing belt cover - RH rear.**

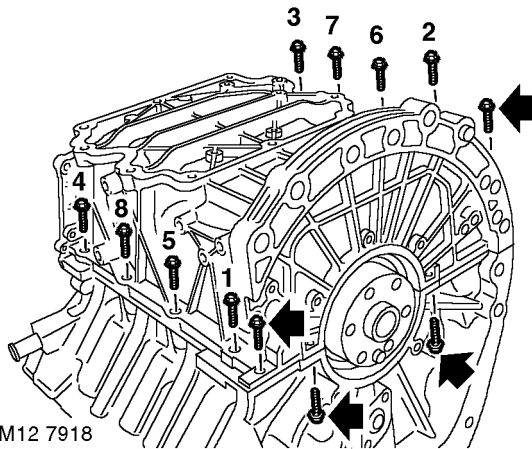

M12 7918

2. Using sequence shown, remove 8 M8 bolts securing lower crankcase to cylinder block.
3. Remove remaining M8 bolt and 2 M6 bolts securing lower crankcase to cylinder block.
4. Remove lower crankcase.

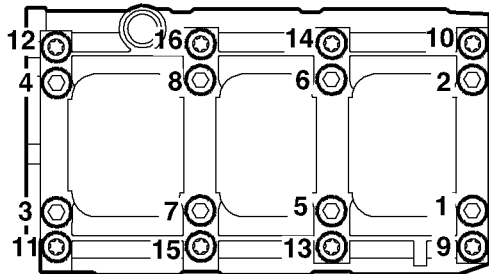

M12 7882

5. Using sequence shown, remove and discard 16 bolts securing bearing ladder to cylinder block.  
*NOTE: Short length bolts are fitted to the outer edge of the bearing ladder.*
6. Release bearing ladder from dowels and remove from cylinder block.

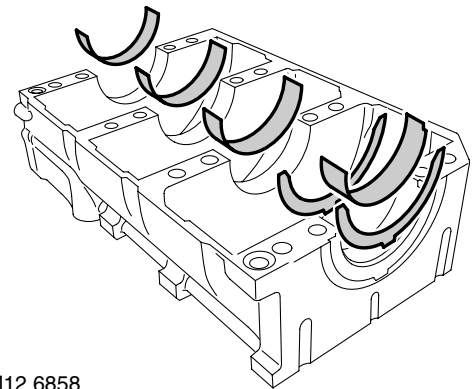

M12 6858

7. Remove main bearing shells and 2 thrust washer halves from bearing ladder, keep main bearing shells in fitted order; discard thrust washers.

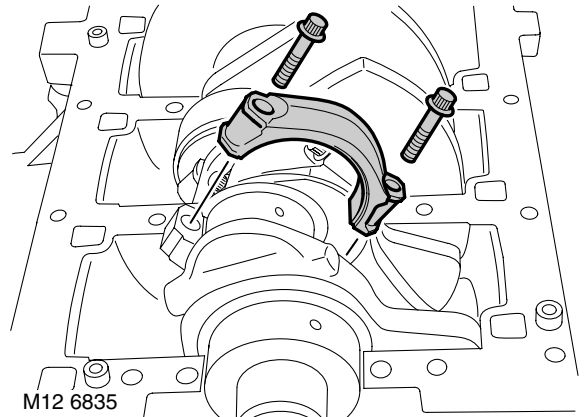

M12 6835

8. Temporarily fit crankshaft pulley bolt.
9. Remove 4 dowel bolts and remove big end bearing caps from No 1 and No 2 connecting rods. Keep bearing caps in order.

*NOTE: Number stamped below bearing cap bolt is bearing bore size code. Number stamped on connecting rod is cylinder number and letter is weight code.*

**CAUTION: Do not remove cylinder clamps LRT-12-144 unless pistons and connecting rods are to be removed.**

10. Release connecting rods from crankshaft.
11. Remove bearing shells from connecting rod and cap.
12. Rotate crankshaft using pulley bolt, remove bolts securing remaining connecting rod bearing caps. Remove bearing caps and bearing shells from caps. Keep bearing caps in their fitted order.

## ENGINE - K SERIES KV6

17. Position injector protection cover - if fitted to RH fuel rail and secure injector harness to protection cover or fuel rail with clips.
18. Fit bolts securing fuel rail to inlet manifolds and tighten to 9 Nm (7 lbf.ft).
19. Connect coolant bleed hose to inlet manifold and secure with clip.
20. Position ignition coils to LH inlet manifold.
21. Position earth lead, fit nuts and bolts securing ignition coils to LH inlet manifold and tighten to 9 Nm (7 lbf.ft).
22. Connect multiplugs to plug top coils and secure with locking clips.
23. Clean camshaft timing belt cover backplate bolts and apply Loctite 242 to the first 3 threads.
24. Position backplate, fit and tighten bolts to 9 Nm (7 lbf.ft).
25. Fit new camshaft timing belt.  
👉 **ENGINE - K SERIES KV6, OVERHAUL, Camshaft timing belt.**
26. Clean exhaust manifold and mating face on cylinder head.

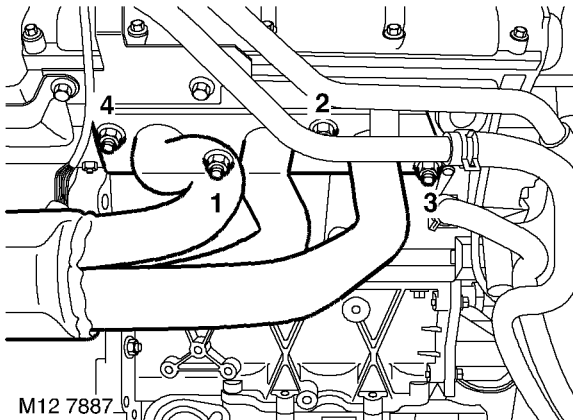

27. Fit new exhaust manifold gasket. Position exhaust manifold, fit nuts and using sequence shown, tighten to 45 Nm (33 lbf.ft).
28. Connect RH HO2S multiplug, secure multiplug in coolant rail bracket.

## Cylinder head - decarbonise

🔑 12.29.19

### Remove

1. Remove cylinder head gaskets.  
👉 **ENGINE - K SERIES KV6, OVERHAUL, Cylinder head gasket - LH.**  
👉 **ENGINE - K SERIES KV6, OVERHAUL, Cylinder head gasket - RH.**

### Disassembly

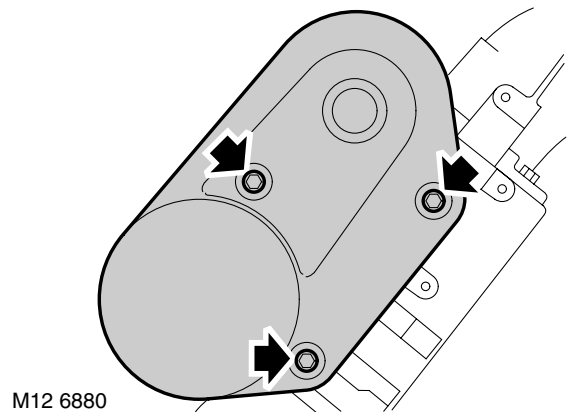

1. **LH Cylinder head:** Remove 3 bolts securing LH rear timing belt cover and remove cover.

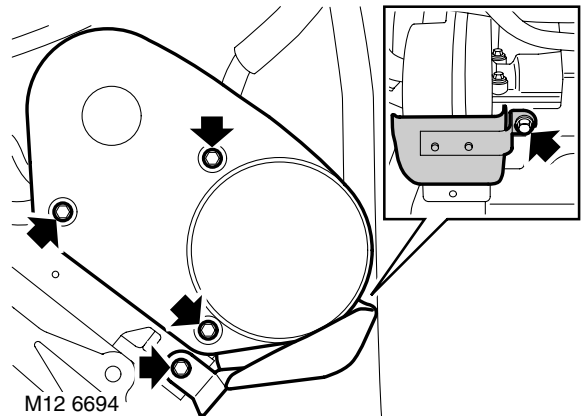

2. **RH Cylinder head:** Remove 2 bolts securing RH rear timing belt cover heat shield to cylinder head.
3. **RH Cylinder head:** Remove 3 bolts securing RH rear timing belt cover; remove cover.



## Inspect

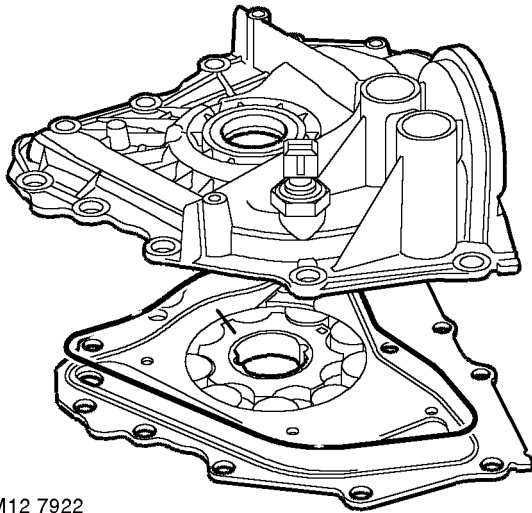

M12 7922

3. Carefully remove cover plate from oil pump body taking care to ensure that rotors are retained in pump body.  
*Note: Cover plate is dowel located.*
4. Remove and discard cover plate sealing ring.
5. Make suitable alignment marks between inner and outer rotors and pump body.
6. Remove inner and outer rotors.
7. Clean inner and outer rotors and rotor housing.
8. Fit inner and outer rotors ensuring that reference marks are aligned.

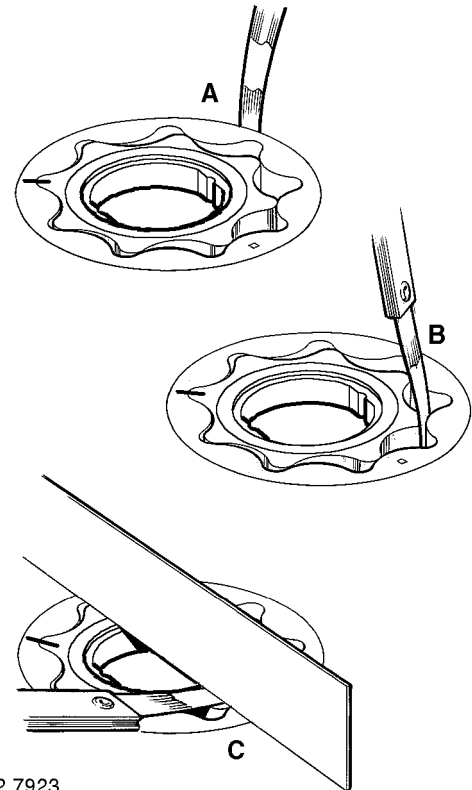

M12 7923

1. Check rotor clearances:
  - Outer rotor to body = 0.13 - 0.23 mm (0.0051 - 0.0091 in)
  - Inner rotor tip = 0.05 - 0.13 mm (0.002 - 0.005 in)
  - Inner and outer rotor end-float = 0.04 - 0.09 mm (0.0016 - 0.0035 in)
2. Renew oil pump as an assembly if clearances are excessive.

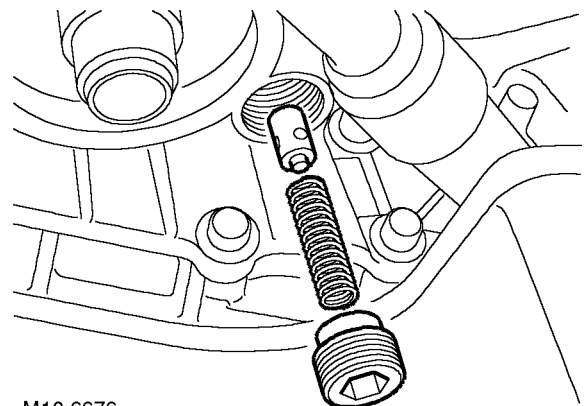

M12 6676

3. Remove oil pressure relief valve plug.  
*Note: If a hexagonal plug and sealing washer are fitted, discard washer.*





## Filter - fuel leak detection pump - KV6 - NAS

🔑 17.45.42

### Remove

1. Disconnect battery earth lead.
2. Remove RH rear wheel arch liner.  
 📌 **EXTERIOR FITTINGS, REPAIRS, Liner - rear wheel arch.**

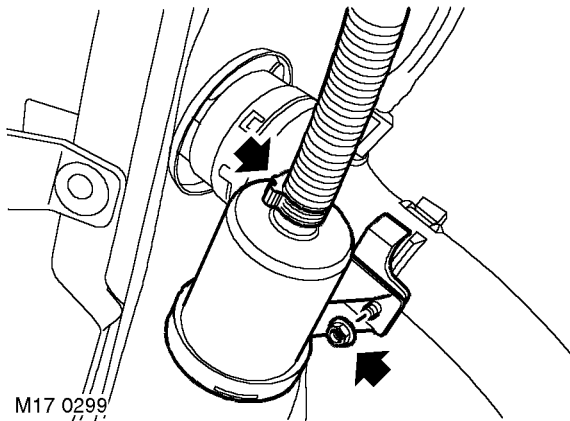

3. Remove nut and release filter from bracket.
4. Release clip and remove filter from pipe.

**CAUTION:** Before disconnecting or removing components, ensure the immediate area around joint faces and connections are clean. Plug open connections to prevent contamination.

### Refit

1. Fit filter to pipe and secure with clip.
2. Fit filter to bracket and tighten nut to 3 Nm (2.2 lbf.ft).
3. Fit wheel arch liner.  
 📌 **EXTERIOR FITTINGS, REPAIRS, Liner - rear wheel arch.**
4. Connect battery earth lead.

## Catalytic converter - RH - KV6 - NAS

🔑 17.50.01

### Remove

1. Position vehicle on 4 post ramp.
2. Disconnect battery earth lead.
3. Remove engine acoustic cover.  
 📌 **ENGINE - K SERIES KV6, REPAIRS, Cover - engine acoustic.**

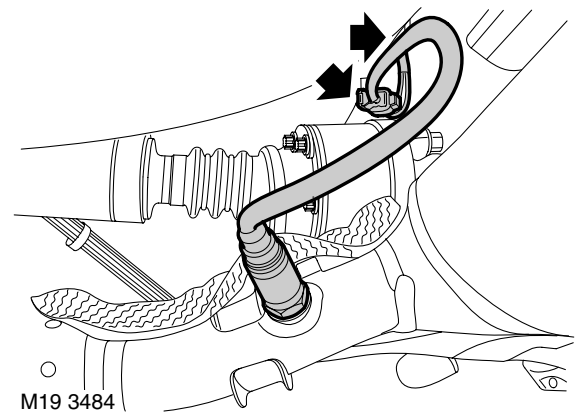

4. Release pre catalyst H<sub>2</sub>S harness from clips.
5. Release and disconnect HO<sub>2</sub>S multiplug.
6. Remove intermediate pipe and silencer.  
 📌 **MANIFOLDS & EXHAUST SYSTEMS - K SERIES KV6, REPAIRS, Intermediate pipe - NAS.**

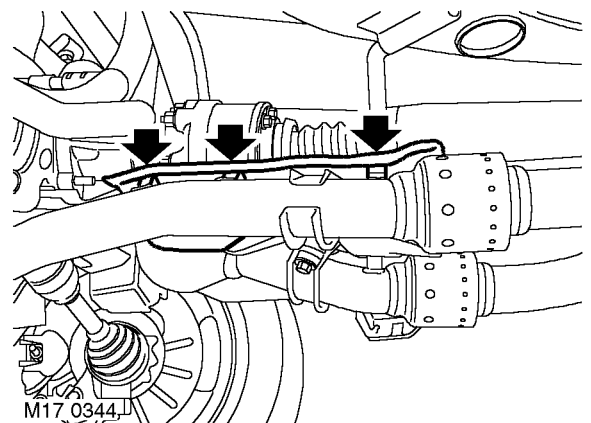

7. Remove 3 bolts and remove LH heat shield.

# ENGINE MANAGEMENT SYSTEM - MEMS

## Sensor - camshaft position (CMP)

🔑 18.30.24

### Remove

1. Disconnect battery earth lead.

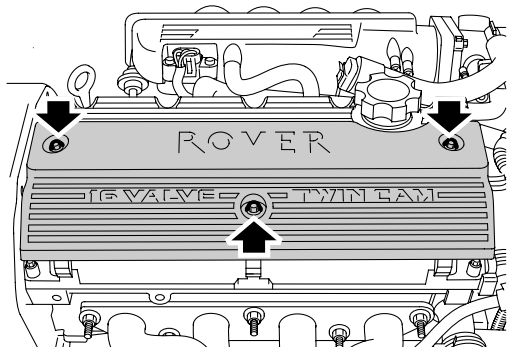

M18 0688

2. Remove three bolts securing coil cover to engine and remove coil cover.

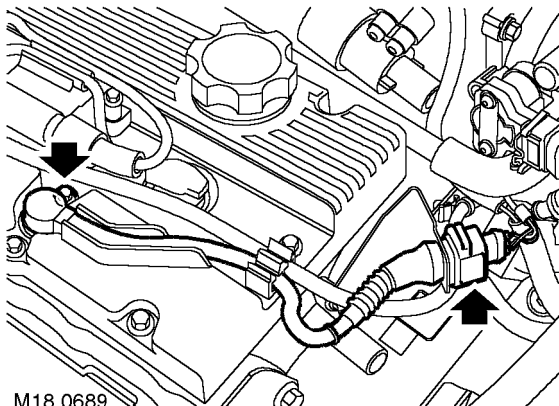

M18 0689

3. Release CMP sensor multiplug from bracket and disconnect multiplug.
4. Release sensor cable from clip.
5. Remove bolt securing CMP sensor and remove sensor.

### Refit

1. Clean CMP sensor and mating face.
2. Fit CMP sensor, fit bolt and tighten to 10 Nm (8 LBF.FT).
3. Connect CMP sensor multiplug and secure to bracket.
4. Position coil cover, fit bolts and tighten to 10 Nm (8 LBF.FT).
5. Connect battery earth lead.

## Sensor - manifold absolute pressure (MAP)

🔑 18.30.56

### Remove

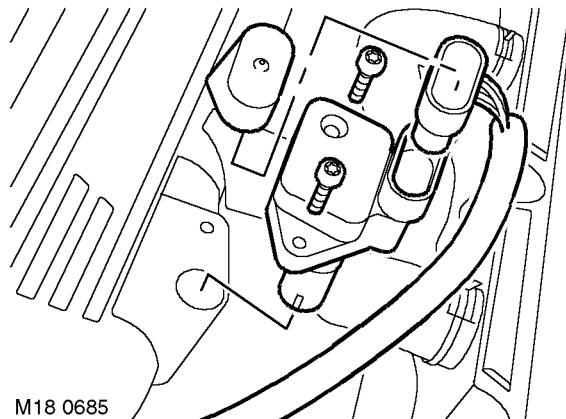

M18 0685

1. Remove cover and disconnect MAP sensor multiplug.
2. Remove 2 Torx screws securing MAP sensor to inlet manifold.
3. Remove MAP sensor from manifold.

### Refit

1. Clean MAP sensor and manifold mating faces.
2. Fit MAP sensor to inlet manifold and tighten Torx screws.
3. Connect MAP sensor multiplug.
4. Fit MAP sensor multiplug cover.



**Sensor - knock (KS)**

🔑 18.30.28

**Remove**

1. Disconnect battery earth lead.
2. Remove LH inlet manifold.  
 📖 **MANIFOLDS & EXHAUST SYSTEMS**  
**- K SERIES KV6, REPAIRS, Gasket - inlet manifold - LH.**

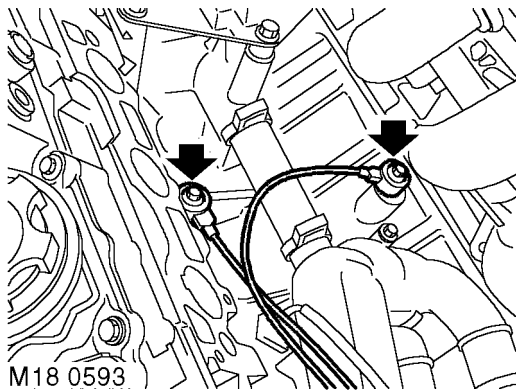

3. Disconnect KS multiplug.
4. Note the routing of each KS harness.
5. Remove 2 bolts securing KS to cylinder block and remove sensors.

**Refit**

1. Clean KS and mating faces on cylinder block.
2. Position KS, ensure that harnesses are correctly routed, fit and tighten bolts to 25 Nm (18 lbf.ft).
3. Connect KS multiplug.
4. Fit LH inlet manifold.  
 📖 **MANIFOLDS & EXHAUST SYSTEMS**  
**- K SERIES KV6, REPAIRS, Gasket - inlet manifold - LH.**
5. Connect battery earth lead.

**Sensor - throttle pedal position - Non NAS**

🔑 18.30.36

**Remove**

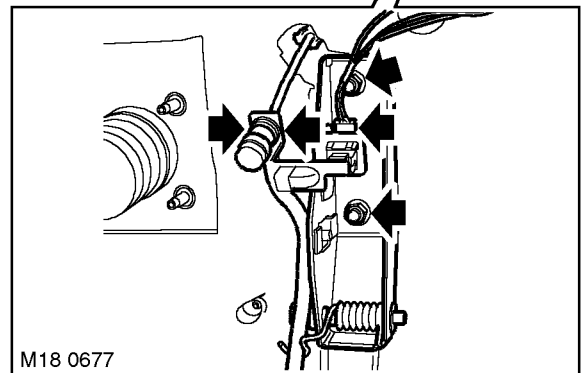
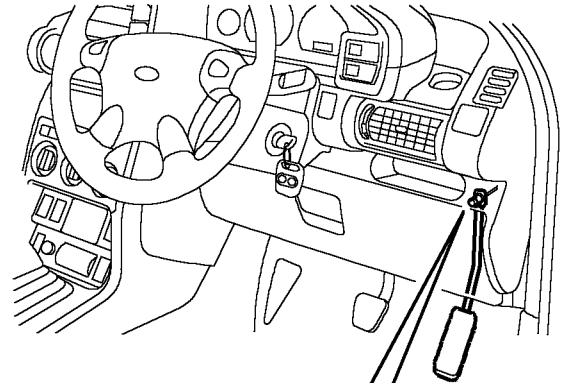

1. Remove 2 nuts securing throttle pedal assembly to bulkhead.
2. Release clip securing throttle inner cable to throttle pedal and disconnect inner cable from pedal.
3. Disconnect multiplug from throttle pedal sensor.
4. Remove throttle pedal assembly from vehicle.

## FUEL DELIVERY SYSTEM - DIESEL

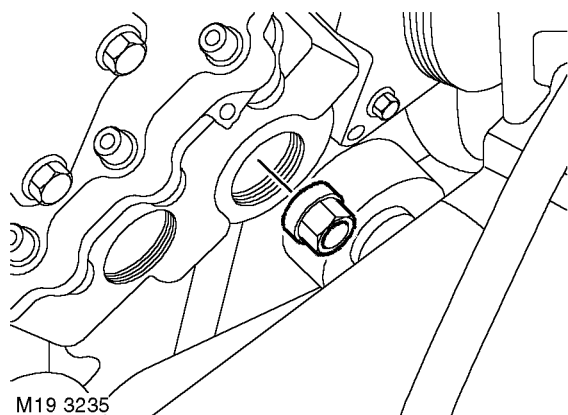

7. Remove fuel pump sprocket nut.

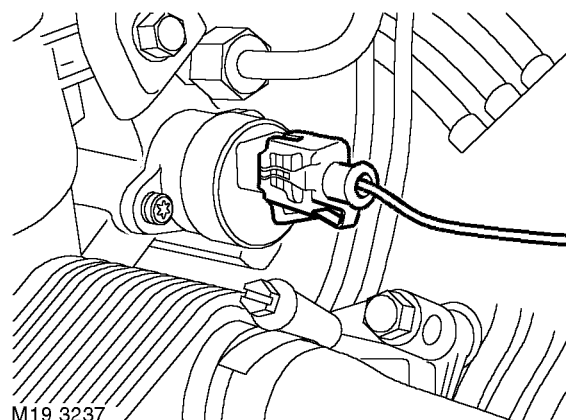

10. Disconnect multiplug from fuel pump.

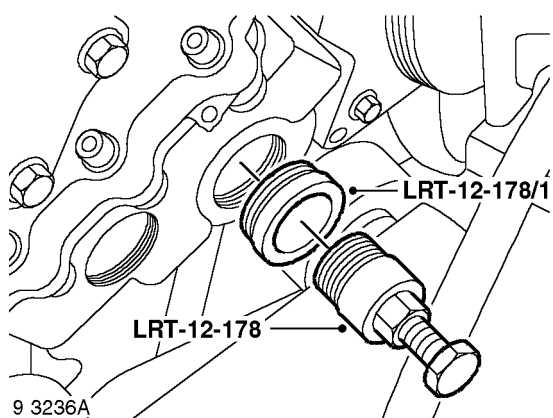

8. Fit LRT-12-178/1 into timing cover.

9. Fit LRT-12-178 to fuel pump sprocket and tighten centre screw to release sprocket from fuel pump.

**CAUTION: Do not remove puller from sprocket until fuel pump is fitted.**

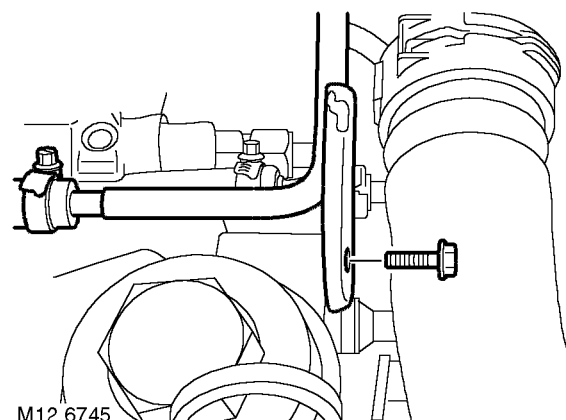

11. Remove bolt, fuel pipe bracket to oil filter housing.

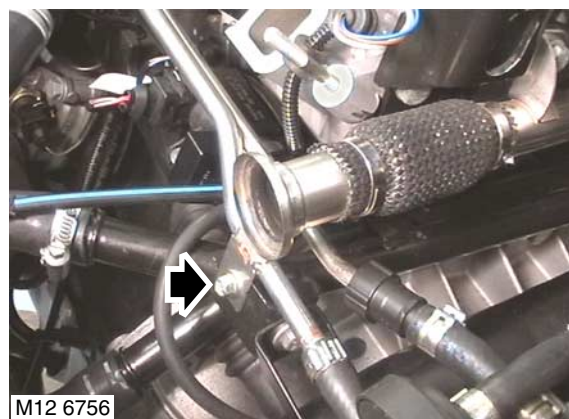

12. Remove bolt fuel rail to coolant rail.



**Lift pump - fuel**

🔑 19.45.09

**Remove**

1. Disconnect battery earth lead.

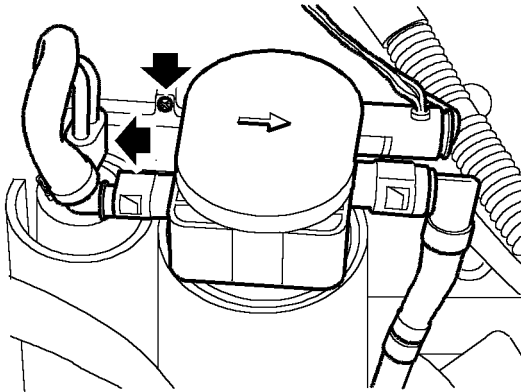

M19 3220

2. Remove screw securing fuel pump housing to bracket.

**WARNING: Fuel vapour is highly flammable and in confined spaces is also explosive and toxic. Always have a fire extinguisher containing foam, CO<sub>2</sub>, gas or powder close at hand when handling or draining fuel.**

3. Lift and tilt fuel pump housing away from bracket.
4. Disconnect multiplug from fuel pump.
5. Position absorbent cloth to collect fuel spillage.

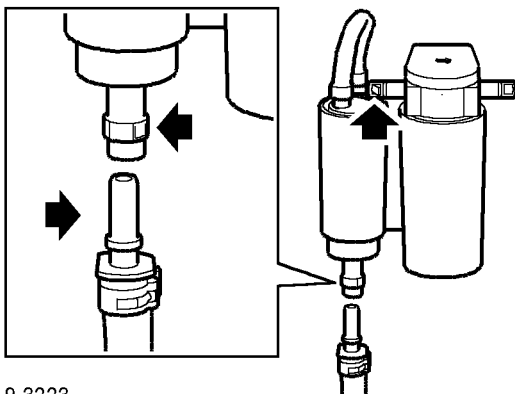

M19 3223

6. Disconnect quick release fuel hose connectors from fuel pump and filter.

**CAUTION: Always fit plugs to open connections to prevent contamination.**

7. Remove fuel pump.

8. Release retaining clips and remove hoses from fuel pump.

**Refit**

1. Connect hoses to fuel pump and secure with retaining clips.
2. Fit fuel pump to housing.
3. Connect quick release fuel hose connectors to pump and filter.
4. Connect multiplug to fuel pump.
5. Fit fuel pump housing to bracket and secure with screw.
6. Remove absorbent cloth.
7. Connect battery earth lead.

# FUEL DELIVERY SYSTEM - PETROL

## Throttle cable - check and adjust - K1.8

🔑 19.20.05

### Check

1. Before adjusting cable, ensure that cable is correctly routed and located.

### Adjust

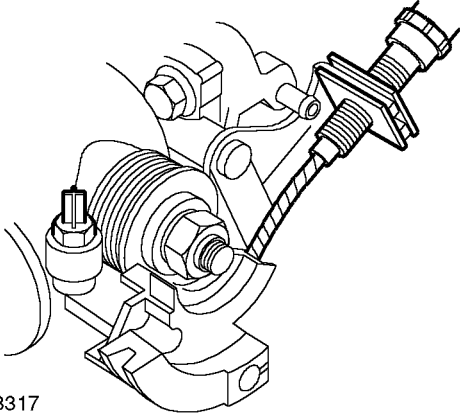

M19 3317

1. Release cable adjusting nut from abutment bracket.
2. Hold throttle cam in fully closed position.
3. Rotate adjusting nut until all slack is taken out of inner cable and nut is in contact with rear face of abutment bracket. Ensure throttle does not open.
4. Fit throttle cable adjusting nut in abutment bracket.
5. Operate throttle pedal and ensure that full throttle pedal movement is available.

## Fuel system - depressurise - KV6 - Non NAS

🔑 19.50.02

### Check

1. Remove acoustic cover.  
👉 **ENGINE - K SERIES KV6, REPAIRS, Cover - engine acoustic.**
2. Position absorbent cloth around fuel feed pipe connection to collect spillage.

**WARNING: The spilling of fuel is unavoidable during this operation. Ensure that all necessary precautions are taken to prevent fire and explosion.**

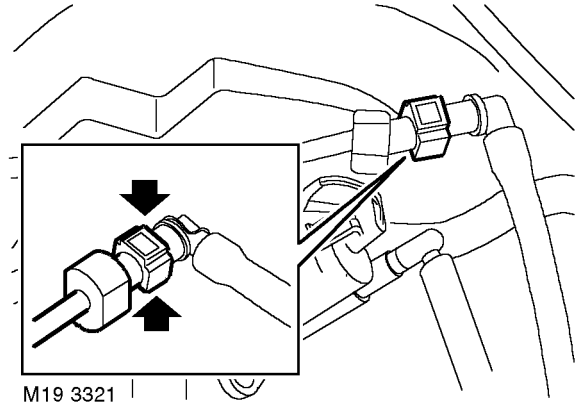

M19 3321

3. Pull back cover from hose connector and carefully release connector.  
**WARNING: Depressurise the system before disconnecting any components. Fuel pressure will be present in the system even if the ignition has been switched off for some time.**
4. Secure connector once pressure has been relieved.
5. Fit acoustic cover.  
👉 **ENGINE - K SERIES KV6, REPAIRS, Cover - engine acoustic.**



**Sensor - heated oxygen (HO2S) - front - K1.8**

19.22.16

**Remove**

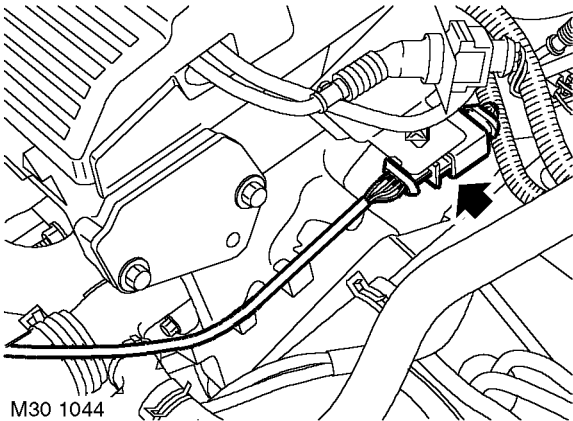

1. Release and disconnect HO2S multiplug.

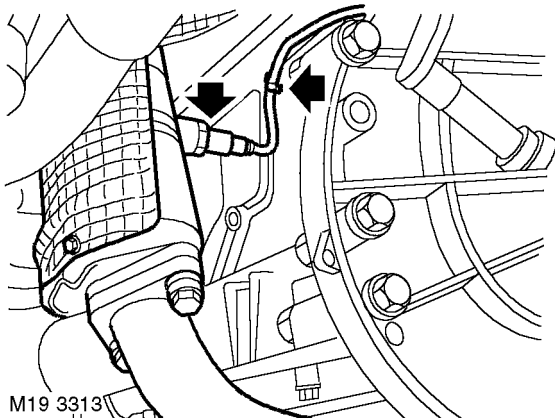

2. Release HO2S harness from clip on cylinder block.
3. Using a 22 mm crowsfoot spanner, remove HO2S.

**Refit**

1. Clean HO2S, sealing washer and mating faces.
2. Fit HO2S and tighten to 55 Nm (41 lbf.ft).
3. Connect HO2S multiplug and secure to support bracket.
4. Secure HO2S harness to cylinder block clip.

**Sensor - heated oxygen (HO2S) - pre-catalyst - RH - KV6 - Non NAS**

19.22.17

**Remove**

1. Raise front of vehicle.  
*WARNING: Do not work on or under a vehicle supported only by a jack. Always support the vehicle on safety stands.*
2. Remove LH front road wheel.

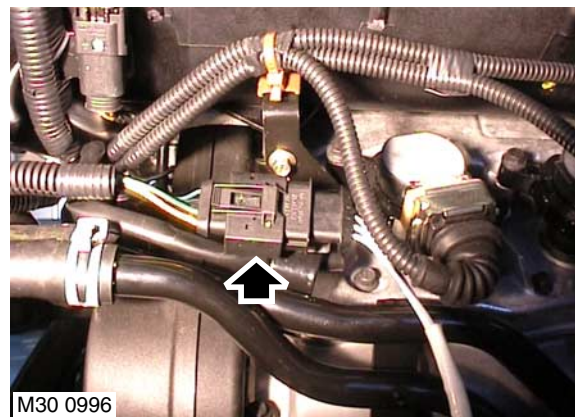

3. Release RH HO2S multiplug from coolant rail bracket and disconnect multiplug.

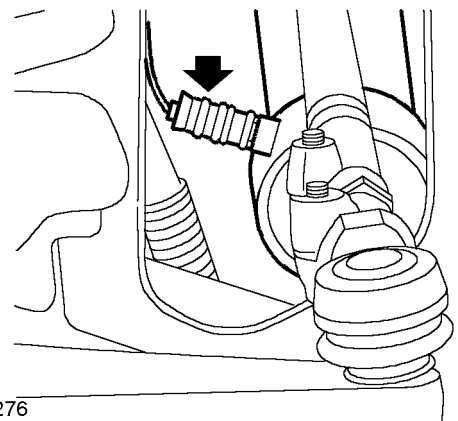

4. Remove HO2S from RH exhaust manifold.

**Refit**

1. Clean HO2S and exhaust manifold mating face.
2. Fit HO2S and tighten to 55 Nm (41 lbf.ft).
3. Connect RH HO2S multiplug, secure multiplug in coolant rail bracket.

## FUEL DELIVERY SYSTEM - PETROL

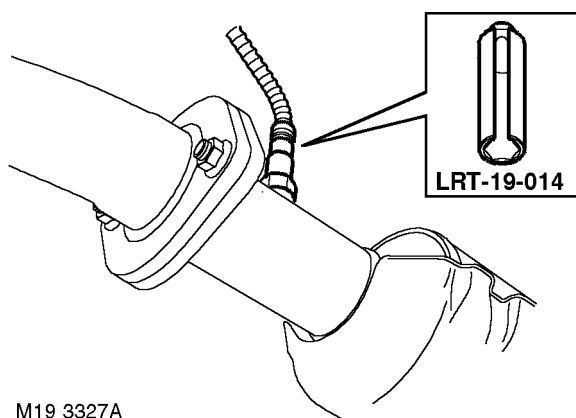

M19 3327A

5. Remove HO2S.

### Refit

1. Clean HO2S and mating face.
2. Fit HO2S and tighten to 55 Nm (41 lbf.ft) using tool **LRT-19-014**.
3. Feed HO2S harness through grommet aperture and secure grommet.
4. Connect HO2S multiplug.
5. Fit gaiter to centre console and secure with clips.
6. Remove stand(s) and lower vehicle.

## Sensor - heated oxygen (HO2S) - post catalyst - RH - KV6 - NAS

19.22.72

### Remove

1. Disconnect battery earth lead.
2. Raise vehicle on 4 post ramp.
3. Release HO2S harness from clips.



M19 3505

4. Release and disconnect HO2S multiplug.

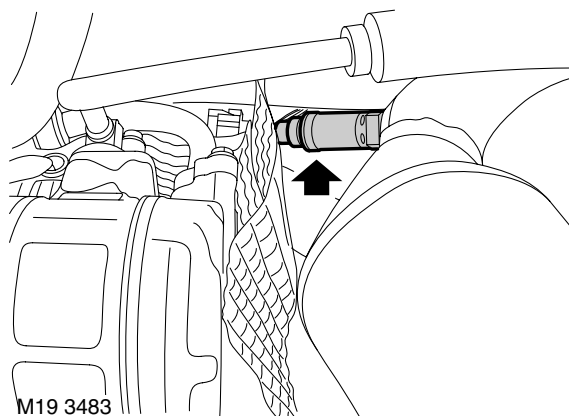

M19 3483

5. Remove HO2S.

### Refit

1. Clean HO2S and mating face.
2. Fit HO2S and tighten to 55 Nm (40 lbf.ft).
3. Connect HO2S multiplug and fit to bracket.
4. Fit harness into clips.
5. Lower ramp.
6. Connect battery earth lead.

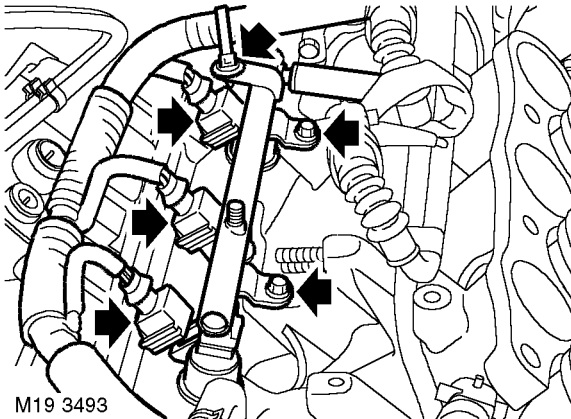

M19 3493

12. Remove 2 bolts securing fuel rail to LH inlet manifold.
13. Release clips and disconnect injector multiplugs.

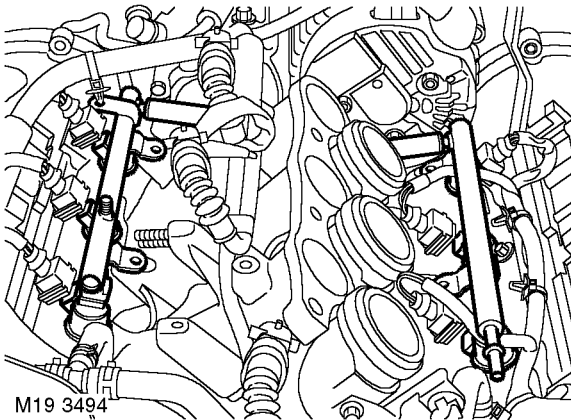

M19 3494

14. Release injectors from manifolds, raise fuel rail assembly, disconnect 4 clips securing injector harness to fuel rails and move harness aside.

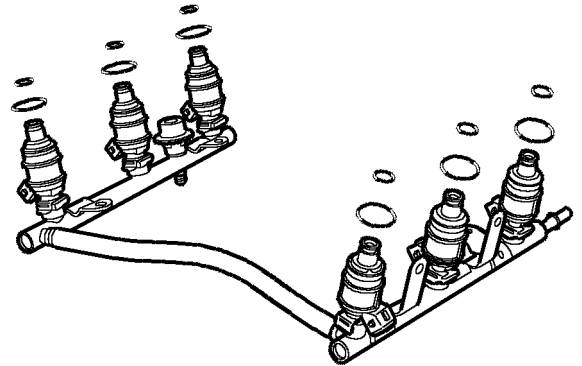

M19 3495

15. Remove fuel rail and discard 'O' rings  
**CAUTION: Always fit plugs to open connections to prevent contamination.**

**Refit**

1. Lubricate new 'O' rings with castor oil and fit to injectors.
2. Remove plugs from inlet manifolds.
3. Position injector harness to fuel rail and secure with clips.
4. Position injectors and fuel rail to inlet manifolds.
5. Connect multiplugs to injectors.
6. Fit and tighten 4 bolts securing fuel rail to inlet manifold to 8 Nm (6 lbf.ft).
7. Position ignition coils to LH inlet manifold.
8. Position earth lead, fit nuts and bolts securing ignition coils to LH inlet manifold and tighten to 9 Nm (7 lbf.ft).
9. Position alternator and secure with nuts and bolts, tighten to 45 Nm (33 lbf.ft).
10. Using a 3/8" square drive socket bar, raise ancillary drive belt tensioner and fit drive belt to pulleys.
11. Fit underbelly panel.  
 **EXTERIOR FITTINGS, REPAIRS, Panel - underbelly.**
12. Fit inlet manifold chamber.  
 **MANIFOLDS & EXHAUST SYSTEMS - K SERIES KV6, REPAIRS, Seals - inlet manifold chamber.**
13. Connect battery earth lead.

CLICK HERE TO **DOWNLOAD** THE COMPLETE MANUAL

- Thank you very much for reading the preview of the manual.
- You can download the complete manual from: [www.heydownloads.com](http://www.heydownloads.com) by clicking the link below



- Please note: If there is no response to CLICKING the link, please download this PDF first and then click on it.

CLICK HERE TO **DOWNLOAD** THE COMPLETE MANUAL

# COOLING SYSTEM - TD4

## Coolant pump and thermostat

🔑 26.50.01

### Remove

1. Disconnect battery earth lead.
2. Remove camshaft cover gasket.  
👉 **ENGINE - Td4, REPAIRS, Gasket - camshaft cover.**
3. Drain cooling system.  
👉 **COOLING SYSTEM - Td4, ADJUSTMENTS, Coolant - drain and refill.**
4. Remove RH front road wheel.
5. Remove ancillary drive belt.  
👉 **CHARGING AND STARTING, REPAIRS, Ancillary drive belt - Td4.**
6. Remove engine lower steady.  
👉 **ENGINE - Td4, REPAIRS, Engine steady - lower.**
7. Remove hydramount.  
👉 **ENGINE - Td4, REPAIRS, Hydramount - engine - RH.**

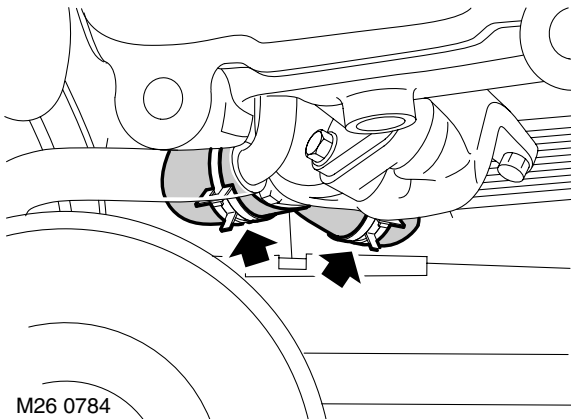

8. Release 2 clips securing hose to coolant rail and thermostat housing.
9. Release and remove hose.

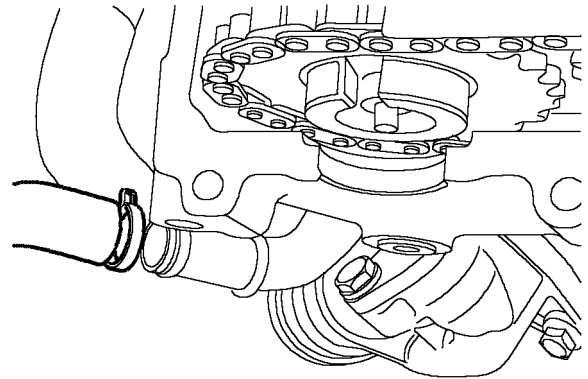

10. Release clip and disconnect expansion tank hose from coolant rail.

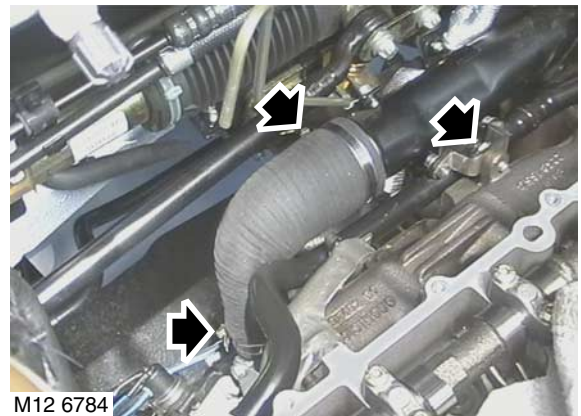

11. Loosen clips and remove turbocharger outlet hose.
12. Remove bolt coolant rail to exhaust manifold.

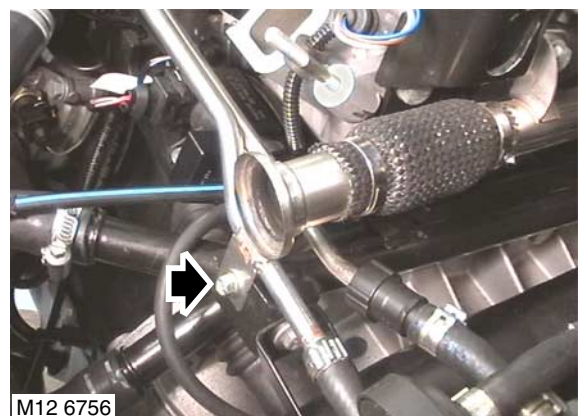

13. Remove bolt, fuel rail to coolant rail.



## Coolant - drain and refill

🔑 26.10.01

### Drain

1. Remove engine acoustic cover.  
 📌 **ENGINE - K SERIES KV6, REPAIRS, Cover - engine acoustic.**
2. Visually check engine and cooling system for signs of coolant leaks.  
**WARNING: Since injury such as scalding could be caused by escaping steam or coolant, do not remove the filler cap from the coolant expansion tank while the system is hot.**
3. Examine hoses for signs of cracking, distortion and security of connections.
4. Remove expansion tank filler cap.
5. Remove underbelly panel.  
 📌 **EXTERIOR FITTINGS, REPAIRS, Panel - underbelly.**
6. Position container to collect coolant.

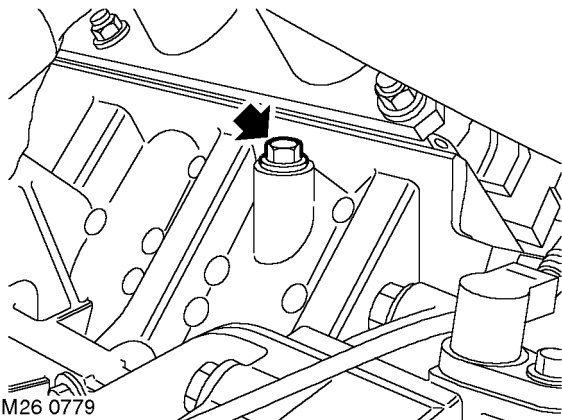

7. Remove cylinder block drain plug.

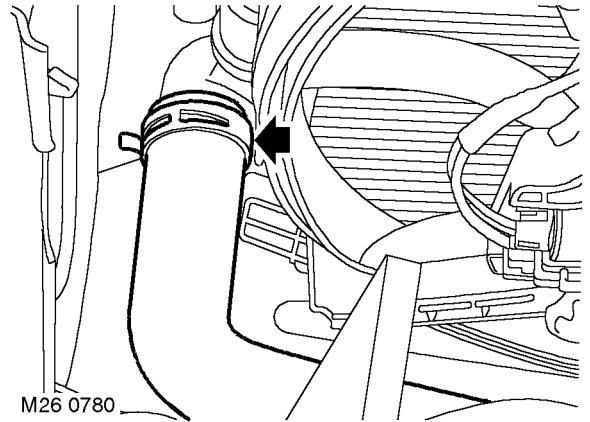

8. Release clip and remove bottom hose from radiator.
9. Allow cooling system to drain.

### Refill

1. Flush system with water under low pressure.  
**Do not use water under high pressure as it could damage the radiator.**
2. Clean cylinder block drain plug and apply Loctite 242 to first 3 threads.
3. Fit cylinder block drain plug and tighten to 20 Nm (15 lbf.ft).
4. Fit bottom hose to radiator and secure with clip.
5. Prepare coolant to required concentration.  
 📌 **CAPACITIES, FLUIDS AND LUBRICANTS, Fluids.**

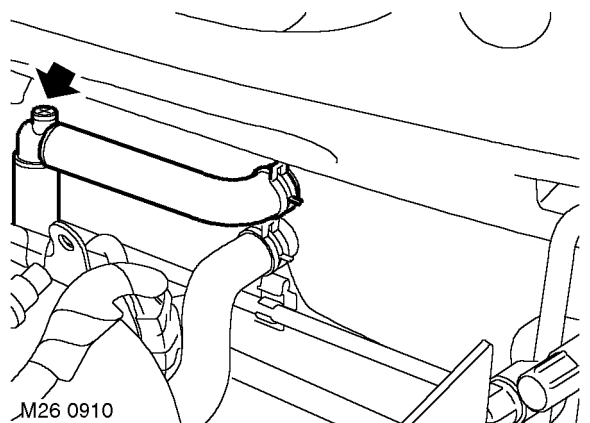

6. Remove bleed screw from heater return hose.
7. Slowly fill the system through the coolant expansion tank until a steady flow of coolant is emitted from the bleed hole.
8. Fit and close bleed screw in heater return hose.
9. Continue to fill system through the expansion tank until coolant reaches to the base of the expansion tank bleed hose.
10. Fit expansion tank filler cap.

## Gasket- exhaust manifold - manual transmission

🔑 30.15.12

### Remove

1. Disconnect battery earth lead.
2. Drain cooling system.  
👉 **COOLING SYSTEM - Td4, ADJUSTMENTS, Coolant - drain and refill.**
3. Remove camshaft cover gasket.  
👉 **ENGINE - Td4, REPAIRS, Gasket - camshaft cover.**

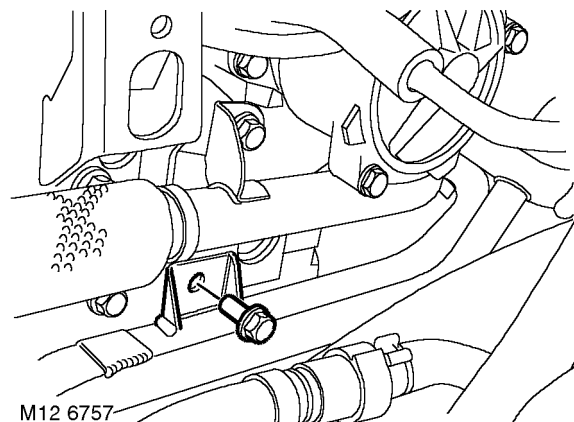

6. Remove bolt, coolant rail to cylinder head.

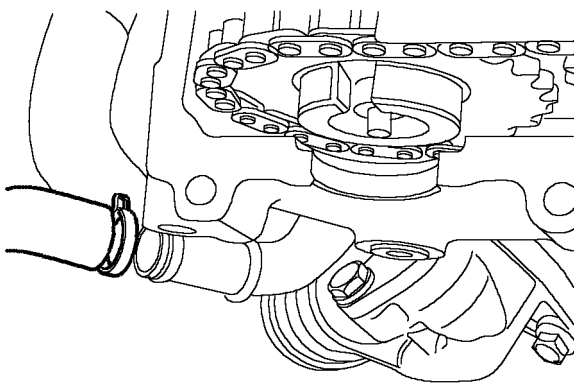

4. Release clip and disconnect expansion tank hose from coolant rail.

7. Remove bolt, coolant rail to exhaust manifold.
8. Loosen clips and remove turbocharger outlet hose.

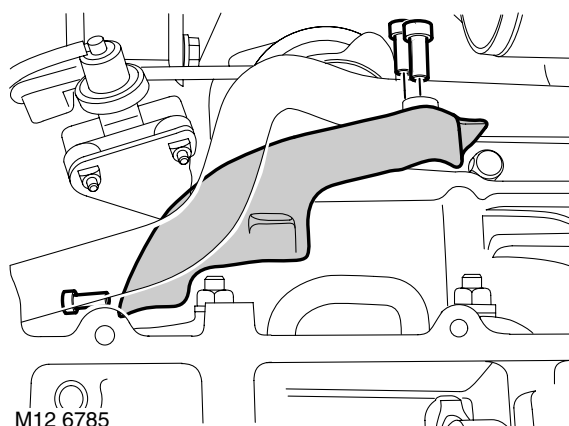
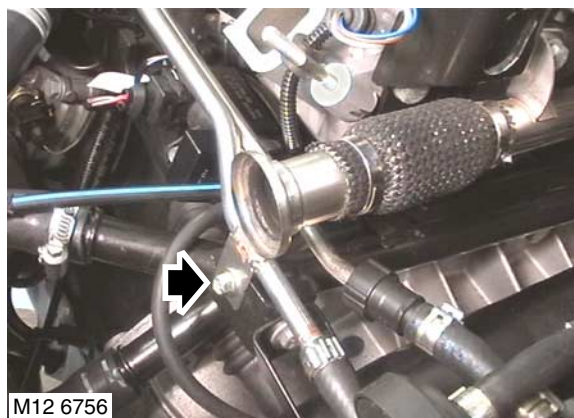

5. Remove bolt, fuel rail to coolant rail.

9. Remove 3 Allen screws, heat shield to coolant rail.



**Heat shield - exhaust manifold - with A/C**

🔑 30.15.09

**Remove**

1. Disconnect battery earth lead.
2. Turn steering on RH lock.

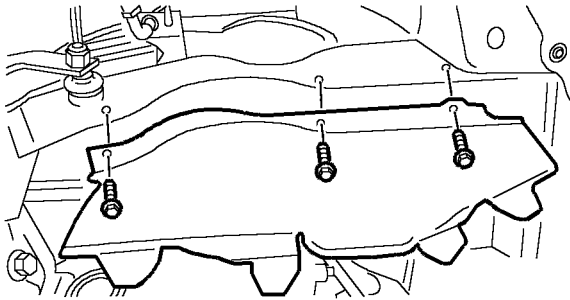

M12 6977

3. Remove 3 bolts securing RH splash shield to body and remove shield.

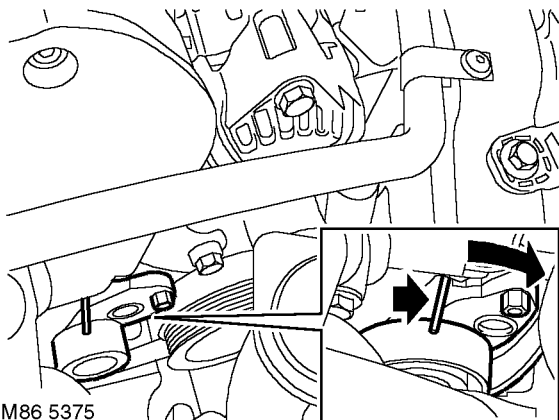

M86 5375

4. Fit a 13 mm spanner to hexagon on belt tensioner and rotate fully clockwise to release tension from drive belt.
5. To hold tensioner in this position, fit a suitable pin, not exceeding 3 mm diameter, through centre of hexagon into tensioner backplate.
6. Release auxiliary drive belt from alternator pulley.



M30 1048

7. Remove top bolt securing alternator and loosen lower bolt.
8. Position alternator forward to clear heat shield.

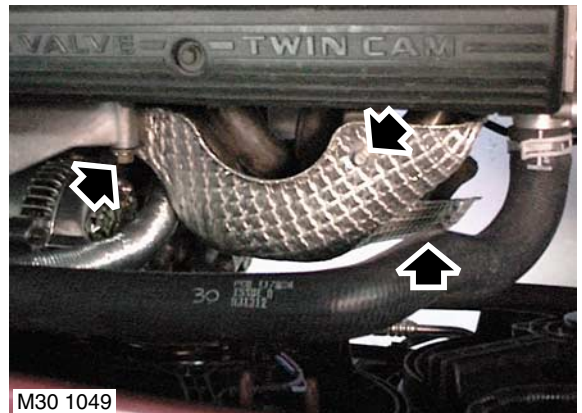

M30 1049

9. Remove nut and 2 bolts securing heat shield.
10. Remove heat shield.

**Refit**

1. Fit heat shield.
2. Locate heat shield to alternator bracket stud, fit nut and bolts. Tighten nut to 25 Nm (18 lbf.ft) and bolts to 10 Nm (7.5 lbf.ft).
3. Align alternator to bracket and fit bolt.
4. Tighten both alternator bolts to 45 Nm (33 lbf.ft).
5. Locate drive belt to pulleys, remove locking pin and release drive belt tensioner.
6. Ensure auxiliary drive belt is correctly located on all pulleys.
7. Fit splash shield and secure with bolts.
8. Straighten steering.
9. Connect battery earth lead.

## Gasket - exhaust manifold - RH - Non NAS

🔑 30.15.16

### Remove

1. Disconnect battery earth lead.

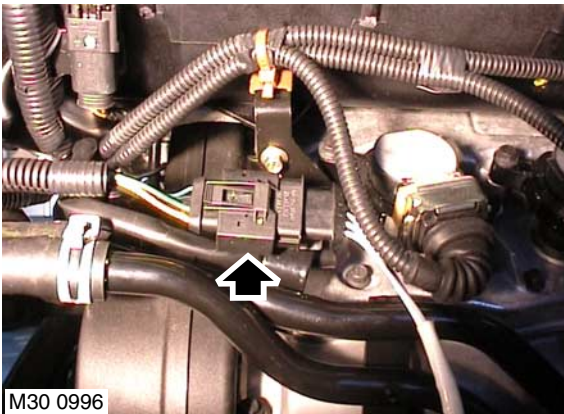

2. Release RH HO2S multiplug from coolant rail bracket and disconnect multiplug.

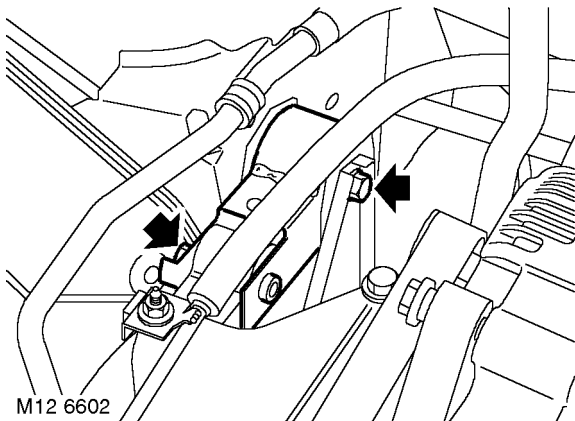

3. Remove bolt securing upper RH engine steady to top arm.
4. Loosen bolt securing upper RH engine steady to body, pivot engine steady away from top arm.
5. Raise vehicle on a ramp.
6. Remove underbelly panel.
  - 👉 EXTERIOR FITTINGS, REPAIRS, Panel - underbelly.
7. Remove exhaust front pipe.
  - 👉 MANIFOLDS & EXHAUST SYSTEMS - K SERIES KV6, REPAIRS, Front pipe - Non NAS.

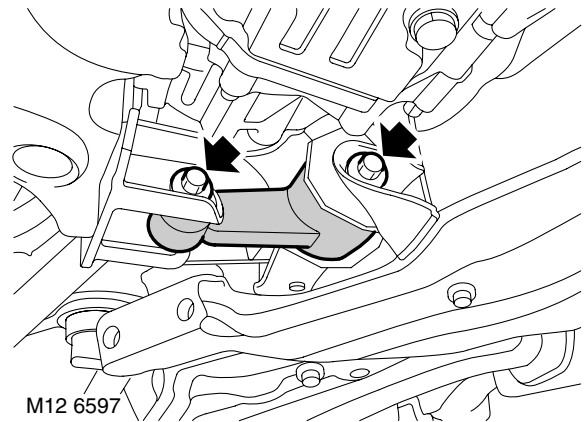

8. Remove bolt securing lower engine steady to sump mounting bracket.
9. Loosen bolt securing lower engine steady to subframe, pivot steady away from sump mounting bracket.
10. Remove cable tie and release gear selector cable from clip on body.

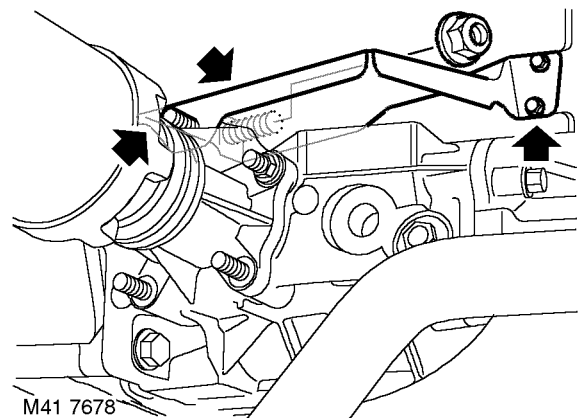

11. Remove 2 bolts securing IRD heat shield to lower engine steady mounting bracket.
12. Remove nut securing heat shield to IRD pinion housing.
13. Remove nut securing heat shield to IRD housing and remove heat shield.



**Gasket(s) - manifold chamber**

🔑 30.15.37.01

**Remove**

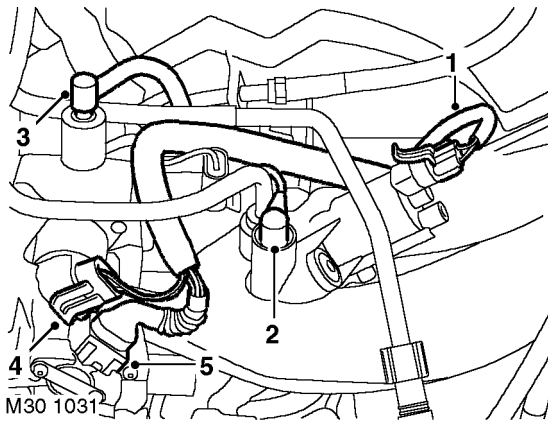

1. Disconnect multiplug from purge control valve.
2. Disconnect small vacuum hose from purge control valve.
3. Depress locking collar and release vacuum hose from IACV housing .
4. Disconnect multiplug from IACV.
5. Disconnect multiplug from TP sensor.

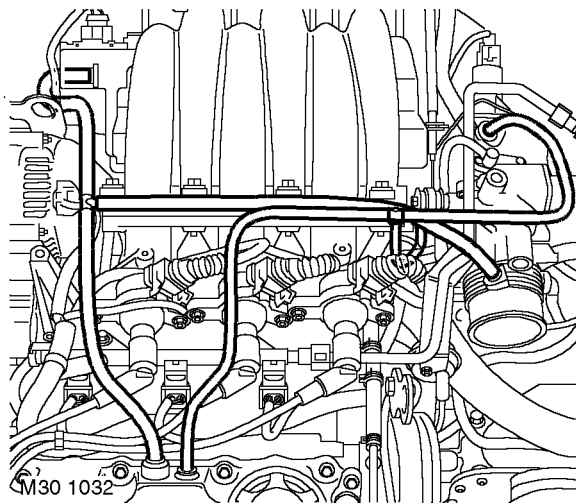

6. Depress locking collars and release vacuum/ breather hose from purge control valve and LH camshaft cover. Release clip securing hose to 'T' piece and remove hose.
7. Depress locking collars and release vacuum/ breather hoses from throttle body, LH and RH camshaft cover and remove hose.

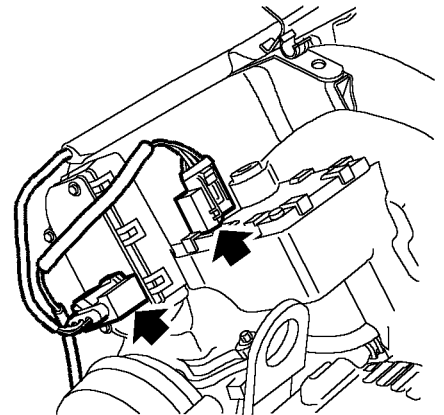

M30 1033

8. Disconnect multiplugs from VIS motors.

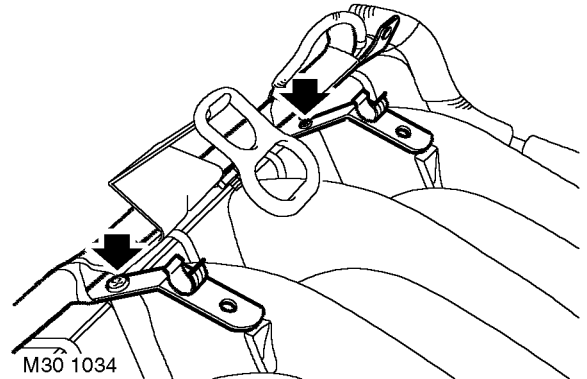

M30 1034

9. Remove 2 screws securing engine harness brackets to inlet manifold chamber and position harness aside.

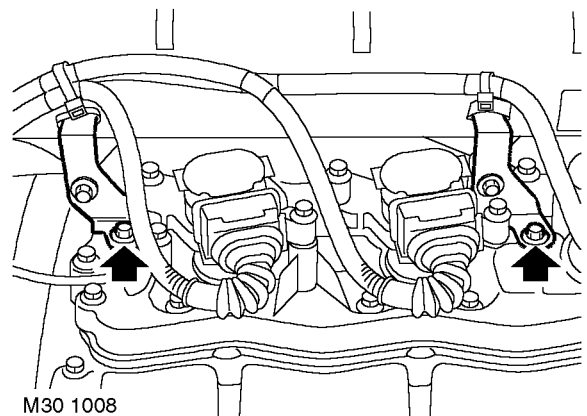

M30 1008

10. Remove 2 bolts securing inlet manifold chamber rear support brackets to RH camshaft cover.



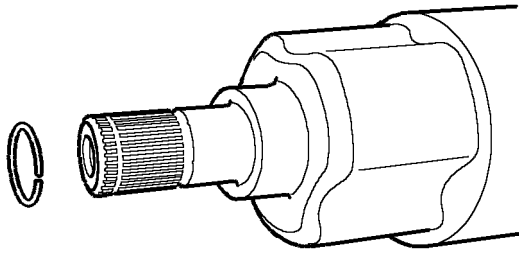

M41 7695

9. Remove and discard circlip from LH drive shaft.

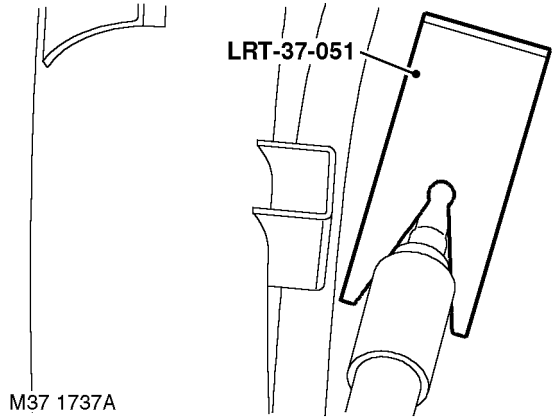

M37 1737A

12. Use **LRT-37-051** to release and disconnect clutch pipe connection.

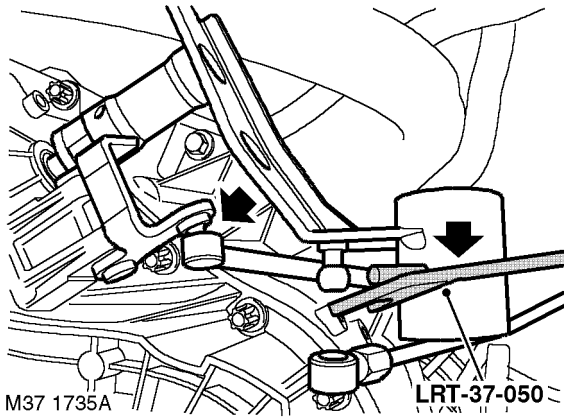

M37 1735A

LRT-37-050

10. Use **LRT-37-050** and release gear change rods from quadrant.

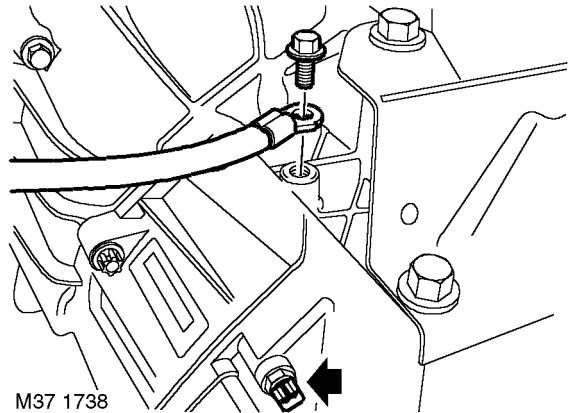

M37 1738

- 13. Remove bolt and release earth lead from gearbox.
- 14. Disconnect multiplug from 1st gear switch.
- 15. Fit lifting chains to lifting eye and take weight of engine.

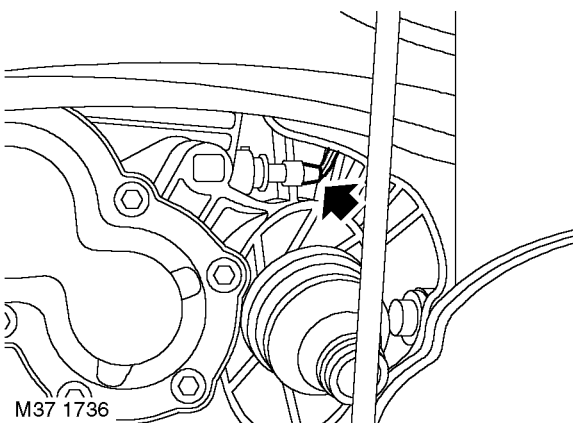

M37 1736

11. Disconnect reverse lamp switch multiplug.

# INTERMEDIATE REDUCTION DRIVE

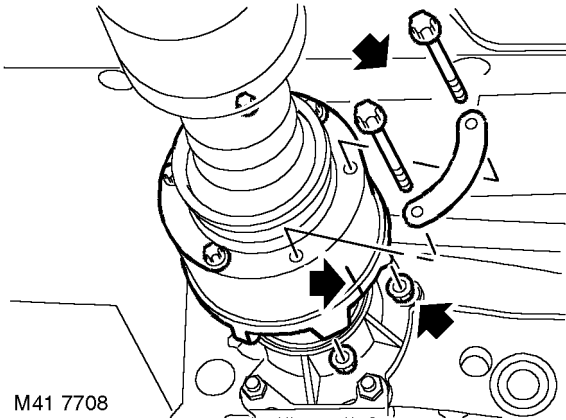

13. Remove 6 nuts and bolts securing propeller shaft to IRD drive flange.
14. Release propeller shaft from IRD drive flange and tie shaft aside.

**CAUTION:** Care must be taken to support the Tripode joint when removed from the IRD unit. To avoid damage to gaiter or steel can, the joint should not be allowed to fully extend or be dropped.

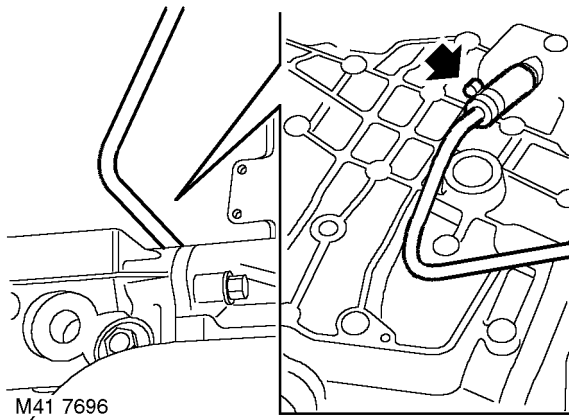

15. Disconnect breather hose from IRD housing.
16. Position container to collect coolant spillage.

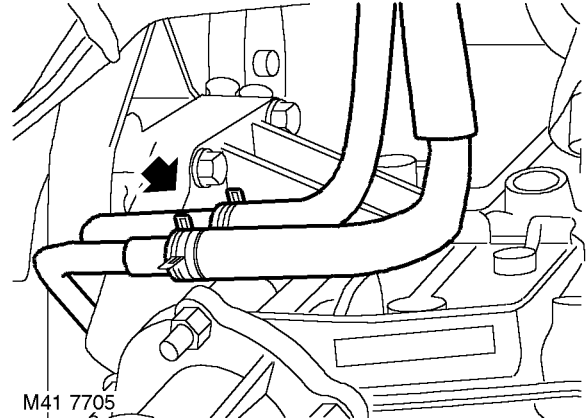

17. Release clips and disconnect coolant hoses from IRD.

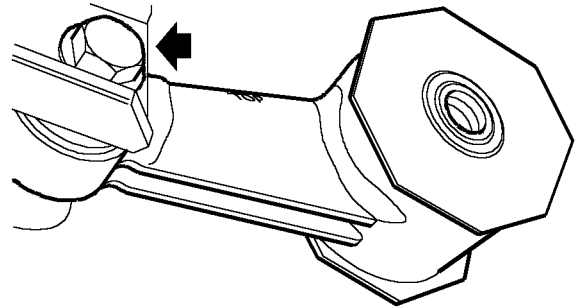

18. Remove bolt securing engine lower steady to IRD support bracket.
19. Remove lower engine steady noting that 'TOP' mark on engine steady faces uppermost.



**Gasket - end cover - IRD housing - KV6**

41.27.05

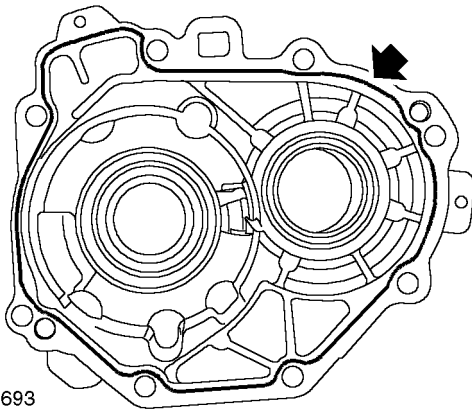

M41 7693

2. Apply a narrow bead of sealant, Part No. STC 3254 to mating face of end cover.
3. Fit end cover to IRD and tighten bolts progressively to 30 Nm (22 lbf.ft).
4. Fit IRD support bracket and tighten bolts sufficiently only to pull mating faces together.
5. Final tighten bolts securing IRD support brackets in the following sequence:
  - M10 bolts securing support brackets to IRD 50 Nm (37 lbf.ft)
  - 3 bolts securing support bracket to cylinder block 25 Nm (18 lbf.ft)
  - 3 bolts securing support bracket to sump at 45 Nm (33 lbf.ft).
6. Fit lower engine steady.
  - ☞ **ENGINE - Td4, REPAIRS, Engine steady - lower.**
7. Fit heat shield.
8. Fit nut securing heat shield to IRD and tighten to 45 Nm (33 lbf.ft).
9. Fit bolts securing manifold heat shield to IRD support bracket and tighten to 9 Nm (7 lbf.ft).
10. Fit nut securing heat shield to IRD pinion housing and tighten to 30 Nm (22 lbf.ft).
11. Fit drive shaft RH seal.
  - ☞ **INTERMEDIATE REDUCTION DRIVE, REPAIRS, Seal - driveshaft - RH.**
12. Fill IRD to correct level with fluid.
  - ☞ **INTERMEDIATE REDUCTION DRIVE, ADJUSTMENTS, Intermediate reduction drive (IRD) fluid - drain & refill - Non NAS.**

**Remove**

1. Drain fluid from IRD.
  - ☞ **INTERMEDIATE REDUCTION DRIVE, ADJUSTMENTS, Intermediate reduction drive (IRD) fluid - drain & refill - Non NAS.**
  - ☞ **INTERMEDIATE REDUCTION DRIVE, ADJUSTMENTS, Intermediate reduction drive (IRD) lubrication system - drain & refill - NAS.**
2. **NAS models:** Remove RH catalytic converter.
  - ☞ **EMISSION CONTROL, REPAIRS, Catalytic converter - RH - KV6 - NAS.**
3. Remove drive shaft RH seal.
  - ☞ **INTERMEDIATE REDUCTION DRIVE, REPAIRS, Seal - driveshaft - RH.**

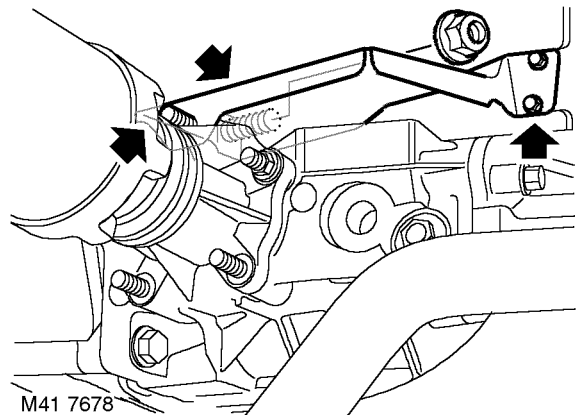

M41 7678

4. **Non NAS models:** Remove nut securing manifold heat shield to IRD unit.
5. **Non NAS models:** Remove nut securing heat shield to IRD pinion housing.
6. **Non NAS models:** Remove 2 bolts securing heat shield and remove heat shield.
7. Remove lower engine steady.
  - ☞ **ENGINE - K SERIES KV6, REPAIRS, Engine steady - lower.**

## INTERMEDIATE REDUCTION DRIVE

---

10. Lower axle and remove jack.
11. Fit underbelly panel.  
☞ **EXTERIOR FITTINGS, REPAIRS, Panel - underbelly.**
12. Remove stands and lower vehicle.

---

### Seal - pinion gear housing - K1.8

---

🔑 41.29.11

#### Remove

1. Remove underbelly panel.  
☞ **EXTERIOR FITTINGS, REPAIRS, Panel - underbelly.**
2. Drain fluid from IRD.  
☞ **INTERMEDIATE REDUCTION DRIVE, ADJUSTMENTS, Intermediate reduction drive (IRD) fluid - drain & refill - Non NAS.**
3. Raise one rear wheel for rotation of propeller shaft to access bolts.



4. Reference mark front propeller shaft for reassembly.
5. Remove 6 nuts and bolts securing propeller shaft to IRD drive flange.
6. Release propeller shaft from IRD drive flange and tie shaft aside.

**CAUTION: Care must be taken to support the Tripode joint when removed from the IRD unit. To avoid damage to gaiter or steel can, the joint should not be allowed to fully extend or be dropped.**

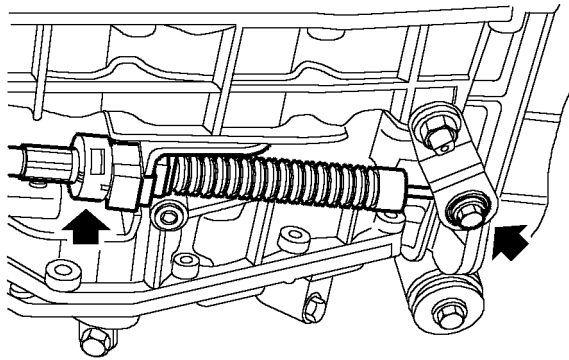

M44 1648

7. Loosen selector cable trunnion nut.
8. Release clip securing selector cable to gearbox bracket, remove selector cable and collect trunnion from selector lever.

**Refit**

1. Position trunnion to selector lever, locate inner cable through trunnion, do not tighten nut at this stage.
2. Position selector cable to gearbox bracket and secure with clip.
3. Locate cable in selector housing and secure outer cable in clip.
4. Secure outer cable to selector housing with 'C' clip.
5. Secure inner cable to selector lever.
6. Fit front console.  
**INTERIOR TRIM COMPONENTS, REPAIRS, Console - front.**
7. Check and adjust selector cable.  
**AUTOMATIC GEARBOX - JATCO, ADJUSTMENTS, Selector cable - adjust.**
8. Fit underbelly panel.  
**EXTERIOR FITTINGS, REPAIRS, Panel - underbelly.**
9. Remove stands and lower vehicle.

**Selector indicator**

44.15.10

**Remove**

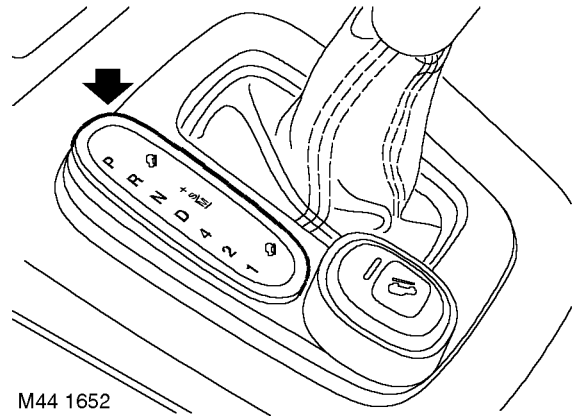

M44 1652

1. Release selector indicator from selector lever trim panel.

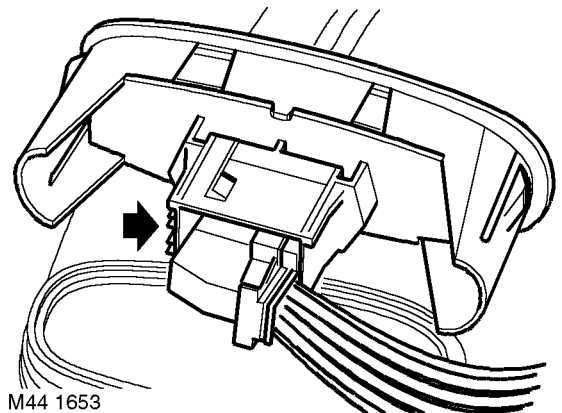

M44 1653

2. Disconnect multiplug from selector indicator and remove indicator.

**Refit**

1. Connect multiplug to selector indicator.
2. Position selector indicator to selector lever trim panel.

## AUTOMATIC GEARBOX - JATCO

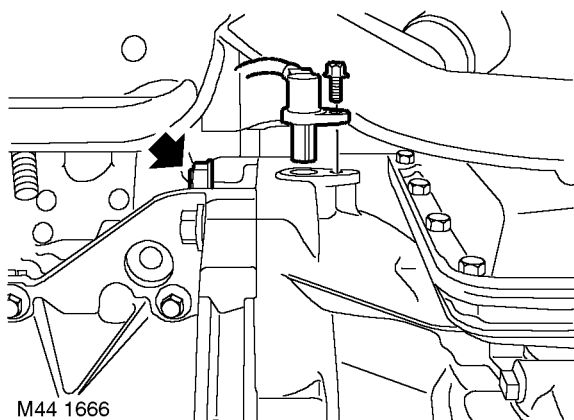

24. Remove bolt securing CKP sensor to gearbox, release sensor and position aside.
25. Remove nut and bolt, adjacent to CKP sensor, securing gearbox to engine.

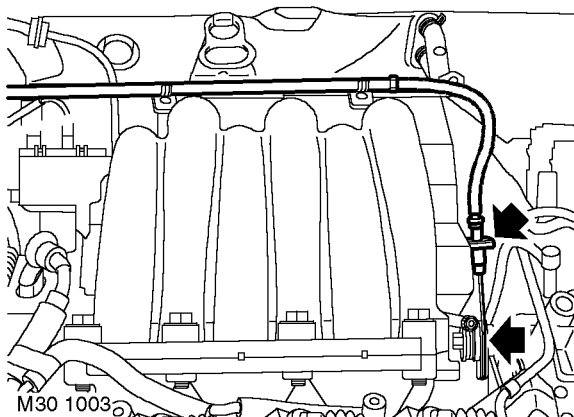

26. Release throttle cable from abutment bracket and disconnect cable from throttle body cam, if fitted.

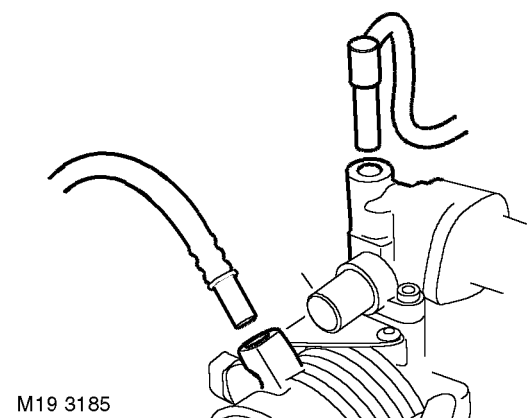

27. Depress collars and release 2 breather pipes from throttle housing, if fitted.

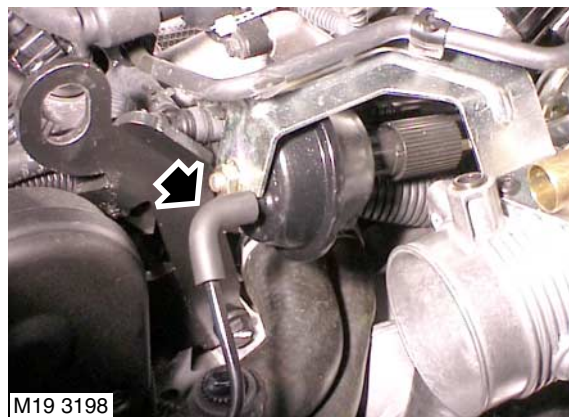

28. **Vehicles with cruise control:** Disconnect vacuum hose from cruise control actuator.

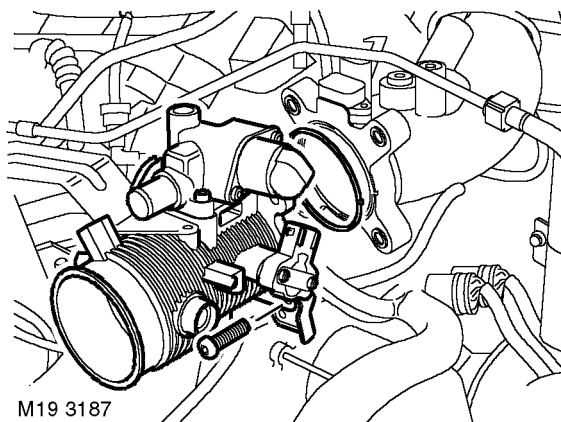

29. Remove 4 Torx screws securing throttle housing, release throttle housing and position aside.  
*Non NAS throttle housing shown.*



**Refit**

1. Clean cooler mounting points.
2. Position fluid cooler to mounting, fit bolts, tighten 2 bolts to 45 Nm (33 lbf.ft) and remaining bolt to 25 Nm (18 lbf.ft).
3. Connect coolant hoses and secure with clips.
4. Lubricate new 'O' rings with clean transmission fluid and fit to fluid cooler hoses.
5. Connect hoses to fluid cooler and tighten unions to 18 Nm (13 lbf.ft).
6. Top-up gearbox fluid level.  
☞ **MAINTENANCE, MAINTENANCE, Automatic Gearbox – JATCO.**
7. Connect battery earth lead.
8. Refill cooling system.  
☞ **COOLING SYSTEM - Td4, ADJUSTMENTS, Coolant - drain and refill.**
9. Fit underbelly panel.  
☞ **EXTERIOR FITTINGS, REPAIRS, Panel - underbelly.**

**Fluid cooler - KV6**

☞ 44.24.10

**Remove**

1. Remove underbelly panel.  
☞ **EXTERIOR FITTINGS, REPAIRS, Panel - underbelly.**
2. Position container to collect fluid spillage.  
**WARNING: Observe due care when draining gearbox fluid as the fluid can be very hot.**

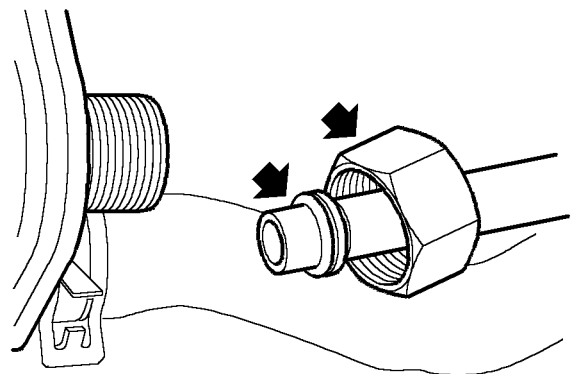

M44 1654

3. Disconnect 2 fluid cooler hose unions and discard 'O' rings.  
**CAUTION: Always fit plugs to open connections to prevent contamination.**
4. Position container to collect coolant spillage.

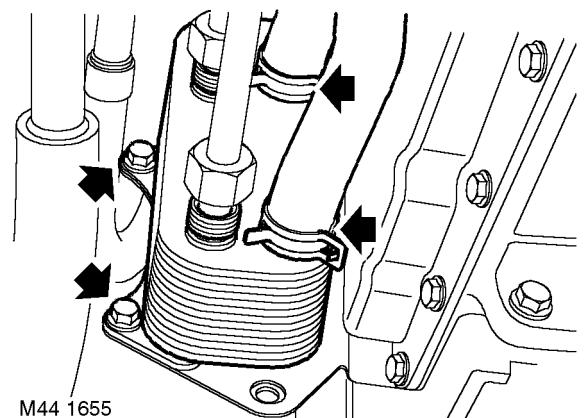

M44 1655

5. Release 2 clips and disconnect coolant hoses from fluid cooler.  
**CAUTION: Always fit plugs to open connections to prevent contamination.**
6. Remove 2 bolts securing fluid cooler.

# DRIVESHAFTS

---

---

## Gaiter - outer - rear

---

🔑 47.11.03

### Remove

1. Disconnect battery earth lead.
2. Raise rear of vehicle.

**WARNING: Do not work on or under a vehicle supported only by a jack. Always support the vehicle on safety stands.**

3. Remove road wheel.
4. Remove drive shaft outer joint.

👉 **DRIVESHAFTS, REPAIRS, Bell & joint - outer - rear.**

5. Slide gaiter from shaft.

### Refit

1. Clean drive shaft and gaiter.
2. Apply grease from the sachet to the joint.
3. Fit new gaiter to shaft.
4. Fit drive shaft outer joint.  
👉 **DRIVESHAFTS, REPAIRS, Bell & joint - outer - rear.**
5. Fit road wheel(s) and tighten nuts to 115 Nm (85 lbf.ft).
6. Remove stands and lower vehicle.
7. Connect battery earth lead.

---

## Bell & joint - outer - rear

---

🔑 47.11.04

### Remove

1. Disconnect battery earth lead.
2. Raise rear of vehicle.

**WARNING: Do not work on or under a vehicle supported only by a jack. Always support the vehicle on safety stands.**

3. Remove road wheel.
4. Remove drive shaft.

👉 **DRIVESHAFTS, REPAIRS, Shaft with both joints - rear.**

5. Place drive shaft in vice.
6. Release both gaiter clips and discard.

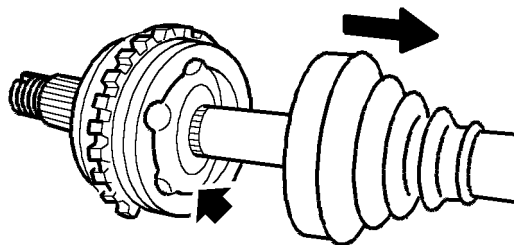

M47 0354

7. Slide gaiter along shaft to gain access to outer joint.
8. Using a suitable drift against the inner part of the joint, remove joint from shaft.
9. Inspect gaiter for damage and renew if necessary.
10. Remove and discard circlip from drive shaft.

### Refit

1. Clean drive shaft and gaiter.
2. Fit new circlip to drive shaft.
3. Position outer joint to shaft, use a screwdriver to press circlip into its groove and push joint fully onto shaft.
4. Apply grease from the sachet to the joint.
5. Position gaiter to joint and use a 'Band-it thriftool' **LRT-99-019** to secure the 2 new clips.
6. Fit drive shaft.  
👉 **DRIVESHAFTS, REPAIRS, Shaft with both joints - rear.**
7. Fit road wheel(s) and tighten nuts to 115 Nm (85 lbf.ft).
8. Remove stands and lower vehicle.
9. Connect battery earth lead.



**Differential assembly**

🔑 51.15.01

**Remove**

1. Remove both drive shafts.  
 📌 **DRIVESHAFTS, REPAIRS, Shaft with both joints - LH.**  
 📌 **DRIVESHAFTS, REPAIRS, Shaft with both joints - RH.**

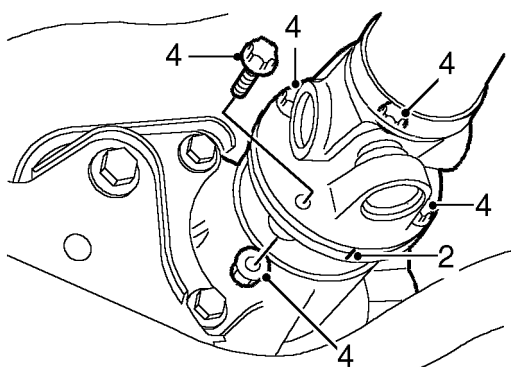

M51 0087

2. Reference mark rear propeller shaft for reassembly.
3. Position container to catch oil spillage
4. Remove 4 nuts and bolts securing propeller shaft to differential. Release propeller shaft and tie aside.
5. Support weight of differential assembly on a jack.

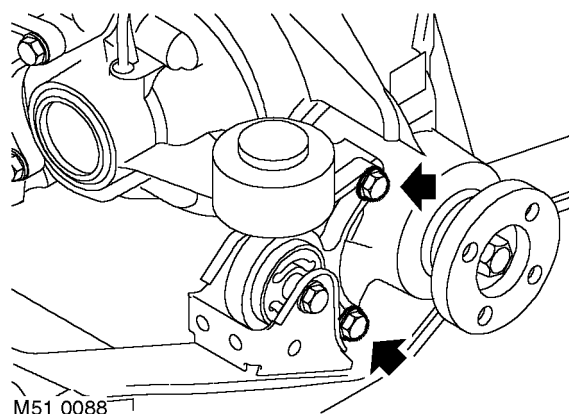

M51 0088

6. Remove 2 bolts securing differential to front mounting.

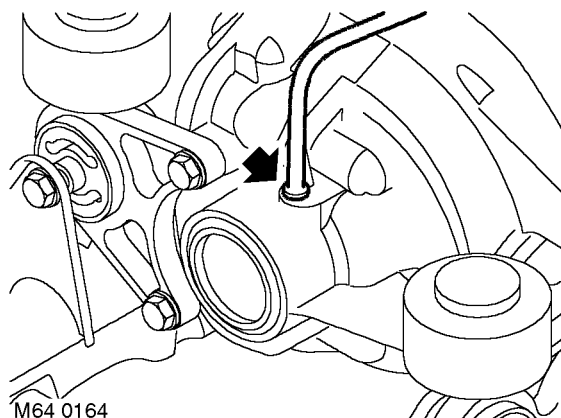

M64 0164

7. Depress red locking collar and disconnect breather pipe from differential casing.

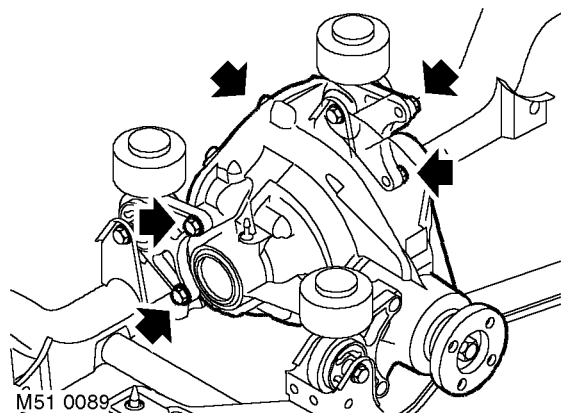

M51 0089

8. Remove 4 bolts securing differential assembly to rear mountings.
9. With assistance, rotate differential assembly through 90° and remove from subframe.

**Refit**

1. With assistance position differential assembly to subframe and locate in mountings, fit bolts but do not tighten at this stage.

## STEERING

---

18. Pressures outside the above tolerance indicates a fault.
19. To determine if fault is in steering pump or steering rack, close the test valve for a maximum of 5 seconds.  
**CAUTION: Pump damage will occur if test valve is closed for longer periods.**
20. If gauge does not register correct reading, suspect faulty pump.
21. If PAS pump pressure is correct and steering is heavy at idle and becomes light as engine RPM is increased, suspect pump flow rate.
22. If maximum pump pressure is correct, suspect steering rack.
23. On completion stop engine and remove test equipment.
24. Clean PAS pump and pipe union.
25. Fit new 'O' ring to high pressure pipe, align to PAS pump and tighten union to 25 Nm (18 lbf.ft).
26. Fit bolt securing high pressure pipe clip and tighten to 8 Nm (6 lbf.ft).
27. Check and top-up PAS fluid level.  
 **MAINTENANCE, MAINTENANCE, Intermediate Reduction Drive - Non NAS models.**



## Pump - steering - Td4

🔑 57.20.14

### Remove

1. Disconnect battery earth lead.
2. Remove hydramount.  
👉 **ENGINE - Td4, REPAIRS, Hydramount - engine - RH.**

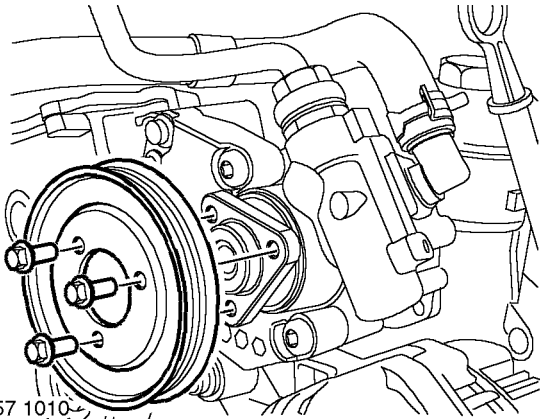

M57 1010

3. Loosen 3 PAS pump pulley bolts.
4. Remove ancillary drive belt.  
👉 **CHARGING AND STARTING, REPAIRS, Ancillary drive belt - Td4.**
5. Raise engine on hoist.
6. Remove bolts and remove PAS pump pulley.
7. Cover alternator to prevent PAS oil contamination.

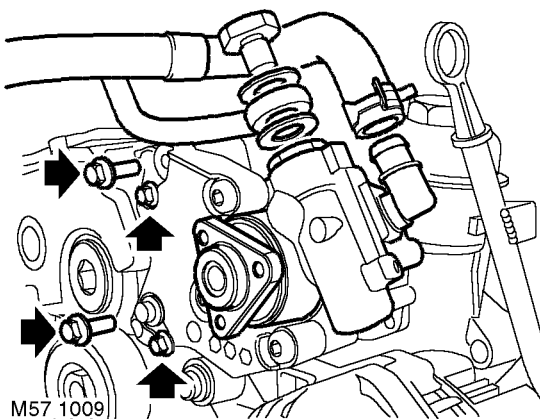

M57 1009

8. Place container beneath PAS pump, release clip and remove feed hose to pump. Allow fluid to drain.

**CAUTION:** Care must be taken to ensure that oil or fluid does not enter or contaminate the alternator.

9. Remove banjo bolt securing fluid outlet hose to PAS pump, release hose, remove and discard sealing washers.

**CAUTION:** Before disconnecting or removing components, ensure the immediate area around joint faces and connections are clean. Plug open connections to prevent contamination.

10. Remove 4 bolts and remove PAS pump.

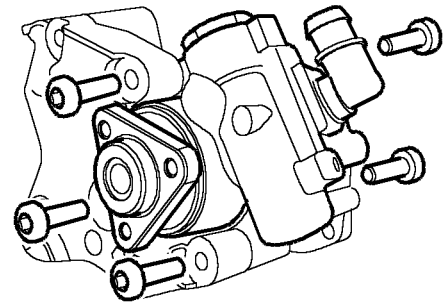

M57 1075

11. Remove 5 Torx bolts securing PAS pump to mounting brackets. Collect mounting brackets.

### Refit

1. Position PAS pump to mounting brackets, fit and tighten Torx bolts to 25 Nm (18 lbf.ft).
2. Position pump to mounting, fit bolts and tighten M8 bolts to 25 Nm (18 lbf.ft) and M6 bolts to 10 Nm (7.5 lbf.ft).
3. Using new sealing washers, fit PAS outlet hose to pump and tighten banjo bolt to 25 Nm (18 lbf.ft).
4. Clean PAS pump and mating faces.
5. Fit inlet hose to PAS pump and secure with new clip.
6. Fit PAS pump pulley to PAS pump and tighten bolts to finger tight.
7. Fit ancillary drive belt.  
👉 **CHARGING AND STARTING, REPAIRS, Ancillary drive belt - Td4.**
8. Tighten PAS pump pulley bolts to 10 Nm (7.5 lbf.ft).
9. Fit hydramount.  
👉 **ENGINE - Td4, REPAIRS, Hydramount - engine - RH.**
10. Connect battery earth lead.

## STEERING

---

### Refit

1. Fit radio switches to steering wheel and secure with screws.
2. **Models with cruise control:** Fit cruise control switches to steering wheel and secure with screws.
3. Position harness to horn, cruise control (if fitted) and radio switches and secure in clips.
4. Position horn switch and connect Lucars.
5. Repeat for other horn switch.
6. Connect multiplugs to cruise control and radio control switches.
7. **Td4 models:** Position damper, fit and tighten screws.
8. Remove tape from rotary coupler.
9. Ensure road wheels are in straight ahead position and indicator cancelling cam is aligned horizontally.
10. Fit steering wheel to column and ensure spokes are horizontal.
11. Fit new self locking nut and tighten to 45 Nm (33 lbf.ft).
12. Connect multiplug to rotary coupler.
13. Fit drivers airbag.



**RESTRAINT SYSTEMS, REPAIRS,  
Air bag - steering wheel.**

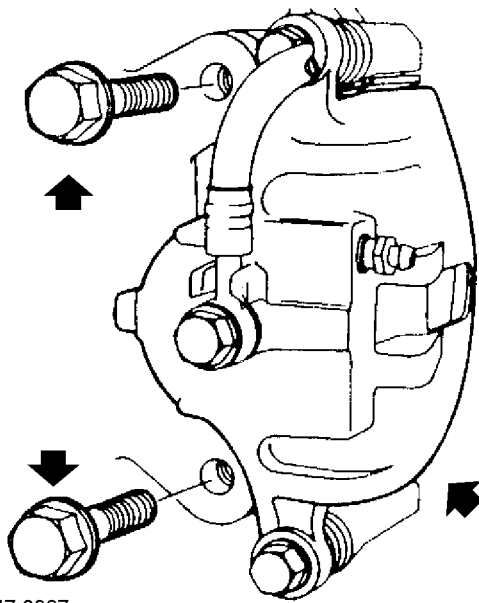

M47 0387

9. Remove 2 bolts securing brake caliper to hub. Release caliper from hub and tie aside.  
**CAUTION: Do not allow caliper to hang on brake hose.**

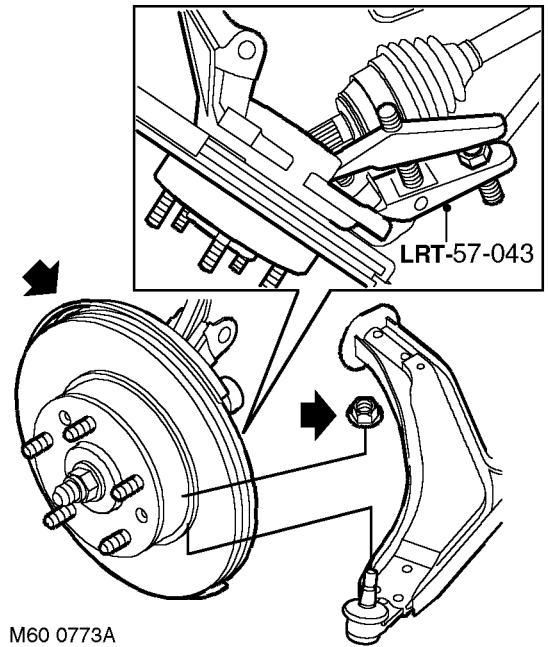

M60 0773A

13. Remove nut securing lower arm ball joint. discard nut.
14. Break taper joint using **LRT-57-043**.
15. Remove hub assembly.

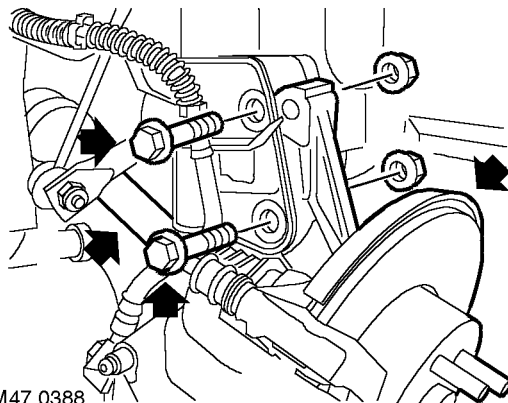

M47 0388

10. Remove 2 nuts and bolts securing hub to damper.
11. Release drive shaft from hub.
12. Tie drive shaft aside.

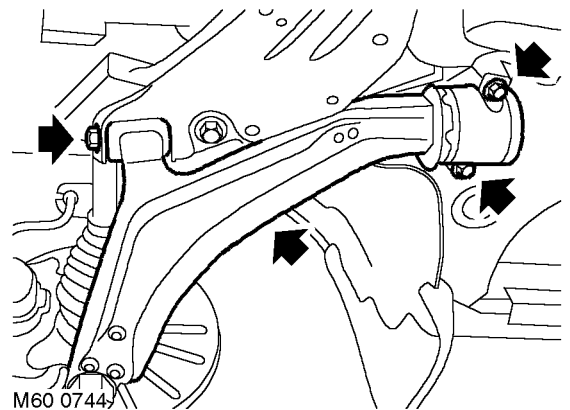

M60 0744

16. Remove 2 bolts securing lower arm rear bush housing.
17. Remove bolt securing lower arm front mounting.
18. Remove lower arm.

## REAR SUSPENSION

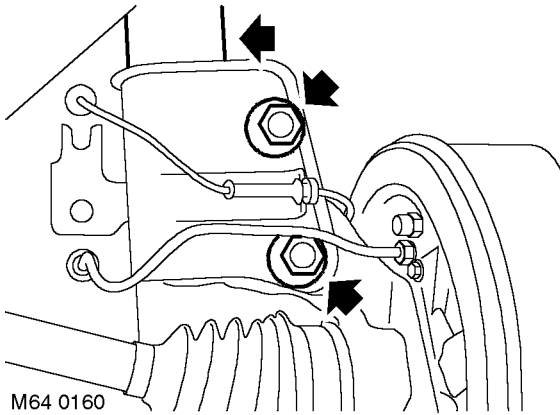

9. Remove 2 nuts and bolts securing hub to damper.
10. Release damper from hub.
11. Remove rear quarter lower casing.  
☞ INTERIOR TRIM COMPONENTS, REPAIRS, Trim casing - rear quarter - lower - 3 door.  
☞ INTERIOR TRIM COMPONENTS, REPAIRS, Trim casing - rear quarter - lower - 5 door.

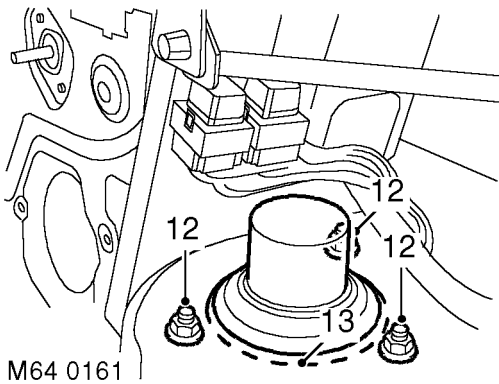

12. Remove 3 nuts from damper top mounting and remove spring and damper assembly.
13. Remove rubber seal from top mounting.

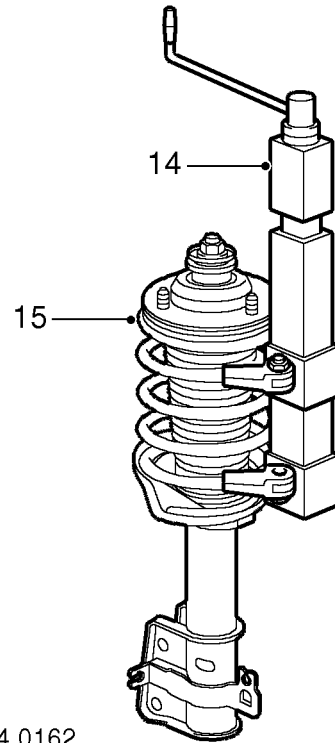

14. Position a suitable spring compressor in vice.  
**CAUTION: Note alignment of top mounting, spring and damper dust cover.**
15. Position spring and damper assembly to spring compressor. Compress spring.
16. Reference mark between top mounting and spring.



**Drum - rear**

70.12.03

**Remove**

1. Raise rear of vehicle.  
*WARNING: Do not work on or under a vehicle supported only by a jack. Always support the vehicle on safety stands.*
2. Remove road wheel.
3. Release handbrake.

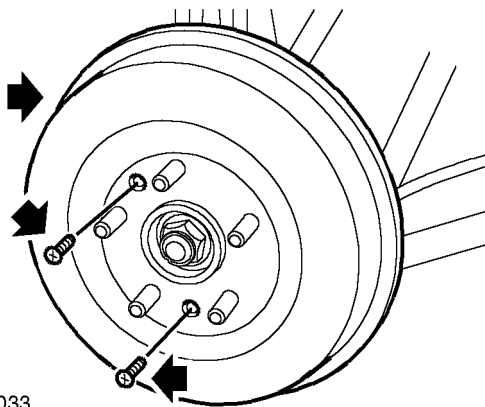

M70 1033

4. Remove 2 screws securing brake drum and remove brake drum.  
*NOTE: If brake drum cannot be removed, release brake shoe adjustment as follows:*

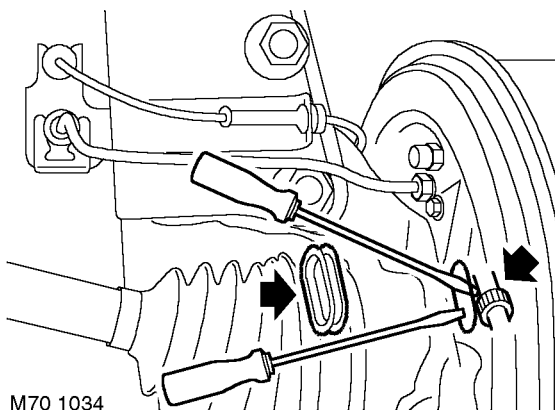

M70 1034

5. Remove rubber grommet from rear of backplate.
6. Using 2 flat bladed screwdrivers, release ratchet and turn the adjuster to increase the shoe to drum clearance.

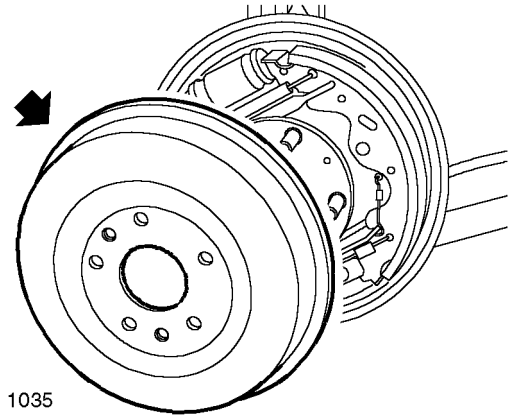

M70 1035

7. Remove brake drum.  
*WARNING: Do not use compressed air to clean brake components. Dust from friction materials can be harmful if inhaled.*

**Refit**

1. Renew brake drum if scored, grooved or cracked.
2. Check wheel cylinder pistons for freedom of movement.
3. Clean backplate and brake disc with brake cleaning fluid.  
*WARNING: Do not use petroleum based fluid as damage will occur to rubber components*

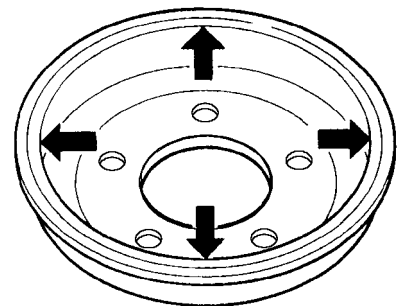

M70 1030

4. Measure inside diameter of drum at 2 points.  
Drum internal diameter: New = 254 mm.  
Service limit: = 255.49 mm. Drum ovality limit: = 0.012 mm. Renew drum if outside limits.
5. Examine wheel cylinder dust seals for signs of brake fluid leakage, a certain amount of dampness is usual. However, if excessive fluid is apparent, lift dust seals and check for leakage. Renew wheel cylinders and brake shoes if linings are contaminated.

# BRAKES

## Refit

1. Rotate disc by hand and scrape all scale and rust from around edge of disc.
2. Scrape rust from pad locating surfaces on caliper.
3. Clean dust from calipers using brake cleaning fluid.

**WARNING: Do not use an air line to blow dust from brake assembly. Do not use petroleum based fluid as damage will occur to rubber components.**

4. Position bleed bottle, connect bleed hose to bleed screw and loosen screw.
5. Press piston back into housing and tighten bleed screw to 10 Nm (7.5 lbf.ft).
6. Disconnect bleed hose and remove bottle.

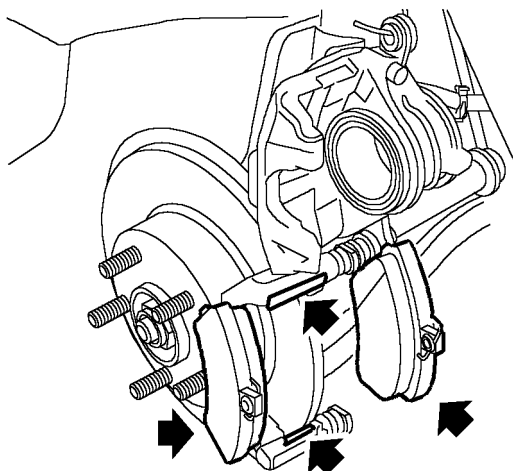

M70 1081A

7. Fit pad retainers to caliper bracket.

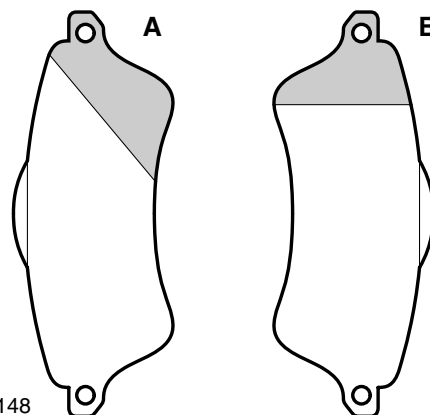

M70 1148

8. Fit pads to caliper bracket.

*The leading edge of the pads have chamfers on them, the chamfers are asymmetric. It is imperative that the pads are correctly fitted. Pad 'A' in illustration must be fitted to the inboard side of the caliper. Pad 'B' must be fitted to the outboard side of the caliper. Illustration shows a LH pair of pads.*

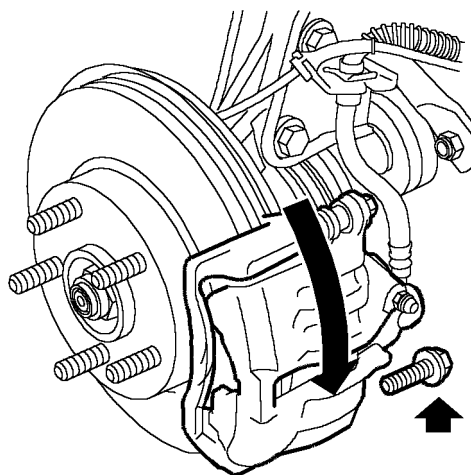

M70 1082

9. Lower caliper housing over pads.
10. Ensure flats on guide pins locate with lugs on caliper housing. Fit bolts and tighten to 27 Nm (20 lbf.ft).
11. Repeat procedure for other side.
12. Fit road wheel(s) and tighten nuts to 115 Nm (85 lbf.ft).
13. Remove stands and lower vehicle.
14. Depress brake several times to set pad to disc clearance.
15. Check and top-up brake fluid.



**Sensor & harness - front wheel - RH**

70.65.29

**Remove**

1. Raise front of vehicle.  
*WARNING: Do not work on or under a vehicle supported only by a jack. Always support the vehicle on safety stands.*
2. Remove road wheel.
3. Remove front wheel arch liner.  
 **EXTERIOR FITTINGS, REPAIRS, Liner - front wheel arch.**

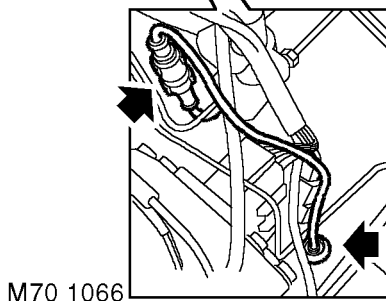
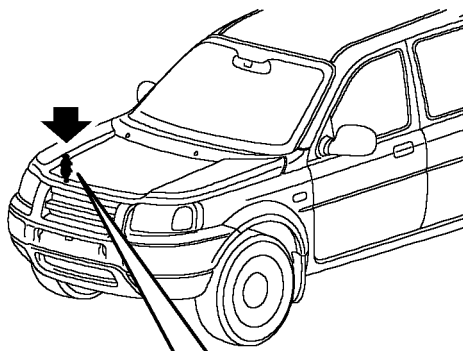

4. Locate ABS sensor harness on inner wing.
5. Release ABS sensor multiplug from body clip and disconnect multiplug.
6. Release grommet from wing valance and pull harness through.

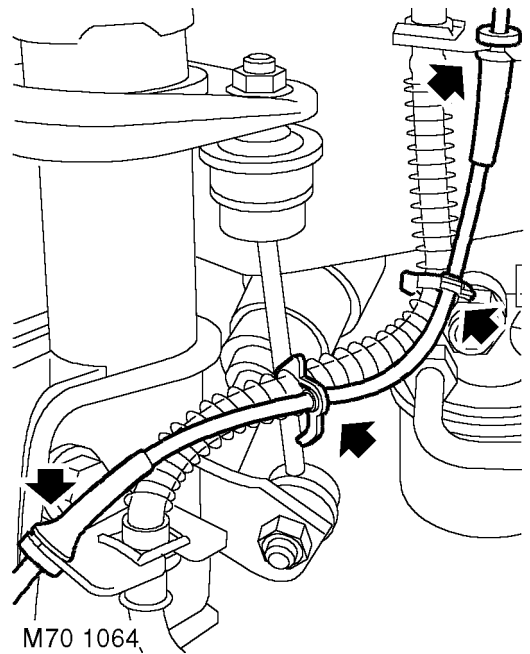

7. Release 2 grommets from wing valance and damper brackets
8. Release harness from brake hose clips.

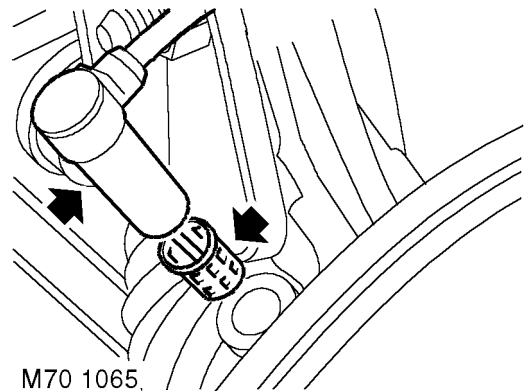

9. Remove bolt securing ABS sensor to hub, if fitted.
10. Release ABS sensor from hub.
11. Remove ABS sensor and harness.
12. Remove bush from front hub.

**Refit**

1. Clean ABS sensors and mating faces.
2. Fit new bush to front hub.
3. Apply anti-seize grease to sensor.
4. Fit sensor to hub, ensure sensor is fully seated in hub.

**CAUTION: Ensure ABS sensor is fully located into hub, so that sensor touches pole wheel teeth.**

# RESTRAINT SYSTEMS

## Adjustable mounting - seat belt - 'B' pillar

🔑 76.73.26

### Remove

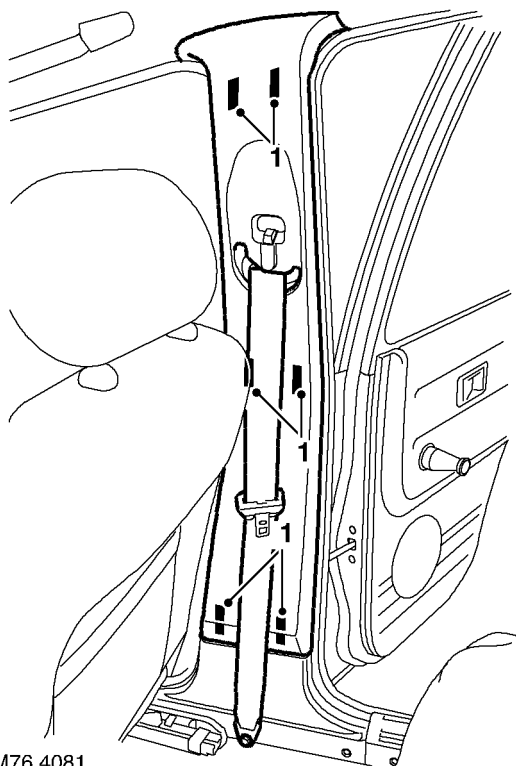

1. Release 'B/C' post upper finisher from 6 clips and position aside.

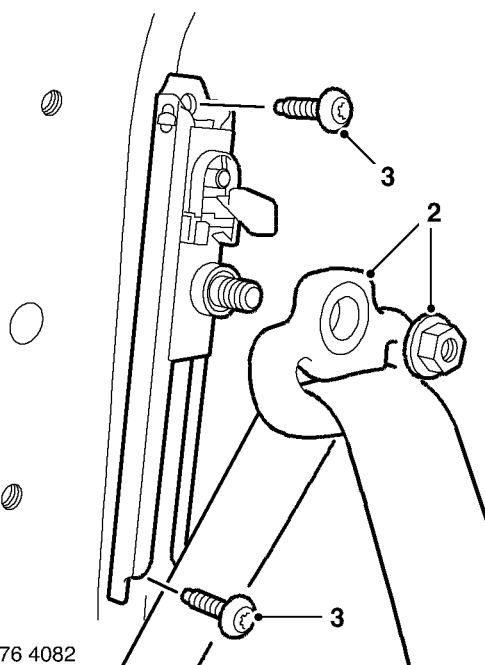

2. Remove nut from seat belt upper mounting and remove belt bracket.
3. Remove 2 Torx bolts from adjustable mounting and remove mounting.

### Refit

1. Position mounting and tighten Torx bolts to 26 Nm (19 lbf.ft).
2. Fit upper belt bracket and tighten nut to 31 Nm (23 lbf.ft).
3. Position 'B/C' post upper finisher and secure with clips.



**Airbag module - driver's - deployment using tool LRT-86-003 (off vehicle)**

76.74.99

These guidelines are written to aid authorised personnel to carry out the safe disposal of airbag modules when removed from the vehicle.

**If a vehicle is to be scrapped and contains an undeployed airbag module, the module must be manually deployed. This operation should only be carried out using the following recommended manual deployment procedure. Before the deployment procedure commences, check the condition of the deployment tool and associated flyleads are suitable to proceed.**

**WARNING: Only use approved deployment equipment, and only deploy SRS components in a well ventilated designated area. Ensure SRS components are not damaged or ruptured before deployment. Notify the relevant authorities.**

**WARNING: Always remove the ignition key from the ignition switch, disconnect the vehicle battery and wait 10 minutes before commencing work on the SRS system.**

**WARNING: When removing, testing or installing an airbag module, do not lean directly over it.**

**WARNING: Only personnel who have undergone the appropriate training should undertake deployment of airbag and seat belt pre-tensioner modules.**

**CAUTION: Deployment in the vehicle will damage the steering wheel. If the vehicle is not being scrapped, deploy the module away from the vehicle in accordance with the correct procedure.**

**Deploy**

1. Check condition of deployment tool **LRT-86-003** and associated flyleads.
2. Remove airbag module from steering wheel.

**RESTRAINT SYSTEMS, REPAIRS, Air bag - steering wheel.**

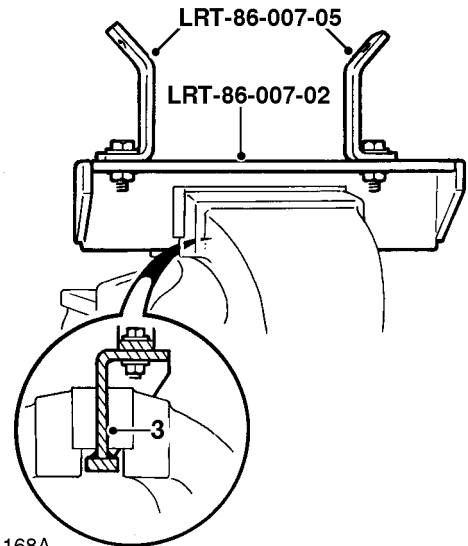

M76 4168A

3. Position tool **LRT-86-007-02** in vice, ensuring that vice jaws grip tool above bottom flange to prevent possibility of tool being forced upwards from vice. Tighten vice.
4. Secure airbag module to tool **LRT-86-007-02** using both fixings **LRT-86-007-05**.
5. Ensure airbag module mounting brackets are secure.

**WARNING: Ensure the deployment tool is not connected to the battery.**

## DOORS

---

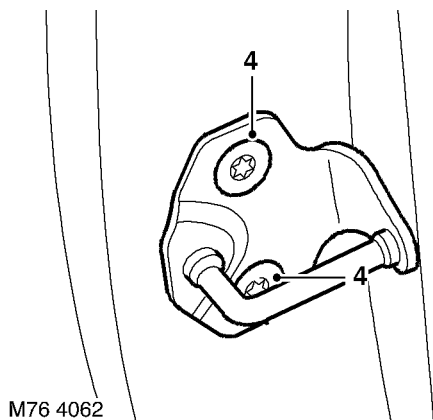

M76 4062

4. Loosen 2 Torx bolts securing door latch striker.
5. Use jack to assist with door alignment.
6. Tighten hinge bolts.
7. Remove jack and close door to check for correct alignment.
8. When alignment is satisfactory, tighten hinge bolts to 30 Nm (22 lbf.ft).
9. Adjust door latch striker.  
👉 **DOORS, ADJUSTMENTS, Door - front or rear - adjust on striker.**



## Trim casing - front door - 5 door

🔑 76.34.01

### Remove

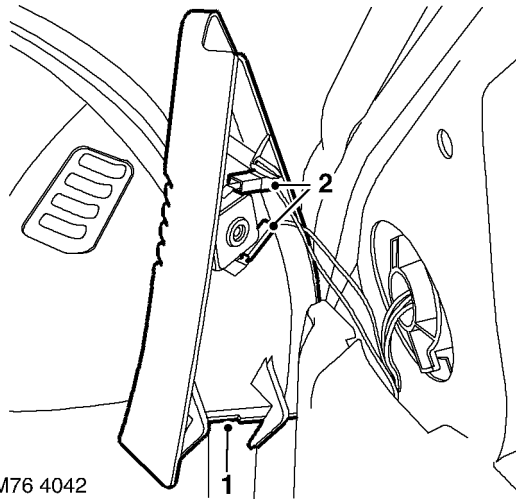

M76 4042

1. Release cheater panel from front door.
2. Disconnect Lucars from tweeter speaker.
3. Remove cheater panel.

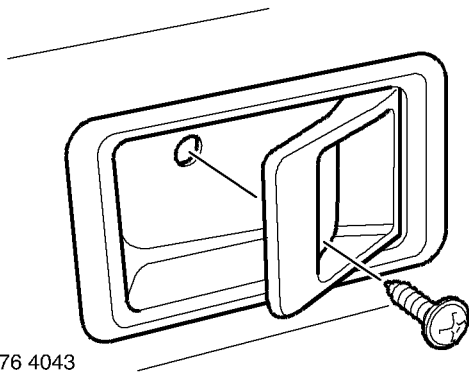

M76 4043

4. Remove screw securing door handle escutcheon to door and remove escutcheon.

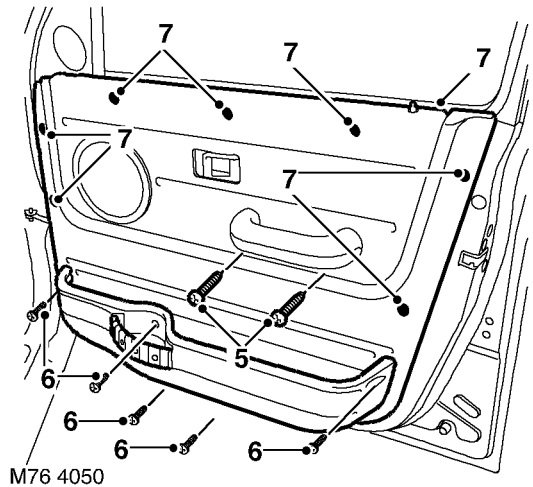

M76 4050

5. Remove 2 screws from door pull.
6. Remove 5 screws from door pocket.
7. Release 7 trim studs and remove casing.

*NOTE: Do not carry out further dismantling if component is removed for access only.*

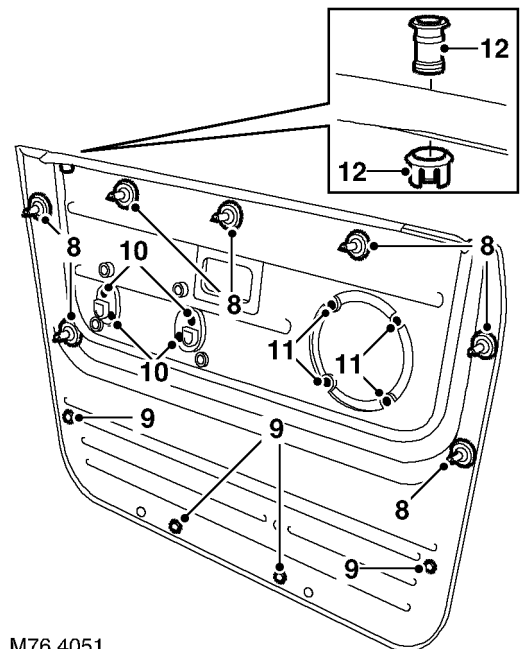

M76 4051

8. Remove 7 trim studs from casing.
9. Remove 4 Torx screws securing door pocket to trim casing and remove pocket.
10. Remove 4 Torx screws securing door pull to trim casing and remove door pull.
11. Remove 4 Torx screws securing door speaker grille to trim casing and remove grille.
12. Release retainer and remove sill button guide.

# DOORS

---

## Remote control - rear door

---

🔑 76.37.32

### Remove

1. Remove rear door plastic sheet.  
👉 **DOORS, REPAIRS, Plastic sheet - rear door.**

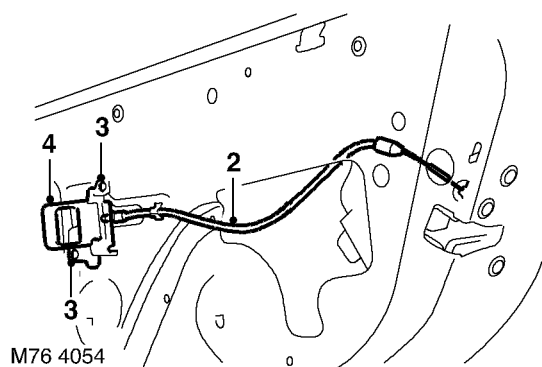

2. Release cable from door release.
3. Drill out 2 rivets from door release.
4. Remove door release.

### Refit

1. Connect cable to door release.
2. Position door release and secure with rivets.
3. Fit rear door plastic sheet.  
👉 **DOORS, REPAIRS, Plastic sheet - rear door.**

---

## Operating cable - lock remote control - 5 door

---

🔑 76.37.60

### Remove

1. Remove door latch.  
👉 **DOORS, REPAIRS, Latch - front door - 5 door.**  
👉 **DOORS, REPAIRS, Latch - rear door.**

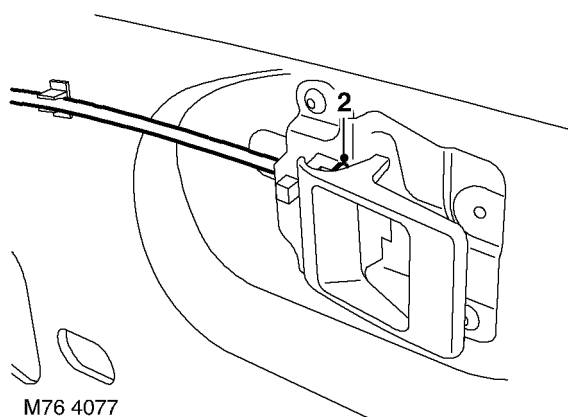

2. Release cable from interior door release and remove cable.

### Refit

1. Connect cable to interior door release.
2. Fit door latch.  
👉 **DOORS, REPAIRS, Latch - front door - 5 door.**  
👉 **DOORS, REPAIRS, Latch - rear door.**



## Side rail - integral roof rack - 5 door

🔑 76.11.30

### Remove

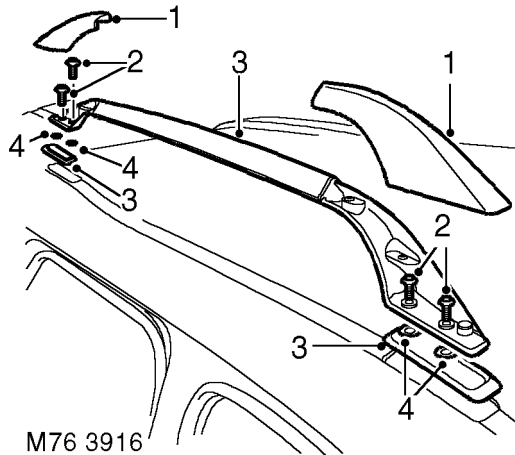

1. Remove finishers from feet of side rail.
2. Remove 4 Torx screws securing side rail to roof panel.
3. Remove side rail and 2 gaskets.  
*NOTE: Do not carry out further dismantling if component is removed for access only.*
4. Remove seal from each torque bolt.
5. Remove Torx bolts from side rail.

### Refit

1. Fit Torx bolts and seals to replacement side rail.
2. Fit gaskets to side rail.
3. Position side rail and tighten Torx bolts to 22 Nm (16 lbf.ft).
4. Fit finishers to feet of side rail.

## Bonnet

🔑 76.16.01.99

### Remove

1. Support bonnet in open position.
2. Fit protection covers to wings and mark hinge outline on bonnet if bonnet is to be refitted.

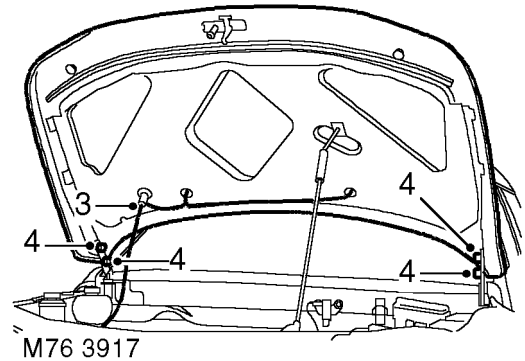

3. Disconnect windscreen washer tube at elbow joint.
4. With assistance, remove bolts securing hinges to bonnet and remove bonnet.

### Refit

1. With assistance, position bonnet to hinges. Fit and lightly tighten bolts.
2. Connect windscreen washer tube.
3. Close bonnet. Check that bonnet is aligned to both front wings and that gaps are equal. If necessary, adjust bonnet alignment and/or gaps.
4. Finally tighten hinge bolts to 9 Nm (7 lbf.ft).

## INTERIOR TRIM COMPONENTS

---

### Trim casing - rear quarter - upper - 5 door

---

🔑 76.13.13

#### Remove

1. Remove rear quarter lower casing.  
👉 **INTERIOR TRIM COMPONENTS, REPAIRS, Trim casing - rear quarter - lower - 5 door.**

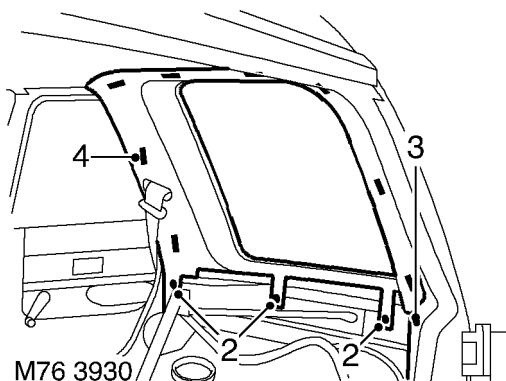

2. Remove 3 screws securing upper casing to body.
3. Remove retainer from tail door seal.
4. Release trim casing from 8 retaining clips.

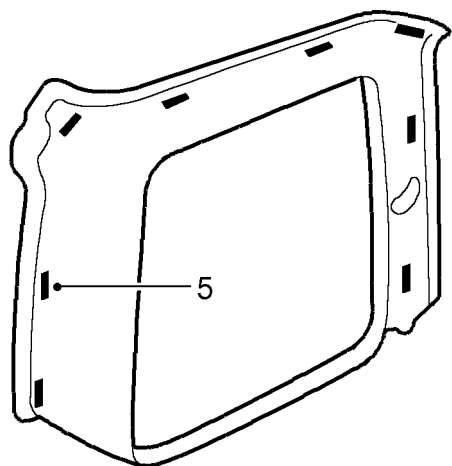

5. Remove upper casing from loadspace.
6. Remove 8 retaining clips from casing.

#### Refit

1. Fit retaining clips to casing.
2. Position casing in loadspace, locate and secure retaining clips.
3. Fit retainer to tail door seal.
4. Fit screws securing bottom of casing.
5. Fit rear quarter lower casing.  
👉 **INTERIOR TRIM COMPONENTS, REPAIRS, Trim casing - rear quarter - lower - 5 door.**

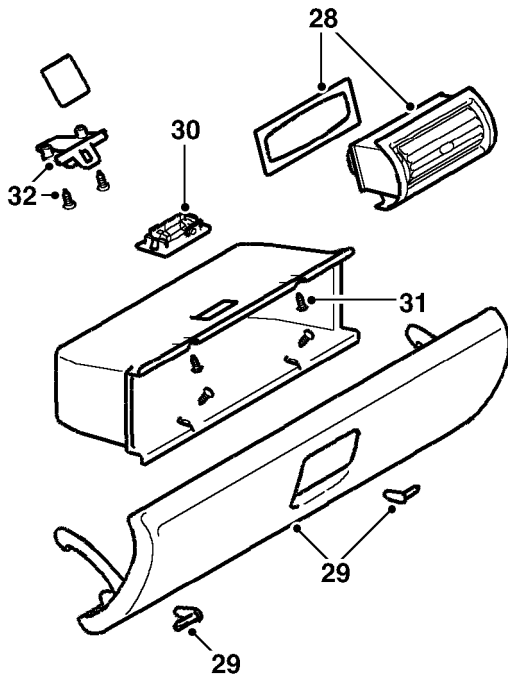

M76 3990

- 28. Remove 4 face level vents and collect seals.
- 29. Remove glove box hinge pins and remove glove box lids.
- 30. Remove glove box lamp and mat.
- 31. Remove 4 screws from glove box and remove glove box.
- 32. Remove 2 screws from each glove box lock and remove locks.
- 33. Remove switch blank.



M76 3995

- 34. Disconnect multiplug from immobilisation ECU.
- 35. Remove 2 nuts securing immobilisation ECU to fascia and remove ECU.
- 36. Remove fascia and coin tray mats.

**Refit**

- 1. Fit fascia and coin tray mats.
- 2. Fit immobilisation ECU to fascia and secure with nuts.
- 3. Connect multiplug to immobilisation ECU.
- 4. Fit switch blank.
- 5. Fit glove box locks to fascia and secure with screws.
- 6. Fit glove box and secure with screws.
- 7. Fit glove box lamp and mat.
- 8. Fit glove box lids and secure hinge pins.
- 9. Fit face level vents and seals to fascia.
- 10. Fit centre bracket and secure with screws.
- 11. **Models without passenger airbag:** Fit grab handle and secure with nuts.
- 12. Fit instrument pack lower cover and secure with screws.
- 13. Fit instrument pack to fascia and secure with screws.
- 14. Fit fascia harness to fascia and secure with clips.
- 15. Connect Lucars to glove box lamp and switch.
- 16. Connect multiplugs to mirror switch and headlamp levelling switch.
- 17. Fit mirror switch and headlamp levelling switch.
- 18. Connect multiplugs to instrument pack.
- 19. Fit instrument pack upper cover and secure with screws.
- 20. Connect multiplugs to switches on instrument bezel finisher, fit bezel and secure with screws.
- 21. With assistance fit fascia to vehicle and secure with bolts.
- 22. Connect fascia harness multiplugs to main harness.
- 23. **Models with passenger airbag:** Fit passenger airbag.
  - ☞ **RESTRAINT SYSTEMS, REPAIRS, Air bag - fascia - passenger.**
- 24. **Models without passenger airbag:** Fit fascia storage box.
  - ☞ **INTERIOR TRIM COMPONENTS, REPAIRS, Stowage box - fascia.**
- 25. Fit 'A' post upper trim finishers.
  - ☞ **INTERIOR TRIM COMPONENTS, REPAIRS, Trim finisher - 'A' post - upper - renew.**
- 26. Fit clock.
  - ☞ **INSTRUMENTS, REPAIRS, Clock.**
- 27. Open drivers glove box lid and remove fuse box cover.
- 28. Connect multiplugs to fusebox.
- 29. Fit fusebox cover and close glove box lid.
- 30. Fit steering column lower cover and secure with screws.
- 31. Fit wiper/indicator switch and tighten clamping screw.
- 32. Connect multiplugs to wiper/indicator switch.

## SCREENS

---

8. Clean frame and edge of screen with solvent.  
**Do not touch cleaned or primed surfaces with fingers.**
9. Apply etch primer to any bare metal on frame.
10. Apply bonding agent to screen and allow to cure.
11. Apply primer over etch primer on frame.
12. Apply activator over old sealer on frame.
13. Allow activator to cure.
14. Fit pre-cut nozzle to sealer cartridge, remove lid and shake out crystals. Install cartridge in applicator gun.

*Nozzle will need modification to achieve required bead section.*

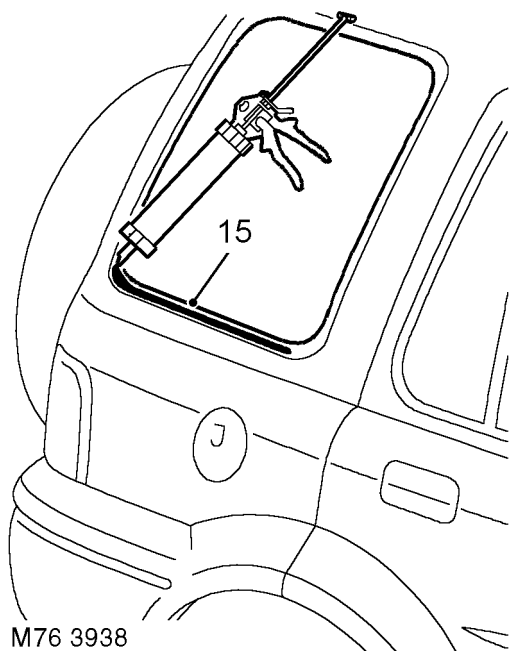

21. Test sealer for leaks, apply additional sealer if necessary. If water is used, allow sealer to dry before testing. Spray water around glass and check for leaks. Mark leakage points and apply additional sealer as necessary when area is completely dry.

22. Fit rear quarter upper casing.

**INTERIOR TRIM COMPONENTS, REPAIRS, Trim casing - rear quarter - upper - 5 door.**

15. Apply a continuous bead of sealer around edge of frame as shown. Make bead slightly thicker at each corner.
16. Check for breaks and air bubbles in sealer.
17. Position glass to body and align to reference tape.
18. Lightly press glass to fully seat sealer.
19. Secure glass with tape until sealer has cured.
20. Remove protective covers and tape.

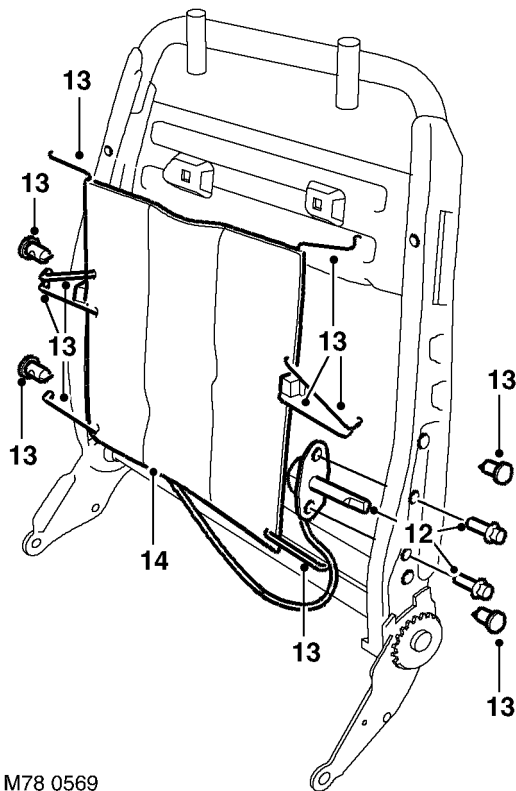

M78 0569

12. Remove 2 bolts from cable control and release cable control.
13. Release 8 lumbar support retainers from squab frame and collect 4 hook retainers.
14. Remove lumbar support mechanism.

#### Refit

1. Position lumbar support to squab frame and locate hook retainers
2. Fit lumbar support retainers to squab frame.
3. Position cable control and tighten bolts.
4. Fit squab cover and pad to frame.
5. Fit head restraint guide tubes.
6. Position straps and secure with pop rivets.
7. Fit squab cover to squab pad and squab frame.
8. Secure squab cover at base of squab frame.
9. Fit lumbar support control knob.
10. Fit squab frame to cushion frame and tighten Torx bolts to 45 Nm (33 lbf.ft).
11. Fit side covers and secure retaining studs.
12. Fit head restraint.
13. Fit recline control knob.
14. Fit front seat.  
 **SEATS, REPAIRS, Front seat.**

## Latch - rear squab - RH

 78.80.05

#### Remove

1. Remove rear seat squab cover.  
 **SEATS, REPAIRS, Cover - squab - rear seat - RH.**

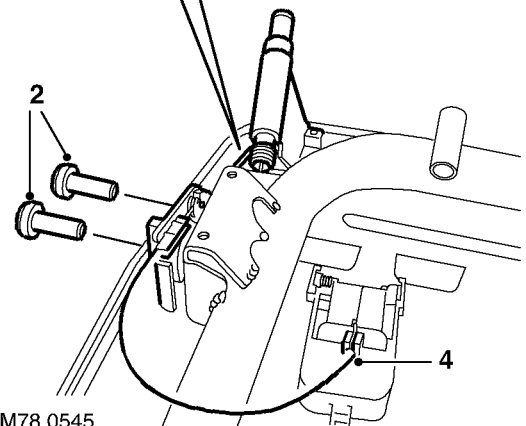
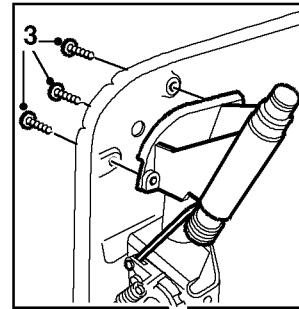

M78 0545

2. Remove 2 Torx screws from squab lock.
3. Remove 3 screws from lock button.
4. Release cable from lever abutment and remove latch assembly.

#### Refit

1. Position latch assembly to frame and locate cable in abutment.
2. Fit Torx screws to squab lock and tighten to 20 Nm (15 lbf.ft).
3. Fit screws to lock button.
4. Fit squab cover.  
 **SEATS, REPAIRS, Cover - squab - rear seat - RH.**

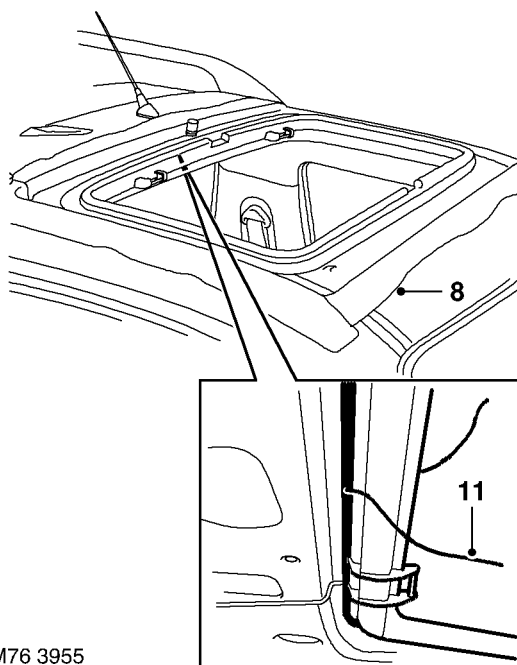

M76 3955

8. Mask up roof and sun roof aperture.
9. Cover interior of vehicle with protective sheet.
10. Make a cut through the sealer at the back of the sun roof, a 90° bend in the cutting tool will help.

**WARNING: Wear suitable eye protection when removing and refitting glass.**

11. Using suitable cutting wire, cut through PU sealer securing sun roof to roof.  
*NOTE: If multi-strand cutting wire is used, a sawing action can be used to cut through heavy sealant deposits around corners.*

12. Remove sun roof.

## Refit

1. Clean surrounding area with solvent.  
**WARNING: Wear protective gloves when handling glass, solvents and primers.**
2. Use a vacuum cleaner to clear away any waste.
3. Cut sealer on roof flange down to a smooth even finish.
4. Etch prime and paint any damaged areas.
5. Apply primer over etch primer on flange.
6. Apply activator over old sealer on flange.
7. Allow activator to cure.
8. Fit pre-cut nozzle to sealer cartridge, remove lid, shake out crystals and fit cartridge to applicator gun. If necessary modify the nozzle to achieve required bead section.
9. Apply a continuous bead of sealer around roof flange. Make bead slightly thicker at the corners.
10. Check for breaks and air bubbles in sealer.
11. With assistance position sunroof and align to roof aperture.
12. Fit sunroof tray seal.

### **SUNROOF, REPAIRS, Seal - tray - sun /sliding roof - front.**

13. Position sunroof clamping plates, fit and tighten screws.
14. Connect drain tubes and secure with new cable ties.
15. Remove body and trim protection.
16. Position wind deflectors, fit and tighten screws.
17. Fit 'T' bar and glass panels.
18. Fit headlining.

### **INTERIOR TRIM COMPONENTS, REPAIRS, Headlining - 3 door.**



## Hard top - remove for access & refit

76.61.01.99

### Remove

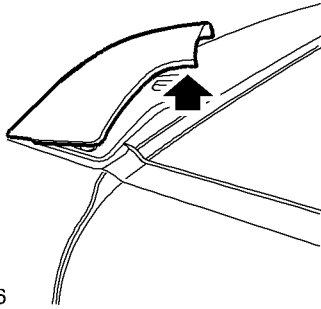

M76 4136

1. Remove covers from front of roof bars.

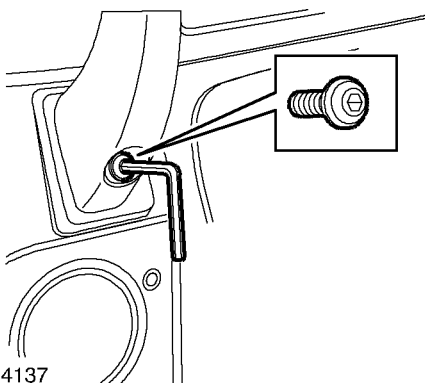
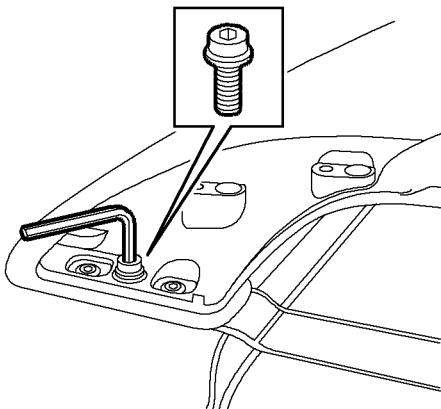

M76 4137

2. Remove 4 bolts securing roof bars and with assistance remove roof bars.

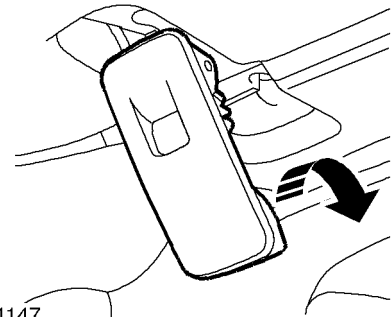

M76 4147

3. Release and disengage hard-back catches and with assistance remove hard-back.

### Refit

1. With assistance position hard-back and secure catches.
2. With assistance position roof bars, fit and tighten bolts.
3. Fit roof bar covers.

## BODY DIMENSIONS

---

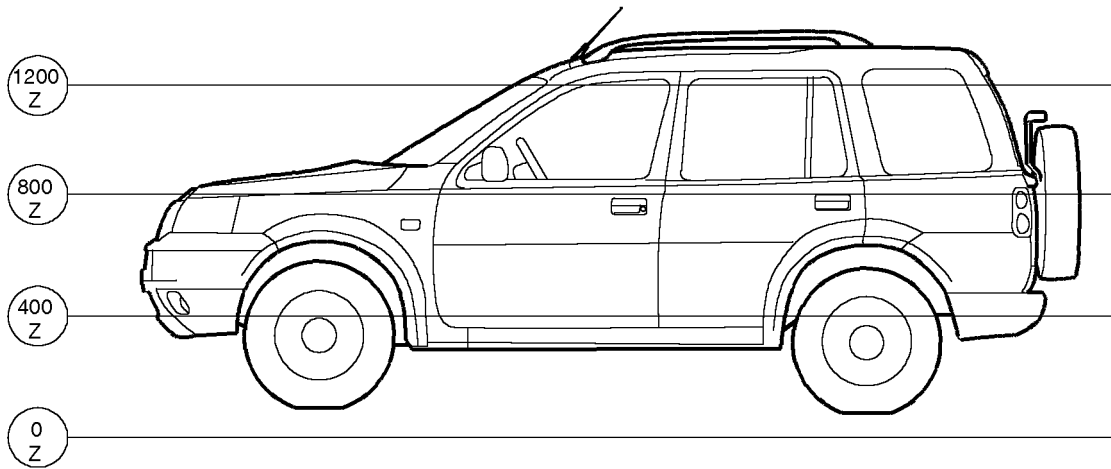

M77 1905



Rear end information

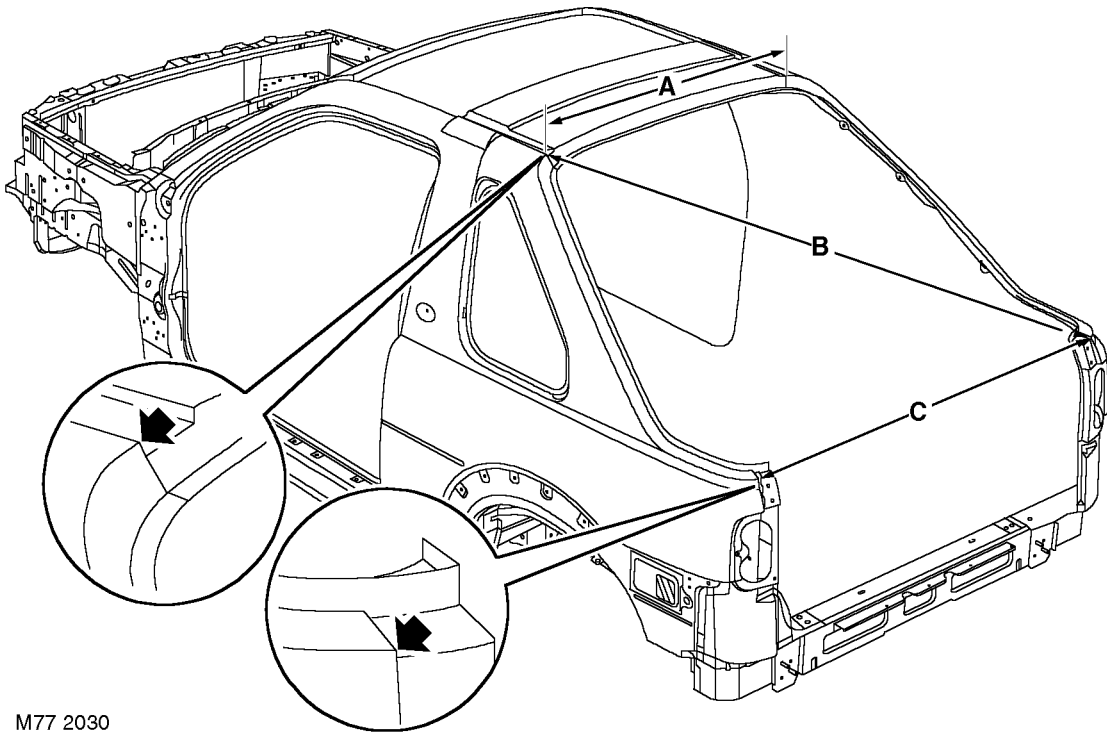

M77 2030

Item	From	To	Length
A	Top corner, on bodyside panel `LH`	Top corner, on bodyside panel `RH`	980 (38.582)
B	Top corner, on bodyside panel	Bottom corner, on bodyside panel	1684.5 (66.318)
C	Bottom corner, on bodyside panel `LH`	Bottom corner, on bodyside panel `RH`	1349 (53.110)

# PANEL REPAIRS

---

## Inner front end panels

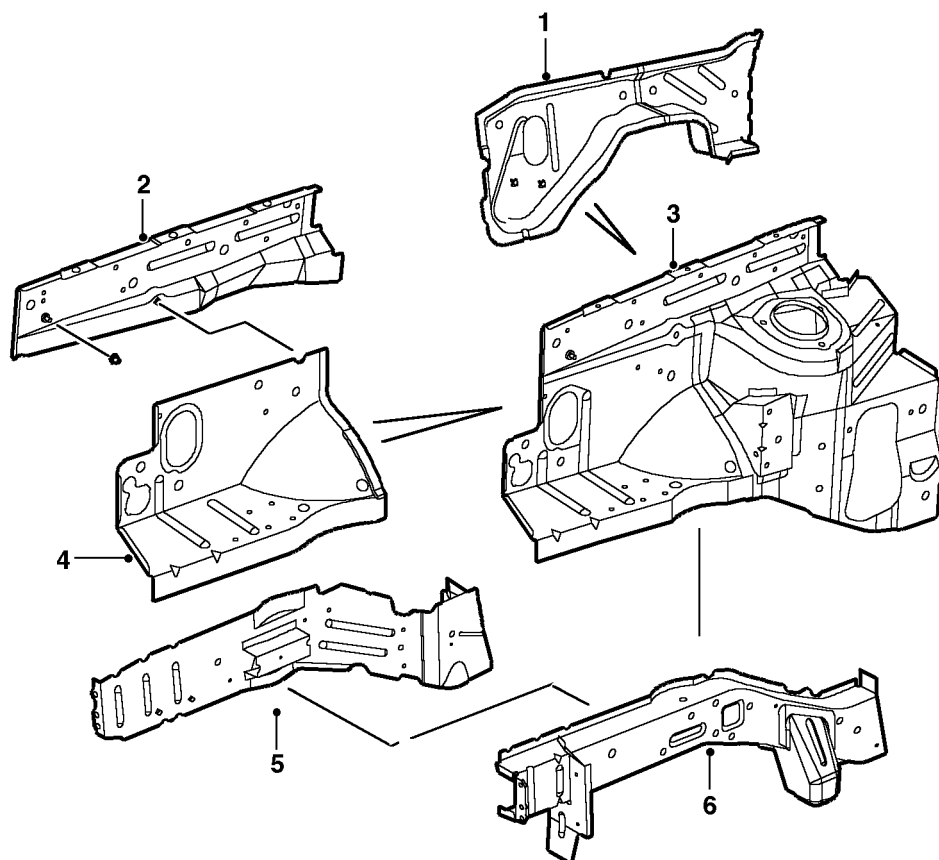

M77 2037

- 1 Valance outer reinforcement assembly
- 2 Valance upper front assembly
- 3 Front valance assembly
- 4 Valance front assembly
- 5 Front sidemember closing panel
- 6 Front sidemember assembly



**ECU locations (3 door model shown, 5 door model similar)**

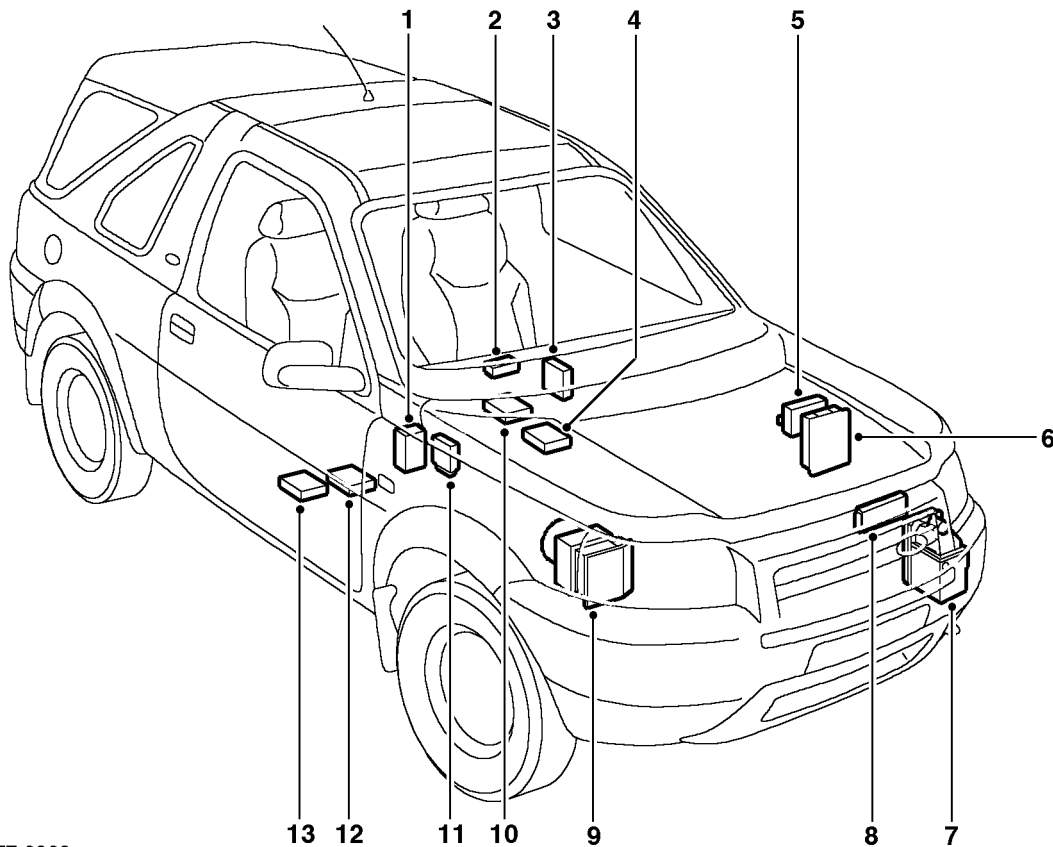

M77 2023

- 1 Central control unit (on forward side of passenger compartment fusebox, behind driver's glove box)
- 2 RF Receiver (on top of instrument pack)
- 3 Immobiliser ECU (rear of fascia)
- 4 DCU (SRS on transmission tunnel below heater)
- 5 EAT ECU (inside Environmental 'E' box)
- 6 ECM (inside 'E' box)
- 7 Fuel Burning Heater (behind wheelarch liner) 'Diesel only'
- 8 Cooling Fan Ecu (rear of radiator housing) all models except 1.8
- 9 ABS ECU (RH side front of engine compartment)
- 10 Folding door mirror ECU (on transmission tunnel under centre console)
- 11 Window lift ECU (on driver 'A' post)
- 12 Cruise Control Interface ECU (under R/H seat)
- 13 Cruise control ECU (under R/H seat)

## PANEL REPAIRS

---

10. Fit PAS fluid cooler.  
☞ **STEERING, REPAIRS, Oil cooler - Td4 & K1.8 models.**
11. Fit radiator.  
☞ **COOLING SYSTEM - K SERIES KV6, REPAIRS, Radiator assembly.**
12. Fit front bumper armature.
13. Fit front bumper valance.  
☞ **EXTERIOR FITTINGS, REPAIRS, Bumper - assembly - front.**
14. Connect all ECUs.
15. Connect alternator.
16. Connect battery earth lead.

---

### Bonnet locking platform

---

*In this procedure the bonnet locking platform reinforcement is also replaced in conjunction with the bonnet locking platform.*

#### Remove

1. Disconnect battery earth lead.
2. Disconnect alternator.
3. Disconnect all ECUs.
4. Remove front bumper valance.  
☞ **EXTERIOR FITTINGS, REPAIRS, Bumper - assembly - front.**
5. Remove radiator.  
☞ **COOLING SYSTEM - K SERIES KV6, REPAIRS, Radiator assembly.**
6. Remove both headlamp assemblies.  
☞ **LIGHTING, REPAIRS, Headlamp assembly.**
7. Remove horn.  
☞ **SECURITY, REPAIRS, Horn.**
8. Remove battery.  
☞ **CHARGING AND STARTING, REPAIRS, Battery.**
9. Remove air intake hose.
10. Remove bonnet lock.
11. Support bonnet in open position.
12. Remove bonnet stay.

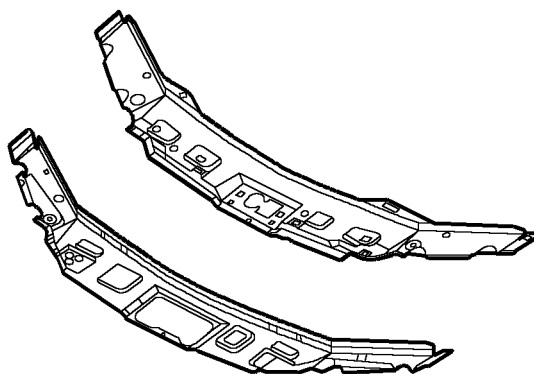

#### Repair



M77 2040

1. Remove existing panel(s), prepare panel joint faces and install new panel(s) in accordance with Panel Replacement Procedure.









15. Fit front bumper support bracket.
16. Fit front bumper valance.  
 **EXTERIOR FITTINGS, REPAIRS, Bumper - assembly - front.**
17. Fit front wing.  
 **EXTERIOR FITTINGS, REPAIRS, Wing - front.**
18. Fit front wheel arch liner.  
 **EXTERIOR FITTINGS, REPAIRS, Liner - front wheel arch.**
19. Fit road wheel(s) and tighten nuts to 115 Nm (85 lbf.ft).
20. Connect all ECUs.
21. Connect alternator.
22. Connect battery earth lead.

---

## Valance outer reinforcement

---

### Remove

1. Disconnect battery earth lead.
2. Disconnect alternator.
3. Disconnect all ECUs.
4. Remove road wheel(s).
5. Remove front wheel arch liner.  
 **EXTERIOR FITTINGS, REPAIRS, Liner - front wheel arch.**
6. Remove front wing.  
 **EXTERIOR FITTINGS, REPAIRS, Wing - front.**
7. Remove front bumper valance.  
 **EXTERIOR FITTINGS, REPAIRS, Bumper - assembly - front.**
8. Remove headlamp.  
 **LIGHTING, REPAIRS, Headlamp assembly.**
9. Release wiring from valance and position aside.
10. **LH side:** Remove battery.  
 **CHARGING AND STARTING, REPAIRS, Battery.**
11. **LH side:** Remove ECM.
12. **LH side:** Remove relay module.
13. **LH side:** Remove battery carrier.  
 **CHARGING AND STARTING, REPAIRS, Carrier - battery.**
14. **LH side:** Remove engine compartment fuse box and related wiring.
15. **RH side:** Remove PAS fluid reservoir.
16. **RH side:** Remove brake pipes from valance.

## PANEL REPAIRS

---

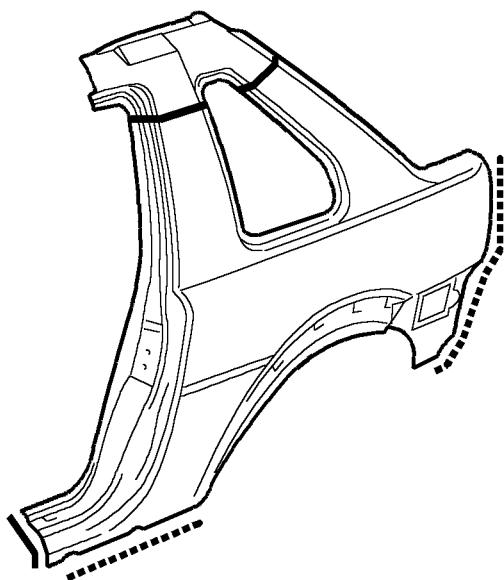

M77 2005

1. Remove existing panel(s), prepare panel joint faces and install new panel(s) in accordance with Panel Replacement Procedure. Punch or drill holes in new panel for plug welding as shown.
2. Arrow A is shown to highlight the fact that there are plug welds on the other side of the inner wheel arch as well. These are to weld the rear longitudinal to the inner wheel arch.

### Refit

1. **LH side:** Fit tail door striker to 'E' post.
2. **RH side:** Fit fuel tank.  
 **FUEL DELIVERY SYSTEM - DIESEL, REPAIRS, Tank.**
3. **RH side:** Fit fuel filler neck.  
 **FUEL DELIVERY SYSTEM - PETROL, REPAIRS, Filler neck.**
4. **RH side:** Fit tail door.  
 **DOORS, REPAIRS, Door - tail assembly - remove for access & refit.**
5. Secure vehicle harness to rear quarter.
6. Fit rear damper.  
 **REAR SUSPENSION, REPAIRS, Damper.**
7. Fit seal and rear quarter vent.  
 **EXTERIOR FITTINGS, REPAIRS, Body quarter vent assembly - 3 door.**
8. Fit headlining.  
 **INTERIOR TRIM COMPONENTS, REPAIRS, Headlining - 3 door.**
9. Fit rear body side casing.  
 **INTERIOR TRIM COMPONENTS, REPAIRS, Trim casing - body side - rear - LH.**

10. Fit rear seat.  
 **SEATS, REPAIRS, Rear seat - LH.**  
 **SEATS, REPAIRS, Rear seat - RH.**
11. Fit loadspace carpet.  
 **INTERIOR TRIM COMPONENTS, REPAIRS, Carpet - luggage compartment.**
12. Fit rear side seat belt.  
 **RESTRAINT SYSTEMS, REPAIRS, Seat belt - rear - LH.**
13. Fit rear quarter upper casing.  
 **INTERIOR TRIM COMPONENTS, REPAIRS, Trim casing - rear quarter - upper - 3 door.**
14. Fit rear quarter lower casing.  
 **INTERIOR TRIM COMPONENTS, REPAIRS, Trim casing - rear quarter - lower - 3 door.**
15. Fit tail lamp.  
 **LIGHTING, REPAIRS, Lamp assembly - tail.**
16. Fit rear roof panel finisher.  
 **EXTERIOR FITTINGS, REPAIRS, Moulding - roof - 5 door.**
17. Fit tail door aperture seal.
18. Fit soft/hard top.
19. Secure carpet to inner sill and rear heelboard.
20. Fit front door aperture seal.
21. Fit treadplate to front door aperture.
22. Fit door striker to 'B' post.
23. Fit rear wheel arch liner.
24. Fit rear bumper valance.  
 **EXTERIOR FITTINGS, REPAIRS, Bumper valance - rear.**
25. Fit sill lower finisher.  
 **EXTERIOR FITTINGS, REPAIRS, Finisher - sill - lower.**
26. Fit road wheel(s) and tighten nuts to 115 Nm (85 lbf.ft).
27. Connect all ECUs.
28. Connect alternator.
29. Connect battery earth lead.



Repair

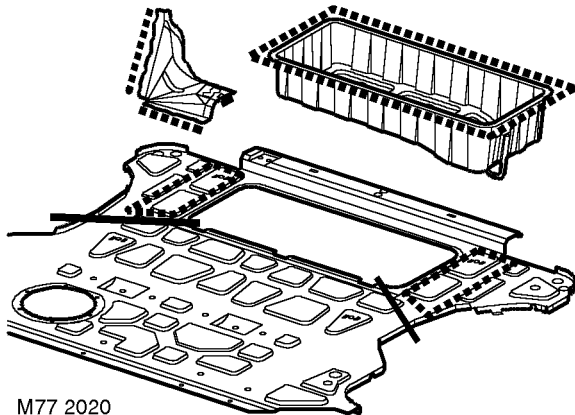

M77 2020

1. Remove existing panel(s), prepare panel joint faces and install new panel(s) in accordance with Panel Replacement Procedure. Punch or drill holes in new panel for plug welding as shown.

Refit

1. Secure vehicle harness to rear body lower closing.
2. Fit fuel tank.  
✎ **FUEL DELIVERY SYSTEM - DIESEL, REPAIRS, Tank.**
3. Fit loadspace carpet.  
✎ **INTERIOR TRIM COMPONENTS, REPAIRS, Carpet - luggage compartment.**
4. Fit LH and RH rear quarter lower casings.  
✎ **INTERIOR TRIM COMPONENTS, REPAIRS, Trim casing - rear quarter - lower - 5 door.**
5. Fit tail door aperture seal.
6. Fit tail door.  
✎ **DOORS, REPAIRS, Door - tail assembly - remove for access & refit.**
7. Fit tail exhaust pipe.  
✎ **MANIFOLDS & EXHAUST SYSTEMS - Td4, REPAIRS, Exhaust pipe - tail.**  
✎ **MANIFOLDS & EXHAUST SYSTEMS - K SERIES 1.8, REPAIRS, Exhaust pipe - tail.**  
✎ **MANIFOLDS & EXHAUST SYSTEMS - K SERIES KV6, REPAIRS, Tail pipe & silencer.**
8. Connect all ECUs.
9. Connect alternator.
10. Connect battery earth lead.

Floor longitudinal

Remove

1. Disconnect battery earth lead.
2. Disconnect alternator.
3. Disconnect all ECUs.
4. Remove tail exhaust pipe.  
✎ **MANIFOLDS & EXHAUST SYSTEMS - Td4, REPAIRS, Exhaust pipe - tail.**  
✎ **MANIFOLDS & EXHAUST SYSTEMS - K SERIES 1.8, REPAIRS, Exhaust pipe - tail.**  
✎ **MANIFOLDS & EXHAUST SYSTEMS - K SERIES KV6, REPAIRS, Tail pipe & silencer.**
5. Remove tail door.  
✎ **DOORS, REPAIRS, Door - tail assembly - remove for access & refit.**
6. Remove tail door aperture seal.
7. Remove LH and RH rear quarter lower casings.  
✎ **INTERIOR TRIM COMPONENTS, REPAIRS, Trim casing - rear quarter - lower - 5 door.**
8. Remove loadspace carpet.  
✎ **INTERIOR TRIM COMPONENTS, REPAIRS, Carpet - luggage compartment.**
9. Remove fuel tank.  
✎ **FUEL DELIVERY SYSTEM - DIESEL, REPAIRS, Tank.**
10. Release vehicle harness from rear body lower closing and position aside.

## PANEL REPAIRS

---



---

**Sill cavity wax injection holes - 5 door**

---

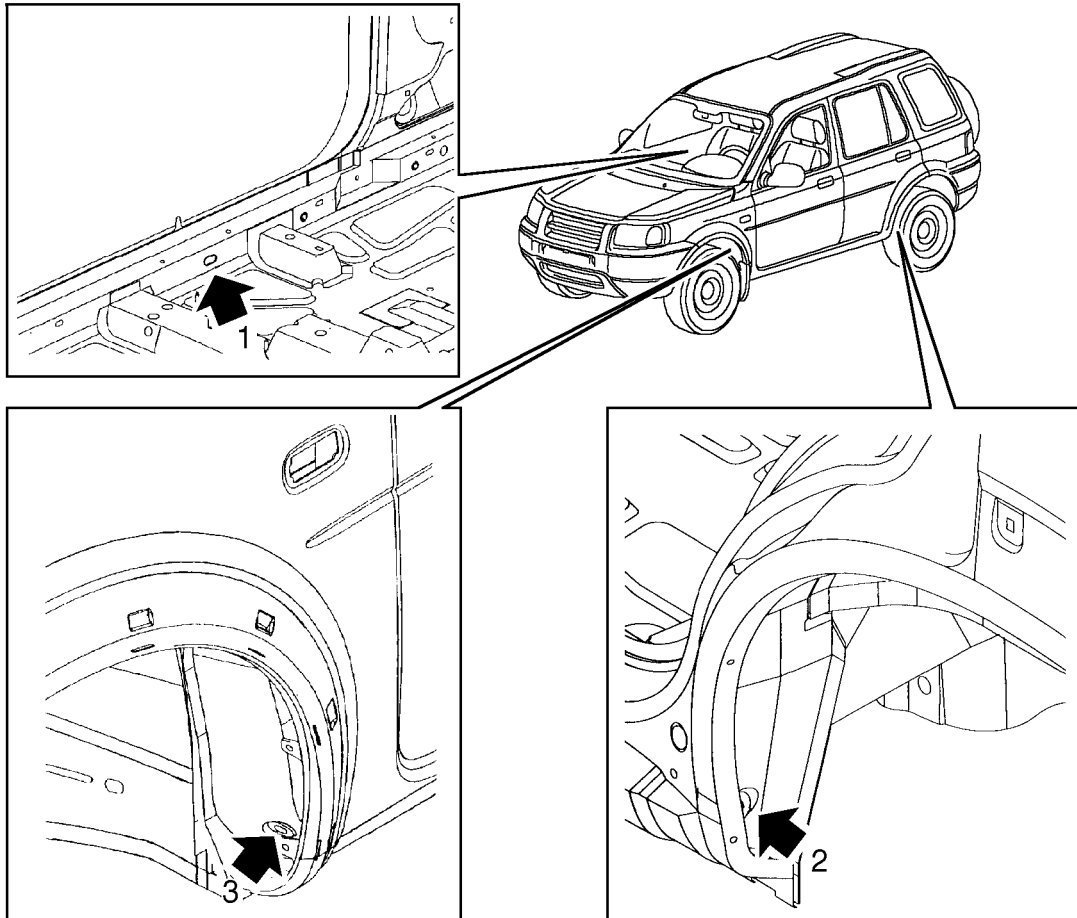

M77 1924

- 1 Injection hole for inner sill
- 2 Rear injection hole for sill
- 3 Front injection hole for sill

## CORROSION PREVENTION AND SEALING

---

### *Adhesive on rear wheel arch reinforcement - 3 door*

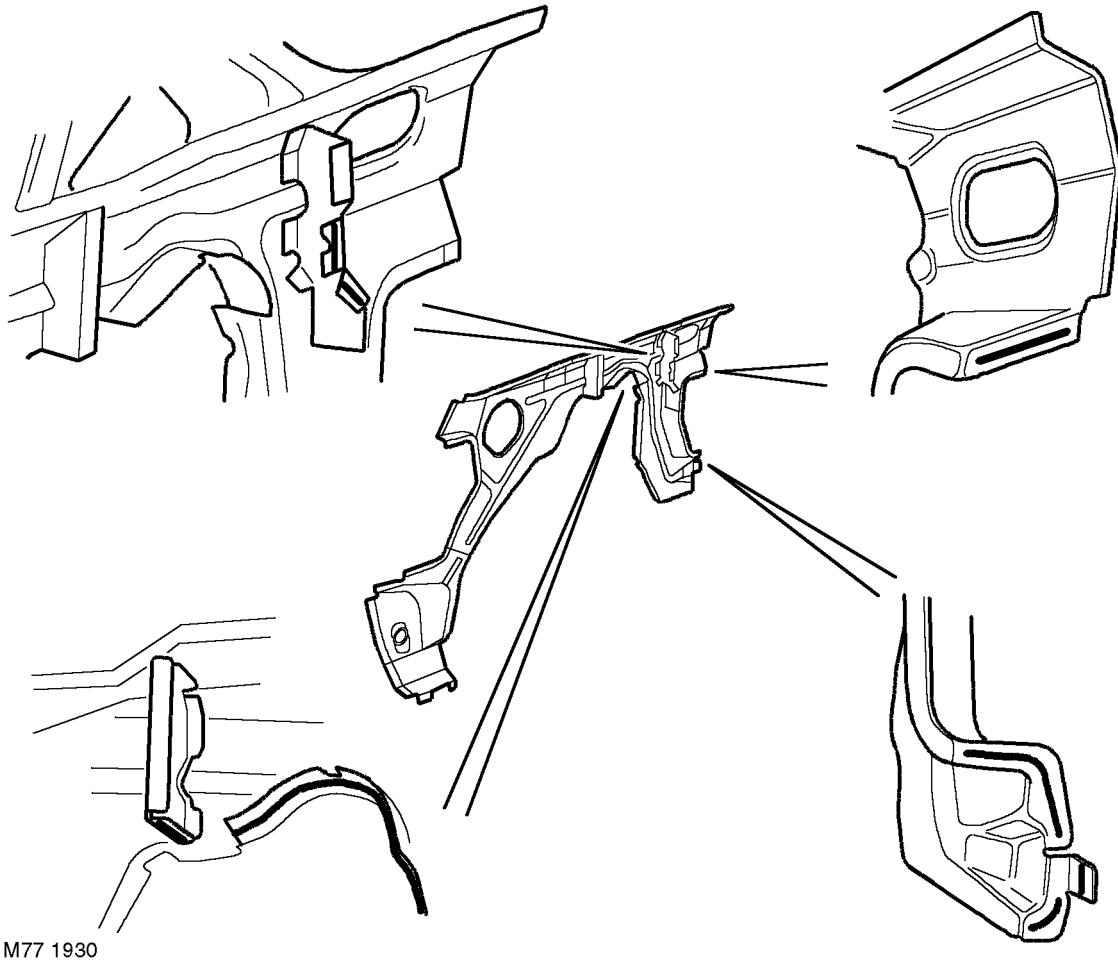

Joints symmetrically opposite to those shown are also treated. Apply 3 mm diameter beads to all joints shown.

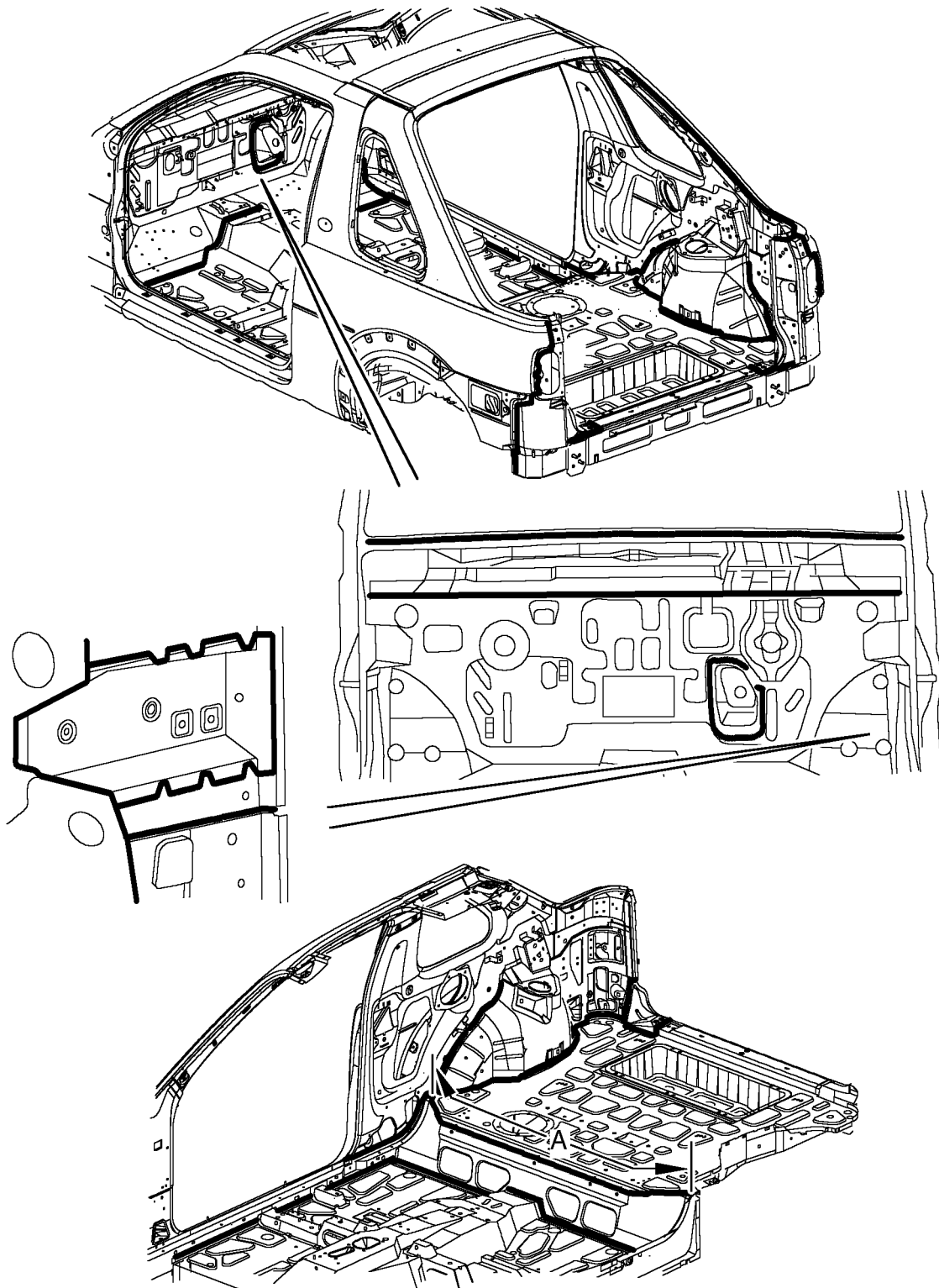
*Seam sealer on vehicle interior and rear quarter - 3 door*



M77 1940

Seams symmetrically opposite to those shown are also treated. Sealant to be wiped to a smooth finish over length 'A' (rear load floor to rear heelboard underframe).

# PAINTING

---

**Refit**

1. With assistance route PTC harness through bulkhead and fit grommets.
2. Fit clips securing PTC harness to plenum box
3. Fit air intake plenum.  
 **HEATING AND VENTILATION, REPAIRS, Plenum - air intake.**
4. Fit cable ties securing PTC harness to main bulkhead harness.
5. Connect Lucar connections to PTC element.
6. Fit air duct.
7. Fit RH demister vent duct.
8. Fit fascia.  
 **INTERIOR TRIM COMPONENTS, REPAIRS, Fascia.**
9. Connect and secure PTC harness multiplug to engine harness.
10. Secure PTC harness/relay to bulkhead bracket
11. Fit clip to secure PTC harness to ECM housing bracket.
12. Fit PTC positive leads to (80 amp) fuse holder, fit and tighten nuts to 7 Nm (5.2 lbf.ft).
13. Fit (80 amp) fuse cover.
14. Secure PTC harness/relays to ECM housing bracket.
15. Fit fuse box, ensure harness routing is clear suspension turret. Tighten nuts to 10 Nm (7 lbf.ft).
16. Fit fuse box cover.
17. Fit 'E' box housing into securing brackets.
18. Fit and tighten nut securing housing.
19. Fit harness and air duct rubber sleeve's to housing.
20. Fit harness cable tie and secure relay in housing.
21. Connect and secure joint harness and cooling fan multiplugs.
22. Connect cooling fan sensor and gearbox ECU multiplugs.
23. Fit ECM into 'E' box.  
 **ENGINE MANAGEMENT SYSTEM - EDC, REPAIRS, Engine control module (ECM).**
24. Position PTC positive cable to battery and secure with bolt, tighten to 25 Nm (18 lbf.ft).
25. Connect battery earth lead.

---

**Microswitch - positive temperature coefficient (PTC) heater - Td4 models**

---

🔑 80.20.08

**Remove**

1. Remove front console.  
 **INTERIOR TRIM COMPONENTS, REPAIRS, Console - front.**

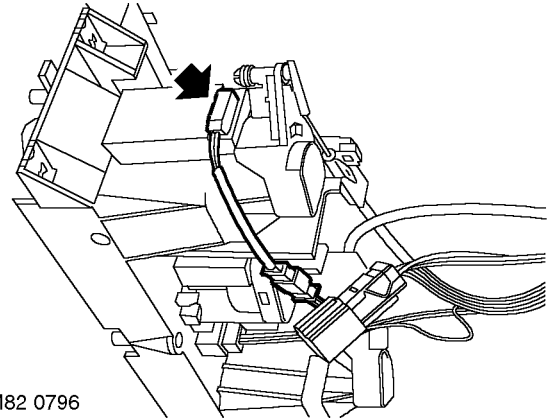

M82 0796

2. Disconnect multiplug and release microswitch from heater control pack.

**Refit**

1. Fit microswitch to heater control pack and connect multiplug.
2. Fit front console.  
 **INTERIOR TRIM COMPONENTS, REPAIRS, Console - front.**

CLICK HERE TO **DOWNLOAD** THE COMPLETE MANUAL

- Thank you very much for reading the preview of the manual.
- You can download the complete manual from: [www.heydownloads.com](http://www.heydownloads.com) by clicking the link below



- Please note: If there is no response to CLICKING the link, please download this PDF first and then click on it.

CLICK HERE TO **DOWNLOAD** THE COMPLETE MANUAL