

# WSM

---

**WORKSHOP MANUAL**  
**UTILITY VEHICLE**

**RTV-XG850**

---

**Kubota**

CLICK HERE TO **DOWNLOAD** THE COMPLETE MANUAL

- Thank you very much for reading the preview of the manual.
- You can download the complete manual from: [www.heydownloads.com](http://www.heydownloads.com) by clicking the link below



- Please note: If there is no response to **CLICKING** the link, please download this PDF first and then click on it.

CLICK HERE TO **DOWNLOAD** THE COMPLETE MANUAL

5.2.3	Removing CVT bracket and movable drive pulley .....	4-31
5.2.4	Removing CVT weight rollers .....	4-33
5.2.5	Removing CVT belt and drive pulley .....	4-34
5.2.6	Removing driven pulley .....	4-34
5.2.7	Removing CVT inside cover .....	4-35
5.2.8	Removing 4WD shaft .....	4-35
5.2.9	Removing transmission brackets .....	4-36
5.3	Disassembling transmission .....	4-36
5.3.1	Removing shift lever and differential lock lever .....	4-36
5.3.2	Removing transaxle case cover .....	4-36
5.3.3	Removing parking brake .....	4-37
5.3.4	Removing 1st shaft assembly .....	4-37
5.3.5	Removing drum shift cam .....	4-38
5.3.6	Removing 2nd shaft assembly and 3rd shaft assembly .....	4-39
5.3.7	Removing differential lock assembly .....	4-39
5.3.8	Removing DT shaft assembly .....	4-40
5.3.9	Removing 4th shaft assembly .....	4-41
6.	Servicing .....	4-42
6.1	Checking cable .....	4-42
6.2	Checking transaxle frame and rubber bushing .....	4-42
6.3	Checking CVT weight roller .....	4-43
6.4	Checking CVT spacer .....	4-43
6.5	Checking bearing .....	4-44
6.6	Checking gear .....	4-44
6.7	Checking range gear shaft and needle bearing .....	4-44
6.8	Checking backlash between differential pinion and differential side gear .....	4-44
6.9	Checking brake disk and friction plate wear .....	4-45

## 5. SUSPENSION

MECHANISM .....	5-1
1. Structure of suspension .....	5-1
SERVICING .....	5-3
1. Troubleshooting for suspension .....	5-3
2. Tightening torques for suspension .....	5-4
3. Checking and adjusting .....	5-5
3.1 Checking shock absorber .....	5-5
3.2 Adjusting shock absorber spring .....	5-5
3.3 Checking rear knuckle case .....	5-5
4. Disassembling and assembling .....	5-6
4.1 Rear shock absorber .....	5-6
4.1.1 Disconnecting negative battery cable .....	5-6
4.1.2 Removing cargo bed .....	5-6
4.1.3 Removing rear wheel .....	5-7
4.1.4 Removing rear shock absorber .....	5-7
4.2 Front shock absorber .....	5-7
4.2.1 Removing front wheel .....	5-7
4.2.2 Removing front upper cover .....	5-8
4.2.3 Removing front shock absorber .....	5-8
5. Servicing .....	5-9
5.1 Removing shock absorber spring .....	5-9

## 6. BRAKES

MECHANISM .....	6-1
1. Outline of traveling brake .....	6-1
2. Structure of traveling brake .....	6-2
2.1 Outline of automatic brake adjustment .....	6-3
3. Outline of master cylinder .....	6-4
4. Outline of brake oil .....	6-5

1. INFORMATION

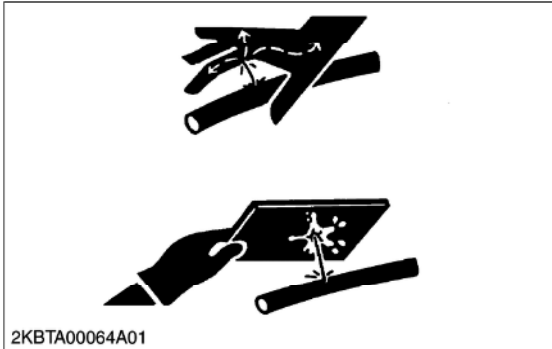

- Release residual pressure in the hydraulic circuit before removing the hydraulic components.
- Pay attention when releasing pressure in hydraulic circuit, because the machine or attachment might move unexpectedly.
- Check the coolant temperature and release the pressure before opening the radiator cap.

- Do not work immediately after stopping the engine. The engine, muffler, radiator, and hydraulic components are extremely hot.
- Do not remove caps and plugs soon after stopping the engine. The temperature and pressure of the coolant, hydraulic oil, and fuel are still high.

## 8. Avoiding hot exhaust

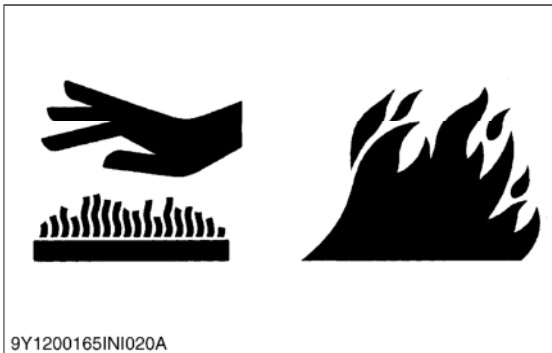

- Avoid skin exposure and contact with hot exhaust gas or components.
- Exhaust gas and components are extremely hot during operation.

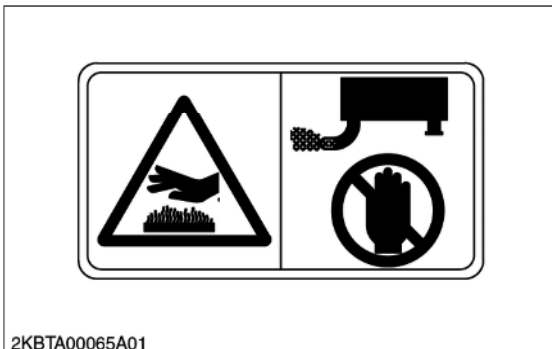

## 1. INFORMATION

Model		RTV-XG850		RTV-XG850 EVAP	
		49 states		California / AU	
		General Purpose	Worksite	General Purpose (California)	Worksite (California and AU)
Tires	Front	25×10-12 ATV 25×10-12 HDWS			
	Rear	25×10-12 ATV 25×10-12 HDWS			
Tilt steering wheel		—	Standard	—	Standard
Seat belt		3 point type			
Front guard		—	Standard	—	Standard
Glove box cover		—	Standard	—	Standard
Cargo assist gas spring		—	Standard	—	Standard
Body color		Orange	Orange/Camo/ Green/Black/ Desert sand	Orange	Orange/Camo/ Green/Black/ Desert sand

\*1 Measured by manufacturer

### NOTE

- The company reserves the right to change the specifications without notice.
- The values in “Ground clearance” and “Weight” are those of the machine equipped with the tires in the table above.

# HANDLING PRECAUTIONS FOR ELECTRICAL PARTS AND WIRING

**IMPORTANT**

- Check electrical wiring for damage and loosened connection every year. To this end, educate the customer to do his or her own check and at the same time recommend the dealer to perform periodic check for a fee.
- Do not try to modify or remodel any electrical parts and wiring.
- When removing the battery cables, disconnect the negative cable first. When installing the battery cables, connect the positive cable first.

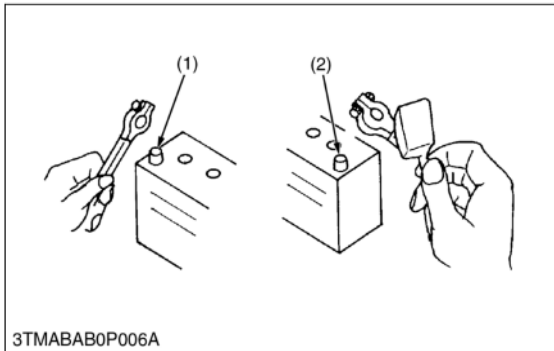

(1) Negative terminal (2) Positive terminal

To ensure safety and prevent damage to the machine and surrounding equipment, heed the following precautions in handling electrical parts and wiring.

## 1. Handling of wiring

- Securely tighten wiring terminals.

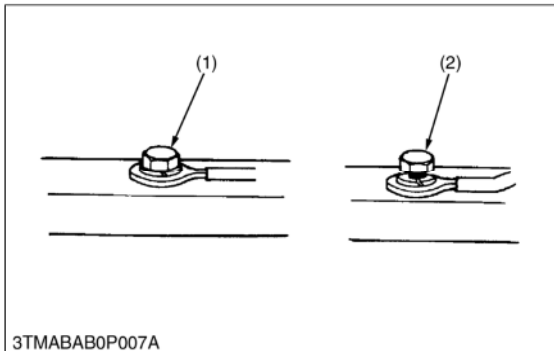

(1) Correct (Securely tighten) (2) Incorrect (Loosening leads to damaged contact)

- Do not let wiring contact dangerous part.

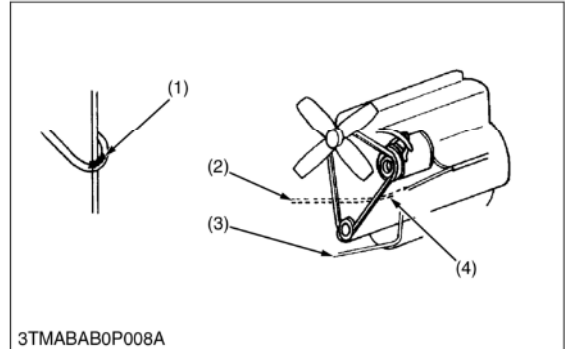

3TMABAB0P008A

(1) Dangerous part (Sharp edge) (2) Wiring (Incorrect)  
 (3) Wiring (Correct) (4) Dangerous part

- Repair or change torn or aged wiring immediately.

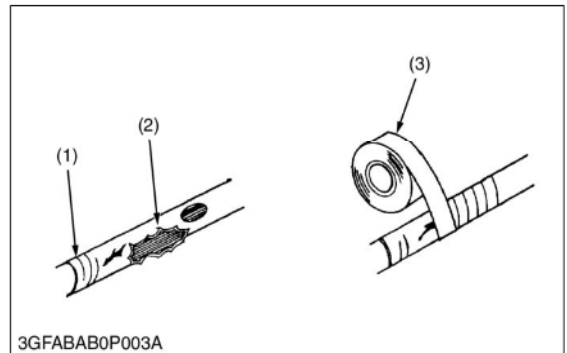

3GFABAB0P003A

(1) Aged (2) Torn (3) Electrical tape

- Securely insert grommet.

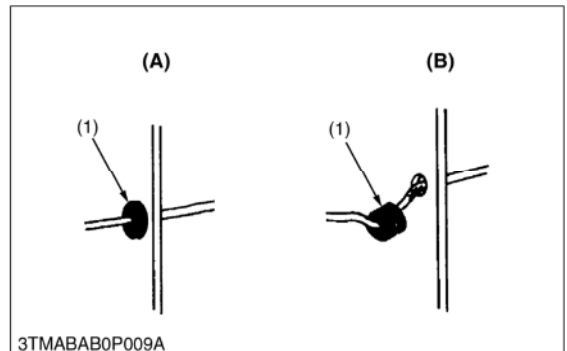



3TMABAB0P009A



(1) Grommet (A) Correct (B) Incorrect

- Securely clamp, being careful not to damage wiring.

## 7. American standard screws, bolts and nuts with UNC or UNF threads

Grade	 SAE GR.5			 SAE GR.8		
	Unit	N · m	kgf · m	lbf · ft	N · m	kgf · m
1/4	11.7 to 15.7	1.20 to 1.60	8.63 to 11.5	16.3 to 19.7	1.67 to 2.00	12.0 to 14.6
5/16	23.1 to 27.7	2.36 to 2.82	17.0 to 20.5	33 to 39	3.4 to 3.9	25 to 28
3/8	48 to 56	4.9 to 5.7	36 to 41	61 to 73	6.3 to 7.4	45 to 53
1/2	110 to 130	11.3 to 13.2	81.2 to 95.8	150 to 178	15.3 to 18.1	111 to 131
9/16	150 to 178	15.3 to 18.1	111 to 131	217 to 260	22.2 to 26.5	160 to 191
5/8	204 to 244	20.8 to 24.8	151 to 179	299 to 357	30.5 to 36.4	221 to 263

## 8. Plugs

Shape	Size	Material of opponent part					
		Ordinariness			Aluminum		
		N · m	kgf · m	lbf · ft	N · m	kgf · m	lbf · ft
Tapered screw 	R1/8	13 to 21	1.3 to 2.2	9.4 to 15	13 to 19	1.3 to 2.0	9.4 to 14
	R1/4	25 to 44	2.5 to 4.5	18 to 32	25 to 34	2.5 to 3.5	18 to 25
	R3/8	49 to 88	5.0 to 9.0	37 to 65	49 to 58	5.0 to 6.0	37 to 43
	R1/2	58.9 to 107	6.00 to 11.0	43.4 to 79.5	59 to 78	6.0 to 8.0	44 to 57
Straight screw 	G1/4	25 to 34	2.5 to 3.5	18 to 25	—	—	—
	G3/8	62 to 82	6.3 to 8.4	46 to 60	—	—	—
	G1/2	49 to 88	5.0 to 9.0	37 to 65	—	—	—

- For your safety we strongly recommend **KUBOTA DOT3 GENUINE BRAKE FLUID** from a sealed container. Using other type of oil damages synthetic resin or rubber installed in brake system components, and may cause brake failure.
- Avoid contamination of the brake fluid. Thoroughly clean area around the filler cap before removing. Do not open the brake fluid reservoir cap unless absolutely necessary.
- Use extreme care when filling the reservoir. If brake fluid is spilled on the power steering hose, wash off with water immediately. Brake fluid quickly damages synthetic resin or rubber hoses.

1. Park the vehicle on a level surface.
2. Open the hood.
3. Check to see that the brake fluid level is between the **[MAX]** and **[MIN]** marks.
4. If it is below the **[MIN]** mark, add brake fluid to the **[MAX]** mark.

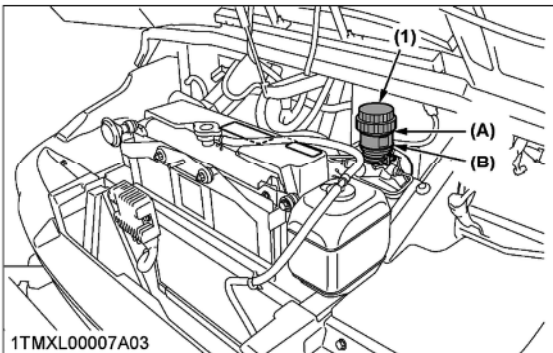

(1) Oil tank  
(A) [MAX]  
(B) [MIN]

### 1.10 Checking brake pedal

#### **WARNING**

To avoid serious injury or death:

- Stop the engine and chock the wheels before checking brake pedal.

1. Inspect the brake pedals for free travel, and smooth operation.
2. Adjust if incorrect measurement is found.

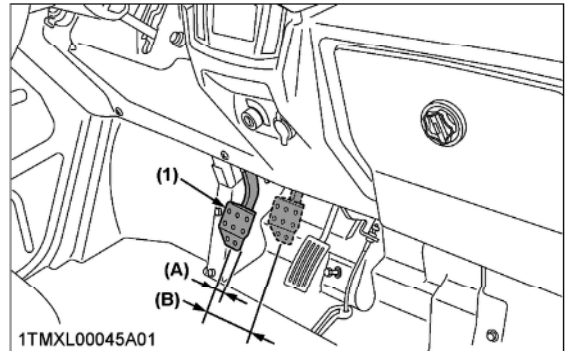

(1) Brake pedal  
(A) "FREE TRAVEL"  
(B) "PEDAL STROKE"

### 1.11 Checking parking brake

Pull the parking brake lever to apply the brakes. With the key switch at "ON" position, the parking brake indicator on the instrument panel lights up. To release the brakes, push in the button at the side of the parking brake lever and tilt the lever forward.

#### ■ NOTE

- Make sure the parking brake warning lamp (P) on the Easy Checker™ goes off when parking brake lever is forward.

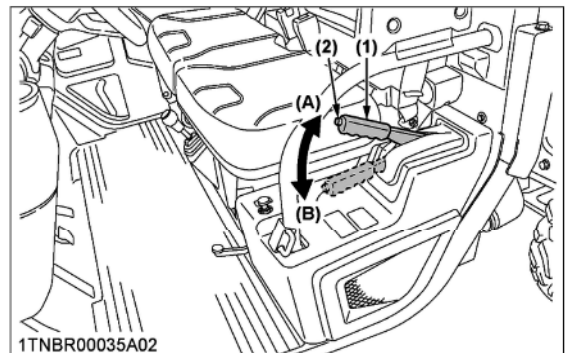

(1) Parking brake lever  
(2) Release button  
(A) "PULL"  
(B) "RELEASE"

### 1.12 Checking Easy Checker™

1. Inspect the instrument panel for broken Easy Checker™ lamps.

### 1.13 Checking head light, and so on

1. Inspect the lights for broken bulbs and lenses.
2. Replace if broken.

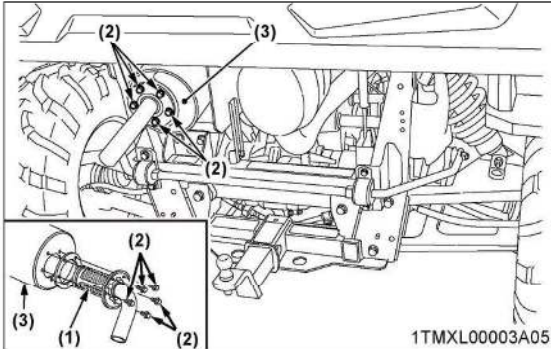

(1) Spark arrester  
(2) Bolt

(3) Muffler

### 3.9 Checking exhaust system

Check exhaust system parts (muffler, pipe, gasket) for failures such as cracks and deformation.

If necessary, replace faulty part. If you do not know the failure, check the exhaust line.

### 3.10 Checking CVT belt

Have your CVT belt checked when:

- Rubber burning smell.
- Engine speed increases even at the same vehicle speed.

#### ■ IMPORTANT

- Avoid the hard use method shown below so that the CVT belt does not get premature wear and damage:
  - When travelling in a place with extremely dusty conditions.
  - When driving continues while belt slip (the engine speed increases even at the same vehicle speed).
  - When going deeper into mud or water than recommended.
  - To climb, to carry a heavy load, to tow, to use the high range in these cases.
  - When exceeding the maximum load capacity or tow load.
  - When extremely cold, loading the engine without warmup.

— RELATED PAGE —

[4.5 Checking CVT belt on page 4-16](#)

### 3.11 Checking the transmission gear shift sensor

1. Confirm that the range gear shift position is properly displayed on the LCD panel.
2. If the range gear shift position is not displayed correctly on the LCD panel, refer to "Disconnecting transmission wire harness."

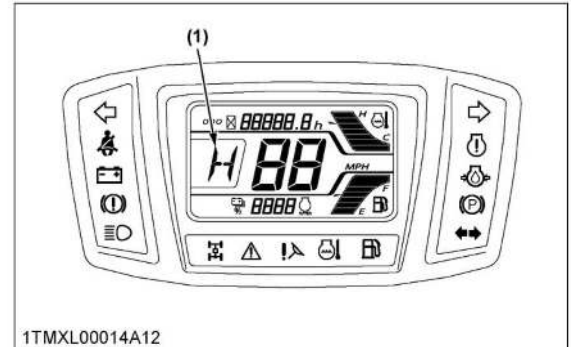

(1) Range gear shift position

— RELATED PAGE —

[7.1.20 Disconnecting transmission wire harness on page 3-56](#)

### 3.12 Checking carbon canister air filter (California only)

1. Remove the push rivets and rubber sheet.

#### ■ NOTE

- To remove the push rivet:
  1. Push the pin to unlock.
  2. Remove the push rivet.
- To install the push rivet:
  3. Push the pin to ready to install.
  4. Install the push rivet into the hole.
  5. Push the pin to lock.

See the following figures.

**California only**

3. Remove the push rivets and rubber sheet.

■ **NOTE**

- To remove the push rivet:
  1. Push the pin to unlock.
  2. Remove the push rivet.
- To install the push rivet:
  3. Push the pin to ready to install.
  4. Install the push rivet into the hole.
  5. Push the pin to lock.

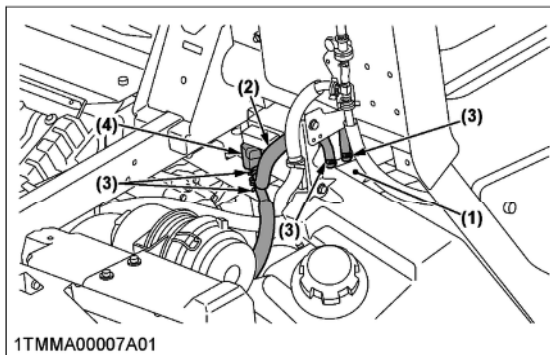
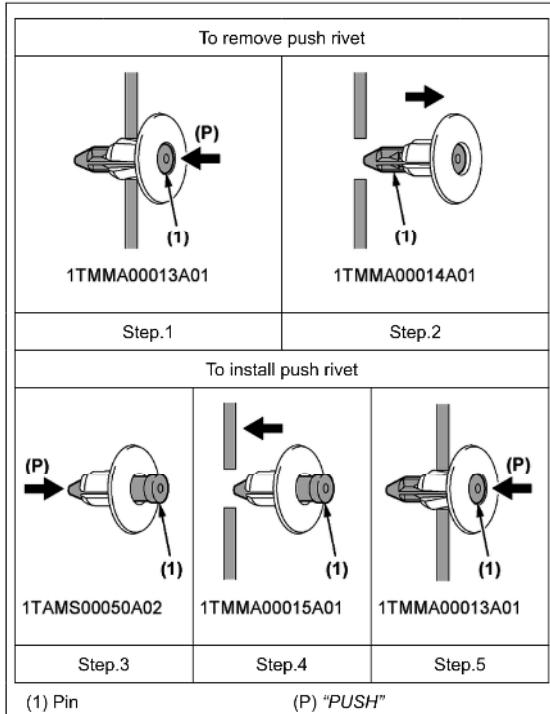

- (1) Carbon canister
- (2) Fuel line
- (3) Pipe clamp
- (4) Purge valve

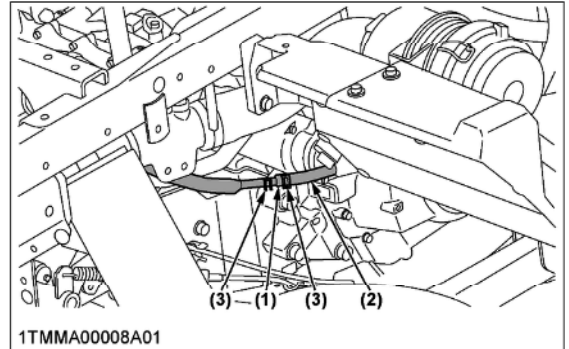

- (1) Connector
- (2) Fuel line
- (3) Pipe clamp

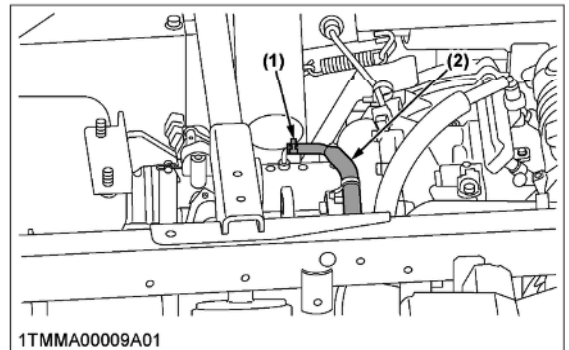

- (1) Pipe clamp
- (2) Fuel line

## 9.2 Checking radiator hose, pipe and clamp

Park the vehicle on a flat surface. Raise the cargo bed and mount the safety support.

Check to see if radiator hoses are properly fixed.

1. If hose clamps are loose or water leaks, tighten bands securely.
2. Replace hoses and tighten hose clamps securely, if radiator hoses are swollen, hardened or cracked.

7. Connect the negative battery cable.

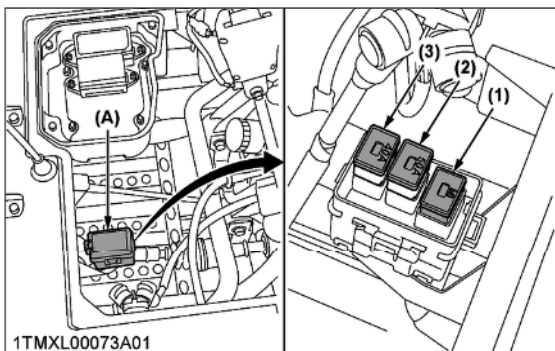

1TMXL00073A01  
(1) Slow-blow fuse (A) Fuse box  
(2) Slow-blow fuse  
(3) Slow-blow fuse

Slow-blow fuse no.	Capacity (A)	Protected circuit
1	60	Check circuit against wrong battery connection
2	50	Dynamo
3	40	EPS (BAT)

### 12.3 Replacing light bulb

- Turn signal light (front)  
Take the bulb out of the light body and replace it with a new one.
- Other lights  
Detach the lens and replace the bulb.

Light	Capacity
Tail light	5 W
Brake light	21 W
Turn signal light (front)	21 W (if equipped)
Turn signal light (rear)	21 W (if equipped)
Work light (rear)	27 W (if equipped)

### 12.4 Replacing fuel filter

#### WARNING

To avoid serious injury or death:

- Be sure to stop the engine before changing the fuel filter.
- Allow engine to cool down sufficiently, oil can be hot and can burn.

1. Park the vehicle on a flat surface.
2. Stop the engine.
3. Remove the tank cover (1).

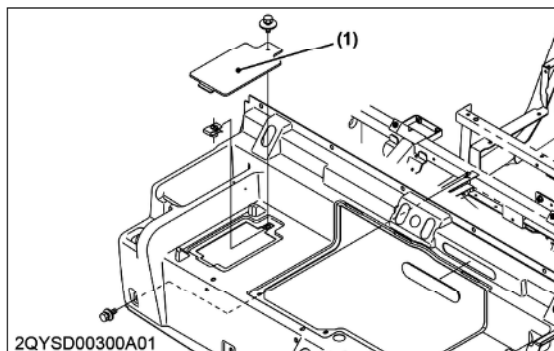

2QYSD00300A01  
(1) Tank cover

4. Remove the fuel pump (3).
5. Remove the fuel filter (5).

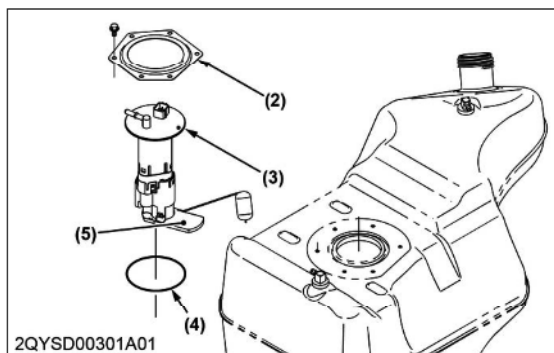

2QYSD00301A01  
(2) Plate (5) Fuel filter  
(3) Fuel pump  
(4) O-ring

#### ■ IMPORTANT

- Replace the O-ring (4) with a new one.

— RELATED PAGE —  
[3.12.18 Checking fuel pump on page 9-41](#)

## 1.7 Timing chain holder

Use for disassembling and assembling timing chain.

■ **NOTE**

- This special tool is not provided, so make it referring to the figure.

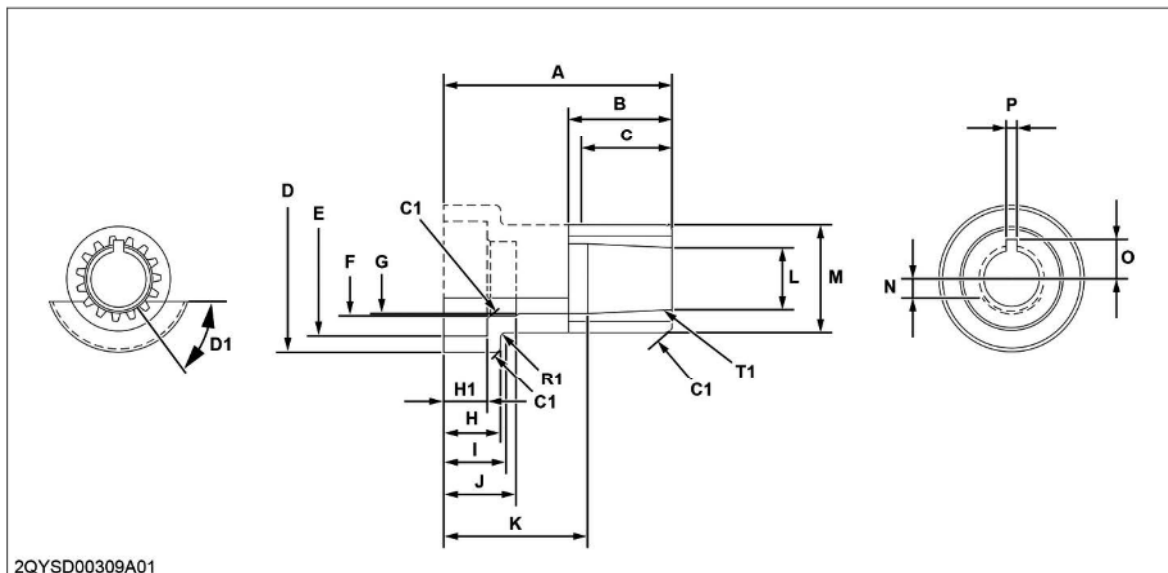

A	89 mm (3.5 in.)
B	40.5 mm (1.59 in.)
C	35 mm (1.4 in.)
D	56 mm dia. (2.2 in. dia.)
E	41 mm dia. (1.6 in. dia.)
F	26 mm dia. (1.0 in. dia.)
G	25 mm dia. (0.98 in. dia.)
H	22 mm (0.87 in.)
I	24 mm (0.87 in.)
J	28 mm (1.1 in.)
K	56 mm (2.2 in.)
L	21.703 mm dia. (0.85445 in. dia.)
M	40 mm (1.6 in.)
N	8 mm (0.3 in.)
O	15 mm (0.59 in.)
P	4.2 mm (0.17 in.)
C1	1 mm (0.04 in.)
D1	0.94 rad (54°)
H1	17 mm (0.67 in.)
R1	2 mm (0.08 in.)
T1	Taper 1/10

# 3. ENGINE

### 3. ENGINE

#### 3.3 Function of water pump

The function of the water pump is to circulate coolant through the engine and radiator to keep the engine within operating temperature.



(1) Impeller

The water pump is chain driven by the crankshaft. The water from the radiator is sucked in through the center of the impeller (1) that rotates at a high speed. The water is then accelerated by the centrifugal force and fed into the water jacket of the cylinder.

A special mechanical seal effective against water and heat is installed between the bearing and the pump house to prevent a leakage of coolant.



2QYSD00069A02

#### 3.4 Function of thermostat

The function of the thermostat is to allow coolant over a certain temperature to circulate back through the radiator for cooling and reuse.

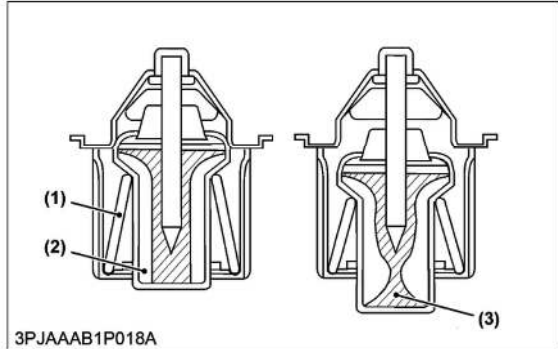

(1) Spring  
(2) Wax

(3) Synthetic rubber

This wax pellet type thermostat changes the flow of coolant according to temperatures so as to prevent the engine from being over-cooled.

When the water temperature reaches 69 to 73 °C (156 to 163 °F), the valve starts to open gradually and opens fully at 84 °C (183 °F). When the water temperature is less than 69 °C (156 °F), the valve close and the water enters the water pump through the return pipe and circulate in the engine. At the water temperature 69 °C (156 °F) or higher, the wax expands when it changes to a liquid from a solid and forces down the pellet to open the valves. As a result, the water cooled by the radiator enters the engine through the thermostat.

#### 3.5 Function of radiator

The function of the radiator is to cool the hot coolant after it is circulated through the engine.

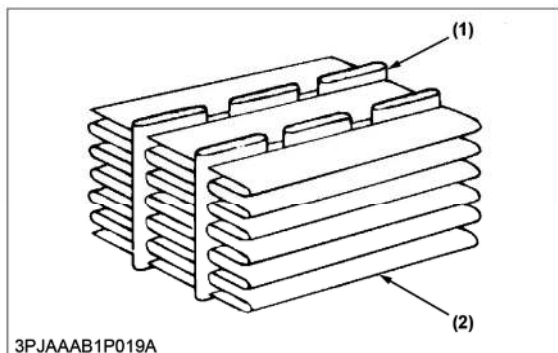

(1) Tube

(2) Radiation plate

The radiator consists of an upper tank, lower tank, and the core that connects them. The core has many passages (tubes) through which water flows to the



## 3. ENGINE

## Disassembling engine

Item	Dimension × Length	N · m	kgf · m	lbf · ft
Exhaust pipe flange nut	M8	18.0 to 20.0	1.84 to 2.03	13.3 to 14.7
Intake pipe flange nut	M8	20 to 24	2.1 to 2.4	15 to 17
Thermostat cover flange bolt	M6 × 20	9.0 to 11	0.92 to 1.1	6.7 to 8.1
Clutch case assembly flange bolt	M8 × 25	22.0 to 24.0	2.25 to 2.44	16.3 to 17.7
Centrifugal clutch lock nut	M20	170 to 190	17.4 to 19.3	126 to 140
Oil filter	—	11.7 to 15.7	1.20 to 1.60	8.63 to 11.5
Oil pipe gauge flange bolt	M6 × 12	9.0 to 11	0.92 to 1.1	6.7 to 8.1
Water pump cover flange bolt	M6 × 45 M6 × 65	9.0 to 11	0.92 to 1.1	6.7 to 8.1
Impeller	M6	9.0 to 11	0.92 to 1.1	6.7 to 8.1
Water pump case flange bolt	M6 × 20	9.0 to 11	0.92 to 1.1	6.7 to 8.1
Adapter flange bolt	M6 × 20	9.0 to 11	0.92 to 1.1	6.7 to 8.1
Magneto cover flange bolt	M6 × 30	9.0 to 11	0.92 to 1.1	6.7 to 8.1
Flywheel flange nut	M20	160 to 180	16.4 to 18.3	118 to 132
Ignition coil flange bolt	M6 × 20	9.0 to 11	0.92 to 1.1	6.7 to 8.1
Spark plug	—	10 to 12	1.1 to 1.2	7.4 to 8.8
Head cover bolt	—	9.0 to 11	0.92 to 1.1	6.7 to 8.1
Guide stopper flange bolt	M6 × 20	9.0 to 11	0.92 to 1.1	6.7 to 8.1
Timing chain tensioner flange bolt	M6 × 25	9.0 to 11	0.92 to 1.1	6.7 to 8.1
Timing chain tensioner flange bolt	M6 × 8	4.5 to 6.0	0.46 to 0.61	3.4 to 4.4
Cam support flange bolt	M6 × 40	9.0 to 11	0.92 to 1.1	6.7 to 8.1
Cam cap flange bolt	M6 × 40	9.0 to 11	0.92 to 1.1	6.7 to 8.1
Cylinder head flange bolt	M6 × 30	9.0 to 11	0.92 to 1.1	6.7 to 8.1
Cylinder head bolt and washer assembly	M11 × 191	—	—	—
Timing chain lever flange bolt	M6 × 20	9.0 to 11	0.92 to 1.1	6.7 to 8.1
Stopper plate flange bolt	M6 × 20	9.0 to 11	0.92 to 1.1	6.7 to 8.1
Water pump shaft plate flange bolt	M6 × 12	9.0 to 11	0.92 to 1.1	6.7 to 8.1
Starter assembly flange bolt	M6 × 25	9.0 to 11	0.92 to 1.1	6.7 to 8.1
Oil pan flange bolt	M6 × 25	9.0 to 11	0.92 to 1.1	6.7 to 8.1
Chain guide bolt and washer assembly	—	6.0 to 8.0	0.62 to 0.81	4.5 to 5.9
Oil pump flange bolt	M6 × 60 M6 × 40	9.0 to 11	0.92 to 1.1	6.7 to 8.1
Pivot bolt	M8 × 22.5	13.5 to 16.5	1.38 to 1.68	9.96 to 12.1
Lower crankcase flange bolt	M6 × 40	9.0 to 11	0.92 to 1.1	6.7 to 8.1

(Continued)

6. Refer to the "Intake valve shim guide" for service specifications.

**(When reassembling)**

- Install the shim (10) into the center of the valve spring retainer (11), then install the valve lifter (9).
- Before installing the intake cam cap and cam support, rotate the crankshaft so the magneto side piston is at T.D.C. After T.D.C. is set, continue to turn crankshaft 1.6 rad (90°) in the clockwise direction.  
The purpose of this is to make sure the cam lobes are not contacting the valve lifters when the intake cam cap and cam support are installed.
- Install the intake cam cap (4) in the original position so the word **[CHAIN]** is pointing in the direction of the timing chain.
- Install the timing chain tensioner lock (2) before installing the tensioner. After tightening the flange bolts, pull out the timing chain tensioner lock.
- Rotate the crankshaft until the magneto side piston is at T.D.C.
- Make sure the **[E]** on the exhaust cam (6) and **[I]** on the intake cam (7) are lined up with the top of the cylinder head.

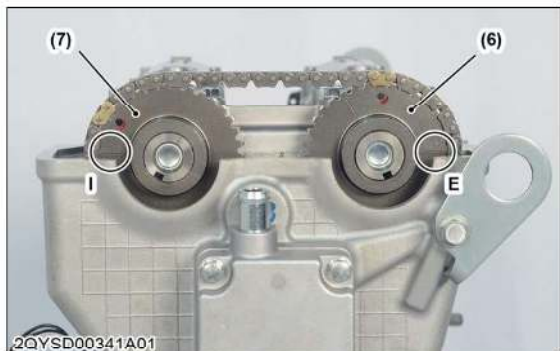

(6) Exhaust cam (7) Intake cam

- Check the valve clearance according to "Checking valve clearance".

Tightening torque	Cam cap flange bolt	9.0 to 11 N·m 0.92 to 1.1 kgf·m
	Cam support flange bolt	6.7 to 8.1 lbf·ft

— RELATED PAGE —

- 5.6 [Checking valve clearance on page 2-39](#)
- 5. [Intake valve shim guide on page 3-34](#)

## 6.2 Lubricating system

### 6.2.1 Checking oil pressure

**Tools required**

- Oil pressure tester
1. Lift the seat to the upright position.
  2. Remove the center box cover (1).



(1) Center box cover

3. Remove the lower center cover (2).



(2) Lower center cover

4. Remove the engine oil pressure switch (3).



(3) Oil pressure switch

5. Install the oil pressure tester.

Tightening torque	Switch cover plate bolt	3.0 to 4.0 N·m 0.31 to 0.40 kgf·m 2.3 to 2.9 lbf·ft
-------------------	-------------------------	---

### 7.1.9 Removing center box cover and lower center cover

1. Remove the center box cover (1).



(1) Center box cover

2. Remove the lower center cover (2).



(2) Lower center cover



(1) Muffler cover (2) Front exhaust cover (3) Middle exhaust cover

#### (When reassembling)

- Apply bond to 4 flange bolt (4) locations.

### 7.1.10 Removing exhaust covers

#### Tools required

- Resbond 907TS blue

1. Remove the muffler cover (1).
2. Remove the front exhaust cover (2).
3. Remove the middle exhaust cover (3).

### 3. ENGINE

### SERVICING 7. Disassembling and assembling

7. Remove the drive pulley boss (9) from the outer clutch shaft (7) if it was not removed with the movable drive pulley.



2QYSD00399A01

(9) Drive pulley boss

#### (When reassembling)

1. Install the drive pulley boss (9) into the movable drive pulley (5).
2. Squeeze the CVT belt (10) by hand at locations (P1) and (P2). This will cause a gap (G) between the front of the CVT belt and the outer clutch shaft. While squeezing the belt, install the movable drive pulley (5), drive pulley plate (6) and drive pulley boss (9) as an assembly onto the outer clutch shaft (7).

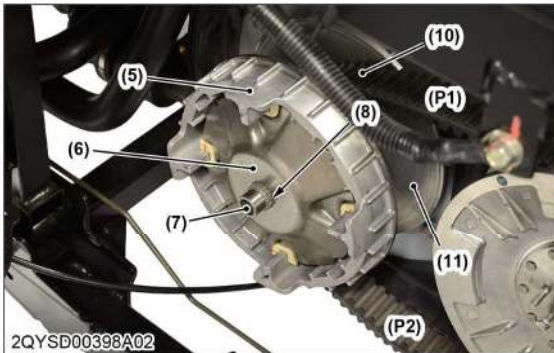

2QYSD00398A02

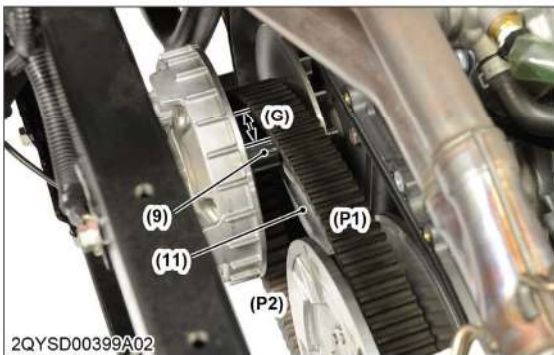

2QYSD00399A02

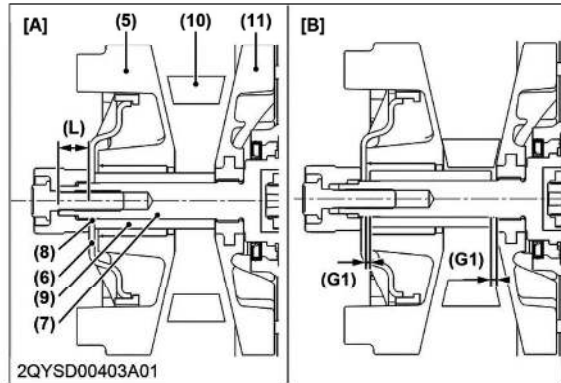

2QYSD00403A01

- |   |  |
|---|--|
| (5) Movable drive pulley  | (G) Gap  |
| (6) Drive pulley plate  | (G1) Gap at the both ends of the drive pulley boss |
| (7) Outer clutch shaft  | (P1) Upper CVT belt squeeze position               |
| (8) Splines   | (P2) Lower CVT belt squeeze position               |
| (9) Drive pulley boss   |  |
| (10) CVT belt   |  |
| (11) Drive pulley   |  |
| (L) The length between the end of drive pulley plate and outer clutch shaft | [A] Correct  |
|   | [B] Incorrect                                      |

3. Make sure the length (L) between the end of outer clutch shaft (7) and drive pulley plate (6).

#### ■ IMPORTANT

- Do not make a gap (G1) at the both ends of drive pulley boss (9).
- The both ends of drive pulley boss (9) must be in contact with drive pulley plate (6) and drive pulley (11) firmly.
- Make sure the CVT belt is not pinched between the movable drive pulley and drive pulley. This can cause damage to the CVT components.
- If gap (G1) exists at the both ends of the drive pulley boss, it will play freely while traveling. Free play causes premature wearing of the splines (8).

Length (L)	Service specification	18.4 to 19.6 mm 0.725 to 0.771 in.
------------	-----------------------	---------------------------------------

4. Install the CVT bracket (2) with flange nuts and bolts (4). Rotate the movable drive pulley clockwise to make sure all components move freely. Tighten to the specified torque from (A) to (D) in the sequence shown.

3. ENGINE

3. Remove the reduction gear (3) and shaft (4).

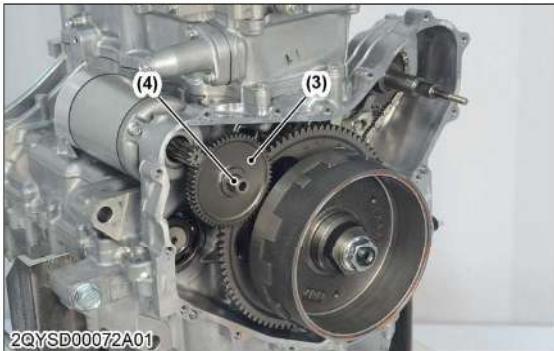

(3) Reduction gear (4) Shaft

(When reassembling)

- Apply grease to the outside of the shaft (4) and to the teeth of reduction gear (3).
- Apply liquid gasket (Three Bond 1215 or equivalent) to the mating surface areas (M) shown in the figure.

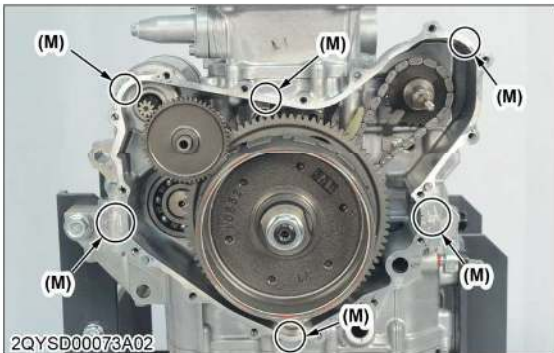

(M) Mating surface area

- Replace the magneto cover gasket with a new one.
- Tighten the flange bolts (1) in the sequence shown in the figure.

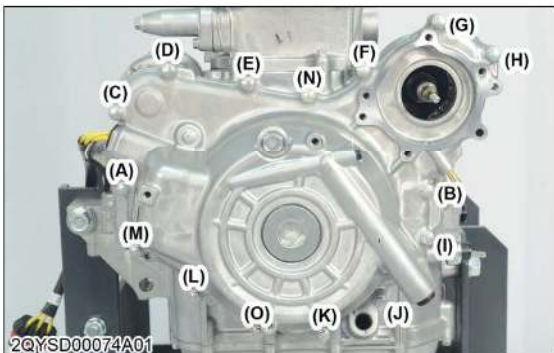

Tightening torque	Magneto cover flange bolt	9.0 to 11 N·m 0.92 to 1.1 kgf·m 6.7 to 8.1 lbf·ft
-------------------	---------------------------	---

7.3.8 Removing flywheel and starting gear

1. Install the centrifugal clutch onto the crankshaft and loosely install the lock nut.
2. Install the clutch holder (1) onto the centrifugal clutch.
3. Secure the clutch holder and remove the flange nut (4) and washer.



(1) Clutch holder (4) Flange nut

4. Install the flywheel puller (5) onto the flywheel as shown in the figure.
5. Remove the flywheel (7) and starting gear (6) as an assembly.



(5) Flywheel puller (7) Flywheel  
(6) Starting gear

(When reassembling)

- Degrease the tapered part (B) of the crankshaft (8).
- Degrease the tapered part of the flywheel (7).
- Apply engine oil to the straight part (C) and threaded part (A) of the crankshaft.

CLICK HERE TO **DOWNLOAD** THE COMPLETE MANUAL

- Thank you very much for reading the preview of the manual.
- You can download the complete manual from: [www.heydownloads.com](http://www.heydownloads.com) by clicking the link below



- Please note: If there is no response to **CLICKING** the link, please download this PDF first and then click on it.

CLICK HERE TO **DOWNLOAD** THE COMPLETE MANUAL

**Tightening sequence**

Step	Action	Specification	Sequence
1	Tighten	35 N·m 3.6 kgf·m 26 lbf·ft	From (A) to (F)
2	Loosen	180° 3.14 rad	From (F) to (A)
3	Tighten	35 N·m 3.6 kgf·m 26 lbf·ft	From (A) to (F)
4	Loosen	180° 3.14 rad	From (A) to (B)
5	Tighten	17 N·m 1.7 kgf·m 13 lbf·ft	From (A) to (B)
6	Tighten	60° 1.0 rad	From (A) to (B)
7	Loosen	180° 3.14 rad	From (F) to (C)
8	Tighten	17 N·m 1.7 kgf·m 13 lbf·ft	From (C) to (F)
9	Tighten	60° 1.0 rad	From (C) to (F)
10	Tighten	20 N·m 2.0 kgf·m 15 lbf·ft	From (G) to (H)

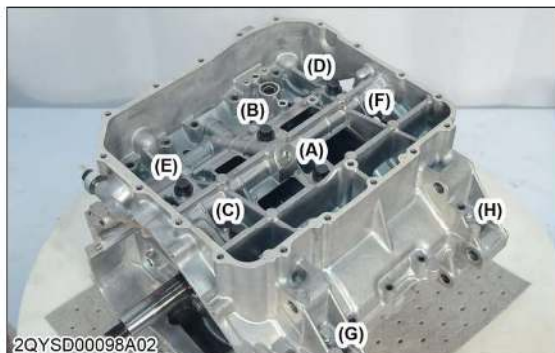

7. Tighten flange bolts (2).
8. Tighten flange bolts (1).

Tightening torque	Lower crankcase flange bolt (M6 × 40)	9.0 to 11 N·m 0.92 to 1.1 kgf·m 6.7 to 8.1 lbf·ft
	Lower crankcase flange bolt (M6 × 75)	
	Lower crankcase flange bolt (M8 × 50)	20 N·m 2.0 kgf·m 15 lbf·ft
	Lower crankcase flange bolt (M10 × 110)	See tightening sequence table

**7.3.19 Removing balancer shaft**

1. Remove the balancer shaft (1) from the lower crankcase.



(1) Balancer shaft

**(When reassembling)**

- Line up the timing marks (A) on the balancer shaft (1) and crankshaft (2) as shown in the figure.



(1) Balancer shaft  
(2) Crankshaft  
(A) Timing marks

**7.3.20 Removing crankshaft**

1. Remove the connecting rod bolts (1).
2. Remove the connecting rod caps (2).

### 3. ENGINE

3. After locating the crankcase and crankshaft codes, use the (J1) and (J3) bearing reference table and (J2) bearing reference table shown below to determine the replacement bearings for (J1), (J2), and (J3). For example, as shown in the above illustrations the bearing for the (J1) and (J3) locations based on etchings **[BCB]** on the crankcase and **[BBB]** on the crankshaft would be "4: Green 23E1600413" as shown below. The bearing for the (J2) location based on the etchings would be "5: Yellow 23E1620503".

#### (J1) and (J3) bearing

Crankshaft journal O.D.	Crankcase journal O.D.		
	A (50.018 to 50.012 mm)	B (50.012 to 50.006 mm)	C (50.006 to 50.000 mm)
<b>A</b> (45.002 to 44.996 mm)	4: Green 23E1600413	5: Yellow 23E1600513	6: Pink 23E1600613
<b>B</b> (44.996 to 44.990 mm)	3: Brown 23E1600313	4: Green 23E1600413	5: Yellow 23E1600513
<b>C</b> (44.990 to 44.984 mm)	2: Black 23E1600213	3: Brown 23E1600313	4: Green 23E1600413
<b>D</b> (44.984 to 44.978 mm)	1: Blue 23E1600113	2: Black 23E1600213	3: Brown 23E1600313

#### (J2) bearing

Crankshaft journal O.D.	Crankcase journal O.D.		
	A (50.018 to 50.012 mm)	B (50.012 to 50.006 mm)	C (50.006 to 50.000 mm)
<b>A</b> (45.008 to 45.002 mm)	4: Green 23E1620403	5: Yellow 23E1620503	6: Pink 23E1620603
<b>B</b> (45.002 to 44.996 mm)	3: Brown 23E1620303	4: Green 23E1620403	5: Yellow 23E1620503
<b>C</b> (44.996 to 44.990 mm)	2: Black 23E1620203	3: Brown 23E1620303	4: Green 23E1620403
<b>D</b> (44.990 to 44.984 mm)	1: Blue 23E1620103	2: Black 23E1620203	3: Brown 23E1620303

**used together. These special codes are needed when replacing connecting rod bearings.**

1. Make note of the two digit numerical code etched into the crankshaft web. For example, in the illustration shown below, the two digit code is **[11]**. This means **[1]** is the classification for location (P1) on the crankshaft, **[1]** is the classification for location (P2) on the crankshaft.

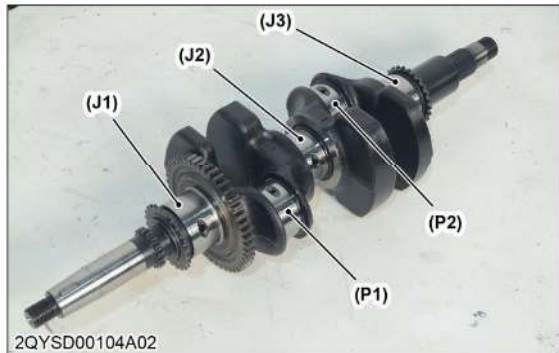
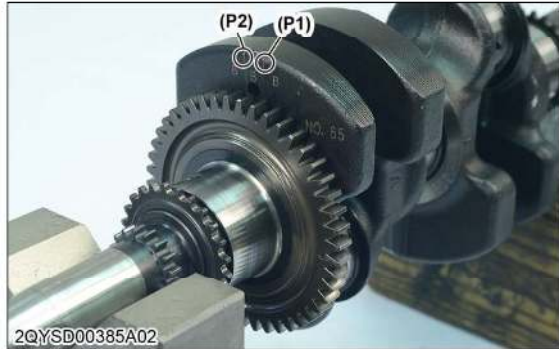

2. Make note of the one digit letter code etched into the connecting rod caps. For example, in the illustration shown below, the one digit code is **[B]**.



### 8.4.5 Replacing connecting rod bearings

#### ■ IMPORTANT

- The crankcase, crankshaft, and connecting rods each have special codes allowing them to be

## 4. Structure of front wheel drive

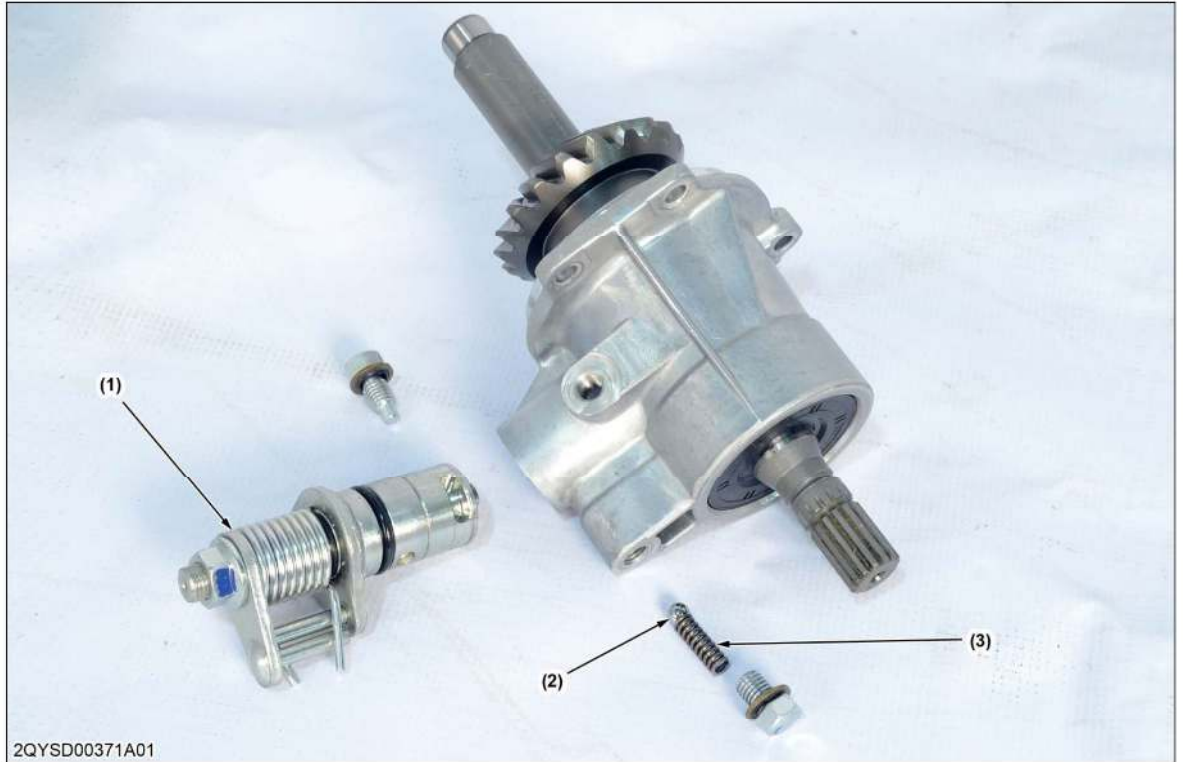

3. Make sure the adjusting nuts (3) on the lever side are adjusted to the center of the threaded area.



(2) 4WD lever (3) Adjusting nut

4. Loosen the adjusting nuts (4) at the transmission side.
5. Shift the 4WD shift arm (5) to the 2WD position.



(4) Adjusting nut (5) 4WD shift arm

6. Fix the 4WD lever (2) in the 2WD position.
7. Remove any slack in the cable.
8. Check that the cable moves smoothly.

**(When reassembling)**

- Tighten the adjusting nuts to the specified torque.

Tightening torque	Adjusting nut	54.4 to 74.8 N·m 5.55 to 7.62 kgf·m 40.2 to 55.1 lbf·ft
-------------------	---------------	---

**4.3 Checking differential lock cable (Adjusting the length of the cable for differential lock)**

**CAUTION**

- When checking, park the machine on flat ground, apply the parking brake.

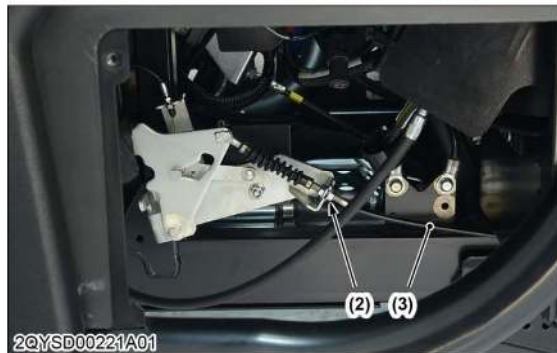

(1) Differential lock pedal (2) Adjusting nut (3) Differential lock cable (4) Adjusting nut (5) Differential lock spring (6) Differential lock lever

1. Make sure the adjusting nuts (4) on the transmission side are adjusted to the center of the threaded area.
2. Remove the L.H. center cover.
3. Adjust the nut (2) on the pedal side so there is no play.
4. Check to make sure the differential lock cable (3) moves smoothly.
5. Check to make sure when differential lock pedal (1) is operated that the differential lock lever (6) on the transmission is fully engaged.

- Remove the rear brake hose clamps, rear brake hose, and rear brake pipe.

**(When reassembling)**

- Install packing on both sides of brake hose eye bolt (2).
- Bleed the air out of the brake system after brake components are reassembled.

Tightening torque	Brake hose eye bolt	27.0 to 30.0 N·m 2.76 to 3.05 kgf·m 20.0 to 22.1 lbf·ft
	Brake pipe flare nut	13.0 to 17.0 N·m 1.33 to 1.73 kgf·m 9.59 to 12.5 lbf·ft

**5.1.15 Removing rear shock absorber**

**Tools required**

- Shell Gadus S5 T100 grease or equivalent

- Set a jack under the lower rear arm (1). Raise the jack until it touches the lower rear arm under the rear knuckle case.
- Remove the lower flange bolt (3) and lock nut (2).
- Remove the upper shock absorber pin (5).
- Remove the rear shock absorber (4).

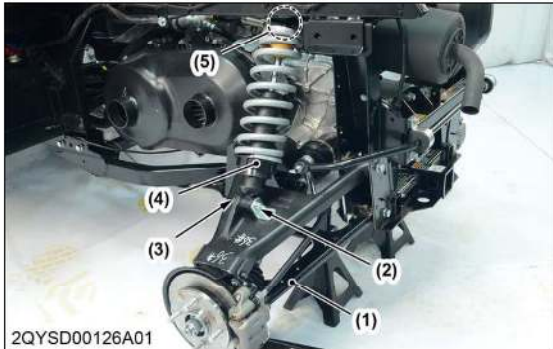

- |                    |                    |
|--------------------|--------------------|
| (1) Lower rear arm | (4) Shock absorber |
| (2) Lock nut       | (5) Pin            |
| (3) Flange bolt    |                    |

**(When reassembling)**

- Apply grease (Shell Gadus S5 T100 or equivalent) to the lower shock absorber bushing before inserting collar.
- Tighten to the specified tightening torque.

Tightening torque	Shock absorber lock nut	69.1 to 80.3 N·m 7.05 to 8.18 kgf·m 51.0 to 59.2 lbf·ft
-------------------	-------------------------	---

**5.1.16 Removing rear drive shaft**

**NOTE**

- The CV joints should not exceed the allowable angle (A) when being disassembled or reassembled.

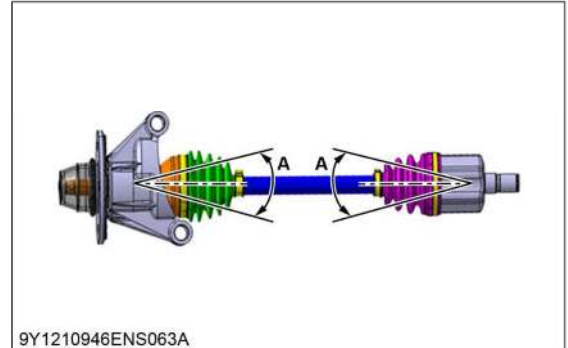

A: -0.52 to +0.52 rad (-30 to +30°)

**Tools required**

- RAILMASTER grease or equivalent

- Remove the rear stabilizer (6) and stabilizer linkage (5).
- Remove the rear arm mounting bolts and nuts.
- Remove the rear upper arm (2).
- Remove the rear drive shaft (1) with rear knuckle assembly (3) and brake caliper.

**IMPORTANT**

- Do not pull the rear drive shaft by the rear knuckle assembly. This can cause damage to the rear drive shaft.

- Remove the rear lower arm (4).

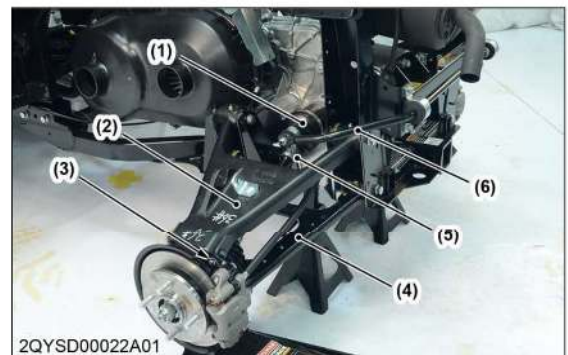

- |                      |                        |
|----------------------|------------------------|
| (1) Rear drive shaft | (5) Stabilizer linkage |
| (2) Upper arm        | (6) Rear stabilizer    |
| (3) Knuckle assembly |                        |
| (4) Lower arm        |                        |

3. Remove the driven pulley (4).

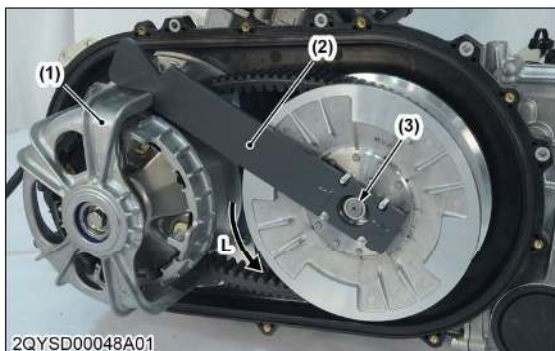

2QYSD00048A01



2QYSD00049A01

- (1) CVT bracket
- (2) Driven pulley lock lever
- (3) Nut
- (4) Driven pulley
- L: Loosen

**(When reassembling)**

- Apply grease (NLGI-3 grease or equivalent) to driven shaft.
- Install the driven pulley lock lever (2) as shown in the figure to tighten the driven pulley nut (3).

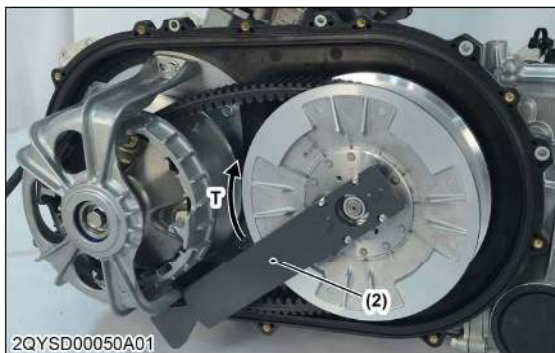

2QYSD00050A01

- (2) Driven pulley lock lever
- T: Tighten

- Tighten to the specified tightening torque.

Tightening torque	Driven pulley nut	176 to 203 N·m 18.0 to 20.7 kgf·m 130 to 149 lbf·ft
-------------------	-------------------	---

**5.2.7 Removing CVT inside cover**

1. Remove the CVT inside cover mounting bolts (1).
2. Remove the straight pins (3) and CVT inside cover (2).



2QYSD00051A01

- (1) Bolt
- (2) CVT inside cover
- (3) Straight pin

**(When reassembling)**

Tightening torque	CVT inside cover bolt	17.6 to 20.6 N·m 1.80 to 2.10 kgf·m 13.0 to 15.1 lbf·ft
-------------------	-----------------------	---

**5.2.8 Removing 4WD shaft**

**Tools required**

- RAILMASTER grease

1. Remove the 4WD shaft bolts (1).
2. Remove the 4WD shaft (2).

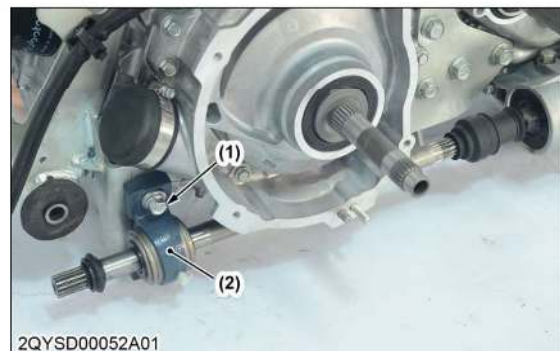

2QYSD00052A01

- (1) 4WD shaft bolt
- (2) 4WD shaft

**(When reassembling)**

- Apply grease (RAILMASTER) evenly along the splines.

Tightening torque	4WD shaft bolt	39.2 to 44.1 N·m 4.00 to 4.49 kgf·m 29.0 to 32.5 lbf·ft
-------------------	----------------	---

4. Measure the backlash by thickness of the point where solder is the thinnest.

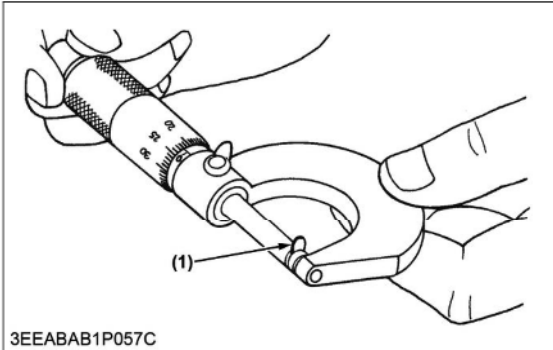

(1) Solder

5. If the backlash exceeds the service limit, adjust with the differential side gear shims.

Backlash between differential pinion and differential side gear	Service specification	0.15 to 0.30 mm 0.0059 to 0.0118 in.
---	-----------------------	---

**(Reference)**

Thickness of shims	0.8 mm 0.03 in.
	1.0 mm 0.039 in.
	1.2 mm 0.047 in.

**6.9 Checking brake disk and friction plate wear**

**Tools required**

- Outside micrometer

1. Measure the brake disk thickness and the friction plate thickness with an outside micrometer.

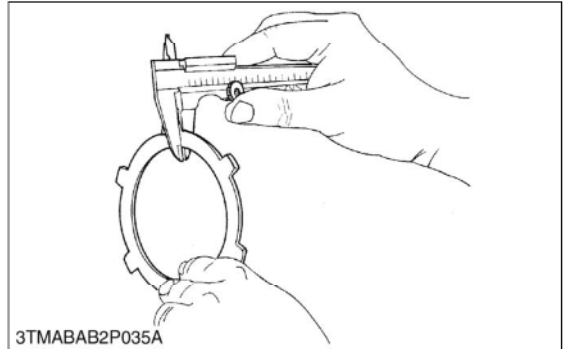
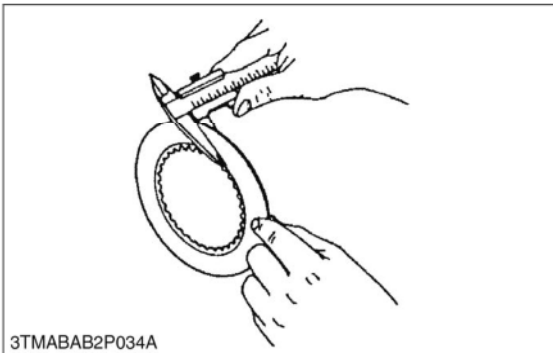

2. If the thickness is less than the service limit, replace it.

Brake disk thickness	Service specification	2.06 to 2.26 mm 0.0811 to 0.0889 in.
	Service limit	1.9 mm 0.075 in.

Friction plate thickness	Service specification	1.15 to 1.25 mm 0.0453 to 0.0492 in.
	Service limit	1.0 mm 0.039 in.

5. SUSPENSION

1. Jack up at the plate under the front axle case only.

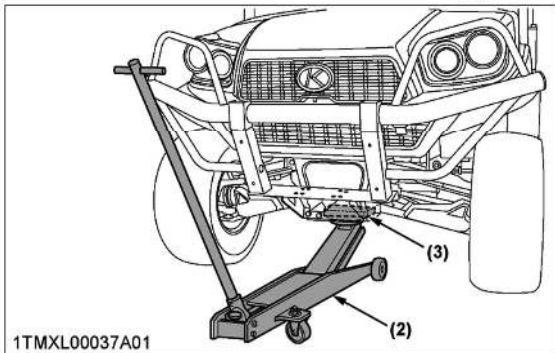
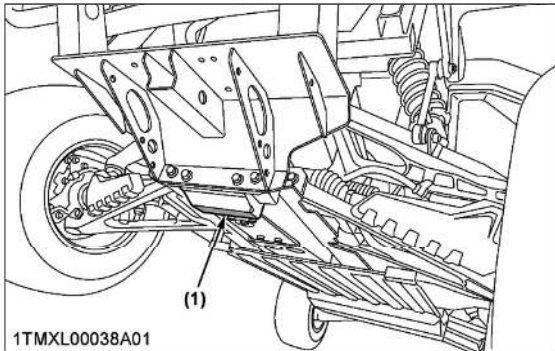

- (1) Plate under the front axle case
- (2) Floor jack
- (3) Wooden block

2. Remove the front wheel.

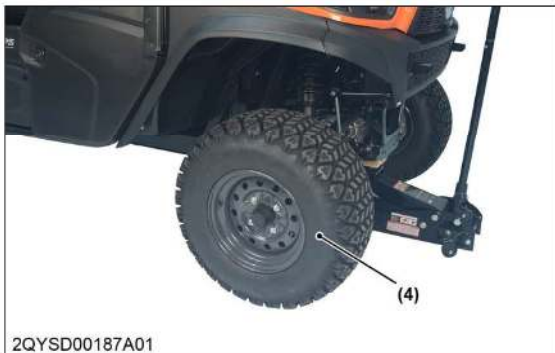

- (4) Front wheel

(When reassembling)

Tightening torque	Aluminum wheel mounting nut	130.0 to 150.0 N·m 13.26 to 15.29 kgf·m
	Steel wheel mounting nut	95.89 to 110.6 lbf·ft

4.2.2 Removing front upper cover

1. Remove the front upper cover 2 (1).
2. Remove the front upper cover 1 (2) or front upper cover 3 (3), depending on removing R.H. or L.H. front shock absorber.

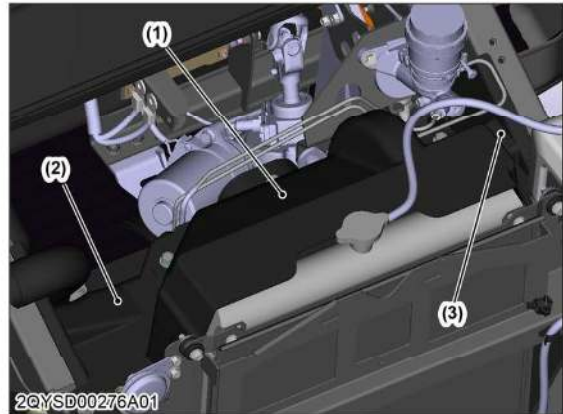

- (1) Front upper cover 2
- (2) Front upper cover 1
- (3) Front upper cover 3

4.2.3 Removing front shock absorber

Tools required

- Shell Gadus S5 T100 grease or equivalent

1. Set a jack under the lower front arm. Raise the jack until it touches the lower front arm under the front knuckle case.
2. Remove the lower flange bolt (3) and lock nut (2).
3. Remove the upper shock absorber pin (4).
4. Remove the front shock absorber (1).

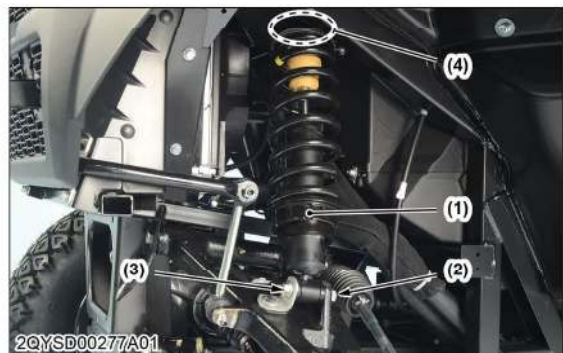

- (1) Shock absorber
- (2) Lock nut
- (3) Flange bolt
- (4) Pin

(When reassembling)

- Apply grease (Shell Gadus S5 T100 or equivalent) to the lower shock absorber bushing before inserting collar.

# SERVICING

## 1. Troubleshooting for brakes

Symptom	Probable cause and checking procedure	Solution	Reference page
Poor braking force	1. Brake pedal play excessive	Adjust the brake pedal play.	6-11
	2. Brake disk worn	Replace the brake disc.	6-26 6-33 6-33 6-34
	3. Brake pad worn	Replace the brake pad.	6-14 6-17 6-27
	4. Brake fluid insufficient or improper	Fill or change with specified brake fluid.	6-12
	5. Brake fluid leakage from brake pipes, or master cylinder	Repair or replace the brake pipes, or the master cylinder.	6-15
	6. Master cylinder malfunctioning	Repair or replace the master cylinder.	6-15 6-15
Uneven braking force	1. Brake disk worn	Replace the brake disc.	6-26 6-33 6-33 6-34
	2. Brake pad worn	Replace the brake pad.	6-14 6-17 6-27
	3. Brake fluid leakage from brake pipes, or master cylinder	Repair or replace the brake pipes, or the master cylinder.	6-15
	4. Master cylinder malfunctioning	Repair or replace the master cylinder.	6-15 6-15
Brake drags	1. Brake pedal play too small	Adjust the brake pedal play.	6-11
	2. Master cylinder return spring weaken or broken	Replace the master cylinder.	6-15 6-15
	3. Master cylinder malfunctioning	Repair or replace the master cylinder.	6-15 6-15
	4. Brake seal failure	Replace the brake seal.	6-2 6-18 6-28
	5. Brake lines clogged	Clean the brake lines.	6-12
	6. Brake pedal return spring weaken or broken	Replace the return spring of brake pedal.	6-1

(Continued)

## 5.2.2 Replacing front brake pad

### NOTE

- When the brake pads (4) is damaged or its thickness is less than 1 mm (0.04 in.), use the following procedure to replace the brake pads (4).

- Remove the caliper mounting bolts (2) and remove the caliper (1) with brake hose (3).

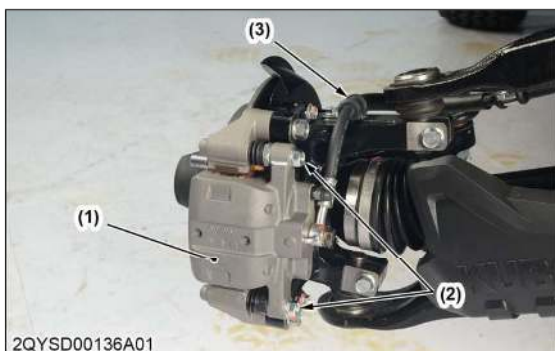

- (1) Caliper (2) Caliper mounting bolt (3) Brake hose

- Remove the brake pads (4) from the mount bracket.



- (4) Brake pad

- Clean the brake components thoroughly.
- Before installing the caliper, push the piston of the caliper by hand to make the clearance between pad and piston because the new brake pads would be thicker than used ones.
- Install the caliper to the brake disc.
- If needed, bleed the air from the brake line.

### (When reassembling)

Tightening torque	Caliper mounting bolt	19.6 to 24.5 N·m 2.00 to 2.49 kgf·m 14.5 to 18.0 lbf·ft
-------------------	-----------------------	---

## 5.3 Front brake caliper

### 5.3.1 Removing front wheel

### WARNING

To avoid serious injury, death or vehicle damage:

- Do not work under the vehicle unless it is secured by safe stands or suitable blocking.

### NOTE

- Before jacking up the vehicle, park it on a firm and level ground and chock the rear wheels.
- Select a jack that withstands the vehicle weight and set it up as shown below.

- Jack up at the plate under the front axle case only.

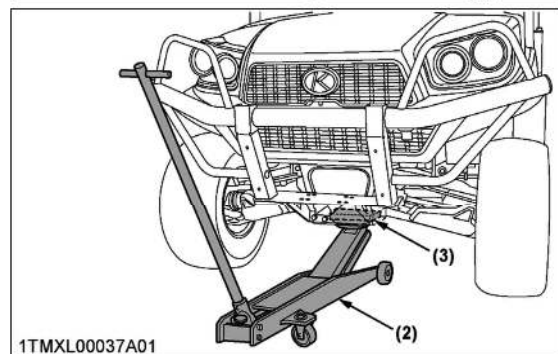
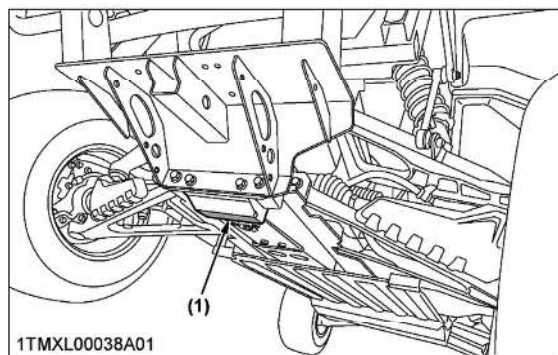

- (1) Plate under the front axle case (2) Floor jack (3) Wooden block

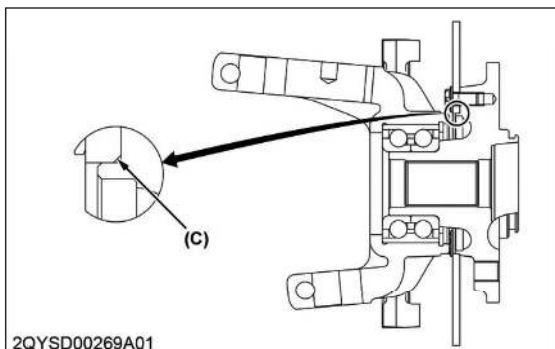

2QYSD00269A01

(C) Chamfer

Tightening torque	Brake disc coating bolt	26.5 to 30.9 N·m 2.71 to 3.15 kgf·m 19.6 to 22.7 lbf·ft
-------------------	-------------------------	---

— RELATED PAGE —  
[2.2 Jig 1 on page 2-66](#)

## 5.6 Rear brake pad

### 5.6.1 Removing rear wheel

1. Jack up the rear of the unit and secure with jack stands.
2. Remove the rear wheels (1).

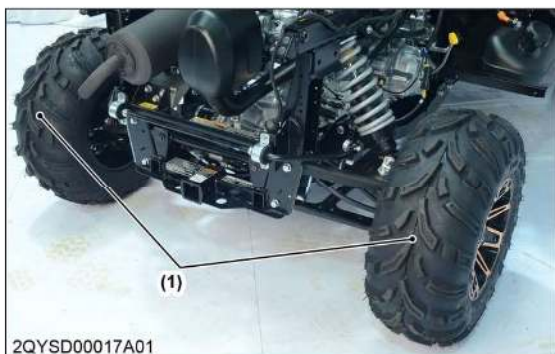

2QYSD00017A01

(1) Rear wheel

#### (When reassembling)

Tightening torque	Aluminum wheel mounting nut	130.0 to 150.0 N·m 13.26 to 15.29 kgf·m
	Steel wheel mounting nut	95.89 to 110.6 lbf·ft

### 5.6.2 Replacing rear brake pad

#### NOTE

- When the brake pads (4) is damaged or its thickness is less than 1 mm (0.04 in.), use the following procedure to replace the brake pads (4).

1. Remove the caliper mounting bolts (2) and remove the caliper (1) with brake hose (3).



2QYSD00243A01

- (1) Caliper  
(2) Caliper mounting bolt  
(3) Brake hose

2. Remove the brake pads (4) from the mount bracket.

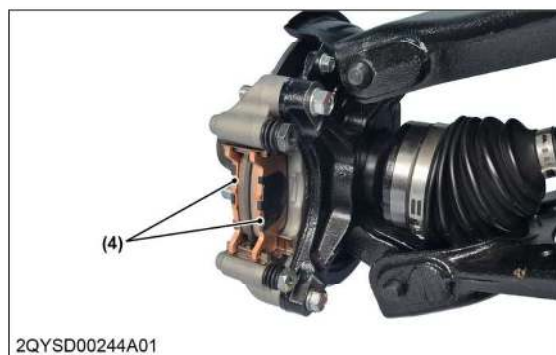

2QYSD00244A01

(4) Brake pad

3. Clean the brake components thoroughly.
4. Before installing the caliper, push the piston of the caliper by hand to make the clearance between pad and piston because the new brake pads would be thicker than used ones.
5. Install the caliper to the brake disc.
6. If needed, bleed the air from the brake line.

#### (When reassembling)

- Make sure there is no grease or oil on the mounting bolt threads before installing.
- Tighten to the specified tightening torque.

Tightening torque	Caliper mounting bolt	19.6 to 24.5 N·m 2.00 to 2.49 kgf·m 14.5 to 18.0 lbf·ft
-------------------	-----------------------	---

### 2. Structure of limited slip differential (LSD)

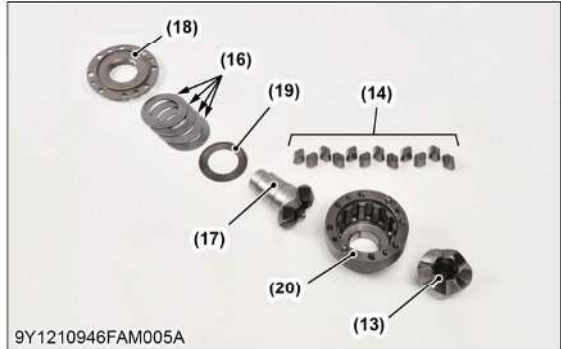
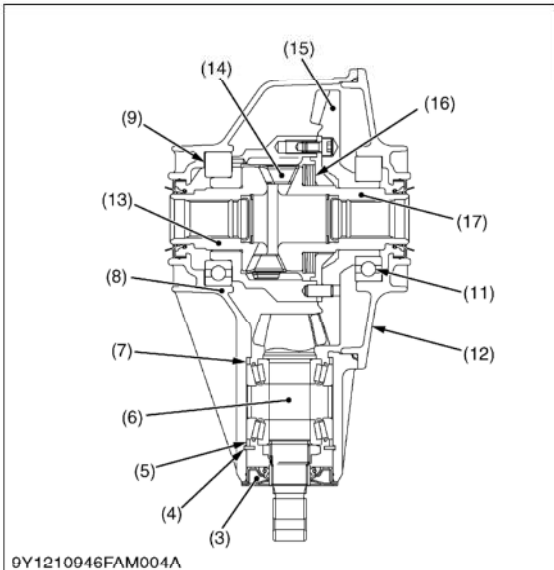
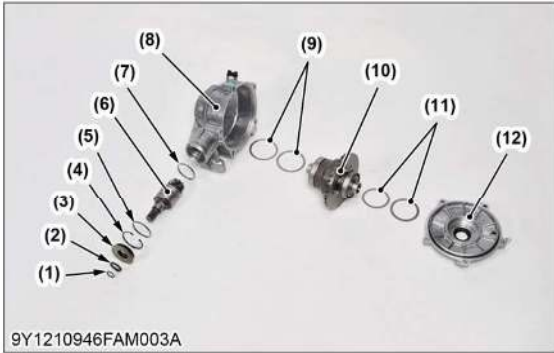

- |                                 |                            |
|---------------------------------|----------------------------|
| (1) O-ring                      | (11) Shim                  |
| (2) Plug                        | (12) Front case cover      |
| (3) Oil seal                    | (13) Cam face              |
| (4) Internal cir-clip           | (14) Cam follower          |
| (5) Collar                      | (15) Bevel gear (35T)      |
| (6) Bevel gear shaft (8T)       | (16) Disc spring           |
| (7) Collar                      | (17) Cam face              |
| (8) Front case                  | (18) Differential case cap |
| (9) Shim                        | (19) Thrust washer         |
| (10) Differential case assembly | (20) Differential case     |

The configuration of the differential gear is as shown in the figure.

The differential gear is prepared with an LSD function. This is torque sensitive, therefore, even if the temperature of the LSD rises, the torque bias ratio (TBR) is not reduced.

The structure is a differential case assembly (10), cam face (13), cam follower (14), disc spring (16), thrust washer (19), and differential case cap (18). The cam follower (14) has sintered metal and thermal processing and therefore superior durability.

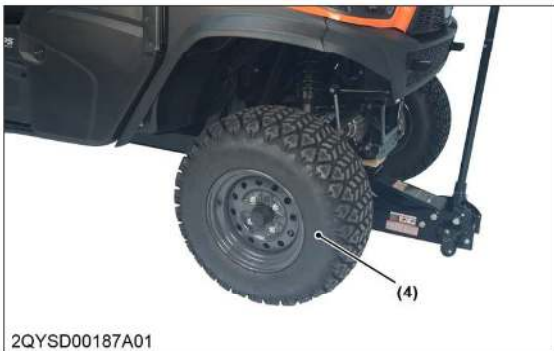
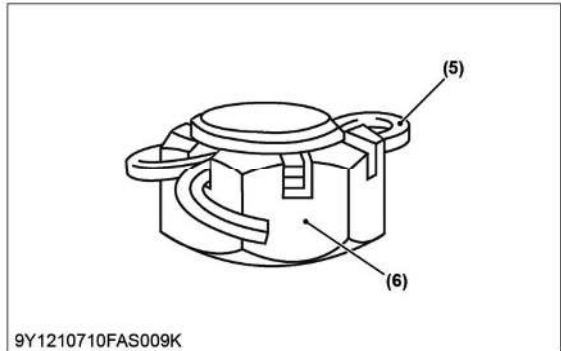
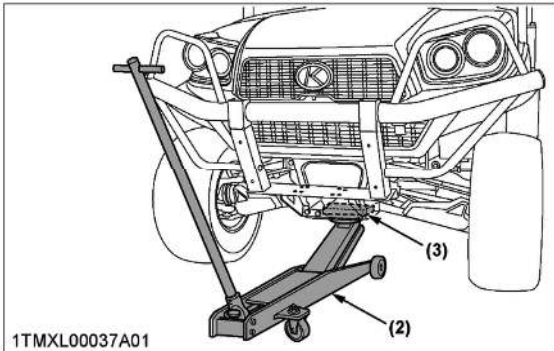
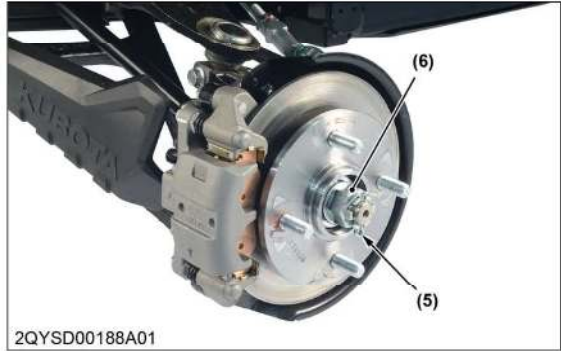
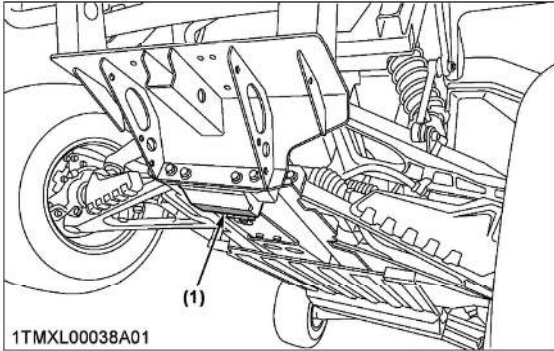

(5) Cotter pin (6) Slotted nut  
3. Remove the front wheel mounting screw.

**(When reassembling)**

**NOTE**

- Tighten the slotted nut to 190 N·m (19.4 kgf·m, 140 lbf·ft). If the slot and pin hole do not meet, tighten the nut until they do meet, and install cotter pin.
- After tightening the front axle slotted nut to specified torques, install a cotter pin as shown in the figure.

- (1) Plate under the front axle case (3) Wooden block  
(2) Floor jack (4) Front wheel

1. Jack up at the plate under the front axle case only.
2. Remove the cotter pin (5) and just loosen the slotted nut (6) for drive shaft.

Tightening torque	Front axle slotted nut	190 to 200 N·m 19.4 to 20.3 kgf·m 141 to 147 lbf·ft
	Aluminum wheel mounting nut	130.0 to 150 N·m 13.3 to 15.2 kgf·m
	Steel wheel mounting nut	95.9 to 110 lbf·ft

7. FRONT AXLE

5. When the backlash is too large, decrease the number of shims (L.H.) in the side of the bevel gear, and insert the shim (R.H.) of the same thickness as the removed ones to the opposite side.

6. When the backlash is too small, do the opposite way to increase backlash. Adjust the backlash properly by repeating the above procedure.

Backlash between bevel pinion shaft and bevel gear	Service specification	0.24 mm or less 0.0094 in. or less
--	-----------------------	---------------------------------------

■ NOTE

- Make sure that the bevel pinion shaft can be rotated smoothly after assembled.

(Reference)

Thickness of shims (1) (L.H.)	0.20 mm 0.0079 in.
	0.30 mm 0.012 in.
	0.50 mm 0.020 in.
Thickness of shims (2) (R.H.)	0.10 mm 0.0039 in.
	0.20 mm 0.0079 in.
	0.30 mm 0.012 in.
Thickness of adjusting collars (3), (4)	0.50 mm 0.020 in.
	3.40 mm 0.134 in.
	3.50 mm 0.138 in.
	3.60 mm 0.142 in.
	3.70 mm 0.146 in.
	3.80 mm 0.150 in.
	3.90 mm 0.154 in.
	4.00 mm 0.157 in.
	4.10 mm 0.161 in.
	4.20 mm 0.165 in.
	4.30 mm 0.169 in.
4.40 mm 0.173 in.	
4.50 mm 0.177 in.	
4.60 mm 0.181 in.	

3. Remove the damper (3).



(2) Connector (3) Damper

4. Remove the bonnet.

### 5.1.3 Removing doors

1. Remove the flange bolts (2) and remove the doors (1).

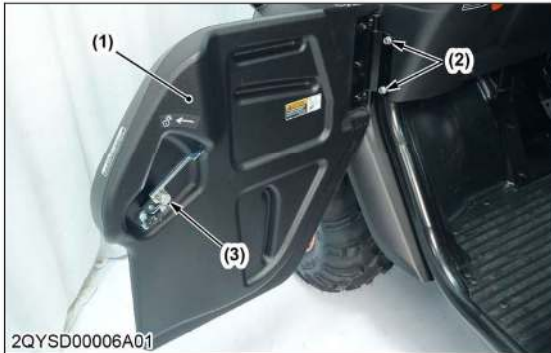

(1) Door (2) Flange bolt (3) Door lock

#### (When reassembling)

- Before tightening the flange bolts (2), close the door to make sure the door lock (3) lines up with the handrail striker.

### 5.1.4 Removing ROPS

1. Remove the rear ROPS plates (1).
2. Remove the flange bolts (4), lock nuts (5), and flange bolts (2) to disconnect the center upper cover (6) from the ROPS.
3. Remove the lock nuts (7) and disconnect the seat belt (8) from the ROPS.
4. Remove the rear ROPS bolts (3).



(1) Rear ROPS plate (6) Center upper cover  
(2) Flange bolt (7) Lock nut  
(3) Rear ROPS bolt (8) Seat belt  
(4) Flange bolt (9) ROPS  
(5) Lock nut

5. Remove the front ROPS bolts (10).

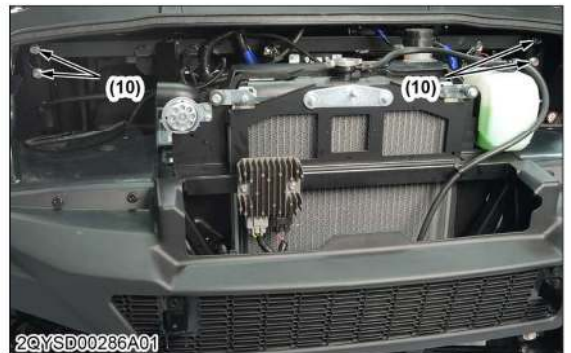

(10) Front ROPS bolt

6. Remove the ROPS (9).

#### (When reassembling)

- Tighten to the specified tightening torque.

Tightening torque	Front ROPS bolt	77.4 to 90.2 N·m 7.90 to 9.19 kgf·m 57.1 to 66.5 lbf·ft
	Rear ROPS bolt	
	Seat belt lock nut	26.0 to 30.0 N·m 2.66 to 3.05 kgf·m 19.2 to 22.1 lbf·ft

### 3.2 Function of regulator



(1) Regulator

The regulator performs rectification and voltage regulation. The regulator converts AC into DC which flows through the power consuming circuits and the battery, and also charges the battery. If, however, the battery voltage exceeds a certain level, the DC current is cut off from the charging circuit to prevent overcharging.

## 4. Lighting system

### 4.1 Function of head light switch



(1) Head light switch

	B1	T	1	2
OFF	●	●		
Lo	●		●	
Hi	●			●

2QYSD00237A01enUS

The head light switch is operative when the key switch is in the on position. Turn on the key switch and turn the head light switch clockwise, and the corresponding head lights light up on the switch. Turn the head light switch counterclockwise to the off position to turn off the head light.

### 4.2 Outline of brake lamp switch



(1) Brake lamp switch

The brake lamp switch (1) is located on the front frame. This switch is the close type. In normal operating condition, the switch is close circuit. When the brake pedal is depressed, the brake lamp switch (1) is not pushed by the brake arm, and is turned on. When the brake pedal is released, the brake lamp switch (1) is pushed by the brake arm, and is turned off.

## 5. Cooling system

### 5.1 Outline of fan motor

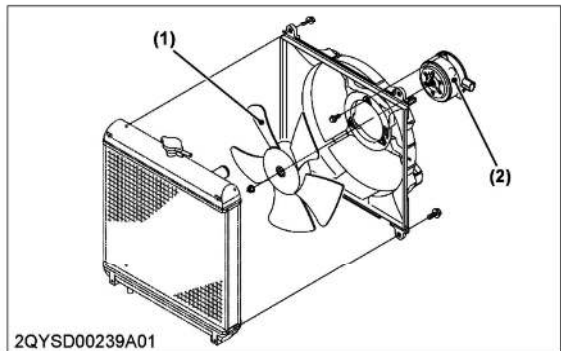

(1) Fan

(2) Fan motor

The cooling fan of this vehicle is not driven by the engine drive but an electric motor. An electric fan can be installed by separating from the engine. And, it can be operated when it is necessary.

If the battery is weak, charge the battery or replace it with a new one.

- When exchanging an old battery for a new one, use battery of equal specification in the following table.

Battery type	Volts (V)	Reserve capacity (min)	Cold cranking amps	Capacity at 20 hrs (A. H.)
SMF 26-560	12	86	560	56

(For non-accessible maintenance-free type batteries.) Maintenance-free, non-accessible batteries are designed to eliminate the need to add water. Yet the volume of electrolyte above plates may eventually become depleted due to abnormal conditions such as high heat or improper regulator setting. Use a voltmeter to check the state of charge. (See the following reference chart to determine if charging is necessary.)

Battery voltage	Reference state of charge
12.6	100 % (full charge)
12.4	75 %
12.2	50 %
12.0	25 %
11.8	0 %

### 3.1.4 Charging the battery

#### **⚠ DANGER**

To avoid serious injury or death:

- When the battery is being activated, hydrogen and oxygen gases in the battery are extremely explosive. Keep open sparks and flames away from the battery at all times, especially when charging the battery.
- Read and heed the battery safety label.

#### **⚠ WARNING**

To avoid serious injury or death:

- When disconnecting the cable from the battery, start with the negative terminal first. When connecting the cable to the battery, start with the positive terminal first.
- If the battery cable is loose, it can cause sparks or an explosion.
- Tighten the battery terminals securely and make sure the covers are installed on both the negative and positive terminals.
- Never check battery charge by placing a metal object across the posts.
- Use a voltmeter or hydrometer.

- Park the vehicle on a flat surface.
- Stop the engine.
- Remove the push rivet of the sheet and flip up the sheet.

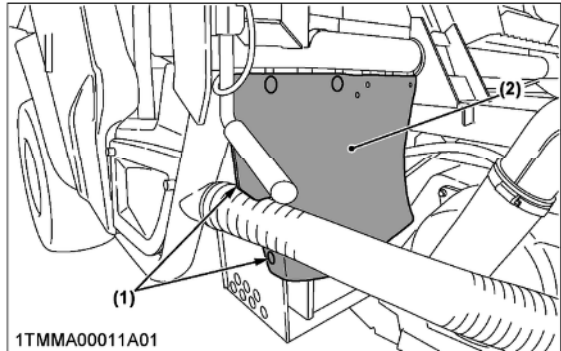

(1) Push rivet (2) Sheet

#### NOTE

- To remove the push rivet:
  - Push the pin to unlock.
  - Remove the push rivet.
- To install the push rivet:
  - Push the pin to ready to install.
  - Install the push rivet into the hole.
  - Push the pin to lock.

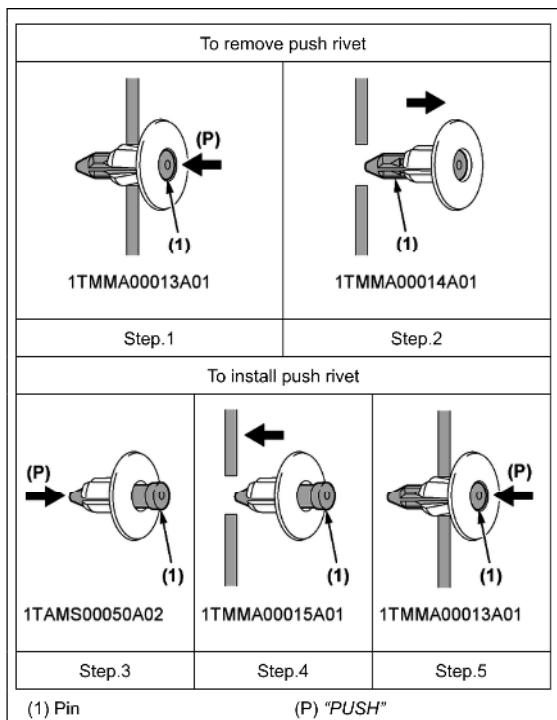

9. ELECTRICAL SYSTEM

- Disconnect the 8P connector (2) from the parking brake switch (1).

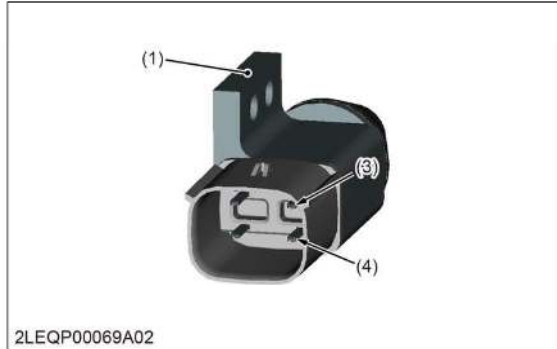

- (1) 4WD switch
- (2) 4P connector
- (3) 4 terminal
- (4) 8 terminal

- Measure the resistance with an ohmmeter across the switch terminal 4 (3) and terminal 8 (4).
- If the resistance values specified below are not indicated, the 4WD switch is damaged.

**Plunger is pushed into the switch body.**

Resistance	4 terminal (3) - 8 terminal (4)	Continuity
------------	---------------------------------	------------

**Plunger is released.**

Resistance	4 terminal (3) - 8 terminal (4)	Infinity
------------	---------------------------------	----------

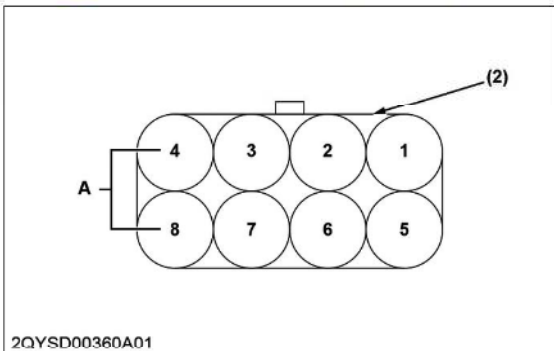

- (1) Parking brake switch
- (2) 8P connector
- A: Jumper lead

- Turn the key switch on and connect a jumper lead from the 8P connector terminal 4 and terminal 8.
- If the parking brake indicator lamp does not light, the panel circuit or wiring harness is damaged.

**3.8.11 Checking 4WD switch continuity**

- Lift the seats and remove the lower box cover and lower center cover.
- Disconnect the 4P connector (2) and remove the 4WD switch (1).

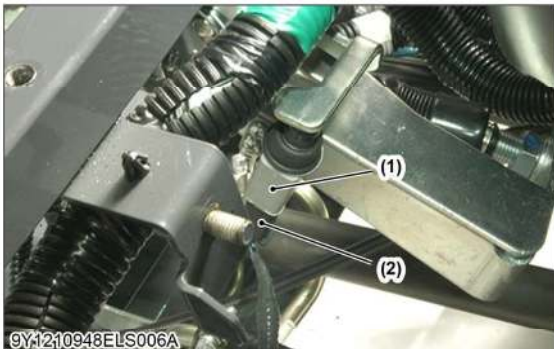

**3.8.12 Checking brake lamp switch continuity**

- Open the bonnet.

### 3.12.8 Checking TMAP sensor

1. Disconnect the 4P connector (2) from the TMAP sensor (1).



(1) TMAP sensor (2) 4P connector

2. Measure the resistance with an ohmmeter across the TMAP sensor terminal 2 and terminal 4.
3. Measure the resistance with an ohmmeter across the TMAP sensor terminal 1 and terminal 2.
4. Measure the resistance with an ohmmeter across the TMAP sensor terminal 1 and terminal 3.

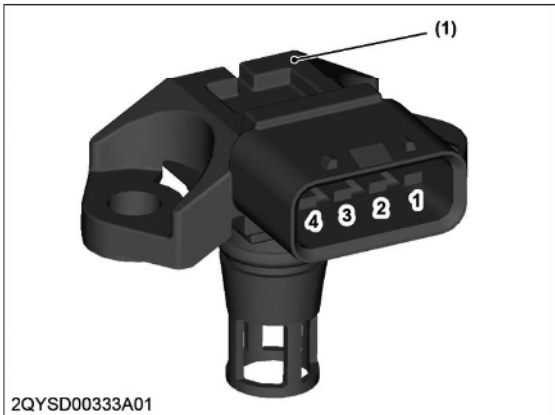

(1) TMAP sensor

5. If the measurements are not within specification, the TMAP sensor is damaged.

TMAP sensor resistance	Service specification	Terminal 2 to Terminal 4	0.117 to 28.6 kΩ
		Terminal 1 to Terminal 2	10.45 kΩ
		Terminal 1 to Terminal 3	2.39 kΩ

6. If the measurements are within specification, check the TMAP sensor for debris. If debris comes in contact with sensor, the sensor will read incorrectly.

### 3.12.9 Checking ignition coil harness connector

1. Disconnect the 3P connectors (3) from the ignition coil 1 (1) and ignition coil 2 (2).



(1) Ignition coil 1 (2) Ignition coil 2 (3) 3P connector

2. Check the condition of the connector harness. If the condition is abnormal, replace it.
3. Turn the key switch to the on position.
4. Measure the voltage between ignition coil 1 3P connector terminal 3 and ground.
5. Measure the resistance between the ignition coil 1 3P connector terminal 2 and ground.
6. Measure the resistance between the ignition coil 1 3P connector terminal 1 and the ECU connector terminal 1.
7. Measure the voltage between ignition coil 2 3P connector terminal 3 and ground.
8. Measure the resistance between the ignition coil 2 3P connector terminal 2 and ground.

### 3.13 EVAPO system (If equipped)

#### 3.13.1 Checking purge control valve harness connector (If equipped)

1. Disconnect the 2P connector (2) from purge control valve (1).



(1) Purge control valve (2) 2P connector

2. Check the condition of the connector harness and if it is abnormal, replace it.
3. Turn the key switch to the "ON" position.
4. Measure the voltage between the purge control valve 2P connector terminal 1 and ground.
5. Measure the resistance between purge control valve 2P connector terminal 1 and ECU connector terminal 13.

Wiring harness voltage	Purge control valve 2P connector terminal 1 - Ground	12 V
Wiring harness resistance	Purge control valve 2P connector terminal 1 - ECU terminal 13	Continuity

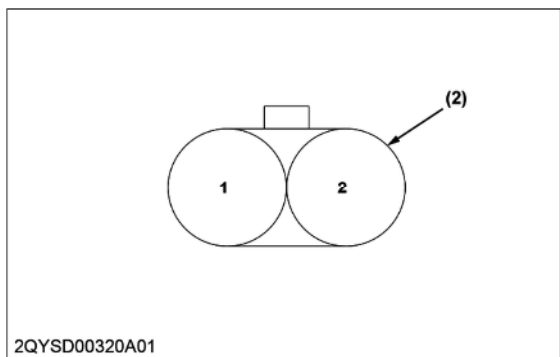

2QYSD00320A01

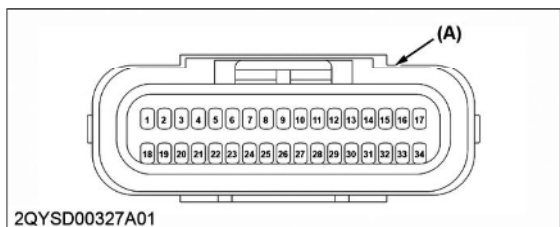

(2) 2P connector (A) ECU connector

6. If the measurements are not within specification, the ECU or wire harness is damaged.

CLICK HERE TO **DOWNLOAD** THE COMPLETE MANUAL

- Thank you very much for reading the preview of the manual.
- You can download the complete manual from: [www.heydownloads.com](http://www.heydownloads.com) by clicking the link below



- Please note: If there is no response to **CLICKING** the link, please download this PDF first and then click on it.

CLICK HERE TO **DOWNLOAD** THE COMPLETE MANUAL