



**WORKSHOP MANUAL
DIESEL ENGINE
MANUAL D'ATELIER
MOTEUR DIESEL
WERKSTATTANLEITUNG
DIESELMOTOR**

**70mm STROKE SERIES
MOTEUR DE 70mm DE COURSE
SERIENMOTOR MIT 70mm HUB**

Kubota

CLICK HERE TO **DOWNLOAD** THE COMPLETE MANUAL

- Thank you very much for reading the preview of the manual.
- You can download the complete manual from: www.heydownloads.com by clicking the link below



- Please note: If there is no response to CLICKING the link, please download this PDF first and then click on it.

CLICK HERE TO **DOWNLOAD** THE COMPLETE MANUAL

CARACTERISTIQUES

Modèle		Z500-B	Z600-B	ZH600-B	D650-B	D750-B
Nombre de cylindres		2			3	
Type		Vertical, à refroidissement par eau, 4 temps, Diesel				
Alésage x course mm		68 x 70	72 x 70		64 x 70	68 x 70
Cylindrée totale cm ³		508	570		675	762
Puissance aux freins	Puissance continue SAE, Net kW/tr/mn (HP/tr/mn)	6,3/3000 (8,5/3000)	8,2/3200 (11,3/3200)	8,6/3600 (11,5/3600)	8,6/3000 (11,5/3000)	9,7/3000 (13,0/3000)
	Puissance intermittente SAE, Net kW/tr/mn (HP/tr/mn)	7,46/3000 (10,0/3000)	9,3/3200 (12,5/3200)	10,4/3600 (14,0/3600)	9,7/3000 (13,0/3000)	11,2/3000 (15,0/3000)
	Puissance intermittente SAE, brut kW/tr/mn (HP/tr/mn)	8,2/3000 (11,0/3000)	10,4/3200 (13,8/3200)	11,5/3600 (15,5/3600)	11,2/3000 (14,3/3000)	12,7/3000 (16,5/3000)
	DIN6271-NA kW/tr/mn (CV/tr/mn)	6,25/3000 (8,5/3000)	8,1/3200 (11,0/3200)	8,5/3600 (11,5/3600)	8,5/3000 (11,5/3000)	9,6/3000 (13,0/3000)
	DIN6271-NB kW/tr/mn (CV/tr/mn)	7,0/3000 (9,5/3000)	8,8/3200 (12,0/3200)	9,9/3600 (13,5/3600)	9,2/3000 (12,5/3000)	10,7/3000 (14,5/3000)
	DIN70020 kW/tr/mn (CV/tr/mn)	7,7/3000 (10,5/3000)	9,6/3200 (13,0/3200)	10,7/3600 (14,5/3600)	10,3/3000 (14,0/3000)	11,8/3000 (16,0/3000)
Régime maximum à vide tr/mn		3200	3500	3780	3200	
Régime minimum à vide tr/mn		800				
Couple maximum N-m/tr/mn kgf-m/tr/mn		28,0/1800 2,86/1800	32,9/2000 3,36/2000	33,2/2000 3,39/2000	36,5/1800 3,72/1800	42,2/1800 4,30/1800
Chambre de combustion		Sphérique				
Pompe d'injection		Bosch K Type Mini				
Régulateur		Mécanique centrifuge à bille				
Sens de rotation		En sens inverse des aiguilles d'une montre (en regardant côté volant)				
Injecteurs		Type Bosch à jet				
Calage de l'injection		25° (0,44 rad.) avant PMH				
Order d'injection		1-2			1-2-3	
Pression d'injection		13,73 MPa (140 kgf/cm ²)				
Taux de compression		22:1				
Lubrification		Forcée, par pompe				
Indication de pression d'huile		Par contact électrique				
Filtre de lubrification		Filtre à élément papier (à type cartouche)				
Refroidissement		Radiateur sous pression, circulation forcée avec pompe à eau (non compris dans le moteur de base)				
Démarrage V, kW		Démarrage électrique avec démarreur (12,0,8)				
Dispositif auxiliaire au démarrage		Par bougie de préchauffage, dans la chambre de combustion				
Alternateur		12 V, 45 AH, ou équivalent			12 V, 65 AH, ou équivalent	
Circuit de charge		12 V, 150 W				
Carburant		Gas-oil N° 2-D (ASTM D975)				
Huile de lubrification		MIL-L-46152, MIL-L-2104C, qualité supérieure à la classe CC (API)				
Capacité en huile de lubrification ℓ		2,55			4,6	
Poids (à sec) kg		69,7	70,5		82,6	82,1
Application		Source de puissance tous usages				

**M. MECHANISM
MECANISME
MECHANISMUS**

2 LUBRICATING SYSTEM

2 SYSTEME DE LUBRIFICATION

2 SCHMIERUNGSSYSTEM

[1] GENERAL

[1] GENERALITES

[1] ALLGEMEINES

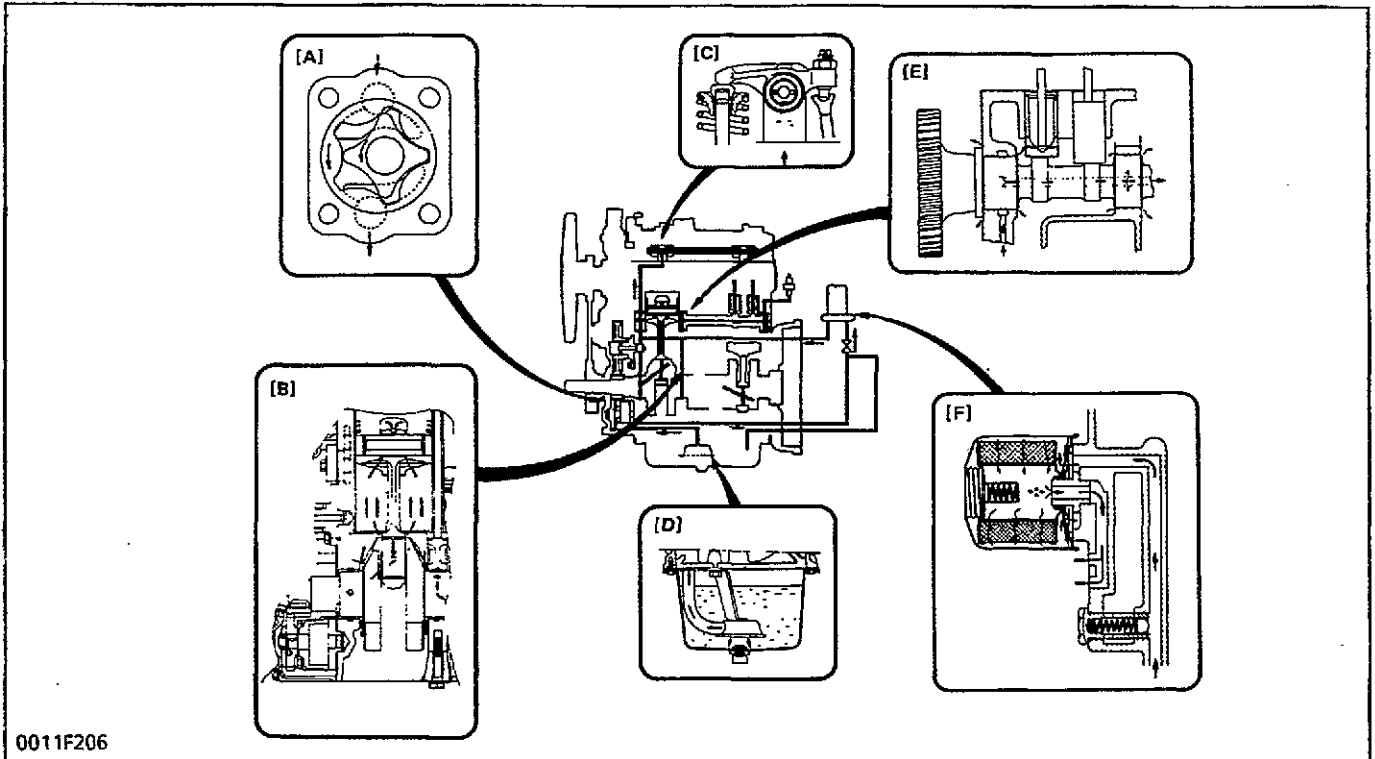

0011F206

This engine lubricating consists of oil strainer, oil pump, relief valve, oil filter cartridge and oil switch. The oil pump sucks lubricating oil from the oil pan through the oil strainer and the oil flows down to the filter cartridge, where it is further filtered. Then the oil is forced to crankshaft, connecting rods, idle gear, camshaft and rocker arm shaft to lubricate each part. Some part of oil, splashed by the crankshaft or leaking and dropping from gaps of each part, lubricates these parts: pistons, cylinders, small ends of connecting rods, tappets, pushrods, inlet and exhaust valves and timing gears.

Le système de lubrification du moteur se compose d'une crépine, d'une pompe à huile, d'une soupape de décharge, d'un filtre à huile à cartouche et d'un manocontact de pression d'huile. La pompe à huile aspire l'huile du carter par l'intermédiaire de la crépine et la force au travers de la cartouche filtre, qui en assure une filtration plus parfaite. Ensuite, l'huile est forcée vers le vilebrequin, les bielles, le pignon de renvoi, l'arbre à cames et l'axe de culbuteurs, afin de lubrifier toutes ces pièces.

L'huile éclaboussée par le vilebrequin ou dégouttant des orifices des différentes pièces lubrifie les pièces suivantes: pistons, cylindres, pied de bielle et bielle, poussoirs, tiges de poussoirs, soupapes d'admission et d'échappement et pignons de distribution.

Dieses Motorschmierungs-system umfaßt den Ölfilter, die Ölpumpe, das Überdruckventil, die Ölfilterpatrone und den Ölschalter. Die Ölpumpe saugt das Schmierungsöl aus der Ölwanne durch den Ölfilter an. Das Öl fließt sodann in die Filterpatrone, wo es weiter gefiltert wird. Anschließend wird das Öl zur Kurbelwelle sowie zu den Pleuelstangen, dem Leerlaufgetriebe, der Nockenwelle und der Kipphebelachse gepreßt und sorgt für die Schmierung eines jeden dieser Teile. Ein Teil des Öls, der von der Kurbelwelle abgeschleudert wird oder an den Zwischenräumen der Teile austritt und heruntertropft, übernimmt die Schmierung dieser Teile: Kolben, Zylinder, Pleuelstangenkopf, Stößel, Stößelstangen, Ein- und Auslaßventile und Steuerungen.

- [A] Oil Pump
- [B] Piston
- [C] Rocker Arm and Rocker Arm Shaft
- [D] Oil Strainer
- [E] Camshaft
- [F] Oil Filter Cartridge and Relief Valve

- [A] Pompe à huile
- [B] Piston
- [C] Culbuteur et axe de culbuteur
- [D] Crépine
- [E] Arbre à cames
- [F] Cartouche de filtre à huile et soupape de décharge

- [A] Ölpumpe
- [B] Kolben
- [C] Kipphebel und Kipphebelachse
- [D] Ölfilter
- [E] Nockenwelle
- [F] Ölfilterpatrone und Überdruckventil

1 INTAKE/EXHAUST SYSTEM

[1] AIR CLEANER (not included in the basic engine)

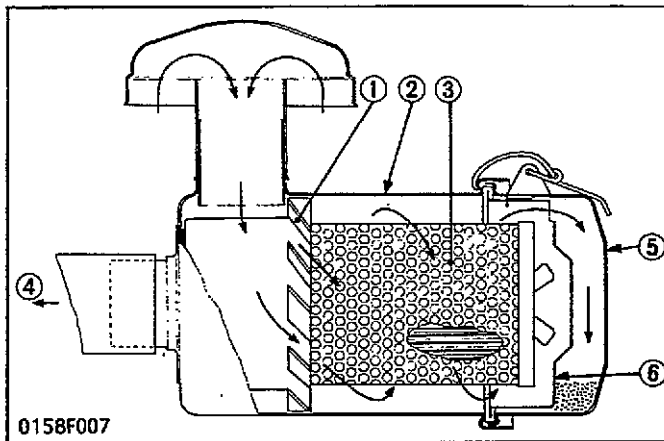

The air cleaner is a dry-cyclone type for easy maintenance. Sucked air is caused to flow in a whirling way with fin (1). As a result, heavier dust particles circulate around the circumference and enter the holes in the baffle cover (6) and accumulate in the dust cup (5). Minute dust, while circulating in the air flow, is absorbed by the element (3) and thus prevented from entering the engine.

- (1) Fin
- (2) Air Cleaner Body
- (3) Air Filter Element
- (4) To Cylinder
- (5) Dust Cup
- (6) Baffle Cover

[2] MUFFLER (not included in the basic engine)

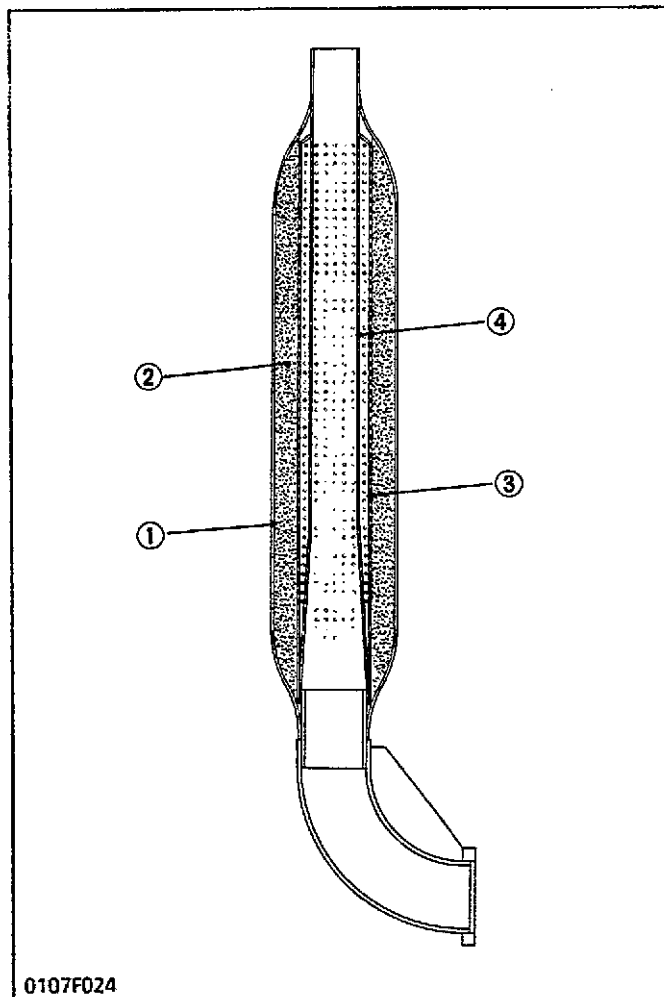

High temperature and high pressure exhaust gas is intermittently discharged by fuel combustion generating pressure waves inside the exhaust pipe which will result in noise.

The muffler is used to reduce this noise.

This muffler consists of a perforated inner tube (4) and outer tube (3), glass wool (2), main body (1), etc. The glass wool placed between the outer tube and main body, absorbs the exhaust noise of higher frequency.

- (1) Main Body
- (2) Glass Wool
- (3) Outer Tube
- (4) Inner Tube

[6] GOVERNOR

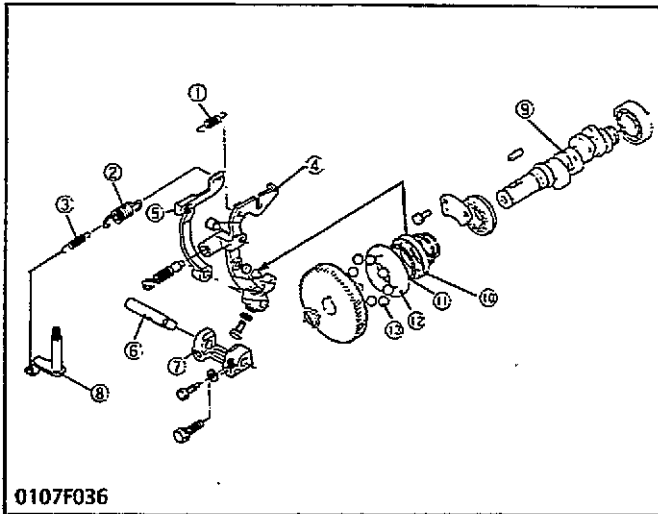

The governor serves to keep engine speed constant by automatically adjusting the amount of fuel supplied to the engine according to changes in the load. This engine employs an all-speed governor which controls the centrifugal force of the steel ball (13) weight, produced by rotation of the fuel camshaft (9), and the tension of the governor spring 1 (2) and 2 (3) are balanced.

- | | |
|-----------------------|-------------------------|
| (1) Start Spring | (8) Governor Lever |
| (2) Governor Spring 1 | (9) Fuel Camshaft |
| (3) Governor Spring 2 | (10) Governor Ball Case |
| (4) Fork Lever 1 | (11) Steel Ball |
| (5) Fork Lever 2 | (12) Governor Sleeve |
| (6) Fork Lever Shaft | (13) Steel Ball |
| (7) Fork Lever Holder | |

■ At start

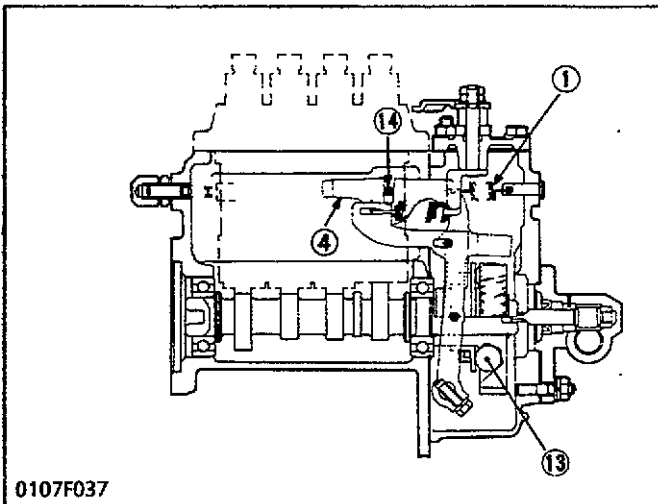

Since the steel balls (13) have no centrifugal force, a fork lever 1 (4) is pulled to the right by the starter spring (1). Accordingly, the control rack (14) moves to the maximum injection position to assure easy starting.

- (14) Control Rack

■ At idling

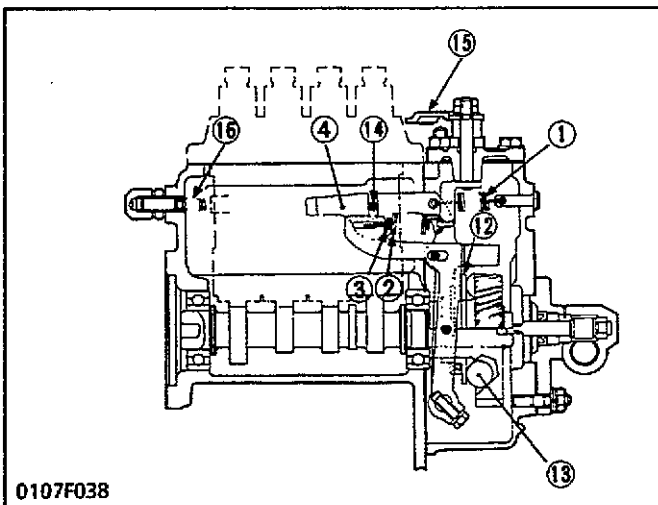

When the speed control lever (15) is set at the idling position after the engine starts, the governor spring 1 (2) does not work at all and the governor spring 2 (3) does only act slightly. The governor sleeve (12) is pushed leftward by a centrifugal force of steel balls (13).

Therefore, the fork lever 1 (4) and control rack (14) are moved to the left by the governor sleeve and then the idling limit spring (16) is compressed by the control rack. As a result, the control rack is kept at a position where a centrifugal force of steel balls and forces start spring (1), governor spring 2 and idling limit spring are balanced, providing stable idling.

- (15) Speed Control Lever
(16) Idling Limit Spring

S.

**DISASSEMBLING AND SERVICING
DEMONTAGE ET ENTRETIEN
AUSBAU UND WARTUNG**

Symptom	Probable Cause	Solution	Reference Page
Excessive lubricant oil consumption	<ul style="list-style-type: none"> ● Piston ring's gap facing the same direction ● Oil ring worn or stuck ● Piston ring groove worn ● Valve stem and guide worn ● Crankshaft bearing, and crank pin bearing worn 	Shift ring gap direction Replace Replace the piston Replace Replace	S-75 S-93 S-101
Fuel mixed into lubricant oil	<ul style="list-style-type: none"> ● Injection pump's plunger worn ● Injection pump broken 	Replace pump element or pump Replace	S-113
Water mixed into lubricant oil	<ul style="list-style-type: none"> ● Head gasket defective ● Cylinder block or cylinder head flawed 	Replace Replace	
Low oil pressure	<ul style="list-style-type: none"> ● Engine oil insufficient ● Oil strainer clogged ● Relief valve stuck with dirt ● Relief valve spring weaken or broken ● Excessive oil clearance of crankshaft bearing ● Excessive oil clearance of crank pin bearing ● Excessive oil clearance of rocker arm bearing ● Oil passage clogged ● Different type of oil ● Oil pump defective 	Replenish Clean Clean Replace Replace Replace Clean Use the specified type of oil Repair or replace	S-71 S-39
High oil pressure	<ul style="list-style-type: none"> ● Different type of oil ● Relief valve defective 	Use the specified type of oil Replace	S-39
Engine overheated	<ul style="list-style-type: none"> ● Engine oil insufficient ● Fan belt broken or elongated ● Cooling water insufficient ● Radiator net and radiator fin clogged with dust ● Inside of radiator corroded ● Cooling water flow route corroded ● Radiator cap defective ● Overload running ● Head gasket defective ● Incorrect injection timing ● Unsuitable fuel used 	Replenish Change or adjust Replenish Clean Clean or replace Clean or replace Replace Loosen the load Replace Adjust Use the specified fuel	S-39
Battery quickly discharge	<ul style="list-style-type: none"> ● Battery electrolyte insufficient ● Fan belt slips ● Wiring disconnected ● Rectifier defective ● Alternator defective ● Battery defective 	Replenish distilled water and charge Adjust belt tension or change Connect Replace Replace Change	

Piston-Piston Ring (Continued)

Item		Factory Specification	Allowable Limit
Ring gap	Compression ring 1	0.25 to 0.40 mm 0.0098 to 0.0157 in.	1.25 mm 0.0492 in.
		D950-B, V1200-B only 0.20 to 0.35 mm 0.0079 to 0.0138 in.	
	Compression ring 2	0.25 to 0.40 mm 0.0098 to 0.0157 in.	1.25 mm 0.0492 in.
		D950-B only 0.30 to 0.45 mm 0.0118 to 0.0177 in.	
	Oil ring	0.25 to 0.40 mm 0.0098 to 0.0157 in.	1.25 mm 0.0492 in.
		D650-B, D750-B only 0.20 to 0.40 mm 0.0079 to 0.0157 in.	

Connecting Rod

Connecting rod alignment	—	0.05 mm 0.0020 in.
Clearance between piston pin and small end bushing	0.014 to 0.038 mm 0.0006 to 0.0015 in.	0.15 mm 0.0059 in.
Piston pin O.D.	20.002 to 20.011 mm 0.7875 to 0.7878 in.	—
Small end bushing I.D.	20.025 to 20.040 mm 0.7884 to 0.7890 in.	—

Crankshaft

Crankshaft alignment	—	0.02 mm 0.0008 in.
Oil clearance between crankshaft and crankshaft bearing 1	0.034 to 0.106 mm 0.0013 to 0.0042 in.	0.2 mm 0.0079 in.
Crankshaft O.D.	43.934 to 43.950 mm 1.7297 to 1.7303 in.	—
Crankshaft bearing 1 I.D.	43.984 to 44.040 mm 1.7317 to 1.7339 in.	—
Oil clearance between crankshaft and crankshaft bearing 2	0.034 to 0.092 mm 0.0013 to 0.0036 in.	0.2 mm 0.0079 in.
Crankshaft O.D.	43.934 to 43.950 mm 1.7297 to 1.7303 in.	—
Crankshaft bearing 2 I.D.	43.984 to 44.026 mm 1.7317 to 1.7333 in.	—
Oil clearance between crank pin and crank pin bearing	0.029 to 0.087 mm 0.0011 to 0.0034 in.	0.2 mm 0.0079 in.
Crank pin O.D.	36.959 to 36.975 mm 1.4551 to 1.4557 in.	—
Crank pin bearing I.D.	37.004 to 37.046 mm 1.4569 to 1.4585 in.	—
Crankshaft side clearance	0.15 to 0.31 mm 0.0059 to 0.0122 in.	0.5 mm 0.0197 in.
Crankshaft sleeve wear	—	0.1 mm 0.0039 in.

CLICK HERE TO **DOWNLOAD** THE COMPLETE MANUAL

- Thank you very much for reading the preview of the manual.
- You can download the complete manual from: www.heydownloads.com by clicking the link below



- Please note: If there is no response to CLICKING the link, please download this PDF first and then click on it.

CLICK HERE TO **DOWNLOAD** THE COMPLETE MANUAL

Kolben-Kolbenring

Teil		Werkdaten	Zulässiger Grenzwert
Innendurchmesser des Kolbenbolzenbohrloch		20,000 bis 20,013 mm	20,03 mm
Spiel zwischen Verdichterring 2 und Ringnut		0,085 bis 0,112 mm	0,20 mm
Kolbenringnutbreite		1,555 bis 1,570 mm	–
Verdichterringbreite 2		1,458 bis 1,470 mm	–
Jeu entre le segment racleur et la rainure de segment		0,020 bis 0,055 mm	0,20 mm
Largeur de la rainure de segment		4,010 bis 4,030 mm	–
Largeur du segment racleur		3,975 bis 3,990 mm	–
Kolbenringspalt	Verdichterring 1		1,25 mm
		D950-B, V1200-B	
	Verdichterring 2		1,25 mm
		D950-B	
	Ölabstreifring		1,25 mm
		D650-B, D750-B	

Pleuelstange

Pleuelstangenausrichtung	–	0,05 mm
Spiel zwischen Kolbenbolzen und Pleuelbuchse	0,014 bis 0,038 mm	0,15 mm
Kolbenbolzen Außendurchmesser	20,002 bis 20,011 mm	–
Pleuelbuchse Innendurchmesser	20,025 bis 20,040 mm	–

Kurbelwelle

Kurbelwellenausrichtung	–	0,02 mm
Ölspiel zwischen Kurbelwelle und Kurbelwellenlager 1	0,034 bis 0,106 mm	0,2 mm
Kurbelwelle Außendurchmesser	43,934 bis 43,950 mm	–
Kurbelwellenlager 1 Innendurchmesser	43,984 bis 44,040 mm	–
Ölspiel zwischen Kurbelwelle und Kurbelwellenlager 2	0,034 bis 0,092 mm	0,2 mm
Kurbelwelle Außendurchmesser	43,934 bis 43,950 mm	–
Kurbelwellenlager 2 Innendurchmesser	43,984 bis 44,026 mm	–
Ölspiel zwischen Kurbelzapfen und Pleuellagerschale	0,029 bis 0,087 mm	0,2 mm
Kurbelzapfen Außendurchmesser	36,959 bis 36,975 mm	–
Pleuellagerschale Innendurchmesser	37,004 bis 37,046 mm	–
Seitenspiel der Kurbelwelle	0,15 bis 0,31 mm	0,5 mm
Abnutzung der Kurbelwellenbuchse	–	0,1 mm

(3) Check Point of Every 100 hours

Changing Engine Oil

1. After warming up, stop the engine.
2. To change the used oil, remove the drain plug at the bottom of the engine and drain off the oil completely.
3. Reinstall the drain plug.
4. Fill the new oil up to the upper notch on the dipstick.

■ IMPORTANT

- Engine oil should be MIL-L-46152/MIL-L-2104C or have properties of API classification CC/CD grades.
- Change the type of engine oil according to the ambient temperature.

Above 25°C (77°F)----- SAE 30 or 10W-30

0°C to 25°C (32°F to 77°F)----- SAE 20 or 10W-30

Below 0°C (32°F)----- SAE 10 W or 10W-30

Changing Engine Oil Filter Cartridge

1. Remove the oil filter cartridge with a filter wrench.
2. Apply engine oil to the rubber gasket on the new cartridge.
3. Screw the new cartridge in by hand.

■ NOTE

- Over-tightening may cause deformation of rubber gasket.
- After cartridge has been replaced, engine oil normally decreases a little.
Check the oil level and add new oil to the specified level.

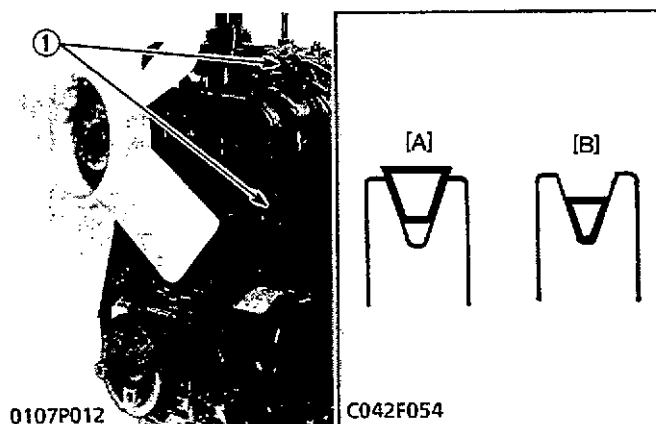

0107P012

C042F054

Checking Fan Belt Tension and Checking Fan Belt

Damage

1. Check the fan belt for damage.
2. Check if the fan belt is worn and sunk in the pulley groove.
3. Replace the fan belt if the belt is damaged or nearly worn out and deeply sunk in the pulley groove.
4. Press the fan belt between fan pulley and pulley with your finger at force of 98N (10 kgf, 22 lbs).
Check if the fan belt deflection is 7 to 9 mm (0.28 to 0.35 in.)
5. If the deflection is not within the factory specifications, adjust with the tension pulley adjusting bolts (1).

(1) Tension Pulley Adjusting Bolts

[A] Good

[B] Bad

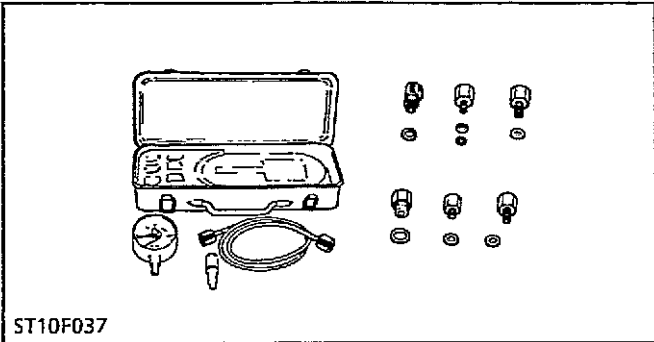

Oil Pressure Tester

Code No: 07916-32031

Application: Use for measuring lubricating oil pressure.

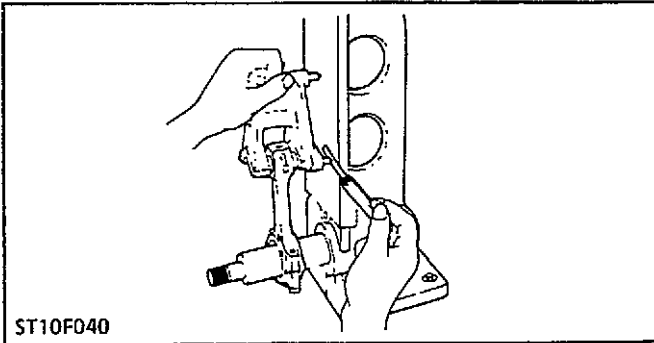

Connecting Rod Alignment Tool

Code No: 07909-31661

Application: Use for checking the connecting rod alignment.

Applicable: Connecting rod big end I.D. 30 to 75 mm (1.18 to 2.95 in. dia.) Connecting rod length 65 to 330 mm (2.56 to 12.99 in.)

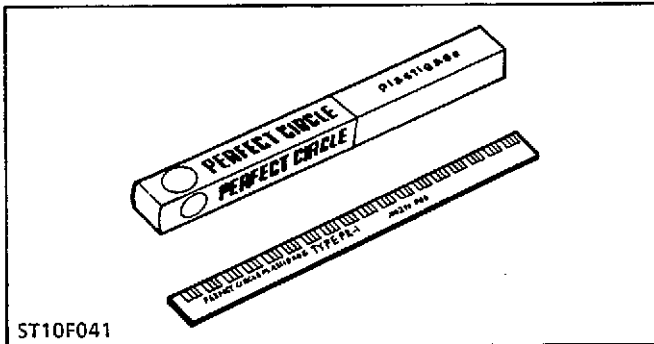

Press Gauge

Code No: 07909-30241

Application: Use for checking the oil clearance between crankshaft and bearing, etc.

Measuring range:

- Green — 0.025 to 0.076 mm (0.001 to 0.003 in.)
- Red — 0.051 to 0.152 mm (0.002 to 0.006 in.)
- Blue — 0.102 to 0.229 mm (0.004 to 0.009 in.)

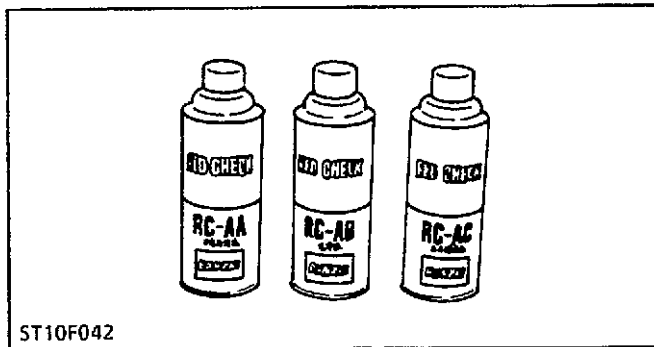

Red Check (Crack check liquid)

Code No: 07909-31371

Application: Use for checking cracks on cylinder head, cylinder block, etc.

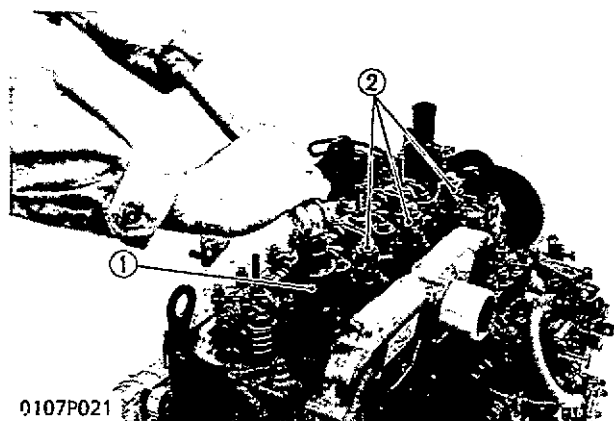

0107P021

Nozzle Holder Assembly

1. Remove the fuel overflow pipes.
2. Loosen the lock nuts, and remove the nozzle holder assemblies with a nozzle holder socket wrench 27 (1).
3. Remove the copper gaskets on the seats.

- (1) Nozzle Holder Socket Wrench
(2) Nozzle Holder Assembly

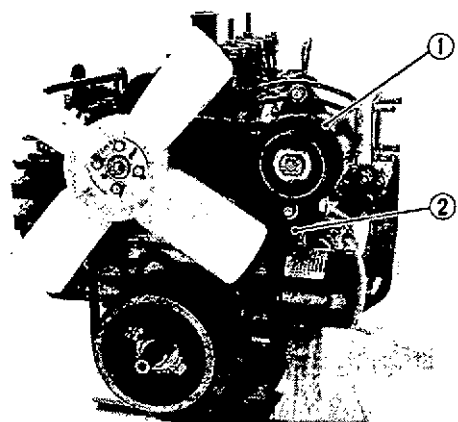

0076P013

Alternator and Fan Belt

1. Remove the alternator (1).
2. Remove the fan belt (2).

(When reassembling)

- Check to see that there are no cracks on the belt surface.

■ IMPORTANT •

- After reassembling the fan belt, be sure to adjust the fan belt tension.

- (1) Alternator
(2) Fan Belt

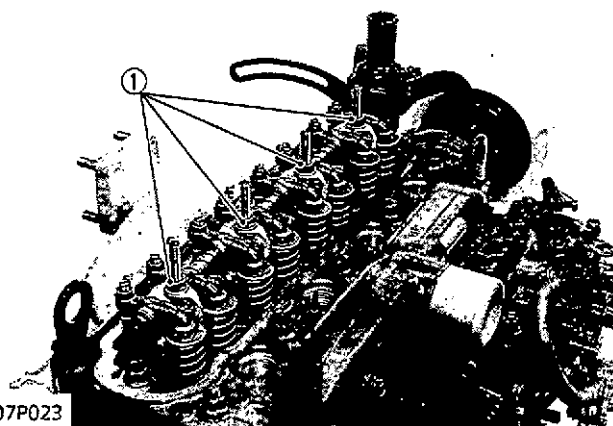

0107P023

Rocker Arm

1. Remove the rocker arm bracket mounting nuts (1).
2. Remove the rocker arm as a unit.

■ IMPORTANT

- After reassembling the rocker arm, be sure to adjust the valve clearance.

- (1) Rocker Arm Bracket Mounting Nuts

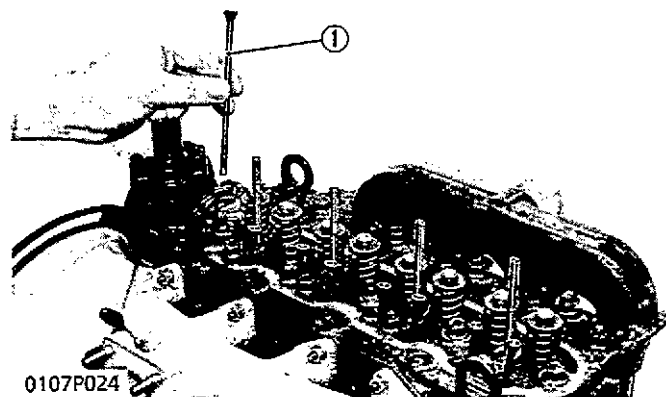

0107P024

Push Rod

1. Remove the push rods.

(When reassembling)

- When putting the push rods onto the tappets, check to see if their ends are properly engaged with the grooves.

- (1) Push Rod

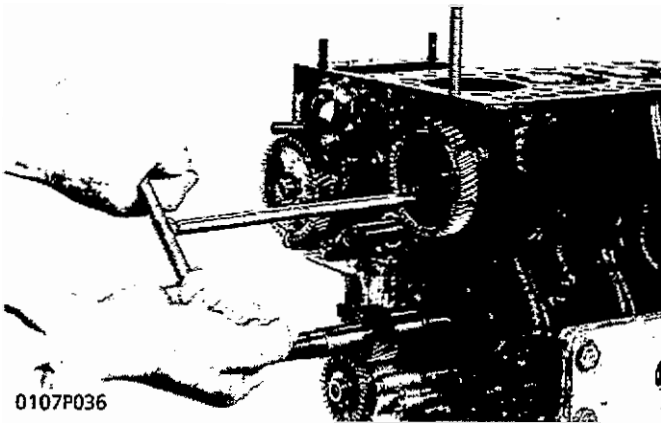

Camshaft Stopper Mounting Screw

1. Align the round hole on the cam gear with the camshaft stopper mounting screw position.
2. Remove the camshaft stopper mounting screws.

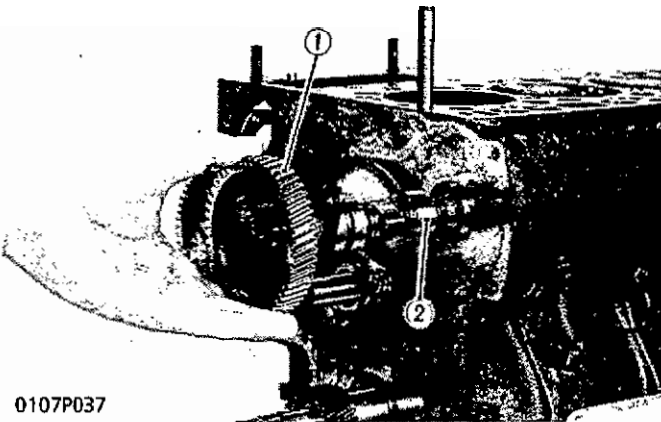

Cam Gear and Camshaft

1. Remove the cam gear (1) and camshaft (2).

(When reassembling)

- Apply engine oil thinly to the camshaft before installation.

- (1) Cam Gear
(2) Camshaft

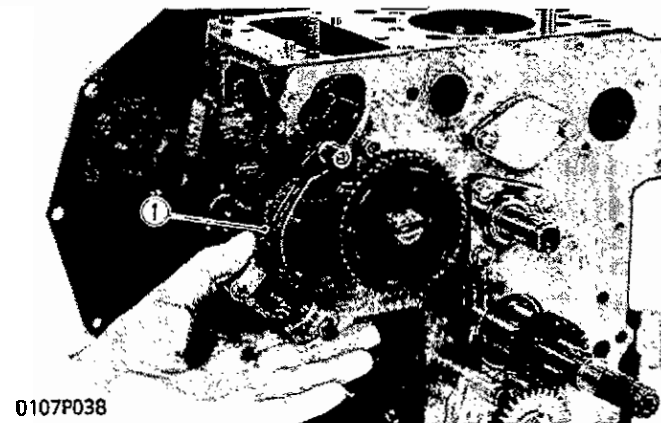

Fork Lever Assembly

1. Remove the fork lever holder mounting screws.
2. Remove the fork lever assembly (1).

- (1) Fork Lever Assembly

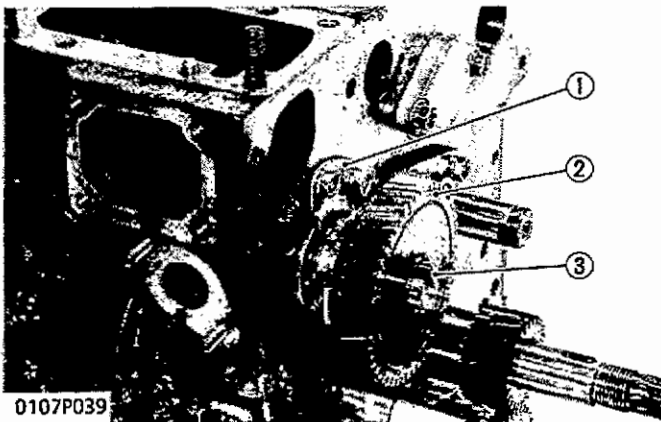

Fuel Camshaft

1. Remove the fuel camshaft stopper (1).
2. Remove the fuel camshaft (3) and injection pump gear (2).

(When reassembling)

- Apply engine oil thinly to the fuel camshaft before installation.

- (1) Fuel Camshaft Stopper
(2) Injection Pump Gear
(3) Fuel Camshaft

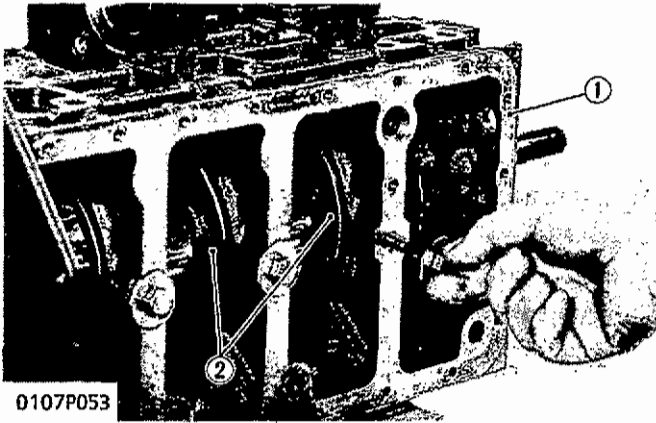
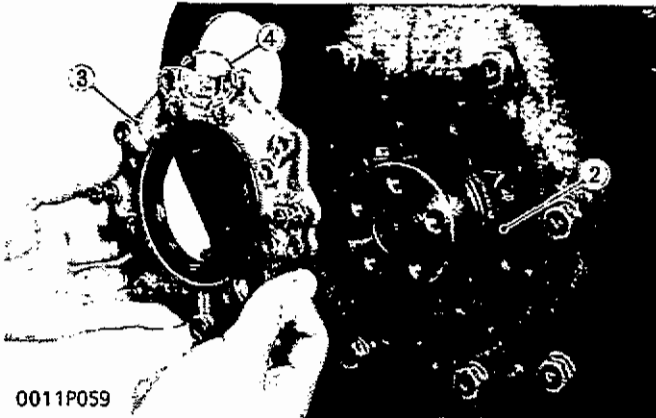

Bearing Case Cover and Crankshaft

NOTE

- Before disassembling, check the side clearance of crankshaft. Also check it during reassembly.

1. Remove the bearing case cover mounting screws.
2. Screw two removed screws into the screw hole of bearing case cover to remove it.
3. Stretch the washer and remove the bearing case screw 2.
4. Pull out the crankshaft.

(When reassembling)

IMPORTANT

- Install the crankshaft sub assembly, aligning the screw hole of main bearing case 2 (2) with the screw hole of cylinder block (1).
- Apply engine oil to the seat and thread of bearing case screw 2. After tightening it, bend the washer firmly.
- Install the bearing case cover (3) to position the casting mark "上" on it upward.
- Tighten the bearing case cover mounting screws with even force on the diagonal line.

- (1) Cylinder Block
- (2) Main Bearing Case 2
- (3) Bearing Case Cover
- (4) Top Mark (上)

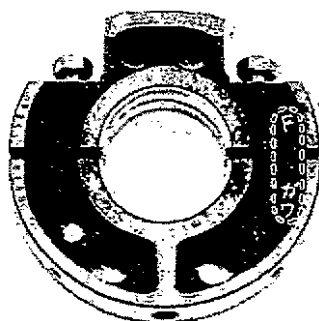
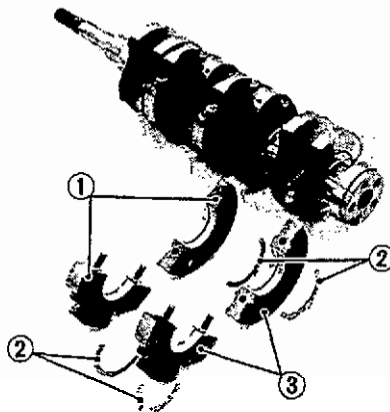

Main Bearing Case Assembly

1. Remove the two bearing case screws 1, and remove the main bearing case assembly 1 (3), being careful with the thrust bearing (2) and crankshaft bearing 2.
2. Remove the main bearing case assemblies 2, 3, as above.

(When reassembling)

- Clean the oil passage in the main bearing case.
- Apply clean engine oil on the crankshaft bearing 2 and thrust bearings.
- Install the main bearing case assemblies in the original positions. They are not interchangeable.
- When installing the main bearing case assemblies 2, 3, face the mark "Fガワ" to the flywheel.
- Be sure to install the thrust bearing with its oil groove facing outward.

- (1) Main Bearing Case Assembly 2
- (2) Thrust Bearing
- (3) Main Bearing Case Assembly 1

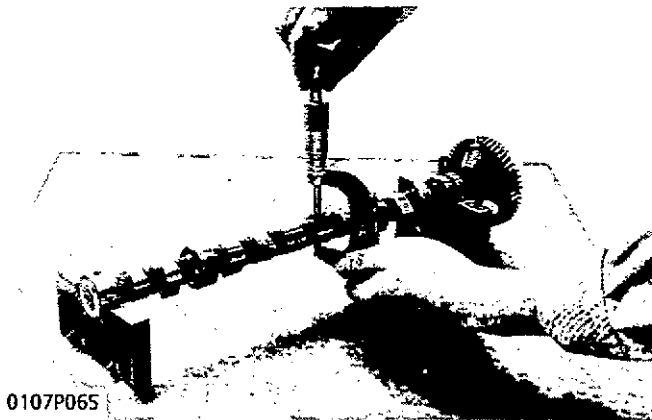

Intake and Exhaust Cam Height

1. Measure the height of the cam at its highest point with an outside micrometer.
2. If the measurement is less than the allowable limit, replace it.

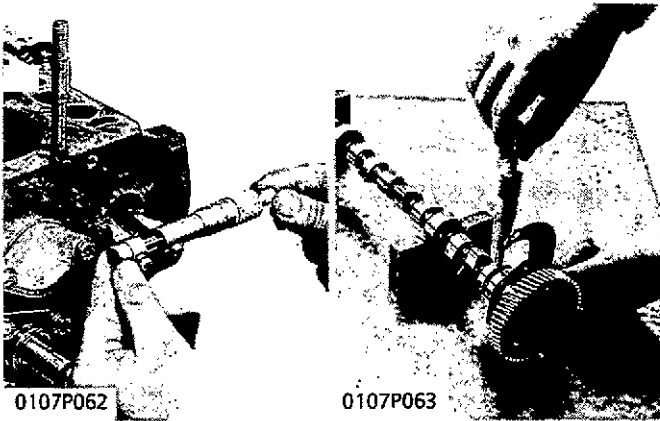

Oil Clearance of Camshaft Journal

1. Measure the camshaft journal O.D. with an outside micrometer.
2. Measure the cylinder block bore I.D. for camshaft with an inside micrometer. Calculate the oil clearance.
3. If the clearance exceeds the allowable limit, replace the camshaft.

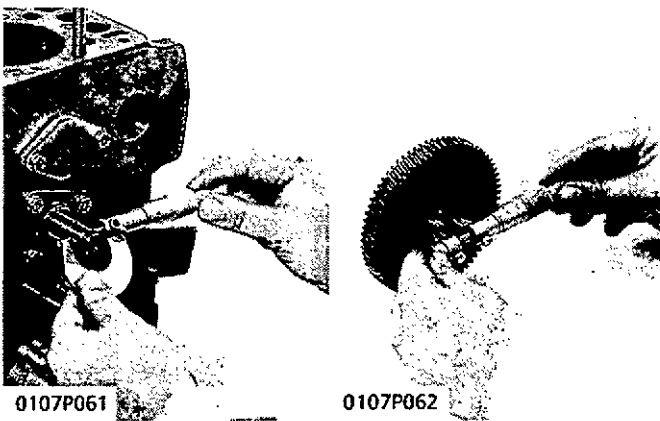

Clearance between Idle Gear Shaft and Idle Gear

Bushings

1. Measure the idle gear shaft O.D. with an outside micrometer.
2. Measure the idle gear bushings I.D. with an inside micrometer, and calculate the clearance.
3. If the clearance exceeds the allowable limit, replace the bushing.

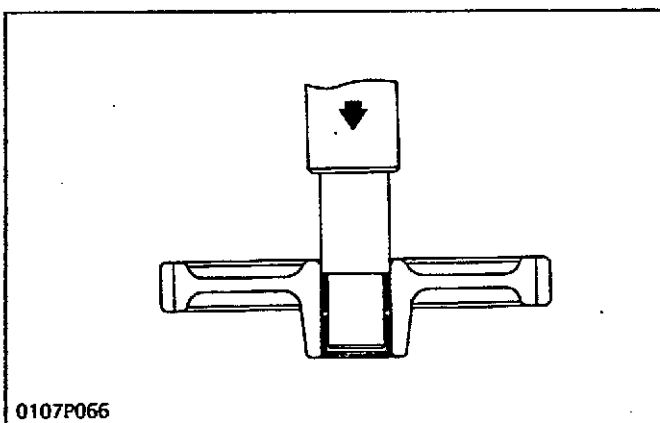

Replacing Idle Gear Bushings

1. Press the used bushings out using a idle gear bushing replacing tool.
2. Press fit new bushings.

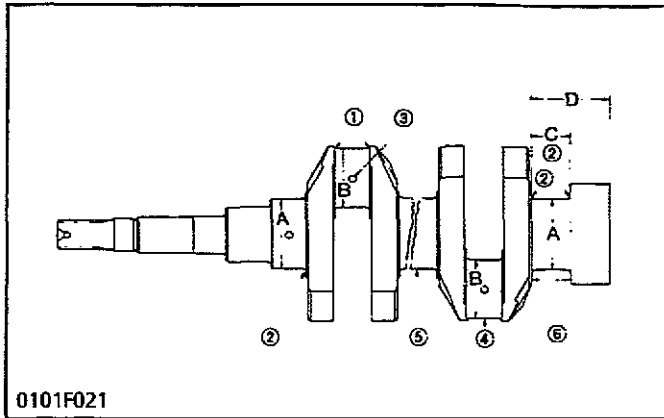

0101F021

		Dimension D
Overize	+0.2 mm +0.008 in.	48.1 to 48.3 mm 1.894 to 1.902 in.
Overize	+0.4 mm +0.016 in.	48.3 to 48.5 mm 1.902 to 1.909 in.

Undersized and Oversized Bearing

If the standard-size bearing cannot be employed due to excessive wear of the crankpin and crank journal, employ undersize or oversize bearings.

For under size or oversize bearing use, follow the precautions noted below.

● Grind the crankpin and journal with a wheel which has specified round corner and width without shoulder.

1. 3.3 to 3.7 mm (0.1300 to 0.1457 in.)
2. 2.8 to 3.2 mm (0.1102 to 0.1260 in.)
3. Be sure to chamfer the oil hole circumference to 1 to 1.5 mm (0.04 to 0.06 in.) radius with an oil stone.
4. The crankpin must be fine-finished to higher than $\nabla\nabla\nabla\nabla$ (0.4-5).
5. The crank journal must be fine-finished to higher than $\nabla\nabla\nabla$ (0.4-5).
6. The crank journal side surface must be fine-finished to higher than $\nabla\nabla\nabla$ (0.4-5).

Size	Code No.	Name of bearing	Bearing mark	Crankshaft processing dimension	
-0.2 mm -0.008 in.	15261-2391-1	Crankshaft bearing 1 (0.2 minus)	020 US	A	43.734 to 43.750 mm 1.7218 to 1.7224 in.
	15261-2393-1	Crankshaft bearing 2 (0.2 minus)			
-0.4 mm -0.016 in.	15261-2392-1	Crankshaft bearing 1 (0.4 minus)	040 US		43.534 to 43.550 mm 1.7140 to 1.7145 in.
	15261-2394-1	Crankshaft bearing 2 (0.4 minus)	040 US		
-0.2 mm -0.008 in.	15531-2297-1	Crank pin bearing (0.2 minus)	020 US	B	36.759 to 36.775 mm 1.4473 to 1.4478 in.
	15531-2298-1	Crank pin bearing (0.4 minus)	040 US		36.559 to 36.575 mm 1.4394 to 1.4399 in.
+0.2 mm +0.008 in.	15261-2395-1	Thrust bearing 1 (0.2 plus)	020 OS	C	24.40 to 24.45 mm 0.9763 to 0.9783 in.
	15261-2397-1	Thrust bearing 2 (0.2 plus)			
+0.4 mm +0.016 in.	15261-2396-1	Thrust bearing 1 (0.4 plus)	040 OS		24.80 to 24.85 mm 0.9763 to 0.9783 in.
	15261-2398-1	Thrust bearing 2 (0.4 plus)			

3 COOLING SYSTEM

CHECKING

[1] FAN BELT

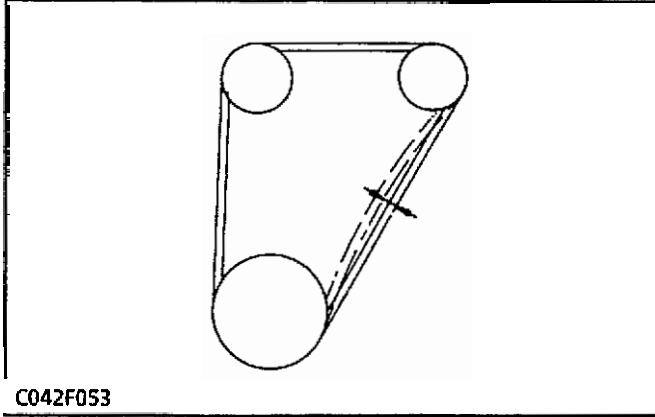

Fan Belt Tension

1. Press the fan belt between fan pulley and pulley with your finger at force of 10 kgf (98N, 22 lbs). Check if the fan belt deflection is 7 to 9 mm (0.28 to 0.35 in.)
2. If the deflection is not within the factory specifications, adjust with the tension pulley adjusting nut.

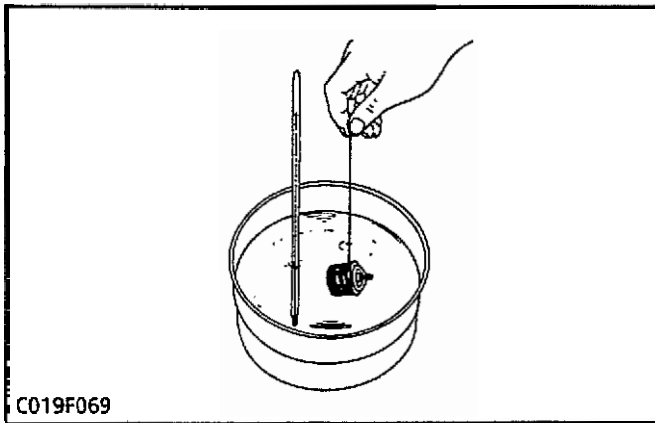

Thermostat's Valve Opening Temperature

1. Push down the thermostat valve and insert a string between the valve and the valve seat.
2. Place the thermostat and a thermometer in a container with water and gradually heat the water.
3. Hold the string to suspend the thermostat in the water. When the water temperature rises, the thermostat valve will open, allowing it to fall down from the string. Read the temperature at this moment on the thermometer.
4. Continue heating the water and read the temperature when the valve has risen by about 6 mm (0.236 in.).
5. If the measurement is not acceptable, replace the thermostat.

Thermostat's valve opening temperature	Factory spec.	80.5 to 83.5°C 176.9 to 182.3°F
Temperature at which thermostat completely opens	Factory spec.	95°C 203°F

[2] RADIATOR

⚠ CAUTION

- When removing the radiator cap, wait at least ten minutes after the engine has stopped and cooled down. Otherwise, hot water may gush out, scalding nearby people.

5 ELECTRICAL SYSTEM

CHECKING

[1] ALTERNATOR AND REGULATOR

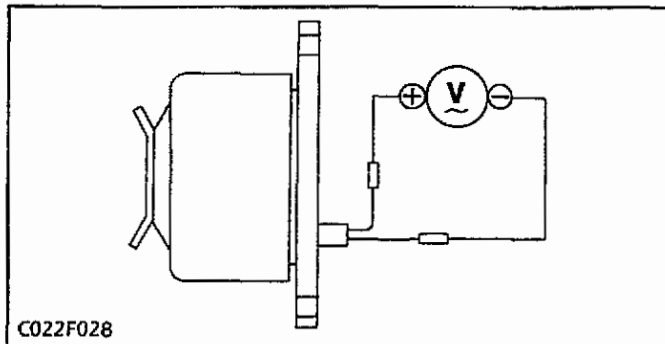

C022F028

Alternator's No-load Voltage

1. Disconnect the lead wire from the alternator.
2. Start the engine and measure the voltage generated by the alternator.

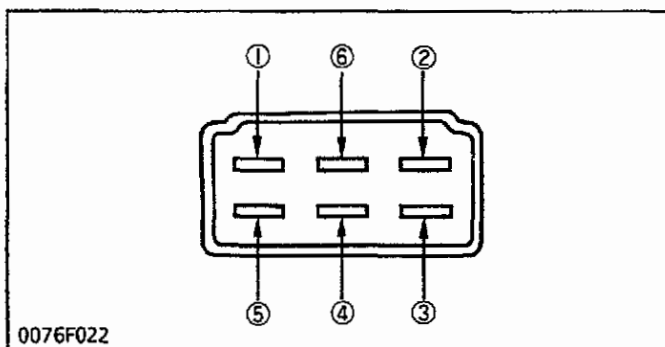

0076F022

Continuity across Regulator's Terminals

1. Remove the regulator coupler.
2. Check with a tester whether the regulator is in optimum condition or not.

NOTE

- Try to use a high-resistance tester as far as possible.
- The judgment should be as below table. "ON" if the indicator moves, otherwise "OFF".

Check Table

- | | | |
|------------|-----------|-------------|
| (1) Blue | (1) Bleu | (1) Blau |
| (2) Blue | (2) Bleu | (2) Blau |
| (3) Red | (3) Rouge | (3) Rot |
| (4) Yellow | (4) Jaune | (4) Gelb |
| (5) Green | (5) Vert | (5) Grün |
| (6) Black | (6) Noir | (6) Schwarz |

Tester -terminal	Tester + terminal	Cord colors					
		blue	blue	red	yellow	green	black
Cord colors	blue		OFF	ON	OFF	OFF	OFF
	blue	OFF		ON	OFF	OFF	OFF
	red	OFF	OFF		OFF	OFF	OFF
	yellow	ON	ON	ON		OFF	ON
	green	OFF	OFF	OFF	OFF		OFF
	black	OFF	OFF	OFF	OFF	OFF	

[2] STARTER

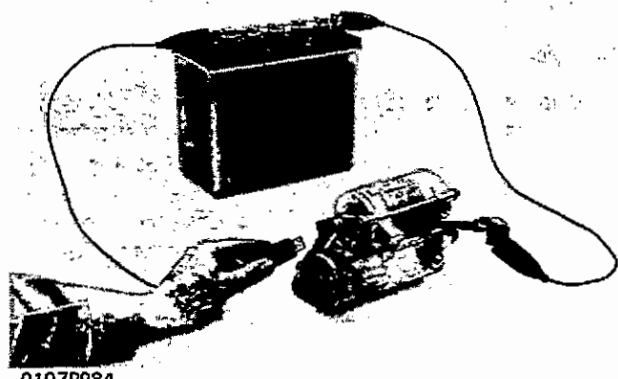

0107P084

Motor Test

1. Disconnect the connecting lead from the "C" terminal of the starter and connect a jumper lead from the connecting lead to the positive battery terminal.
2. Connect a jumper lead momentarily between the starter body and the negative battery terminal.
3. If the motor does not run, check the motor.

CLICK HERE TO **DOWNLOAD** THE COMPLETE MANUAL

- Thank you very much for reading the preview of the manual.
- You can download the complete manual from: www.heydownloads.com by clicking the link below



- Please note: If there is no response to CLICKING the link, please download this PDF first and then click on it.

CLICK HERE TO **DOWNLOAD** THE COMPLETE MANUAL