



Kawasaki

KLR650



Motorcycle Service Manual

CLICK HERE TO **DOWNLOAD** THE COMPLETE MANUAL

- Thank you very much for reading the preview of the manual.
- You can download the complete manual from: www.heydownloads.com by clicking the link below



- Please note: If there is no response to CLICKING the link, please download this PDF first and then click on it.

CLICK HERE TO **DOWNLOAD** THE COMPLETE MANUAL

General Information

Table of Contents

Before Servicing	1-2
Model Identification.....	1-7
General Specifications.....	1-8
Unit Conversion Table	1-11

Unit Conversion Table

Prefixes for Units:

Prefix	Symbol	Power
mega	M	× 1 000 000
kilo	k	× 1 000
centi	c	× 0.01
milli	m	× 0.001
micro	μ	× 0.000001

Units of Mass:

kg	×	2.205	=	lb
g	×	0.03527	=	oz

Units of Volume:

L	×	0.2642	=	gal (US)
L	×	0.2200	=	gal (IMP)
L	×	1.057	=	qt (US)
L	×	0.8799	=	qt (IMP)
L	×	2.113	=	pint (US)
L	×	1.816	=	pint (IMP)
mL	×	0.03381	=	oz (US)
mL	×	0.02816	=	oz (IMP)
mL	×	0.06102	=	cu in

Units of Force:

N	×	0.1020	=	kg
N	×	0.2248	=	lb
kg	×	9.807	=	N
kg	×	2.205	=	lb

Units of Length:

km	×	0.6214	=	mile
m	×	3.281	=	ft
mm	×	0.03937	=	in

Units of Torque:

N·m	×	0.1020	=	kgf·m
N·m	×	0.7376	=	ft·lb
N·m	×	8.851	=	in·lb
kgf·m	×	9.807	=	N·m
kgf·m	×	7.233	=	ft·lb
kgf·m	×	86.80	=	in·lb

Units of Pressure:

kPa	×	0.01020	=	kgf/cm ²
kPa	×	0.1450	=	psi
kPa	×	0.7501	=	cmHg
kgf/cm ²	×	98.07	=	kPa
kgf/cm ²	×	14.22	=	psi
cmHg	×	1.333	=	kPa

Units of Speed:

km/h	×	0.6214	=	mph
------	---	--------	---	-----

Units of Power:

kW	×	1.360	=	PS
kW	×	1.341	=	HP
PS	×	0.7355	=	kW
PS	×	0.9863	=	HP

Units of Temperature:

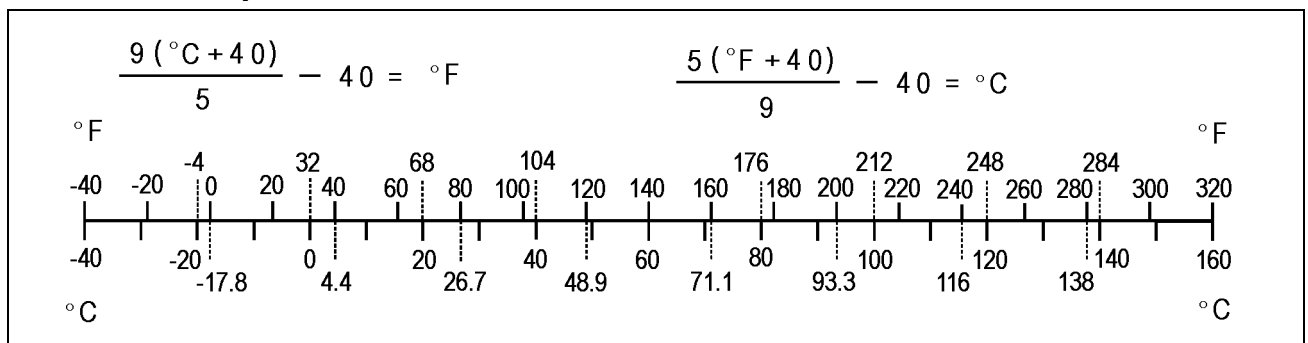

Torque and Locking Agent

Fastener	Torque			Remarks
	N·m	kgf·m	ft·lb	
Bleed Valve	7.8	0.80	69 in·lb	
Front Brake Disc Mounting Bolts	27	2.8	20	
Front Brake Light Switch Screw	1.2	0.12	11 in·lb	
Front Brake Pad Pins	17	1.7	12	
Front Caliper Holder Shaft	17	1.7	12	Si
Front Caliper Mounting Bolts	34	3.5	25	
Front Master Cylinder Clamp Bolts	8.8	0.90	78 in·lb	S
Front Master Cylinder Reservoir Cap Screws	1.5	0.15	13 in·lb	
Rear Brake Disc Mounting Bolts	27	2.8	20	
Rear Brake Pad Pins	17	1.7	12	
Rear Caliper Holder Shaft	17	1.7	12	Si
Rear Caliper Mounting Bolts	25	2.5	18	
Rear Master Cylinder Mounting Bolts	25	2.5	18	
Rear Master Cylinder Push Rod Locknut	17	1.7	12	
Rear Master Cylinder Reservoir Tank Mounting Bolt	6.9	0.70	61 in·lb	
Suspension				
Front Axle Clamp Bolts	20	2.0	15	
Front Fork Bottom Allen Bolts	30	3.0	22	L
Front Fork Top Plugs	30	3.0	22	
Lower Fork Clamp Bolts	20	2.0	15	
Lower Rear Shock Absorber Nut	98	10	72	
Rocker Arm Nut	98	10	72	
Swingarm Pivot Shaft Nut	88	9.0	65	
Tie-rod Nuts	98	10	72	
Upper Fork Clamp Bolts	20	2.0	15	AL
Upper Rear Shock Absorber Bolt	59	6.0	44	
Steering				
Brake Hose Clamp Bolt	6.9	0.70	61 in·lb	
Handlebar Clamp Bolts	25	2.5	18	S
Left Switch Housing Screws	3.5	0.36	31 in·lb	
Lower Fork Clamp Bolts	20	2.0	15	
Right Switch Housing Screws	3.5	0.36	31 in·lb	
Steering Stem Head Nut	49	5.0	36	
Steering Stem Nut	4.9	0.50	43 in·lb	
Throttle Case Screws	3.8	0.39	34 in·lb	
Upper Fork Clamp Bolts	20	2.0	15	AL
Frame				
Front Footpeg Bracket Bolts	25	2.5	18	
Lower Rear Frame Bolts	25	2.5	18	
Lower Fairing Mounting Bolts	8.8	0.90	78 in·lb	
Rear Footpeg Bracket Bolts	25	2.5	18	
Sidestand Bolt and Nut	44	4.5	33	R (1)

Periodic Maintenance Procedures

Cooling System

Coolant Level Inspection

NOTE

○ Check the level when the engine is cold (room or ambient temperature).

- Check the coolant level in the reserve tank with the motorcycle held perpendicular (Do not use the sidestand.).
 - ★ If the coolant level is lower than the “LOW” level line [A], unscrew the reserve tank cap and add coolant to the “FULL” level line [B].
- Coolant Reserve Tank Cover [C]

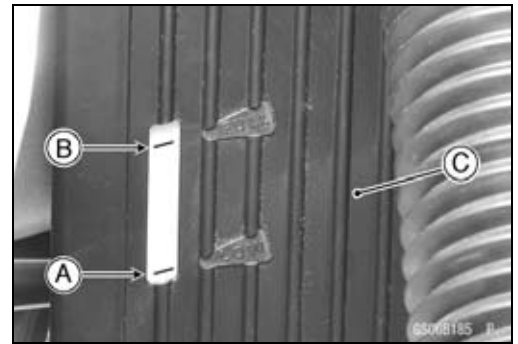

NOTICE

For refilling, add the specified mixture of coolant and soft water. Adding water alone dilutes the coolant and degrades its anticorrosion properties. The diluted coolant can attack the aluminum engine parts. In an emergency, soft water alone can be added. But the diluted coolant must be returned to the correct mixture ratio within a few days. If coolant must be added often or the reservoir tank has run completely dry, there is probably leakage in the cooling system. Check the system for leaks. Coolant ruins painted surfaces. Immediately wash away any coolant that spills on the frame, engine, wheels or other painted parts.

Radiator Hose and Pipe Inspection (coolant leak, damage, installation condition)

- The high pressure inside the radiator hose can cause coolant to leak [A] or the hose to burst if the line is not properly maintained.
- Visually inspect the hoses for signs of deterioration. Squeeze the hoses. A hose should not be hard and brittle, nor should it be soft or swollen.
- ★ Replace the hose if any fraying, cracks [B] or bulges [C] are noticed.
- Check that the hoses are securely connected and water hose clamp screws are tightened correctly.

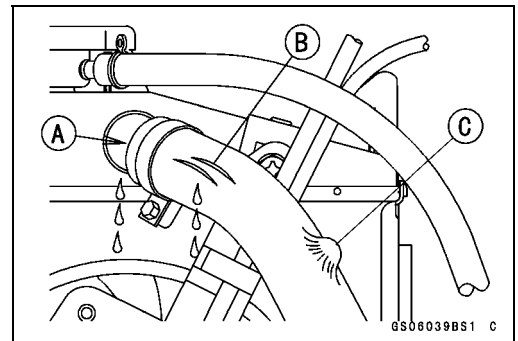

Engine Top End

Valve Clearance Inspection

NOTE

○ Valve clearance must be checked and adjusted when the engine is cold (room temperature).

Periodic Maintenance Procedures

Drive Train

Drive Chain Lubrication Condition Inspection

- If a special lubricant is not available, a heavy oil such as SAE 90 is preferred to a lighter oil because it will stay on the chain longer and provide better lubrication.
- If the chain appears especially dirty, clean it before lubrication.

NOTICE

The O-rings between the side plates seal in the lubricant between the pin and the bushing. To avoid damaging the O-rings and resultant loss of lubricant, observe the following rules.

Use only kerosene or diesel oil for cleaning of the O-ring of the drive chain. Any other cleaning solution such as gasoline or trichloroethylene will cause deterioration and swelling of the O-ring. Immediately blow the chain dry with compressed air after cleaning. Complete cleaning and drying the chain within 10 minutes.

- Apply oil to the sides of the rollers so that oil will penetrate to the rollers and bushings. Apply the oil to the O-rings so that the O-rings will be coated with oil.
- Wipe off any excess oil.
 - Oil Applied Areas [A]
 - O-rings [B]

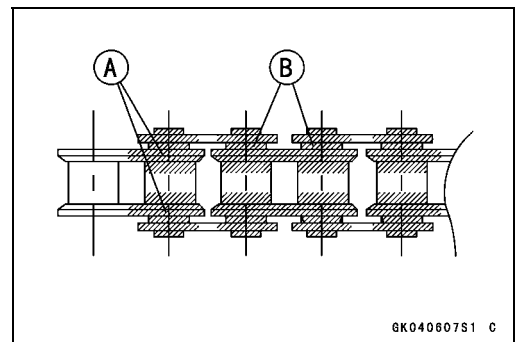

Drive Chain Slack Inspection

NOTE

- Check the slack with the motorcycle setting on its side-stand.
- Clean the chain if it is dirty, and lubricate it if it appears dry.

- Check the wheel alignment (see Wheel Alignment Inspection).
- Rotate the rear wheel to find the position where the chain is tightest.
- Measure the vertical movement (chain slack) [A] midway between the sprockets.
- ★ If the chain slack exceeds the standard, adjust it.

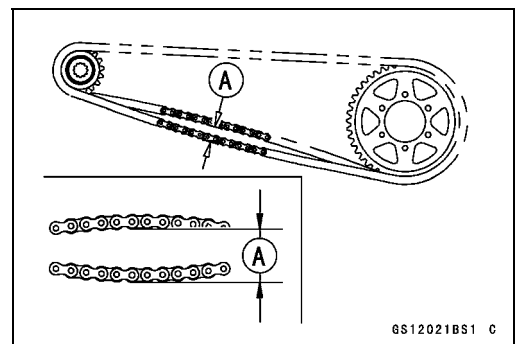

Chain Slack

Standard: 35 ~ 45 mm (1.4 ~ 1.8 in.)

Periodic Maintenance Procedures

Tie-Rod Operation Inspection

- Pump the tail grip down and up 4 or 5 times, and inspect the smooth stroke.
- ★ If the tie-rods [A] do not smoothly stroke or noise is found, inspect the fasteners and tie-rod bearings (see Rocker Arm/Tie-Rod Bearing, Sleeve Inspection in the Suspension chapter).



Tie-Rod Bearing Lubrication

- Remove the tie-rods (see Tie-Rod Removal in the Suspension chapter).
- Lubricate the tie-rod bearings in the same way as rocker arm bearings (see Rocker Arm Bearing Lubrication).
- Install the tie-rods (see Tie-Rod Installation in the in the Suspension chapter).

Swingarm Pivot Lubrication

- Remove the swingarm (see Swingarm Removal in the Suspension chapter).
- Remove the sleeves [A].
- Using a high-flash point solvent, clean the old grease out of the needle bearings [B].
- Apply plenty of grease to the inner surface of the needle bearings.
- Apply thin coat of grease to the lips of the grease seals [C].
- Install the swingarm (see Swingarm Installation in the Suspension chapter).

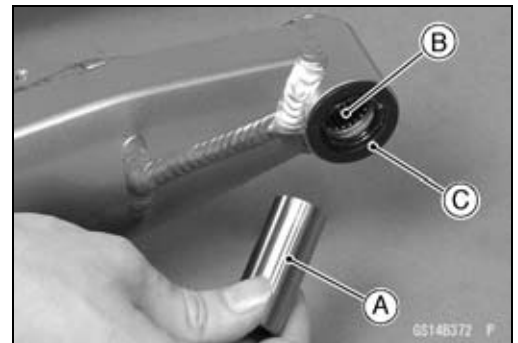

Steering System

Steering Play Inspection

- Raise the front wheel off the ground with jack.
 - **Special Tools - Jack: 57001-1238**
- With the front wheel pointing straight ahead, alternately tap each end of the handlebar. The front wheel should swing fully left and right from the force of gravity until the fork hits the stop.
- ★ If the wheel binds or catches before the stop, the steering is too tight.
- Feel for steering looseness by pushing and pulling the forks.
- ★ If you feel looseness, the steering is too loose.



NOTE

- *The cables and wiring will have some effect on the motion of the fork which must be taken into account.*
- *Be sure the leads and cables are properly routed.*
- *The bearings must be in good condition and properly lubricated in order for any test to be valid.*

Periodic Maintenance Procedures

Replacement Parts

Air Cleaner Element Replacement

NOTE

- *In dusty areas, the element should be replaced more frequently than the recommended interval.*
- *After riding through rain or on muddy roads, the element should be replaced immediately.*

⚠ WARNING

If dirt or dust is allowed to pass through into the carburetor, the throttle may become stuck, possibly causing accident. Replace the air cleaner element according to the maintenance chart.

- Remove:
 - Right Side Cover (see Side Cover Removal in the Frame chapter)
 - Screw [A]
 - Air Cleaner Cap [B]



- Remove:
 - Wing Bolt [A]
 - Air Cleaner Element [B]
- Stuff pieces of lint-free, clean cloth into the air cleaner housing to keep dirt out of the carburetor and engine.

NOTICE

If dirt gets through into the engine, excessive engine wear and possibly engine damage will occur.



- Separate the frame [A] from the element [B].
- Discard the air cleaner element.

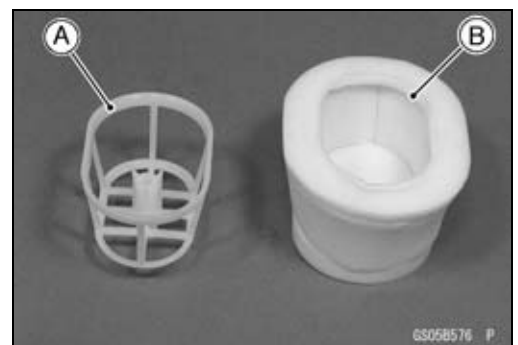

Periodic Maintenance Procedures

Master Cylinder Assembly

- Before assembly, clean all parts including the master cylinder with brake fluid or alcohol.

NOTICE

Except for the disc pads and disc, use only disc brake fluid, isopropyl alcohol, or ethyl alcohol for cleaning brake parts. Do not use any other fluid for cleaning these parts. Gasoline, engine oil, or any other petroleum distillate will cause deterioration of the rubber parts. Oil spilled on any part will be difficult to wash off completely, and will eventually deteriorate the rubber used in the disc brake.

- Apply brake fluid to the new parts and to the inner wall of the cylinder.
- Take care not to scratch the piston or the inner wall of the cylinder.
- Apply silicone grease to the brake lever pivot bolt.
- Tighten the brake lever pivot bolt and the locknut.

Torque - Brake Lever Pivot Bolt: 5.9 N·m (0.60 kgf·m, 52 in·lb)

Brake Lever Pivot Bolt Locknut: 5.9 N·m (0.60 kgf·m, 52 in·lb)

Front Master Cylinder Reservoir Cap Screws: 1.5 N·m (0.15 kgf·m, 13 in·lb)

Caliper Rubber Parts Replacement

Front Caliper Disassembly

- Remove:
 - Front Caliper (see Front Caliper Removal in the Brakes chapter)
 - Brake Pads (see Front Brake Pad Removal in the Brakes chapter)
- Using compressed air, remove the pistons.
 - Cover the piston area with a clean, thick cloth [A].
 - Blow compressed air [B] into the hole for the banjo bolt to remove the piston.

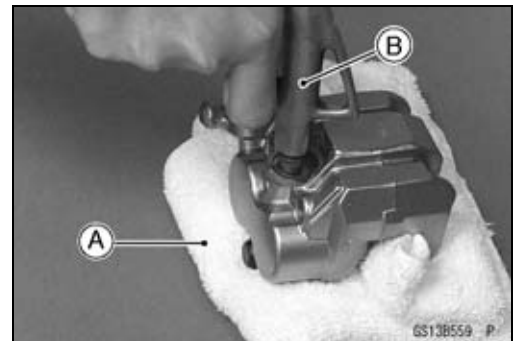

⚠ WARNING

The piston in the brake caliper can crush hands and fingers. Never place your hand or fingers in front of the piston.

- Pull out the pistons by hand.
- Remove the dust seals [A] and fluid seals [B].
- Remove the bleed valve [C] and rubber cap [D].

NOTE

○ If compressed air is not available, with the brake hose still attached, apply the brake lever to remove the piston. The remaining process is as described above.

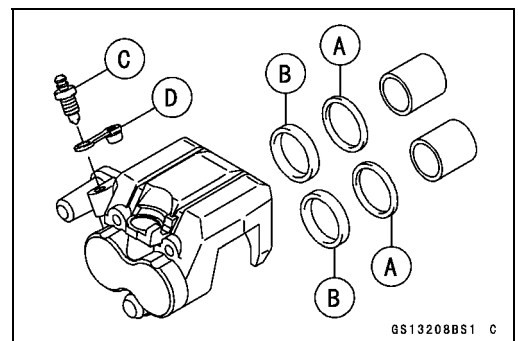

Exploded View

No.	Fastener	Torque			Remarks
		N·m	kgf·m	ft·lb	
1	Air Cleaner Duct Clamp Screw	2.0	0.20	18 in·lb	
2	Fuel Tap Diaphragm Cover Screws	1.0	0.10	9.0 in·lb	
3	Fuel Tap Bolts	2.5	0.25	22 in·lb	
4	Fuel Tap Lever Plate Screws	0.8	0.08	7 in·lb	
5	Air Cleaner Housing Bolt	8.8	0.90	78 in·lb	

6. Vacuum Switch Valve

7. Air Cleaner Housing

8. Air Cleaner Element

9. CAL Model

10. Other than CAL Model

11. Other than AU Model

AD: Apply adhesive.

R: Replacement Parts

Carburetor

Idle Speed Inspection

- Refer to the Idle Speed Inspection in the Periodic Maintenance chapter.

Idle Speed Adjustment

- Refer to the Idle Speed Adjustment in the Periodic Maintenance chapter.

Pilot Screw Adjustment (AU Model)

NOTE

○ For the other than Australia model, there is plug on the pilot screw.

- ★ If the engine idle is still not stable, adjust the pilot screw to obtain the proper idle speed using the pilot screw adjuster [A].

Special Tool - Pilot Screw Adjuster, B: 57001-1240

- Turn in the pilot screw fully but not tightly, and then back it out the specified turns. To set the screw to its original position.

Pilot Screw Setting: 1 5/8 turns out

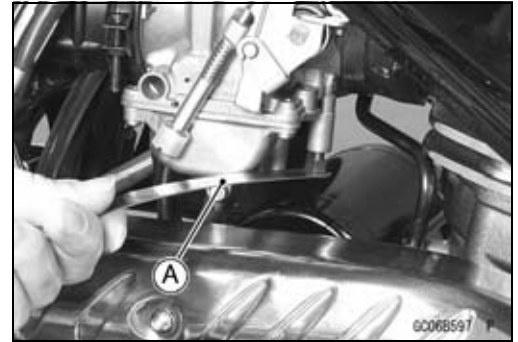

NOTICE

Does not over-tighten the pilot screw. It could be damaged, requiring replacement.

NOTE

○ The standard number of turns the pilot screw must be backed out varies by carburetor. The values given in the specifications should be used only when the number of the original back out turns is unavailable.

Service Fuel Level Inspection

⚠ WARNING

Gasoline is extremely flammable and can be explosive under certain conditions. Turn the ignition switch OFF. Do not smoke. Make sure the area is well-ventilated and free from any source of flame or sparks; this includes any appliance with a pilot light.

Carburetor

- Turn the throttle cable pulley [A] to check that the throttle valve [B] moves smoothly and returns by spring force.
- ★ If the throttle valve does not move smoothly, replace the carburetor.

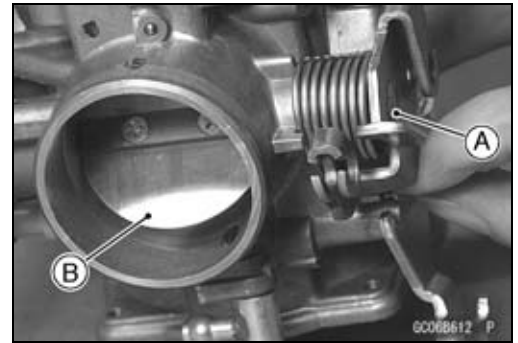

- Disassemble the carburetor (see Carburetor Disassembly).
- Clean the carburetor (see Carburetor Cleaning).
- Check that all O-rings and diaphragms of the carburetor are in good condition.
- ★ If the O-ring or the diaphragm is not in good condition, replace it.
- Check the plastic tip [A] of the float valve needle [B]. It should be smooth, without any grooves, scratches, or tears.
- ★ If the plastic tip is damaged [C], replace the needle.
- Push the rod [D] into the valve needle with your finger, and then release it [E].
- ★ If the rod does not spring out, replace the float valve needle.

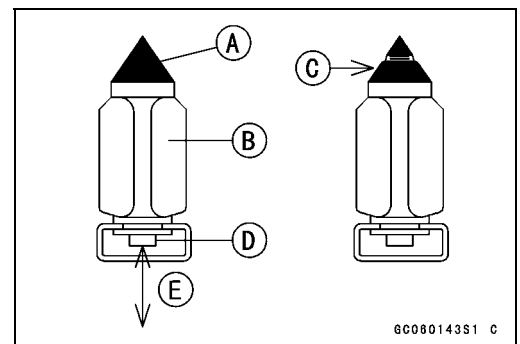

- Check the tapered portion [A] of the pilot screw [B] for wear or damage.
- ★ Replace the pilot screw if it is worn or damaged on the tapered portion, or it will prevent the engine from idling smoothly.

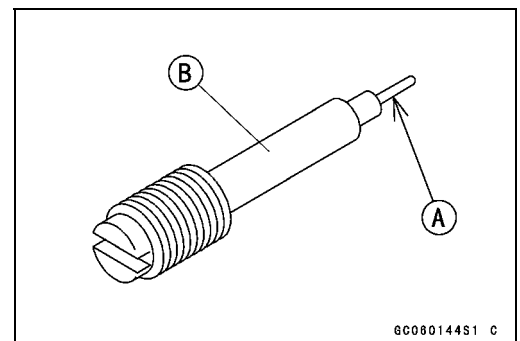

- Check that the vacuum piston [A] operates smoothly in the carburetor body.
- ★ If the vacuum piston does not operate smoothly, or if loosened in the carburetor body, replace the piston or the carburetor.

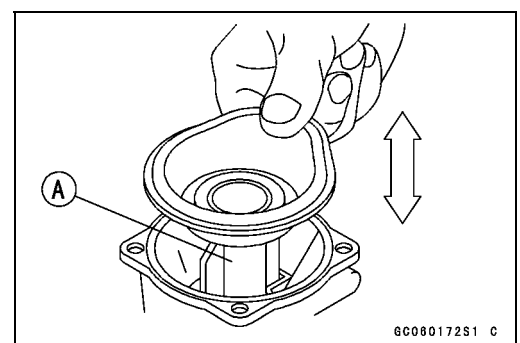

Cooling System

Table of Contents

Exploded View.....	4-2
Coolant Flow Chart.....	4-4
Specifications	4-6
Special Tool and Sealant.....	4-7
Coolant.....	4-8
Coolant Deterioration Inspection.....	4-8
Coolant Level Inspection.....	4-8
Coolant Draining	4-8
Coolant Filling	4-8
Pressure Testing	4-8
Cooling System Flushing	4-9
Coolant Filter Cleaning (AU Model)	4-9
Coolant Valve Inspection (AU Model)	4-9
Coolant Reserve Tank Removal/Installation	4-9
Water Pump.....	4-10
Water Pump Removal.....	4-10
Water Pump Installation.....	4-10
Water Pump Inspection.....	4-11
Water Pump Impeller Disassembly/Assembly	4-11
Water Pump Impeller Inspection.....	4-11
Mechanical Seal Inspection	4-11
Mechanical Seal Replacement	4-12
Water Pump Oil Seal Replacement	4-12
Radiator.....	4-13
Radiator Fan Removal.....	4-13
Radiator Fan Installation.....	4-13
Radiator Removal	4-13
Radiator Installation	4-13
Radiator Inspection.....	4-14
Radiator Cap Inspection	4-14
Radiator Filler Neck Inspection	4-15
Thermostat	4-16
Thermostat Removal.....	4-16
Thermostat Installation.....	4-16
Thermostat Inspection	4-17
Hose and Pipes	4-18
Hose Installation	4-18
Hose Inspection	4-18
Radiator Fan Switch, Water Temperature Sensor	4-19
Radiator Fan Switch Removal/Installation	4-19
Radiator Fan Switch Inspection	4-19
Water Temperature Sensor Removal/Installation	4-19
Water Temperature Sensor Inspection	4-19

Water Pump

- Install the water hoses [A] and clamps [B] as shown.
White Marks [C]
- Tighten the water hose clamp screw securely.
- Fill the radiator with the coolant (see Coolant Change in the Periodic Maintenance chapter).

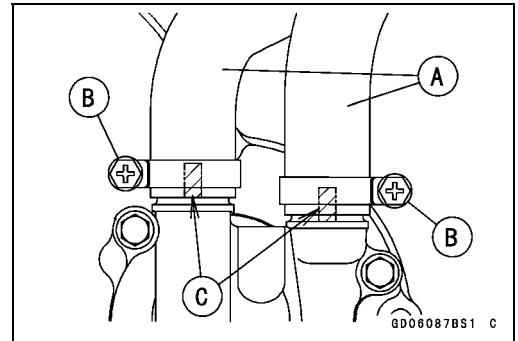

Water Pump Inspection

- Remove the engine guard (see Engine Guard Removal in the Frame chapter).
- Check the drainage outlet passage [A] at the bottom of the water pump body for coolant leaks.
Bottom View [B]
Front [C]
- ★ If the mechanical seal is damaged, the coolant leaks through the seal and drains through the passage. Replace the mechanical seal unit.

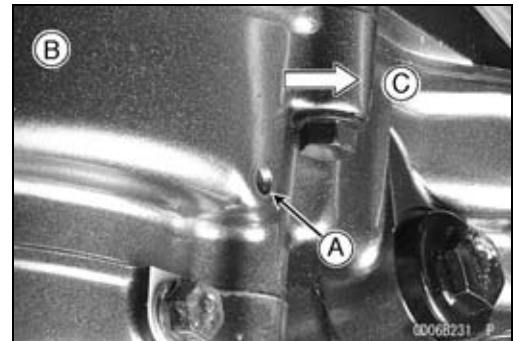

Water Pump Impeller Disassembly/Assembly

- Remove the water pump impeller (see Water Pump Removal).
- The sealing seat and rubber seal may be removed easily by hand.
- Apply coolant around the surfaces of the rubber seal and sealing seat.
- Install the rubber seal [A] and sealing seat [B] into the impeller by pressing them by hand until the seat stops at the bottom of the hole.
- Install the water pump impeller (see Water Pump Installation).

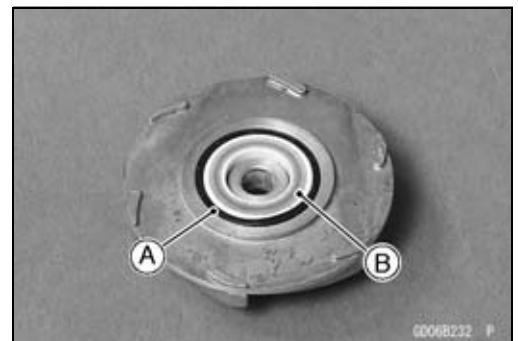

Water Pump Impeller Inspection

- Remove the water pump cover (see Water Pump Removal).
- Visually inspect the water pump impeller [A].
- ★ If the surface is corroded or if the blades are damaged, replace the impeller.



Mechanical Seal Inspection

- Remove the impeller (see Water Pump Removal).
- Visually inspect the mechanical seal.
- ★ If any one of the parts is damaged, replace the mechanical seal as a unit.
- The sealing seat and rubber seal may be removed easily by hand.
Impeller Sealing Seat Surface [A]
Rubber Seal [B]
Mechanical Seal Diaphragm [C]

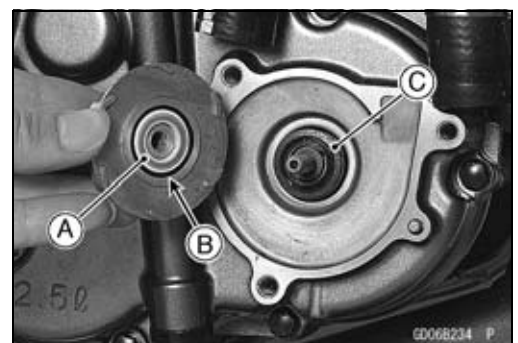

Engine Top End

Table of Contents

Exploded View	5-2	Valve Clearance Inspection	5-31
Exhaust System Identification	5-8	Valve Removal	5-31
Specifications	5-10	Valve Installation	5-31
Special Tools and Sealant	5-12	Valve Guide Removal	5-31
Clean Air System (Other than AU Model).....	5-15	Valve Guide Installation	5-32
Vacuum Switch Valve Removal ...	5-15	Valve/Valve Guide Clearance Measurement (Wobble Method)	5-33
Vacuum Switch Valve Installation	5-15	Valve Seat Inspection	5-33
Vacuum Switch Valve Test	5-15	Valve Seat Repair	5-34
Clean Air System Hose Inspection.....	5-16	Cylinder and Piston	5-38
Cylinder Head Cover	5-17	Cylinder Removal.....	5-38
Cylinder Head Cover Removal	5-17	Piston Removal.....	5-38
Cylinder Head Cover Installation .	5-17	Cylinder and Piston Installation....	5-39
Camshaft Chain Tensioner	5-19	Cylinder Wear Inspection.....	5-41
Camshaft Chain Tensioner Removal.....	5-19	Piston Wear Inspection	5-41
Camshaft Chain Tensioner Installation	5-19	Piston/Cylinder Clearance Inspection.....	5-41
Camshaft	5-21	Cylinder Boring and Honing	5-42
Camshaft Removal	5-21	Piston Ring/Ring Groove Clearance Inspection	5-42
Camshaft Installation	5-22	Piston Ring Groove Width Inspection.....	5-43
Camshaft Chain Removal	5-24	Piston Ring Thickness Inspection	5-43
Camshaft Chain Installation	5-24	Piston Ring End Gap Measurement	5-43
Camshaft and Camshaft Cap Wear.....	5-25	Carburetor Holder.....	5-44
Camshaft Runout.....	5-26	Carburetor Holder Removal	5-44
Cam Wear.....	5-26	Carburetor Holder Installation	5-44
Cylinder Head.....	5-27	Muffler.....	5-45
Cylinder Compression Measurement	5-27	Exhaust Pipe Removal.....	5-45
Cylinder Head Removal	5-28	Muffler Body Removal.....	5-46
Cylinder Head Installation	5-29	Exhaust Pipe, Muffler Body Installation	5-46
Cylinder Head Warp Inspection ...	5-30	Spark Arrester Cleaning (US and CA Models)	5-46
Valves	5-31		

Specifications

Item	Standard	Service Limit
Outside diameter:		
Exhaust	31.9 ~ 32.1 mm (1.256 ~ 1.264 in.)	— — —
Inlet	36.9 ~ 37.1 mm (1.453 ~ 1.461 in.)	— — —
Valve spring free length:		
Inner	37.6 mm (1.480 in.)	36.2 mm (1.425 in.)
Outer	40.5 mm (1.594 in.)	39.0 mm (1.535 in.)
Cylinder, Piston		
Cylinder Inside Diameter	100.000 ~ 100.012 mm (3.9370 ~ 3.9375 in.)	100.10 mm (3.9409 in.)
Piston Diameter	99.942 ~ 99.957 mm (3.9347 ~ 3.9353 in.)	99.79 mm (3.929 in.)
Piston/cylinder Clearance	0.043 ~ 0.070 mm (0.0017 ~ 0.0028 in.)	— — —
Oversize Piston and Rings	+0.5 mm (0.020 in.), + 1.0 mm (0.040 in.)	— — —
Piston Ring/groove Clearance:		
Top	0.03 ~ 0.07 mm (0.0012 ~ 0.0028 in.)	0.17 mm (0.0067 in.)
Second	0.02 ~ 0.06 mm (0.0008 ~ 0.0024 in.)	0.16 mm (0.0063 in.)
Piston Ring Groove Width:		
Top	1.22 ~ 1.24 mm (0.0480 ~ 0.0488 in.)	1.32 mm (0.0520 in.)
Second	1.21 ~ 1.23 mm (0.0476 ~ 0.0484 in.)	1.31 mm (0.0516 in.)
Piston Ring Thickness:		
Top	1.17 ~ 1.19 mm (0.0461 ~ 0.0469 in.)	1.10 mm (0.0433 in.)
Second	1.17 ~ 1.19 mm (0.0461 ~ 0.0469 in.)	1.10 mm (0.0433 in.)
Piston Ring End Gap:		
Top		
(KL650E8 Early Model)	0.20 ~ 0.35 mm (0.0079 ~ 0.0138 in.)	0.7 mm (0.03 in.)
(KL650E8 Late Model ~ KL650EC)	0.30 ~ 0.40 mm (0.0118 ~ 0.0158 in.)	0.7 mm (0.03 in.)
Second	0.40 ~ 0.55 mm (0.016 ~ 0.022 in.)	0.9 mm (0.04 in.)
Oil	0.20 ~ 0.70 mm (0.0079 ~ 0.028 in.)	1.0 mm (0.039 in.)

Camshaft

Camshaft Removal

- Remove:
 - Timing Inspection Cap [A]
 - Alternator Rotor Bolt Cap [B]
- Special Tool - Filler Cap Driver: 57001-1454**

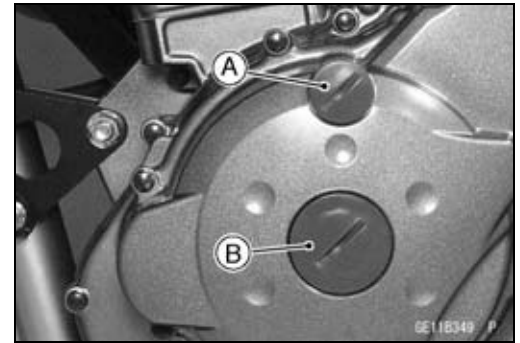

- First, bring the piston to the TDC (of either the compression or exhaust stroke).
- Place a wrench over the alternator rotor bolt and turn it counterclockwise to align the TDC mark [A] with the center of the groove [B] of the inspection hole.

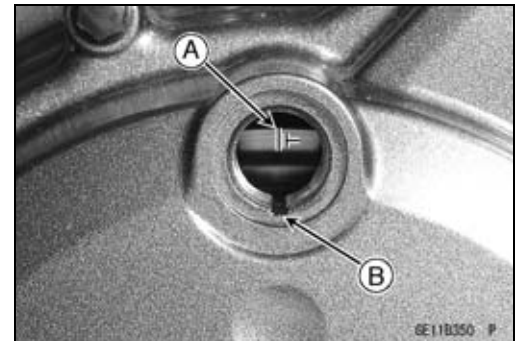

- Remove:
 - Cylinder Head Cover (see Cylinder Head Cover Removal).
 - Camshaft Chain Tensioner (see Camshaft Chain Tensioner Removal).
 - Camshaft Cap Bolts [A]
 - Camshaft Caps [B]
 - Oil Pipe [C]
- Staff a clean cloth into the camshaft chain tunnel to keep any parts from dropping into the crankcase.

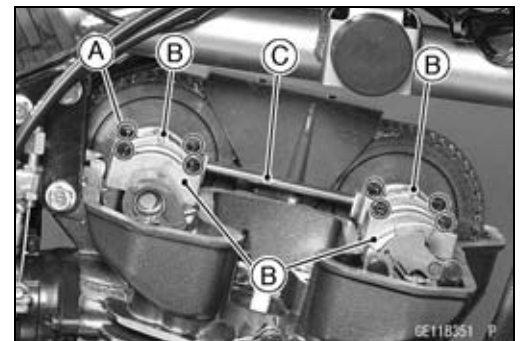

- Remove:
 - Upper Camshaft Chain Guide Bolts [A]
 - Upper Camshaft Chain Guide [B]

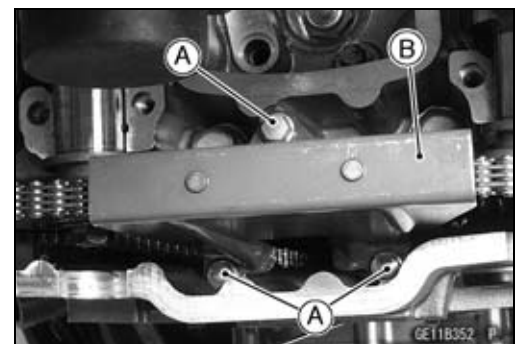

- Disengage the camshafts [A] from camshaft chain [B].

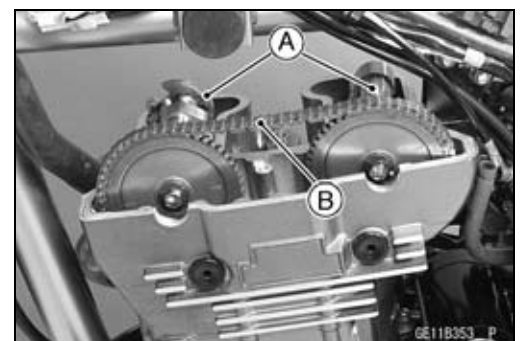

Valves

Valve Clearance Inspection

- Refer to the Valve Clearance Inspection in the Periodic Maintenance chapter.

Valve Removal

- Remove the cylinder head (see Cylinder Head Removal).
- Remove the valve lifter and the shim from the valve.

NOTE

- Use the valve spring compressor assembly and the adapter to press down the valve spring retainer.

Special Tools - Valve Spring Compressor Assembly: 57001-241 [A]

Valve Spring Compressor Adapter, ϕ 29.5: 57001-1078 [B]

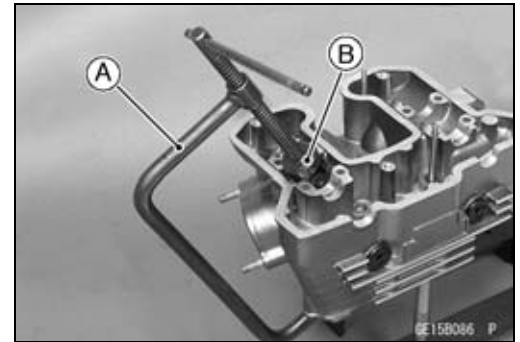

Valve Installation

NOTICE

Do not lap the valve to the valve seat, using the grinding compound. It will come off oxide film treated surface of the valve.

- Visually inspect the valve surface.
- ★ If the surface is damaged, replace it.
- Replace the oil seal [C] with a new part.
- Apply a thin coat of molybdenum disulfide grease to the valve stem [A] before installing the valve.
- Check to make sure that the valve moves up and down smoothly.
- Check to make sure that the valve and the valve seat are making proper contact.
- Install the inner valve spring [D] and outer valve spring [E] so that the closed coil end faces the spring seat [B].
- Compress the valve spring to install the split keepers [G] in order to secure the spring retainer [F] in place.

Special Tools - Valve Spring Compressor Assembly: 57001-241

Valve Spring Compressor Adapter, ϕ 29.5: 57001-1078

- The shim [I] must be installed with its thickness indication facing down towards the retainer.
- Apply engine oil to the valve lifter [H] surface, and install it.

Valve Guide Removal

- Remove:
 - Valve (see Valve Removal)
 - Oil Seal
 - Spring Seat
- Heat the area around the valve guide up to 120 ~ 150°C (248 ~ 302°F).

NOTICE

Do not heat the cylinder head with a torch. This will warp the cylinder head. Soak the cylinder head and heat the oil.

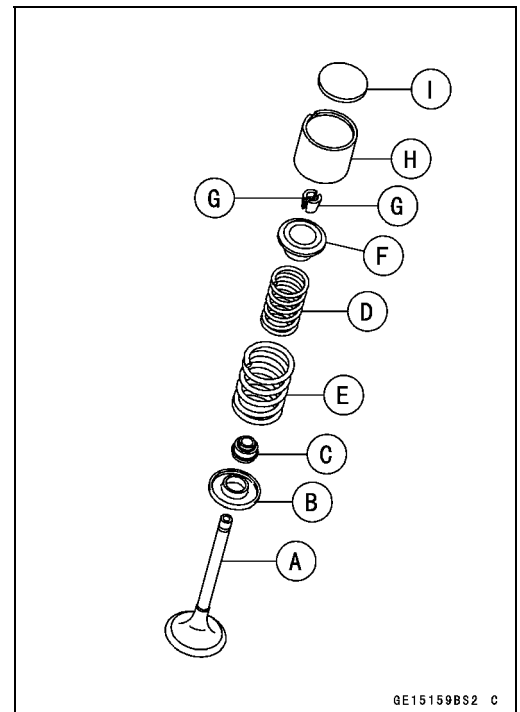

Cylinder and Piston

Cylinder Wear Inspection

- Since there is a difference in cylinder wear in different directions, take a side-to-side and a front-to-back measurement at each of the three locations (total of six measurements) shown in the figure.

10 mm (0.39 in.) [A]

55 mm (2.2 in.) [B]

20 mm (0.79 in.) [C]

- ★ If any of the cylinder inside diameter measurements exceeds the service limit, replace the cylinder.

Cylinder Inside Diameter

Standard: 100.000 ~ 100.012 mm (3.9370 ~ 3.9375 in.) (less than 0.01 mm (0.0004 in.) difference between any two measurements)

Service Limit: 100.10 mm (3.9409 in.) (less than 0.05 mm (0.0020 in.) difference between any two measurements)

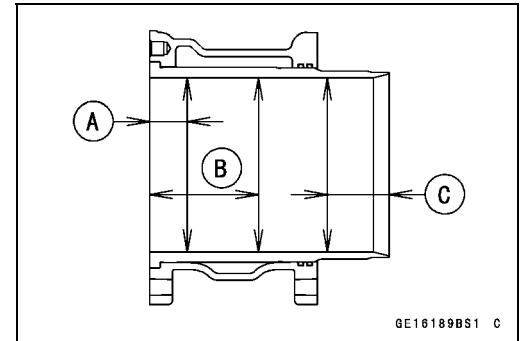

Piston Wear Inspection

- Using a micrometer, measure the outside diameter [A] of each piston 10 mm (0.39 in.) [B] up from the bottom of the piston at a right angle to the direction of the piston pin.

- ★ If the pistons outside diameter is smaller than the service limit, replace the piston.

Piston Diameter

Standard: 99.942 ~ 99.957 mm (3.9347 ~ 3.9353 in.)

Service Limit: 99.79 mm (3.929 in.)

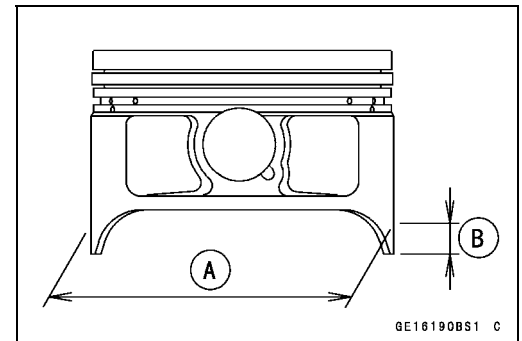

Piston/Cylinder Clearance Inspection

- Subtract the piston diameter from the cylinder inside diameter to get the piston/cylinder clearance.

Piston/Cylinder Clearance

Standard: 0.043 ~ 0.070 mm (0.0017 ~ 0.0028 in.)

- ★ If the piston/cylinder clearance is less than the specified range, use a smaller piston or increase the cylinder inside diameter by honing.
- ★ If the piston/cylinder clearance is greater than specified range, use a larger piston.
- ★ If only a piston is replaced, the clearance may exceed the standard slightly. But it must not be less than the minimum limit in order to prevent piston seizure.

Special Tool

**Clutch Holder:
57001-1243**

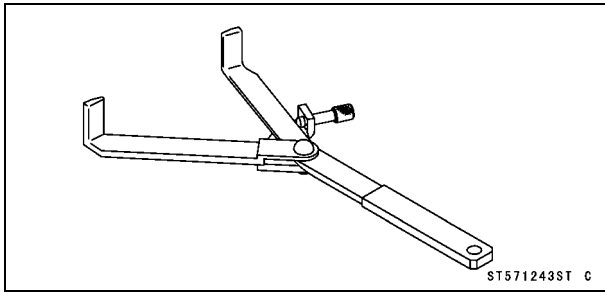

ENGINE LUBRICATION SYSTEM 7-3

Exploded View

No.	Fastener	Torque			Remarks
		N·m	kgf·m	ft·lb	
1	Oil Filter Cap Bolts	6.9	0.70	61 in·lb	
2	Oil Pressure Relief Valve	15	1.5	11	L
3	Oil Filler Cap	–	–	–	Hand-tighten
4	Oil Pipe Banjo Bolts	20	2.0	15	
5	Oil Pipe Bolt	8.8	0.90	78 in·lb	S
6	Engine Oil Feed Fitting Bolts	8.8	0.90	78 in·lb	
7	Engine Oil Drain Bolt	29	3.0	21	
8	Oil Pump Mounting Screws	4.4	0.45	39 in·lb	
9	Oil Pump Cover Screw	4.2	0.43	37 in·lb	L
10	Oil Passage Plug	25	2.5	18	

EO: Apply engine oil.

G: Apply grease.

L: Apply a non-permanent locking agent.

R: Replacement Parts

S: Follow the specified tightening sequence.

Oil Pressure Measurement

Oil Pressure Measurement

- Remove:
 - Engine Guard (see Engine Guard Removal in the Frame chapter)
 - Oil Passage Plug [A]

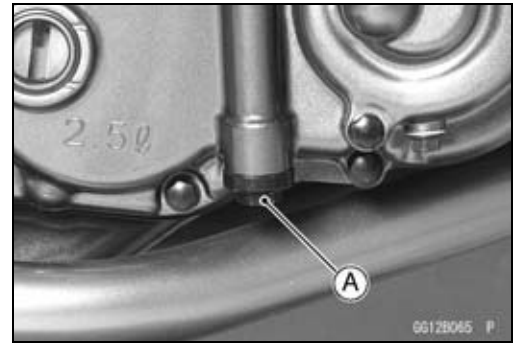

- Attach the adapter [A] and gauge [B] to the plug hole.
 - Special Tools - Oil Pressure Gauge, 10 kgf/cm²: 57001-164**
 - Oil Pressure Gauge Adapter, M10 × 1.25: 57001-1182**

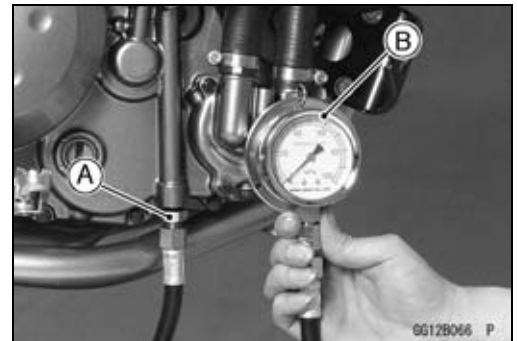

- Start the engine and warm up the engine.
- Run the engine at the specified speed, and read the oil pressure gauge.
- ★ If the oil pressure is much lower than the standard, check the oil pump and relief valve.
- ★ If the reading is much higher than the standard, check the oil screen and oil filter first, then oil passages for clogging.

Oil Pressure

Standard: 78 ~ 147 kPa (0.8 ~ 1.5 kgf/cm², 11 ~ 21 psi)
 at 4 000 r/min (rpm), oil temperature 90°C (194°F)

- Stop the engine.
- Remove the oil pressure gauge and adapter.

⚠ WARNING

Hot oil can cause severe burns. Beware of hot engine oil that will drain through the oil passage when the gauge adapter is removed.

- Replace the O-ring of the oil passage plug.
- Apply grease to the new O-ring, and install the oil passage plug.

Torque - Oil Passage Plug: 25 N·m (2.5 kgf·m, 18 ft·lb)

Engine Removal/Installation

- Apply non-permanent locking agent to the threads of the upper engine mounting bolt [A].
- Install the bracket so that the hook portion [B] faces right side of the motorcycle.
- Attach the hook portion to the upper engine bracket.
- Tighten:
Torque - Upper Engine Mounting Bolt: 25 N·m (2.5 kgf·m, 18 ft·lb)

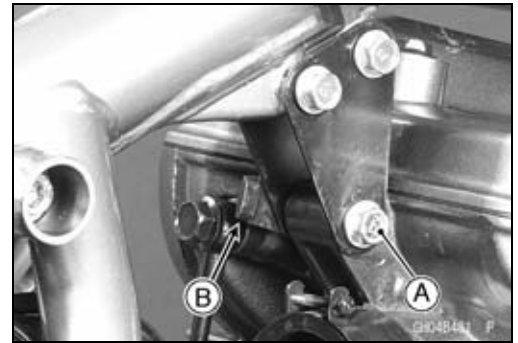

- Run the leads, cables, and hoses correctly (see Cable, Wire, and Hose Routing section in the Appendix chapter).
- Install the removed parts (see appropriate chapters).
- Adjust:
 - Throttle Cables (see Throttle Control System Inspection in the Periodic Maintenance chapter)
 - Choke Cable (see Choke Operation Inspection in the Periodic Maintenance chapter)
 - Clutch Cable (see Clutch Operation Inspection in the Periodic Maintenance chapter)
 - Drive Chain (see Drive Chain Slack Adjustment in the Periodic Maintenance chapter)
- Fill the engine with engine oil (see Engine Oil Change in the Periodic Maintenance chapter).
- Fill the engine with coolant and bleed the air from the cooling system (see Coolant Change in the Periodic Maintenance chapter).
- Adjust the idling (see Idle Speed Adjustment in the Periodic Maintenance chapter).

CLICK HERE TO **DOWNLOAD** THE COMPLETE MANUAL

- Thank you very much for reading the preview of the manual.
- You can download the complete manual from: www.heydownloads.com by clicking the link below



- Please note: If there is no response to CLICKING the link, please download this PDF first and then click on it.

CLICK HERE TO **DOWNLOAD** THE COMPLETE MANUAL

Crankcase

- Remove:
 - Circlip [A]
 - Collar [B]
- Special Tool - Outside Circlip Pliers: 57001-144**

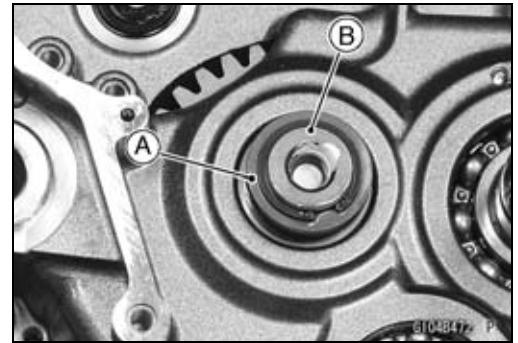

- Remove the crankcase bolts [A].

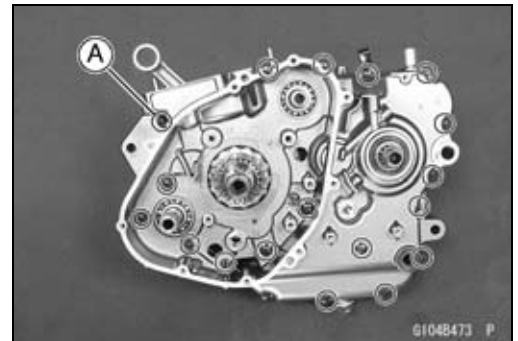

- Install the jig [A] between the crankshaft flywheels.
 - Special Tool - Crankshaft Jig: 57001-1174**
- Attach the crankcase splitting tool [B] to the left crankcase.
 - Special Tools - Bearing Puller Adapter: 57001-317**
 - Crankcase Splitting Tool Assembly: 57001-1362**
- Tighten the center bolt of the crankcase splitting tool to split the crankcase halves.
- Remove the left crankcase half.

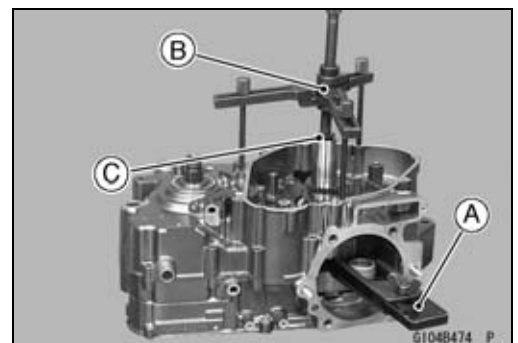

- Remove:
 - Rear Balancer Weight [A]
 - Circlip
 - Washer
 - Rear Balancer Shaft [B]
- Special Tool - Outside Circlip Pliers: 57001-144**

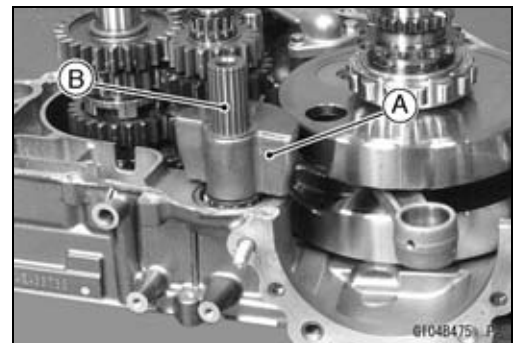

- Remove:
 - Engine Oil Feed Fitting [A]
 - Shift Rods [B] (see Transmission Shaft Removal)
 - Shift Forks [C] (see Transmission Shaft Removal)
 - Shift Drum [D] (see Transmission Shaft Removal)
 - Transmission [E] (see Transmission Shaft Removal)
- Remove the crankshaft [F] from the right crankcase half (see Crankshaft Removal).

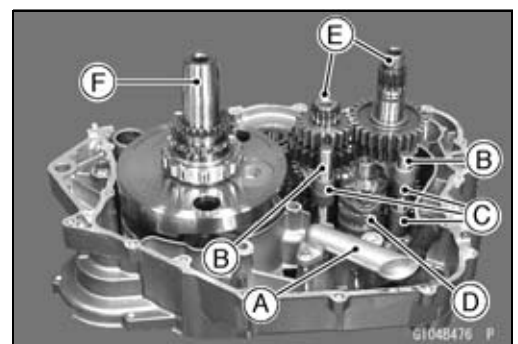

NOTICE

**Do not remove the bearings and the oil seals unless it is necessary.
Removal may damage them.**

External Shift Mechanism

Shift Pedal Removal

- Remove the shift pedal bolt [A].
- Pull out the shift pedal [B].

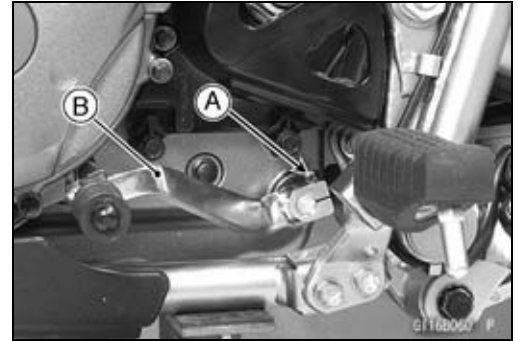

Shift Pedal Installation

- Install the shift pedal so that the top of the shift pedal pad [A] position is lower than the punch mark [B] on the alternator outer cover.

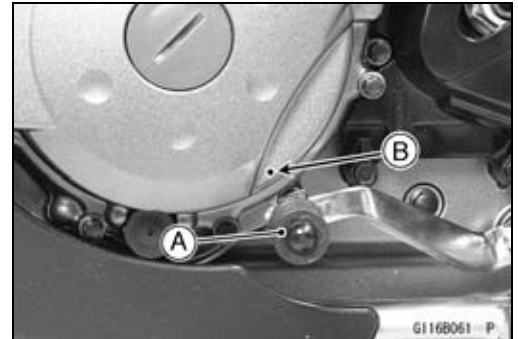

External Shift Mechanism Removal

- Remove:
 - Shift Pedal (see Shift Pedal Removal)
 - Clutch (see Clutch Removal in the Clutch chapter)
- Pull out the shift shaft [A].
- Remove:
 - Shift Drum Cam Bolt [B]
 - Shift Drum Cam [C]
 - Gear Positioning Lever Bolt [D]
 - Gear Positioning Lever [E]
 - Spring [F]

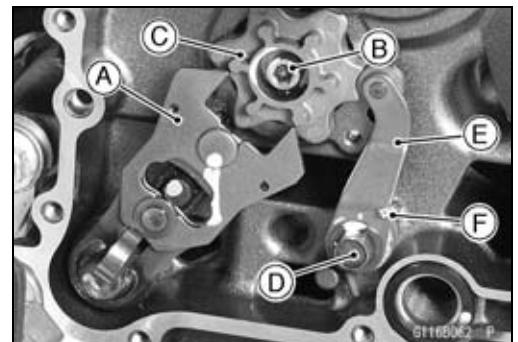

External Shift Mechanism Installation

- Install:
 - Spring [A]
 - Gear Positioning Lever [B]
- Fit each ends [C] of the spring on the original positions.
- Tighten:
 - Torque - Gear Positioning Lever Bolt [D]: 8.8 N·m (0.90 kgf·m, 78 in·lb)

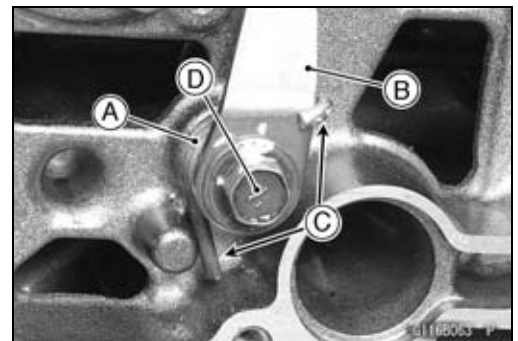

Balancer

- Replace the circlips [A] with new ones.
- Install:
 - Washer [B]
 - Circlips
- **Special Tool - Outside Circlip Pliers: 57001-144**
- Install the rear balancer chain guide [C].
- Apply a non-parmanent locking agent to the rear balancer chain guide bolts [D].
- Tighten:
 - Torque - Rear Balancer Chain Guide Bolts: 8.8 N·m (0.90 kgf·m, 78 in·lb)**
- Put the spacer [E] and idle shaft sprocket [F].
- Install the idle shaft [A].
- Hook the spring end [B] to the lever.
- While pushing the lever, hook the other spring end to the crankcase.

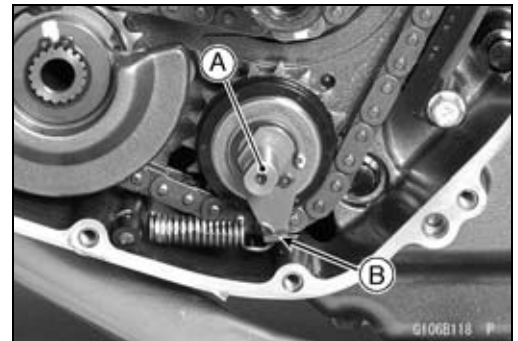
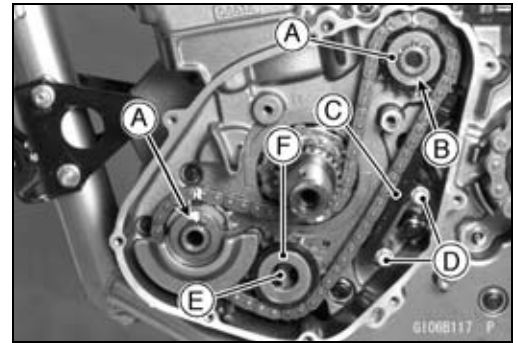

- Install the spacer [A].
- Install the front right balancer weight [B] so that the align the stepped portion [C] on the shaft and punch mark [D] on the balancer weight.

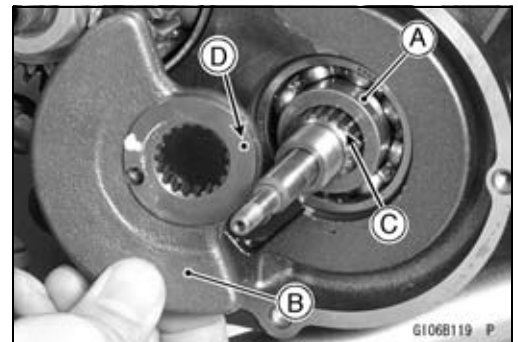

- Replace the washer [A] with a new one.
- Install the washer so that fit the claw [B] and hollow [C] on the balancer weight.

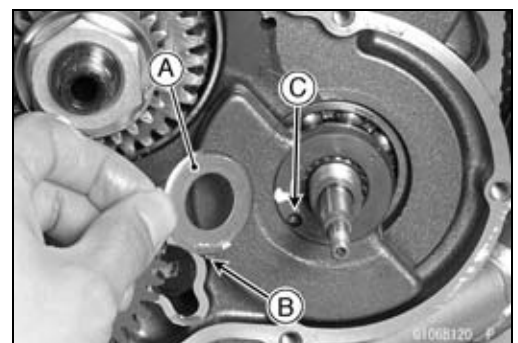

- Using the gear holder [A], tighten the front right balancer weight nut [B].
- **Special Tool - Gear Holder: 57001-1602**
- **Torque - Front Right Balancer Weight Nut: 44 N·m (4.5 kgf·m, 32 ft·lb)**
- Bend the one side of the washer [C] on the nut.

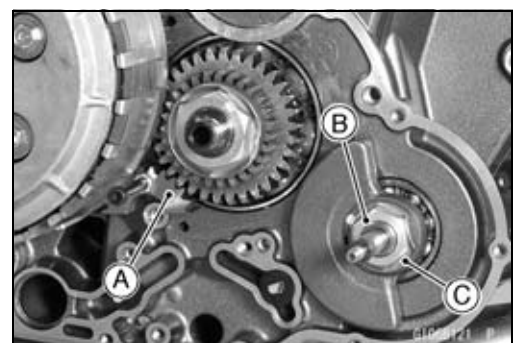

Wheels (Rims)

- Fit the collar [A] on the wheel hub [B].



- Fit the speedometer gear housing stop [A] to the fork leg projection [B].

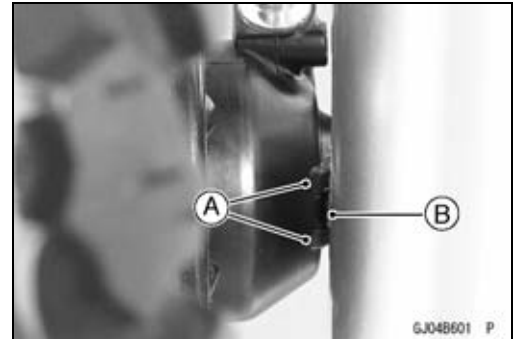

- Insert the front axle, and tighten the axle nut.
Torque - Front Axle Nut: 88 N·m (9.0 kgf·m, 65 ft·lb)
- Before tightening the axle clamp bolts on the right front fork leg, pump the front fork up and down 4 or 5 times to all on the right front fork leg to seat on the front axle.

NOTE

○Put a block in front of the front wheel to stop moving.

- Tighten the axle clamp bolts on the right fork leg first. Next, tighten the left axle clamp bolts.

Torque - Front Axle Clamp Bolts: 20 N·m (2.0 kgf·m, 15 ft·lb)

NOTE

○Tighten the two clamp bolts alternately two times to ensure even tightening torque.

- Install the speedometer cable lower end.
- Check the front brake effectiveness (see Brake Operation Inspection in the Periodic Maintenance chapter).

⚠ WARNING

After servicing, it takes several applications of the brake lever before the brake pads contact the disc, which could result in increased stopping distance and cause an accident resulting in injury or death. Do not attempt to ride the motorcycle until a firm brake lever is obtained by pumping the lever until the pads are against the disc.

Final Drive

Table of Contents

Exploded View	11-2
Specifications	11-4
Special Tools	11-5
Drive Chain	11-6
Drive Chain Slack Inspection	11-6
Drive Chain Slack Adjustment	11-6
Wheel Alignment Inspection/Adjustment	11-6
Drive Chain Wear Inspection	11-6
Drive Chain Lubrication	11-6
Drive Chain Guide Wear Inspection	11-6
Drive Chain Removal	11-6
Drive Chain Installation	11-7
Drive Chain Replacement (KL650E8 ~ EA)	11-7
Drive Chain Replacement (KL650EB ~ EC)	11-10
Sprocket, Coupling	11-14
Engine Sprocket Removal	11-14
Engine Sprocket Installation	11-14
Rear Sprocket Removal	11-15
Rear Sprocket Installation	11-15
Coupling Installation	11-15
Coupling Bearing Removal	11-16
Coupling Bearing Installation	11-16
Coupling Bearing Inspection	11-16
Coupling Bearing Lubrication	11-16
Coupling Damper Inspection	11-17
Sprocket Wear Inspection	11-17
Rear Sprocket Warp Inspection	11-17

Drive Chain

- Remove:
 - Body [A]
 - Pin Holder [B]
 - Positioning Pin [C]
 - “U” Holder [D]
 - Plate Holder [E]
 - Cutting and Riveting Pin [F]
 - Part for Riveting [G]
 - Part for Cutting [H]

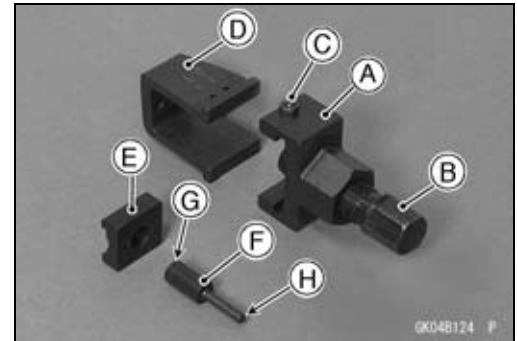

- Grind [A] the heads of the link pin to make it flat.
- Set the cutting and riveting pin [C] in the pin holder [B] as shown in the figure.

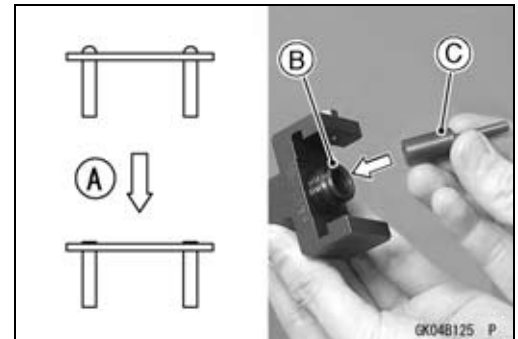

- Set the “U” holder and body, align the positioning pin [A] with the “A mark” [B].
- Tighten the pin holder by hand until the cutting and riveting pin touches the link pin.
- Be sure that the cutting and riveting pin hits center of the link pin.

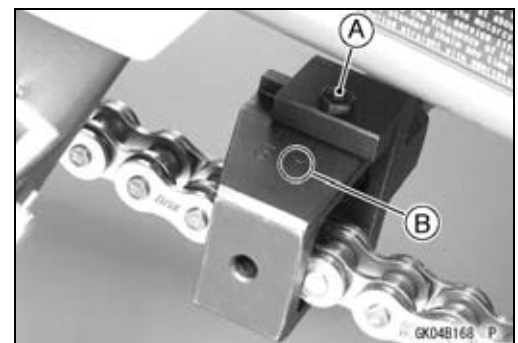

- Hold the body with a wrench [A].
- Turn the pin holder clockwise [B] with another wrench, and remove the link pin.
- Do the same procedure for removal of the other link pin.

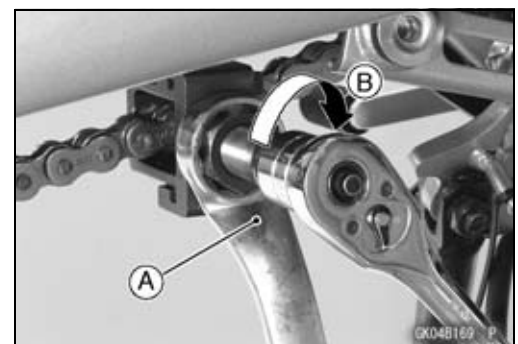

- Engage the new drive chain to the old drive chain, and change the position of the chains by pulling the old chain.
- Remove the old drive chain from the new drive chain.
- Replace the link pin [A], link plate and grease seals [B] [C] with new ones.
- Apply grease to the link pin and grease seals.
- Install the grease seals on the link pin and insert it in the ends of the drive chain.
- Install the link plate so that the mark [D] faces out.

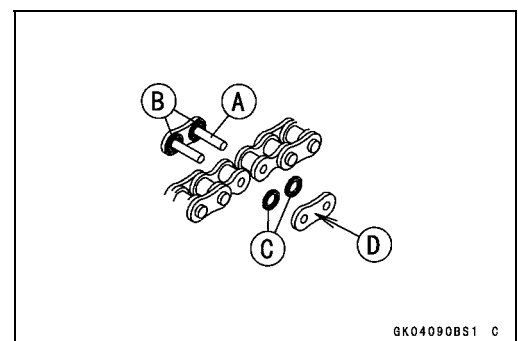

Exploded View

No.	Fastener	Torque			Remarks
		N·m	kgf·m	ft·lb	
1	Brake Lever Pivot Bolt	5.9	0.60	52 in·lb	Si
2	Front Master Cylinder Reservoir Cap Screws	1.5	0.15	13 in·lb	
3	Brake Lever Pivot Bolt Locknut	5.9	0.60	52 in·lb	
4	Brake Lever Adjusting Bolt Locknut	5.9	0.60	52 in·lb	
5	Brake Hose Banjo Bolts	25	2.5	18	
6	Front Master Cylinder Clamp Bolts	8.8	0.90	78 in·lb	S
7	Front Brake Light Switch Screw	1.2	0.12	11 in·lb	
8	Bleed Valve	7.8	0.80	69 in·lb	
9	Front Brake Pad Pins	17	1.7	12	
10	Front Caliper Holder Shaft	17	1.7	12	Si
11	Front Caliper Mounting Bolts	34	3.5	25	
12	Front Brake Disc Mounting Bolts	27	2.8	20	

B: Apply brake fluid.

S: Follow the specified tightening sequence.

Si: Apply silicone grease (ex. PBC grease).

R: Replacement Parts

Calipers

Caliper Piston and Cylinder Damage

- Visually inspect the pistons [A] and cylinder surfaces [B].
- ★ Replace the caliper if the cylinder and piston are badly scores or rusty.
 - Front Caliper [C]
 - Rear Caliper [D]

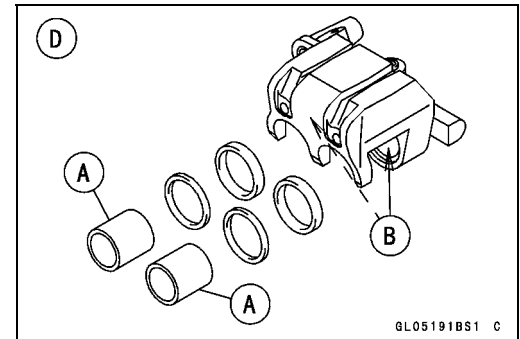
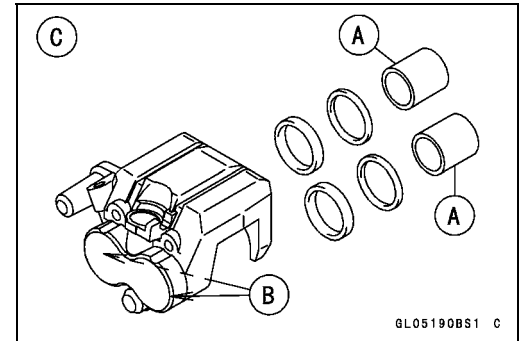

Caliper Holder Shaft Wear

The caliper body must slide smoothly on the caliper holder shafts [A]. If the body does not slide smoothly, one pad will wear more than the other, pad wear will increase, and constant drag on the disc will raise brake and brake fluid temperature.

- Check to see that the caliper holder shafts are not badly worn or stepped, and that the rubber friction boots are not damaged.
- ★ If the rubber friction boot is damaged, replace the rubber friction boot. To replace the friction boot, remove the pads and the caliper bracket.
- ★ If the caliper holder shaft is damaged, replace the caliper bracket and holder shaft.

Torque - Caliper Holder Shaft: 17 N·m (1.7 kgf·m, 12 ft·lb)

- Front Caliper [B]
- Rear Caliper [C]

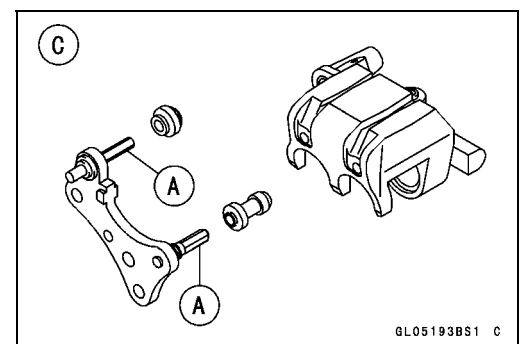
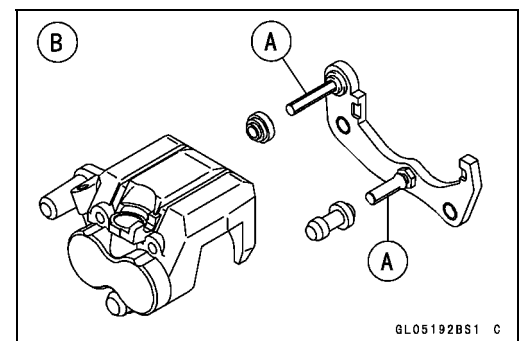

Brake Hose

Brake Hose Removal/Installation

- Refer to the Brake Hose and Pipe Replacement in the Periodic Maintenance chapter.

Brake Hose Inspection

- Refer to the Brake Hose Damage and Installation Condition Inspection in the Periodic Maintenance chapter.

Front Fork

Front Fork Oil Change

- Remove the front fork (see Front Fork Removal).
- Loosen the clamp screw [A], and remove the fork boot [B].

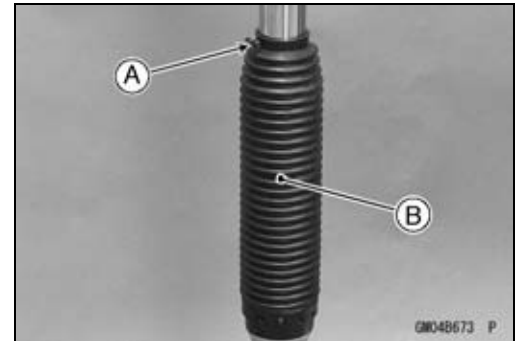

- Remove:
 - Top Plug [A] with O-ring
 - Collar [B]
 - Fork Spring Seat [C]
 - Fork Spring [D]

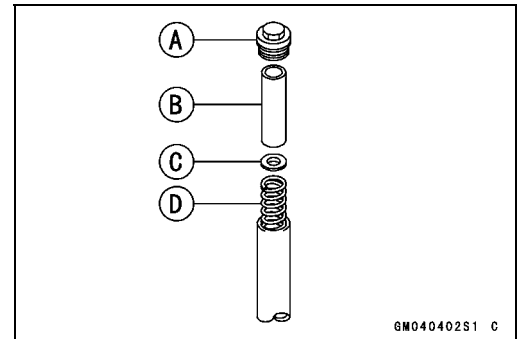

- Compress [A] the fork [B] upside down to draw out the oil into the suitable container [C].
- Pour in the specified amount of oil.

Recommended Oil

KAYABA KHL34-G10 or equivalent

Amount (Per Side):

When changing oil: Approx. 500 mL (16.9 US oz.)

After disassembly and completely dry:

585 ±4 mL (19.8 ±0.14 US oz.)

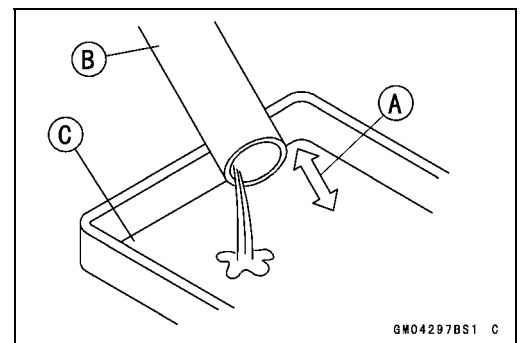

NOTE

○ Move the outer tube up and down a few times to remove the air that is trapped in the fork oil in order to stabilize the oil level.

Swingarm

Swingarm Bearing, Sleeve Inspection

NOTICE

Do not remove the bearings for inspection. Removal may damage them.

- Inspect the needle bearings [A] installed in the swingarm.
- The rollers in a bearing normally wear very little, and wear is difficult to measure. Instead of measuring, visually inspect the bearing for abrasion, discoloration, or other damage.
- ★ If the needle bearings and sleeves [B] show any signs of abnormal wear, discoloration, or damage, replace them as a set.

Swingarm Bearing Lubrication

- Refer to the Swingarm Pivot Lubrication in the Periodic Maintenance chapter.

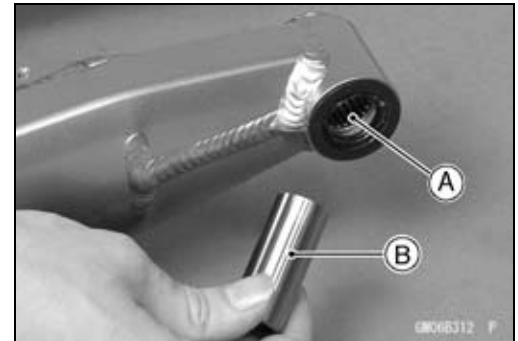

Steering

Steering Inspection

- Refer to the Steering Play Inspection in the Periodic Maintenance chapter.

Steering Adjustment

- Refer to the Steering Play Adjustment in the Periodic Maintenance chapter.

Exploded View

No.	Fastener	Torque			Remarks
		N·m	kgf·m	ft·lb	
1	Front Footpeg Bracket Bolts	25	2.5	18	
2	Rear Footpeg Bracket Bolts	25	2.5	18	
3	Sidestand Bolt and Nut	44	4.5	33	R (1)
4	Sidestand Switch Mounting Bolt	8.8	0.9	78 in·lb	L
5	Lower Rear Frame Bolts	25	2.5	18	
6	Upper Rear Frame Bolts	44	4.5	33	
7	Rear Master Cylinder Bracket Bolts	25	2.5	18	

8. KL650E8 ~ E9 Models

AD: Apply adhesive.

G: Apply grease.

L: Apply a non-permanent locking agent.

R: Replacement Parts

Fenders

Rear Fender Front Installation

- Installation is the reverse of removal.
- Insert the ledges [A] of the rear fender front into the slits [B] of the rear frame securely.

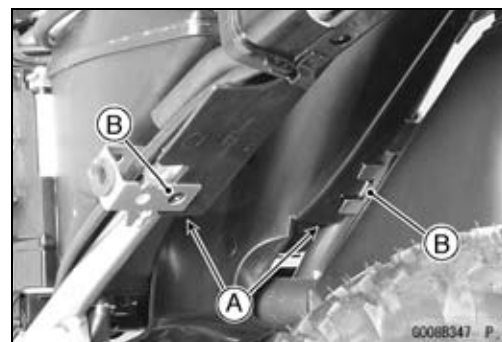

Electrical System

Table of Contents

Exploded View.....	16-3
Specifications	16-10
Special Tools and Sealant	16-11
Parts Location.....	16-12
Wiring Diagram.....	16-14
Precautions.....	16-16
Electrical Wiring.....	16-17
Wiring Inspection	16-17
Battery	16-18
Precautions.....	16-18
Battery Removal	16-18
Battery Installation	16-19
Battery Electrolyte Level Inspection.....	16-19
Battery Condition	16-19
Battery Initial Charging.....	16-20
Ordinary Charging.....	16-22
Test Charging.....	16-24
Charging System.....	16-25
Alternator Outer Cover Removal.....	16-25
Alternator Outer Cover Installation.....	16-26
Alternator Inner Cover Removal	16-26
Alternator Inner Cover Installation	16-26
Stator Coil Removal	16-27
Stator Coil Installation	16-27
Alternator Rotor Removal	16-28
Alternator Rotor Installation	16-29
Alternator Inspection	16-30
Regulator/Rectifier Inspection.....	16-32
Charging Voltage Inspection	16-34
Ignition System.....	16-36
Ignition Timing Inspection	16-36
Crankshaft Sensor Removal.....	16-37
Crankshaft Sensor Installation	16-37
Crankshaft Sensor Inspection.....	16-37
Crankshaft Sensor Peak Voltage Inspection.....	16-38
Ignition Coil Removal	16-38
Ignition Coil Installation	16-38
Ignition Coil Inspection.....	16-39
Ignition Coil Primary Peak Voltage Inspection	16-40
Spark Plug Removal	16-40
Spark Plug Installation	16-40
Spark Plug Cleaning and Inspection.....	16-40
Interlock Operation Inspection	16-40
Interlock Diode Unit Inspection	16-41
IC Igniter Removal	16-42
IC Igniter Inspection	16-42
Starter Motor Clutch	16-47
Starter Motor Clutch Removal/Installation	16-47
Starter Motor Clutch Inspection	16-47
Starter Motor Clutch Disassembly/Assembly.....	16-47

Special Tools and Sealant

**Rotor Holder, Hex 32:
57001-1184**

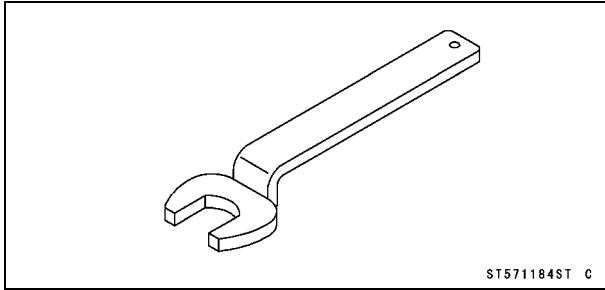

**Hand Tester:
57001-1394**

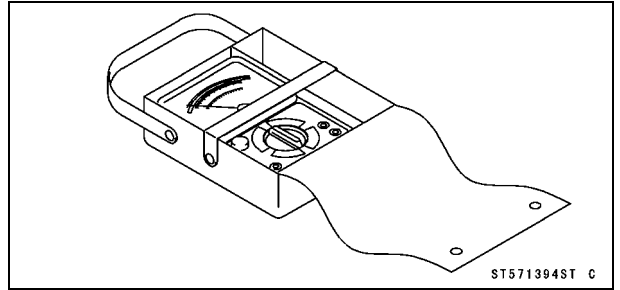

**Rotor Puller, M16/M18/M20/M22 × 1.5:
57001-1216**

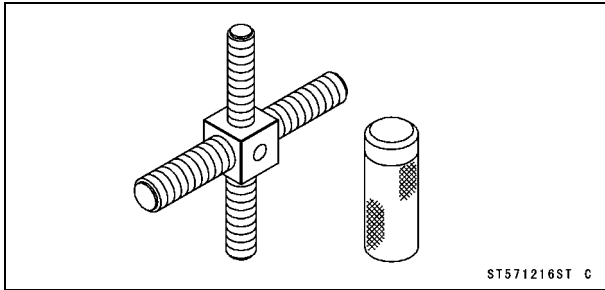

**Peak Voltage Adapter:
57001-1415**

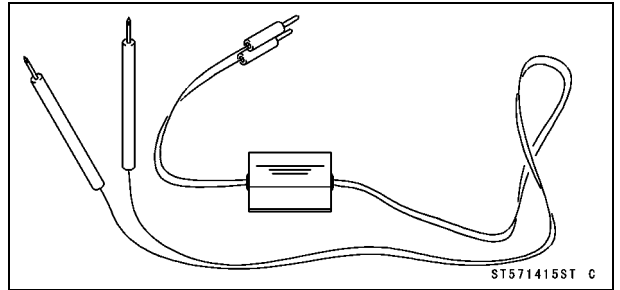

**Jack:
57001-1238**

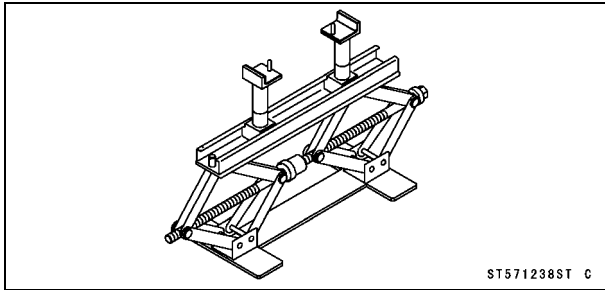

**Filler Cap Driver:
57001-1454**

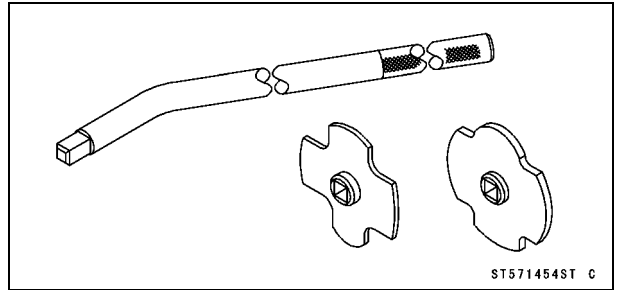

**Timing Light:
57001-1241**

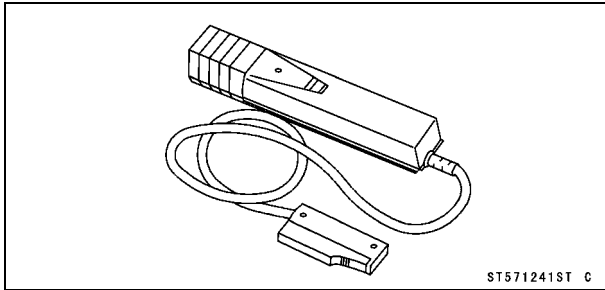

**Liquid Gasket, TB1211F:
92104-0004**

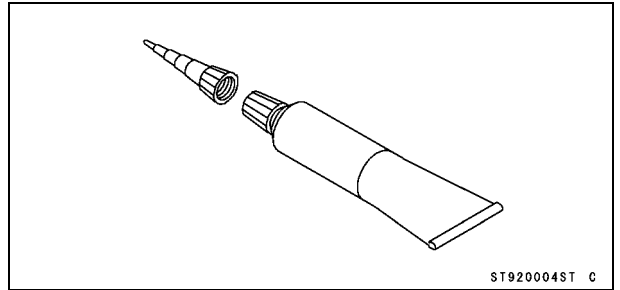

Battery

NOTE

If the electrolyte level drops, add electrolyte to the upper level line before charging.

- Leaving the caps off the cells, connect the battery to a charger, set the charging rate at 1/10 the battery capacity, and **charge it for 10 hours**. For example, if the battery is rated at 14 Ah, the charging rate would be 1.4 Ah.

NOTICE

If the battery is not given a full initial charging, it will discharge in a few weeks and will not recover fully even with supplemental charging.

DANGER

Batteries produce an explosive gas mixture of hydrogen and oxygen that can cause serious injury and burns if ignited. Keep the battery away from sparks and open flames during charging. When using a battery charger, connect the battery to the charger before turning on the charger. This procedure prevents sparks at the battery terminals which could ignite any battery gases.

NOTICE

Do not use a high rate battery charger as is typically employed at automotive service stations, unless the charging rate can be reduced to the level required. Charging the battery at a rate higher than specified may ruin the battery. Charging at a high rate causes excess heat which can warp the plates and cause internal shorting. Higher-than-normal charging rates also cause the plates to shed active material. Deposits will accumulate, and can cause internal shorting.

If the temperature of the electrolyte rises above 45°C (115°F) during charging, reduce the charging rate to lower the temperature, and increase charging time proportionately.

- Turn the charger off, then disconnect it from the battery.
- Check battery voltage. Battery voltage should be 12 ~ 13 V.
- Check the specific gravity of each cell with a hydrometer (see Battery Condition).
- ★ If the voltmeter or hydrometer readings are below those specified, additional charging is necessary before the battery can be installed.

Charging System

- To check the alternator output voltage, do the following procedures.
 - Turn the ignition switch OFF.
 - Remove the fuel tank (see Fuel Tank Removal in the Fuel System chapter).
 - Disconnect the alternator lead connector [A].
 - Connect the hand tester as shown in the table 1.
 - Install the fuel tank temporary (see Fuel Tank Installation in the Fuel System chapter).
 - Start the engine.
 - Run it at the rpm given in the table 1.
 - Note the voltage readings (total 3 measurements).



Table 1 Alternator Output Voltage

Tester Range	Connections		Reading at 4 000 rpm
	Tester (+) to	Tester (-) to	
AC 250 V	One Y lead	Another Y lead	43 V or more

- ★ If the output voltage shows the value in the table, the alternator operates properly.
- ★ If the output voltage shows a much higher than the value in the table, the regulator/rectifier is damaged. A much lower reading than that given in the table indicates that the alternator is defective.
- Check the stator coil resistance as follows.
 - Stop the engine.
 - Connect the hand tester as shown in the table 2.
 - Note the readings (total 3 measurement).

Table 2 Stator Coil Resistance

Tester Range	Connections		Reading
	Tester (+) to	Tester (-) to	
× 1 Ω	One Y lead	Another Y lead	0.1 ~ 0.8 Ω

- ★ If there is more resistance than shown in the table, or no hand tester reading (infinity) for any two leads, the stator has an open lead and must be replaced. Much less than this resistance means the stator is shorted, and must be replaced.
- Using the highest resistance range of the hand tester, measure the resistance between each of the black leads and chassis ground.
- ★ Any hand tester reading less than infinity (∞) indicates a short, necessitating stator replacement.
- ★ If the stator coils have normal resistance, but the voltage check showed the alternator to be defective; then the rotor magnets have probably weakened, and the rotor must be replaced.

Special Tool - Hand Tester: 57001-1394

Ignition System

2nd Check

- Start the engine to the following conditions.

Condition

Transmission Gear → 1st Position

Clutch Lever → Pulled in

Sidestand → Up

- Turn the ignition switch ON and push the starter button.
- Then the starter motor should turn when the starter system circuit is normality.
- ★ If the starter motor is not turn, inspect the starter lock-out switch, neutral switch, sidestand switch and interlock diode unit.
- ★ If their parts are normality replace the IC igniter.

3rd Check

- Inspect the engine for its secure stop after the following operations are completed.
- Run the engine to the following conditions.

Condition

Transmission Gear → 1st Position

Clutch Lever → Pulled in

Sidestand → Up

- Set the sidestand on the ground, then the engine will stop.
- ★ If whichever may not be stopped, inspect the neutral switch, starter lockout switch, sidestand switch and interlock diode unit.
- ★ If their parts are normality, replace the IC igniter.

Interlock Diode Unit Inspection

- Remove:
 - Upper Fairing (see Upper Fairing Removal in the Frame chapter)
 - Connector [A]
 - Interlock Diode Unit [B]

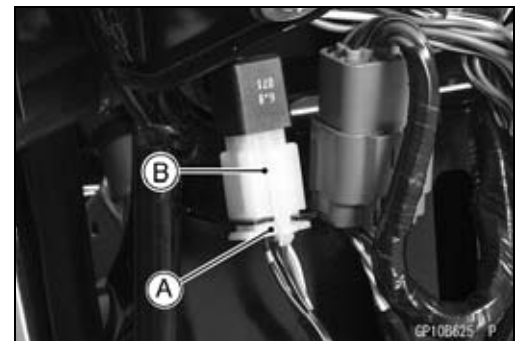

- Set the hand tester to the $\times 1\Omega$ range and connect it to the diode unit terminals to check the resistance in both directions.

Special Tool - Hand Tester: 57001-1394

- ★ The resistance should be low in one direction and more than ten times as much in the other direction. If any diode shows low or high in both directions, the diode is defective and the diode unit must be replaced.

NOTE

- The actual meter reading varies with the meter used and the individual diode, but, generally speaking, the lower reading should be from the zero to one half the scale.

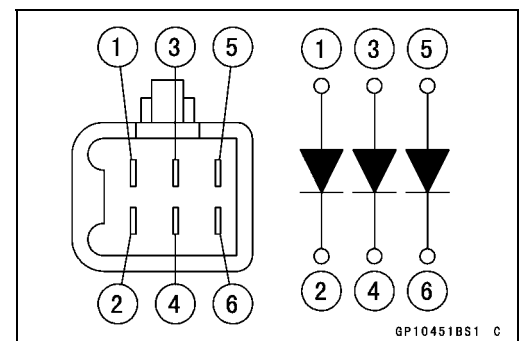

GP10451BS1 C

Electric Starter System

- Install the thrust washer(s) [A] to the right-hand end cover [B].

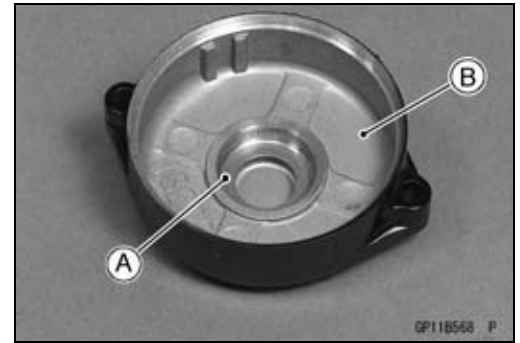

- Align the lines [A] of the yoke and end covers.
- Tighten:
 - Torque - Starter Motor Through Bolts: 4.9 N·m (0.50 kgf·m, 39 in·lb)**
- Install the starter motor (see Starter Motor Installation).



Brush Inspection

- Measure the length of each brush [A].
- ★ If any is worn down to the service limit, replace the brush plate assy and the terminal bolt assy as a set.

Starter Motor Brush Length

- Standard: 12 mm (0.47 in.)**
- Service Limit: 6.5 mm (0.26 in.)**

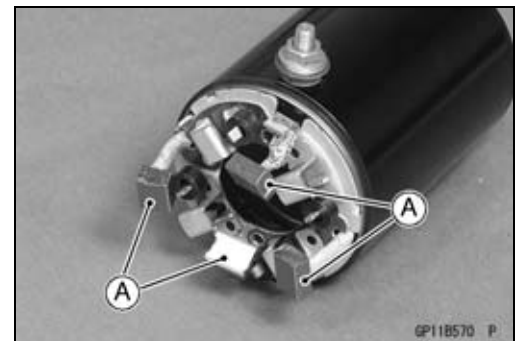

Commutator Cleaning and Inspection

- Smooth the commutator surface [A] if necessary with fine emery cloth [B], and clean out the grooves.

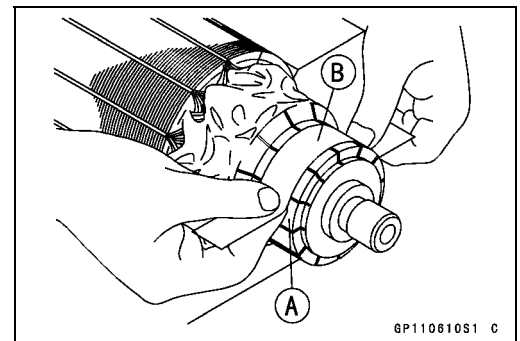

- Measure the diameter [A] of the commutator [B].
- ★ If the commutator diameter is less than the service limit, replace the starter motor with a new one .

Commutator Diameter

- Standard: 28 mm (1.10 in.)**
- Service Limit: 27 mm (1.06 in.)**

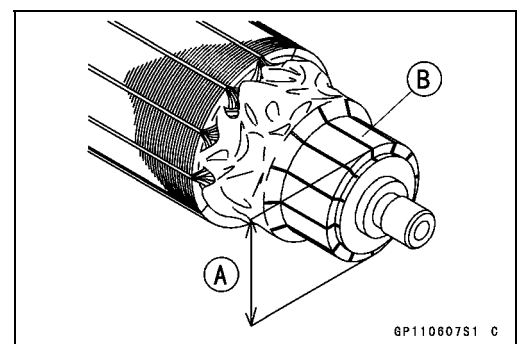

Lighting System

- Connect one 12 V battery and turn signal lights as indicated in the figure, and count how many times the lights flash for one minute.

Turn Signal Relay [A]
 Turn Signal Lights [B]
 12 V Battery [C]

- ★ If the lights do not flash as specified, replace the turn signal relay.

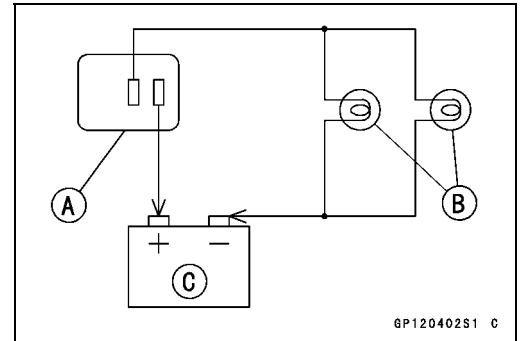

Testing Turn Signal Relay

Load		Flashing Times (c/m*)
The Number of Turn Signal Lights	Wattage (W)	
1**	21 or 23	140 ~ 250
2	42 or 46	75 ~ 95

(*): Cycle(s) per minute

(**): Corrected to "one light burned out".

Turn Signal Light Circuit

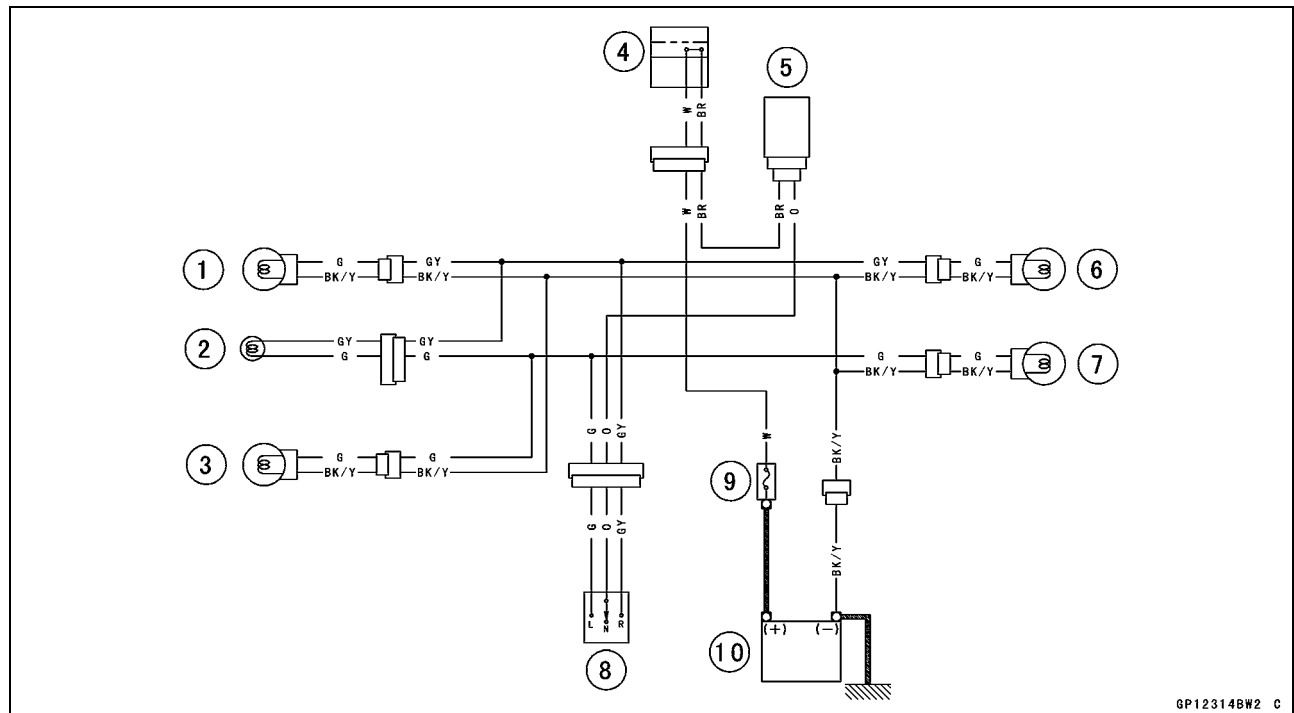

1. Front Right Turn Signal Light 12 V 21 W
2. Turn Signal Indicator Light 12 V 1.7 W
3. Front Left Turn Signal Light 12 V 21 W
4. Ignition Switch
5. Turn Signal Relay
6. Rear Right Turn Signal Light 12 V 21 W
7. Rear Left Turn Signal Light 12 V 21 W
8. Turn Signal Switch
9. Main Fuse 20 A
10. Battery 12 V 14 Ah

Appendix

Table of Contents

Cable, Wire, and Hose Routing	17-2
Troubleshooting Guide	17-34

Cable, Wire, and Hose Routing

1. Left Switch Housing Lead
2. Clamps
3. Alternator Lead Connector
4. Ignition Switch Lead
5. Right Switch Housing Lead
6. Frame Ground Lead
7. Clamps (Clamp the main harness.)
8. Main Harness
9. Run the main harness between the clamp bolt and horn nut.
10. Run the main harness so that it does not touch the horn.
11. Vacuum Switch Valve Hose (Other than AU Model)
12. Run the main harness to the right side of the vacuum switch valve hose.
13. Horn
14. Regulator/Rectifier
15. Ignition Coil
16. Install the frame ground terminal together with the upper ignition coil bolt.
17. Band
18. Crankshaft Sensor Lead Connector

Cable, Wire, and Hose Routing

1. Clamp (Clamp the coolant reserve tank overflow hose and main harness.)
2. Clamps
3. Rear Right Turn Signal Lead
4. Tail/Brake Light Lead
5. License Plate Light Lead
6. Rear Left Turn Signal Lead
7. Clamps (Clamp the rear turn signal leads as shown.)
8. Coolant Reserve Tank Overflow Hose
9. Fuse Box

CLICK HERE TO **DOWNLOAD** THE COMPLETE MANUAL

- Thank you very much for reading the preview of the manual.
- You can download the complete manual from: www.heydownloads.com by clicking the link below



- Please note: If there is no response to CLICKING the link, please download this PDF first and then click on it.

CLICK HERE TO **DOWNLOAD** THE COMPLETE MANUAL