

PART NO. WDBR50-EN-00

HITACHI

Reliable solutions

Workshop Manual

ZX 160LC-6 Hydraulic Excavator

ZX160LC-6 HYDRAULIC EXCAVATOR WORKSHOP MANUAL

WDBR50-EN-00

 **Hitachi Construction Machinery Co., Ltd.**

URL:<http://www.hitachi-c-m.com>

PRINTED IN JAPAN (K) 2016, 12

Service Manual consists of the following separate Part No.
Technical Manual (Operational Principle) : Vol. No.TODBR50-EN
Technical Manual (Troubleshooting) : Vol. No.TTDBR50-EN
Workshop Manual : Vol. No.WDBR50-EN
Engine Manual : Vol. No.EDBR50-EN

CLICK HERE TO **DOWNLOAD** THE COMPLETE MANUAL

- Thank you very much for reading the preview of the manual.
- You can download the complete manual from: www.heydownloads.com by clicking the link below



- Please note: If there is no response to CLICKING the link, please download this PDF first and then click on it.

CLICK HERE TO **DOWNLOAD** THE COMPLETE MANUAL

SECTION 5

FRONT ATTACHMENT

CONTENTS

Group 1 Front Attachment

Removal and Installation of Front Attachment.....	W5-1-1-1
---	----------

Group 2 Cylinder

Removal and Installation of Boom Cylinder.....	W5-2-1-1
Removal and Installation of Arm Cylinder.....	W5-2-2-1
Removal and Installation of Bucket Cylinder.....	W5-2-3-1
Removal and Installation of Positioning Cylinder.....	W5-2-4-1
Disassembly of Boom, Arm, and Bucket Cylinders.....	W5-2-5-1
Assembly of Boom, Arm, and Bucket Cylinders.....	W5-2-5-8
Disassembly of Positioning Cylinder.....	W5-2-6-1
Assembly of Positioning Cylinder.....	W5-2-6-6

Group 3 Hose Rupture Valve

Removal and Installation of Hose Rupture Valve for Boom Cylinder.....	W5-3-1-1
Removal and Installation of Hose Rupture Valve for Arm Cylinder.....	W5-3-2-1
Removal and Installation of Hose Rupture Valve for Positioning Cylinder.....	W5-3-3-1
Structure of Hose Rupture Valve for Boom Cylinder (Right).....	W5-3-4-1
Structure of Hose Rupture Valve for Boom Cylinder (Left).....	W5-3-4-3
Structure of Hose Rupture Valve for Arm Cylinder.....	W5-3-4-5
Structure of Hose Rupture Valve for Positioning Cylinder.....	W5-3-4-7

SAFETY

General Precautions for the Cab

- Before entering the cab, thoroughly remove all dirt and/or oil such as mud, grease, soil or stones from the soles of your work boots. If any controls such as a pedal is operated while with dirt and/or oil on the soles of the operator's work boots, the operator's foot may slip off the pedal, possibly resulting in a personal accident.
- Do not mess up around the operator's seat with parts, tools, soil, stones, obstacles that may fold up or turn over, cans or lunch box. The levers or pedals become inoperable if obstacle jams in operation stroke of the travel levers/pedals, pilot control shut-off lever or control levers, which may result in serious injury or death.
- Avoid storing transparent bottles in the cab. Do not attach any transparent type window decorations on the windowpanes as they may focus sunlight, possibly starting a fire.
- Refrain from listening to the radio, or using music headphones or mobile telephones in the cab while operating the machine.
- Keep all flammable materials and/or explosives away from the machine.
- After using the ashtray, always cover it to extinguish the match and/or tobacco.
- Do not leave cigarette lighters in the cab. When the temperature in the cab increases, the lighter may explode.
- Correctly lay the floor mat specific to the machine. If another floor mat is used, it may be displaced and contact with the travel pedals during operation, resulting in serious injury or death.

SAFETY

- Avoid swinging the upperstructure on slopes. Never attempt to swing the upperstructure downhill. The machine may tip over. If swinging uphill is unavoidable, carefully operate the upperstructure and boom at slow speed.
- If the engine stalls on a slope, immediately lower the bucket to the ground. Return the control levers to neutral. Then, restart the engine.
- Be sure to thoroughly warm up the machine before ascending steep slopes. If hydraulic oil has not warmed up sufficiently, sufficient performance may not be obtained.
- Use a signal person when moving, swinging or operating the machine in congested areas. Coordinate hand signals before starting the machine.
- Before moving machine, determine which way to move travel pedals/levers for the direction you want to go. When the travel motors are in the rear, pushing down on the front of the travel pedals or pushing the levers forward moves the machine forward, towards the idlers. An arrow-mark seal is stuck on the inside surface of the side frame to indicate the machine front direction.
- Select a travel route that is as flat as possible. Steer the machine as straight as possible, making small gradual changes in direction.
- Before traveling on them, check the strengths of bridges and road shoulders, and reinforce if necessary.
- Use wood plates in order not to damage the road surface. Be careful of steering when operating on asphalt roads in summer.
- When crossing train tracks, use wood plates in order not to damage them.
- Do not make contact with electric wires or bridges.
- When crossing a river, measure the depth of the river using the bucket, and cross slowly. Do not cross the river when the depth of the river is deeper than the upper edge of the upper roller.
- When traveling on rough terrain, reduce engine speed. Select slow travel speed. Slower speed will reduce possible damage to the machine.
- Avoid operations that may damage the track and undercarriage components.
- During freezing weather, always clean snow and ice from track shoes before loading and unloading the machine, to prevent the machine from slipping.



M104-05-008

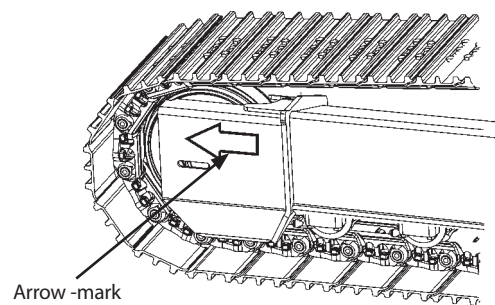

M178-03-001



SA-011

SAFETY

Practice Safe Maintenance

To avoid accidents:

- Understand service procedures before starting work.
- Keep the work area clean and dry.
- Do not spray water or steam inside cab.
- Never lubricate or service the machine while it is moving.
- Keep hands, feet and clothing away from power-driven parts.

Before servicing the machine:

1. Park the machine on a level surface.
2. Lower the bucket to the ground.
3. Turn the auto-idle switch off.
4. Run the engine at slow idle speed without load for 5 minutes.
5. Turn the key switch to OFF to stop engine.
6. Relieve the pressure in the hydraulic system by moving the control levers several times.
7. Remove the key from the key switch.
8. Attach a "Do Not Operate" tag on the control lever.
9. Pull the pilot control shut-off lever to the LOCK position.
10. Allow the engine to cool.

- If a maintenance procedure must be performed with the engine running, do not leave the machine unattended.
- If the machine must be raised, maintain a 90 to 110° angle between the boom and arm. Securely support any machine elements that must be raised for service work.
- Inspect certain parts periodically and repair or replace as necessary. Refer to the section discussing that part in the "MAINTENANCE" chapter in the operator's manual.
- Keep all parts in good condition and properly installed.
- Fix damage immediately. Replace worn or broken parts. Remove any buildup of grease, oil, or debris.
- When cleaning parts, always use nonflammable detergent oil. Never use highly flammable oil such as fuel oil and gasoline to clean parts or surfaces.
- Turn the battery disconnect switch to OFF before adjusting the electrical systems or performing welding on the machine.



SA-028



SA-527

SAFETY

Remove Paint Before Welding or Heating

- Hazardous fumes can be generated when paint is heated by welding, soldering, or using a torch. If inhaled, these fumes may cause sickness.
 - Avoid potentially toxic fumes and dust.
 - Do all such work outside or in a well-ventilated area. Dispose of paint and solvent properly.
 - Remove paint before welding or heating:
 1. If you sand or grind paint, avoid breathing the dust. Wear an approved respirator.
 2. If you use solvent or paint stripper, remove stripper with soap and water before welding. Remove solvent or paint stripper containers and other flammable materials from area. Allow fumes to disperse at least 15 minutes before welding or heating.



SA-029

Beware of Asbestos and Silica Dust and Other Contamination

- Take care not to inhale dust produced in the work site. Inhalation of asbestos fibers may be the cause of lung cancer. Inhalation of silica dust or other contaminations may cause sickness.
 - Depending on the work site conditions, the risk of inhaling asbestos fiber, silica dust or other contaminations may exist. Spray water to prevent asbestos fibers, silica dust or other contaminations from becoming airborne. Do not use compressed air.
 - When operating the machine in a work site where asbestos fibers, silica dust or other contaminations might be present, be sure to operate the machine upwind, and wear a mask rated to prevent the inhalation of asbestos, silica dust or other contaminations.
 - Keep bystanders out of the work site during operation.
 - Asbestos fibers might be present in imitation parts. Use only genuine Hitachi Parts.



SA-029

SECTION AND GROUP CONTENTS

WORKSHOP MANUAL

SECTION 4 UNDERCARRIAGE

Group 1 Swing Bearing	
Group 2 Travel Device	
Group 3 Center Joint	
Group 4 Track Adjuster	
Group 5 Missing Number	
Group 6 Upper and Lower Roller	
Group 7 Track	

SECTION 5 ATTACHMENT

Group 1 Front Attachment	
Group 2 Cylinder	
Group 3 Hose Rupture Valve	

All information, illustrations and specifications in this manual are based on the latest product information available at the time of publication. The right is reserved to make changes at any time without notice.

SECTION 1 GENERAL

Group 2 Tightening

Tightening Bolts and Nuts

CAUTION: Use tools appropriate for the work to be done. Makeshift tools and procedures can create safety hazards. For loosening and tightening nuts and bolts, use correct size tools. Otherwise, tightening tools may slip, potentially causing personal injury.



WDAA-01-02-001







Bolt Types

Tighten the nuts or bolts correctly to the torque specifications.

As the different types and grades of bolt are used, use and tighten the correct bolts correctly when assembling the machine or components.

Specified Tightening Torque Chart

2013/09

Bolt Dia. mm	Hexagon Head Bolt						Socket Bolt			
	   WDAA-01-02-002		   WDAA-01-02-003		 WDAA-01-02-004		Wrench Size mm	Socket Bolt		Wrench Size mm
	N-m	(lbf-ft)	N-m	(lbf-ft)	N-m	(lbf-ft)		N-m	(lbf-ft)	
6					3 to 4	(2.2 to 3)	10			5
8	30	(22)	20	(15)	10	(7.4)	13	20	(15)	6
10	65	(48)	50	(37)	20	(15)	17	50	(37)	8
12	110	(81)	90	(66)	35	(26)	19	90	(66)	10
14	180	(133)	140	(103)	55	(41)	22	140	(103)	12
16	270	(200)	210	(155)	80	(59)	24	210	(155)	14
18	400	(300)	300	(220)	120	(89)	27	300	(220)	14
20	550	(410)	400	(300)	170	(125)	30	400	(300)	17
22	750	(550)	550	(410)	220	(162)	32			
24	950	(700)	700	(520)	280	(205)	36			
27	1400	(1030)	1050	(770)	400	(300)	41			
30	1950	(1440)	1450	(1070)	550	(410)	46			
33	2600	(1920)	1950	(1440)	750	(550)	50			
36	3200	(2360)	2450	(1810)	950	(700)	55			

SECTION 1 GENERAL

Group 3 Painting

Painting

Painting specification

Surfaces to Be Painted	Painting Color
Main surface of upperstructure (except cab)	YR1-01 [TAXI yellow]
Main frame	P1-01 [High Grade Black]
Inner	N-40 [N4 Gray]
Engine cover	P1-01 [High Grade Black]
Handrail	P1-01 [High Grade Black]
Front	YR1-01 [TAXI yellow]
Track (including swing bearing)	N-10 [Black]
Floor plate	N-40 [N4 Gray]

Final painted color

Inside and outside surface of cab	P1-01 [High Grade Black] Y1-03 [Shining Silver]
Right window beam	Charcoal Black
Seat stand	Black (N2.0)
Lever (Travel, pilot shut-off)	Warm Gray (N2.5)
Rear Camera	P1-01 [High Grade Black]
Exhaust pipe	Black Heat-Resistant Coating
Tool box, Tool box cover	P1-01 [High Grade Black]
Decoration cover, Step	P1-01 [High Grade Black]
Handrail on upperstructure right side	P1-01 [High Grade Black]
Mirror stay	P1-01 [High Grade Black]
Nonslip plate	Kansai Paint Co., Ltd. 1400 (Deep Black)
DEF tank bracket	Black Cation Electric Deposited Coating
Muffler bracket	Black Cation Electric Deposited Coating
Center cover mounting support	P1-01 [High Grade Black]
Handrail (CAB)	P1-01 [High Grade Black]

SECTION 1 GENERAL

Group 5 Preparation

Hydraulic Circuit Pressure Release Procedure

Release any remaining pressure as follows before removing/installing the front attachment.

1. Set pilot shut-off lever (1) to the UNLOCK position.
2. Turn engine stop switch (2) ON.

 **NOTE:** Perform step 1 and step 2, and set the key switch to the START position. Although the starter rotates, the engine does not start.

IMPORTANT: Battery will deplete. Operate the key switch for short period.

3. With the key switch set in the START position, operate the control lever in order to release any pressure in the hydraulic circuit 4 to 5 times.
4. Return pilot shut-off lever (1) to the LOCK position.
5. Turn engine stop switch (2) OFF.

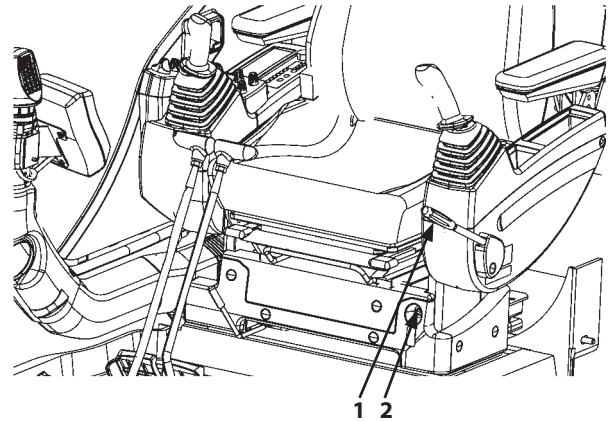

M1U1-01-029

SECTION 2 MAINTENANCE STANDARD

Group 1 Upperstructure

5. Clearance between plunger (5) and connecting rod (b)

Unit: mm

Standard	Allowable Limit
0.15	0.4

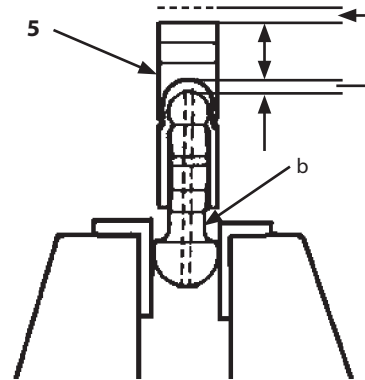

b- Connecting Rod

W178-02-11-107

6. Clearance between inner diameter (D) of servo small chamber and outer diameter (a) of servo piston (9)

Unit: mm

	Standard	Allowable Limit
D-a	0.083	0.2

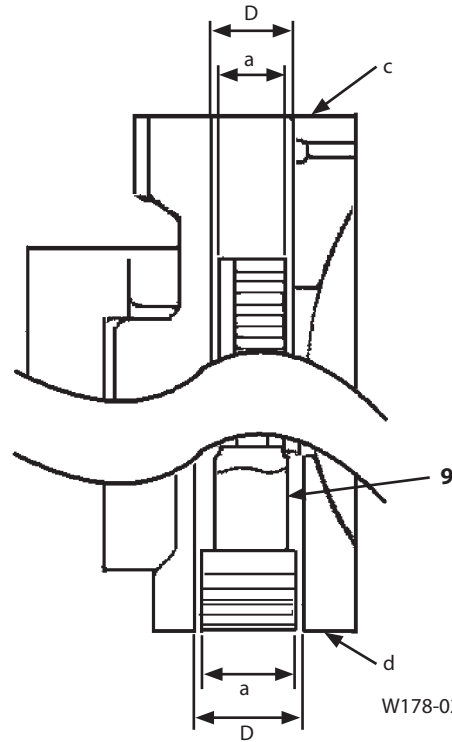

c- Small Diameter Side

d- Large Diameter Side

W178-02-11-108

7. Clearance between inner diameter (D) of servo large chamber and outer diameter (a) of servo piston (9)

Unit: mm

	Standard	Allowable Limit
D-a	0.079	0.2

8. Clearance between inner diameter (D) of valve plate (7) and outer diameter (a) of pin (8)

Unit: mm

	Standard	Allowable Limit
D-a	0.051	0.3

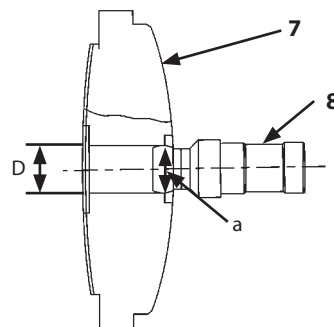

WD CD-02-01-003

SECTION 2 MAINTENANCE STANDARD

Group 2 Undercarriage

Front Idler

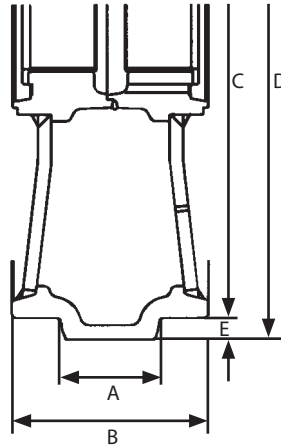

W166-03-05-001

Unit: mm

	Standard	Allowable Limit	Remedy
A	84	[79]	Build up welding and hand finishing or replace
B	159	-	
C	500	[495]	
D	538	-	
E	19	21.5	

Axle and Bushing

Unit: mm (in)

		Standard	Allowable Limit	Remedy
Axle	Outer Diameter	75.0	[74.2]	Replace
Bushing	Inner Diameter	75.0	[75.8]	
	Flange Thickness	2.0	[1.6]	

NOTE: Values in [] are just for reference.

SECTION 2 MAINTENANCE STANDARD

Group 3 Front Attachment

Side Cutter (2015428, 2015429)

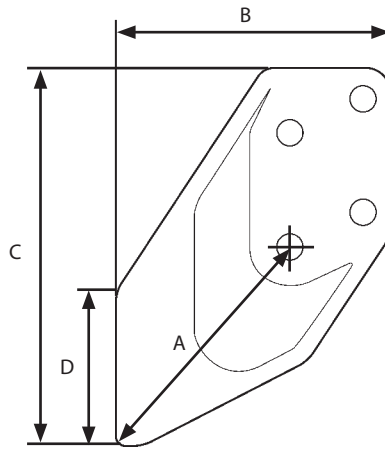

W1T1-04-01-004

Unit: mm

	Standard	Allowable Limit	Remedy
A	229	149	Replace
B	245	-	
C	330	-	
D	135	-	

SECTION 3 UPPERSTRUCTURE

Group 1 Cab

Removal and Installation of Cab

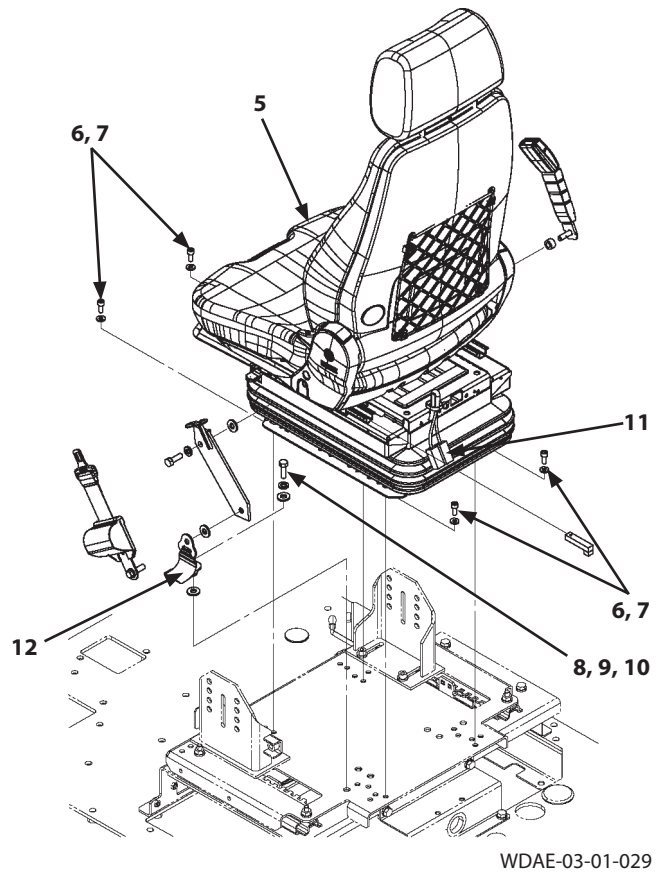
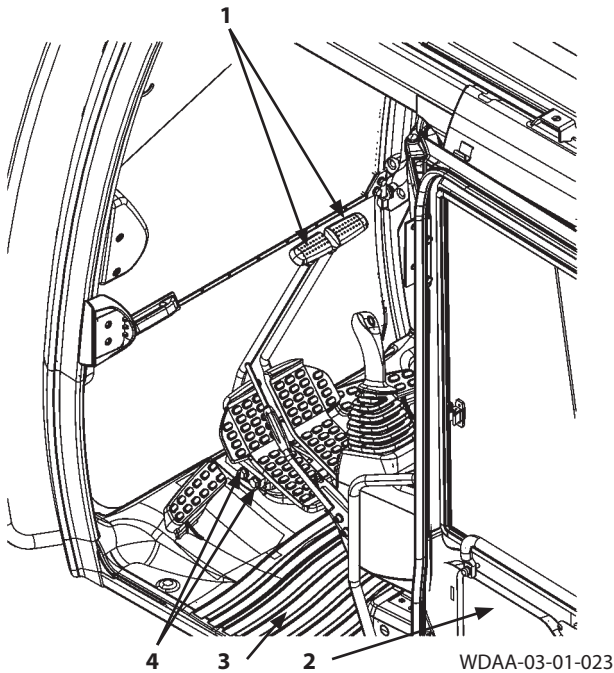

IMPORTANT: Cap the open ends in case the hoses and pipes have been disconnected. In addition, attach identification tags onto the connectors, hoses, and pipes for assembling. If the clips which secure the hoses have been removed, install the clips after connecting the hoses.

Removal

1. Set the machine position for inspection and maintenance. (Refer to W1-5-1.)
2. Open door (2).
3. Disconnect connectors (11) (2 used).

4. Remove bolt (8), spring washer (9), washers (10) (2 used), and belt (12).

 : 5/8 in

CAUTION: Seat (5) weight: 45 kg

5. Remove socket bolts (6) (4 used) and washers (7) (4 used). Remove seat (5).

 : 6 mm

6. Remove floor mat (3).

7. Remove bolts, washers (4) (4 used). Remove travel control levers (1) (2 used).

 : 17 mm

SECTION 3 UPPERSTRUCTURE

Group 1 Cab

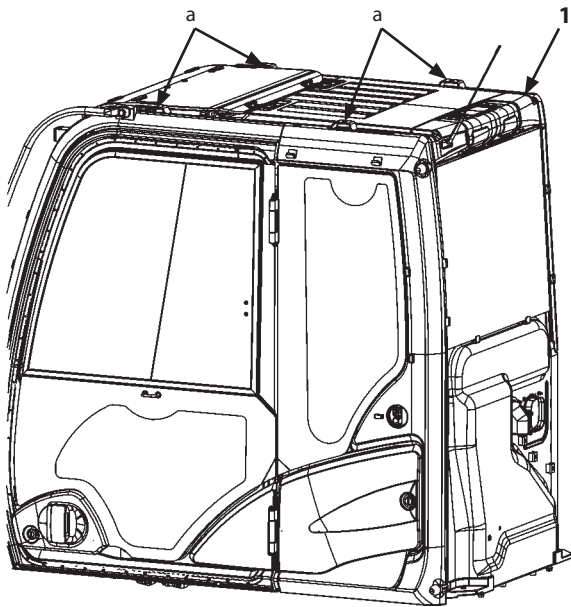

a - Lifting Bracket

WDAA-03-01-058

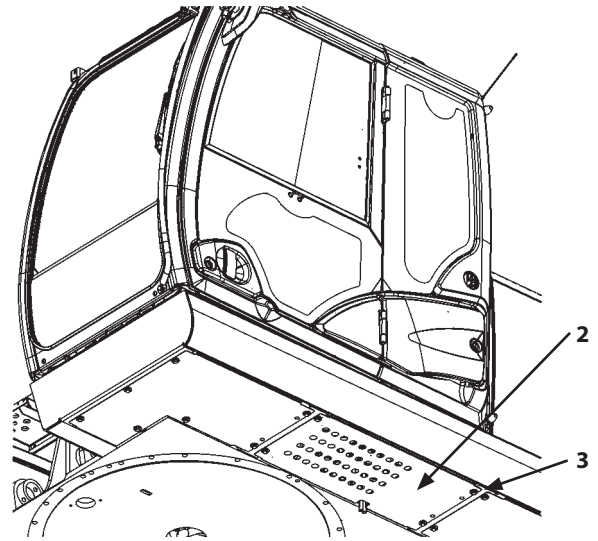

WDBE-03-12-005

⚠ CAUTION: The cab (1) assembly weight: 380 kg

45. Attach nylon slings onto lifting brackets (a) (4 places) of cab (1). Hoist and hold the cab (1) assembly.

⚠ CAUTION: Remove cover (2) while holding it. Do not drop cover (2).

46. Remove bolts, washers (3) (4 used). Remove cover (2).

 : 17 mm

SECTION 3 UPPERSTRUCTURE

Group 1 Cab

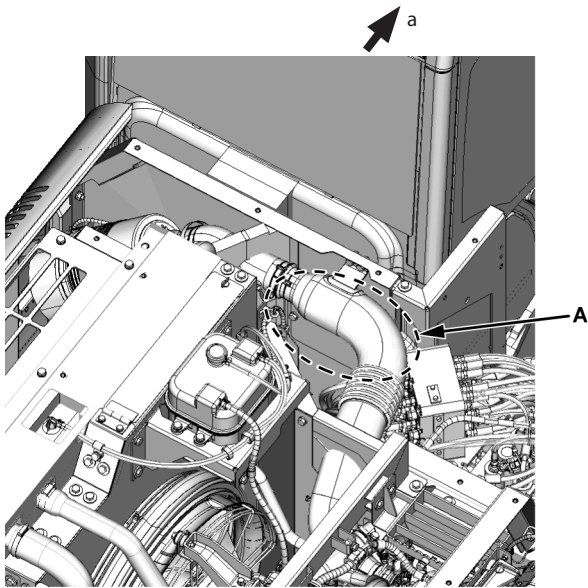

a- Machine Front Side

WDBR-03-01-002

Detail A

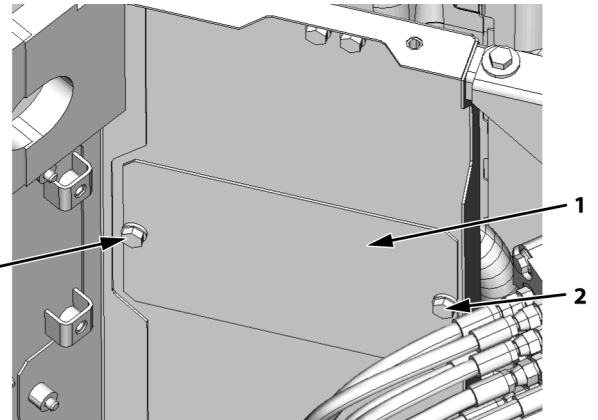

WDBR-03-01-003

IMPORTANT: Do not use the impact wrench when tightening bolt (4). The cover may be damaged.

21. Connect connector (3) with bolt (4).

 : 12 mm

 : 9.8 N·m

IMPORTANT: Check that the parts on the cab side are surely seen from the (C) part of connector (3).

22. Connect connector (9). Shift lever (10). Lock the lock.
23. Install clip (8) and bracket (7) with bolts, washers (5) (2 used).

 : 17 mm

 : 50 N·m

24. Install cover (1) with bolts (2) (2 used).

 : 17 mm

 : 50 N·m

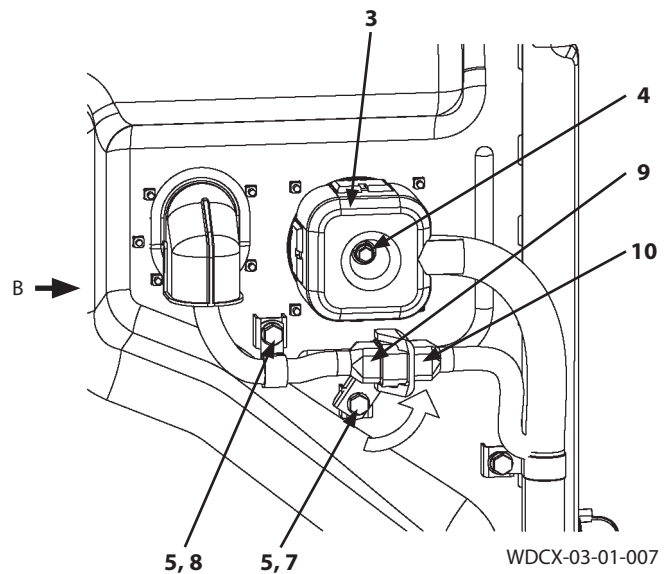

WDCX-03-01-007

View B

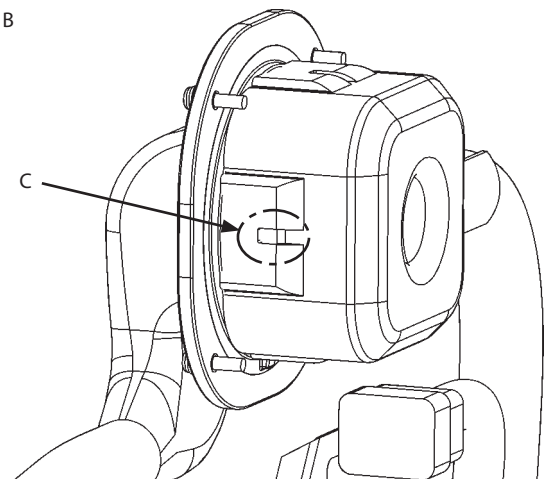

WDDK-03-01-005

SECTION 3 UPPERSTRUCTURE

Group 1 Cab

Dimensions of Cab Glass

CAUTION: Use the genuine parts for the glasses

Unit: mm

Section A

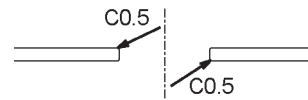
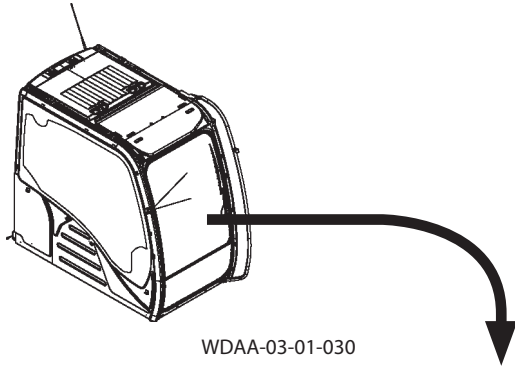

WDAA-03-01-036

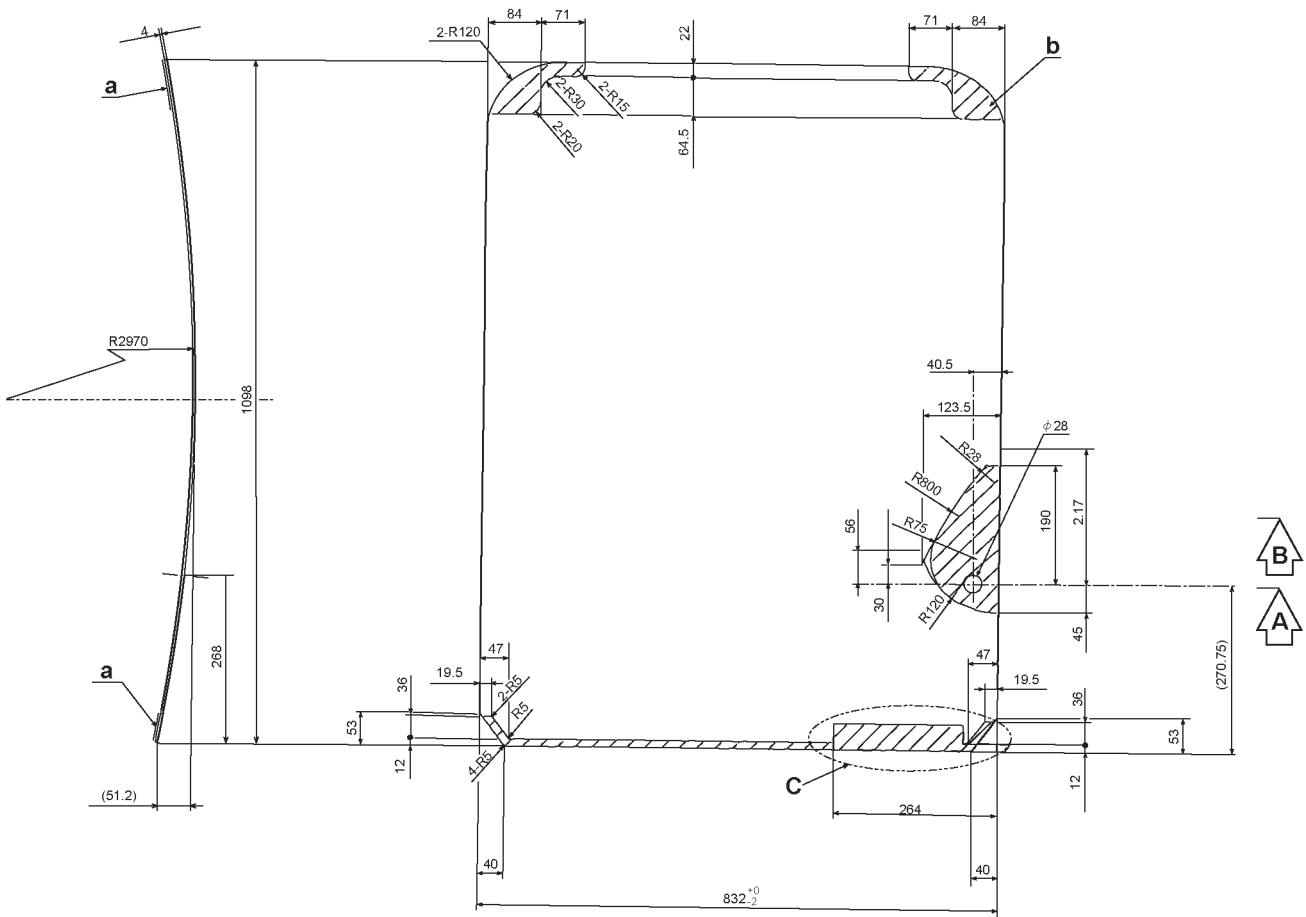

a - Black Ceramic Painted Surface

b - Black Ceramic Painted Range

WDAA-03-01-001

Section B

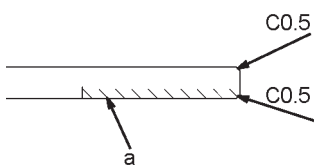

a - Black Ceramic Painted Surface

WDAA-03-01-035

Detail C

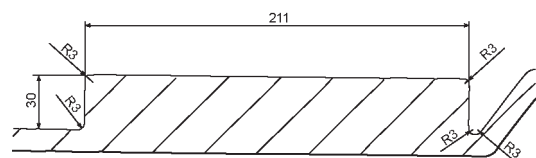

WDAA-03-01-002

SECTION 3 UPPERSTRUCTURE

Group 1 Cab

Procedure to Install Cab Glass

Procedures to Install Right-Hand Glass (1), Rear Left-Hand Glass (2), Lower Door Glass (3), and Rear Glass (4)

1. Cut off the residual adhesive from the cab (7) side by 1 to 2 mm deep all around by using a knife or similar.

 **NOTE:** Do not damage the cab (7) paint.

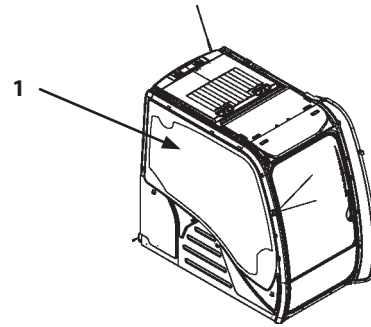

WDAA-03-01-030

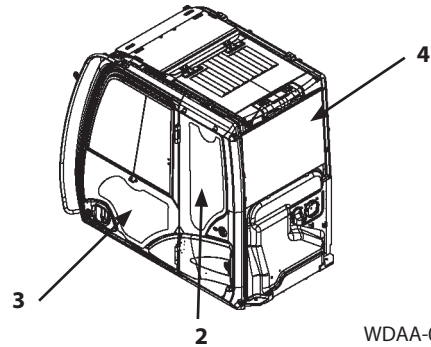

WDAA-03-01-031

2. Clean the cutting edge of adhesive at cab (7) side by using white spirit.

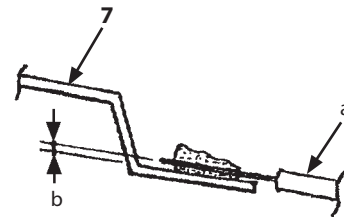

W1SE-02-01-036

IMPORTANT: Primer should be shaken for about 1 minute and mix thoroughly before opening the cap. After opening Primer, apply Primer as quickly as possible and close the cap immediately after using. After opening Primer, all the contents should be used within 180 days (or 2 hours with the cap off).

3. Apply Primer for paint (Sika Aktivator DM-1) to the cutting edge of adhesive at cab (7) side by using a brush. Wait for about 15 minutes in order to let it dry by itself.

a - Knife

b - Cut off adhesive by 1 to 2 mm deep.

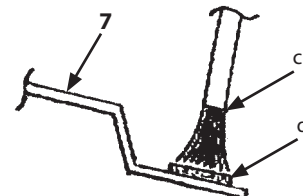

W1SE-02-01-038

c - Apply Primer by using a brush.

d - Cutting edge of adhesive at cab (7) side

SECTION 3 UPPERSTRUCTURE

Group 2 Counterweight

Removal and Installation of Counterweight

Detail A

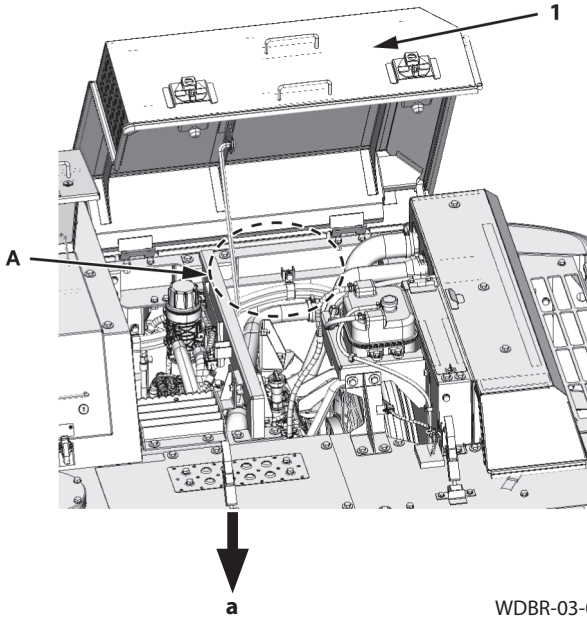

a - Machine Front Side

WDBR-03-02-001

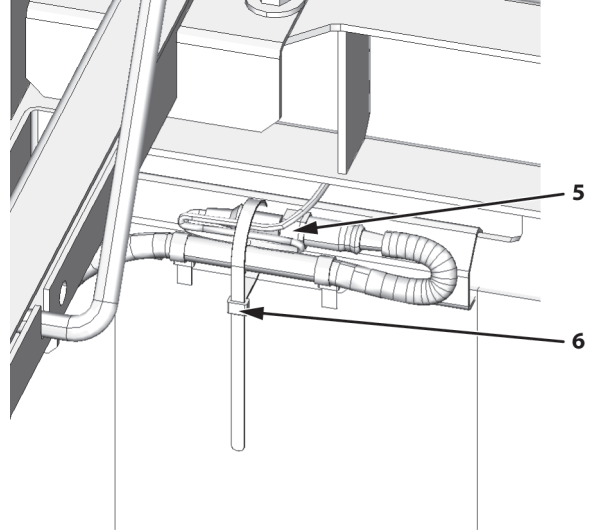

WDBR-03-02-002

Removal

1. Set the machine position for inspection and maintenance. (Refer to W1-5-1.)
2. Open engine cover (1).
3. Remove clip band (6). Disconnect connector (5).

 : 17 mm

4. Close engine cover (1).

SECTION 3 UPPERSTRUCTURE

Group 3 Main Frame

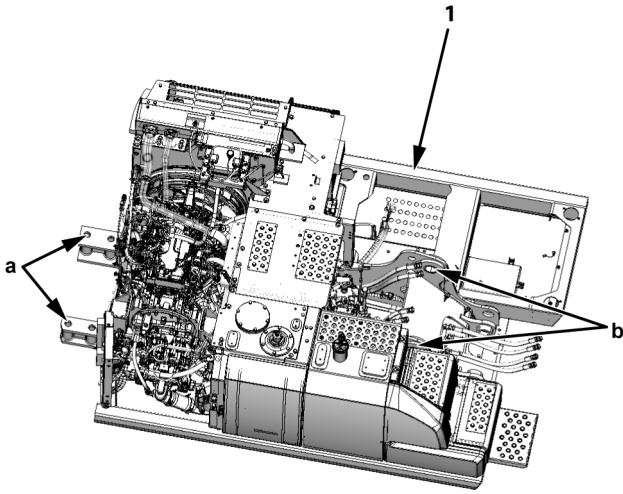

WDBR-03-03-012

- a- Counterweight Mounting Part b- Boom Mounting Bracket Hole

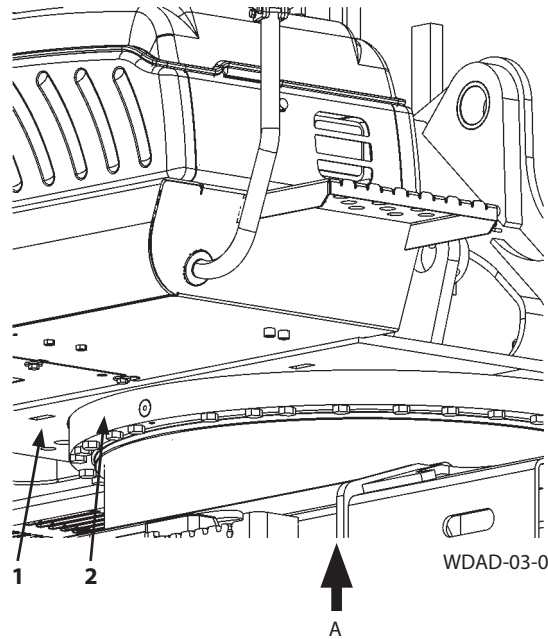

WDAD-03-03-001

⚠ CAUTION: Main frame (1) weight: 3950 kg

26. Attach wire ropes onto the rear side (counterweight mounting parts (a) (2 places)) of main frame (1) and boom mounting bracket holes (b) (2 places).
27. Reduce slack of the wire ropes by using chain blocks. Put the matching marks on main frame (1) and outer race (2) of the swing bearing.
28. Remove bolts (3) (2 used) and bolts (4) (33 used).

: 30 mm

NOTE: *THREBOND #1102 or equivalent has been applied to bolt (3).*

29. Adjust the center of gravity of main frame (1) by using chain blocks. Hoist and remove main frame (1) from outer race (2) of the swing bearing.

NOTE: *THREBOND #1102 or equivalent has been applied on the mating surface.*

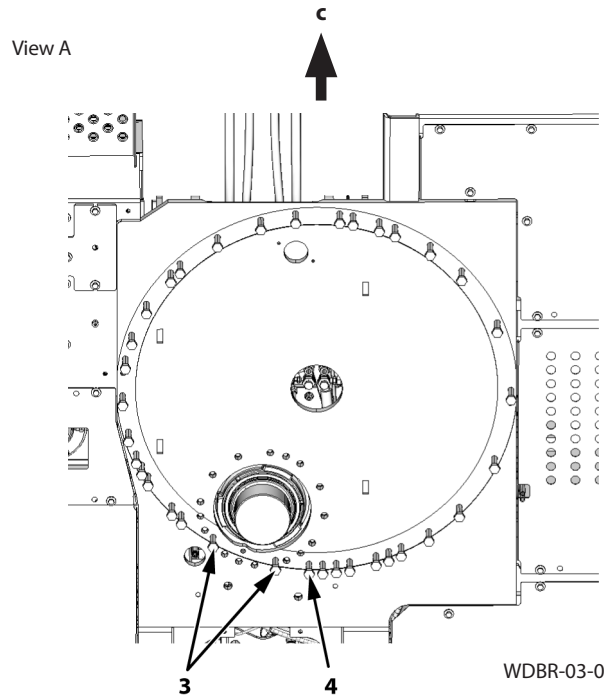

WDBR-03-03-013

c- Machine Front Side

SECTION 3 UPPERSTRUCTURE

Group 4 Engine

Removal and Installation of Engine

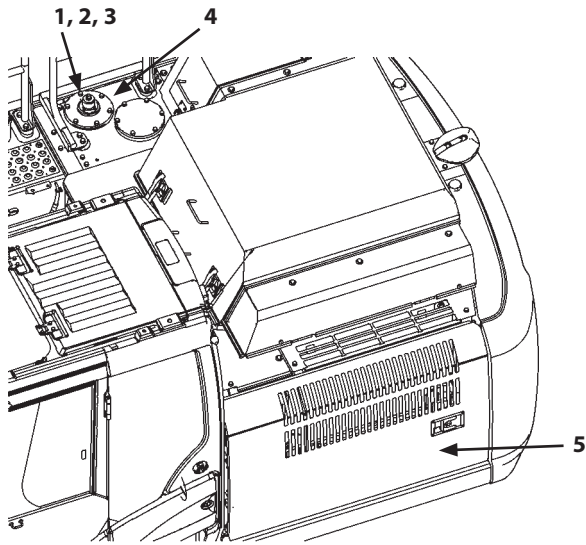

WDBR-03-04-001

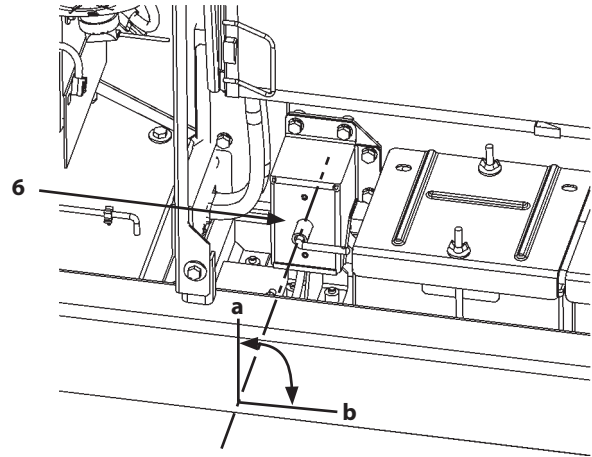

a- OFF Position
b- ON Position

WDBR-03-04-002

CAUTION: Escaping fluid under pressure may penetrate the skin and eyes, and cause serious injury. Release the pressure before disconnecting the hydraulic pipings or removing other equipment. Hot hydraulic oil just after operation may spout out and cause severe burns. Allow oil to cool before starting any work.

IMPORTANT: The hoses and pipes contain hydraulic oil. When removing the hoses and pipes, receive oil with a container in order to avoid spilling oil.

IMPORTANT: Cap the open ends in case the hoses and pipes have been disconnected. In addition, attach identification tags onto the connectors, hoses, and pipes for assembling. If the clips which secure the hoses have been removed, install the clips after connecting the hoses.

Removal

1. Set the machine position for inspection and maintenance. (Refer to W1-5-1.)

CAUTION: Release any pressure in hydraulic oil tank (4). (Refer to W1-5-1.)

2. Remove bolts, washers (1) (6 used). Remove the cover (2) assembly and O-ring (3) from the upper part of hydraulic oil tank (4).

 : 17 mm

3. Place a container. Drain off hydraulic oil by using an oil feed pump.

 **NOTE:** Total oil amount of hydraulic oil tank (4): 190 L

4. Open cover (5).

IMPORTANT: Set the key switch to the OFF position. Wait 5 minute or longer, and then set battery disconnect switch (6) to the OFF position.

5. Set battery disconnect switch (6) to OFF position (a).

SECTION 3 UPPERSTRUCTURE

Group 4 Engine

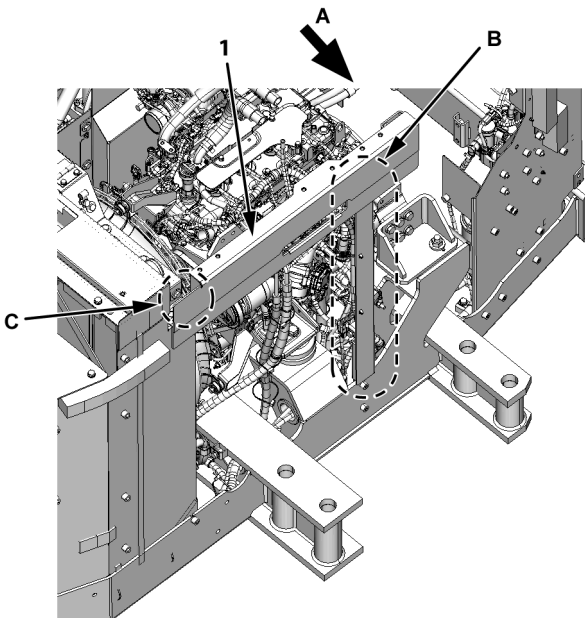

WDBR-03-04-023

View A

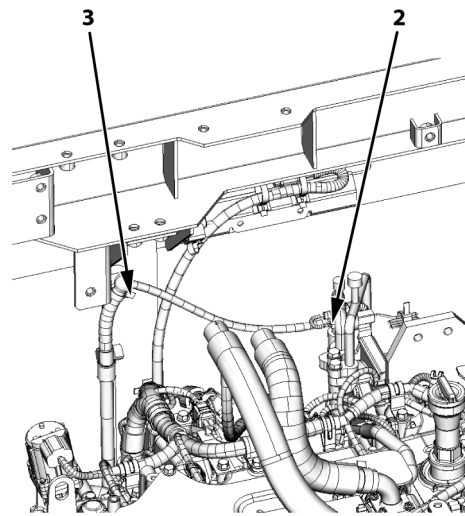

WDBR-03-04-022

Detail B

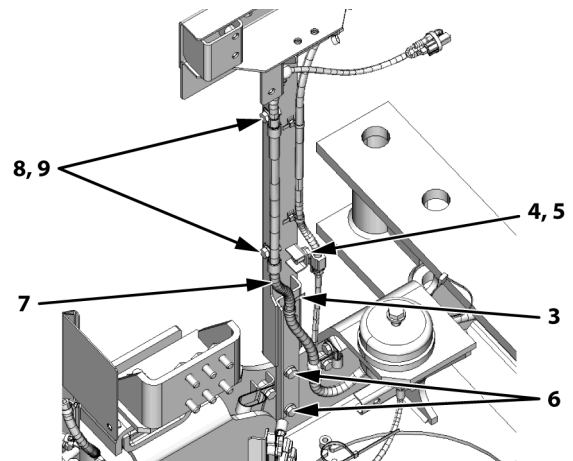

WDBR-03-04-024

45. Disconnect connector (2). Remove clip bands (3) (2 used).

46. Remove bolts, washers (8) (2 used) and clips (9) (2 used). Place harness (7) outside the work area.

 : 17 mm

47. Disconnect connector (4). Remove connect (4) from bracket (5).

48. Remove bolts, washers (6, 10) (2 used for each). Remove the support (1) assembly.

 : 17 mm

Detail C

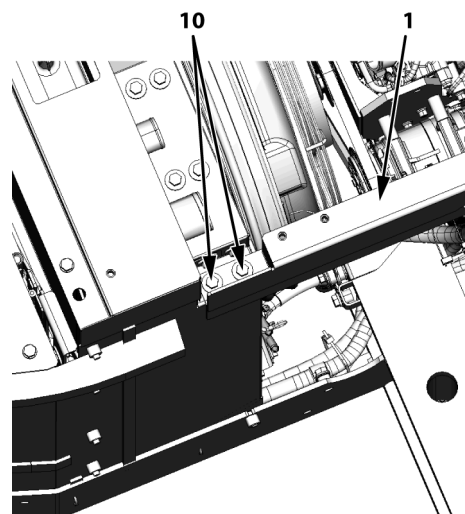

WDBR-03-04-025

SECTION 3 UPPERSTRUCTURE

Group 4 Engine

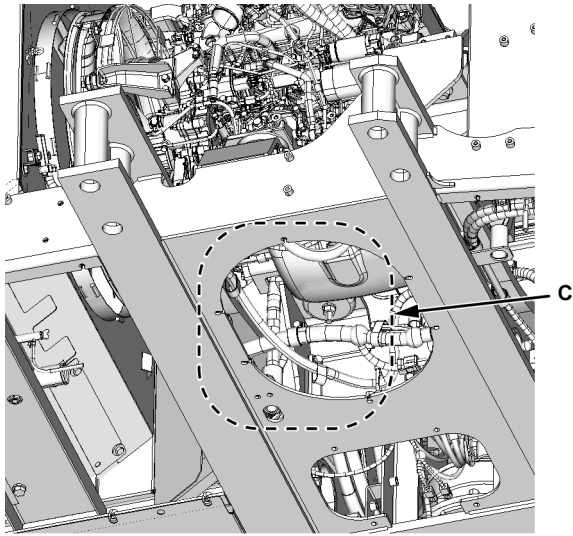

b- Machine Front Side



WDBR-03-04-038

Detail C

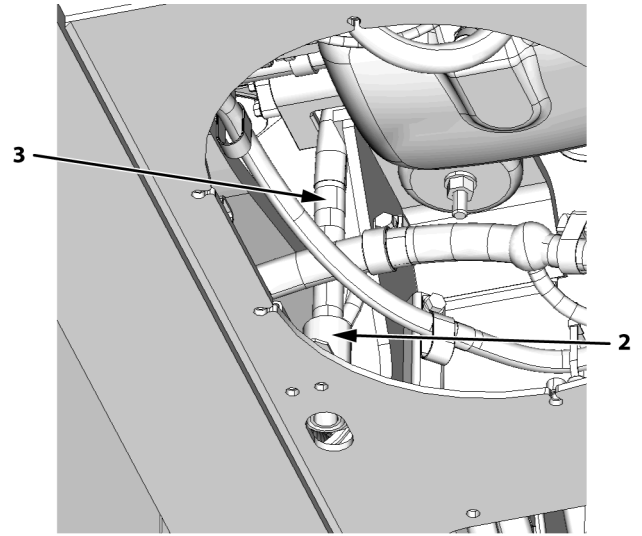

WDBR-03-04-039

6. Connect hose (3) to rubber (2).
7. Connect connectors (4) (6 used). Install clip band (5).
8. Install clip (7) with bolt, washer (6).

 : 17 mm

 : 50 N·m

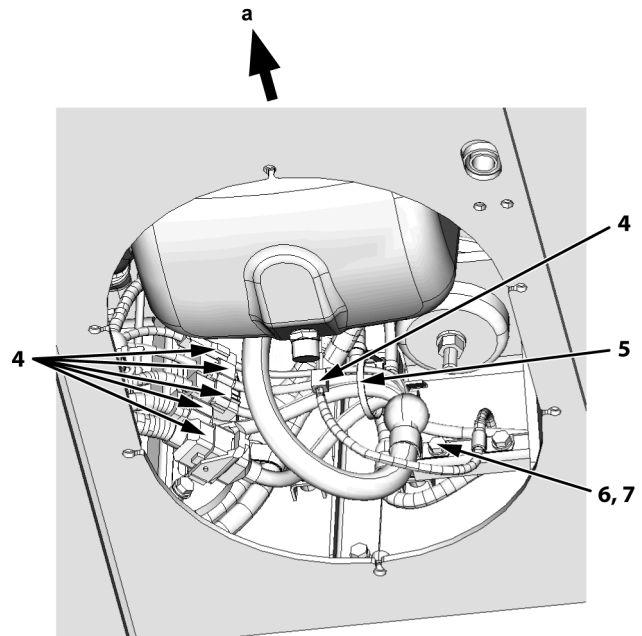

a- Machine Front Side

WDBR-03-04-046

SECTION 3 UPPERSTRUCTURE

Group 4 Engine

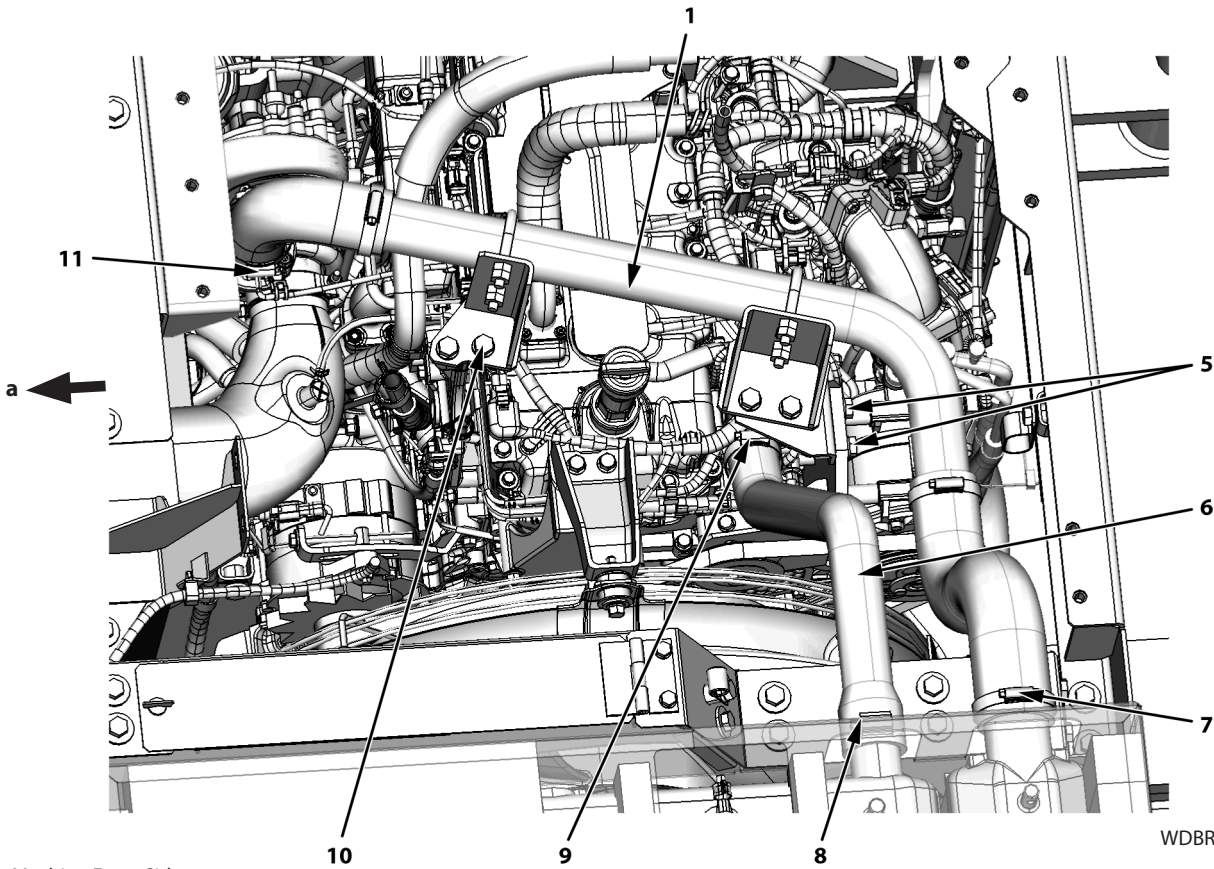

WDBR-03-04-012

a- Machine Front Side

38. Temporarily install the pipe (1) assembly with bolts, washers (5, 10) (2 used for each).

 : 17 mm

39. Connect the both ends of the pipe (1) assembly. Install clamps (7, 11).

 : 7 mm

 : 6 N·m

40. Tighten bolts, washers (5, 10) (2 used for each).

 : 17 mm

 : 50 N·m

41. Connect the both ends of hose (6). Install clamps (8, 9).

 : 7 mm

 : 6 N·m

 : 8 mm

 : 6 N·m

SECTION 3 UPPERSTRUCTURE

Group 8 Pump Device

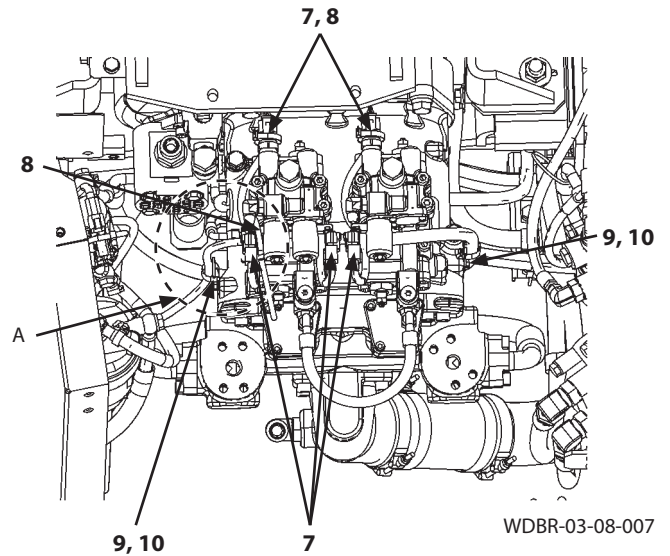
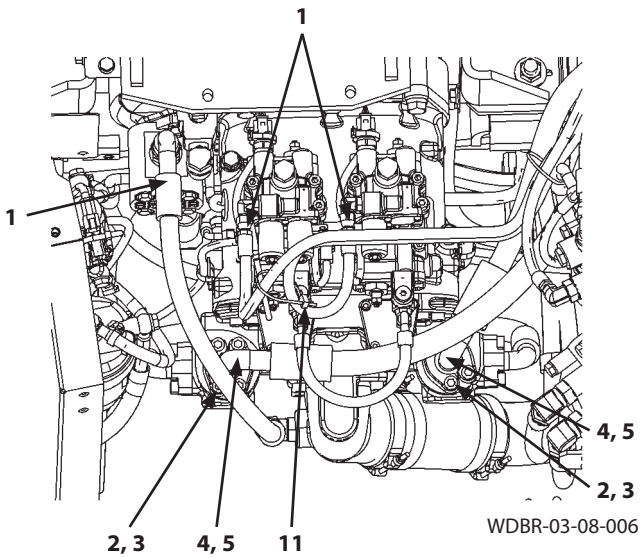

Detail A

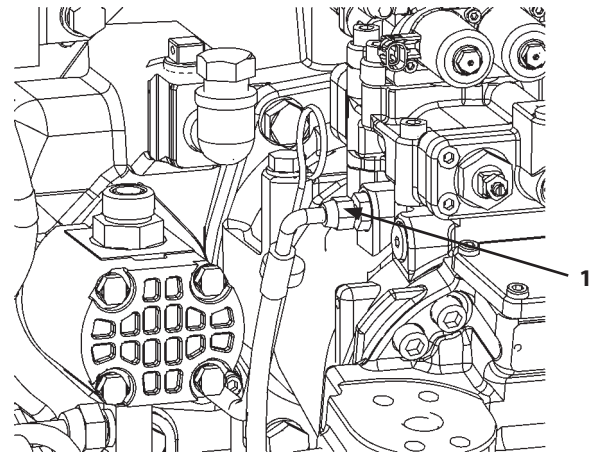

5. Remove clip band (11). Disconnect hoses (1) (4 used).

 : 17 mm, 19 mm, 36 mm

6. Remove socket bolts (2) (8 used) and flanges (3) (4 used). Disconnect hoses (4) (2 used). Remove O-rings (5) (2 used).

 : 10 mm

7. Remove clip bands (8) (3 used). Disconnect connectors (7) (5 used). Remove bolts, washers (9) (2 used) and clips (10) (2 used).

 : 10 mm

SECTION 3 UPPERSTRUCTURE

Group 8 Pump Device

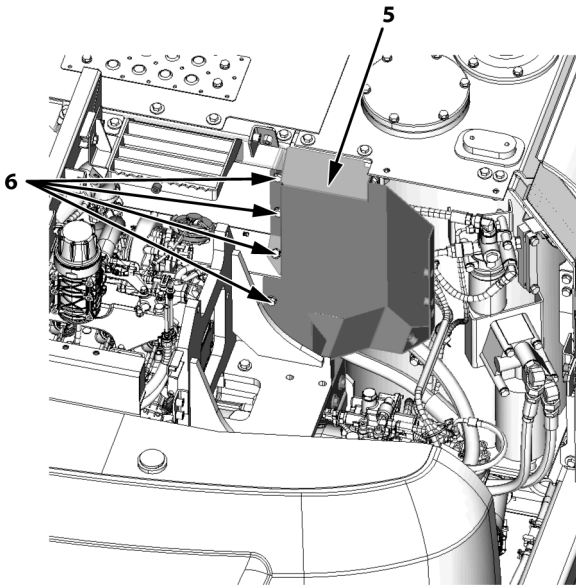

WDBR-03-08-005

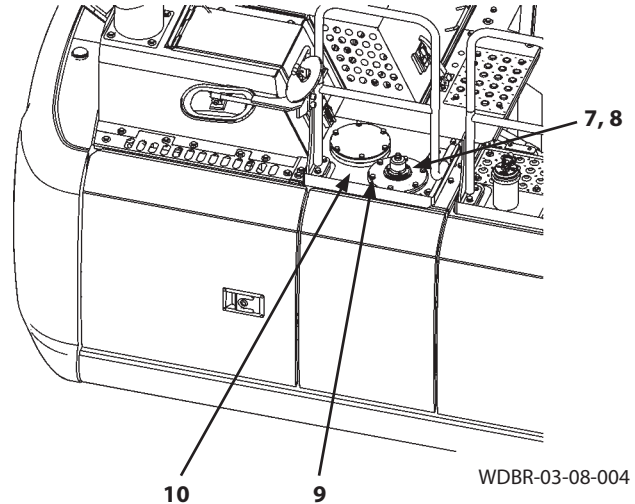

WDBR-03-08-004

20. Install cover (5) with bolts, washers (6) (4 used).

 : 17 mm

21. Install the aftertreatment device. (Refer to W3-14-1.)

22. Fill hydraulic oil tank (10) with hydraulic oil.

 **NOTE:** Total oil amount of hydraulic oil tank (10): 188 L

23. Install O-ring (8).

24. Install the cover (7) assembly on the top of hydraulic oil tank (10) with bolts, washers (9) (6 used).

 : 17 mm

 : 50 N·m

25. Bleed air from DEF defrosting piping. (Refer to W1-4-1.)

26. Bleed air from the hydraulic system. (Refer to W1-4-1.)

- Pump Air Bleed Plug

 : 27 mm

 : 95 N·m

IMPORTANT: Check the hydraulic oil level. Start the engine and check for any oil leaks.

IMPORTANT: Warm up the engine and increase the SCR exhaust temperature over 190 °C. Check the DEF hose for DEF leaks. In addition, check that DEF pressure increases up to approx. 9000 hpa by using the monitor. (Refer to T5-2 in the separated volume, Technical Manual.)

SECTION 3 UPPERSTRUCTURE

Group 8 Pump Device

30. Remove thrust ring (20) from pump casing (51).
31. Remove bearing nut (9) from shaft (13) by using the special tool (ST 3058).

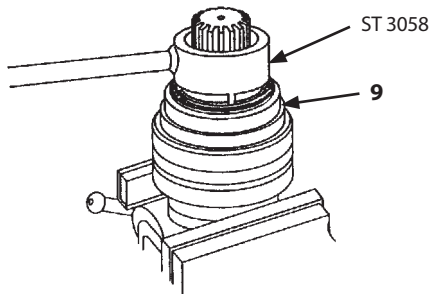

W137-02-04-023

IMPORTANT: Replace bearings (12, 85) and spacers (84, 87) as an assembly.

32. Remove bearings (10, 12, 85), spacers (84, 87), and ring (11) from shaft (13) by using a press.
33. Remove bearing nut (9), bearings (10, 12, 85), spacers (84, 87), and ring (11) from shaft (19) in the same way as step 31 and step 32.

CAUTION: Pump casing (51) weight: 42 kg

34. Attach nylon slings onto pump casing (51). Hoist and place pump casing (51) with the selector head (66) mounting side down.
35. Remove retaining rings (50) (2 used) and oil seals (49) (2 used) from pump casing (51).

36. Remove retaining ring (40) from gear casing (47). Remove retaining ring (41) from gear shaft (44).
37. Remove upper side ball bearing (42) and gear shaft (44) from gear casing (47) by using special tool (ST 1802).

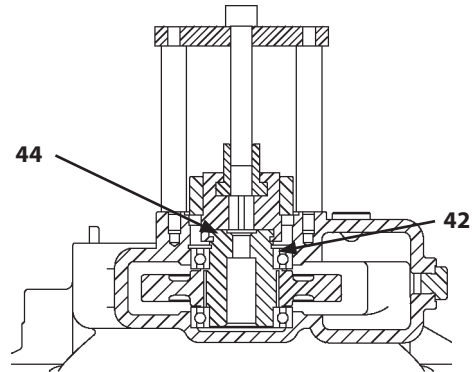

WDCA-03-08-031

38. Remove gear (43) and lower side ball bearing (42) from gear casing (47).
39. Install shackles to the outer bolt holes of gear casing (47). Attach nylon slings onto the shackles. Hoist and turn over gear casing (47).
40. Remove retaining ring (45) and oil seal (46) from gear casing (47).

SECTION 3 UPPERSTRUCTURE

Group 8 Pump Device

50. Install retaining ring (45) to gear casing (47).

51. Install O-ring (31) to plug (30). Install plug (30) to gear casing (47).

 : 22mm

52. Install a seal tape onto elbow (83). Install elbow (83) to gear casing (47). Add engine oil (Nippon Oil Corporation DH1 15W-40, DH2 15W-40, or equivalent) through the elbow (83) hole.

 **NOTE:** Amount of oil: 1.0 L

53. Install a seal tape onto plug (82). Install plug (82) to elbow (83).

 : 30 mm

 : 40 N·m

IMPORTANT: The breather hole of plug (25) is located at the left side, viewed from the front of gear casing (47).

54. Install a seal tape onto plug (25). Install plug (25) to gear casing (47).

 : 17 mm

 : 40 N·m

55. Install O-rings (80A, 81A) to pump 1 delivery pressure sensor (80) and pump 2 delivery pressure sensor (81). Install pump 2 delivery pressure sensor (81) and pump 1 delivery pressure sensor (80) to selector head (66).

 : 27 mm

 : 98 N·m

56. Connect the both ends of hose (79) to regulators (2, 6).

 : 22 mm

 : 35 N·m

57. Install level gauge (35) to pipe (34).

SECTION 3 UPPERSTRUCTURE

Group 8 Pump Device

Structure of Pilot Pump

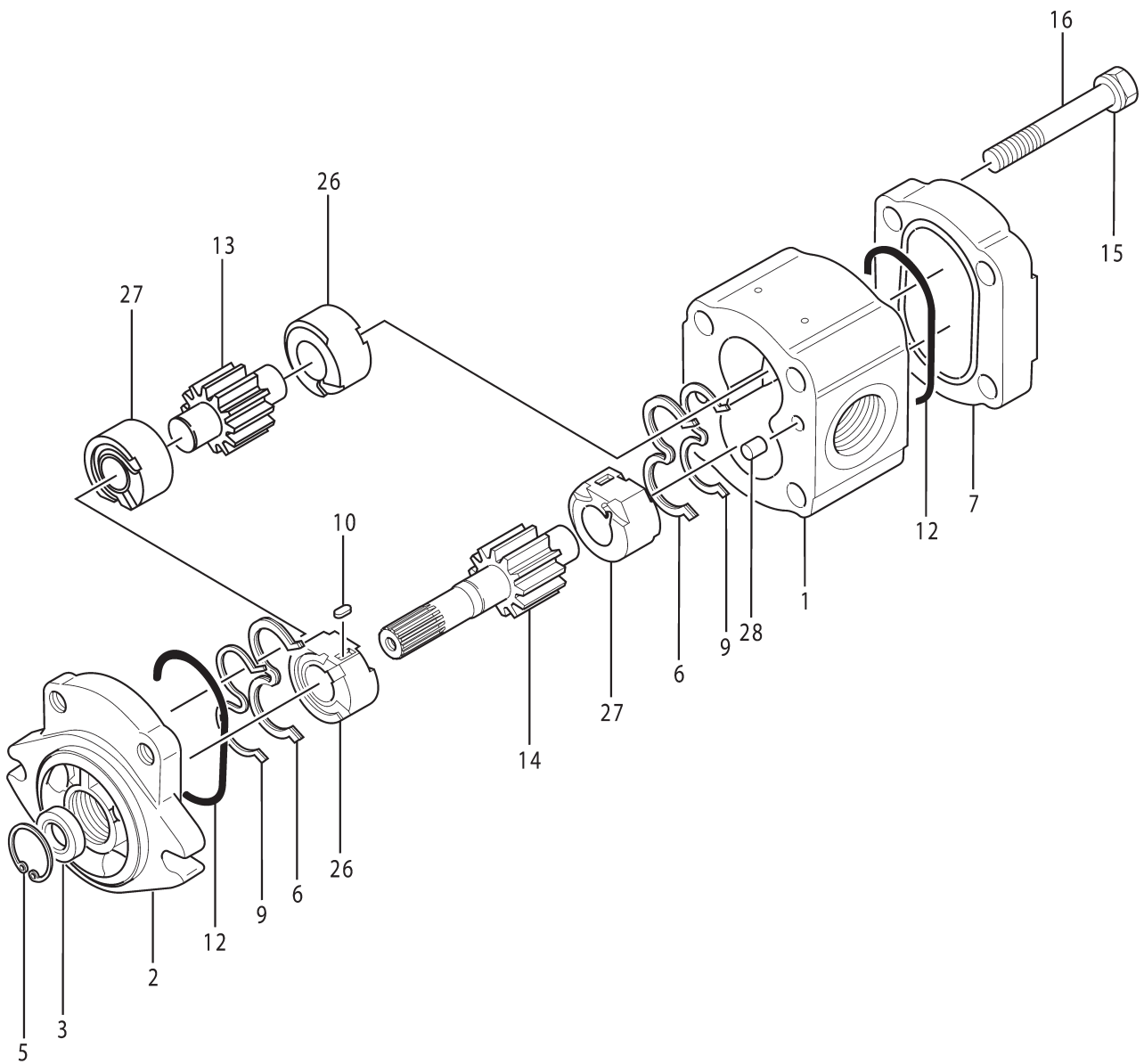

WDCA-03-08-015

SECTION 3 UPPERSTRUCTURE

Group 9 Control Valve

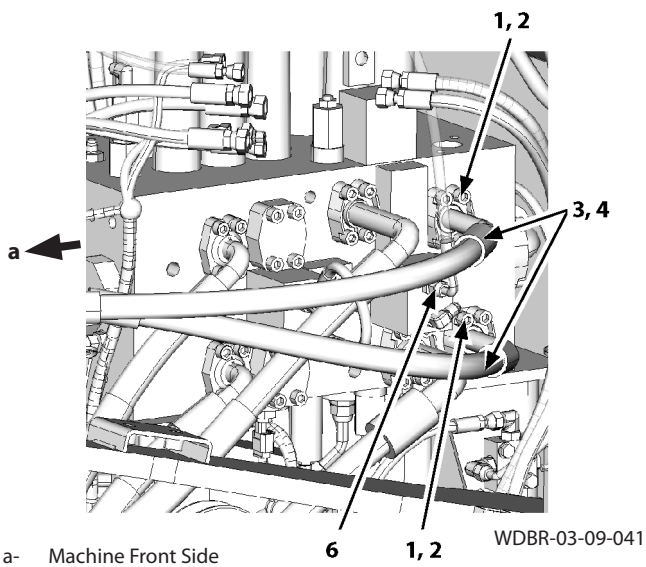

a- Machine Front Side

WDBR-03-09-041

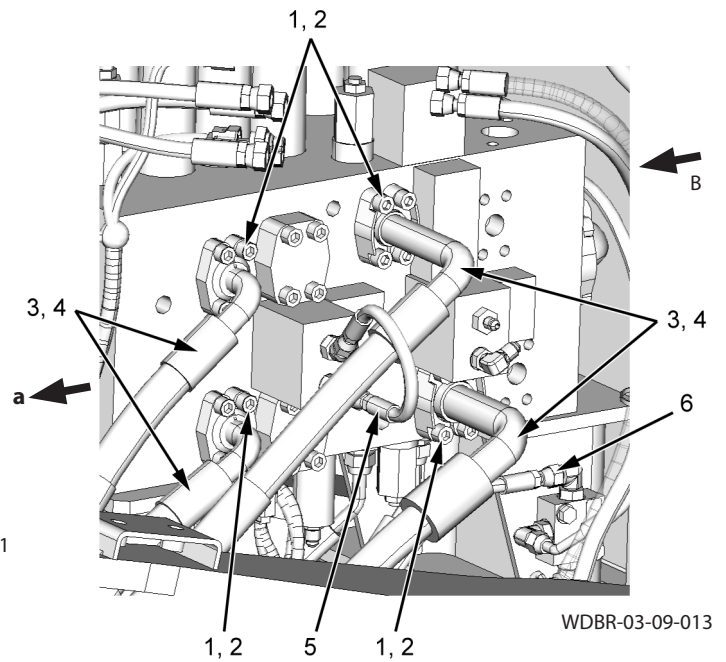

a- Machine Front Side

WDBR-03-09-013

29. Remove socket bolts (1) (24 used) and flanges (2) (12 used). Disconnect hoses (3) (6 used). Remove O-rings (4) (6 used).

 : 6 mm

30. Disconnect the both ends of hose (5).

 : 17 mm

31. Remove socket bolts (8) (4 used) and flanges (9) (2 used). Disconnect hose (7). Remove O-ring (10).

 : 10 mm

32. Disconnect hoses (6) (3 used).

 : 17 mm

View B

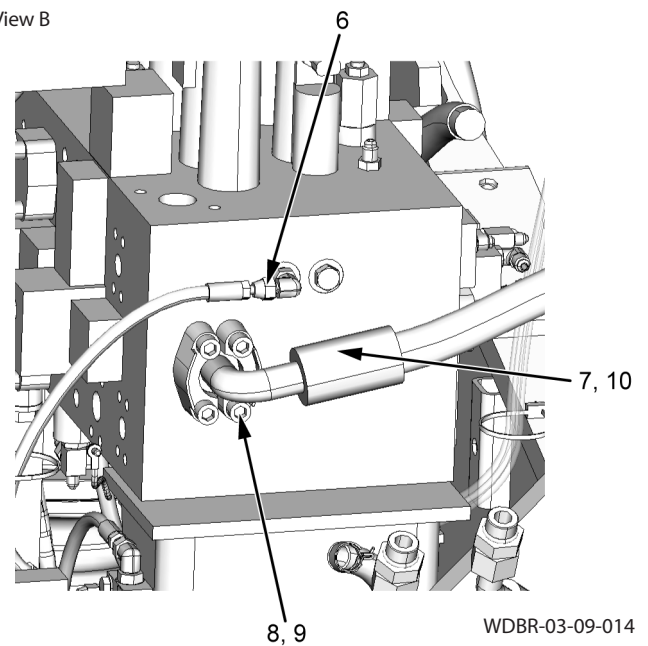

WDBR-03-09-014

SECTION 3 UPPERSTRUCTURE

Group 9 Control Valve

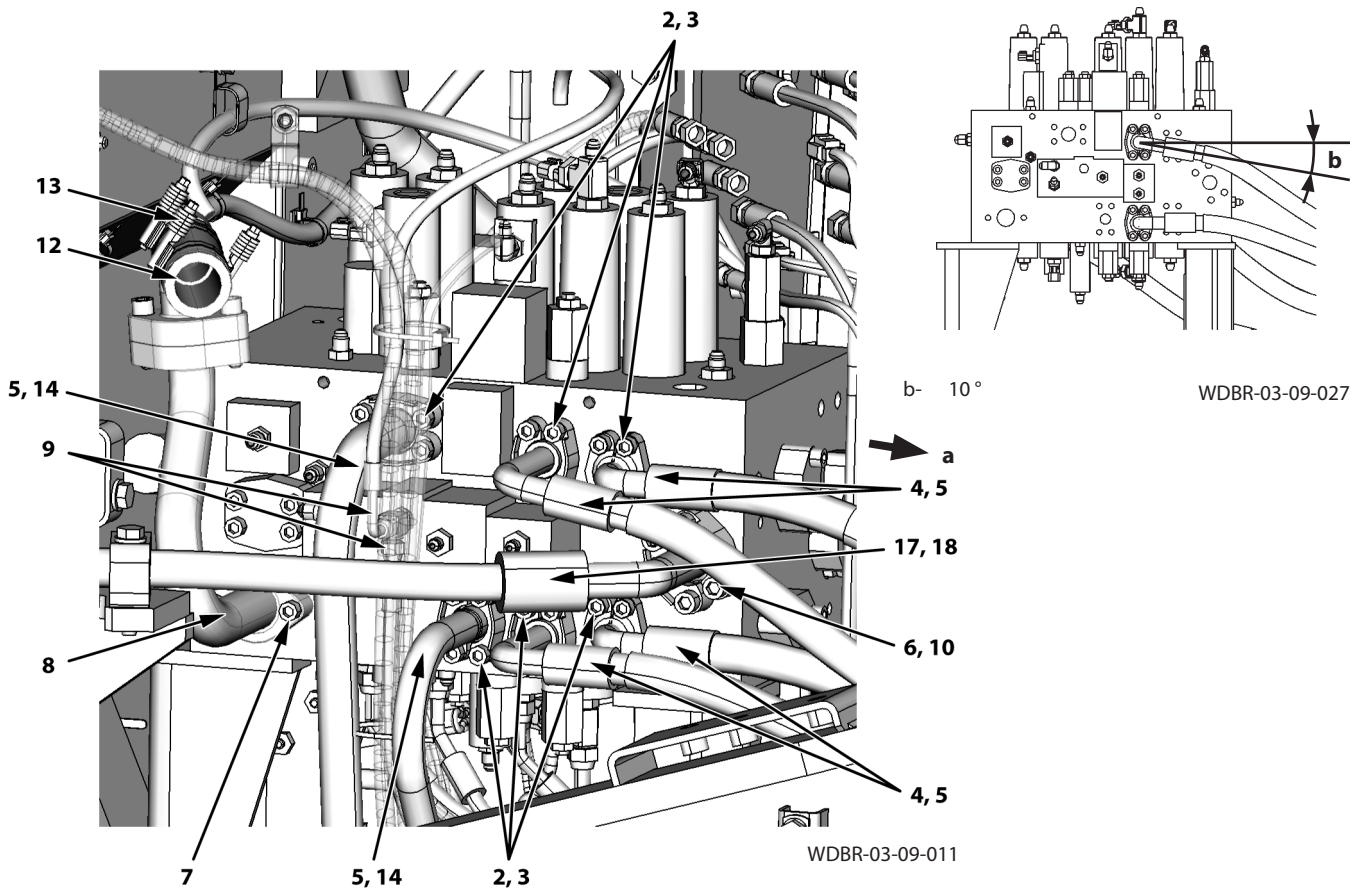

a- Machine Front Side

14. Install valve (16) and O-ring (15). Temporarily install the pipe (8) assembly, clamps (13) (4 used) at the both ends of hose (12), and socket bolts (7) (2 used).

NOTE: Do not drop valve (16) from pipe (8).

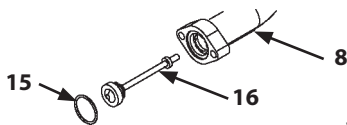

WDBE-03-09-011

15. Tighten socket bolts (7) (2 used).

: 8 mm

: 65 N·m

16. Tighten clamps (13) (4 used).

17. Install O-ring (18). Connect hose (17) with flanges (10) (2 used) and socket bolts (6) (4 used).

: 10 mm

: 90 N·m

IMPORTANT: Check the angle to connect the hose.

18. Install O-rings (5) (6 used). Connect hoses (4) (4 used) and pipes (14) (2 used) with flanges (3) (12 used) and socket bolts (2) (24 used).

: 8 mm

: 65 N·m

19. Connect hoses (9) (2 used).

: 17 mm

: 25 N·m

SECTION 3 UPPERSTRUCTURE

Group 9 Control Valve

Assembly of Housing

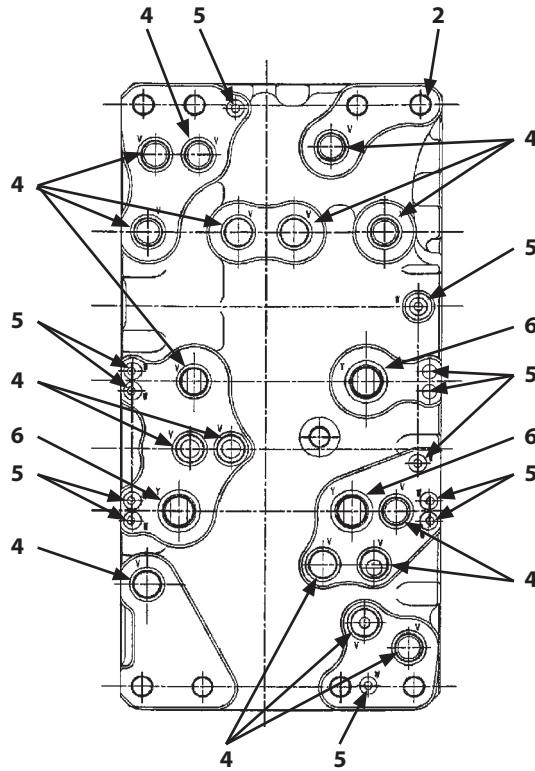

WDBR-03-09-029

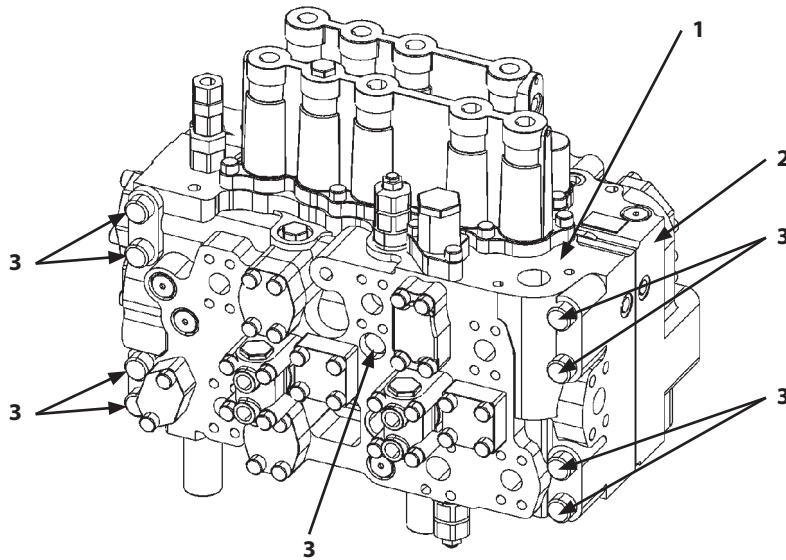

W1V1-02-05-001

1- Housing (B Side)
2- Housing (A Side)

3- Socket Bolt (9 Used)
4- O-Ring (16 Used)

5- O-Ring (12 Used)
6- O-Ring (3 Used)

SECTION 3 UPPERSTRUCTURE

Group 9 Control Valve

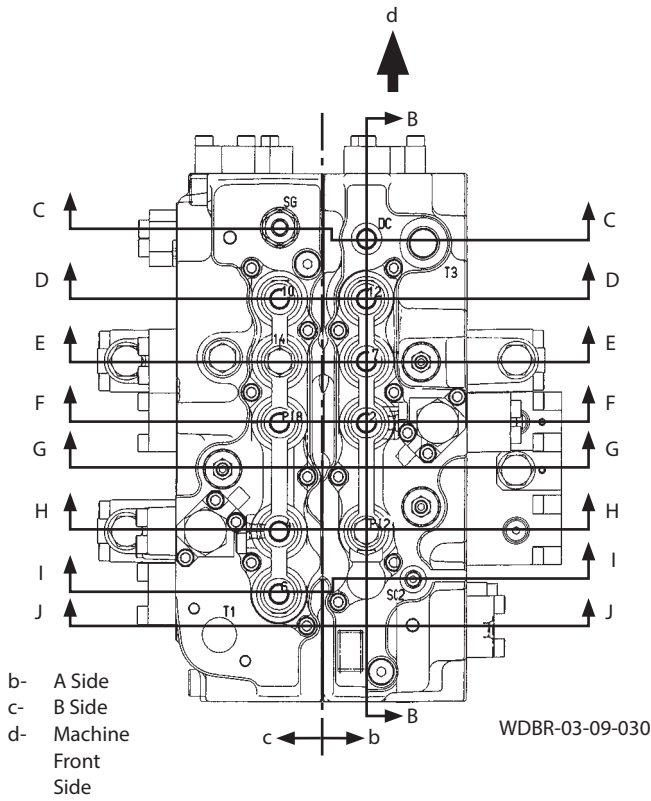

Section B-B

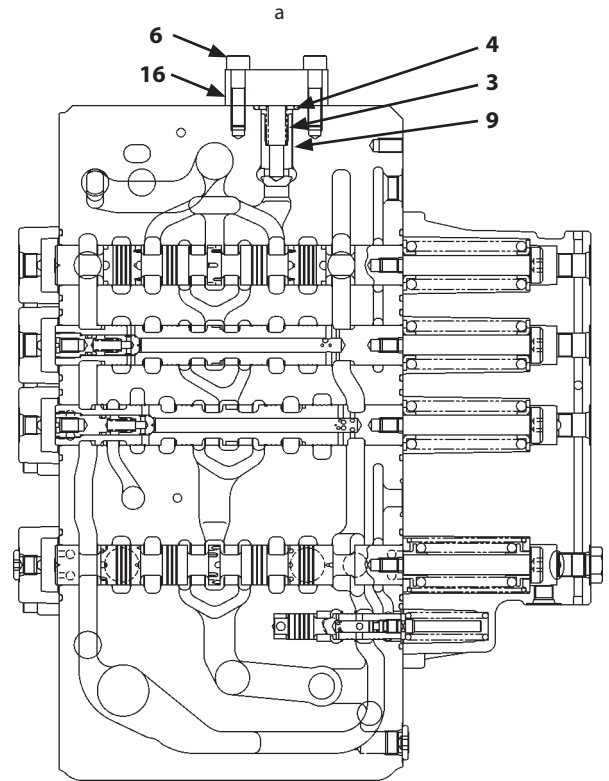

T1V1-03-03-002

Section D-D (A Side)

Section C-C (A Side)

Detail A

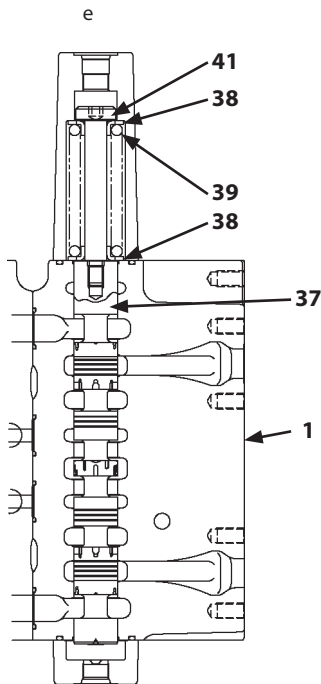

W1V1-02-05-035

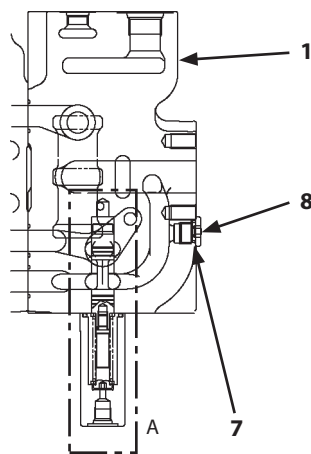

W1V1-02-05-038

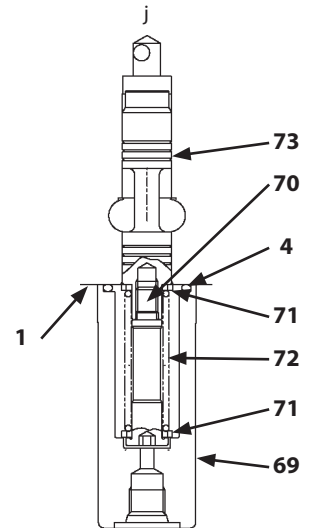

W1V1-02-05-040

SECTION 3 UPPERSTRUCTURE

Group 9 Control Valve

Disassembly of Control Valve (B Side)

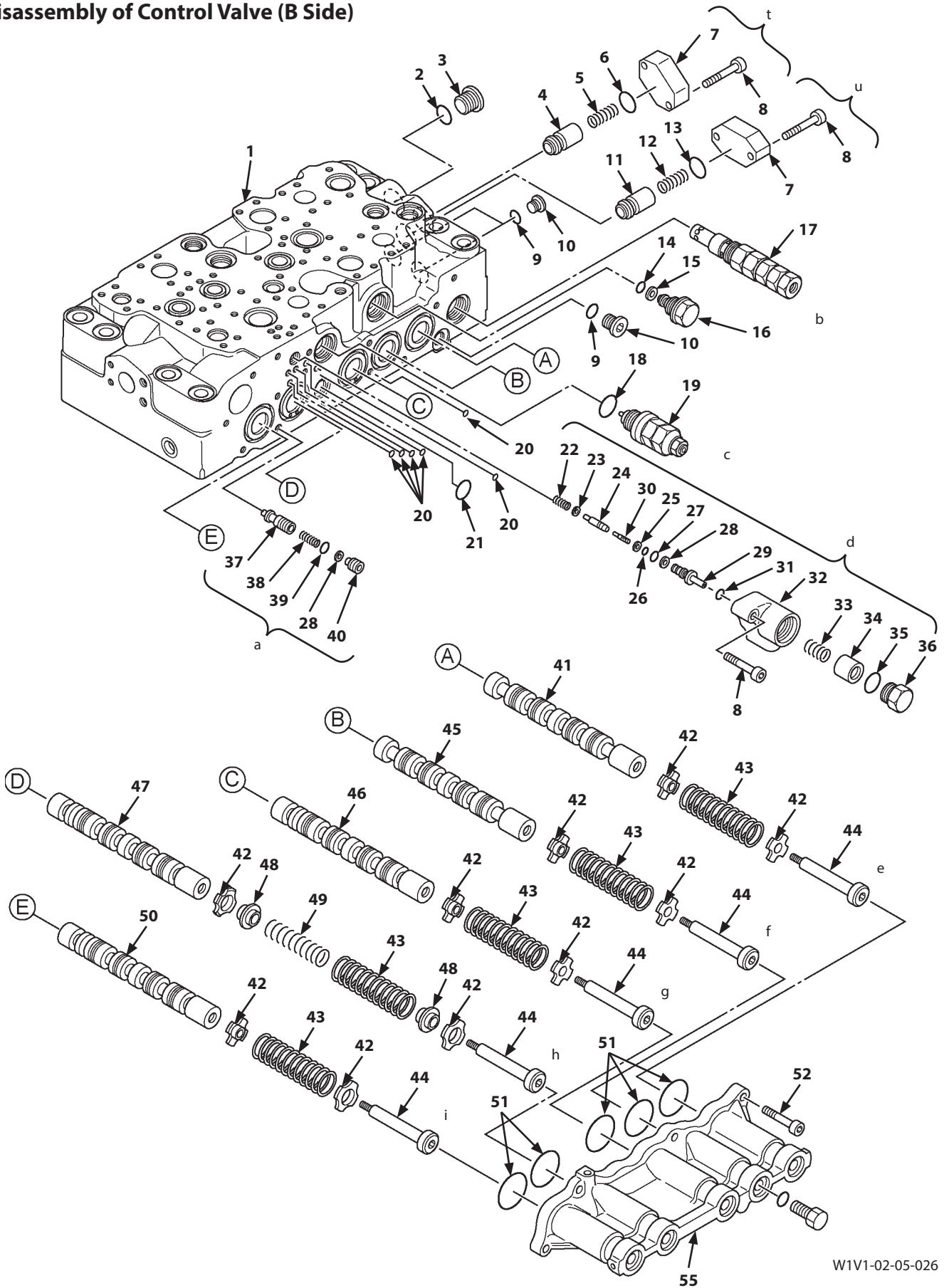

W1V1-02-05-026

CLICK HERE TO **DOWNLOAD** THE COMPLETE MANUAL

- Thank you very much for reading the preview of the manual.
- You can download the complete manual from: www.heydownloads.com by clicking the link below



- Please note: If there is no response to CLICKING the link, please download this PDF first and then click on it.

CLICK HERE TO **DOWNLOAD** THE COMPLETE MANUAL

SECTION 3 UPPERSTRUCTURE

Group 9 Control Valve

Section H-H (B Side)

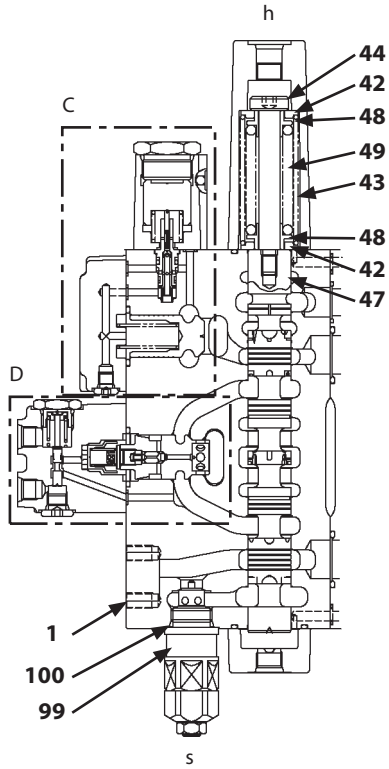

W1V1-02-05-051

Section I-I (B Side)

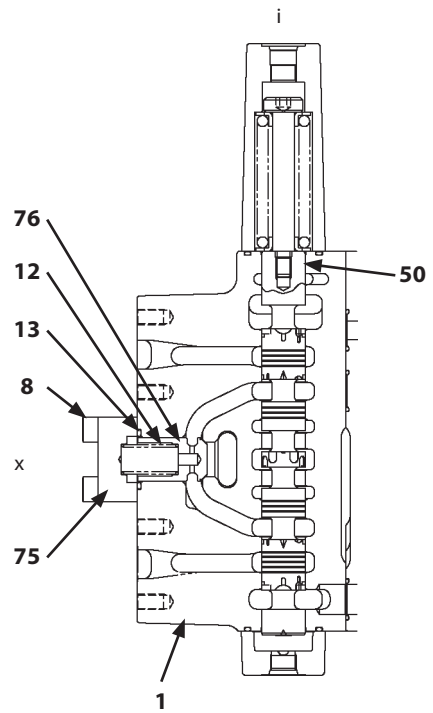

W1V1-02-05-052

Detail C

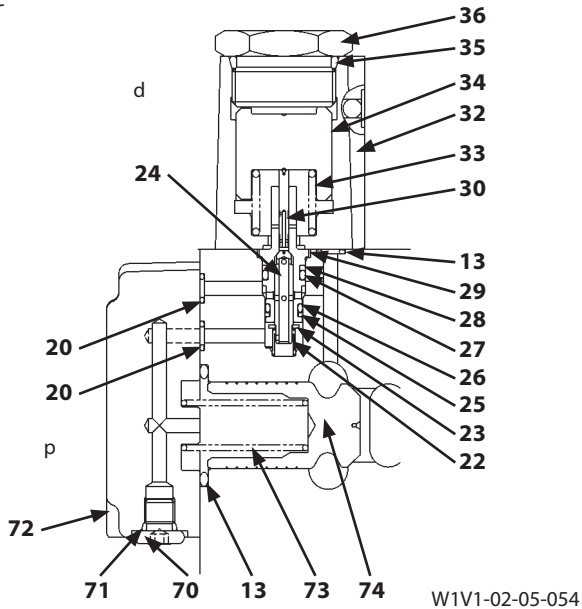

W1V1-02-05-054

Detail D

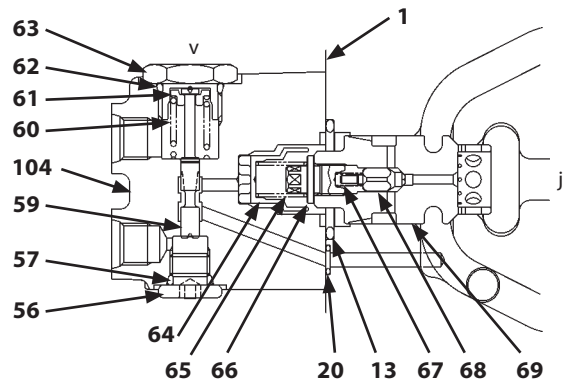

WDBR-03-09-034

SECTION 3 UPPERSTRUCTURE

Group 10 Swing Device

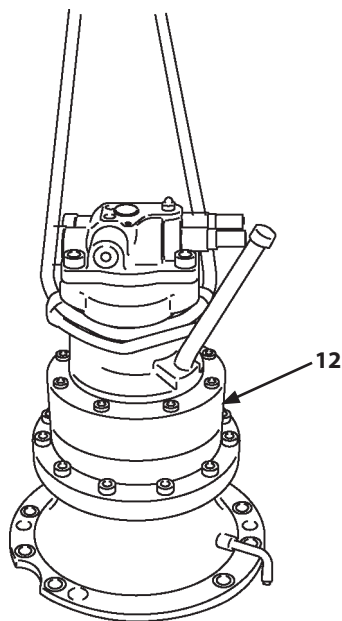

WDAD-03-10-004

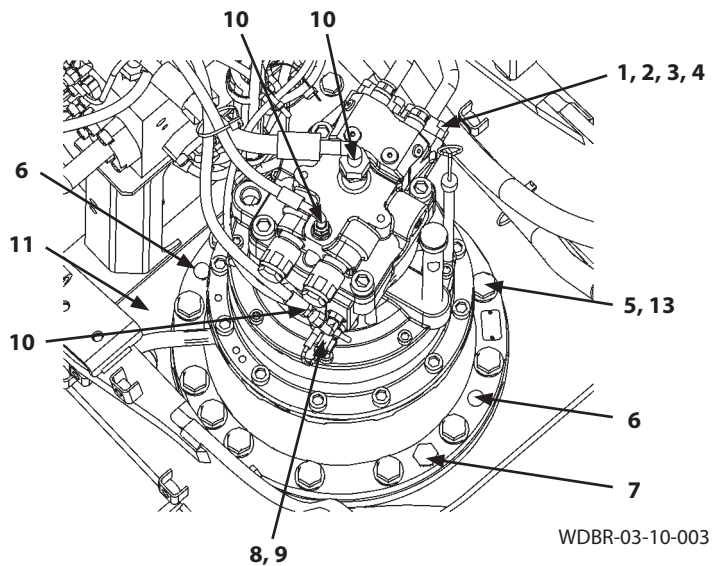

WDBR-03-10-003

Installation

1. Install all removed adapters to swing device (12).

CAUTION: Swing device (12) weight: 220 kg

2. Apply THREEBOND #1102 to the main frame (11) mounting surface of swing device (12). Attach nylon slings onto the body of swing motor. Hoist swing device (12).
3. Fit the positions of knock pin (6) holes (2 places). Install swing device (12) to main frame (11).
4. Apply THREEBOND #1102 to knock pins (6) (2 used). Install knock pins (6) (2 used) to main frame (11).
5. Install swing device (12) with washers (13) (14 used) and bolts (5) (14 used).

 : 30 mm

 : 500 N·m

6. Install plugs (7) (2 used).

 : 30 mm

7. Install O-rings (4) (2 used). Connect hoses (3) (2 used) with flanges (2) (4 used) and socket bolts (1) (8 used).

 : 8 mm

 : 50 N·m

8. Connect hoses (10) (3 used).

 : 22 mm

 : 40 N·m

 : 36 mm

 : 180 N·m

9. Connect connector (8). Install clip band (9).

SECTION 3 UPPERSTRUCTURE

Group 10 Swing Device

CAUTION: The housing (26) assembly weight: 110 kg

IMPORTANT: Check that the flange surface of housing (26) does not come in contact with special tool (ST 5097).

15. Hoist and place the housing (26) assembly onto special tool (ST 5097). Install the housing (26) assembly to special tool (ST 5097) with the bolts (M20, Pitch 2.5 mm) (2 used). Secure special tool (ST 5097) to a workbench in order to receive the reaction force.

 : 30 mm

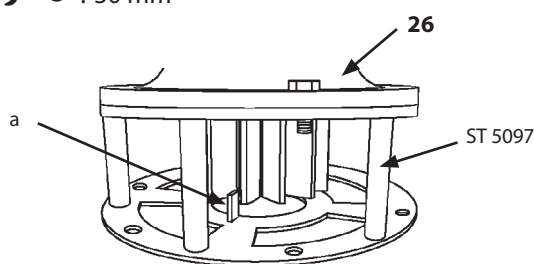

W178-02-11-134

a- Stopper

IMPORTANT: Check the direction to install bearing nut (15).

16. Apply grease to the thread part of bearing nut (15). Place it onto shaft (31). At this time, face the stepped end side of bearing nut (15) to the roller bearing (14) side.
17. Tighten bearing nut (15) by using special tool (ST 2926).

 : 500 N·m

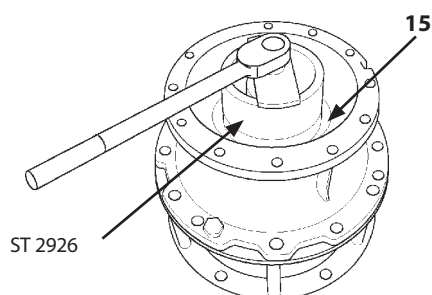

W178-02-11-146

18. Remove the bolts (M20, Pitch 2.5 mm) (2 used) which secure housing (26) and special tool (ST 5097).

 : 30 mm

19. Turn housing (26) both clockwise and counterclockwise by 5 turns. Tap housing (26) by using a plastic hammer several times.
20. Install housing (26) to special tool (ST 5097) with the bolts (M20, Pitch 2.5 mm) (2 used).

 : 30 mm

21. Tighten bearing nut (15) by using special tool (ST 2926).

 : 500 N·m

22. Repeat step 18 to step 21 two to three times and bearing nut (15) and bearings of roller bearings (14, 27) can fit.
23. Remove the bolts (M20, Pitch 2.5 mm) (2 used) which secure housing (26) and special tool (ST 5097).

 : 30 mm

CAUTION: The housing (26) assembly weight: 110 kg

24. Hoist and place the housing (26) assembly onto a flat stand. When the housing (26) assembly is placed, check that the contacting position of oil seal (28) on the sleeve (29) outer circumference does not move up and down. In case the contacting position of oil seal (28) moves up and down, bearing nut (15) is tightened insufficiently. Repeat step 17 to step 23 again.
25. Install housing (26) to special tool (ST 5097) with the bolts (M20, Pitch 2.5 mm) (2 used).

 : 30 mm

SECTION 3 UPPERSTRUCTURE

Group 11 Pilot Valve

Removal and Installation of Pilot Valve (Left)

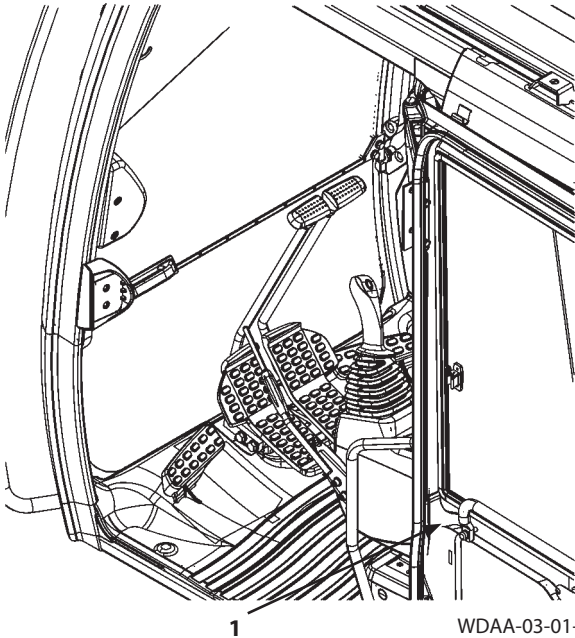

WDAA-03-01-023

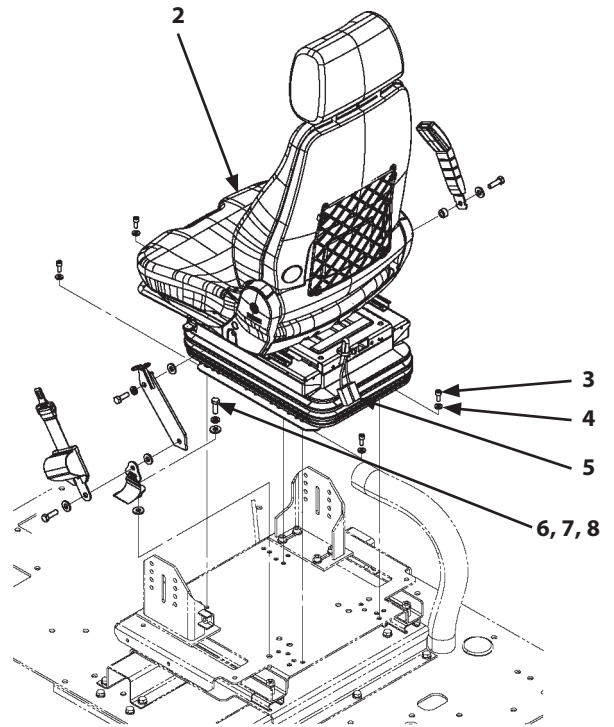

WDDQ50-03-11-001

IMPORTANT: The hoses and pipes contain hydraulic oil. When removing the hoses and pipes, receive oil with a container in order to avoid spilling oil.

IMPORTANT: Cap the open ends in case the hoses and pipes have been disconnected. In addition, attach identification tags onto the connectors, hoses, and pipes for assembling. If the clips which secure the hoses have been removed, install the clips after connecting the hoses.

Removal

1. Set the machine position for inspection and maintenance. (Refer to W1-5-1.)

CAUTION: Release any pressure in the hydraulic oil tank. (Refer to W1-5-1.)

2. Open door (1).
3. Disconnect connectors (5) (2 used).

4. Remove bolt (6), spring washer (7), and washers (8) (2 used).

 : 5/8 in

CAUTION: Seat (2) weight: 45 kg

5. Remove socket bolts (3) (4 used) and washers (4) (4 used). Remove seat (2).

 : 6 mm

SECTION 3 UPPERSTRUCTURE

Group 11 Pilot Valve

Installation of Lever Assembly

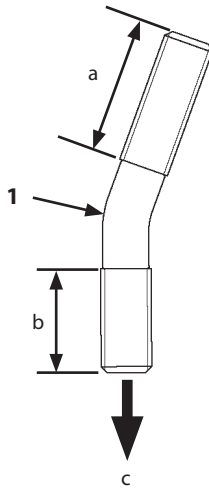



WDDQ50-03-11-009

a- 33 mm
b- 25 mm

c- Pilot Valve Side

24. Install shaft (1) to lever (2) with lock nut (5). (except the machine with AFL attached)

 : 19 mm

 : 30 N·m

25. Install shaft (1) to lever (2) with spring pin (6). (only the machine with AFL attached)

26. Install the lever (2) assembly to pilot valve (3) with lock nut (4).

 : 19 mm

 : 40 N·m

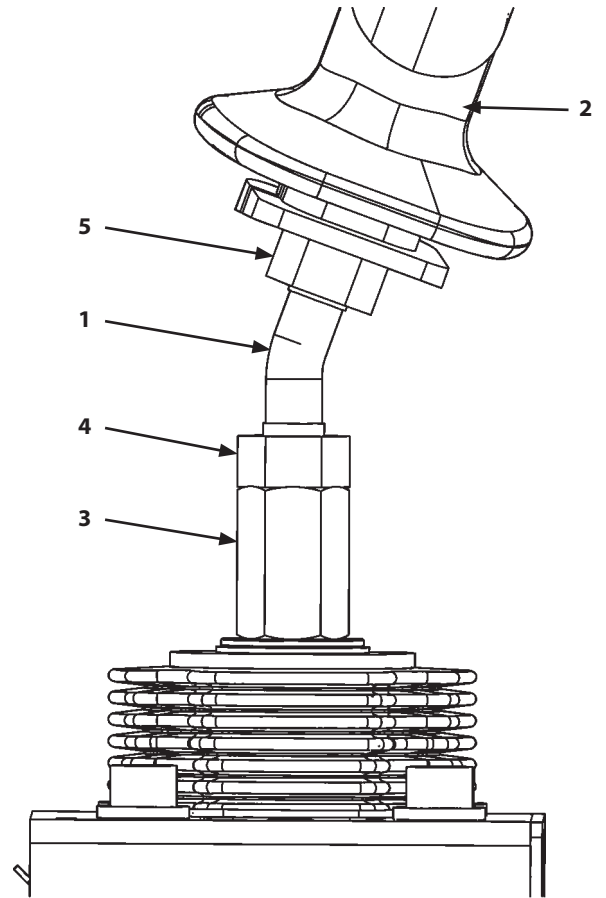

WDDQ50-03-11-010

Machine with AFL Attached

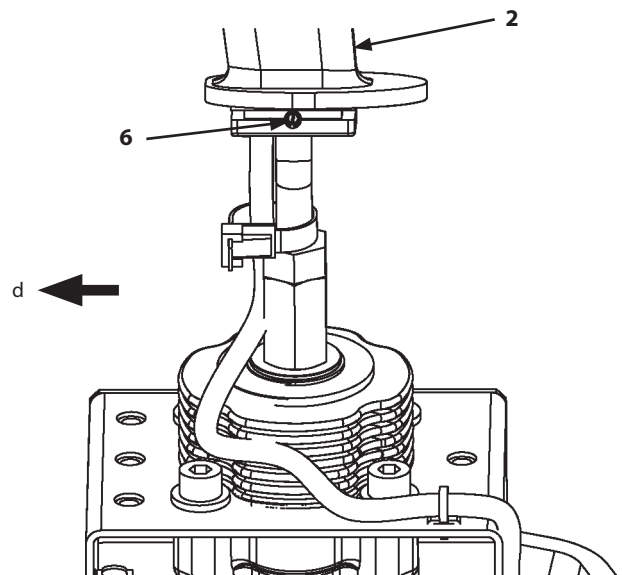

WDDQ50-03-11-007

d- Machine Front Side

SECTION 3 UPPERSTRUCTURE

Group 11 Pilot Valve

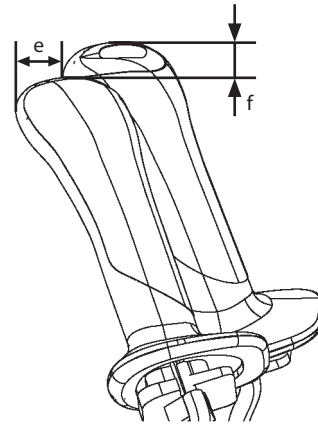
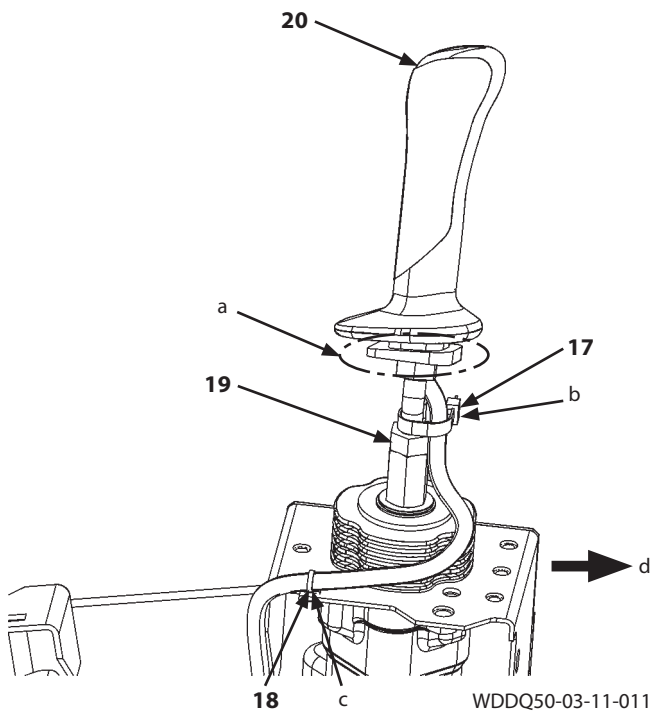

e- Less than 10 mm
f- Less than 10 mm

WDDQ50-03-11-008

- b- Wire harness length from position (a): 35 mm
c- Wire harness length from position (b): 150 mm
d- Machine Front Side

IMPORTANT: If the lever (20) assembly has been disassembled, perform step 24 to step 26.

4. Adjust the grip mounting position at the right and left sides so that the installation error is less than 10 mm. Install the lever (20) assembly with lock nut (19).

 : 19 mm

 : 45 N·m

IMPORTANT: Check the direction to install the wire harness.

5. Install clip bands (18, 17) as illustrated.

SECTION 3 UPPERSTRUCTURE

Group 11 Pilot Valve

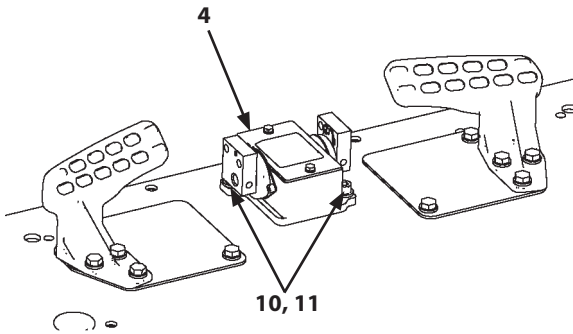

WDC150-03-11-004

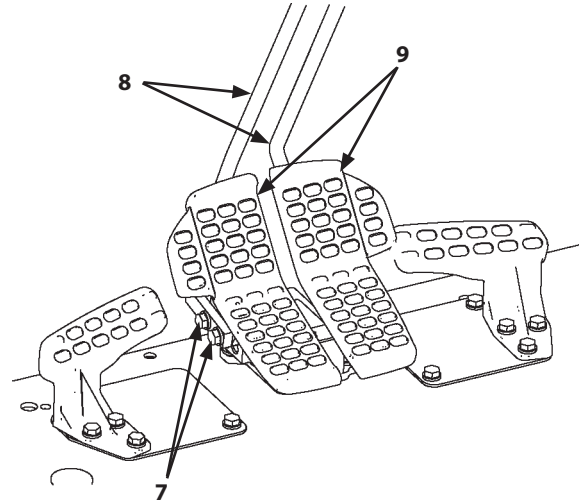

WDC150-03-11-003

Installation

1. Install all removed adapters to pilot valve (4).
2. Install pilot valve (4) with washers (11) (2 used) and socket bolts (10) (2 used).

 : 8 mm

 : 50 N·m

3. Install pedals (9) (2 used) and levers (8) (2 used) with bolts, washers (7) (4 used).

 : 17 mm

 : 50 N·m

SECTION 3 UPPERSTRUCTURE

Group 11 Pilot Valve

⚠ CAUTION: Metal fragments may fly off when a hammer is used. Wear necessary protection, such as goggles, hard hats, etc in order to prevent personal injury.

IMPORTANT: Place a stand under bracket (11) and receive a reaction force. If holder (7) bears the reaction force, strong force acts on pin (35). Therefore, pin (35) may be deformed.

9. Place a stand under bracket (11). The inner surfaces of the spring pins (12, 13) holes on bracket (11) are stepped-shape. The spring pin can only be removed in one direction. Tap and remove spring pins (12, 13) from bracket (11) at the same time by using special tool (ST 1237). Remove bracket (11) from pin (35). Do not remove spring pin (10) with bracket (11) attached unless necessary. The hole end of spring pin (10) has been crimped.

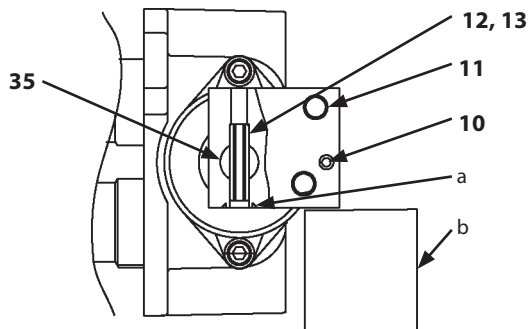

W176-02-07-019

- a - Crimped Position
- b - Stand

10. Remove socket bolts (9) (2 used) and spring washers (8) (2 used). Remove damper (32) and rubber seat (31) from pin (35). O-ring (34) is removed together.

 : 5 mm

11. Remove O-ring (33) from pin (35).
12. Remove other bracket (11) in the same way as step 9 to step 11.
13. Place holder (7) with the casing (23) mounting surface up.

⚠ CAUTION: Metal fragments may fly off when a hammer is used. Wear necessary protection, such as goggles, hard hats, etc in order to prevent personal injury.

14. The holes of spring pins (3, 4) (2 used for each) in cam (5) are stepped-shape. Tap the bottom of cam (5) and remove spring pins (3, 4) (2 used for each) from cams (5) (2 used) at the same time by using special tool (ST 1237). As the holes of spring pins (3, 4) (2 used for each) are crimped, spring pins (3, 4) may feel tight when removing.

SECTION 3 UPPERSTRUCTURE

Group 12 Solenoid Valve

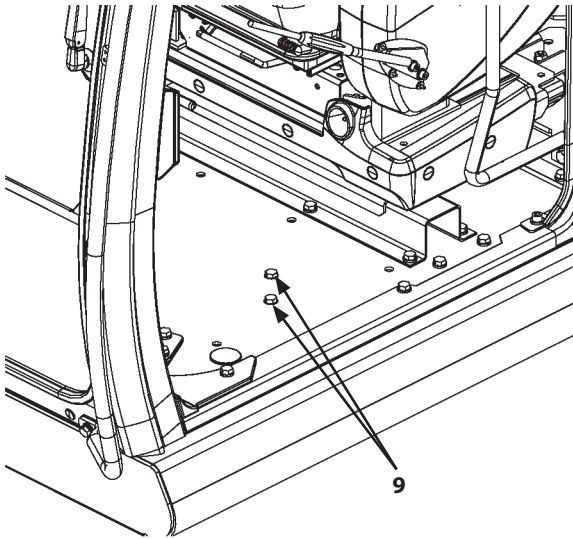

WDAA-03-13-007

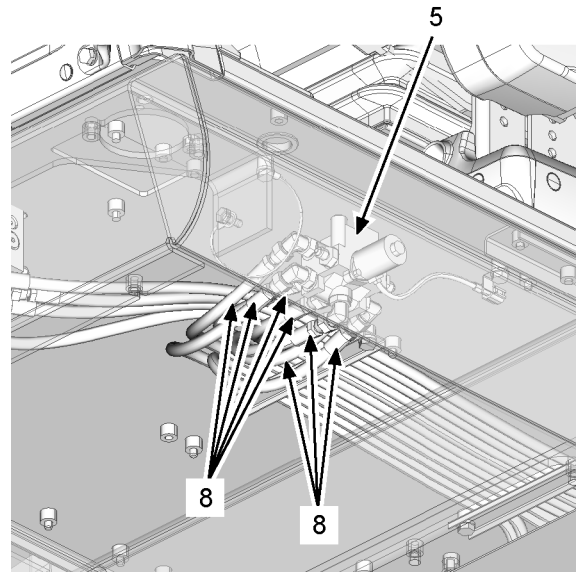

WDAA-03-13-008

Installation

1. Install all removed adapters to pilot shut-off solenoid valve (5).
2. Install pilot shut-off solenoid valve (5) with bolts, washers (9) (2 used).

 : 17 mm

 : 50 N·m

3. Connect hoses (8) (7 used).

 : 19 mm

 : 30 N·m

SECTION 3 UPPERSTRUCTURE

Group 12 Solenoid Valve

Disassembly of Pilot Shut-Off Solenoid Valve

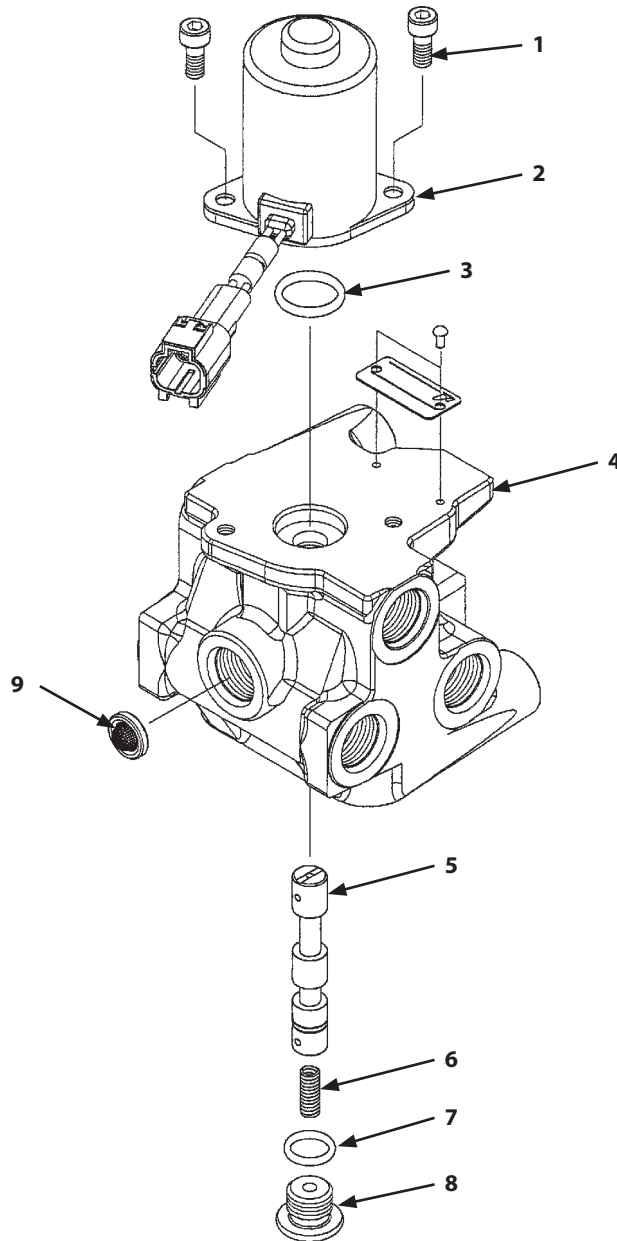

WDAA-03-13-014

1- Socket Bolt (2 Used)
2- Solenoid
3- O-Ring

4- Body
5- Spool
6- Spring

7- O-Ring
8- Plug
9- Filter

SECTION 3 UPPERSTRUCTURE

Group 13 Signal Control Valve

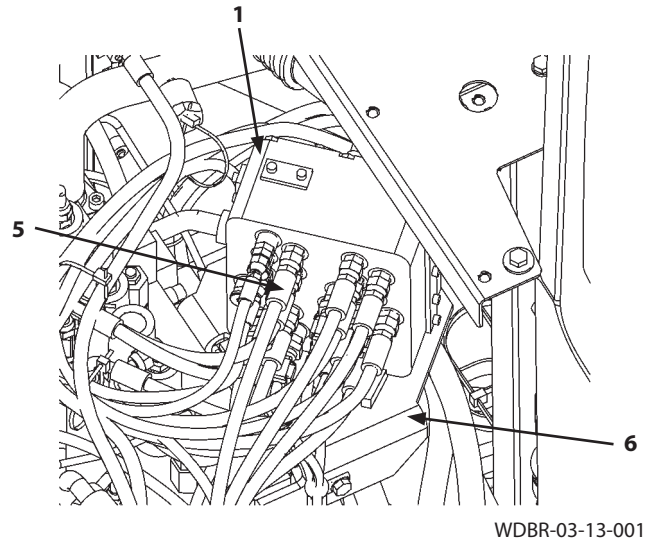
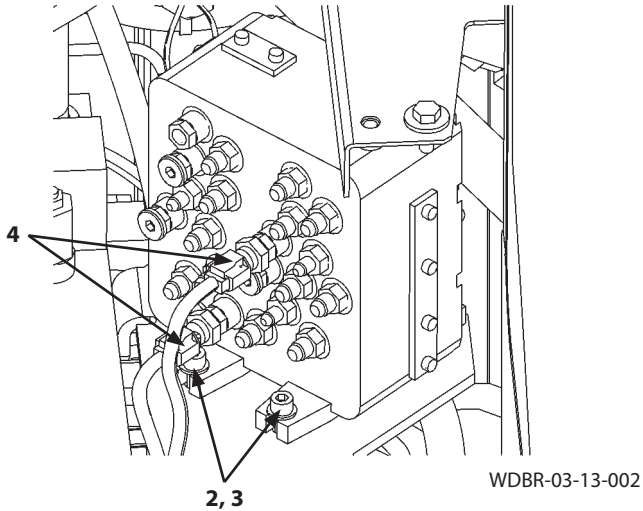

Installation

1. Install all removed adapters to signal control valve (1).
2. Install signal control valve (1) to bracket (6) with washers (3) (4 used) and socket bolts (2) (4 used).

 : 8 mm

 : 50 N·m

3. Connect hoses (5) (34 used) to signal control valve (1).

 : 17 mm

 : 25 N·m

 : 19 mm

 : 30 N·m

4. Connect connectors (4) (2 used).

SECTION 3 UPPERSTRUCTURE

Group 14 Aftertreatment Device

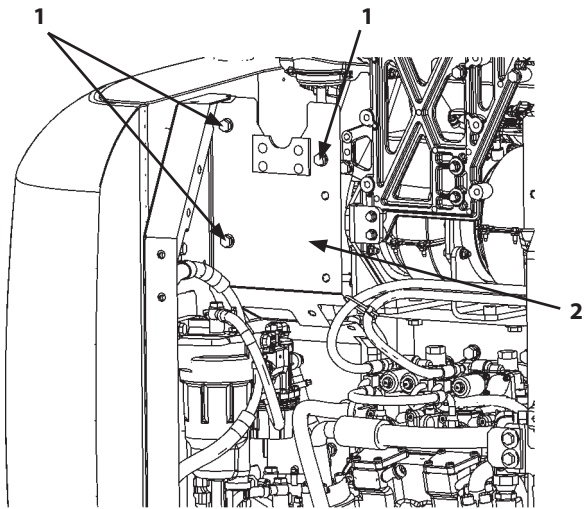

WDBR-03-14-013

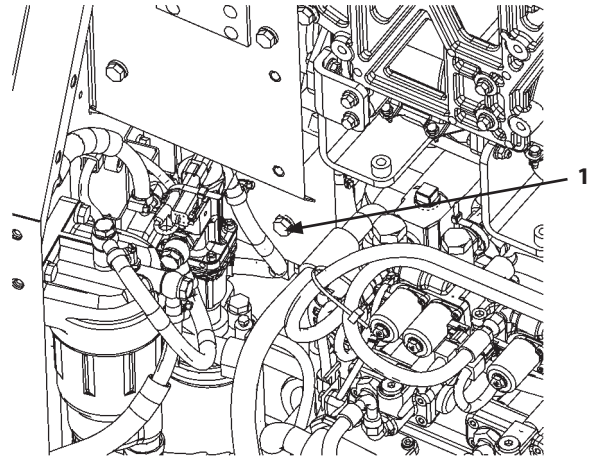

WDBR-03-14-014

19. Remove bolts, washers (1) (4 used). Remove cover (2).

 : 17 mm

SECTION 3 UPPERSTRUCTURE

Group 14 Aftertreatment Device

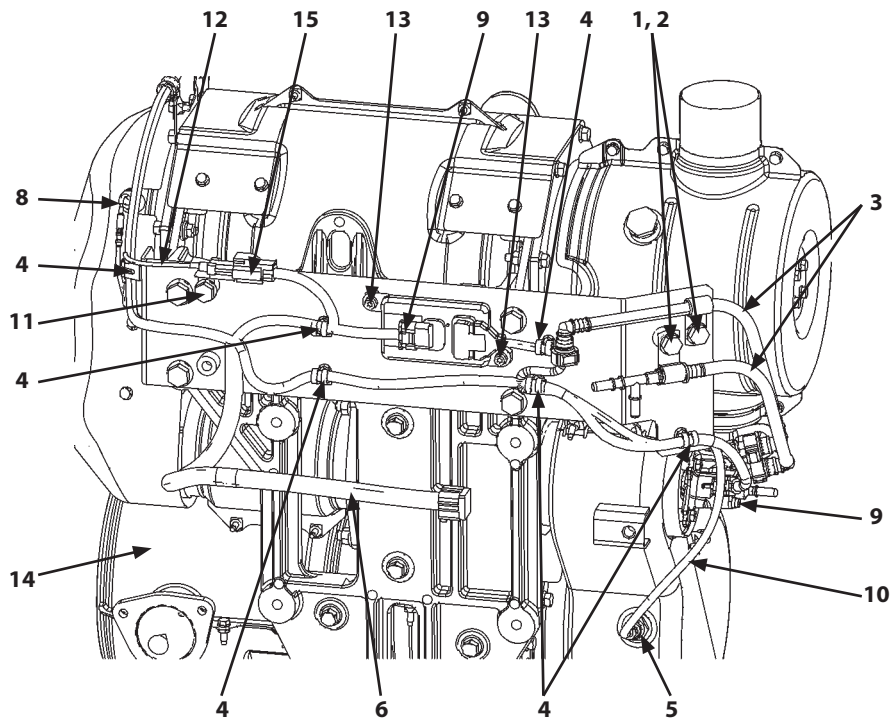

WDAQ-03-14-025

The machine equipped with AR-4JJ1XASA-01 engine

8. Apply anti-seize to the thread part of sensor (8).

 *NOTE: Anti-seize has been applied to new sensor (8).*

9. Install sensor (8) to aftertreatment device (14).

 : 13 mm

 : 30 N·m

10. Apply anti-seize to the thread part of sensor (5).

 *NOTE: Anti-seize has been applied to new sensor (5).*

11. Install sensor (5) to aftertreatment device (14).

 : 22 mm

 : 50 N·m

12. Install the connector (9) side of sensor (5) with socket bolts (13) (2 used).

 : 6 mm

 : 8.5 N·m

13. Install harnesses (6, 10, 12) with clips (4) (6 used).

14. Connect connectors (9) (2 used) and connector (15). Install connector (15) with bolt, washer (11).

 : 17 mm

 : 50 N·m

15. Connect hoses (3) (2 used). Install hoses (3) (2 used) with clips (2) (2 used) and bolts, washers (1) (2 used).

 : 17 mm

 : 50 N·m

SECTION 3 UPPERSTRUCTURE

Group 15 DEF Tank

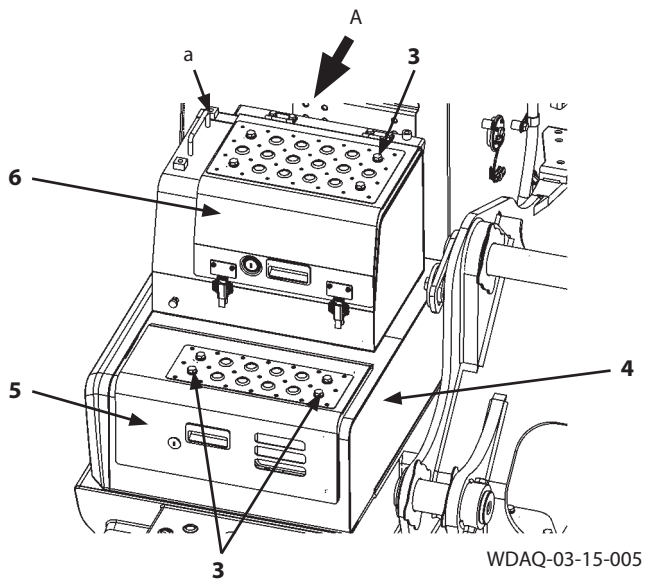

View A

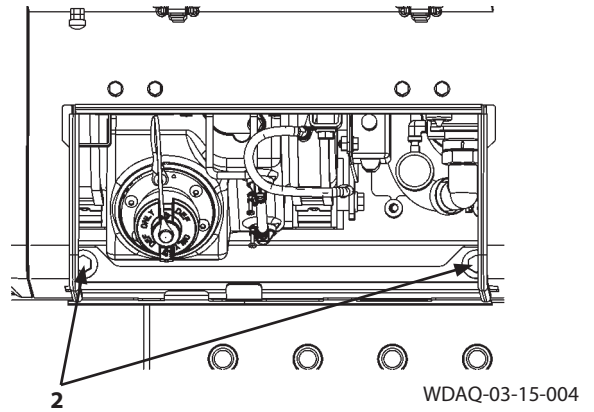

a- Eyebolt Mounting Hole

10. Remove bolts, washers (2) (2 used).

 : 17 mm

11. Close the covers (5, 6). Lock the key.

12. Remove bolts, washers (3) (3 used).

 : 17 mm

⚠ CAUTION: The tool box (4) assembly weight: 53 kg

13. Install the eyebolts (M10, Pitch 1.5 mm) (4 used) to eyebolt mounting hole (a) (1 place) and bolt, washer (3) mounting holes (3 places). Attach nylon slings onto the eyebolts. Hoist and remove the tool box (4) assembly.

SECTION 3 UPPERSTRUCTURE

Group 15 DEF Tank

Detail B

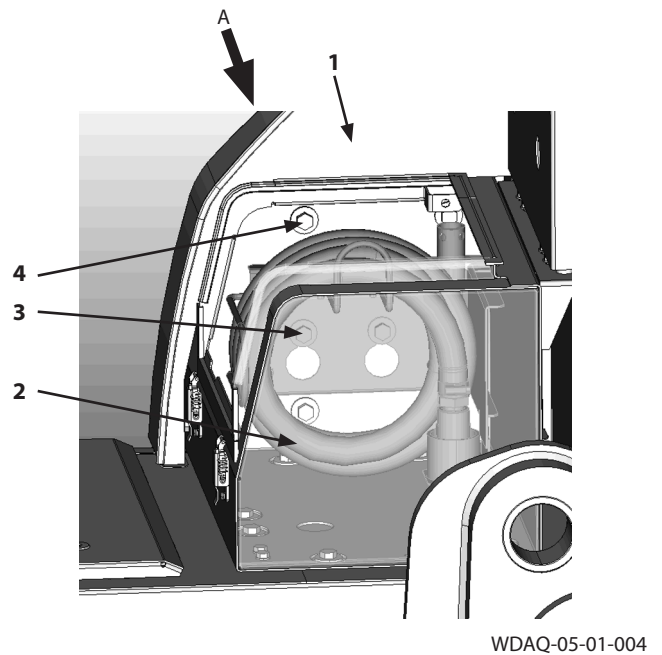
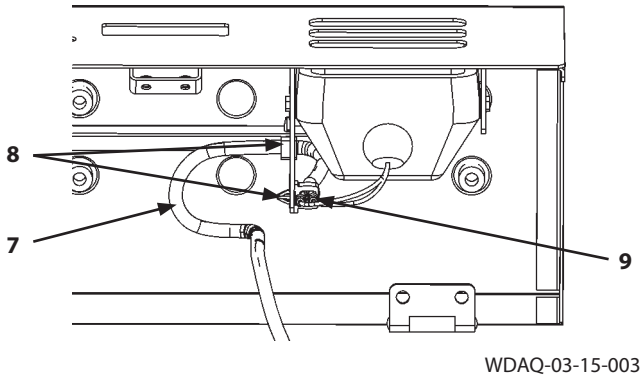

20. Connect connectors (9) (2 used). Install harness (7) with clips (8) (2 used).

21. Install cover (1) with bolts, washers (4) (4 used).

 : 17 mm

 : 50 N·m

22. Install the hose (2) assembly with bolts, washers (3) (2 used).

 : 17 mm

 : 50 N·m

23. Remove the eyebolts (4 used).

24. Install bolts, washers (10) (3 used).

 : 17 mm

 : 50 N·m

View A

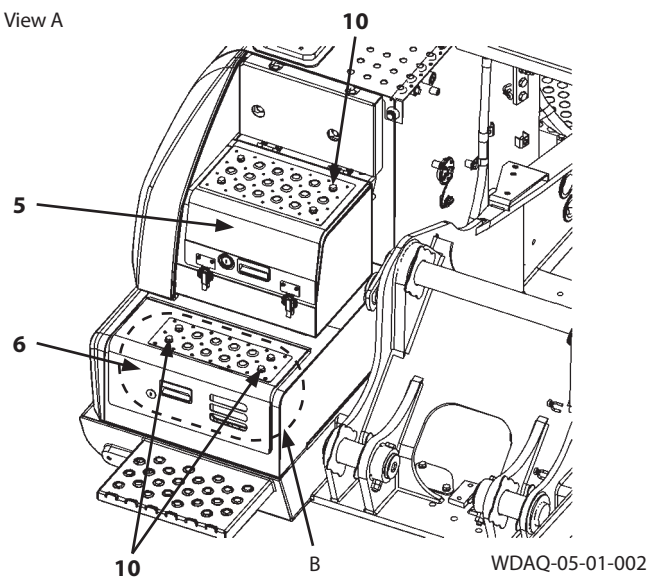

25. Close covers (5, 6).

MEMO

SECTION 4 UNDERCARRIAGE

Group 1 Swing Bearing

Disassembly of Swing Bearing

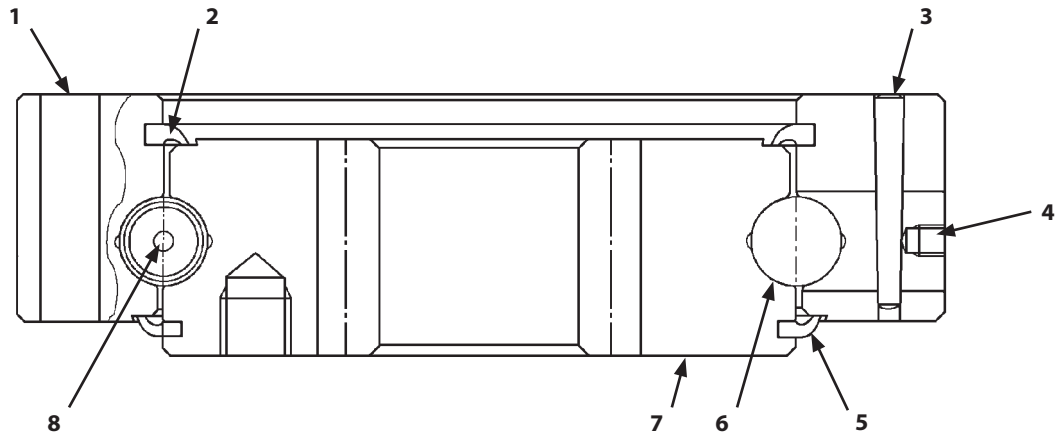

W178-02-11-193

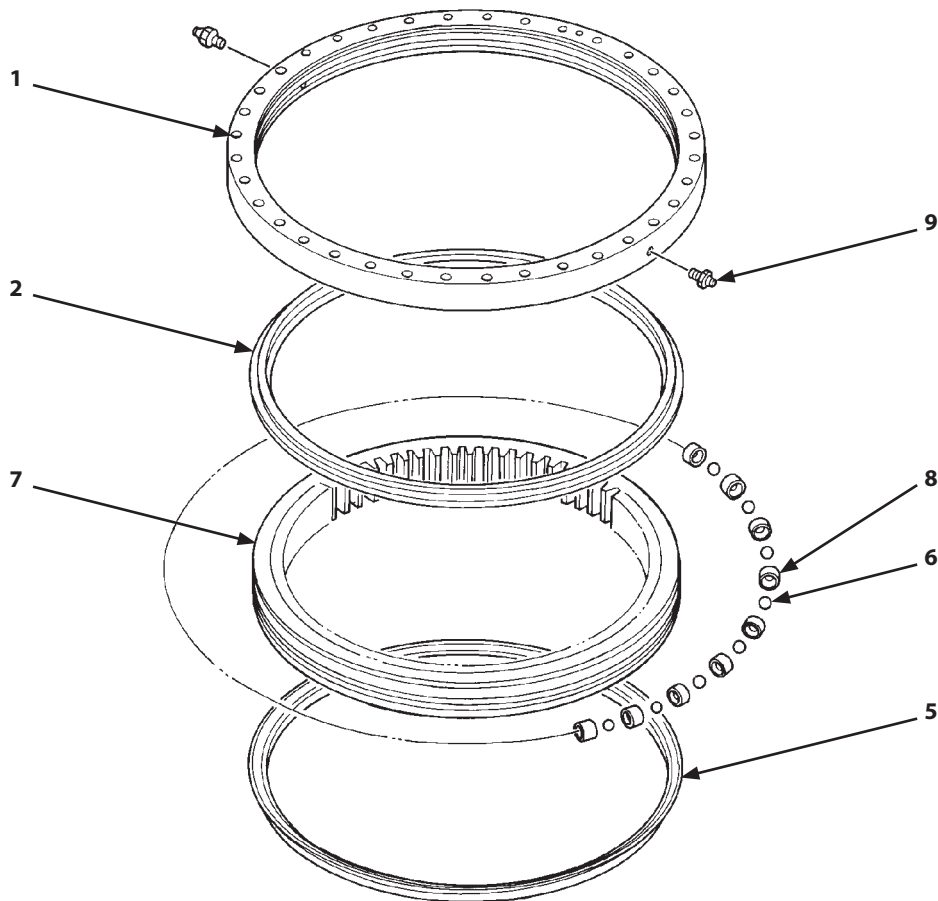

W178-02-11-194

- 1- Outer Race
- 2- Seal
- 3- Pin
- 4- Plug

- 5- Seal
- 6- Ball (121 Used)
- 7- Inner Race
- 8- Support (121 Used)

- 9- Grease Fitting (2 Used)

SECTION 4 UNDERCARRIAGE

Group 2 Travel Device

Disassembly of Travel Device

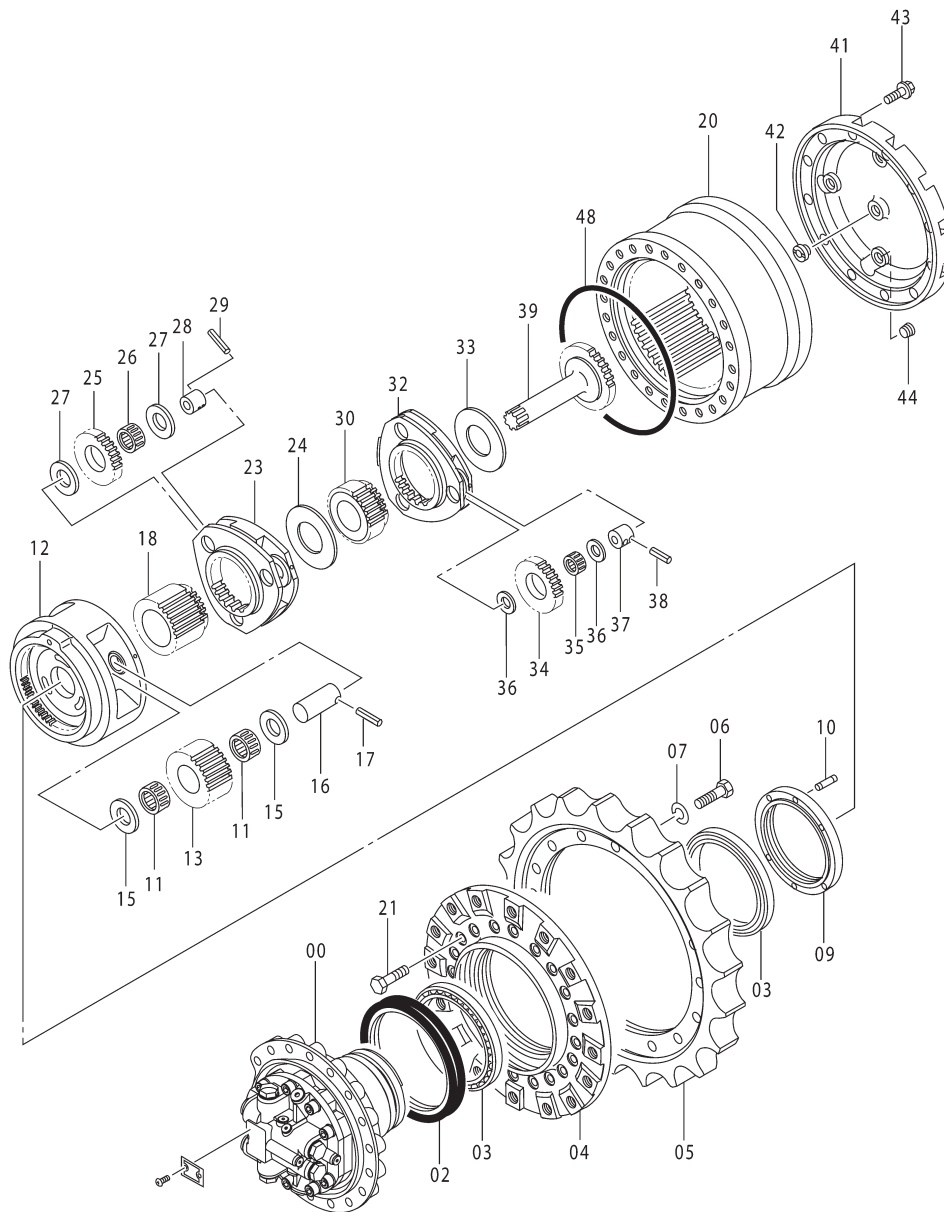

WDBE-04-02-004

- | | | | |
|-----------------------------|-----------------------------|-----------------------------|----------------------------|
| 00- Travel Motor | 12- Third Stage Carrier | 25- Planetary Gear (3 Used) | 36- Thrust Plate (6 Used) |
| 02- Floating Seal | 13- Planetary Gear (3 Used) | 26- Needle Bearing (3 Used) | 37- Pin (3 Used) |
| 03- Roller Bearing (2 Used) | 15- Thrust Plate (6 Used) | 27- Thrust Plate (6 Used) | 38- Spring Pin (3 Used) |
| 04- Drum | 16- Pin (3 Used) | 28- Pin (3 Used) | 39- Shaft |
| 05- Sprocket | 17- Spring Pin (3 Used) | 29- Spring Pin (3 Used) | 41- Cover |
| 06- Bolt (18 Used) | 18- Sun Gear | 30- Sun Gear | 42- Stopper |
| 07- Spring Washer (18 Used) | 20- Ring Gear | 32- First Stage Carrier | 43- Bolt, Washer (16 Used) |
| 09- Bearing Nut | 21- Bolt (20 Used) | 33- Spacer | 44- Plug (3 Used) |
| 10- Knock Pin | 23- Second Stage Carrier | 34- Planetary Gear (3 Used) | 48- O-Ring |
| 11- Needle Bearing (6 Used) | 24- Spacer | 35- Needle Bearing (3 Used) | |

SECTION 4 UNDERCARRIAGE

Group 2 Travel Device

40. Install spring pin (38) to first stage carrier (32) with the slit (b) side facing to the cover (41) side.

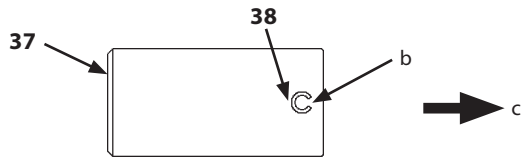

W178-02-11-210

a - Slit

c - Cover (41) Side

41. Install other planetary gears (34) (2 used) to first stage carrier (32) in the same way as steps 37 to 40.
42. Install the first stage carrier (32) assembly to ring gear (20).
43. Insert the spline side of shaft (39) into the center of sun gear (30). Slowly turn sprocket (05) by hand. Engage shaft (39) with travel motor (00) and planetary gear (34). Install them.
44. Add gear oil (API GL4 SAE#90) through the ring gear (20) side.

 **NOTE:** Amount of oil: 6.8 L

45. Clean the mating surfaces of ring gear (20) and cover (41). Apply THREEBOND #1215 or LOCTITE #5020. Install cover (41) to ring gear (20) with bolts, washers (43) (16 used).

 : 19 mm

 : 110 N·m

46. Install a seal tape onto plugs (44) (3 used). Install plugs (44) (3 used) to cover (41).

 : 10 mm

 : 50 N·m

SECTION 4 UNDERCARRIAGE

Group 2 Travel Device

Disassembly of Brake Valve

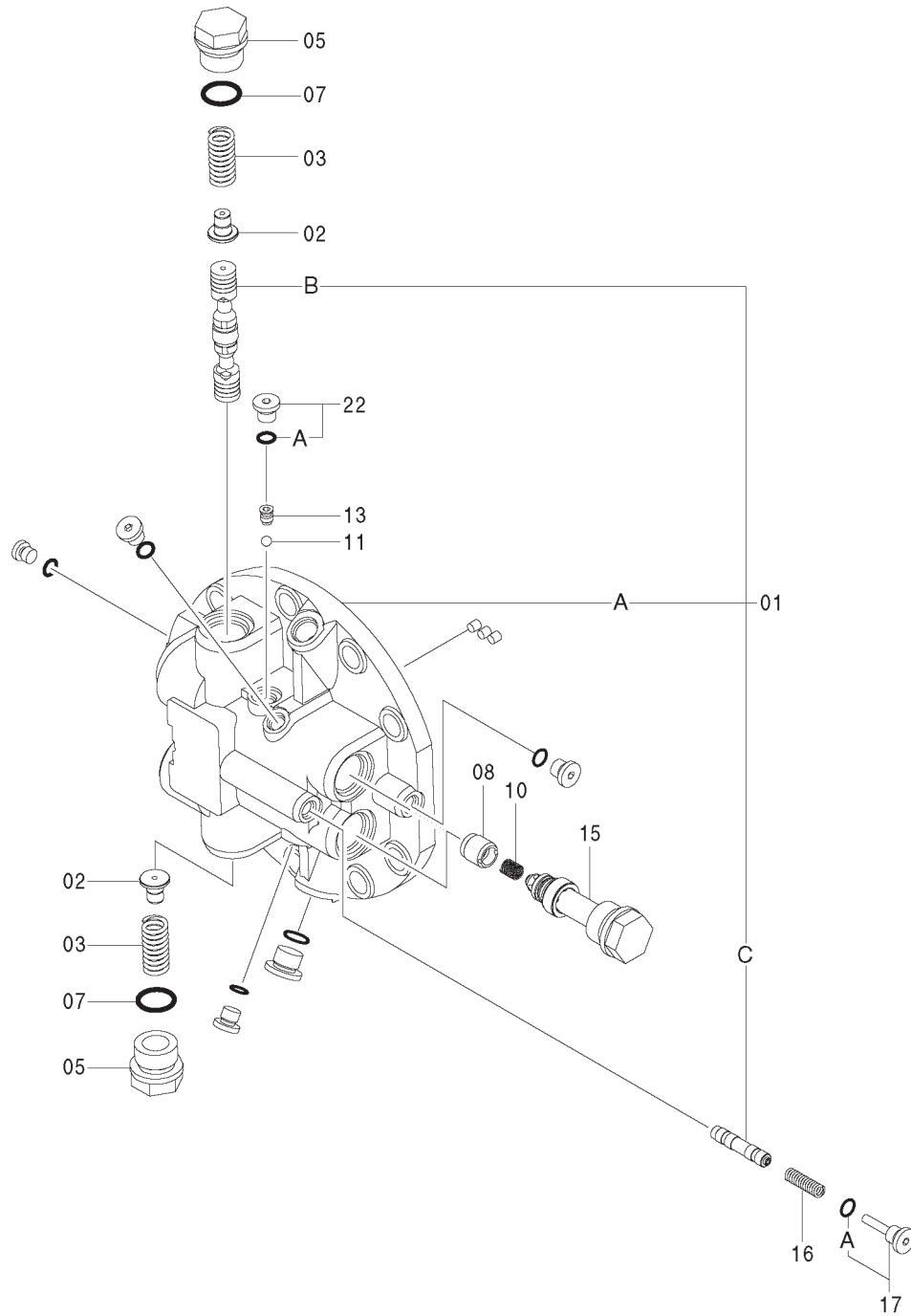

WDAA-04-02-009

01A- Casing

01B- Spool

01C- Spool

02- Stopper (2 Used)

03- Spring (2 Used)

05- Plug (2 Used)

07- O-Ring (2 Used)

08- Poppet (2 Used)

10- Spring (2 Used)

11- Ball

13- Seat

15- Relief Valve (2 Used)

16- Spring

17- Plug

17A- O-Ring

22- Plug

22A- O-Ring

SECTION 4 UNDERCARRIAGE

Group 3 Center Joint

Disassembly of Center Joint

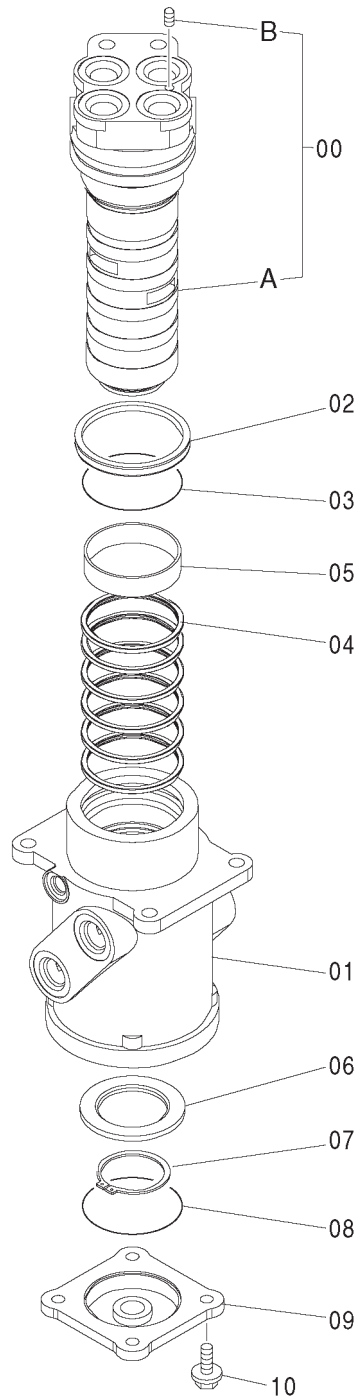

WDAA-04-03-003

00A- Spindle
00B- Plug with Ball
01- Body
02- Dust Seal

03- O-Ring
04- Oil Seal (6 Used)
05- Bushing

06- Ring
07- Retaining Ring
08- O-Ring

09- Cover
10- Bolt, Washer (4 Used)

SECTION 4 UNDERCARRIAGE

Group 4 Track Adjuster

Disassembly of Front Idler

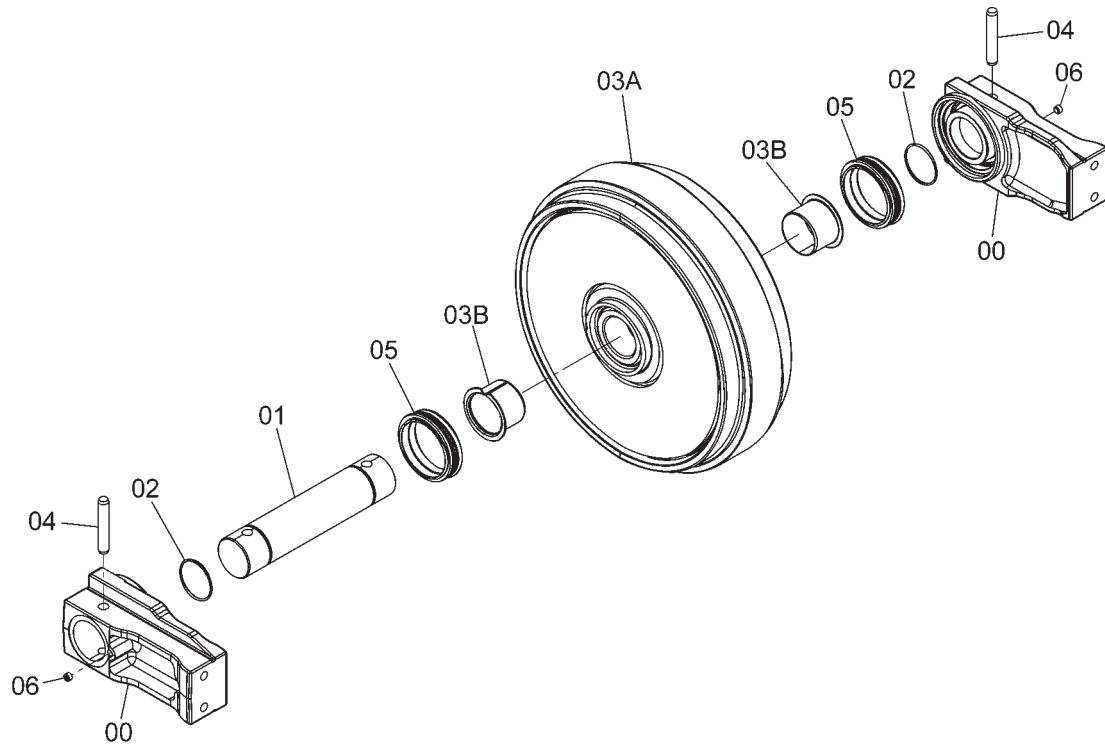

WDCD-04-04-006

00- Bearing (2 Used)
01- Axle

02- O-Ring (2 Used)
03A- Idler

03B- Bushing (2 Used)
04- Pin (2 Used)

05- Floating Seal (2 Used)
06- Plug (2 Used)

SECTION 4 UNDERCARRIAGE

Group 4 Track Adjuster

Assembly of Track Adjuster

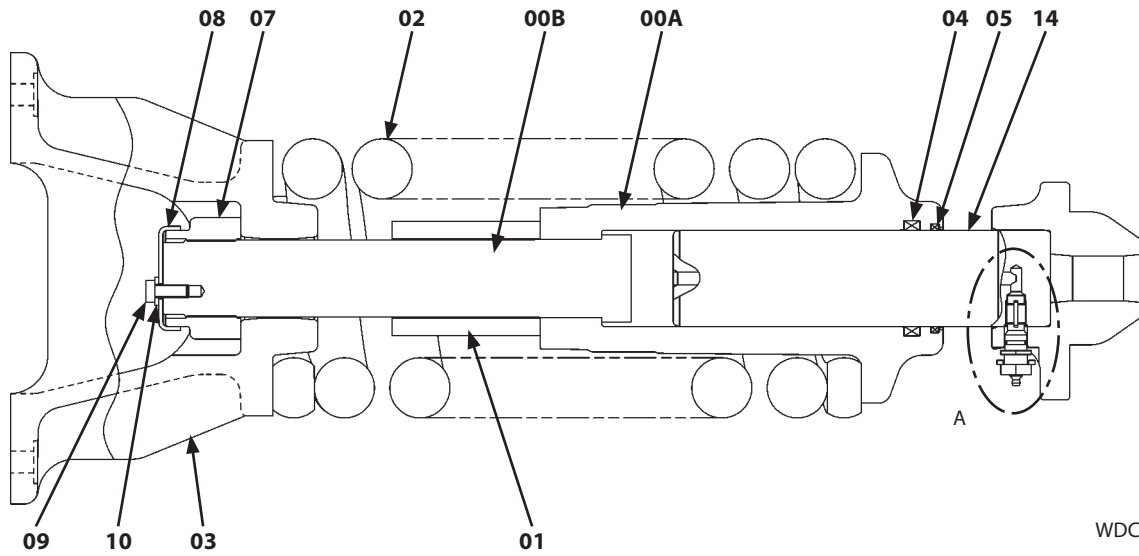

WDCD-04-04-008

Detail A

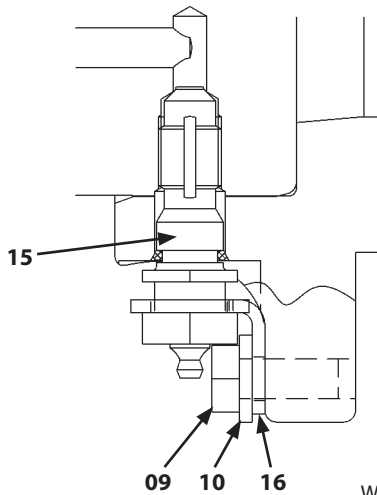

WDC150-04-04-003

00A- Cylinder
00B- Rod
01- Spacer
02- Spring

03- Yoke
04- Seal
05- Dust Seal
07- Nut

08- Bracket
09- Bolt (2 Used)
10- Washer (2 Used)
14- Piston

15- Valve
16- Bracket

SECTION 4 UNDERCARRIAGE

Group 6 Upper and Lower Rollers

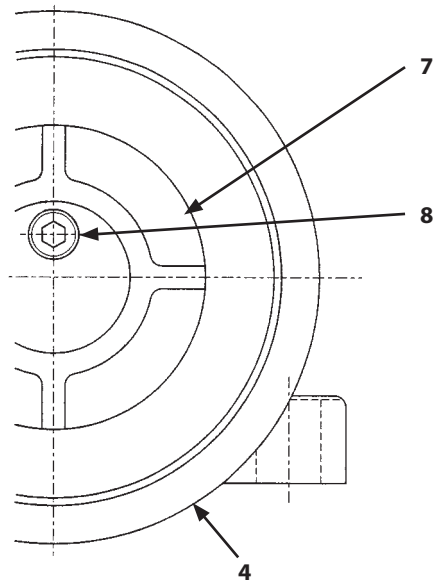

W158-03-06-001

6. Lower the machine.

IMPORTANT: Upper roller (4) cannot be disassembled. Replace it as an assembly.

7. Remove plug (8).

 : 6 mm

8. Add engine oil (API CD class SAE #30) through the plug (8) hole of cover (7).

 **NOTE:** Amount of oil: 65 mL

9. Apply THREEBOND #2353 onto plug (8).

10. Tighten plug (8).

 : 6 mm

 : 20 N·m

SECTION 4 UNDERCARRIAGE

Group 6 Upper and Lower Rollers

Assembly of Lower Roller

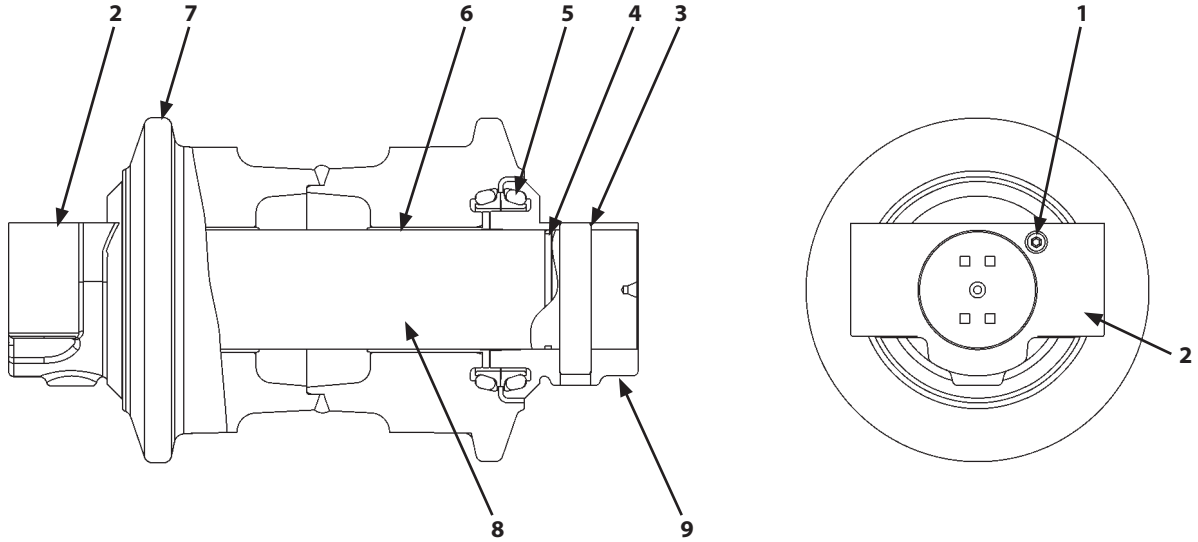

WDDK-04-05-005

- | | | |
|-----------------|---------------------------|-----------|
| 1- Plug | 4- O-Ring (2 Used) | 7- Roller |
| 2- Collar | 5- Floating Seal (2 Used) | 8- Axle |
| 3- Pin (2 Used) | 6- Bushing (2 Used) | 9- Collar |

SECTION 4 UNDERCARRIAGE

Group 7 Track

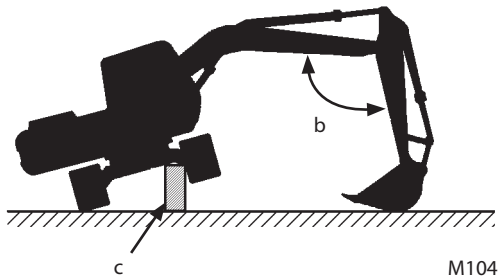

M104-07-067

- b - 90 to 110°
- c - Stand

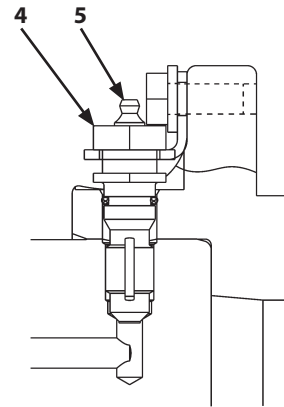

WDCD-04-06-001

9. Set the angle between the boom and arm to 90 to 110 degrees. Lower the boom with the round bottom of the bucket contacting with the ground. Raise the track frame off the ground. At this time, place stands (c) under the track frame and support the machine.

10. Tighten valve (4). Apply grease through grease fitting (5) and adjust the track tension.

 : 24 mm

 : 90 N·m

 **NOTE:** Track sag specification (a): 285 to 320 mm

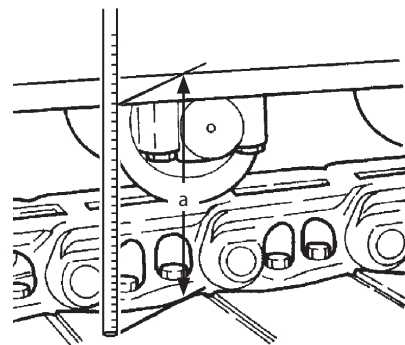

Wxxx-03-07-001

a - Track Sag Specification

SECTION 5 FRONT ATTACHMENT

Group 1 Front Attachment

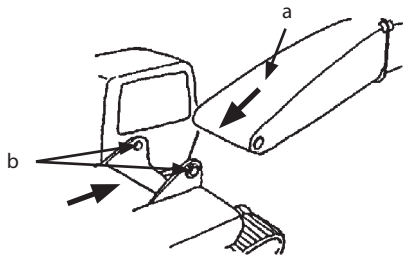

W178-02-11-282

- a- Front Attachment Assembly b- Boom Foot Pin Mounting Hole

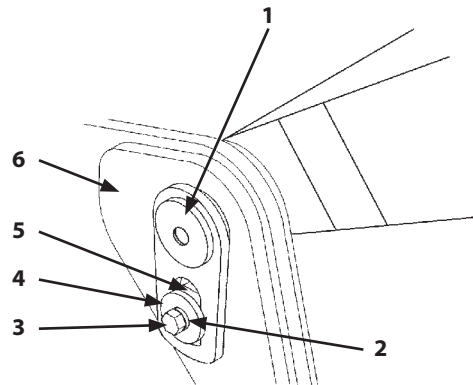

W178-02-11-280

Installation

CAUTION: Front attachment assembly (a) weight: 2630 kg

IMPORTANT: Use one or more thrust plates respectively at the right and left sides.

1. Apply grease to the boom foot pin mounting hole (b) of main frame (6).
2. Attach wire ropes onto front attachment assembly (a). Hoist front attachment assembly (a). Fit the boom foot to the boom mounting hole on the frame. Install the thrust plates to right and left sides and adjust total clearance of right and left within 1 mm (0.039 in). (Adjust the position by using the lifting ropes for the front attachment.)

NOTE: Thrust plate thickness: 2 mm, 2.5 mm, 3 mm

CAUTION: Boom foot pin (1) weight: 33 kg

CAUTION: Metal fragments may fly off when a hammer is used. Wear necessary protection, such as goggles, hard hats, etc. in order to prevent personal injury.

3. Install boom foot pin (1) by using a hammer. Install block (5), plate (4), washer (2), and bolt (3).

 : 27 mm

 : 400 N·m

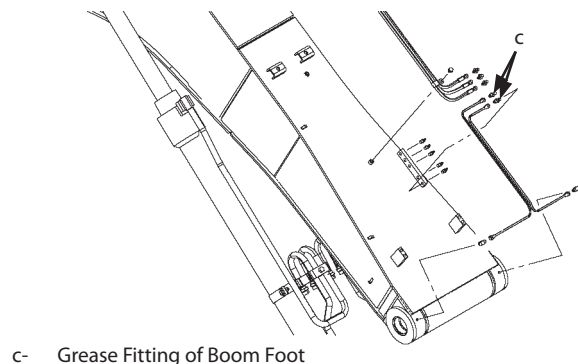

c- Grease Fitting of Boom Foot

WDBL-05-01-003

4. Apply grease to grease fittings (c) (2 places) of the boom foot.

SECTION 5 FRONT ATTACHMENT

Group 2 Cylinder

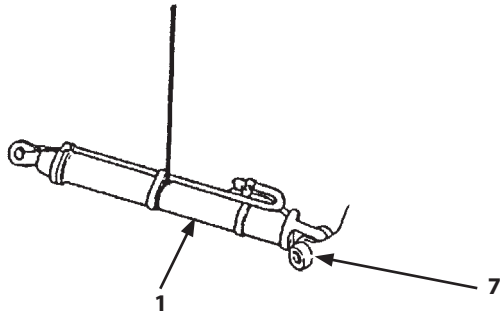

W105-04-02-040

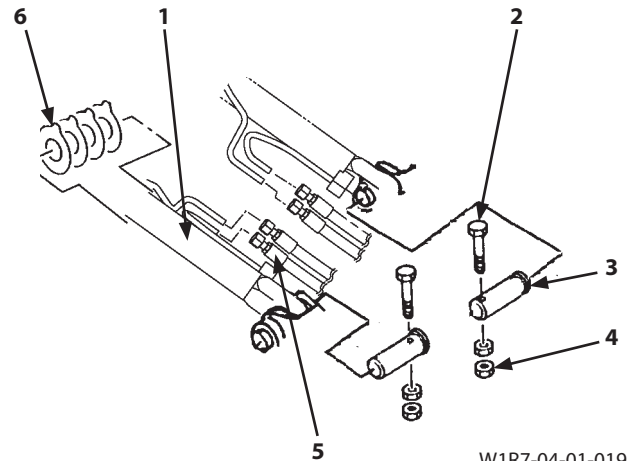

W1R7-04-01-019

Installation

CAUTION: Boom cylinder (1) weight: 170 kg

1. Attach nylon slings onto boom cylinder (1). Hoist boom cylinder (1). Fit the hole at the cylinder bottom side to the mounting hole on main frame (7).

IMPORTANT: Use one or more thrust plates (6) respectively at the right and left sides.

2. Fit thrust plates (6) to the holes of the right and left sides at cylinder bottom side. Adjust the clearance between the cylinder bottom side and main frame (7) within 1 mm. At this time, Fit thrust plate (6) (thickness: 1mm) to the opposite side of the cab and adjust the clearance at the cab side.

NOTE: Thrust plate (6) thickness: 1 mm, 2 mm

CAUTION: Metal fragments may fly off when a hammer is used. Wear necessary protection, such as goggles, hard hats, etc. in order to prevent personal injury.

3. Install pin (3) by using a hammer. Install bolt (2) to pin (3) with nuts (4) (2 used).

 : 24 mm

 : 140 N·m

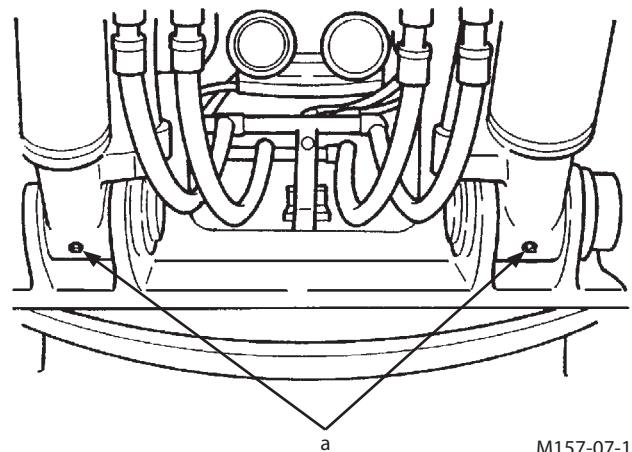

M157-07-156

a- Grease Fitting at Cylinder Bottom Side

4. Install other boom cylinder (1) to main frame (7) in the same way as step 1 to step 3.
5. Apply grease to grease fittings (a) at the cylinder bottom side.
6. Connect hoses (5) (4 used) to boom cylinders (1) (2 used).

 : 36 mm

 : 180 N·m

SECTION 5 FRONT ATTACHMENT

Group 2 Cylinder

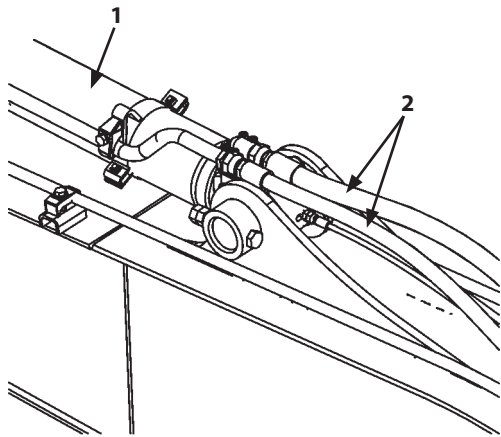

WDAQ-05-02-007

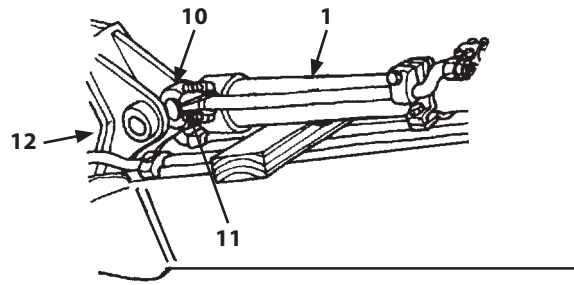

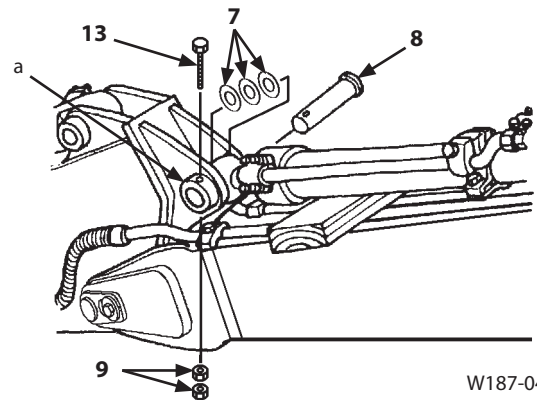

W187-04-02-010



W187-04-02-006

8. Connect hoses (2) (2 used) to arm cylinder (1).

 : 36 mm

 : 180 N·m

IMPORTANT: Check the hydraulic oil level. Start the engine and check for any oil leaks.

a- Stopper Part

9. Remove wires (11) from rod (10) of arm cylinder (1). Start the engine. Operate the arm control lever and fit the hole at the cylinder rod side to the mounting holes of arm (12).

IMPORTANT: Use one or more thrust plates (7) respectively at the right and left sides.

10. Fit the holes of thrust plates (7) and the right and left sides at the cylinder rod side. Adjust total clearance of right and left between arm cylinder (1) and arm (12) within 1 mm.

 **NOTE:** Thrust plate (7) thickness: 1 mm, 2 mm

 **CAUTION:** Metal fragments may fly off when a hammer is used. Wear necessary protection, such as goggles, hard hats, etc. in order to prevent personal injury.

11. Install pin (8) by using a hammer.
12. Install bolt (13) to pin (8) and stopper part (a) of arm (12) with nuts (9) (2 used).

 : 30 mm

 : 280 N·m

SECTION 5 FRONT ATTACHMENT

Group 2 Cylinder

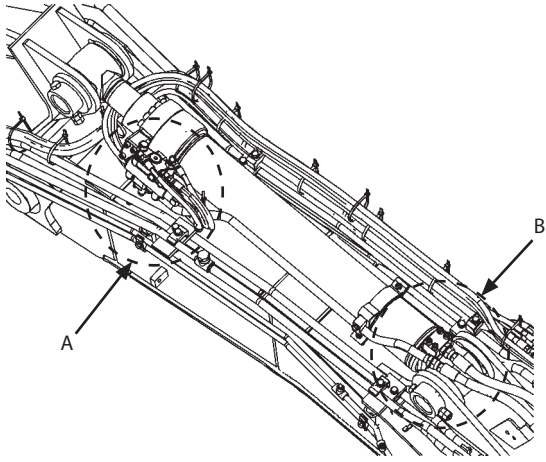

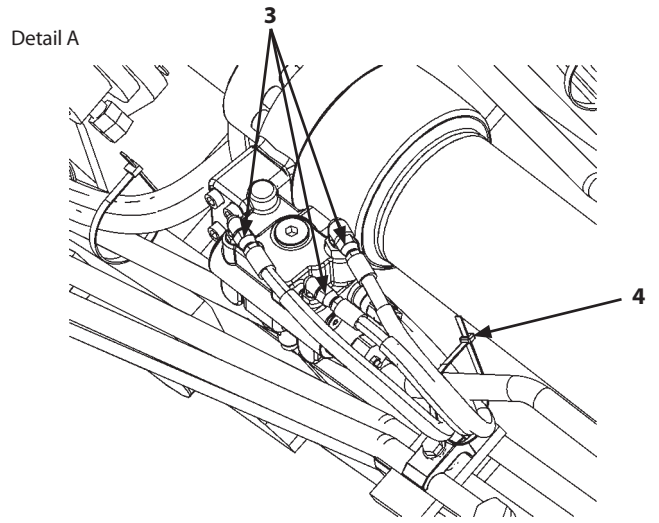

WDBR-05-02-004



WDBR-05-02-005

5. Connect hoses (3) (3 used).

 : 19 mm

 : 30 N·m

6. Connect hoses (1) (2 used).

 : 36 mm

 : 180 N·m

7. Install clip band (4).

Detail B

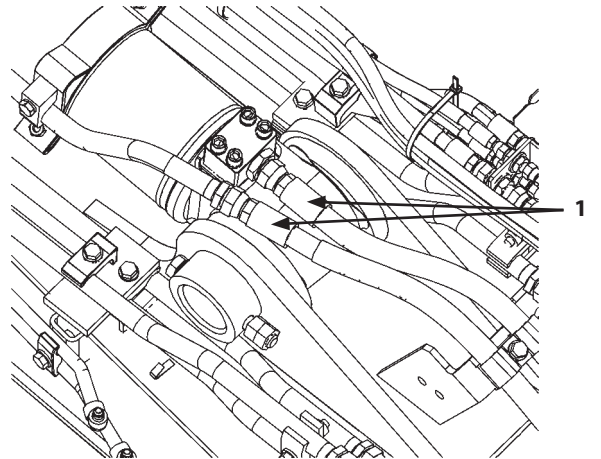

WDBR-05-02-006

SECTION 5 FRONT ATTACHMENT

Group 2 Cylinder

Arm Cylinder

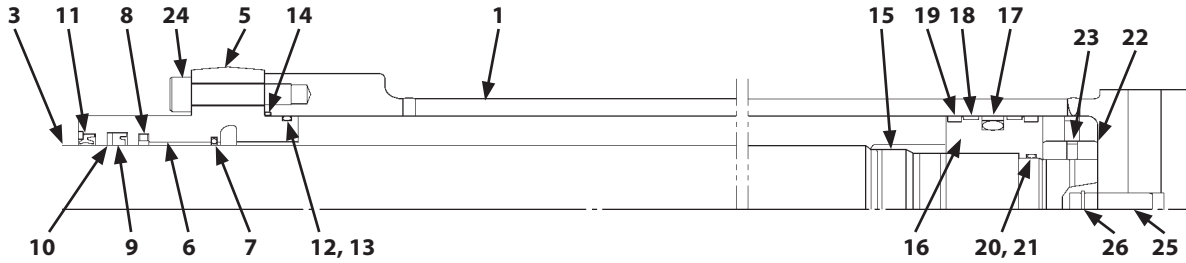

W1V1-04-02-004

- | | | | |
|-------------------|-----------------|------------------------|---------------------------|
| 1- Cylinder Tube | 9- U-Ring | 15- Cushion Ring | 21- Backup Ring (2 Used) |
| 3- Cylinder Rod | 10- Backup Ring | 16- Piston | 22- Nut |
| 5- Cylinder Head | 11- Dust Seal | 17- Seal Ring | 23- Set Screw (2 Used) |
| 6- Bushing | 12- O-Ring | 18- Wear Ring (2 Used) | 24- Socket Bolt (12 Used) |
| 7- Retaining Ring | 13- Backup Ring | 19- Wear Ring (2 Used) | 25- Plunger |
| 8- Seal | 14- O-Ring | 20- O-Ring | 26- Ring |

SECTION 5 FRONT ATTACHMENT

Group 2 Cylinder

CAUTION: The cylinder rod (3) assembly weight: 100 kg

4. Remove the cylinder rod (3) assembly from cylinder tube (1). Secure it to the special tool (ST 5908).

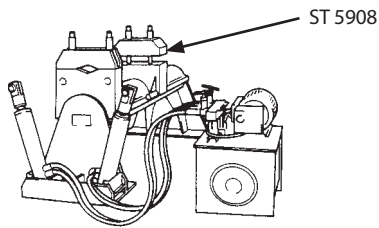

W158-04-02-022

6. Remove nut (22) by using special tool (ST 5908) and special tool (a).

Special Tool (a):

ST 3264 (Wrench Size: 100 mm)

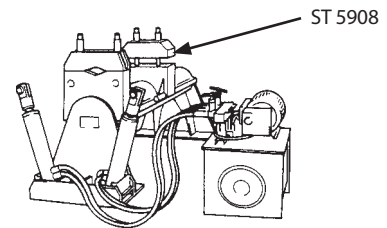

W158-04-02-022

5. Cut away the crimped part by using a hand drill. Remove set screws (23) (2 used).

 : 4 mm

 *NOTE:* Set screws (23) (2 used) have been crimped by using a punch at two places after installing them.

 *NOTE:* LOCTITE #243 or equivalent has been applied to set screw (23).

7. Remove piston (16) by using special tool (ST 5908) and special tool (b).

Special Tool (b):

ST 3353 (Pitch 110 mm)

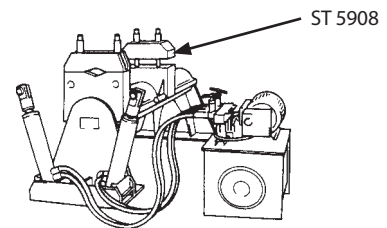

W158-04-02-022

SECTION 5 FRONT ATTACHMENT

Group 3 Hose Rupture Valve

Removal and Installation of Hose Rupture Valve for Boom Cylinder

IMPORTANT: The hoses and pipes contain hydraulic oil. When removing the hoses and pipes, receive oil with a container in order to avoid spilling oil.

IMPORTANT: Cap the open ends in case the hoses and pipes have been disconnected. In addition, attach identification tags onto the connectors, hoses, and pipes for assembling. If the clips which secure the hoses have been removed, install the clips after connecting the hoses.

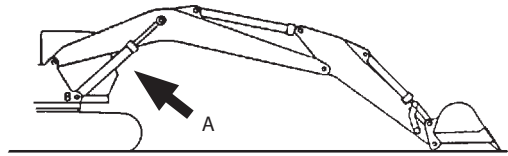

W105-04-02-001

View A

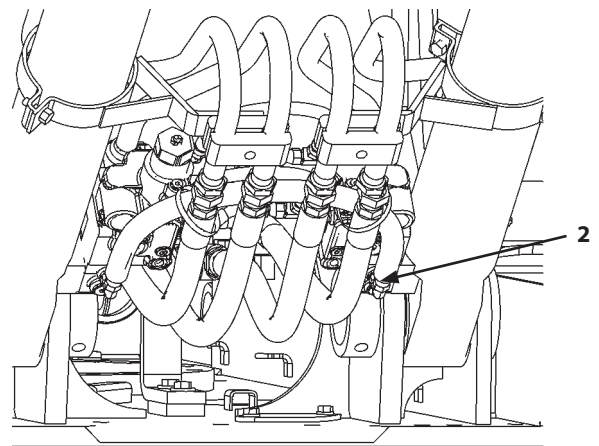

WDBR-05-02-002

Removal

1. Park the machine on a solid and level surface. Fully retract the arm cylinder and the bucket cylinder and lower the boom. Place the arm end on the ground.

CAUTION: Release any pressure in the hydraulic oil tank. (Refer to W1-5-1.)

CAUTION: Release any pressure in the hydraulic circuit. (Refer to W1-5-1.)

2. Disconnect hoses (2) (5 used) from hose rupture valve (5).

 : 19 mm

3. Remove socket bolts (7, 8) (2 used for each). Disconnect pipe (9).

 : 8 mm

4. Remove socket bolts (4) (4 used). Remove O-ring (6) and hose rupture valve (5) from boom cylinder (11). Remove O-ring (10) from pipe (9).

 : 8 mm

5. Remove the adapters from hose rupture valve (5) if necessary.

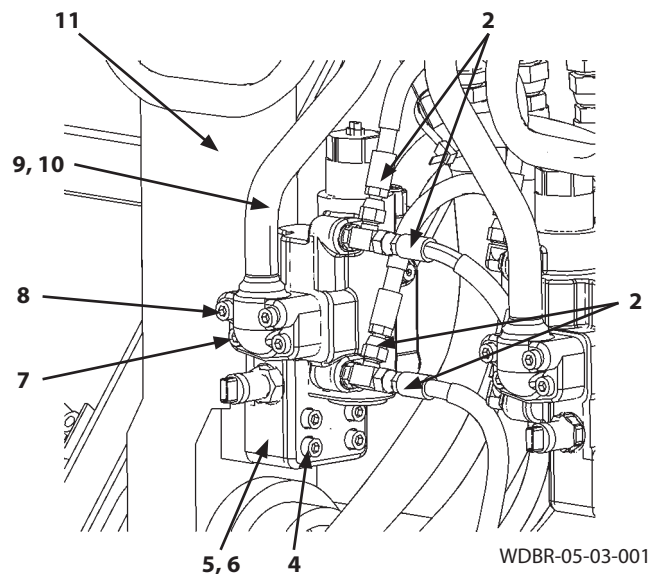



WDBR-05-03-001

SECTION 5 FRONT ATTACHMENT

Group 3 Hose Rupture Valve

6. Loosen the hose rupture valve (2) side of hose (1) by one to two turns.
7. Start the engine. Slowly operate the positioning lever to the retract direction, drain hydraulic oil, and bleed air from hose rupture valve (2).
8. Stop the engine. Tighten hose (1).

 : 19 mm

 : 30 N·m

IMPORTANT: Check the hydraulic oil level. Start the engine and check for any oil leaks.

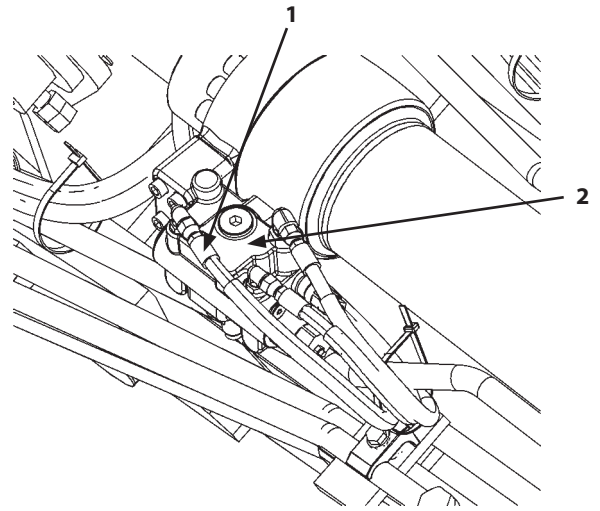

WDBR-05-02-005

CLICK HERE TO **DOWNLOAD** THE COMPLETE MANUAL

- Thank you very much for reading the preview of the manual.
- You can download the complete manual from: www.heydownloads.com by clicking the link below



- Please note: If there is no response to CLICKING the link, please download this PDF first and then click on it.

CLICK HERE TO **DOWNLOAD** THE COMPLETE MANUAL