

PART NO. WCJB-E-00

**HITACHI**

# Workshop Manual

# ZX 210W-3 220W-3 Hydraulic Excavator

ZX210W-3 · 220W-3 HYDRAULIC EXCAVATOR WORKSHOP MANUAL

 **Hitachi Construction Machinery**

URL:<http://www.hitachi-c-m.com>

PRINTED IN JAPAN (K) 2007.08

Service Manual consists of the following separate Part No.  
Technical Manual (Operational Principle) : Vol. No.TOCJB-E  
Technical Manual (Troubleshooting) : Vol. No.TTCJB-E  
Workshop Manual : Vol. No.WCJB-E

CLICK HERE TO **DOWNLOAD** THE COMPLETE MANUAL

- Thank you very much for reading the preview of the manual.
- You can download the complete manual from: [www.heydownloads.com](http://www.heydownloads.com) by clicking the link below



- Please note: If there is no response to CLICKING the link, please download this PDF first and then click on it.

CLICK HERE TO **DOWNLOAD** THE COMPLETE MANUAL

## SAFETY

---

### OPERATE ONLY FROM OPERATOR'S SEAT

- Inappropriate engine starting procedures may cause the machine to runaway, possibly resulting in serious injury or death.
  - Start the engine only when seated in the operator's seat.
  - NEVER start the engine while standing on the track or on ground.
  - Do not start engine by shorting across starter terminals.
  - Before starting the engine, confirm that all control levers are in neutral.
  - Before starting the engine, confirm the safety around the machine and sound the horn to alert bystanders.

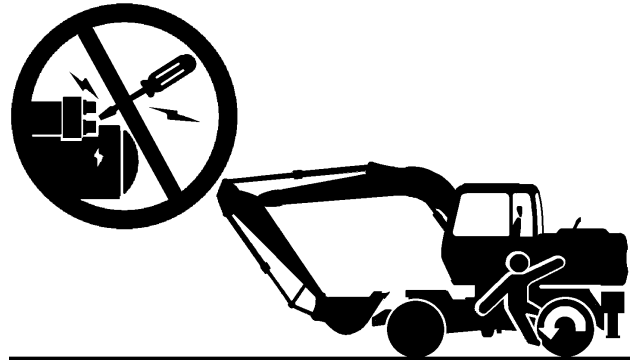

SA-084

012-E01B-0431

---

### JUMP STARTING

- Battery gas can explode, resulting in serious injury.
  - If the engine must be jump started, be sure to follow the instructions shown in the "OPERATING THE ENGINE" chapter in the operator's manual.
  - The operator must be in the operator's seat so that the machine will be under control when the engine starts. Jump starting is a two-person operation.
  - Never use a frozen battery.
  - Failure to follow correct jump starting procedures could result in a battery explosion or a runaway machine.

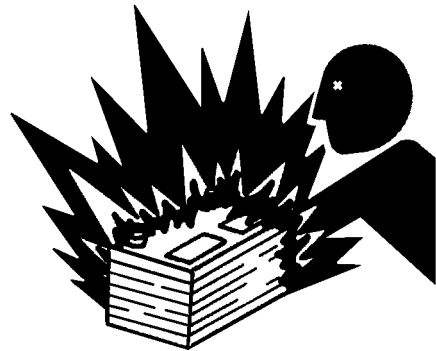

SA-032

S013-E01A-0032

---

### KEEP RIDERS OFF MACHINE

- Riders on machine are subject to injury such as being struck by foreign objects and being thrown off the machine.
  - Only the operator should be on the machine. Keep riders off.
  - Riders also obstruct the operator's view, resulting in the machine being operated in an unsafe manner.



014-E01B-0427

SA-091

## SAFETY

### PROTECT AGAINST FLYING DEBRIS

- If flying debris hit eyes or any other part of the body, serious injury may result.
- Guard against injury from flying pieces of metal or debris; wear goggles or safety glasses.
- Keep bystanders away from the working area before striking any object.

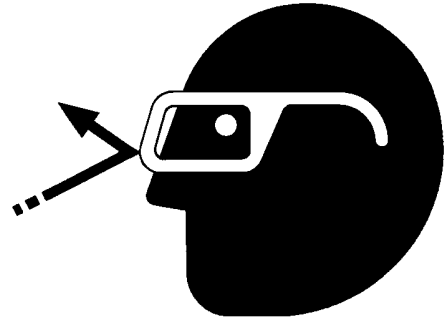

031-E01A-0432

SA-432

### PARK MACHINE SAFELY

To avoid accidents:

- Park machine on a firm, level surface.
- Lower bucket to the ground.
- Place FNR switch in neutral, and put the brake switch in the P (parking brake) position.
- Turn auto-idle switch OFF.
- Run engine at slow idle speed without load for 5 minutes.
- Turn key switch to OFF to stop engine.
- Remove the key from the key switch.
- Pull the pilot control shut-off lever to the LOCK position.
- Close windows, roof vent, and cab door.
- Lock all access doors and compartments.

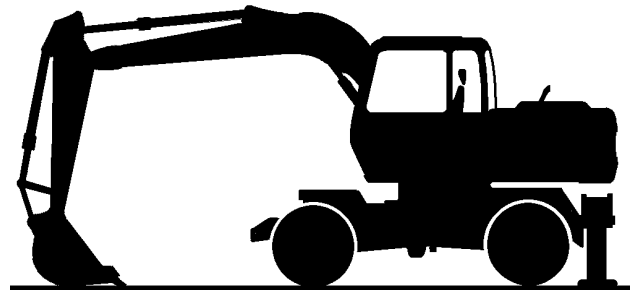

SA-093

### HANDLE FLUIDS SAFELY—AVOID FIRES

- Handle fuel with care; it is highly flammable. If fuel ignites, an explosion and/or a fire may occur, possibly resulting in serious injury or death.
- Do not refuel the machine while smoking or when near open flame or sparks.
- Always stop the engine before refueling the machine.
- Fill the fuel tank outdoors.
- All fuels, most lubricants, and some coolants are flammable.
- Store flammable fluids well away from fire hazards.
- Do not incinerate or puncture pressurized containers.
- Do not store oily rags; they can ignite and burn spontaneously.
- Securely tighten the fuel and oil filler cap.



SA-018



034-E01A-0496

SA-019

## SAFETY

### BEWARE OF ASBESTOS DUST

- Take care not to inhale dust produced in the work site. Inhalation of asbestos fibers may be the cause of lung cancer.
- Depending on the work site conditions, the risk of inhaling asbestos fiber may exist. Spray water to prevent asbestos from becoming airborne. Do not use compressed air.
- When operating the machine in a work site where asbestos might be present, be sure to operate the machine from the upwind side and wear a mask rated to prevent the inhalation of asbestos.
- Keep bystanders out of the work site during operation.
- Asbestos might be present in imitation parts. Use only genuine Hitachi Parts.

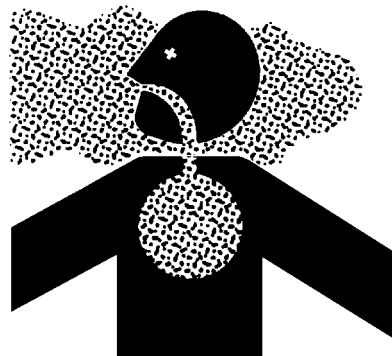

SA-029

### PREVENT BATTERY EXPLOSIONS

- Battery gas can explode.
  - Keep sparks, lighted matches, and flame away from the top of battery.
  - Never check battery charge by placing a metal object across the posts. Use a voltmeter or hydrometer.
  - Do not charge a frozen battery; it may explode. Warm the battery to 16°C ( 60° F ) first.
  - Do not continue to use or charge the battery when electrolyte level is lower than specified. Explosion of the battery may result.
  - Loose terminals may produce sparks. Securely tighten all terminals.
- Battery electrolyte is poisonous. If the battery should explode, battery electrolyte may be splashed into eyes, possibly resulting in blindness.
  - Be sure to wear eye protection when checking electrolyte specific gravity.

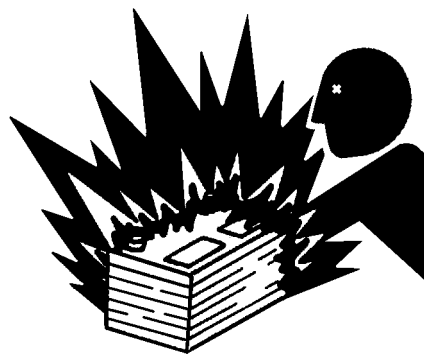

SA-032

512-E01B-0032

### SERVICE AIR CONDITIONING SYSTEM SAFELY

- If spilled onto skin, refrigerant may cause a cold contact burn.
  - Refer to the instructions described on the container for proper use when handling the refrigerant.
  - Use a recovery and recycling system to avoid leaking refrigerant into the atmosphere.
  - Never touch the refrigerant.



513-E01A-0405

SA-405

## GENERAL / Precautions for Disassembling and Assembling

---

- Bleeding Air from Hydraulic Circuit
  - After refilling hydraulic oil, start the engine. While operating each cylinder, swing motor and travel motor evenly, operate the machine under light loads for 10 to 15 minutes. Slowly start each operation (never fully stroke the cylinders during initial operation stage). As the pilot oil circuit has an air bleed device, air trapped in the pilot oil circuit will be bled while performing the above operation for approx. 5 minutes.
  - Reposition the front attachment to check hydraulic oil level.
  - Stop the engine. Recheck hydraulic oil level. Replenish oil as necessary.

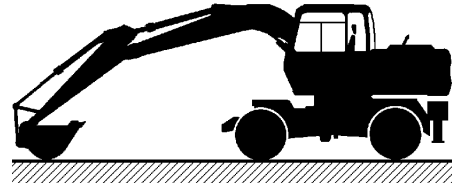

WCJB-01-04-001

# GENERAL / Tightening

## Service Recommendations for Split Flange

- IMPORTANT:**
1. Be sure to clean and inspect sealing surfaces. Scratches / roughness cause leaks and seal wear. Unevenness causes seal extrusion. If defects cannot be polished out, replace the component.
  2. Be sure to use only specified O-rings. Inspect O-rings for any damage. Take care not to file O-ring surfaces. When installing an O-ring into a groove, use grease to hold it in place.
  3. While lightly tightening split flange halves, check that split is centered and perpendicular to the port. Hand-tighten bolts to hold parts in place. Take care not to pinch the O-ring.
  4. Tighten bolts alternately and diagonally, as shown, to ensure even tightening.
  5. Do not use air wrenches. Using an air wrench often causes tightening of one bolt fully before tightening of the others, resulting in damage to O-rings or uneven tightening of bolts.

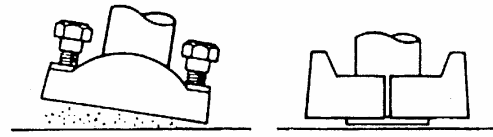

W105-01-01-015

**WRONG**

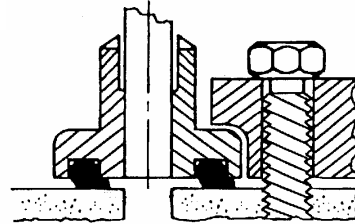

W105-01-01-016

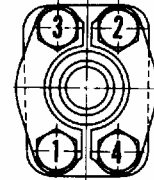

**RIGHT**

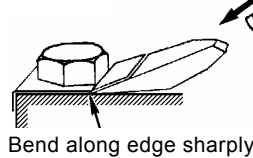

Bend along edge sharply

**WRONG**

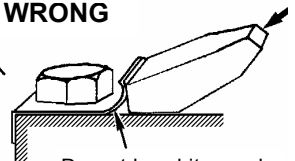

Do not bend it round

W105-01-01-008

## Nut and Bolt Locking

- Lock Plate

**IMPORTANT:** Do not reuse lock plates. Do not try to bend the same point twice.

- Cotter Pin

**IMPORTANT:** Do not reuse cotter pins. Match the holes in the bolt and nut while tightening, not while loosening.

- Lock Wire

**IMPORTANT:** Apply wire to bolts in the bolt-tightening direction, not in the bolt-loosening direction.

**RIGHT**

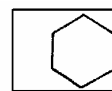

Bend along edge sharply

**RIGHT**

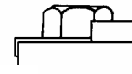
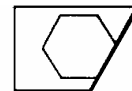

**WRONG**

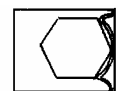

W105-01-01-009

**RIGHT**

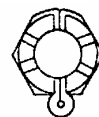

**RIGHT**



**WRONG**

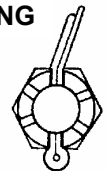

**RIGHT**

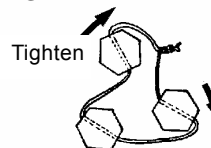

Tighten

Loosen

**WRONG**

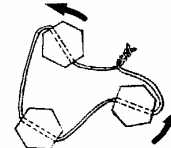

W105-01-01-010

## GENERAL / Bleeding Air from Hydraulic Oil Tank

### BLEEDING AIR FROM HYDRAULIC OIL TANK



**CAUTION:** Escaping fluid under pressure can penetrate the skin, causing serious injury. Avoid the hazard by relieving pressure before disconnecting hydraulic or other lines.

Hydraulic oil may be hot just after operation, and may spurt, possibly causing severe burns. Be sure to wait for oil to cool before starting work.

The hydraulic oil tank cap may fly off if removed without releasing internal pressure first. Push the air release valve on top of the hydraulic oil tank to release any remaining pressure.

#### Preparation

1. Place the machine on a firm, level surface and lower the bucket to the ground.

2. Stop the engine. Push the air bleed valve (1) on the air breather to release any remaining pressure from hydraulic oil tank (3).

3. Remove cap (2) of hydraulic oil tank (3).

4. Connect a vacuum pump with the hole removed cap (2) to maintain negative pressure in the hydraulic oil tank (3).

 **NOTE:** Be sure to run the vacuum pump continuously while working.

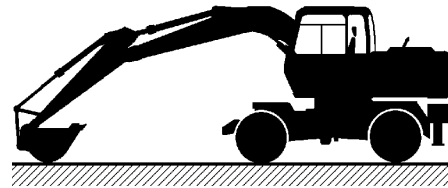

WCJB-01-04-001

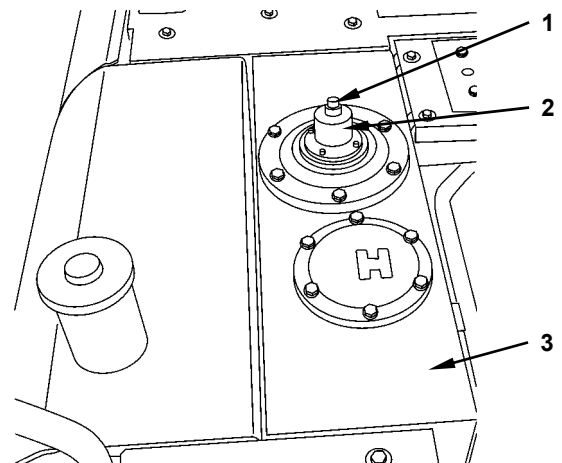

WCEB-01-04-001

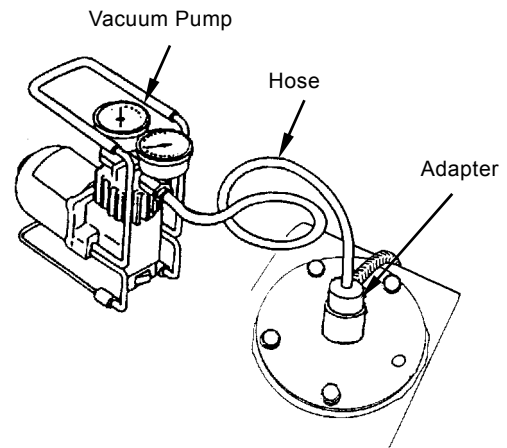

W562-02-03-008

## UPPERSTRUCTURE / Cab

18. Open cover (40).

19. Remove sems bolts (41) (4 used) from cover (39).  
Remove cover (39) from stay (42).

 : 17 mm

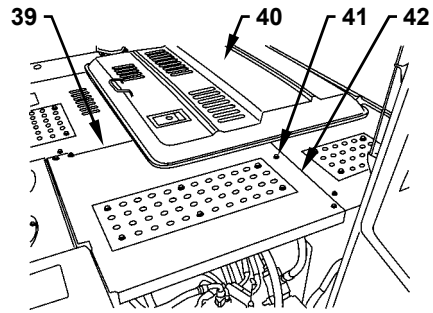

WCJB-02-01-002

20. Remove clamps (44) (3 used) from the outside of the cab (7) rear. Disconnect connectors (43) (5 used).

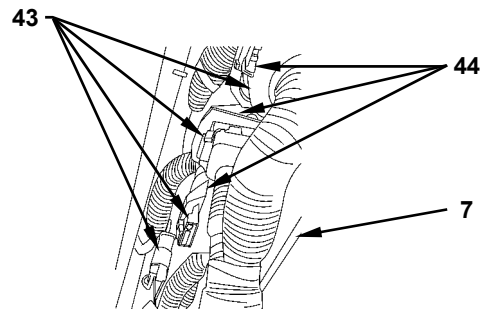

WCEB-02-01-014

 **CAUTION: Cab (7) weight: 550 kg (1220 lb)**

21. Attach a nylon sling onto the bracket in cab (7).  
Hold cab (7).

22. Remove nuts (45) (4 used) and washers (46) (4 used) from cab (7).

 : 24 mm

23. Remove socket bolts (47) (6 used) from cab (7).

 : 8 mm

24. Remove bolts (48) (5 used) and washers (49) (5 used) from cab (7).

 : 17 mm

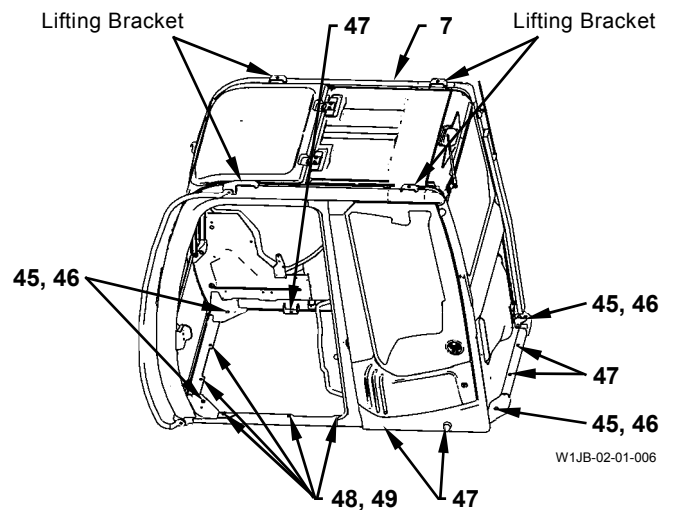

W1JB-02-01-006

 **CAUTION: Cab (7) weight: 550 kg (1220 lb)**

25. Remove cab (7) from main frame (34).

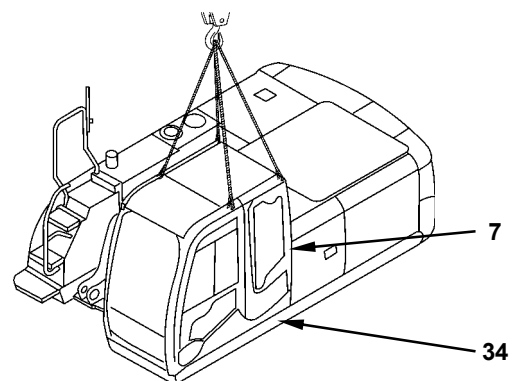

WCJB-02-01-006



## UPPERSTRUCTURE / Counterweight

### REMOVAL AND INSTALLATION OF COUNTERWEIGHT

#### Removal

1. Open cover (1).

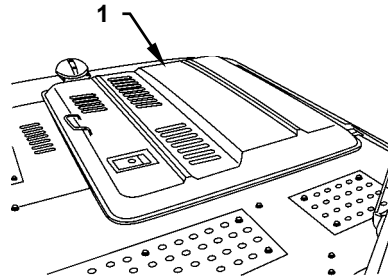

WCJB-02-02-002

2. Disconnect plugs (2, 3).

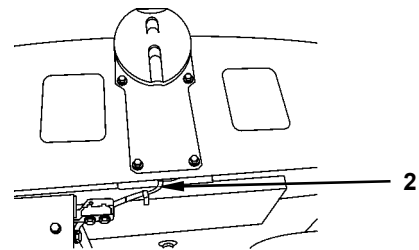

WCJB-02-02-003

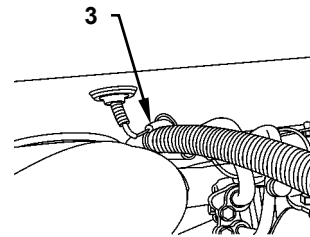

WCJB-02-02-004

3. Open cover (4).

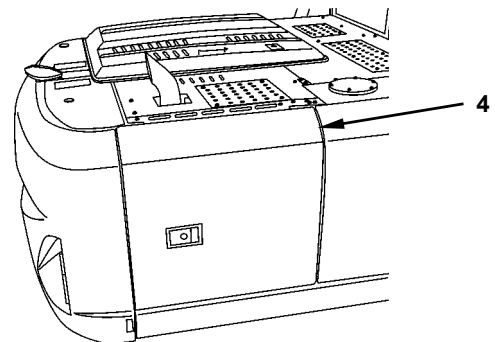

WCJB-02-02-001

4. Disconnect connector (5).

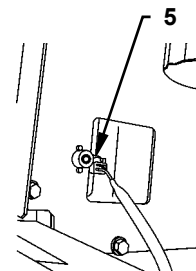

WCJB-02-02-005

## UPPERSTRUCTURE / Pump Device

### REMOVAL AND INSTALLATION OF PUMP DEVICE



**CAUTION:** Bleed air from the hydraulic oil tank before doing any work. (Refer to **BLEED AIR FROM HYDRAULIC OIL TANK** on W1-4-1.)

#### Removal

1. Open cover (1).

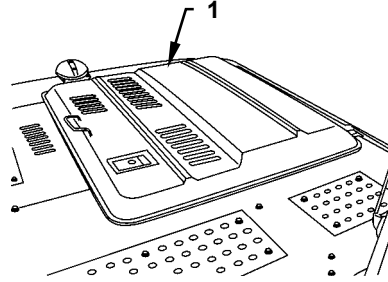

WCJB-02-02-002

2. Open cover (2).

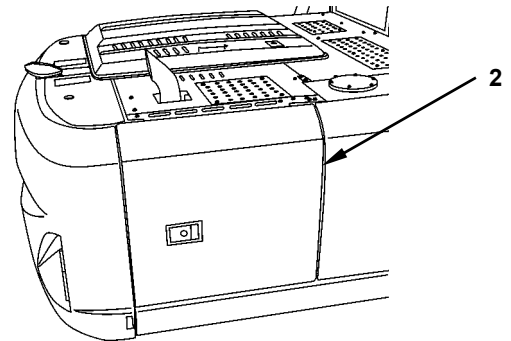

WCJB-02-02-001

3. Remove semi bolts (3) (4 used) from cover (4).  
Remove cover (4) from main frame (5).

 : 17 mm

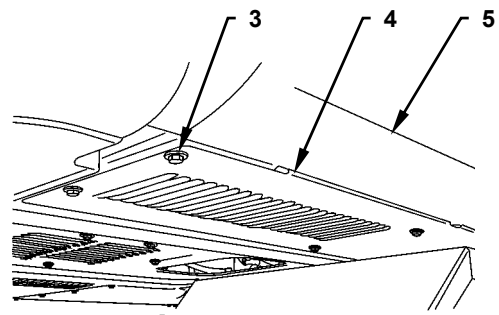

WCJB-02-04-007

## UPPERSTRUCTURE / Pump Device

20. Install bracket (7) to supports (13, 14) and cover (16) with sems bolts (12) (6 used) and sems bolts (15) (2 used).

 : 17 mm

 : 50 N·m (5 kgf·m, 37 lbf·ft)

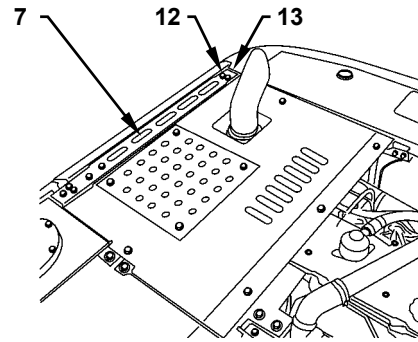

WCJB-02-04-001

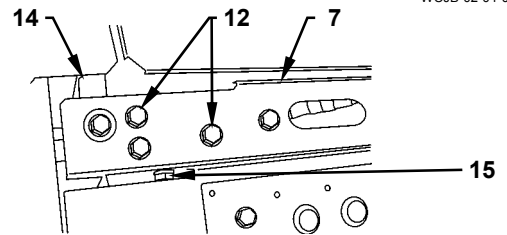

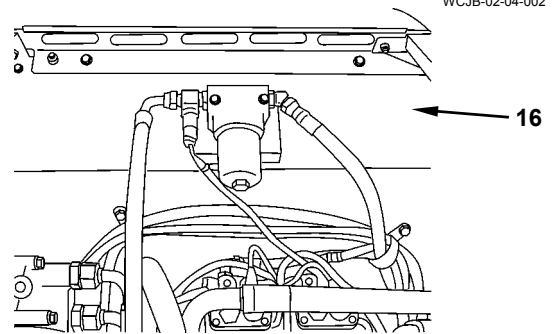

WCJB-02-04-002



WCJB-02-04-003

21. Install cover (8) to supports (10, 11), cover (16) and bracket (7) with sems bolts (9) (6 used) and sems bolts (6) (2 used).

 : 17 mm

 : 50 N·m (5 kgf·m, 37 lbf·ft)

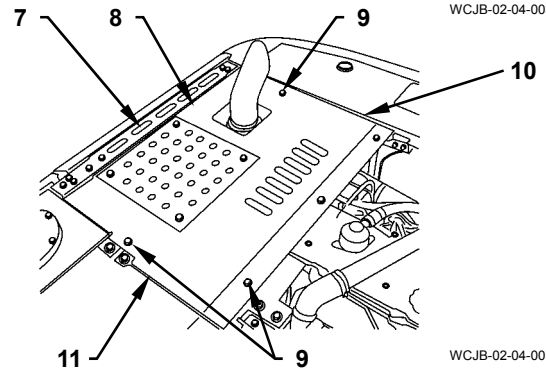

WCJB-02-04-001

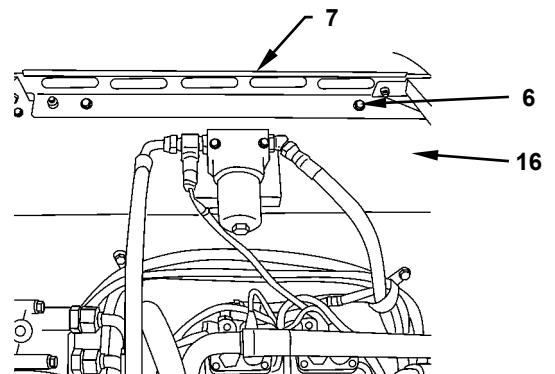

WCJB-02-04-003

## UPPERSTRUCTURE / Pump Device

---

18. Warm up set screws (76) (2 used) by using a drier. Remove set screws (76) (2 used) from servo pistons (77) (2 used). Remove pins (78) (2 used) from servo pistons (77) (2 used).

 : 6 mm

19. Remove servo pistons (77) (2 used) from selector head (70).

20. Both right valve plate (64) and left valve plate (81) are very similar and their installing directions are determined. Record the position and the direction of right valve plate (64) and left valve plate (81) before removing. Remove retaining rings (60) (4 used) from pins (63) (4 used). Remove right valve plate (64) and left valve plate (81) from links (83) (2 used). Do not remove pins (63) (4 used) unless necessary.

21. Remove rotor (18), spring (16), the center shaft (15) assembly and plungers (17) (7 used) from pump casing (53) in this order. (Both right and left pumps)

 **NOTE:** When removing plunger (17), turn plunger (17) inside and remove plunger (7).

**IMPORTANT:** As the pump performance may be changed, do not deform link (83).

22. Remove the link (83) assemblies (2 used) from pump casing (53). Do not disassemble the link (83) assembly unless necessary.

 **NOTE:** If it is difficult to remove the link (83) assembly, use a screwdriver.

23. Remove bolts (55) (6 used) and spring washer (54) from pump casing (53).

 : 24 mm



**CAUTION:** Pump casing (53) weight: 105 kg (240 lb)

24. Install eyebolts (M12, Pitch 1.75 mm) (2 used) to the socket bolt (75) hole on pump casing (53). Hoist and remove pump casing (53) from gear casing (49). Shafts (13, 19) and gears (27, 29) are removed with pump casing (53) together. Place pump casing (53) with the mounting surface for the regulator facing upward.

25. Remove spring pins (50) (2 used) and gasket (28) from gear casing (49).

## UPPERSTRUCTURE / Pump Device

---

10. Set the pre-loads of bearings (10, 12) installed on shaft (13) according to the following procedures.
- Apply hydraulic oil onto the thread part of bearing nut (9). Tighten bearing nut (9) until bearing nut (9) comes in contact with bearing (10) by using special tool (ST 3058).

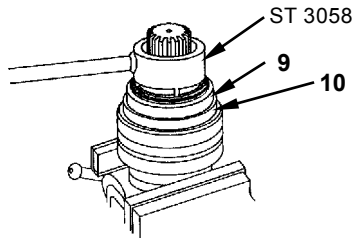

W178-02-11-090

- Install special tool (ST 3070) to bearing (10). Rotate 2 to 3 turns and measure the starting torque.

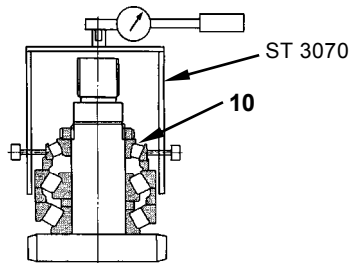

W178-02-11-091

- Adjust bearing nut (9) until the starting torque reaches specification.  
🔑 :  $1.96 \pm 0.49$  N·m  
( $0.20 \pm 0.05$  kgf·m,  $1.45 \pm 0.36$  lbf·ft)

 **NOTE:** If the starting torque is higher than the limit of specified torque, loosen bearing nut (9). Tap the shaft end and release the load of bearing (10).

11. Set the pre-loads of bearings (10, 12) installed on shaft (19) in the same way as step 10.
12. Install slide ring (20) to the side to insert shaft (19) in pump casing (53).

## UPPERSTRUCTURE / Pump Device

---

40. Apply hydraulic oil onto servo pistons (77) (2 used). Insert servo pistons (77) (2 used) into selector head (70).

41. Apply LOCTITE LI829 onto the thread part of set screws (76) (2 used). Install pins (78) (2 used) to servo pistons (77) (2 used) with set screws (76) (2 used).

 : 6 mm

 : 34.3 N·m (3.5 kgf·m, 25 lbf·ft)



**CAUTION: Selector head (70) weight: 29 kg (64 lb)**

42. Install eyebolts (M12, Pitch 1.75 mm) (2 used) into the thread hole for the suction pipe on selector head (70). Attach a nylon sling onto eyebolts (2 used). Hoist selector head (70).

Place selector head (70) on pump casing (53) while aligning selector head (70) with spring pin (67).

 **NOTE:** Check the clearance between selector head (70) and pump casing (53) in order to compare with the clearance before disassembling. If the clearance is larger, pin (14) may not be inserted into the groove on rotor (18), or pin (78) may not be inserted into the holes on valve plates (64, 81).

43. Install selector head (70) to pump casing (53) with socket bolts (75) (12 used).

 : 10 mm

 : 108 N·m (11 kgf·m, 80 lbf·ft)

44. Install O-rings (71) (4 used) to selector head (70).

45. Install O-rings (74) (2 used) to stoppers S (73) (2 used). Apply grease onto O-rings (74) (2 used). Install stoppers S (73) (2 used) to selector head (70) with socket bolts (72) (8 used).

 : 6 mm

 : 19.5 N·m (2.0 kgf·m, 14 lbf·ft)

46. Install O-rings (79) (2 used) to stoppers L (80) (2 used). Apply grease onto O-rings (79) (2 used). Install stoppers L (80) (2 used) to selector head (70) with socket bolts (72) (8 used).

 : 6 mm

 : 19.5 N·m (2 kgf·m, 14 lbf·ft)

## UPPERSTRUCTURE / Pump Device

Item	Part Name	Q'ty	Wrench Size (mm)	Tightening Torque		Remark
				N·m	(kgf·m, lbf·ft)	
1	Plate Seal	4				
2	Backup Ring	4				
3	Side Plate	4				
4	Rear Drive Gear	1				
5	Driven Gear	1				
6	Kmock Pin	8				
7	Gear Plate	2				
8	Cover	1				
9	Socket Bolt	4				
10	Coupling	1				
11	Stabilizer	2				
12	Center Plate	1				
13	Driven Gear	1				
14	Front Drive Gear	1				
15	Flange	1				
16	Oil Seal	1				
17	Retaining Ring	1				

## UPPERSTRUCTURE / Control Valve

---

(Blank)

# UPPERSTRUCTURE / Control Valve

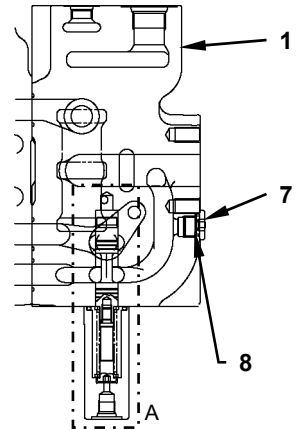
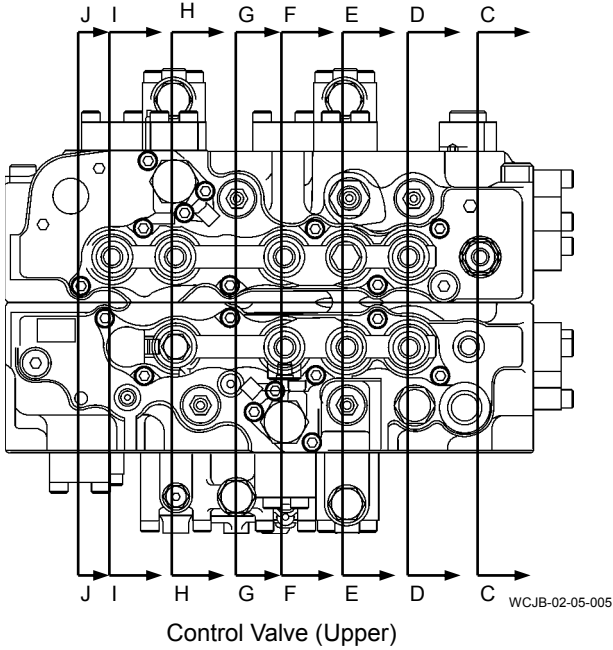

W1V1-02-05-038

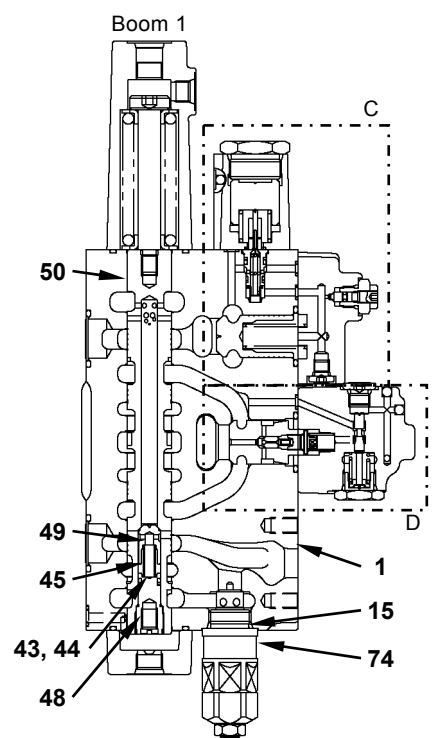
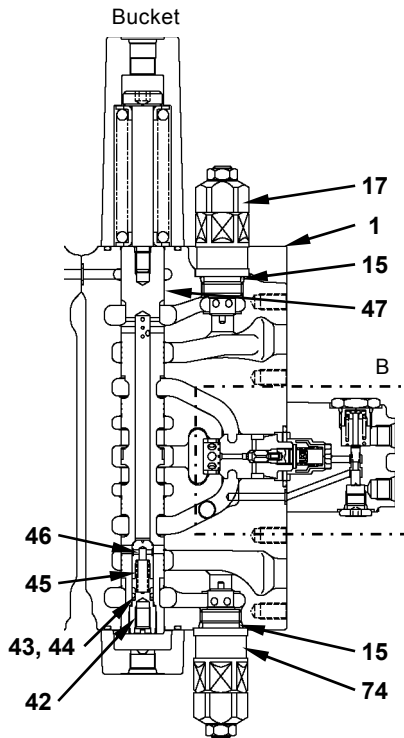
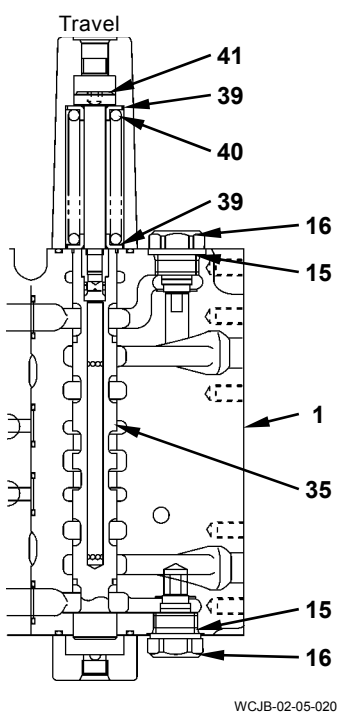

## UPPERSTRUCTURE / Control Valve

---

- Assembly of Bucket Flow Rate Control Valve

16. Install O-rings (96, 91) to plugs (97, 90).
17. Install spring (94), spool (93), spring seat (95) and plug (97) to body (92).
18. Install plug (90) to body (92).
19. Install poppet (85), spring (86) and plug (87) to poppet (84). Install the poppet (84) assembly, spring (88) and sleeve (89) into housing (1).

20. Install O-rings (18, 77) into housing (1). Install body (92) to housing (1) with socket bolts (98) (4 used).

 : 8 mm

 : 61±3 N·m (6.2±0.3 kgf·m, 45±2 lbf·ft)

- Assembly of Flow Combiner Valve

21. Install spring seat (71), spring (72) and spring seat (71) to bolt (70). Install bolt (70) to spool (73).

22. Install spool (73) and O-ring (4) to housing (1). Install cap (69) to housing (1) with socket bolts (68) (2 used).

 : 5 mm

 : 10 N·m (1 kgf·m, 7 lbf·ft)

- Assembly of Bypass Shut-Out Valve

23. Install spool (103), spring (104) and O-ring (4) to housing (1). Install flange (105) to housing (1) with socket bolts (6) (4 used).

 : 8 mm

 : 61±3 N·m (6.2±0.3 kgf·m, 45±2 lbf·ft)

- Assembly of Overload Relief Valve

**IMPORTANT: If the overload relief valve is disassembled, pressure must be adjusted.**

**(Refer to TROUBLESHOOTING / Operational Performance Test in the separated volume, T/M.)**

24. Install O-rings (15) (4 used) to overload relief valves (17, 74) (2 used for each). Install overload relief valves (17, 74) (2 used for each) to housing (1).

 : 32 mm

 : 83±5 N·m (8.5±0.5 kgf·m, 61±4 lbf·ft)

## UPPERSTRUCTURE / Control Valve

---

(Blank)

# UPPERSTRUCTURE / Control Valve

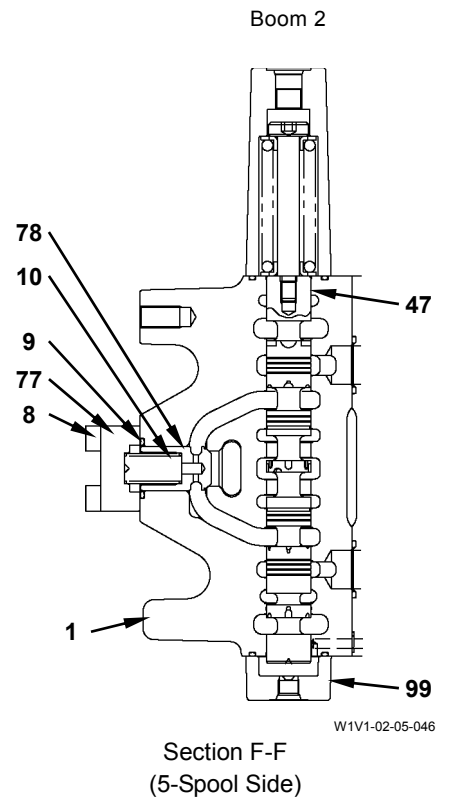
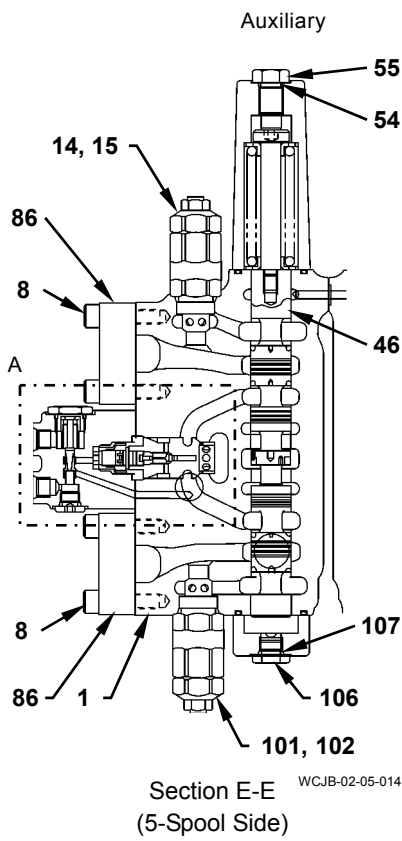
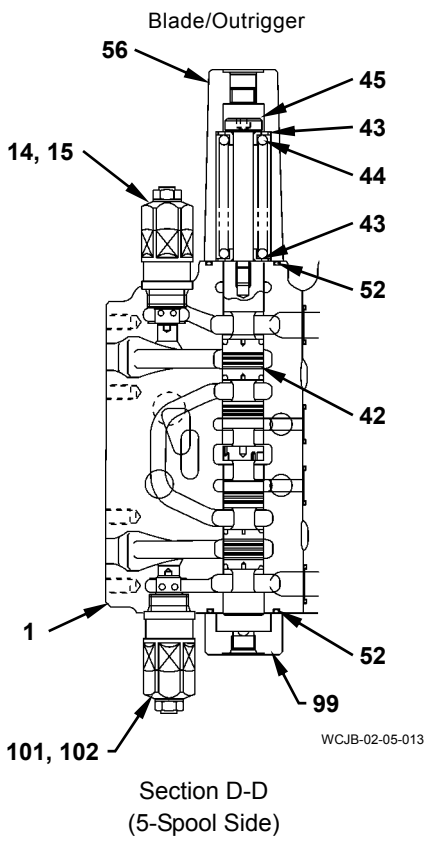
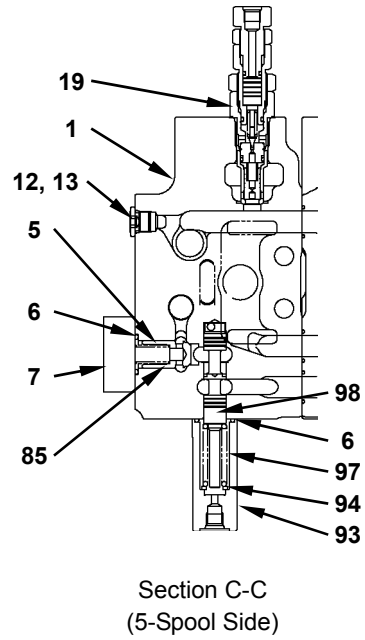
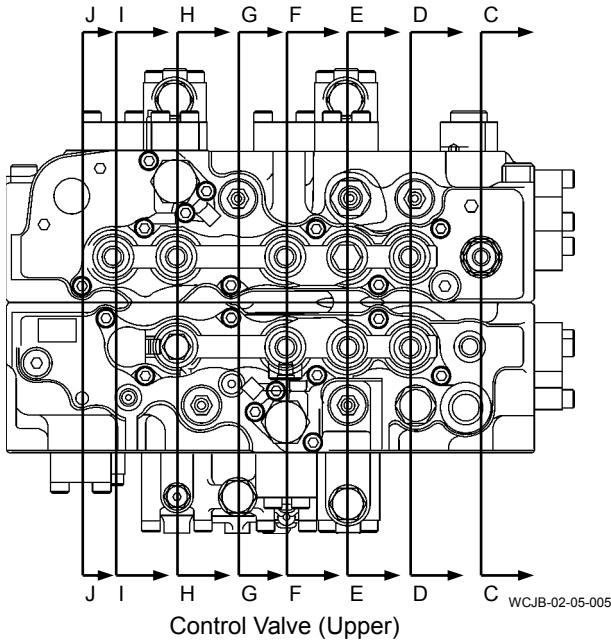

---

## UPPERSTRUCTURE / Control Valve

---

- Assembly of Load Check Valve

32. Install O-ring (89) to plug (88). Install poppet (91), spring (90) and plug (88) to housing (1).

33. Install poppet (78), spring (10) and O-ring (9) to housing (1). Install flange (77) to housing (1) with socket bolts (8) (4 used).

 : 8 mm

 : 61±3 N·m (6.2±0.3 kgf·m, 45±2 lbf·ft)

34. Install O-rings (2, 12) to plugs (3, 13). Install plugs (3, 13) to housing (1).

- Assembly of Overload Relief Valve

**IMPORTANT: If the overload relief valve is disassembled, pressure must be adjusted. (Refer to TROUBLESHOOTING / Operational Performance Test in the separated volume, T/M.)**

35. Install O-rings (14, 102) (2 used for each) to overload relief valves (15, 101) (2 used for each). Install overload relief valves (15, 101) (2 used for each) to housing (1).

 : 32 mm

 : 83±5 N·m (8.5±0.5 kgf·m, 61±4 lbf·ft)

36. Install O-ring (105) and backup ring (104) to plug (103). Install plug (103) to housing (1).

- Assembly of Main Relief Valve

**IMPORTANT: If the main relief valve is disassembled, pressure must be adjusted. (Refer to TROUBLESHOOTING / Operational Performance Test in the separated volume, T/M.)**

37. Install main relief valve (19) to housing (1).

 : 32 mm

 : 83±5 N·m (8.5±0.5 kgf·m, 61±4 lbf·ft)

- Assembly of Check Valve

38. Install poppet (4), spring (5) and O-ring (6) to housing (1). Install flange (7) to housing (1) with socket bolts (8) (2 used).

 : 8 mm

 : 61±3 N·m (6.2±0.3 kgf·m, 45±2 lbf·ft)

39. Install poppet (11), spring (10) and O-ring (9) to housing (1). Install flange (7) to housing (1) with socket bolts (8) (2 used).

 : 8 mm

 : 61±3 N·m (6.2±0.3 kgf·m, 45±2 lbf·ft)

40. Install O-rings (12) (2 used) to plugs (13) (2 used). Install plugs (13) (2 used) to housing (1).

41. Install O-ring (2) to plug (3). Install plug (3) into housing (1).

## UPPERSTRUCTURE / Control Valve

---

### Assembly of Positioning Control Valve

1. Clamp seat (37) in a vise. Install O-ring (38), valve (39), spring (40), sleeve (41) and O-ring (42) to seat (37).



: 36 mm



: 59 N·m (6 kgf·m, 44 lbf·ft)

2. Insert poppet (44) and spring (43) into housing (62).

3. Install the seat (37) assembly to housing (62).



: 36 mm



: 59 N·m (6 kgf·m, 44 lbf·ft)

**IMPORTANT: Each of overload relief valve assemblies (1 to 18), (19 to 36) has a different set pressure. Do not install at an incorrect position.**

4. Install overload relief valve assemblies (1 to 18), (19 to 36) to housing (62).



: 32 mm



: 59 N·m (6 kgf·m, 44 lbf·ft)

5. Install O-ring (58) to plug (59).

6. Clamp spool (57) in a vise by using wooden pieces. Install plug (59) to spool (57). Install seat (55), springs (53, 54), seat (52) and end spool (51) from the opposite side.



: 9.8 N·m (1 kgf·m, 7 lbf·ft)



: 8 mm



: 18.6 N·m (1.9 kgf·m, 14 lbf·ft)

**IMPORTANT: Install the spool (57) assembly into housing (62) and check if it moves smoothly by hand.**

7. Insert spool (57) assemblies (51 to 59) into housing (62) from the port A1 side.



**NOTE:** *If any of spool assembly (51 to 59) is not straight inserted, forced insertion can result in flaws on the bore of housing (62) or spool (57). Insert it straight.*

8. Install O-rings (47, 56) to covers (46, 50). Install covers (46, 50) to housing (62) with socket bolts (45) (2 used) and socket bolts (48, 49).



: 6 mm



: 25.5 N·m (2.6 kgf·m, 19 lbf·ft)

## UPPERSTRUCTURE / Swing Device

23. Push shaft (30) by using a press. Remove shaft (30) from housing (25). At this time, the inner race of roller bearing (26) and sleeve (28) are removed with shaft (30) together.

24. Place special tool (ST 1460) for removing roller bearing (26) onto the stepped part of special tool (ST 1461) for removing roller bearing (26).

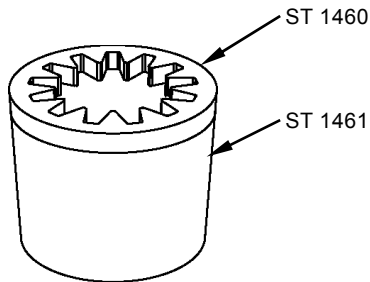

W178-02-06-010

**!** CAUTION: Shaft (30) weight: 40 kg (90 lb)

25. Insert the pinion gear of shaft (30) into tooth-hole of special tool (ST 1460). Set them onto a press.

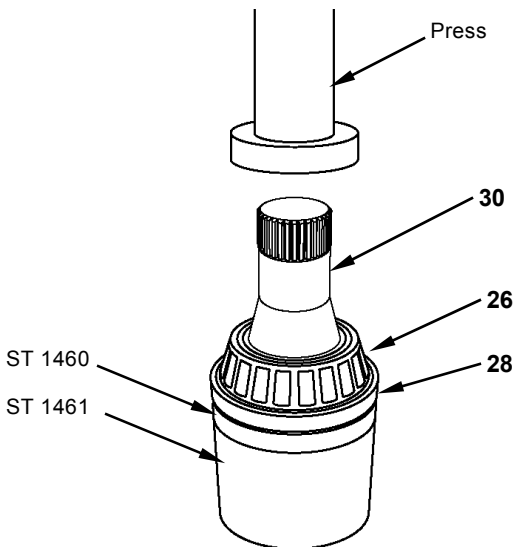

W178-02-06-009

26. Remove the splined side of shaft (30) by using a press. Remove the inner race of roller bearing (26) and sleeve (28) from shaft (30).

27. Remove O-ring (29) from sleeve (28).

28. Insert a round bar into the oil passage in housing (25). Tap and remove outer race of roller bearing (26).

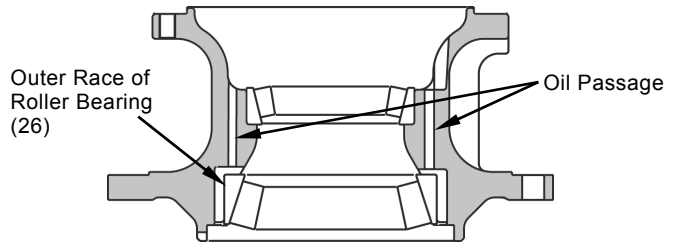

W178-02-06-001

**!** CAUTION: Housing (25) weight: 60 kg (140 lb)

29. Fasten the body of housing (25) by using a nylon sling. Hoist and turn over housing (25).

30. Insert a screwdriver into the notch on housing (25), where oil seal (27) is mounted. Remove oil seal (27) from housing (25).

**!** NOTE: *THREEBOND* has been applied onto the periphery of oil seal (27). Therefore, oil seal (27) cannot be reused.

31. Tap and remove the outer race of roller bearing (14) from housing (25) by using a bar and hammer.

## UPPERSTRUCTURE / Swing Device

### Disassembly of Swing Motor

**CAUTION:** The swing motor assembly weight: 47 kg (110 lb)

**IMPORTANT:** Do not disassemble relief valve (32).

1. Remove relief valves (32) (2 used) from valve casing (28).

 : 41 mm

2. Remove plugs (24) (2 used) from valve casing (28).

 : 14 mm

3. Remove springs (26) (2 used) and poppets (27) (2 used) from valve casing (28).

4. Put the matching marks on the jointed surface between valve casing (28) and casing (1). Remove socket bolts (29) (4 used) from valve casing (28). At this time, as the clearance exists between valve casing (28) and casing (1), record this clearance.

 : 17 mm

5. Remove valve casing (28) from casing (1).

 **NOTE:** At this time, as valve casing (28) may be removed with valve plate (21) together, do not drop valve plate (21).

6. Remove O-ring (23) from valve casing (28).

**IMPORTANT:** Do not damage the mating surfaces when separating valve plate (21) from valve casing (28) or rotor (9) by using a screwdriver. (Check the surfaces of valve plate (2) in order not to make a mistake for assembling.)

7. If valve plate (21) is still on rotor (9) in step 5, remove valve plate (21) from the rotor (19) side. Remove springs (20) (24 used) from brake piston (19).

**CAUTION:** There is also a method of applying air from port B in order to float brake piston (19). Prevent piston (13) from flying out.

8. Install special tool (ST 1468) to notch A of brake piston (19). Remove brake piston (19) from casing (1).

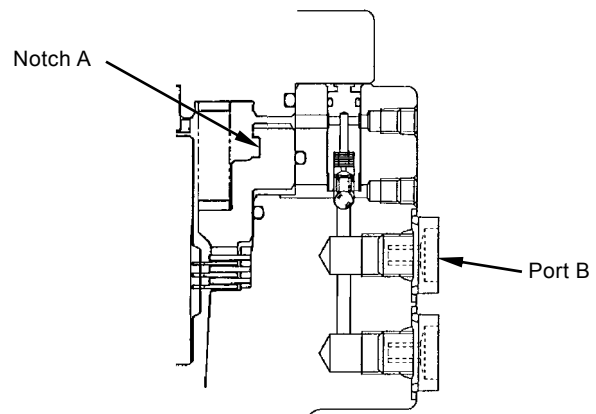

WCJB-02-06-003

9. Remove O-rings (17, 18) from casing (1).

## UPPERSTRUCTURE / Pilot Valve

### REMOVAL AND INSTALLATION OF PILOT VALVE

**CAUTION:** Bleed air from the hydraulic oil tank before doing any work. (Refer to **BLEED AIR FROM HYDRAULIC OIL TANK** on W1-4-1.)

#### Removal of Left Pilot Valve

**CAUTION:** Seat (1) weight: 40 kg (90 lb)

1. Remove sems bolts (4) (2 used) from seat belts (6) (2 used). Remove seat belt (6) from brackets (5) (2 used).

 : 16 mm

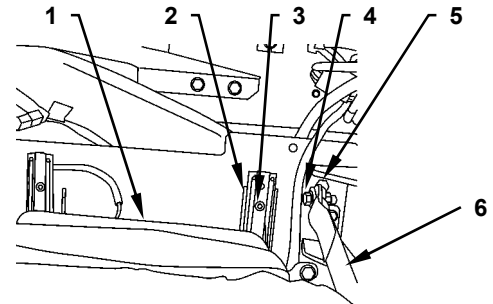

WCEB-02-01-001

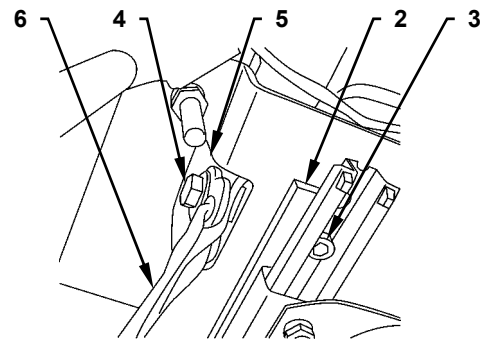

WCEB-02-01-017

2. Remove socket bolts (3) (4 used) from seat (1). Remove seat (1) from plate (2).

 : 6 mm

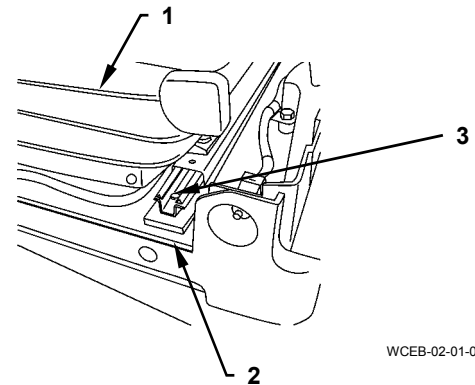

WCEB-02-01-002

3. Remove screws (9) (4 used) from boot (7). Raise boot (7) from bracket (8).

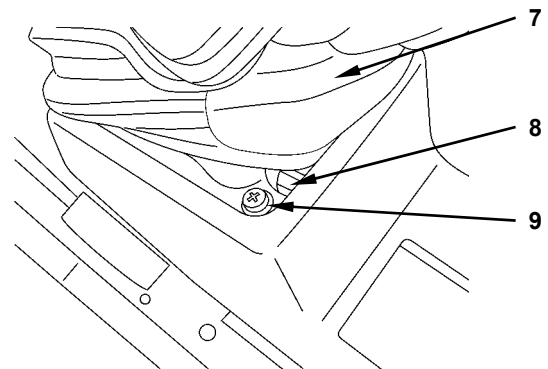

W1JB-02-07-002

## UPPERSTRUCTURE / Pilot Valve

### REMOVAL AND INSTALLATION OF TRAVEL PILOT VALVE

**⚠ CAUTION:** Bleed air from the hydraulic oil tank before doing any work. (Refer to **BLEED AIR FROM HYDRAULIC OIL TANK** on W1-4-1.)

#### Removal

1. Remove mat (1) from cab (2) inside.

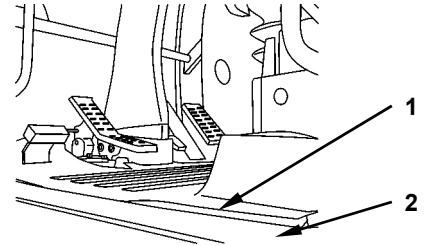

WCEB-02-01-003

2. Remove sems bolts (4) (2 used) from pedal (3).  
Remove pedal (3) from bracket (5).

 : 13 mm

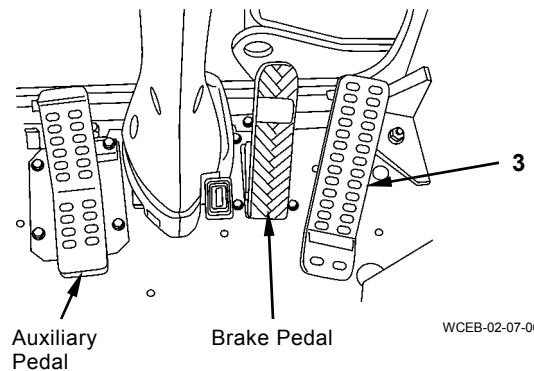

WCEB-02-07-002

3. Remove sems bolts (7) (2 used) from bracket (5).  
Remove bracket (5) from travel pilot valve (6).

 : 13 mm

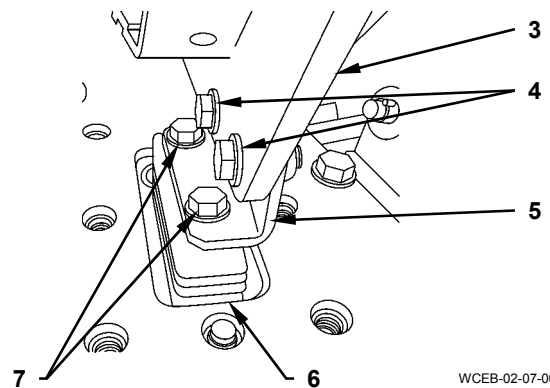

WCEB-02-07-007

## UPPERSTRUCTURE / Pilot Valve

### Assembly of Front/Swing Pilot Valves

- Replace the seals with the new ones.

1. Install bushing (16) and O-ring (15) to casing (14).
2. Install spring pin (17) to port plate (18). Install port plate (18) to casing (14) with socket bolts (20) (2 used) and seal washers (19) (2 used).  
🔧 : 20.5±2 N·m (2.1±0.2 kgf·m, 15±2 lbf·ft)

**IMPORTANT:** When installing spring seats (9) (4 used) to spool (13), insert spool (13) from a larger hole of 2 holes on spring seat (9) and move to a smaller hole direction. At this time, do not push in spool (13) for more than 6 mm (0.2 in).

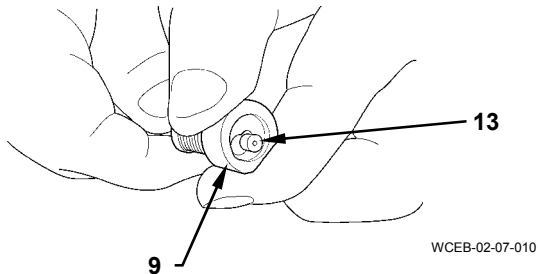

3. Install washers (12) (4 used), springs (11) (4 used) and spring seats (9) (4 used) to spools (13) (4 used) in this order.

**IMPORTANT:** Install spring (10) to the same position before disassembling.

4. Install springs (10) (4 used) to casing (14).

**IMPORTANT:** Install the spool (13) assemblies (4 used) to the same position as it was before disassembling.

5. Install the spool (13) assemblies (4 used) to casing (14).

6. Install O-rings (7) (4 used) and oil seals (5) (4 used) to bushings (6) (4 used).

**IMPORTANT:** Apply hydraulic oil onto the outer surface of pushers (8) (4 used).

7. Install pushers (8) (4 used) to bushings (6) (4 used).

**IMPORTANT:** If installing plate (4) is difficult due to strong springs (10) (4 used), place the bushing (6) assemblies (4 used) on 4 holes of casing (14). Place plate (4) on them. Temporarily secure the bushing (6) assemblies (4 used). While holding it with universal joint (3).

8. Install the bushing (6) assemblies (4 used) to casing (14), by aligning the matching marks before disassembly.

## UPPERSTRUCTURE / Electric Lever

3. Install bracket (10) to electric lever (11) with sems bolts (7) (2 used).

 : 13 mm

 : 20 N·m (2 kgf·m, 15 lbf·ft)

4. Install pedal (9) to bracket (10) with sems bolts (8) (2 used).

 : 13 mm

 : 20 N·m (2 kgf·m, 15 lbf·ft)

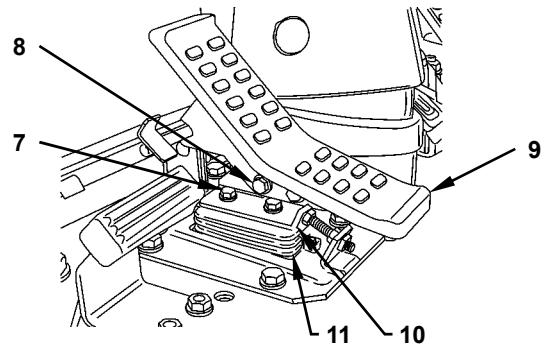

WCEB-02-08-001

5. Install mat (6) to the inside of cab (5).

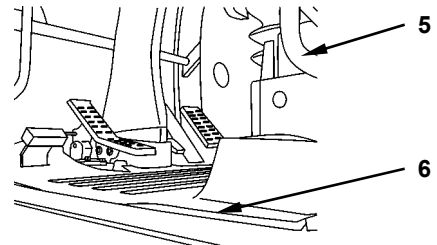

WCEB-02-01-003

6. Connect connector (4).

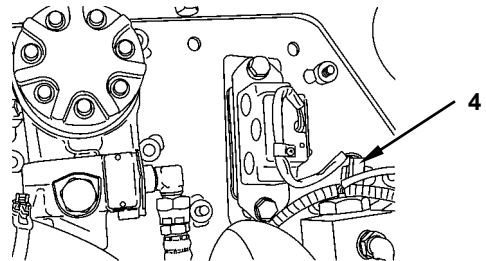

WCEB-02-08-002

7. Install cover (1) to main frame (3) with sems bolts (2) (6 used).

 : 17 mm

 : 50 N·m (5 kgf·m, 37 lbf·ft)

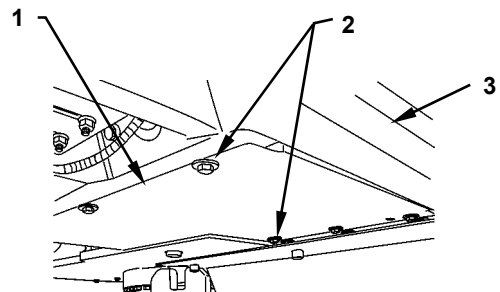

WCJB-02-13-001

CLICK HERE TO **DOWNLOAD** THE COMPLETE MANUAL

- Thank you very much for reading the preview of the manual.
- You can download the complete manual from: [www.heydownloads.com](http://www.heydownloads.com) by clicking the link below



- Please note: If there is no response to CLICKING the link, please download this PDF first and then click on it.

CLICK HERE TO **DOWNLOAD** THE COMPLETE MANUAL

## UPPERSTRUCTURE / Signal Control Valve

### REMOVAL AND INSTALLATION OF SIGNAL CONTROL VALVE



**CAUTION:** Bleed air from the hydraulic oil tank before doing any work. (Refer to **BLEED AIR FROM HYDRAULIC OIL TANK** on W1-4-1.)

#### Removal

1. Open cover (2).
2. Remove sems bolts (3) (4 used) from cover (1). Remove cover (1) from stay (4).

 : 17 mm

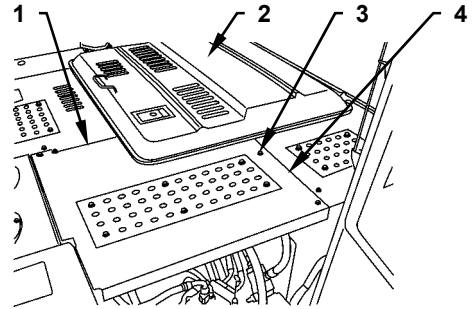

WCJB-02-01-002

3. Disconnect connectors (5) (2 used) from signal control valve (6).
4. Disconnect hoses (7) (32 used) from signal control valve (6). Cap the open ends. Attach an identification tag onto the disconnected hoses for assembling.

 : 17 mm, 19 mm

5. Remove socket bolts (8) (4 used) from signal control valve (6). Remove signal control valve (6) from bracket (9).

 : 8 mm

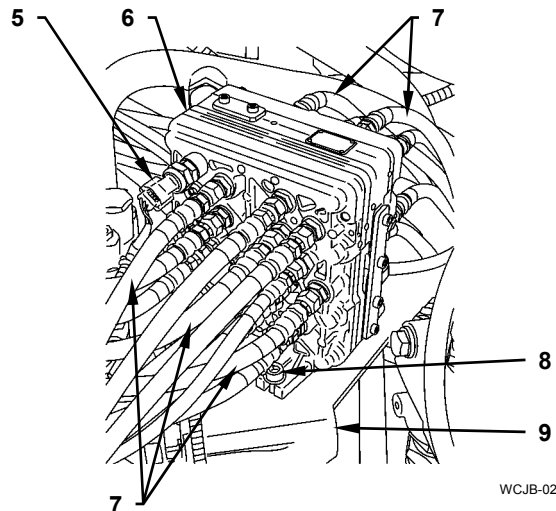

WCJB-02-09-001

## UPPERSTRUCTURE / Travel Shockless Valve

---

	Part Name	Q' ty	Wrench Size	Tightening Torque		
				N-m	(kgf·m)	(lbf-ft)
1	Solenoid	2				
2	O-Ring	2	1B P14			
3	Spool	2				
4	Body	1				
5	Spring	2				
6	Plug	6				
7	Orifice	2		1.6 to 2.0	(0.16 to 0.2)	(1.2 to 1.5)
8	Plug	2		13.2 to 17.6	(1.3 to 1.8)	(9.7 to 13)
9	Steel Ball	2	9/32			
10	Spring	2				
11	O-Ring	4	1B P8			
12	Plug	2		13.2 to 17.6	(1.3 to 1.8)	(9.7 to 13)
13	Nut	2	 : 19 mm	4.9	(0.5)	(3.6)
14	Tube	2		30 to 37	(3 to 4)	(22 to 27)

## UPPERSTRUCTURE / Pilot Shut-Off Solenoid Valve

### REMOVAL AND INSTALLATION OF PILOT SHUT-OFF SOLENOID VALVE



**CAUTION:** Bleed air from the hydraulic oil tank before doing any work. (Refer to **BLEED AIR FROM HYDRAULIC OIL TANK** on W1-4-1.)

#### Removal

1. Remove sems bolts (1) (6 used) from cover (2).  
Remove cover (2) from main frame (3).  
 : 17 mm

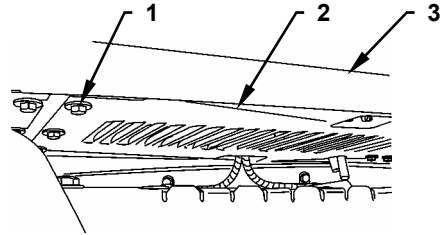

WCJB-02-15-001

2. Disconnect hoses (4) (9 used) from pilot shut-off solenoid valve (5). Cap the open ends. Attach an identification tag onto the disconnected hoses for assembling.

 : 17 mm, 19 mm

3. Disconnect connector (8).

4. Remove sems bolts (6) (4 used) from bracket (7).  
Remove the bracket (7) assembly from main frame (3).

 : 17 mm

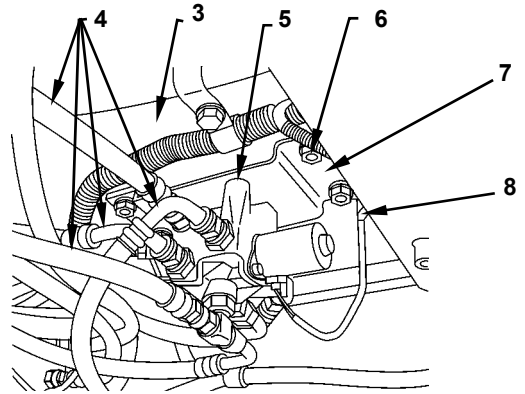

WCEB-02-12-001

5. Remove sems bolts (9) (2 used) from bracket (7).  
Remove bracket (7) from pilot shut-off solenoid valve (5).

 : 17 mm

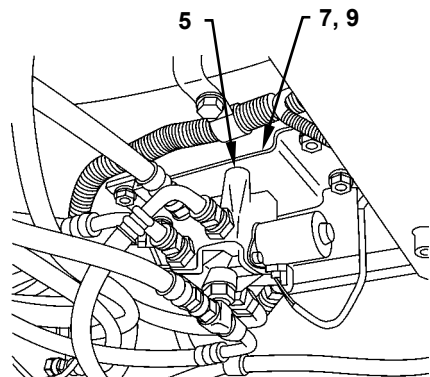

WCEB-02-12-001

## UPPERSTRUCTURE / Brake Valve

### REMOVAL AND INSTALLATION OF BRAKE VALVE



**CAUTION:** Bleed air from the hydraulic oil tank before doing any work. (Refer to **BLEED AIR FROM HYDRAULIC OIL TANK** on W1-4-1.)

#### Removal

1. Remove mat (1) from the inside of cab (2).

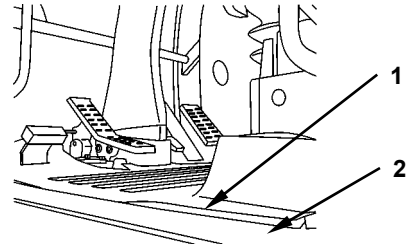

WCEB-02-01-003

2. Remove sems bolts (4) (6 used) from cover (3). Remove cover (3) from main frame (5).

 : 17 mm

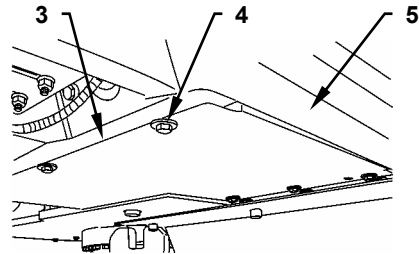

WCJB-02-13-001

3. Disconnect connector (11).

4. Remove socket bolts (7) (2 used) from bracket (6). Remove the bracket (6) assembly from bracket (8).

 : 6 mm

5. Disconnect hoses (9) (6 used) from brake valve (10). Cap the open ends. Attach an identification tag onto the disconnected hoses for assembling.

 : 17 mm, 22 mm, 27 mm

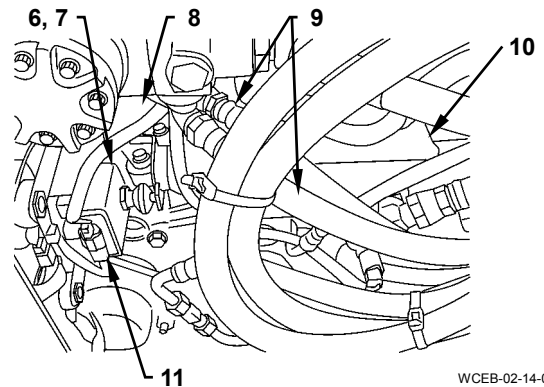

WCEB-02-14-005

6. Remove rubber (14) from brake pedal (15).

7. Remove sems bolts (12) (4 used) from plate (13). Remove the brake valve (10) assembly from plate (13).

 : 17 mm

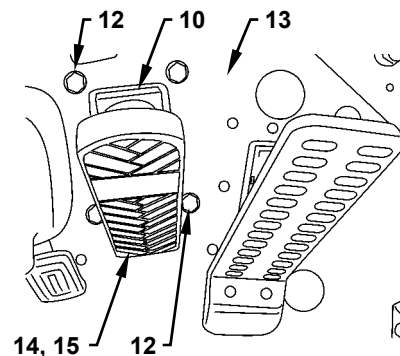



WCEB-02-14-006

## UPPERSTRUCTURE / Brake Valve

---

### Assembly of Brake Valve

1. Install oil seal (27) to flange (28).
2. Secure flange (28) in a vise with the oil seal (27) side facing downward.
3. Install O-ring (29) to flange (28).
4. Apply hydraulic oil onto rod (30), pilot piston (37), push rod (38), plungers (47) (2 used) and spools (48) (2 used).
5. Install push rod (38), pilot piston (37), retainer (36), retainer (35), return spring (31), balance spring (34), spring (33), holder (32) and rod (30) to flange (28) in this order.
6. Install O-ring (29) to cylinder (39).
7. Align the matching marks and place cylinder (39) onto the flange (28) assembly.
8. Install retainer (46) and retaining ring (45) to spool (48).
9. Install the spool (48) assembly to cylinder (39).
10. Install spring (49), plunger (47) and spring (44) to cylinder (39).
11. Align the matching marks and place cylinder (40) onto cylinder (39).
12. Install retainer (46) and retaining ring (45) to spool (48).
13. Install the spool (48) assembly to cylinder (40).
14. Install plunger (47), spring (44) and plug (42) to cylinder (40).  
 : 130 to 180 N·m  
(13 to 18 kgf·m, 96 to 133 lbf·ft)
15. Connect flange (28), cylinder (39) and cylinder (40) with socket bolts (43) (4 used).  
 : 60 to 75 N·m  
(6 to 7.5 kgf·m, 44 to 55 lbf·ft)



# UNDERCARRIAGE / Swing Bearing

## Assembly of Swing Bearing

**IMPORTANT:** Apply grease onto balls (5) (111 used) and supports (8) (111 used)



**CAUTION:** Outer race (4) weight: 96 kg (211 lb)  
Inner race (7) weight: 114 kg (251 lb)

1. Hoist outer race (4) horizontally and align outer race (4) with inner race (7) coaxially. While rotating outer race (4), insert balls (5) and supports (8) into the plug hole by using a round bar.

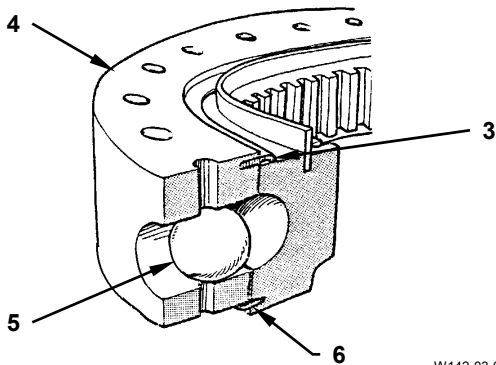

W142-03-01-005

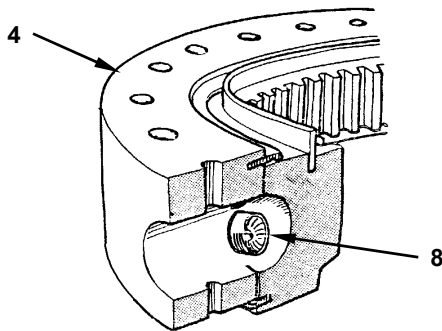

W142-03-01-006

2. Tap and install plug (1) into outer race (4). Secure plug (1) to outer race (4) with pin (2). Crimp the head of pin (2) by using a punch.

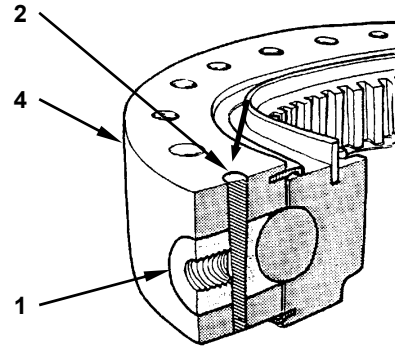

W142-03-01-007



**CAUTION:** Swing bearing weight: 230 kg (510 lb)

3. Install lifting tool (ST 0050) to outer race (4). Hoist outer race (4). Thoroughly degrease the slots for seals (3, 6). Apply THREEBOND #1745 to seal (3) and #1530D to seal (6). Install seals (3, 6) to outer race (4) and inner race (7).
4. Add grease 0.5 L (0.1 US gal.) (Alvania EP2 grease or equivalent) to the swing bearing through grease fitting (9). At this time, rotate outer race (4) and add grease.

## UNDERCARRIAGE / Travel Motor

12. Before removing, record the dimensions of part B and part C.

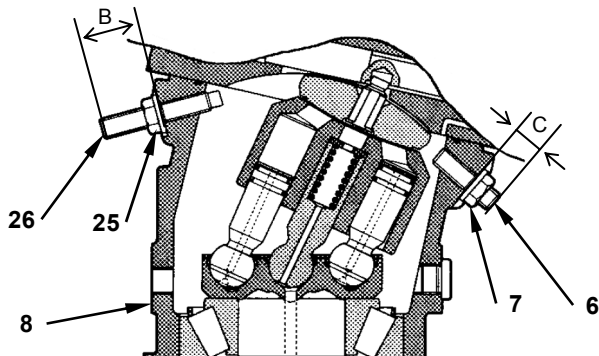

W1GL-03-02-005

13. Loosen lock nuts (7, 24). Remove adjusting screws (6, 25) from housing (8).
14. Install adjusting screw (25) (M12, Pitch 1.75 mm, Length 100 mm) to adjusting screw (6) mounting part, so that the angle of center shaft (21) should be zero.

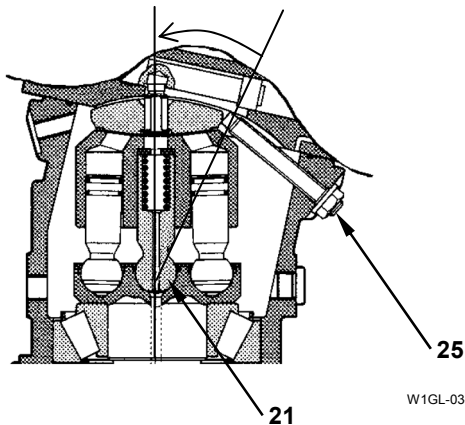

W1GL-03-02-004

15. Put the matching marks on the contacting surface of head cover (36) and housing (8). Remove socket bolts (51) (8 used). Remove head cover (36) from housing (8).

16. Secure rotor (23), center shaft (21) and plungers (9) (7 used) by using a screw bar (M8, Pitch 1.25 mm, Length 120 mm). Remove adjusting screw (25) from housing (8).

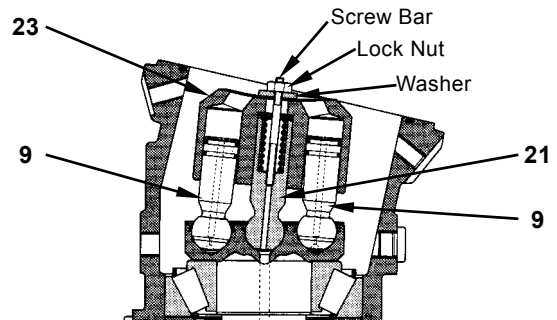

W1GL-03-02-003

17. Remove retaining ring (16) and shim (15) from housing (8).
18. Set the housing (8) assembly in a vise with the rotor (23) side facing downward. Remove the drive shaft (20) assembly from housing (8).
19. Remove oil seal (14) from housing (8).

## UNDERCARRIAGE / Travel Motor

---

23. Install relief valves (49) (2 used) and plugs (50) (2 used) to head cover (36).

 : 27 mm

 : 78 N·m (8 kgf·m, 58 lbf·ft)

 : 32 mm

 :  $83\pm 5$  N·m ( $8.5\pm 0.5$  kgf·m,  $61\pm 4$  lbf·ft)

24. Install brake valve (37) and O-rings (38) (2 used) to head cover (36) with socket bolts (48) (2 used).

 : 5mm

## UNDERCARRIAGE / Center Joint

---

9. Install clips (1) (2 used) to center joint (5) with bolt (3) and washer (4).

 : 10 mm

 : 3.3 to 4.2 N·m  
(0.3 to 0.4 kgf·m, 2 to 3 lbf·ft)

10. Connect connectors (2) (2 used).

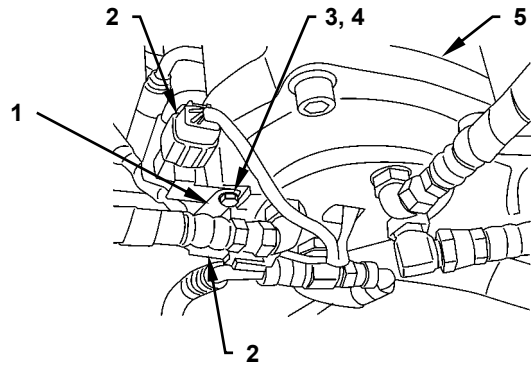

WCJB-03-03-002

## UNDERCARRIAGE / Transmission

---

(Blank)

## UNDERCARRIAGE / Transmission

---

15. Remove oil seals (6, 48) from brake piston (45).

**IMPORTANT: Do not remove bearing (52) unless necessary.**

16. Remove bearing (52) and pales (53) (2 used) from shaft (49).

17. Remove holder (51) and spring (50) from shaft (49).

18. Remove the ring (44) assembly from housing (22).

19. Remove ring (43), seal ring (8), O-rings (9) (2 used), O-ring (42) and gasket (10) from the ring (44) assembly.

20. Remove friction plates (12) (6 used), plates (11) (7 used) and disc plate (13) from housing (22).

21. Remove retaining ring (14) and shim (15) from housing (22).

22. Remove friction plates (41) (10 used) and plates (40) (9 used) from housing (22).

23. Remove disc plate (39) from housing (22).

24. Remove the shaft (49) assembly from housing (22).

25. Remove shaft (49) from ring gear (34).

26. Remove retaining ring (20) from shaft (49). Remove collar (38).

**IMPORTANT: Do not remove bearing (37) unless necessary.**

27. Remove retaining rings (35, 36) from ring gear (34). Remove bearing (37).

28. Remove bearing (30) and washers (31) (2 used) from planetary carrier (32).

29. Remove bolts (25) (4 used). Remove plate (29) from housing (22).

 : 17 mm

30. Remove planetary carrier (32) from housing (22).

**IMPORTANT: Do not remove bearings (21, 23) unless necessary.**

31. Remove the inner races of bearings (21, 23) from planetary carrier (32).

**IMPORTANT: Do not remove bearings (21, 23) unless necessary.**

32. Remove the outer races of bearings (21, 23) from housing (22).

**IMPORTANT: Do not remove bearing (19) unless necessary.**

33. Remove retaining rings (17) (3 used), washers (18) (3 used) and bearings (19) (3 used) from planetary gears (16) (3 used).

34. Remove slot pins (33) (6 used) from planetary gear (16).

## UNDERCARRIAGE / Transmission

10. Install the cover (60) assembly to housing (22).  
Temporarily tighten with nuts (103) (2 used) and washers (104) (2 used).

 : 19 mm

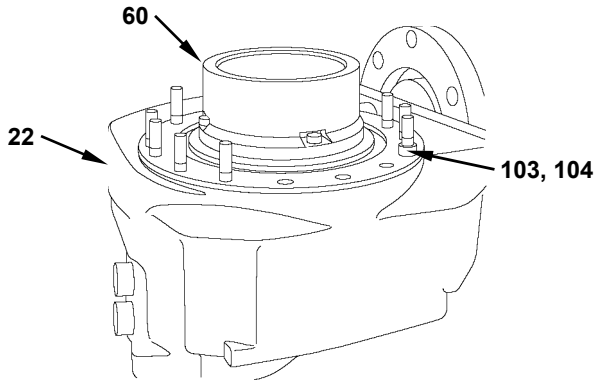

WCGB-03-04-010

11. Install the inner race of bearing (61), bushing (64) and O-ring (59) to pinion (62).
12. Install pinion (62) to housing (22). Install special tool (ZF special tool No. 5870 654 049) to housing (22). Tighten pinion (62).
13. Hoist and turn over housing (22) with the rear axle mounting side facing downward.
14. Install ring (56) and the inner race of bearing (55) to pinion (62).
15. Install O-ring (69) and plate (72) to housing (22). Temporarily tighten with bolts (70) (2 used). At this time, turn pinion (62) to both directions 7 times and take up slack.

 : 17 mm

 : 46 N·m (4.7 kgf·m, 34 lbf·ft)

16. Turn pinion (62) and measure the preload. If the proper preload cannot be obtained, reassemble from step 14.

 **NOTE:** Proper preload: 1.5 to 3.0 N·m (0.2 to 0.3 kgf·m, 1.0 to 2.0 lbf·ft)

17. Tighten pinion (62) in a direction opposite to step 12 by using special tool (ZF special tool No. 5870 654 049). Remove special tool (ZF special tool No. 5870 654 049).

18. Turn pinion (62) and measure the preload. If the proper preload cannot be obtained, reassemble from step 14.



 **NOTE:** Proper preload: 1.5 to 3.0 N·m (0.2 to 0.3 kgf·m, 1.0 to 2.0 lbf·ft)

19. Remove temporarily installed bolts (70) (2 used). Remove flange (68) and plate (72) from housing (22).

 : 17 mm

## UNDERCARRIAGE / Transmission





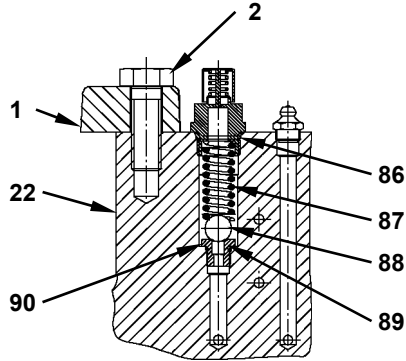

71. Install O-rings (86, 89), plug (90), steel ball (88) and spring (87) to housing (22).

-  : 8 mm
-  : 24 N·m (2.4 kgf·m, 18 lbf·ft)



WCGB-03-04-007





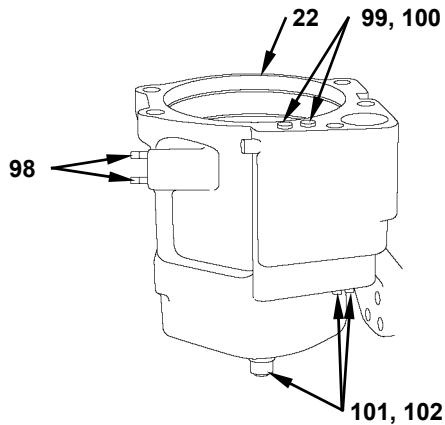



72. Install bleeder valves (98) (2 used), plugs (99) (2 used), plugs (101) (3 used), seal rings (100) (2 used) and O-rings (102) (3 used) to housing (22).

- Bleeder valve (98)**
-  : 17 mm
-  : 22 N·m (2.2 kgf·m, 16 lbf·ft)
- Plug (99)**
-  : 8 mm
-  : 15 N·m (1.5 kgf·m, 11 lbf·ft)
- Plug (102)**
-  : 8 mm
-  : 25 N·m (2.5 kgf·m, 18 lbf·ft)



WCGB-03-04-008

73. Install bleeder (85), bleeder valve (93), fitting (97) and plugs (91, 92) to housing (22).

- Bleeder (85)**
-  : 27 mm
-  : 22 N·m (2.2 kgf·m, 16 lbf·ft)
- Bleeder valve (93)**
-  : 17 mm
-  : 22 N·m (2.2 kgf·m, 16 lbf·ft)
- Fitting (97)**
-  : 17 mm
-  : 22 N·m (2.2 kgf·m, 16 lbf·ft)
- Plugs (91, 92)**
-  : 8 mm
-  : 25 N·m (2.5 kgf·m, 18 lbf·ft)

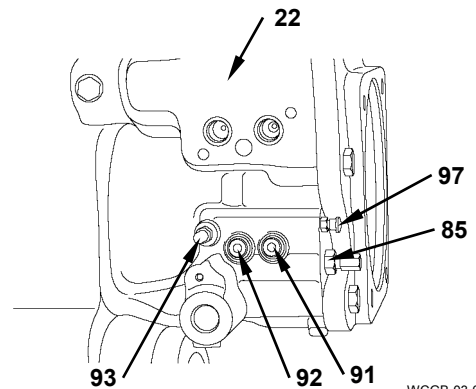

WCGB-03-04-013

## UNDERCARRIAGE / Axle

### Installation of Rear Axle



**CAUTION: Rear axle weight:**  
ZX210W-3: 600 kg (1330 lb)  
ZX220W-3: 630 kg (1390 lb)

1. Hold the rear axle by using a forklift. Install the rear axle to frame (4) with bolts (14) (8 used) and nuts (15) (8 used).

 : 30 mm

 : 560 N·m (57 kgf·m, 410 lbf·ft)

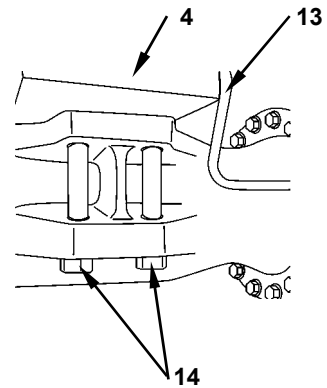

WCGB-03-05-023

2. Connect brake pipings (13) (2 used) to the right and left sides of the rear axle.

 : 19 mm

 : 29.5 N·m (3 kgf·m, 22 lbf·ft)

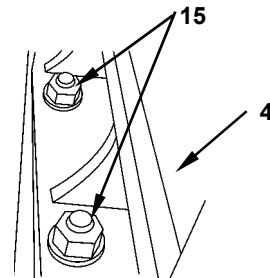



WCGB-03-05-022



**CAUTION: The transmission (5) assembly weight: 220 kg (490 lb)**

3. While holding the transmission (5) assembly by using a forklift, align it with the rear axle. Install the transmission (5) assembly to the rear axle with bolts (12) (14 used).

 : 19 mm

 : 250 N·m (26 kgf·m, 185 lbf·ft)

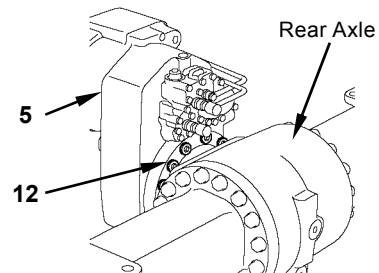



WCGB-03-05-032

4. Connect hoses (9) (9 used) and connector (11) to transmission (5) and travel motor (10).

(Hose):

 : 19 mm

 : 29.5 N·m (3 kgf·m, 22 lbf·ft)

 : 22 mm

 : 39 N·m (4 kgf·m, lbf·ft)

 : 27 mm

 : 78 N·m (8 kgf·m, 58 lbf·ft)

(Socket bolt):

 : 12 mm

 : 140 N·m (14 kgf·m, 105 lbf·ft)

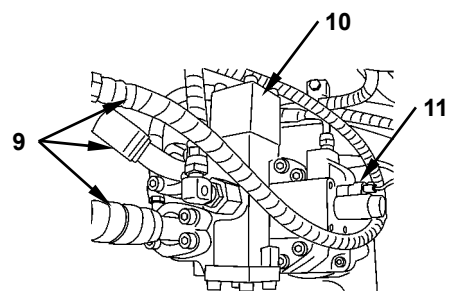

WCGB-03-05-030

## UNDERCARRIAGE / Axle

---

25. Remove double joint shaft (16) from knuckle (19).
26. Remove shaft seal (17) and bushing (18) from knuckle (19).
27. Remove shaft seal (15) and bushing (14) from axle casing (1).

**IMPORTANT: Do not remove bearings (10, 11) unless necessary.**

28. Remove the outer races of bearings (10, 11) from axle casing (1).



**CAUTION: Axle casing (1) weight:**  
**ZX210W-3: 98 kg (220 lb)**  
**ZX220W-3: 107 kg (240 lb)**

29. Attach a nylon sling onto axle casing (1). Hoist and hold axle casing (1). Remove bolts (2) (16 used) and washers (3) (16 used). Hoist and remove axle casing (1) from drive housing (6).

 : 27 mm

**IMPORTANT: Do not remove roller bearing (7) unless necessary.**

30. Remove O-ring (9), shim (8) and roller bearing (7) from axle casing (1).
31. Disassemble the other side of the front axle in the same way as steps 4 to 30.

32. Remove differential (70) from drive housing (6).

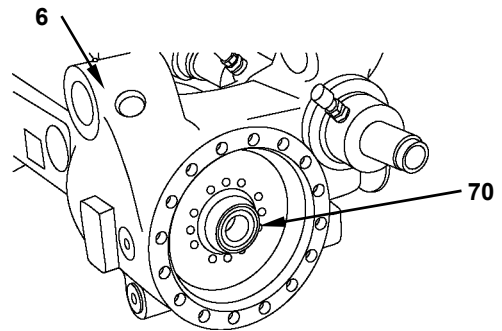

WCGB-03-05-003





## UNDERCARRIAGE / Axle

---

31. Install retaining rings (48, 53) (3 used for each), washers (50, 52) (3 used for each) and roller bearings (51) (3 used) to planetary gears (49) (3 used).
32. Install planetary gears (49) (3 used) to planetary carrier (44) with retaining rings (54) (3 used).



**CAUTION: Planetary carrier (44) weight: 30 kg (70 lb)**

33. Hoist planetary carrier (44). Install planetary carrier (44) to the front axle with socket bolts (47) (2 used).
  -  : 10 mm
  -  : 90 N·m (9 kgf·m, 66 lbf·ft)
34. Assemble the other side of the front axle in the same way as steps 2 to 33.
35. Assemble tie rods (12, 13). (Refer to ASSEMBLY OF STEERING CYLINDER on W3-5-48.)
36. Add gear oil to drive housing (6) and planetary carriers (44) in the left and right sides. Install plugs (4) (2 used) and O-rings (5) (2 used) to drive housing (6). Install plug (45) and O-ring (46) to planetary carriers (44) in the left and right sides.
  -  : 14 mm
  -  : 50 N·m (5 kgf·m, 37 lbf·ft)

## UNDERCARRIAGE / Axle

### Assembly of Rear Axle

1. Install differential (55) to drive housing (5).

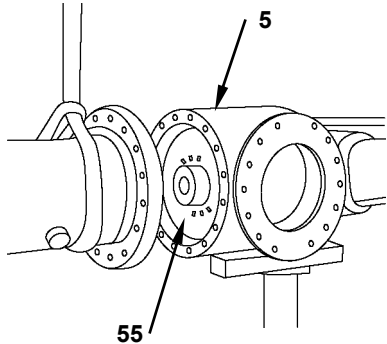



2. Install O-ring (2), shim (3) and roller bearing (4) to axle casing (1).



**CAUTION: Axle casing (1) weight:**  
**ZX210W-3: 108 kg (240 lb)**  
**ZX220W-3: 122 kg (270 lb)**

3. Attach a nylon sling onto axle casing (1). Hoist axle casing (1). Install axle casing (1) to drive housing (5) with bolts (12) (16 used) and washers (11) (16 used).

 : 27 mm

 : 300 N·m (30 kgf·m, 220 lbf·ft)

4. Install axle shaft (8) to axle casing (1).



**CAUTION: Knuckle (14) weight: 34 kg (75 lb)**

5. Install O-ring (13) to knuckle (14). Hoist knuckle (14). Install knuckle (14) to the rear axle with bolts (7) (14 used) and washers (6) (14 used).

 : 24 mm

 : 210 N·m (21 kgf·m, 155 lbf·ft)

6. Install the inner race of bearing (21) and bushing (23) to knuckle (14).

**IMPORTANT: When installing shaft seal (20), check the mounting position and dimension A. Install shaft seal (20) with the marking of OUT-SIDE facing upward and outward.**

7. Apply LOCTITE #574 onto the shaft seal (20) contact surface on hub carrier (22). Install shaft seal (20) to hub carrier (22).

 **NOTE: Dimension A: 0 to 0.3 mm (0 to 0.01 in)**

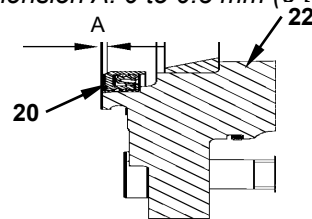

8. Install the outer race of bearing (21) and bearing (24) to hub carrier (22).

9. Apply hydraulic oil onto O-ring (19). Install O-rings (19, 54) and disc carrier (53) to knuckle (14).

10. Install ring gear (42) to knuckle (14).

11. Install washer (16) to sun gear shaft (18).

## UNDERCARRIAGE / Axle

### Disassembly of Steering Cylinder

1. Remove nut (21). Remove tie rod (3) from axle casing (1).

 : 41 mm

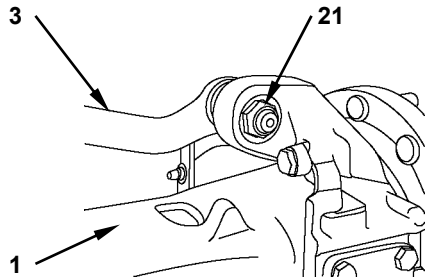

WCGB-03-05-017

2. Warm up the connection part of piston rod (4) and tie rod (3) by using a drier. Attach a spanner onto the connection part. Remove tie rod (3) from piston rod (4).

 : 46 mm

3. Remove other tie rod (3) in the same way as steps 1 to 2.

4. Remove elbows (22) (2 used) from drive housing (2).

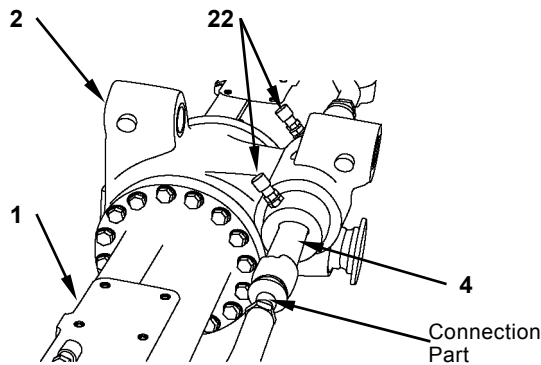

WCGB-03-05-018

5. Remove bolts (20) (5 used). Warm up the connection part of the piston rod (4) assembly and drive housing (2) by using a drier.

6. Tap and remove the piston rod (4) assembly from drive housing (2) by using a plastic hammer.

7. Remove bolts (20) (5 used). Remove flange (15) and retaining ring (14) from the piston rod (4) assembly.

8. Remove retaining ring (5) from the piston rod (4) assembly. Tap piston (10) to the position where O-ring (8) can be removed by using a plastic hammer. Remove O-ring (8) from the piston rod (4) assembly.

9. Remove rod (11) and piston (10) from cylinder tube (16). Remove piston (10) from rod (11).

10. Remove U-ring (13) and wiper ring (12) from cylinder tube (16).

11. Remove U-ring (6), wiper ring (7), guide rings (9, 17, 18) and seal (19) from piston (10) and rod (11).

## UNDERCARRIAGE / Operate Check Valve

### REMOVAL AND INSTALLATION OF OPERATE CHECK VALVE (FOR AXEL LOCK CYLINDER)



**CAUTION:** Bleed air from the hydraulic oil tank before doing any work. (Refer to **BLEED AIR FROM HYDRAULIC OIL TANK** on W1-4-1.)

#### Removal

1. Disconnect hoses (1) (2 used) from operate check valve (3). Cap the open ends.

 : 19 mm

2. Remove socket bolts (2) (4 used) from operate check valve (3). Remove operate check valve (3) and O-ring (4) from axle lock cylinder (5). Cap the open ends.

 : 6 mm

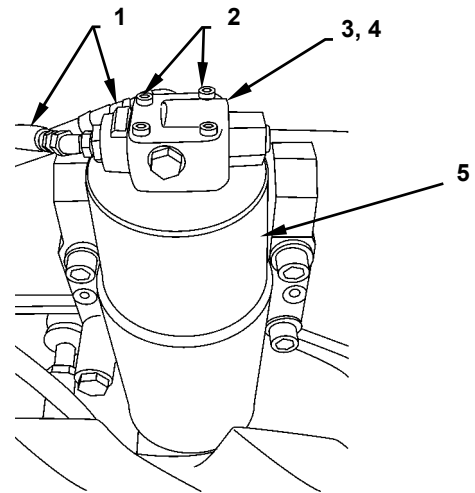



WCEB-03-06-001

#### Installation

1. Apply grease onto O-ring (4). Install O-ring (4) to operate check valve (3).

2. Install operate check valve (3) to axle lock cylinder (5) with socket bolts (2) (4 used).

 : 6 mm

 : 29.4 to 34.3 N·m  
(3 to 3.5 kgf·m, 22 to 25 lbf·ft)

3. Connect hoses (1) (2 used) to operate check valve (3).

 : 19 mm

 : 29.5 N·m (3 kgf·m, 22 lbf·ft)

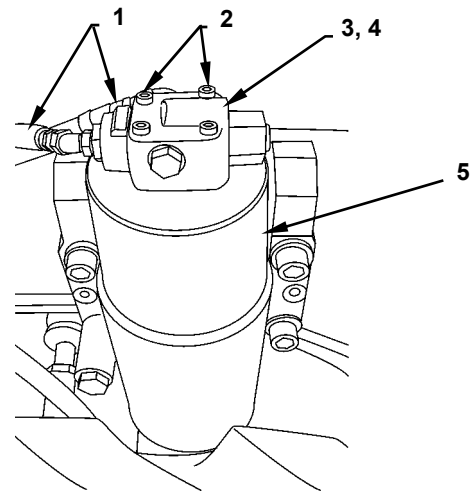

WCEB-03-06-001

---

## LOWERSTRUCTURE / Propeller Shaft

---

### Removal

1. Remove grease fitting (15) from propeller shaft (3).

 : 10 mm

**IMPORTANT: Propeller shaft (3) cannot be removed individually. If removing propeller shaft (3) individually, spline seal (14) is damaged. Remove the propeller shaft (3) assembly.**

2. Remove nuts (2) (8 used) from the flange part of propeller shaft (3).

 : 14 mm

3. Insert a pry bar between flange (1) and the flange part of propeller shaft (3). Pry propeller shaft (3) toward fork (16) and place propeller shaft (3) on the ground.

4. Remove socket bolts (4) (4 used) from the flange part of propeller shaft (3). Remove propeller shaft (3) from flange (7).

 : 8 mm

5. Remove nuts (9) (8 used) from the flange part of propeller shaft (8).

 : 14 mm

6. Remove sems bolts (5) (2 used) from bracket (6). Place bearing assembly (11) onto bracket (6).

 : 17 mm

7. Move propeller shaft (8) toward bracket (6) side. Pull out propeller shaft (8).

**IMPORTANT: Do not remove bearing assembly (11) unless necessary. When removing bearing assembly (11), follow the procedure below. Dispose removed bearing assembly (11).**

8. Remove nut (13) from propeller shaft (8). Remove yoke (12) from propeller shaft (8).

 : 32 mm

9. Remove bearing assembly (11) from propeller shaft (8).

## FRONT ATTACHMENT / Front Attachment

4. Place the tube end of boom cylinder (3) on a stand of 1 m (39 in) height.  
Start the engine. Operate the boom lever and retract boom cylinder (3). In order not to extend the rod, pass a wire through the rod hole and secure the rod to the cylinder tube.  
Stop the engine.
5. Remove boom cylinder (3) from the boom.  
Refer to Removal of Boom Cylinder on W4-2-10.
6. Remove other boom cylinder (3) in the same way as steps 3, 4 and 5.

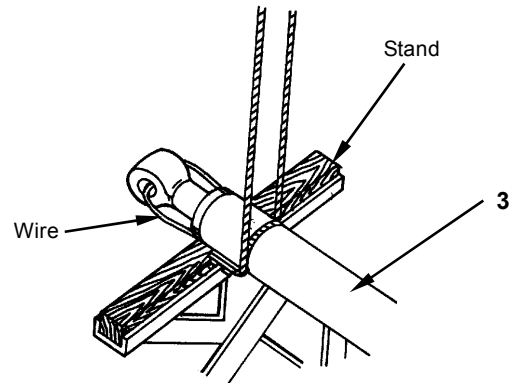

W554-02-03-007

**⚠ CAUTION:** Do not stand toward the removal direction of the pins as the pins may fly off suddenly.

7. Slowly tap and remove pin (6) by using a bar and a hammer. Remove thrust plate (2).
8. After stopping the engine, push the air bleed valve. Bleed air from the hydraulic oil tank and remove the cap.  
Release the pressure in the hydraulic circuit.  
Refer to HYDRAULIC CIRCUIT PRESSURE RELEASE PROCEDURE on W4-1-1.

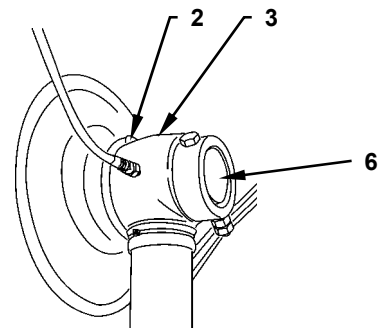

WCGB-04-01-002

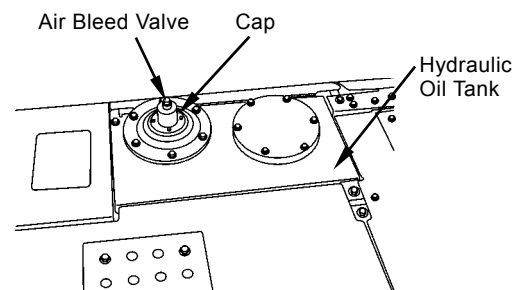

WCJB-01-04-002

9. Disconnect hoses (8) (6 used), (9) (4 used) (2) from the bucket cylinder and the arm cylinder.  
Cap the disconnected hoses and pipings.  
🔧 : 19 mm, 27 mm, 36 mm, 41 mm

**📝 NOTE:** The number of the hoses may differ depending on the front attachment specifications.

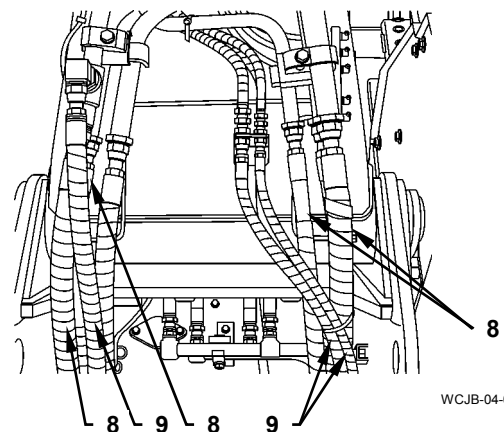

WCJB-04-01-001

## FRONT ATTACHMENT / Front Attachment

				Unit: mm (in)
	Part Name	Standard	Allowable Limit	Remedy
G	Pin	71 (2.8)	70.0 (2.9)	Replace
	Boss (Arm)	71 (2.8)	72.5 (2.9)	
	Bushing (Bucket Cylinder)	71 (2.8)	72.5 (2.9)	
H	Pin	80 (3.1)	79.0 (3.1)	
	Bushing	80 (3.1)	81.5 (3.2)	
	Bushing (Bucket Cylinder)	80 (3.1)	81.5 (3.2)	
I	Pin	71 (2.8)	70.0 (2.9)	
	Bushing	71 (2.8)	72.5 (2.9)	
J	Pin	80 (3.1)	79.0 (3.1)	
	Bushing	80 (3.1)	81.5 (3.2)	
K	Pin	80 (3.1)	79.0 (3.1)	
	Bushing	80 (3.1)	81.5 (3.2)	
L	Pin	100 (3.9)	99.0 (3.9)	
	Bushing	100 (3.9)	101.5 (4.0)	
M	Pin	100 (3.9)	99.0 (3.9)	
	Bushing	100 (3.9)	101.5 (4.0)	

**IMPORTANT:** When replacing HN bushing for the front attachment, install it by using a press and special tool (ST 1454).

## FRONT ATTACHMENT / Cylinder

6. Disconnect pipings (11) (2 used) at the bottom of arm cylinder (1). Cap the open ends. (When a hose rupture valve is provided, refer to REMOVAL AND INSTALLATION OF HOSE RUPTURE VALVE on W4-3-1.)

 : 36 mm, 41 mm

7. Disconnect lubrication hose (12) from arm cylinder (1).

 : 17 mm



**CAUTION: Arm cylinder (1) weight: 255 kg (570 lb)**

8. Attach a nylon sling at the center of gravity of arm cylinder (1). Hoist and hold arm cylinder (1).



**CAUTION: Metal fragments may fly off when a hammer is used. Wear necessary protection, such as goggles, hard hats, etc in order to prevent personal injury.**

9. Remove nuts (15) (2 used) and bolt (17) from the tube side in arm cylinder (1). Remove pin (14). Remove thrust plate (13). Hoist and remove arm cylinder (1).

 : 30 mm

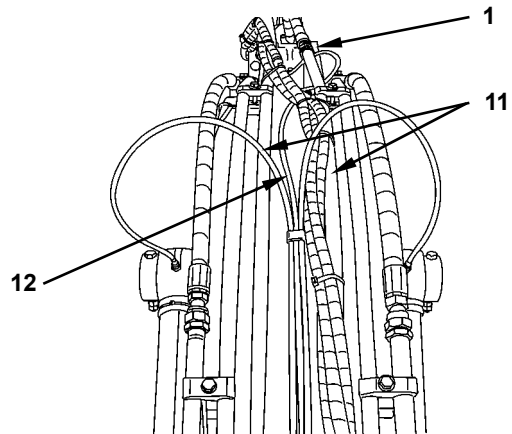

WCGB-04-01-001

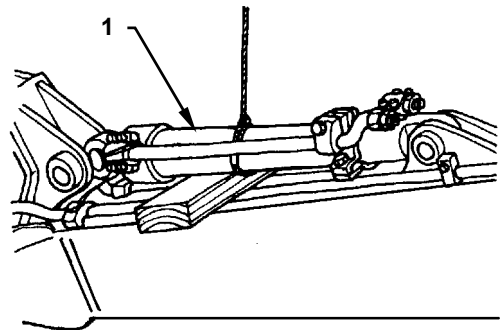



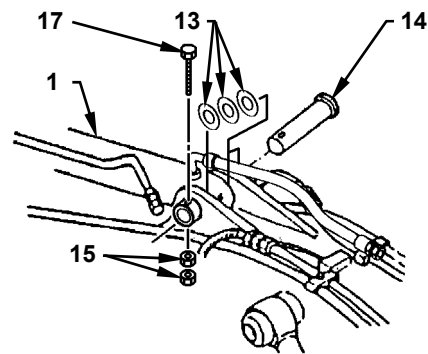



W102-04-02-016



W187-04-02-007

## FRONT ATTACHMENT / Cylinder

4. Start the engine and extend positioning cylinder (3). Align the rod hole of positioning cylinder (3) with the hole of the second boom. Insert thrust plate (5) and install pin (4) by tapping.
5. Align the pin holes of stopper (4) and pin (2). Install bolt (6) and nuts (7) (2 used).
  -  : 30 mm
  -  : 550 N·m (56 kgf·m, 410 lbf·ft)
6. Connect lubrication hose (1) to positioning cylinder (3).
  -  : 17 mm
  -  : 24.5 N·m (2.5 kgf·m, 18 lbf·ft)
  -  : 19 mm
  -  : 29.5 N·m (3 kgf·m, 22 lbf·ft)

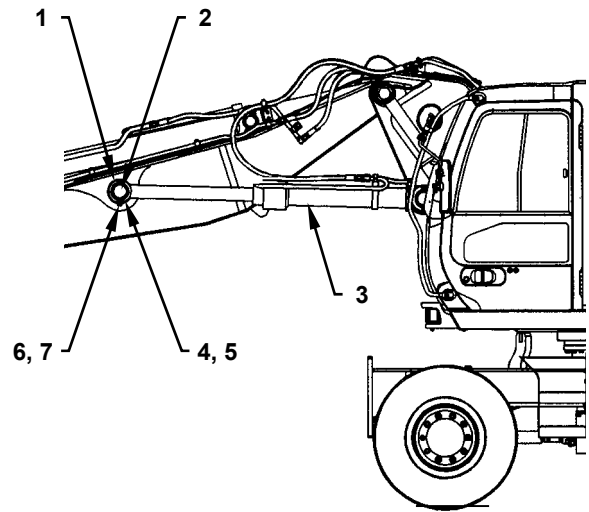

**IMPORTANT:** When completing the work, operate positioning cylinder (3) to the stroke end several times and bleed air from the circuit.

W1GL-04-01-008

# FRONT ATTACHMENT / Cylinder

## Bucket Cylinder

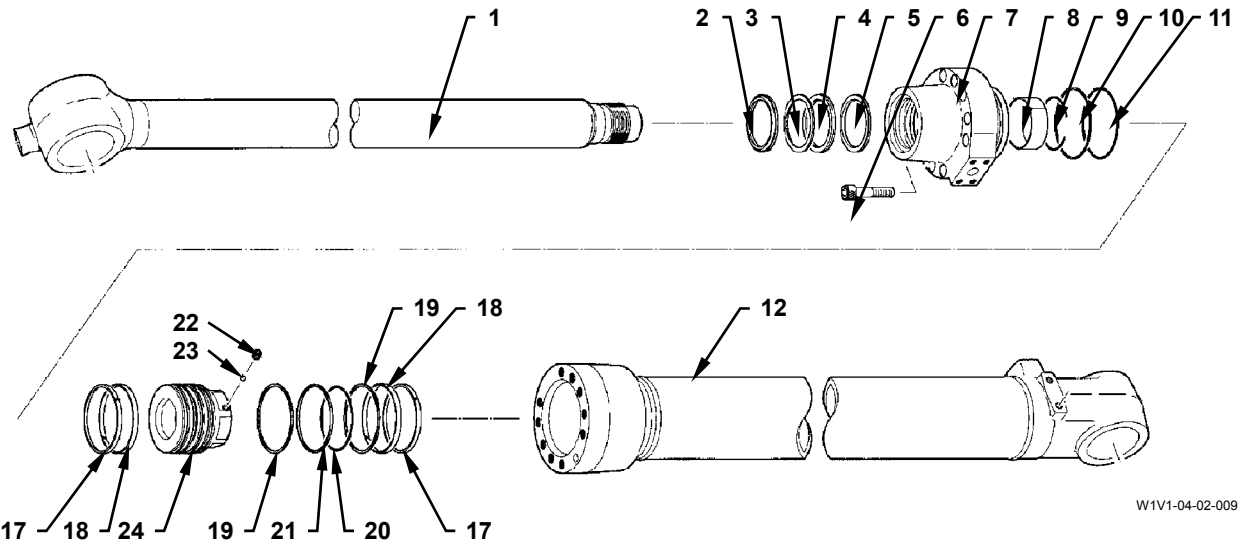

W1V1-04-02-009

- |                           |                       |                           |                      |
|---------------------------|-----------------------|---------------------------|----------------------|
| 1 - Piston Rod            | 8 - Bushing           | 15 - Cushion Seal         | 21 - Seal Ring       |
| 2 - Wiper Ring            | 9 - Snap Ring         | 16 - Snap Ring            | 22 - Set Screw       |
| 3 - Backup Ring           | 10 - Backup Ring      | 17 - Slide Ring (2 Used)  | 23 - Steel Ball      |
| 4 - U-Ring                | 11 - O-Ring           | 18 - Slide Ring (2 Used)  | 24 - Piston Nut      |
| 5 - Buffer Ring           | 12 - Cylinder Tube    | 19 - Backup Ring (2 Used) | 25 - Cushion Bearing |
| 6 - Socket Bolt (12 Used) | 13 - Stopper (2 Used) | 20 - O-Ring               | 26 - Cushion Seal    |
| 7 - Cylinder Head         | 14 - Cushion Bearing  |                           |                      |

## FRONT ATTACHMENT / Cylinder

**IMPORTANT: Face the slit in cushion seal (26) to the piston nut (24) side. Check the direction of the oil groove in cushion bearing (25).**

9. Install cushion seal (26) and cushion bearing (25) to piston rod (1).  
(Cushion bearing (25) and cushion seal (26) are not equipped for the bucket cylinder.)

10. Align the matching marks and tighten piston nut (24) by using special tool (ST 5908) and the special tool.

Special tool (outer diameter at nut part):

Bucket cylinder: (ST 3244: 90 mm)

 : 5600 N·m (570 kgf·m, 4130 lbf·ft)

Boom cylinder:

Monoblock boom: (ST 3245: 95 mm)

 : 5340 N·m (545 kgf·m, 3940 lbf·ft)

2-piece boom: (ST 3245: 95 mm)

 : 6000 N·m (610 kgf·m, 4430 lbf·ft)

Arm cylinder:

Monoblock boom: (ST 3245: 95 mm)

 : 8860 N·m (900 kgf·m, 6540 lbf·ft)

2-piece boom: (ST 3245: 95 mm)

 : 7900 N·m (810 kgf·m, 5380 lbf·ft)

11. Install steel ball (23) to piston rod (1). Tighten with set screw (22). Crimp set screw (22) by using a punch at 2 places.

 : 6 mm

 : 57 N·m (5.8 kgf·m, 42 lbf·ft)



**CAUTION: Align the piston rod (1) assembly with the center of cylinder tube (12) and insert straight in order not to damage the rings.**

12. Secure cylinder tube (12) horizontally on a workbench. Insert the piston rod (1) assembly into cylinder tube (12).

13. Install cylinder head (7) to cylinder tube (12) with socket bolts (6) (12 used).

 : 14 mm

 : 265 N·m (27 kgf·m, 195 lbf·ft)

**IMPORTANT: When replacing the bushing from piston rod (1) or cylinder tube (12) by using a hammer, the bushing may be damaged. Use a press and special tool (ST 1454) when removing and installing the bushing.**

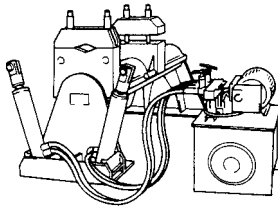



Special Tool: ST 5908

W158-04-02-022

## FRONT ATTACHMENT / Cylinder

### Disassembly of Outrigger and Blade Cylinders

 **NOTE:** The disassembling procedure starts on the premise that the hydraulic pipings and the bands securing the pipings have been removed.

 **CAUTION:** Outrigger cylinder weight: 90 kg (200 lb)  
Blade cylinder weight: 50 kg (110 lb)

1. Hoist the cylinder. Secure the cylinder horizontally on a workbench. Drain hydraulic oil from the cylinder.

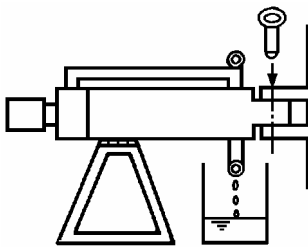

W102-04-02-027

2. Raise a detent (a part of cylinder tube (20)) in the groove on cylinder head (2). Pry and remove cylinder head (2) from cylinder tube (20) by using a pry bar.  
R wrench: (ST 3221)

 **CAUTION:** Do not drop piston rod (1) by tilting.

**IMPORTANT:** Remove piston rod (1) straight in order not to damage the rod surface.

3. Fully extend piston rod (1). Attach a nylon sling onto piston rod (1). Hold piston rod (1). Slowly remove piston rod (1) from cylinder tube (20). Set a cloth onto a wooden block. Place piston rod (1) horizontally on the wooden block.

4. Cut away the crimped part by using a hand drill and remove set screw (17) from piston nut (18).

 **NOTE:** Set screw (17) has been crimped by using a punch at 2 places after installing.

 : 4 mm

5. Remove piston nut (18) by using special tool (ST 3334). Remove piston (12) from piston rod (1) by using special tool (ST 3337).
6. Remove cylinder head (2) from piston rod (1).

**IMPORTANT:** When removing the seals, do not damage the parts.

7. Remove seal ring (13), wear ring (14), dust ring (15) and O-ring (16) from piston (12).
8. Remove retaining rings (3, 8), U-ring (5), dust seal (4) and backup ring (10) from the inside of cylinder head (2). Remove bushing (7) by using special tool (ST 2685).
9. Remove O-rings (9, 11) and backup ring (10) from the outside of cylinder head (2).

## FRONT ATTACHMENT / Hose Rupture Valve



---

### REMOVAL AND INSTALLATION OF HOSE RUPTURE VALVE FOR POSITIONING CYLINDER



**CAUTION:** Loosen the relief valve of hose rupture valve (8) slowly and release the pressure.



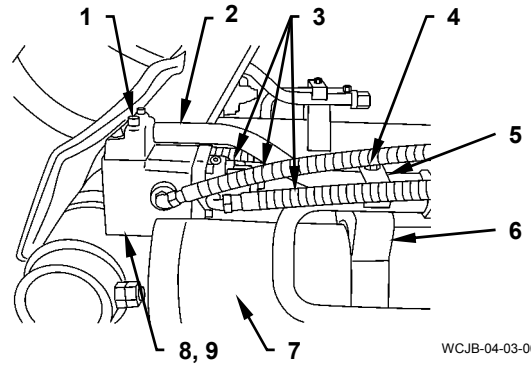

#### Removal

1. Remove bolts (4) (2 used) from clamp (5). Remove clamp (5) from bracket (6).  
 : 22 mm
2. Disconnect hoses (3) (3 used) from hose rupture valve (8). Cap the open ends. Attach an identification tag onto the disconnected hoses for assembling.  
 : 19 mm
3. Remove socket bolts (1) (4 used). Disconnect piping (2) from positioning cylinder (7). Remove hose rupture valve (8) and O-ring (9) from positioning cylinder (7). Cap the open ends.  
 : 10 mm



WCJB-04-03-003

## FRONT ATTACHMENT / Hose Rupture Valve

No.	Part Name	Q'ty	Wrench Size (mm)	Tightening Torque		Remark
				N-m	(kgf-m, lbf-ft)	
1	Spacer	1				
2	Plug	3	 : 5			
3	O-Ring	3				
4	Backup Ring	1				
5	O-Ring	1				
6	Orifice	2				
7	Backup Ring	2				
8	O-Ring	1				
9	Lock Nut	1	 : 17			
10	Poppet	1				
11	Set Screw	1	 : 6			
12	Spring	1				
13	O-Ring	1				
14	Washer	1				
15	Adapter	1	 : 24			
16	O-Ring	1				
17	Backup Ring	1				
18	O-Ring	1				
19	Casing	1				
20	O-Ring	1				
21	Plug	1	 : 32			
22	Stopper	1				
23	Spool	1				
24	Sleeve	1				
25	Backup Ring	1				
26	O-Ring	1				
27	O-Ring	3				
28	Plug	1				

CLICK HERE TO **DOWNLOAD** THE COMPLETE MANUAL

- Thank you very much for reading the preview of the manual.
- You can download the complete manual from: [www.heydownloads.com](http://www.heydownloads.com) by clicking the link below



- Please note: If there is no response to CLICKING the link, please download this PDF first and then click on it.

CLICK HERE TO **DOWNLOAD** THE COMPLETE MANUAL