

PART NO. W4FG-E-00

**HITACHI**

ZW80・90 WHEEL LOADER WORKSHOP MANUAL

# Workshop Manual

# ZW

# 80

# 90

# Wheel Loader

 **Hitachi Construction Machinery**

URL:<http://www.hitachi-c-m.com>

PRINTED IN JAPAN (K) 2010.06

Service Manual consists of the following separate Part No.

Technical Manual (Operational Principle) : Vol. No.TO4FG-E

Technical Manual (Troubleshooting) : Vol. No.TT4FG-E

Workshop Manual : Vol. No.W4FG-E

Axle Service Manual (ZX80) : Vol. No.KM-111174-E

Axle Service Manual (ZX90) : Vol. No.KM-112340-E

Reduction Device Service Manual : Vol. No.KM-31111214-E

CLICK HERE TO **DOWNLOAD** THE COMPLETE MANUAL

- Thank you very much for reading the preview of the manual.
- You can download the complete manual from: [www.heydownloads.com](http://www.heydownloads.com) by clicking the link below



- Please note: If there is no response to CLICKING the link, please download this PDF first and then click on it.

CLICK HERE TO **DOWNLOAD** THE COMPLETE MANUAL

# SAFETY

---

## MOVE AND OPERATE MACHINE SAFELY

- Bystanders can be run over.
  - Take extra care not to run over bystanders. Confirm the location of bystanders before moving, or operating the machine.
  - Always keep the travel alarm and horn in working condition (if equipped). It warns people when the machine starts to move.
  - Use a signal person when moving, swinging, or operating the machine in congested areas. Coordinate hand signals before starting the machine.
  - Use appropriate illumination. Check that all lights are operable before operating the machine. If any faulty illumination is present, immediately repair it.

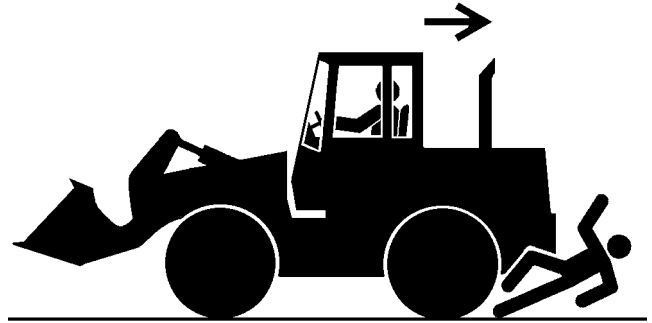

SA-398

011-E01A-0398

## HANDLE STARTING AIDS SAFELY

Starting fluid:

- Starting fluid is highly flammable.
  - Keep all sparks and flame away when using it.
  - Keep starting fluid well away from batteries and cables.
  - Remove container from machine if engine does not need starting fluid.
  - To prevent accidental discharge when storing a pressurized container, keep the cap on the container, and store it in a cool, well-protected location.
  - Do not incinerate or puncture a starting fluid container.



SA-293

036-E01A-0293-3

# SAFETY

---

## PRECAUTIONS FOR OPERATION

- If the front attachment or any part of the machine comes in contact with an overhead obstacle, both the machine and the overhead obstacle may become damaged, and personal injury may result.
  - Take care to avoid coming in contact with overhead obstacles with the bucket or arm during operation.

---

## PRECAUTIONS FOR LIGHTENING

- The machine is vulnerable to lightning strikes.
  - In the event of an electrical storm, immediately stop operation, and lower the bucket to the ground. Evacuate to a safe place far away from the machine.
  - After the electrical storm has passed, check all of the machine safety devices for any failure. If any failed safety devices are found, operate the machine only after repairing them.



SA-4EK-020

---

## OBJECT HANDLING

- If a lifted load should fall, any person nearby may be struck by the falling load or may be crushed underneath it, resulting in serious injury or death.

Never attach a sling or chain to bucket teeth or to the attachment (fork or grapple for example). They may come off, causing the load to fall.

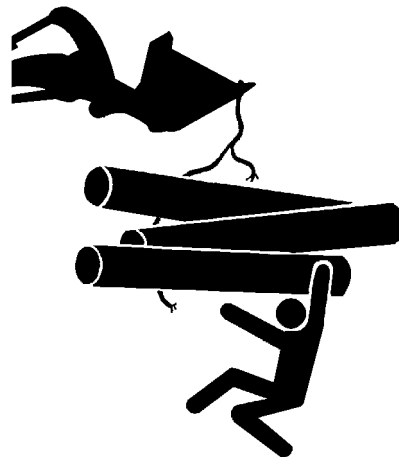

SA-132

## SAFETY

---

### EVACUATING IN CASE OF FIRE

- If a fire breaks out, evacuate the machine in the following way:
  - Stop the engine by turning the key switch to the OFF position if there is time.
  - Use a fire extinguisher if there is time.
  - Exit the machine.

518-E01A-0393



SA-393

### BEWARE OF EXHAUST FUMES

- Prevent asphyxiation. Engine exhaust fumes can cause sickness or death.
  - If you must operate in a building, be sure there is adequate ventilation. Either use an exhaust pipe extension to remove the exhaust fumes or open doors and windows to bring enough outside air into the area.

509-E01A-0016

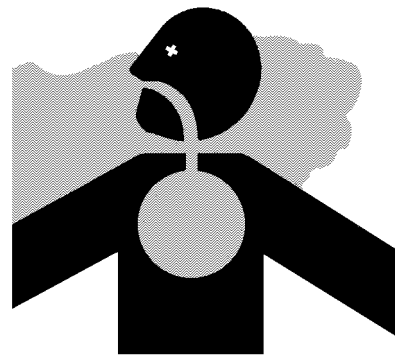

SA-016

### PRECAUTIONS FOR WELDING AND GRINDING

- Welding may generate gas and/or small fires.
  - Be sure to perform welding in a well ventilated and prepared area. Store flammable objects in a safe place before starting welding.
  - Only qualified personnel should perform welding. Never allow an unqualified person to perform welding.
- Grinding on the machine may create fire hazards. Store flammable objects in a safe place before starting grinding.
- After finishing welding and grinding, recheck that there are no abnormalities such as the area surrounding the welded area still smoldering.

523-E01A-0818

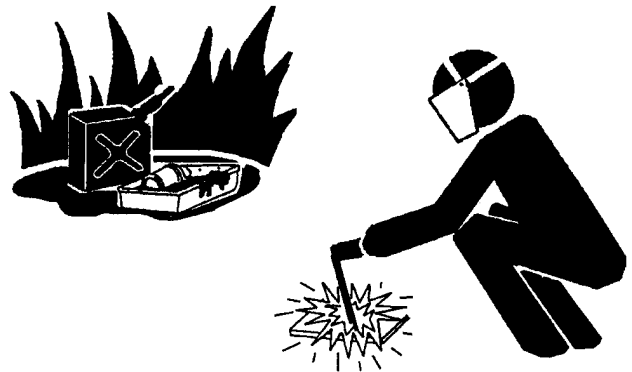

SA-818

# GENERAL / Precautions for Disassembling and Assembling

---

## DISASSEMBLY AND ASSEMBLY

### Precautions

- Clean the machine  
Thoroughly wash the machine before bringing it into the shop. Bringing a dirty machine into the shop may cause machine components to be contaminated during disassembling/assembling, resulting in damage to machine components, as well as decreased efficiency in service work.
  - Inspect the machine  
Be sure to thoroughly understand all disassembling/assembling procedures beforehand. It is helpful to avoid incorrect disassembling of components as well as personal injury. Check and record the items listed below. It is helpful to prevent problems from occurring in the future.
    - Model, serial No., hour meter symptoms, failed parts and causes
    - Clogging of filters, oil quality and quantity, and oil, water or air leaks, if any.
    - Damage or looseness of parts
  - Prepare and Clean Tools and Disassembly Area  
Prepare the necessary tools to be used and the area for disassembling work. Thoroughly clean the tools.
- Measure and record the degree of wear and clearances.

- Assembling
  - Be sure to clean all parts and inspect them for any damage. If any damage is found, repair or replace part.
  - Dirt or debris on the contact or sliding surfaces may shorten the service life of the machine. Take care not to contaminate any contact or sliding surfaces.
  - Apply a film of grease before installing. Apply new hydraulic oil or gear oil onto the sliding part in order to prevent seizure.
  - Be sure to replace O-rings, backup rings, and oil seals with new ones once they are disassembled.
  - Be sure that liquid-gasket-applied surfaces are clean and dry.
  - If an anti-corrosive agent has been used on a new part, be sure to thoroughly clean the part to remove the agent.
  - Utilize matching marks when assembling.
  - Be sure to use the designated tools to assemble bearings, bushings and oil seals.
  - Keep a record of the number of tools used for disassembly/assembly. After assembling is complete, count the number of tools, so as to make sure that no forgotten tools remain in the assembled machine.

### When Disassembling and Assembling

- Disassembling
  - In order to prevent dirt from entering, cap or plug the removed pipes.
  - Before disassembling, clean the exterior of the components. Place the components on a work bench.
  - Before disassembling, drain gear oil from the reduction gear.
  - Be sure to provide appropriate containers for draining fluids.
  - Put the matching marks in order not to confuse when reassembling.
  - Be sure to use the specified special tools, when instructed.
  - If a part or component cannot be removed after removing its securing nuts and bolts, do not attempt to remove it forcibly. Find the cause(s), then take the appropriate measures to remove it.
  - Orderly arrange disassembled parts. Mark and tag them as necessary.
  - Store common parts, such as bolts and nuts with reference to where they are to be used and in a manner that will prevent loss.
  - Inspect the contact or sliding surfaces of disassembled parts for abnormal wear, sticking, or other damage.

## GENERAL / Tightening

### TORQUE CHART



**CAUTION:** Use tools appropriate for the work to be done. Makeshift tools and procedures can create safety hazards. For loosening and tightening nuts and bolts, use correct size tools. Otherwise, tightening tools may slip, potentially causing personal injury.



#### Bolt Types

Tighten nuts or bolts correctly to torque specifications. Make sure to employ correct bolts and tighten them correctly when assembling the machine or components.

SA-040

#### Specified Tightening Torque

Bolt Dia. (mm)	Hexagon Wrench						Wrench Size mm
							
	Standard torque			Allowable torque range			
	N-m	kgf-m	lbf-ft	N-m	kgf-m	lbf-ft	
4	1.27	0.13	0.94	1.18 to 1.37	0.12 to 0.14	0.87 to 1	7
5	2.55	0.26	1.88	2.26 to 2.84	0.23 to 0.29	1.67 to 2.1	8
6	4.31	0.44	3.18	3.92 to 4.71	0.40 to 0.48	2.9 to 3.48	10
8	10.2	1.04	7.53	9.22 to 11.2	0.94 to 1.14	6.8 to 8.27	13
10	19.7	2.01	14.5	17.8 to 21.7	1.81 to 2.21	13.2 to 16	17
12	34.5	3.52	25.5	31.1 to 38.0	3.17 to 3.87	23 to 22.1	19
14	54.3	5.54	40.1	48.9 to 59.7	4.99 to 6.09	36.1 to 44.1	22
16	83.9	8.56	61.9	75.5 to 92.4	7.70 to 9.42	55.7 to 68.2	24
18	116	11.8	85.6	104 to 127	10.6 to 13.0	76.8 to 93.7	27
20	168	17.1	124	151 to 184	15.4 to 18.8	111 to 136	30
22	221	22.5	163	199 to 243	20.3 to 24.8	147 to 179	32
24	280	28.6	207	252 to 309	25.7 to 31.5	186 to 228	36
27	346	35.3	255	312 to 380	31.8 to 38.8	230 to 221	41
30	475	48.4	351	428 to 522	43.6 to 53.2	316 to 385	46

## GENERAL / Painting

### Painting

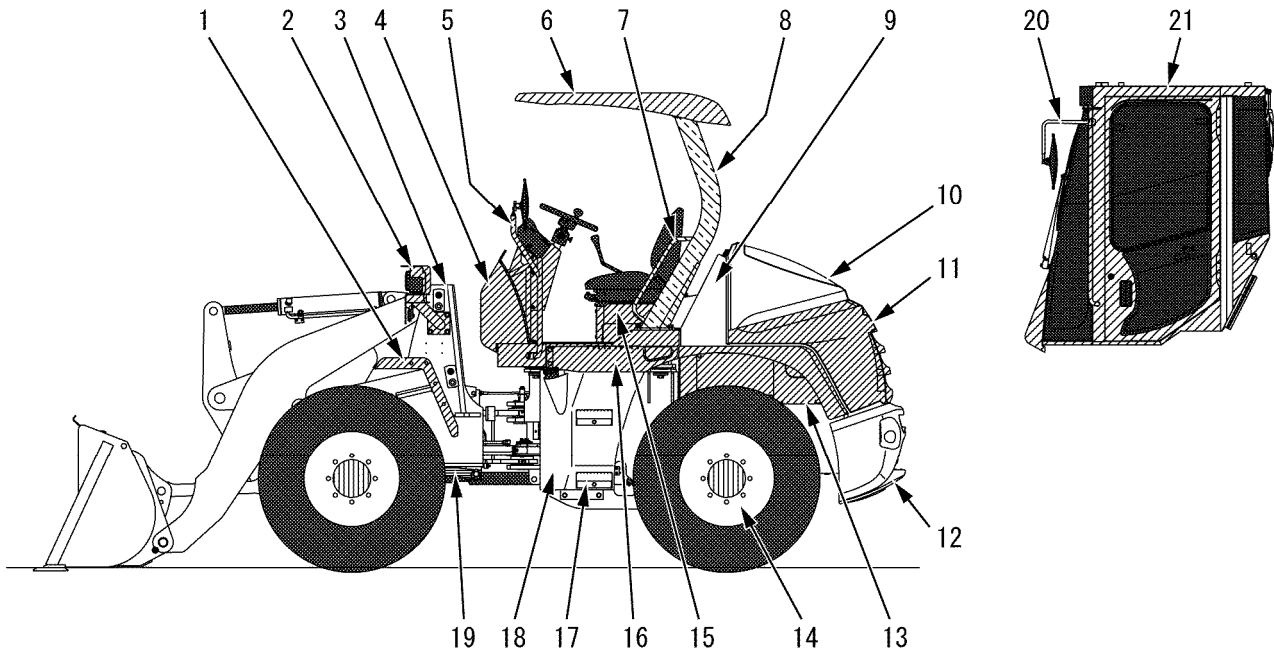

W4FG-01-03-001

	Painted Surface	Painting Color		Painted Surface	Painting Color
1	Front Fender	HG Beige Deep	12	Counterweight	TAXI Yellow
2	Light Bracket	HG Beige Deep	13	Rear Fender	HG Beige Deep
3	Body	TAXI Yellow	14	Rim	TAXI Yellow
4	Cowl Frame	HG Beige Deep	15	Seat Support	HG Beige Deep
5	Handrail	HG Beige Deep	16	Operator Frame	HG Beige Deep
6	Roof (Canopy) (*)	HG Beige Deep	17	Step	TAXI Yellow
7	Handrail (Canopy) (*)	HG Beige Deep	18	Oil Tank / Fuel Tank	TAXI Yellow
8	Support (Canopy)	Japan Paint Manufacturers Association YH-65	19	Articulation Lock Bar	Red
9	Hood Base	TAXI Yellow	20	Back Mirror Mounting Part	HG Beige Deep
10	Hood (Upper) (*)	TAXI Yellow	21	Cab	HG Beige Deep
11	Hood (Lower) (*)	HG Beige Deep			

(\*) Material is resin.

**IMPORTANT:** When cleaning the front attachment, cylinder, etc. fitted with HN bushing, take care not to pour washing liquid directly on the bushing. The ambient temperature should not exceed 70 °C when painting and drying.

## BODY / Canopy

### REMOVAL AND INSTALLATION OF FLOOR PLATE

#### Preparation

1. Park the machine on a level and solid surface. Stop the engine. Lower the bucket onto the ground horizontally.
2. Place wheel stoppers in front of and behind the wheels in order to secure the machine.
3. Install articulation lock bar (3) to the rear frame pin(1). Secure with link pin (2).

When removing and installing the floor plate, remove and install the following parts.

- Floor Inspection Cover
- Seat Support
- Front Console and Surroundings
- Right Console and Surroundings

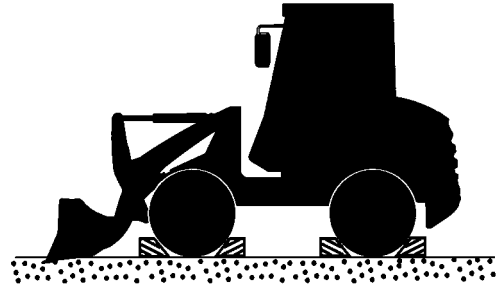

W4EK-03-04-001

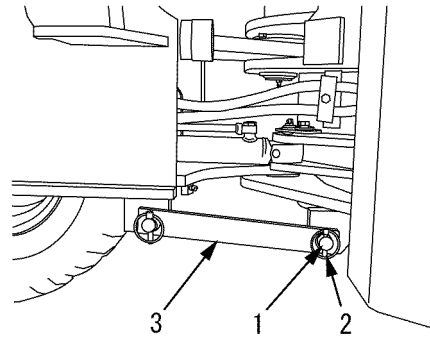

W4FG-02-01-001

## BODY / Canopy

### Installation of Right Console and Surroundings

1. Install right console box (8) to the floor plate with bolts (16) (4 used), spring washers (15) (4 used), and washers (14) (4 used).

 : 17 mm

2. Connect control cables (9, 10) with bolts (12) (2 used) and nuts (13) (2 used), which are attached to front attachment control lever (7).

3. Install key switch (7) to right console box (8).

4. Install cover (1) to right console box (8) with bolts (3) (4 used) and washers (2) (4 used). Install the cap part of key switch (7).

 : 5 mm

5. In case the heater switch (optional) is provided, connect connector (C) of harness (11).

6. Connect connector (B) of harness (11) to eco mode switch.

7. Install covers (6, 17) to right console box (8) with bolts (4) (7 used) and washers (5) (7 used).

 : 5 mm

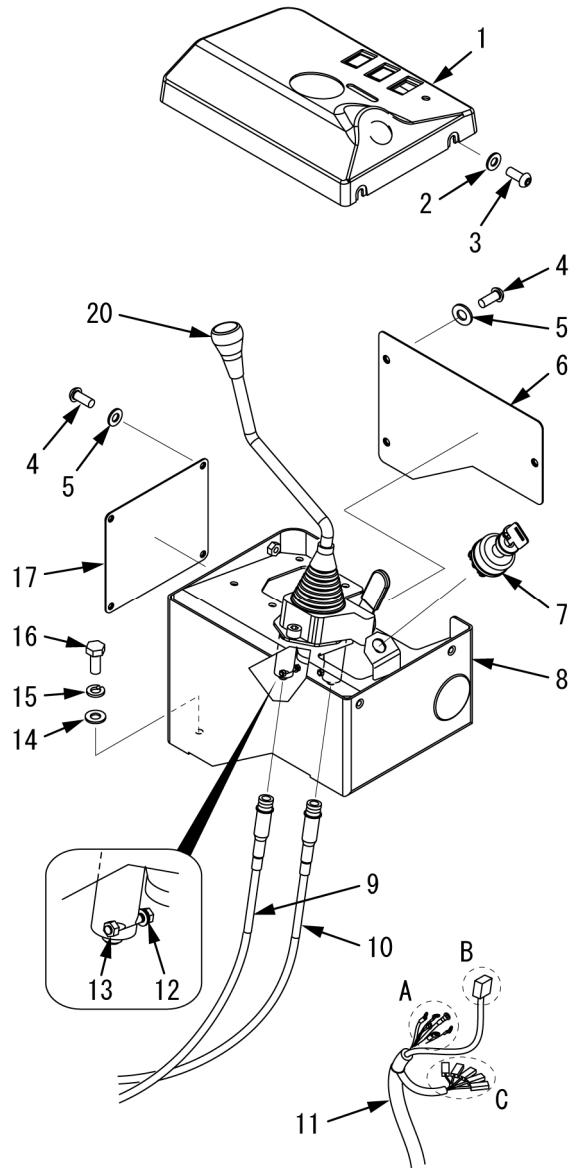

W4FG-02-01-011

## BODY / Cab

### Installation of Heater

1. Install heater (1) to heater support (7) with bolts and washers (2) (4 used).  
🔧 : 17 mm
2. Install heater support (7) to the seat support with bolts and washers (8) (4 used).  
🔧 : 17 mm
3. Connect hoses (9) (2 used) to heater (1) with hose clamps (10) (2 used).
4. Fully open the cock in valve (6) and turn to the OPEN position.
5. Connect connector (B) of heater harness (4). Connect ground line (12) of heater (1) to the rear frame with bolt (13).
6. Install defroster hoses (3) (2 used) to heater (1) with hose connectors (5) (2 used).

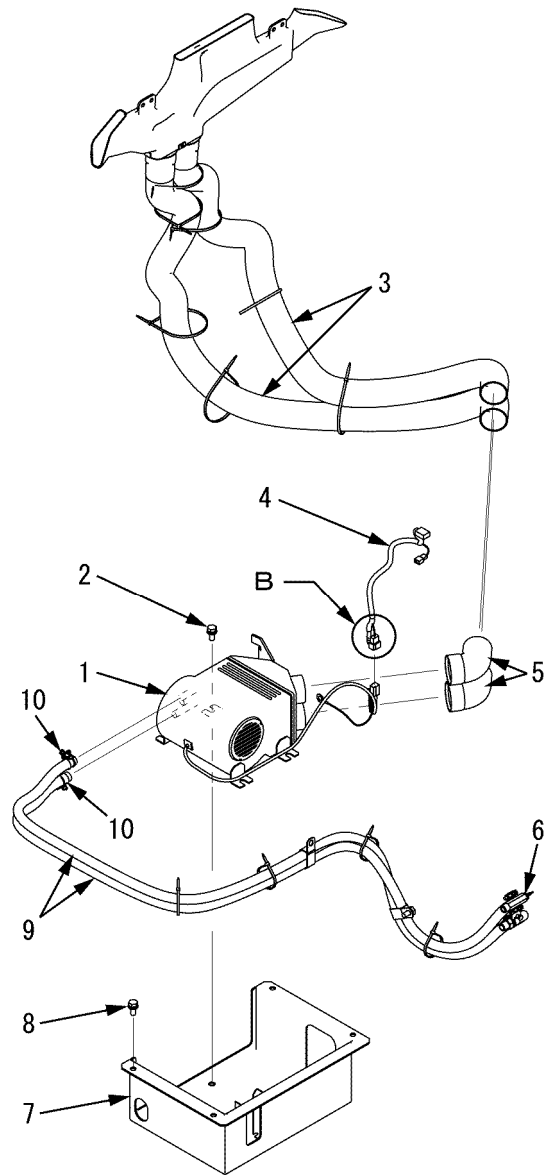

W4FG-02-02-006

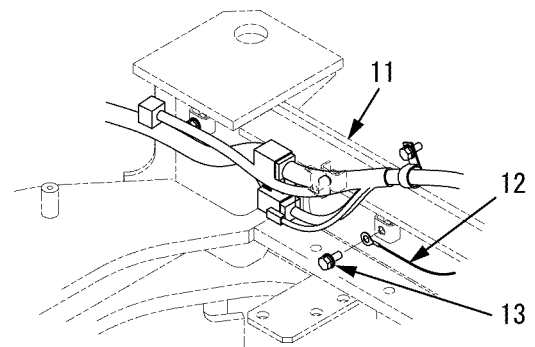

W4FG-02-02-007

## BODY / Center Hinge

---



**CAUTION:** The center hinge is required to disassemble for the major maintenance work such as removal of the front frame from the rear frame. At this time, move the machine into the factory.

### Preparation

1. When disassembling the center hinge, set the machine to the conditions as illustrated in the right.
2. Remove the canopy (or the cab) and the floor plate. (Refer to W2-1 or W2-2.)
3. Remove the front attachment. (Refer to W4-1 or W4-2.)
4. Remove the engine hood. (Refer to W2-5.)
5. Remove the counterweight. (Refer to W2-3.)
6. Remove the connecting parts between the front frame (11) and the rear frame (7).
  - Propeller Shaft (Refer to W3-4.)
  - Steering Cylinder (Refer to W3-8.)
  - Hydraulic Hose (between steering valve and control valve) (Refer to W2-8.)
  - Control Valve (Refer to W2-8.)
  - Harness
7. Support front frame (11) and rear frame (7) by using firm support stands (25, 26, and 27).

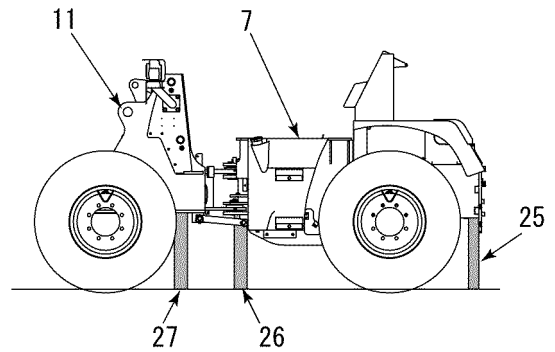

W4FG-02-04-004

## BODY / HST Pump and Main Pump

### REMOVAL AND INSTALLATION OF HST PUMP

#### Preparation

1. Park the machine on a level and solid surface. Stop the engine. Lower the bucket onto the ground horizontally.
2. Place wheel stoppers in front of and behind the wheels in order to secure the machine.
3. Install articulation lock bar (3) to rear frame pin (1). Secure with link pin (2).
4. Remove the canopy or the cab. (Refer to W2-1 or W2-2.)
5. Remove the floor plate. (Refer to W2-1.)

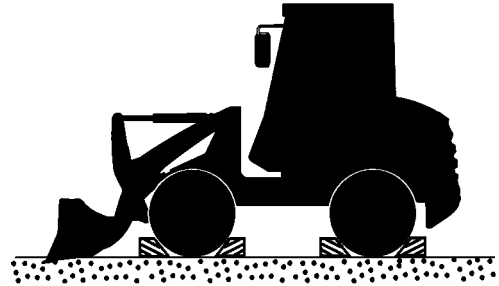

W4EK-03-04-001

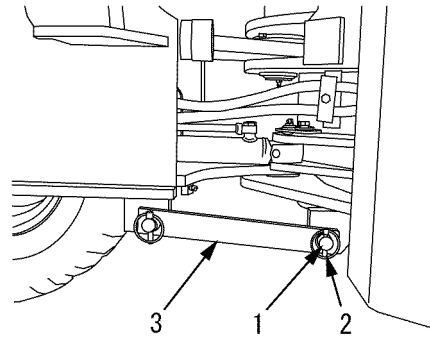

W4FG-02-01-001

## BODY / HST Pump and Main Pump

### Removal of Main Pump

1. Disconnect hose (11) from main pump (2). Cap the open ends. Attach an identification tag onto the disconnected hoses for assembling.  
🔧 : 27 mm, 36 mm
2. Remove bolts (7) (4 used) and spring washers (8) (4 used) from pipe (9). Remove tube (9) from main pump (2). Cap the open ends.  
🔧 : 17 mm
3. Remove O-ring (10) from tube (9).
4. Remove bolts (3) (2 used), spring washers (4) (2 used), and washers (5) (2 used) from main pump (2). Remove main pump (2) from HST pump (1).  
🔧 : 17 mm
5. Remove O-ring (6) from HST pump (1).
6. Remove coupling (12) from the connecting part of HST pump (1).

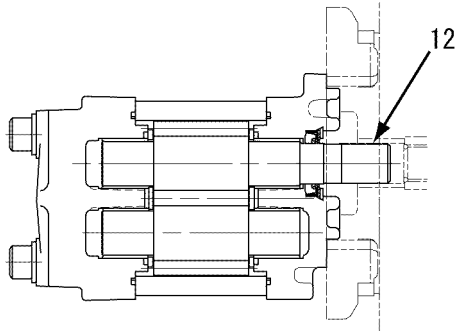

W4FG-02-06-008

### Installation of Main Pump

1. Install coupling (12) to the connecting part of HST pump (1).
2. Install O-ring (6) to HST pump (1).
3. Install main pump (2) to HST pump (1) with bolts (3) (2 used), spring washers (4) (2 used), and washers (5) (2 used).  
🔧 : 17 mm
4. Connect O-ring (10) to tube (9).
5. Install pipe (9) to main pump (2) with bolts (7) (4 used) and spring washers (8) (4 used).  
🔧 : 17 mm
6. Connect hose (11) to main pump (2).  
🔧 : 27 mm, 36 mm
7. Install the operator frame. (Refer to W2-1.)
8. Install the canopy or cab. (Refer to W2-1 or W2-2.)

CLICK HERE TO **DOWNLOAD** THE COMPLETE MANUAL

- Thank you very much for reading the preview of the manual.
- You can download the complete manual from: [www.heydownloads.com](http://www.heydownloads.com) by clicking the link below



- Please note: If there is no response to CLICKING the link, please download this PDF first and then click on it.

CLICK HERE TO **DOWNLOAD** THE COMPLETE MANUAL

## BODY / HST Motor

### DISASSEMBLY AND ASSEMBLY OF HST MOTOR

**IMPORTANT:** Do not disassemble HST motor without reason. When disassembling HST pump, minimize the essential removal. Surely record the dimensions of the adjusting parts such as adjusting screws before disassembling. Take great care and always pay special attention to return to the original dimensions when reassembling.

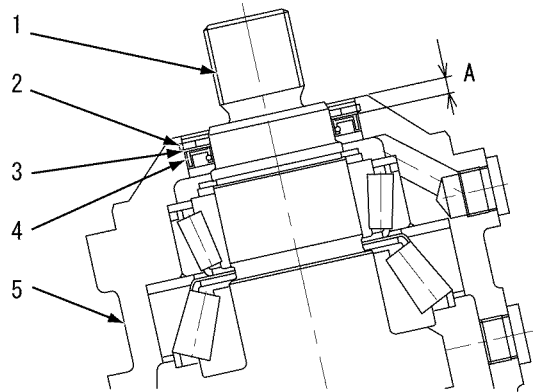

W4FG-02-07-006

#### Disassembly of HST Motor Connected Part (Reduction Side)

1. Place HST motor on a clean stand with the drive shaft (1) of HST motor facing upward.

 **NOTE:** Protect the spline part of drive shaft (1).

2. Remove retaining ring (2) from housing (5). Remove shim (3).
3. Evenly install tapping screw (6) (Nominal Diameter 3.5 mm×Length 25 mm) to the holes (2 places), which are blocked by the rubber of seal ring (4). Remove seal ring (4) by using a pair of pliers.

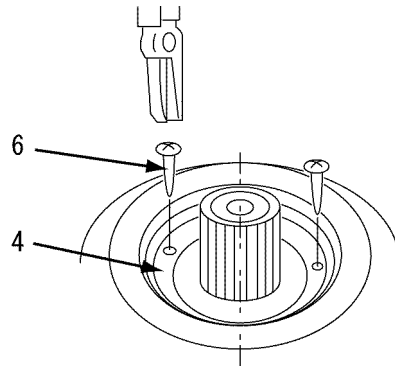

W4FG-02-07-007

**IMPORTANT:** Record installing depth (A) of seal ring (4).

#### Assembly of HST Motor Connected Part (Reduction Side)

1. Check for the installing depth (A) of seal ring (4). Install seal ring (4) to housing (5).
2. Install shim (3) to housing (5). Secure with retaining ring (2).

## BODY / Control Valve

### Removal



**CAUTION:** Attach an identification tag onto the disconnected hose and the pipe for assembling.

1. Remove bolts (24) (4 used). Remove cover (23) from front frame (18).

 : 17 mm

2. Disconnect connector (6) of the bucket auto leveler proximity switch harness.

3. Remove bolts (9) (2 used), spring washers (10) (2 used), washers (11) (2 used), bolt (12), washer (13), spring washer (15), and nut (16). Remove cover (14) from front frame (18).

 : 17 mm

4. Remove control cables (17) (2 used) from control valve (1).

 : 10 mm, 13 mm, 14 mm, 24 mm

5. Disconnect hoses (7, 8) from control valve (1). Cap the open ends.

 : 27 mm, 36 mm

6. Disconnect hoses (4, 5) from control valve (1). Cap the open ends.

 : 22 mm

7. Disconnect hoses (2, 3) from control valve (1). Cap the open ends.

 : 19 mm, 27 mm

8. Remove bolts (19) (3 used), washers (20) (3 used), spring washers (21) (3 used), and nuts (22) (3 used). Remove control valve (1) from front frame (18).

 : 17 mm

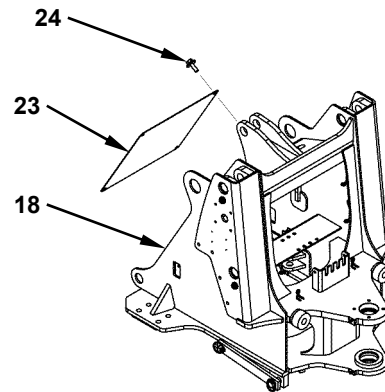

W4FG-02-08-003

## BODY / Control Valve

### Disassembly of Lift Arm Spool Assembly

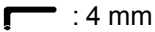
1. Remove O-rings (20), poppet (18) and spring (19) from housing (1).
2. Remove screws (21) (2 used) and seal plate (3) from housing (1).
3. Remove retaining ring (16) and spacer (15) from cap (7).
4. Remove socket bolts (22) (2 used) from cap (7). Remove cap (7) from housing (1). Remove sleeve (8) while pushing large steel ball (13) in pin (9) with screw driver (-).  
 : 4 mm
5. Slowly push back large steel ball (13). Remove large steel ball (13), small steel balls (14) (4 used) and spring (12) from pin (9).

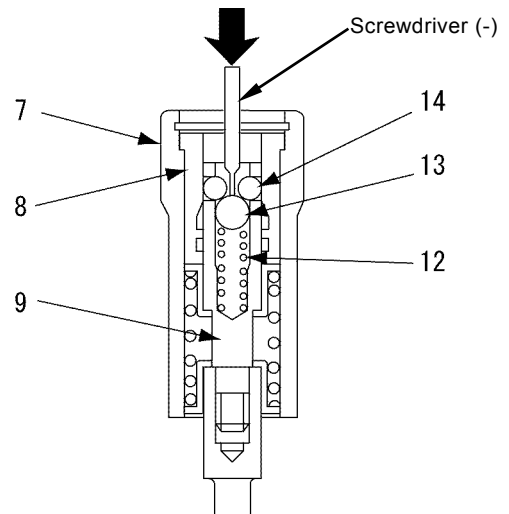

W4EK-02-08-011

 **NOTE:** Do not loose steel ball (13) and steel balls (14) (4 used) as the steel balls may fly out.

6. Remove pin (9) from spool (2). Remove spring seats (10) (2 used) and spring (11).
7. Remove spacer (6) from spool (2). Remove O-rings (4, 17) from spacer (6).
8. Remove spool (2) from housing (1).

 **NOTE:** For easy removal, rotate and remove spool (2).

9. Remove wiper ring (5) and O-ring (4) from housing (1).

## TRAVEL SYSTEM / Reduction Device

---

### REMOVAL AND INSTALLATION OF REDUCTION DEVICE

The reduction device and the rear axle are united into one part.

Remove the reduction device and the rear axle from the rear frame. (Refer to W3-3-7.)

As for assembly and disassembly of reduction device, refer to Reduction Device Service Manual (Part No, KM-3111214)

## TRAVEL SYSTEM / Axle

---

7. Remove the assembly of rear axle (15) and reduction device (12) from rear frame (16). Place the assembly of rear axle (15) and reduction device (12) on stand (11). Pull the assembly of rear axle (15), reduction device (12), and stand (11) out.
8. Remove reduction device (12) from rear axle (15). (Refer to Reduction Device Service Manual (Part No, KM-31111214))

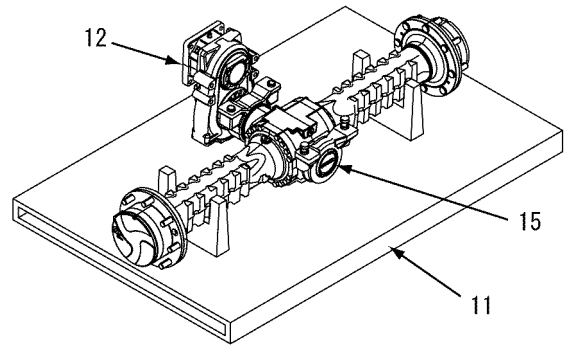



W4FG-03-03-008

## TRAVEL SYSTEM / Master Cylinder

### Installation

1. Install nut (9) and yoke (11) to master cylinder (1).

 : 17 mm

 : 23 to 28 N·m

(2.3 to 2.9 kgf·m, 17 to 21 lbf·ft)

2. Install master cylinder (1) to steering support (5) with bolts (8) (2 used), spring washers (7) (2 used) and nuts (6) (2 used).

 : 17 mm

 : 44 to 54 N·m

(4.5 to 5.5 kgf·m, 32 to 40 lbf·ft)

3. Connect hose (4) to master cylinder (1).

 : 17 mm, 19 mm

 : 44 N·m (4.5 kgf·m, 32 lbf·ft)

4. Connect hose (3) to master cylinder (1) with hose clamp (2).

 : 3.4 N·m (0.35 kgf·m, 2.51 lbf·ft)

5. Fit yoke (11) with the mounting hole on brake pedal (14) and install yoke (11) with pin (10), washer (12) and snap pin (13).

6. After completing the work, adjust the parts (Refer to Installation Standard on W3-5-4.)

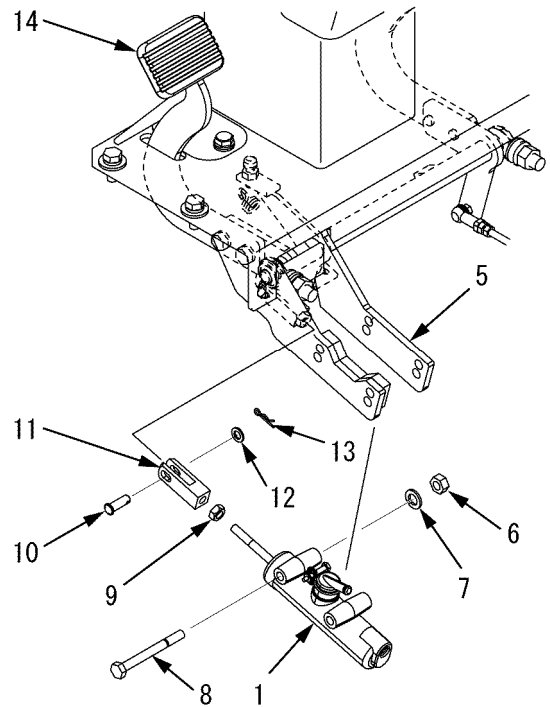

W4FG-03-05-002

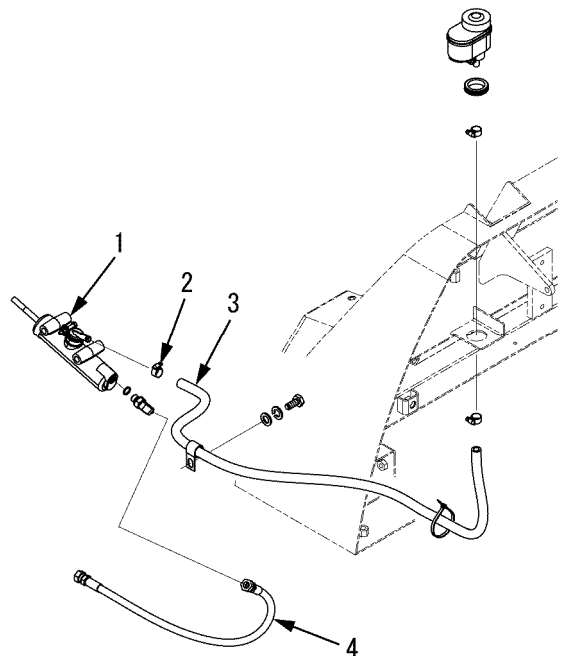



W4FG-03-05-001

## TRAVEL SYSTEM / Parking Brake Solenoid

### Installation

1. Install parking brake solenoid (1) to plate (6) with bolts (11) (2 used) and spring washers (10) (2 used).

 : 10 mm

 : 9.2 to 11.1 N·m  
(0.94 to 1.14 kgf·m, 6.79 to 8.19 lbf·ft)

2. Install plate (6) with parking brake solenoid (1) to rear frame (5) with bolts (9) (2 used), spring washers (8) (2 used) and washers (7) (2 used).

 : 17 mm

3. Connect hoses (2, 3 and 4) to parking brake solenoid (1).

 : 17 mm, 19 mm

4. Connect connector of the parking brake solenoid (1) harness.

5. Install the inspection cover. (Refer to W2-1-7.)

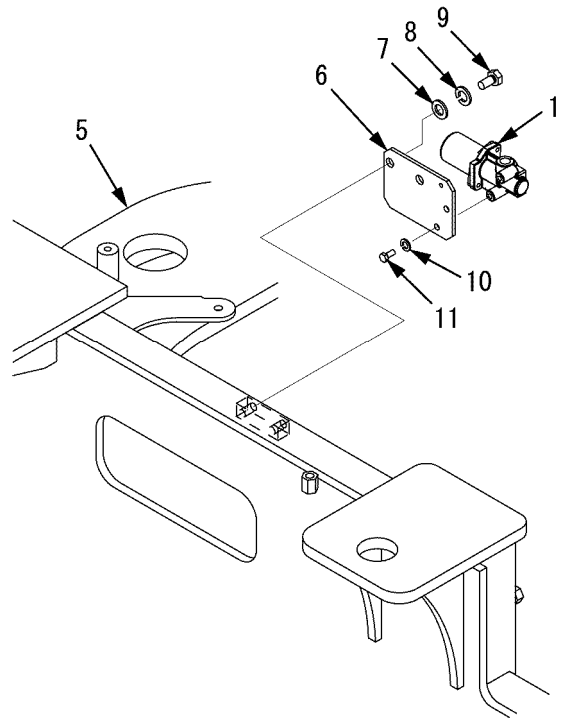

W4FG-03-06-002

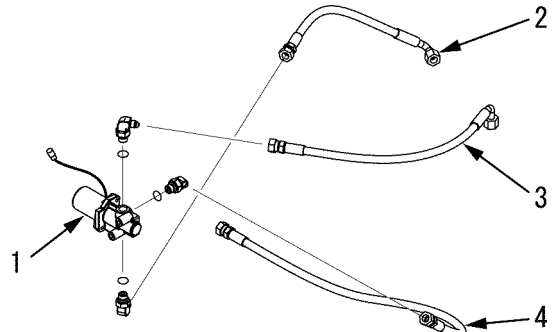

W4FG-03-06-001

## TRAVEL SYSTEM / Steering Valve

6. Rotate spool and sleeve assembly (02), and set pin (13) and the port surface of housing (1) in parallel. Push spool and sleeve assembly (2) from the cap (7) side. Remove bushing (20) from housing (1).
7. Remove oil seal (16) and dust seal (19) from bushing (20).

 **NOTE:** Do not damage bushing (20) when removing oil seal (16).

8. Remove bearing races (14) (2 used) and thrust needle (15) from spool and sleeve assembly (2).
9. Remove spool and sleeve assembly (2) from housing (1).

 **NOTE:** Remove spool and sleeve assembly (2) from housing (1) by rotating in order not to get sleeve (2B) caught in housing (1).

10. Remove pin (13) from spool and sleeve assembly (2).

 **NOTE:** Put the matching marks onto spool (2A) and sleeve (2B) by using an oil-based pen before removing pin (7).

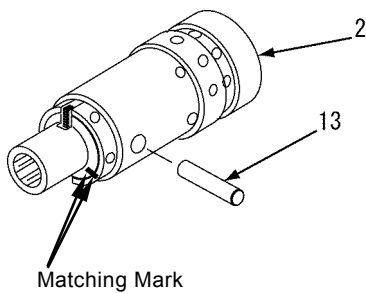

W4FG-03-07-010

**IMPORTANT:** Wear a pair of protective glasses as center spring (18) and flat spring (17) may fly out.

11. Push spool (2A) in sleeve (2B) forward. Remove center springs (18) (4 used) and flat springs (17) (2 used) from spool (2A).

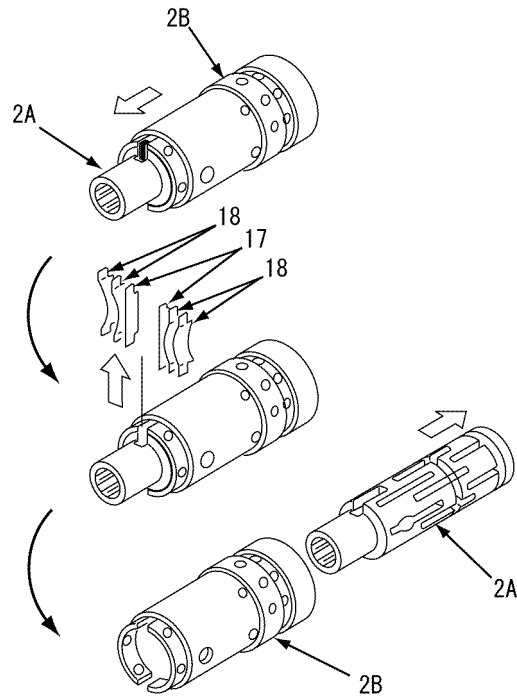





W4FG-03-07-009

12. Remove spool (2A) from sleeve (2B) by rotating.
13. Remove O-ring (3) from housing (1).

## TRAVEL SYSTEM / Steering Cylinder

### Removal

1. Remove bolts (20) (4 used) from cover (21).  
Remove cover (22) from front frame (1).  
 : 17 mm
2. Disconnect hoses (17, 18) from steering cylinder (9). Disconnect hoses (19) (2 used) from steering cylinder (9, 20). Cap the open ends.  
 : 19 mm, 22 mm
3. Disconnect remote lubrication pipings (8, 10).  
 : 17 mm
4. Remove bolts (16) (2 used), spring washers (15) (2 used) and washers (14) (2 used) from pins (13) (2 used). Remove pin (13) from front frame (1).  
 : 17 mm
5. Remove bolts (2) (2 used), spring washers (3) (2 used) and washers (4) (2 used) from pins (5) (2 used). Remove pins (5) (2 used) from the rear frame. Remove shims (9, 20) (2 used for each).  
 : 17 mm
6. Remove steering cylinders (9, 20) from front frame (1) and the rear frame.

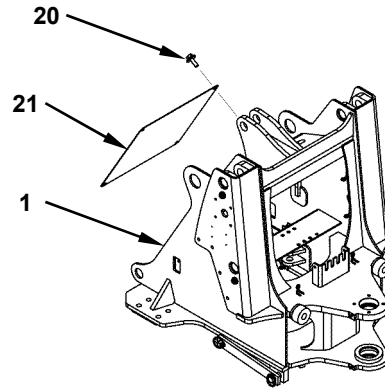

W4FG-03-08-015

## TRAVEL SYSTEM / Steering Cylinder

7. Adjust seal ring (3-1) of extended seal ring assembly (3) by using special tool (C).

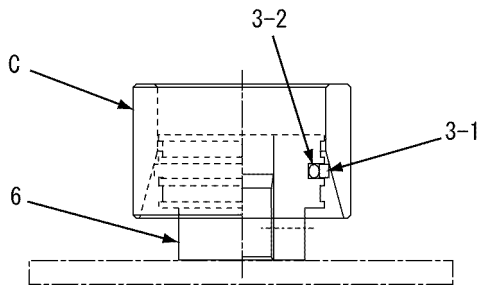

W4FG-03-08-010

**IMPORTANT: When installing slide rings (2, 7), do not set the slit positions at the same place.**

8. Install slide rings (2, 7) to the seal grooves on both sides of piston (6).
9. Secure piston rod (16) on a workbench horizontally.
10. Apply a small amount of hydraulic oil onto the piston rod (16) surface. Install cylinder head (14) to piston rod (16).
11. Apply hydraulic oil onto the thread part of the piston (6) bore part. Install piston (6) to piston rod (16).  
(ZW80)  
🔧 : 27 mm  
🔩 : 184 N·m (18.8 kgf·m, 136 lbf·ft)  
(ZW90)  
🔧 : 30 mm  
🔩 : 206 N·m (21.0 kgf·m, 152 lbf·ft)
12. Insert steel ball (5) to the set screw mounting hole on piston (6). Install set screw (4) to piston (6). Crimp set screw (4) by using a punch (2 places).  
🔧 : 5 mm  
🔩 : 6.8 N·m (0.7 kgf·m, 5.0 lbf·ft)
13. Apply hydraulic oil onto the packing parts. Secure cylinder tube (1) in a vise horizontally. Insert piston rod (16) into cylinder tube (1).
14. Apply hydraulic oil onto the packing parts. Apply THREEBOND #1901 onto the thread part of cylinder tube (1). Tighten cylinder head (14) to cylinder tube (1) by using a hook wrench. Bend the lock washer in order not to loosen.  
(ZW80)  
🔩 : 235 N·m (23.9 kgf·m, 173 lbf·ft)  
(ZW90)  
🔩 : 255 N·m (26.0 kgf·m, 188 lbf·ft)

---

---

# SECTION 4

# ATTACHMENT

## — CONTENTS —

### **Group 1 Front Attachment**

Removal and Installation of  
Front Attachment..... W4-1-1

### **Group 2 Cylinder**

Removal and Installation of Cylinder ..... W4-2-1  
Disassembly of Lift Arm Cylinder ..... W4-2-6  
Assembly of Lift Arm Cylinder ..... W4-2-10  
Disassembly of Bucket Cylinder ..... W4-2-14  
Assembly of Bucket Cylinder ..... W4-2-18  
Maintenance Standard..... W4-2-22

## ATTACHMENT / Front Attachment

### Installation

**IMPORTANT:** Check for the outer and inner diameters, wear and damage of all pins and bushings before installation. If any damage is found, replace the parts.

**IMPORTANT:** When installing the pin, apply grease onto the inside of the bushing and the dust seal. Apply the rust-inhibiting oil onto the inside of the boss.

**IMPORTANT:** Install the bushing as illustrated in the right.

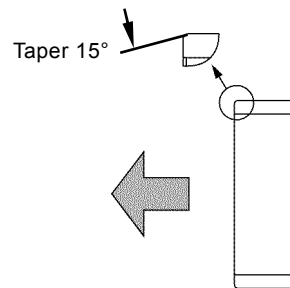

W4EK-04-01-010

**CAUTION:** Lift arm (21) weight: ZW80 : 300 kg (661 lb)  
ZW90 : 360 kg (794 lb)

1. Hoist and fit pin (19) in lift arm (20) with the pin hole on front frame (25).

**CAUTION:** Metal fragments may fly off when a hammer is used. Wear necessary protection, such as goggles, helmets, etc in order to prevent personal injury.

2. Install pins (24) (2 used) to front frame (25) with spring washers (22) (2 used), washers (23) (2 used) and bolts (21) (2 used).

 : 19 mm

3. Start the engine. Extend the piston rod of lift arm cylinder (31). Stop the engine.

4. Hoist lift arm (21). Fit the pin (29) holes on lift arm (20) and lift arm cylinder (31).

**CAUTION:** Metal fragments may fly off when a hammer is used. Wear necessary protection, such as goggles, helmets, etc in order to prevent personal injury.

5. Install shims (30) (4 used) to the pin (29) holes (2 places) on lift arm (20). Install pins (29) (2 used) to lift arm cylinder (31) (2 used) with washers (28) (2 used), spring washers (27) (2 used) and bolts (26) (2 used).

 : 19 mm

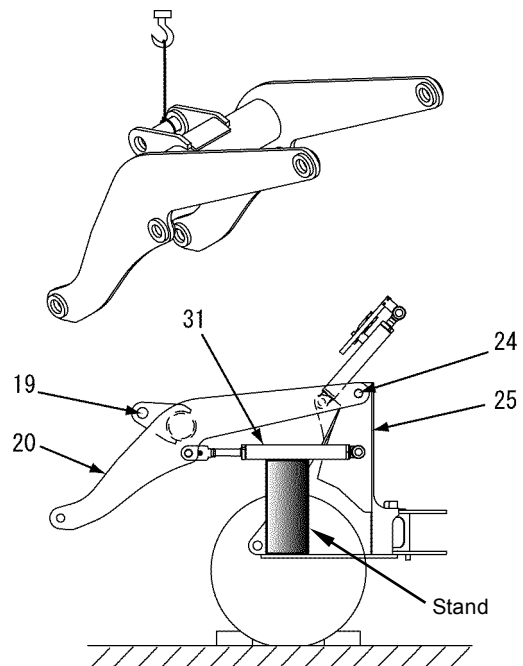

W4FG-04-01-006

## ATTACHMENT / Cylinder

---

### Removal of Bucket Cylinder



**CAUTION: Bucket cylinder (1) weight:**  
ZW80 : 30 kg (66 lb)  
ZW90 : 31 kg (68 lb)

1. Attach a nylon sling onto bucket cylinder (1). Hold bucket cylinder (1).
2. Disconnect hoses (2, 3) from bucket cylinder (1). Cap the open ends.

 : 19 mm, 22 mm

3. Remove bolt (7), spring washer (8) and washer (9) from pin (6).

 : 19 mm



**CAUTION: Metal fragments may fly off when a hammer is used. Wear necessary protection, such as goggles, hard hats, etc in order to prevent personal injury.**

4. Remove pin (6) from bell crank (4).
5. Remove bolt (10), spring washer (11) and washer (12) from pin (13).

 : 19 mm



**CAUTION: Metal fragments may fly off when a hammer is used. Wear necessary protection, such as goggles, hard hats, etc in order to prevent personal injury.**

6. Remove pin (13) from front frame (14).
7. Remove bucket cylinder (1) shims (5) (2 used) on the bucket cylinder rod side, and shims (2 used) on bucket cylinder bottom side from bell crank (4) and front frame (14).

### Installation of Bucket Cylinder



**CAUTION: Bucket cylinder (1) weight:**  
ZW80 : 30 kg (66 lb)  
ZW90 : 31 kg (68 lb)

1. Attach a nylon sling onto bucket cylinder (1). Hold bucket cylinder (1).
2. Fit the pin (13) holes on bucket cylinder (1) bottom side and the front frame (14).



**CAUTION: Metal fragments may fly off when a hammer is used. Wear necessary protection, such as goggles, hard hats, etc in order to prevent personal injury.**

3. Install pin (13) to front frame (14) with washer (12), spring washer (11) and bolt (10).

 : 19 mm

4. Connect hoses (2, 3) to bucket cylinder (9).

 : 19 mm, 22 mm

5. Start the engine. Extend the piston rod of bucket cylinder (1). Fit the pin (6) holes on bucket cylinder (1) and bell crank (4). Install shims (5) (2 used) to bucket cylinder (1) rod side.



**CAUTION: Metal fragments may fly off when a hammer is used. Wear necessary protection, such as goggles, hard hats, etc in order to prevent personal injury.**

6. Install pin (6) to bell crank (4) with washer (9), spring washer (8) and bolt (7).

 : 19 mm



**CAUTION: Bleed air from the cylinder after completing the work. (Refer to BLEED AIR FROM HYDRAULIC CIRCUIT on W1-1-3.)**

## ATTACHMENT / Cylinder

### Disassembly of Bucket Cylinder

- The disassembling procedure starts on the premise that the hydraulic piping and the bands securing the piping have been removed.



#### CAUTION: Bucket cylinder weight:

ZW80: 30 kg (66 lb)

ZW90: 31 kg (68 lb)

- Secure the cylinder on a workbench horizontally. Drain hydraulic oil from the cylinder.

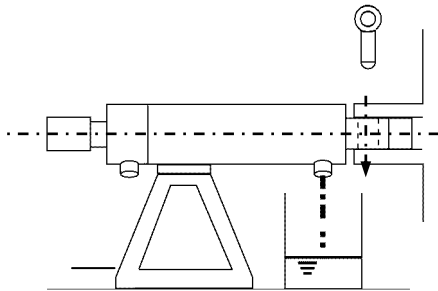

W4EK-03-09-004

**IMPORTANT:** The lock washer forms an integral part with cylinder tube (1). Do not damage cylinder tube (1) and cylinder head (13) when extending the lock washer.

- Pull out piston rod (15) about 50 mm from cylinder tube (1). Install a protective cover to piston rod (15). Extend the lock washer in cylinder tube (1) by using a chisel and a hammer.

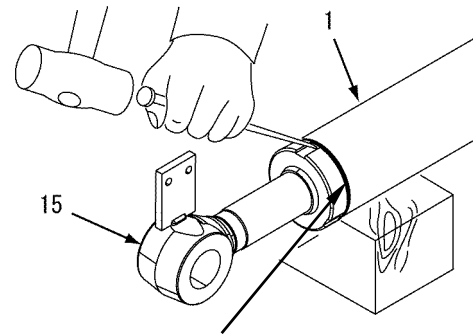

Lock Washer

W4FG-04-02-006

- Loosen cylinder head (13) by using a hook wrench. Remove the piston rod (15) from cylinder tube (1).

Cylinder head (13) diameter

ZW80: 97 mm

ZW90: 105 mm

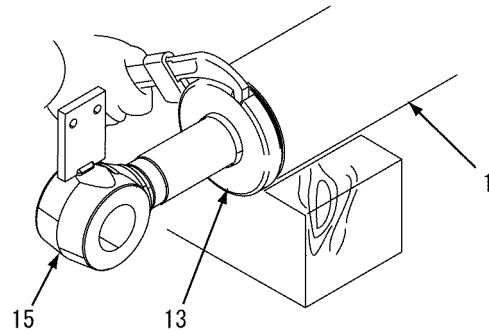

W4FG-04-02-007

**IMPORTANT:** Loosen set screw (4) after cutting the crimped part (2 places) by using a hand drill. Do not lose steel ball (5).

- Secure piston rod (15) horizontally. Remove set screw (4) from piston (6). Remove steel ball (5) from the set screw (4) mounting hole.

 : 6 mm

CLICK HERE TO **DOWNLOAD** THE COMPLETE MANUAL

- Thank you very much for reading the preview of the manual.
- You can download the complete manual from: [www.heydownloads.com](http://www.heydownloads.com) by clicking the link below



- Please note: If there is no response to CLICKING the link, please download this PDF first and then click on it.

CLICK HERE TO **DOWNLOAD** THE COMPLETE MANUAL