

PART NO. WDFX50-EN-00

**HITACHI**

Reliable solutions

# Workshop Manual

# ZH

# 210-6

# 210LC-6

# Hybrid Excavator

ZH210-6 • 210LC-6 HYBRID EXCAVATOR WORKSHOP MANUAL

 **Hitachi Construction Machinery Co., Ltd.**

URL:<http://www.hitachi-c-m.com>

PRINTED IN JAPAN (K) 2018, 03

WDFX50-EN-00

Service Manual consists of the following separate Part No.  
Technical Manual (Operational Principle) : Vol. No.TODFX50-EN  
Technical Manual (Troubleshooting) : Vol. No.TTDFX50-EN  
Workshop Manual : Vol. No.WDFX50-EN  
Engine Manual : Vol. No.EDFX50-EN

CLICK HERE TO **DOWNLOAD** THE COMPLETE MANUAL

- Thank you very much for reading the preview of the manual.
- You can download the complete manual from: [www.heydownloads.com](http://www.heydownloads.com) by clicking the link below



- Please note: If there is no response to CLICKING the link, please download this PDF first and then click on it.

CLICK HERE TO **DOWNLOAD** THE COMPLETE MANUAL

---

---

## SECTION 5

# FRONT ATTACHMENT

### CONTENTS

#### Group 1 Front Attachment

Removal and Installation of Front Attachment...W5-1-1-1

#### Group 2 Cylinder

Removal and Installation of Boom Cylinder.....W5-2-1-1

Removal and Installation of Arm Cylinder .....W5-2-2-1

Removal and Installation of Bucket Cylinder .....W5-2-3-1

Disassembly of Boom, Arm, and Bucket

    Cylinders.....W5-2-5-1

Assembly of Boom, Arm, and Bucket

    Cylinders.....W5-2-5-7

## SAFETY

---

- Do not remove or disassemble hybrid system equipment. This machine incorporates parts at high voltage; the lithium-ion battery unit in particular is always at high voltage. Accidentally touching it may cause electrical shock, which may result in serious injury or death.
- If hybrid equipment or the power harness are damaged from an accident such as a collision, serious bodily injury or death may result from electrical shock or burns, so be careful not to touch them accidentally and contact your authorized dealer.
- There is a possibility that installed equipment may be damaged if the machine is involved in a collision while driving, if this is the case turn the key to the OFF position and stop the engine.
- If a fire breaks out, use fire extinguishers to put it out.
- Do not disconnect the connectors of the power harness (orange). Handling the harness or connectors improperly may cause electrical shock, which may result in serious injury or death.
- Lithium-ion batteries are used in the storage equipment of the hybrid system. Follow the various precautions when handling the lithium-ion batteries. The on-board lithium-ion battery unit, which maintains a constant high voltage, presents a potential risk of death or serious personal injury from fire, explosion, electrical shock, etc. In addition, the lithium-ion battery contains an organic electrolytic solution. In case of an abnormality, the electrolytic solution may be emitted as a combustible hot gas, which may cause burns, blindness, skin disorders, etc.
- The safety messages in this SAFETY chapter are intended to illustrate basic safety procedures of machines. However it is impossible for these safety messages to cover every hazardous situation you may encounter. If you have any questions, you should first consult your supervisor and/or your authorized dealer before operating or performing maintenance work on the machine.

---

### Prepare for Emergencies

- Be prepared for a fire or an accident.
  - Keep a first aid kit and fire extinguisher on hand.
  - Thoroughly read and understand the label attached on the fire extinguisher to use it properly.
  - To ensure that a fire extinguisher can be always used when necessary, check and service the fire extinguisher at the recommended intervals as specified in the fire extinguisher manual.
  - Establish emergency procedure guidelines to cope with fires and accidents.
  - Keep emergency numbers for doctors, ambulance service, hospital, and fire department posted near your telephone.



SA-437

## SAFETY

---

### Provide Signals for Jobs Involving Multiple Machines

- For jobs involving multiple machines, provide signals commonly known by all personnel involved. Also, appoint a signal person to coordinate the job site. Make sure that all personnel obey the signal person's directions.



SA-481

---

### Confirm Direction of Machine to Be Driven

- Incorrect travel pedal/lever operation may result in serious injury or death.
  - Before driving the machine, confirm the position of the undercarriage in relation to the operator's position. If the travel motors are located in front of the cab, the machine will move in reverse when travel pedals/levers are operated facing forwards.

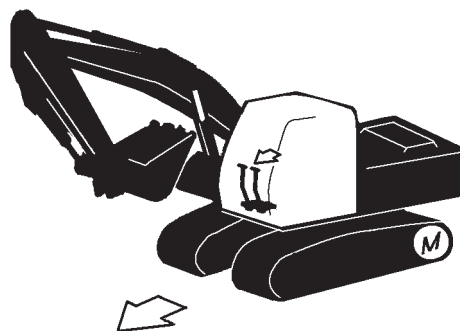

SA-491

## SAFETY

---

### Park Machine Safely

To avoid accidents:

- Park machine on a firm, level surface.
- Lower the bucket and blade to the ground.
- Run engine at slow idle speed without loads.
- Turn key switch to OFF to stop engine.
- Remove the key from the key switch.
- Pull the pilot control shut-off lever to the LOCK position.
- Close windows, roof vent, and cab door.
- Lock all access doors and compartments.



SA-2590

---

### Handle Fluids Safely—Avoid Fires

- Handle fuel with care; it is highly flammable. If fuel ignites, an explosion and/or a fire may occur, possibly resulting in serious injury or death.
  - Do not refuel the machine while smoking or when near open flame or sparks.
  - Always stop the engine before refueling the machine.
  - Fill the fuel tank outdoors.
- All fuels, most lubricants, and some coolants are flammable.
  - Store flammable fluids well away from fire hazards.
  - Do not incinerate or puncture pressurized containers.
  - Do not store oily rags; they can ignite and burn spontaneously.
  - Securely tighten the fuel and oil filler caps.



SA-018



SA-019

## SAFETY

---

### Precautions for Welding and Grinding

- Welding may generate gas and/or small fires.
  - Be sure to perform welding in a well ventilated and prepared area. Store flammable materials in a safe place before starting welding.
  - Only qualified personnel should perform welding. Never allow an unqualified person to perform welding.
  - Turn the battery disconnect switch to the OFF position before performing welding on the machine.
- Grinding on the machine may create fire hazards. Store flammable materials in a safe place before starting grinding.
- After finishing welding and grinding, recheck that there are no abnormalities such as the area surrounding the welded area still smoldering.
- Before doing any welding, please consult your nearest authorized dealer.



SA-818

## SAFETY SIGNS

All safety signs and their locations affixed on the machine are illustrated in this group. Make sure of the contents described in the safety signs through reading actual ones affixed on the machine to ensure safe machine operation. Always keep the safety signs clean. In case a safety sign is broken or lost, immediately, obtain a new replacement and affix it again in position on the machine. Use the part No. indicated under the right corner of each safety sign illustration when placing an order of it to the Hitachi dealer.

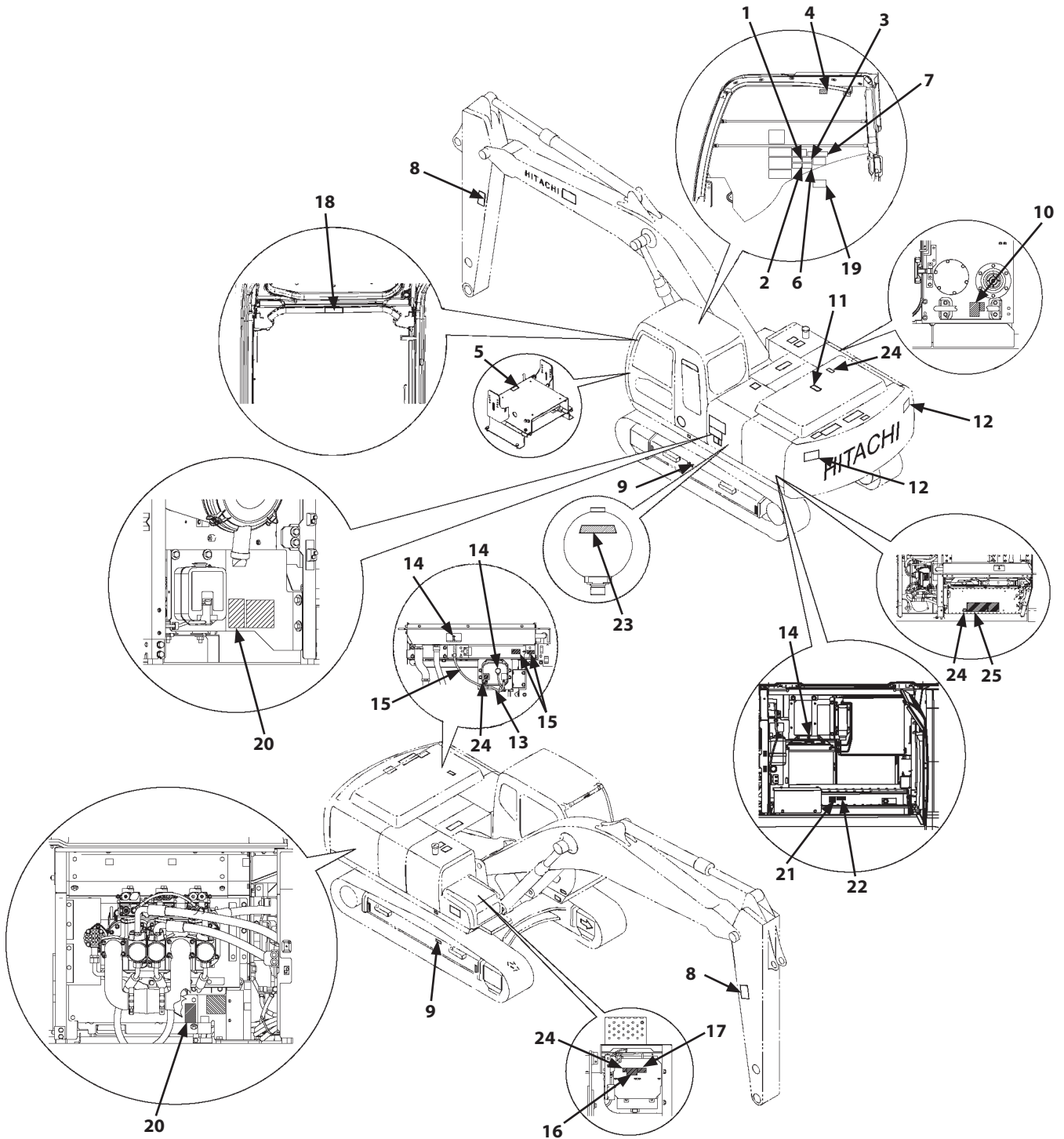

SS-3949

# SECTION AND GROUP CONTENTS

## WORKSHOP MANUAL

---

### SECTION 1 GENERAL

Group 1 Precautions for Disassembling and Assembling
Group 2 Tightening
Group 3 Painting
Group 4 Bleeding Air
Group 5 Preparation
Group 6 Precautions for Hybrid System

### SECTION 2 MAINTENANCE STANDARD

Group 1 Upperstructure
Group 2 Undercarriage
Group 3 Front Attachment

### SECTION 3 UPPERSTRUCTURE

Group 1 Cab
Group 2 Counterweight
Group 3 Main Frame
Group 4 Engine
Group 8 Pump Device
Group 9 Control Valve
Group 10 Swing Device
Group 11 Pilot Valve
Group 12 Solenoid Valve
Group 13 Signal Control Valve
Group 14 Muffler Filter

### SECTION 4 UNDERCARRIAGE

Group 1 Swing Bearing
Group 2 Travel Device
Group 3 Center Joint
Group 4 Track Adjuster
Group 6 Upper and Lower Rollers
Group 7 Track

### SECTION 5 FRONT ATTACHMENT

Group 1 Front Attachment
Group 2 Cylinder

### SECTION 6 HYBRID

Group 1 PCU
Group 2 Lithium Ion Battery Unit
Group 3 Solenoid Valve
Group 4 Relief Valve

All information, illustrations and specifications in this manual are based on the latest product information available at the time of publication. The right is reserved to make changes at any time without notice.

# SECTION 1 GENERAL

## Group 2 Tightening

### Tightening Bolts and Nuts

**CAUTION:** Use tools appropriate for the work to be done. Makeshift tools and procedures can create safety hazards. For loosening and tightening nuts and bolts, use correct size tools. Otherwise, tightening tools may slip, potentially causing personal injury.



WDAA-01-02-001







#### Bolt Types

Tighten the nuts or bolts correctly to the torque specifications.

As the different types and grades of bolt are used, use and tighten the correct bolts correctly when assembling the machine or components.

#### Specified Tightening Torque Chart

2013/09

Bolt Dia. mm	Hexagon Head Bolt						Socket Bolt			
	   WDAA-01-02-002		   WDAA-01-02-003		 WDAA-01-02-004		Wrench Size mm	Socket Bolt		Wrench Size mm
	N·m	(lbf·ft)	N·m	(lbf·ft)	N·m	(lbf·ft)		N·m	(lbf·ft)	
6					3 to 4	(2.2 to 3)	10			5
8	30	(22)	20	(15)	10	(7.4)	13	20	(15)	6
10	65	(48)	50	(37)	20	(15)	17	50	(37)	8
12	110	(81)	90	(66)	35	(26)	19	90	(66)	10
14	180	(133)	140	(103)	55	(41)	22	140	(103)	12
16	270	(200)	210	(155)	80	(59)	24	210	(155)	14
18	400	(300)	300	(220)	120	(89)	27	300	(220)	14
20	550	(410)	400	(300)	170	(125)	30	400	(300)	17
22	750	(550)	550	(410)	220	(162)	32			
24	950	(700)	700	(520)	280	(205)	36			
27	1400	(1030)	1050	(770)	400	(300)	41			
30	1950	(1440)	1450	(1070)	550	(410)	46			
33	2600	(1920)	1950	(1440)	750	(550)	50			
36	3200	(2360)	2450	(1810)	950	(700)	55			

## SECTION 1 INTRODUCTION

### Group 3 Painting

#### Painting

##### Painting specifications

Surfaces to Be Painted	Painting Color
Main surface of upperstructure (except cab)	YR1-01 [TAXI yellow]
Main frame	P1-01 [High Grade Black]
Inner	N-40 [N4 Gray]
Engine cover	P1-01 [High Grade Black]
Handrail	P1-01 [High Grade Black]
Front Attachment (without the bucket)	YR1-01 [TAXI yellow]
Bucket (including the pin edges)	N-10 [Black]
Track (including swing bearing)	N-10 [Black]
Floor plate	N-40 [N4 Gray]

##### Final painted color

Inside and outside surface of cab	P1-01 [High Grade Black] Y1-03 [Shining Silver]
Right window beam	Charcoal Black
Seat stand	Black (N2.0)
Lever (Travel, pilot shut-off)	Warm Gray (N2.5)
Rear Camera	P1-01 [High Grade Black]
Exhaust pipe	Black Heat-Resistant Coating
Toolbox, toolbox cover	P1-01 [High Grade Black]
Decoration cover, Step	P1-01 [High Grade Black]
Handrail on upperstructure right side	P1-01 [High Grade Black]
Mirror stay	P1-01 [High Grade Black]
Nonslip plate	Kansai Paint AMIRAC 1400 [Deep Black]
Center cover mounting support	P1-01 [High Grade Black]
Handrail (above the cab)	P1-01 [High Grade Black]

# SECTION 1 INTRODUCTION

## Group 5 Preparation

### Pressure Release from Expansion Tank

**CAUTION:** Do not loosen cap when the coolant temperature of radiator is too high. Hot steam may spout out and cause severe burns. Wait until coolant cools and loosen cap slowly. Release all pressure and remove the cap.

1. Park the machine on a solid and level surface. Set the front attachment in position for checking hydraulic oil level.
2. After stopping the engine, remove cap (1) of expansion tank (2).

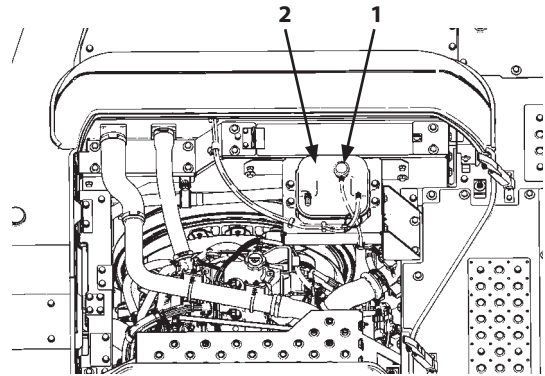

MDFX-07-024

### Inspection after work

Check that the coolant level in expansion tank (2) is between FULL (3) and LOW (4).

Remove cap (1) of expansion tank (2) to supply coolant if the coolant is insufficient.

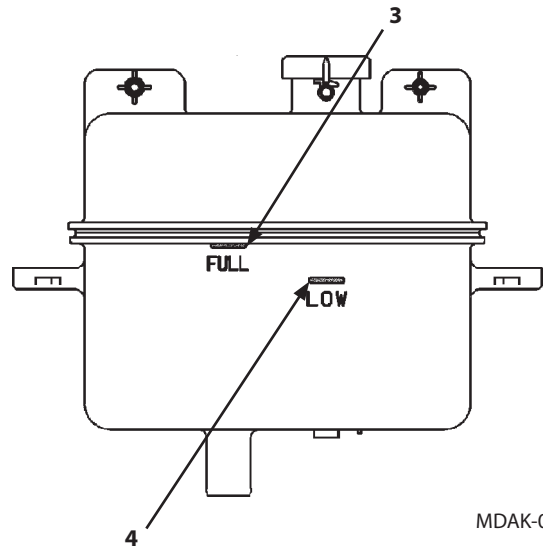

MDAK-07-047

# SECTION 1 INTRODUCTION

## Group 6 Precautions for the Hybrid System

---

### 4. Precautions in the event of submersion in water

The hybrid components does not support submersion in water. If the engine unavoidably needs to be started, remove the hybrid fuses (#36, #38, #39, #40) so that the hybrid system cannot start.

If the hybrid components (lithium-ion battery unit, PCU-A, PCU-S, swing electric motor, assist alternator motor, power wire harness) are submerged in water, they need to be replaced.

### 5. Precautions for Disposal

When disposing of the lithium-ion battery unit, follow the process specified by Hitachi Construction Machinery for safe disposal. The lithium ion battery unit always holds a high voltage and, if it is disposed of in a wrong way, it may lead to an accident resulting in serious personal injury, such as fire, explosion, and electric shock. In addition, an organic electrolytic solution is sealed in the lithium ion battery. Under abnormal conditions, the electrolytic solution may be released as combustible hot gas, resulting in serious injury, such as burns and blindness.

### 6. About Electrolytic Solution in Lithium-ion Battery

The electrolytic solution in the lithium-ion battery is classified as a hazardous chemical substance. For safety of the lithium-ion battery and electrolytic solution, refer to the safety data sheet (SDS).

## SECTION 1 INTRODUCTION

### Group 6 Precautions for the Hybrid System

#### Connection of Power Connector

**CAUTION:** During the disconnection, connection, and covering of the power connector, there is the risk of electric shock. Wear insulated gloves.

1. With handle (2) raised 90°, insert power connector (4).
2. While pressing power connector (4), tilt handle (2) to connect power connector (4).
3. Press in lock part (3) to lock handle (2).
4. Install the lithium-ion battery disconnect switch. (Refer to Removal and Installation of Lithium-ion Battery Disconnect Switch.)

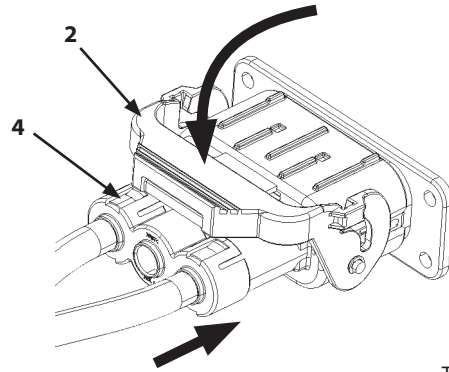

TDFX-05-01-011

#### Precautions for handling

During the disconnection and connection of the power connector, follow the predetermined procedures. After disconnecting the power connector, cover it with plastic bags or tape with care not to touch its terminals to prevent water or dust from entering the connector. If water or dust accidentally enters the connector, remove it with clean air without contamination and let it dry naturally. To avoid the risk of electric shock, do not touch the inside of the connectors nor insert a tool. Connectors have resin parts. Therefore, handle them with care not to damage in such a way as to hit against something. In addition, when connecting it again, take care not to cause water or dust to enter the connector. Before connecting the connectors, check that there are no bends and rust of terminals. After connecting the connector, be sure to lock it. Check the clamp of the wire harness for looseness.

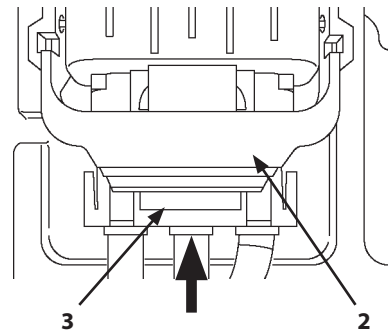

TDFX-05-01-026

## SECTION 2 MAINTENANCE STANDARD

### Group 1 Upperstructure

---

#### Swing Hydraulic Motor

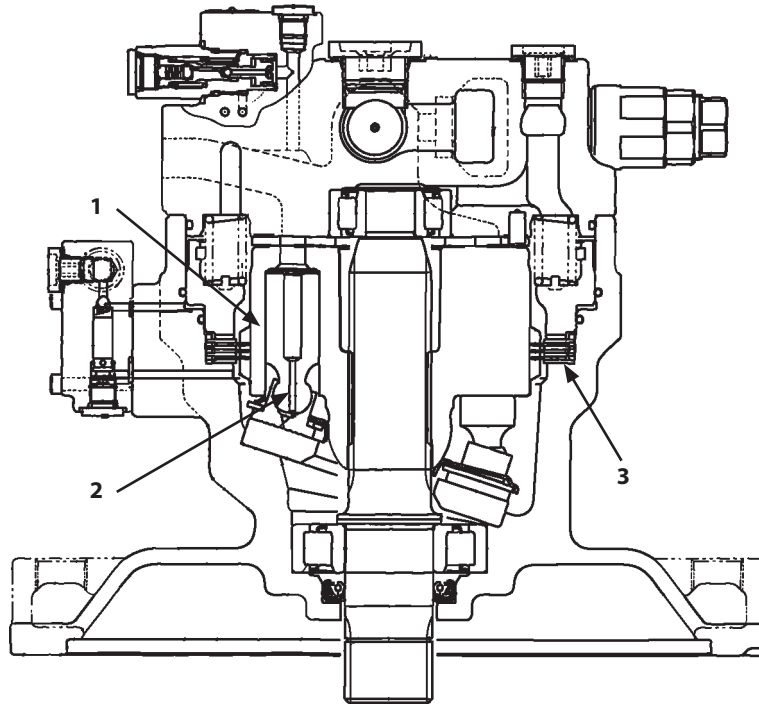

TDAB-03-02-001

1- Rotor

2- Plunger (9 Used)

3- Friction Plate (3 Used)

## SECTION 2 MAINTENANCE STANDARD

### Group 2 Undercarriage

#### Upper Roller

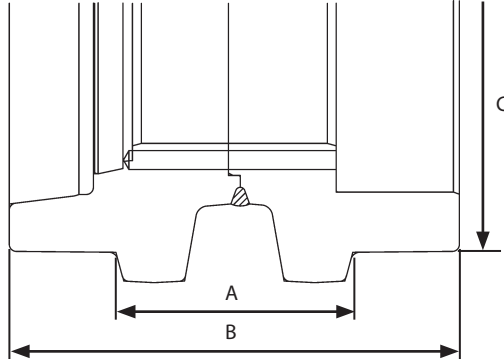

WDDE-02-02-001

Unit: mm (in)

	Standard	Allowable Limit	Remedy
A	84 (3.3)	-	Replace
B	165 (6.5)	-	
C	120 (4.7)	[110 (4.3)]	

 NOTE: Values in [ ] are just for reference.

# SECTION 2 MAINTENANCE STANDARDS

## Group 3 Front Attachment

### Standard Dimensions for Arm and Bucket Connection

**IMPORTANT:** If the front attachment of a previous model machine is used, use the grease intervals for previous model machine.

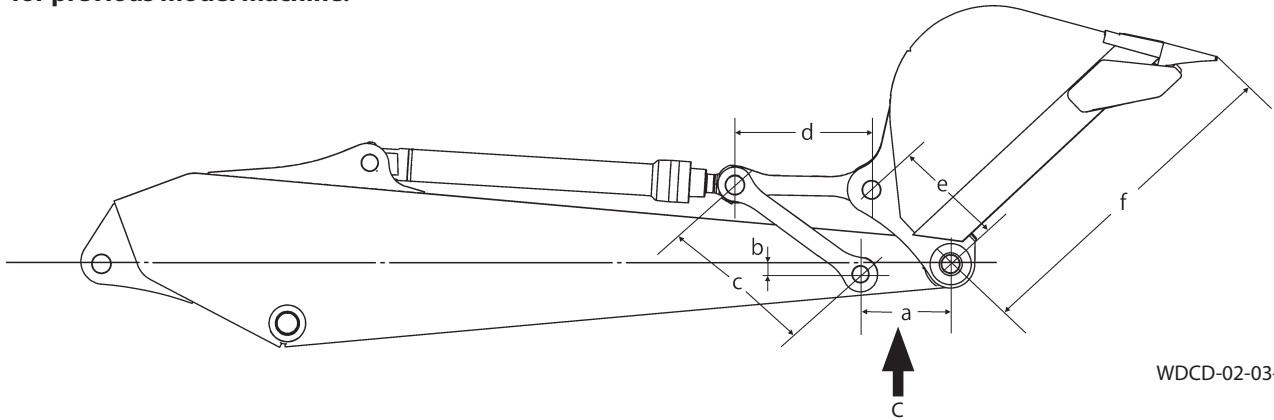

WDCD-02-03-005

View C

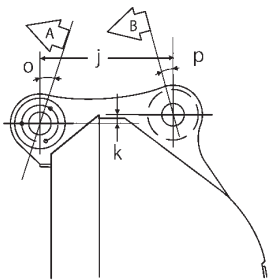

Section A

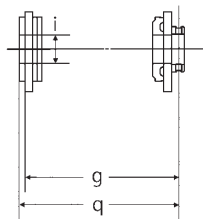

Section B

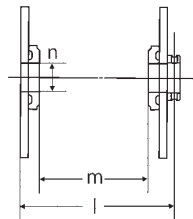

WDC4-02-03-001

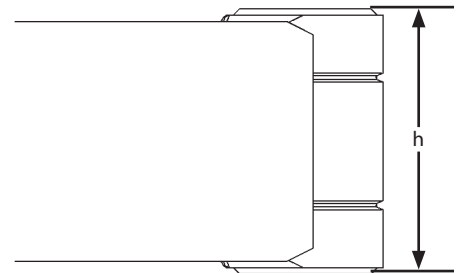

WDBR-02-03-001

Unit: mm

	ZH200-6 Class	ZH200-5B, A Class	ZX200-5 Class	ZX200-3 Class
a	450	←	←	←
b	0	←	10	0
c	604	←	←	←
d	580	←	←	←
e	476	←	←	←
f	1471	←	←	←
g	433	←	←	←
h	305	←	←	←
i	80	←	←	←
j	475	←	←	←
k	31	←	←	←
l	433	←	←	←
m	307	←	←	←
n	80	←	←	←
o	15°	←	←	←
p	15°	←	←	←
q	449	←	←	←

## SECTION 3 UPPER STRUCTURE

### Group 1 Cab

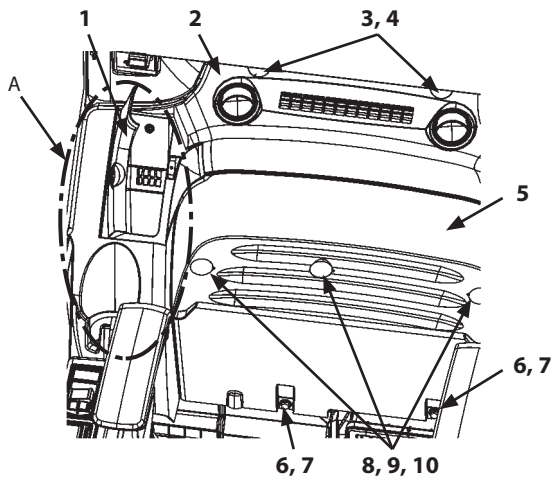

WDAA-03-01-052

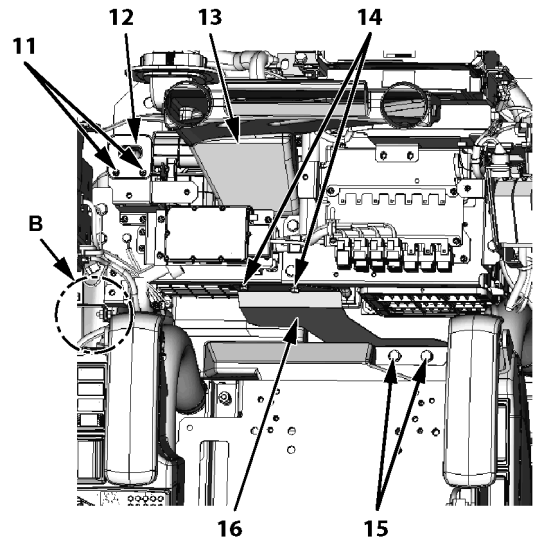

WDFX-03-01-001

Detail A

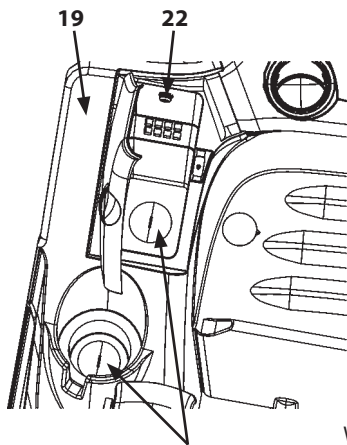

20, 21, 22

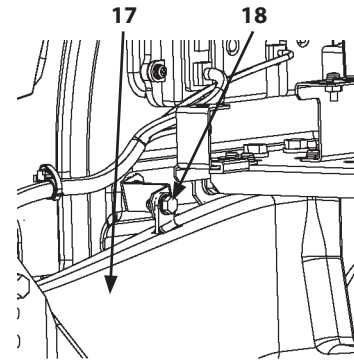

WDAA-03-01-062

Detail B



WDAA-03-01-065

11. Open cover (1).
12. Turn caps (20) (2 used) counterclockwise. Remove caps (20) (2 used). Remove seals (21) (2 used) and screws (22) (3 used). Remove cover (19).
13. bolts (6) (2 used) and washers (7) (2 used).  
 : 13 mm
14. Remove caps (8) (3 used). Remove rubbers (9) (3 used) and screws (10) (3 used). Remove cover (5).

15. Remove caps (3) (2 used). Remove screws (4) (2 used). Remove cover (2) and duct (13).
16. Remove bolts, washers (15) (2 used).  
 : 17 mm
17. Remove bolts, washers (14) (2 used). Remove cover (16).  
 : 13 mm
18. Remove screws (11) (2 used). Remove duct (12).
19. Remove bolt, washer (18). Remove duct (17).  
 : 13 mm

## SECTION 3 UPPER STRUCTURE

### Group 1 Cab

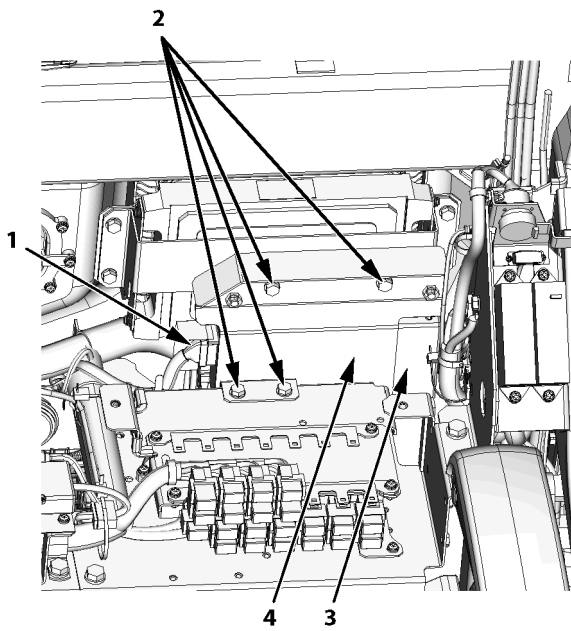

WDFX-03-01-007

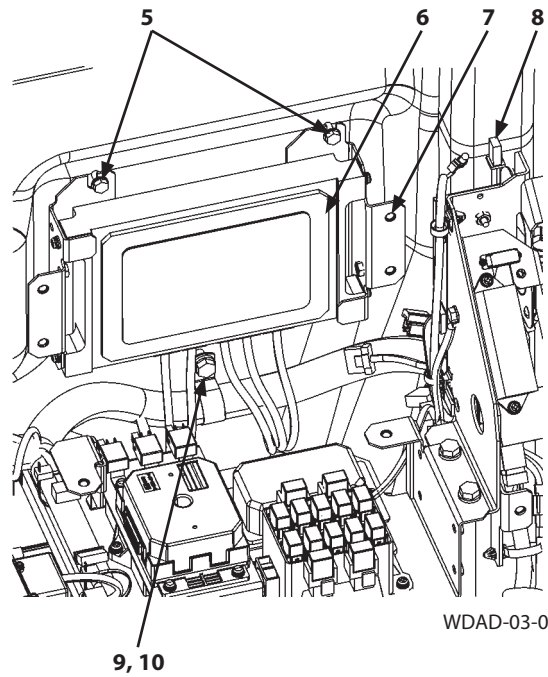

WDAD-03-01-008

60. Disconnect connector (1).
61. Remove bolts, washers (2) (4 used) Remove DC/DC converter (3) and bracket (4).

 : 13 mm

62. Remove bolts, washers (5) (4 used). Remove MC (6) and bracket (7).

 : 13 mm

63. Disconnect connector (8).
64. Remove bolt, washer (9) and clip (10).

 : 17 mm

## SECTION 3 UPPER STRUCTURE

### Group 1 Cab

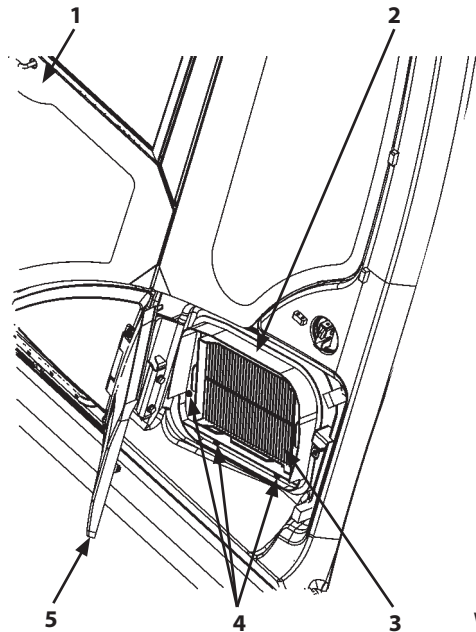
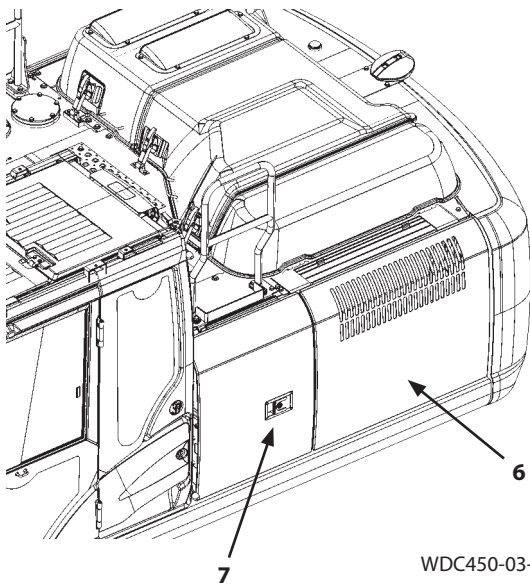

30. Close covers (6, 7).

31. Install filter case (2) with screws (4) (6 used).

 : 3 N·m

32. Install filter (3).

33. Close cover (5).

34. Open door (1).

# SECTION 3 UPPERSTRUCTURE

## Group 1 Cab

Unit: mm

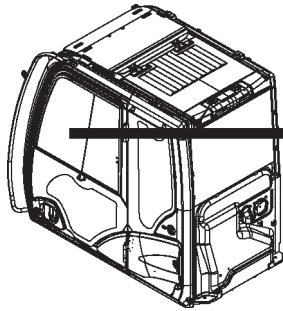

WDAA-03-01-031

Section A



WDAA-03-01-004

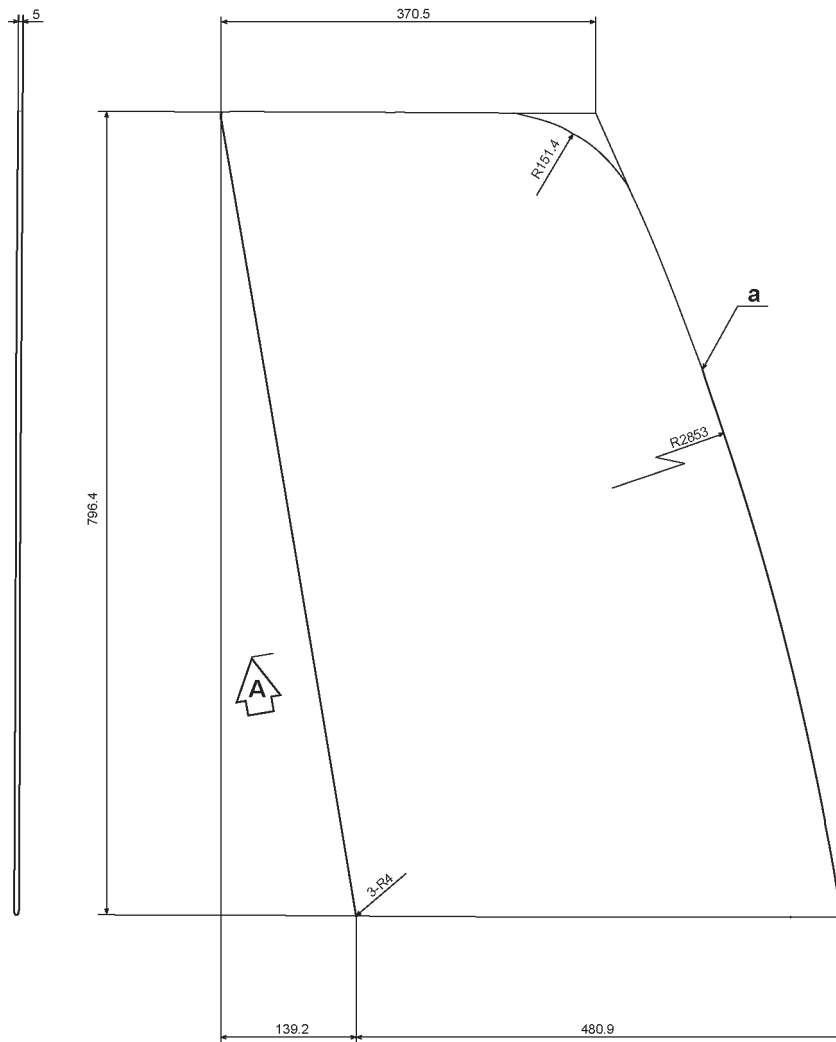

a - Chamfer along the Periphery

WDAA-03-01-003

# SECTION 3 UPPERSTRUCTURE

## Group 1 Cab

Unit: mm

Rear Glass

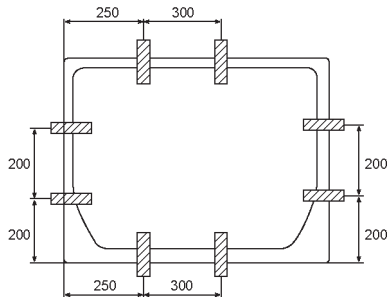

WDAA-03-01-039

Right-Hand Glass

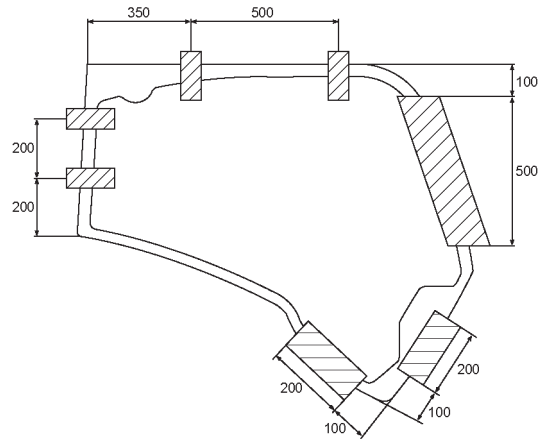

WDAA-03-01-040

Rear Left-Hand Glass

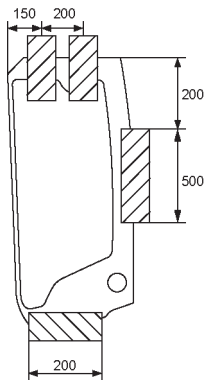

WDAA-03-01-041

Lower Door Glass

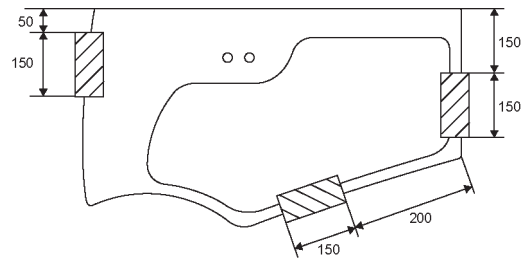

WDAA-03-01-042

Spacer A

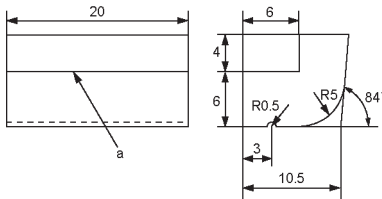

WDAA-03-01-043

Spacer B

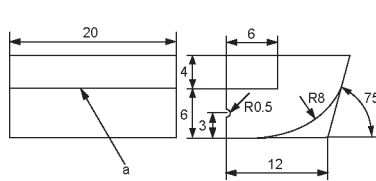

WDAA-03-01-044

Spacer C

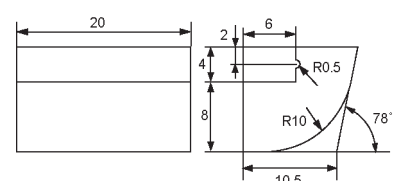

WDAA-03-01-045

a - Two-Side Adhesive Tape

a - Two-Side Adhesive Tape

Dam Rubber

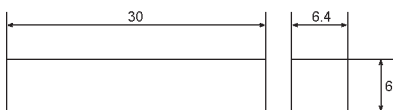

WDAA-03-01-046

## SECTION 3 UPPERSTRUCTURE

### Group 2 Counterweights

---

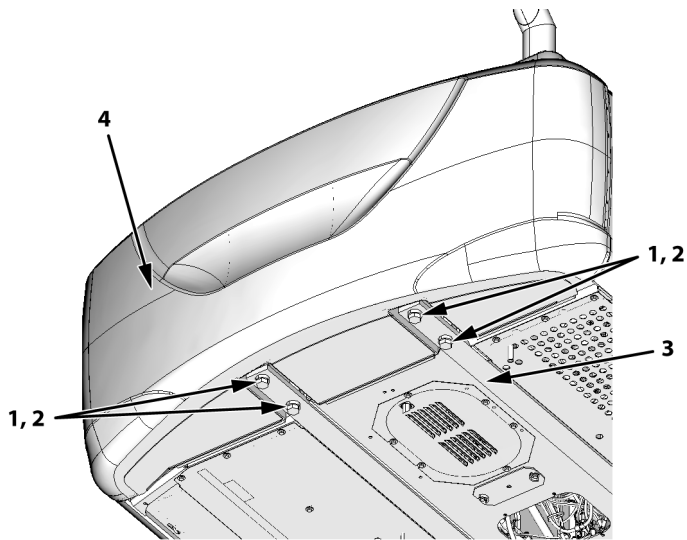

WDC4-03-02-003

10. Remove bolts (1) (4 used) and washers (2) (4 used).  
Remove counterweight (4) from main frame (3).

 : 46 mm

# SECTION 3 UPPERSTRUCTURE

## Group 3 Main Frame

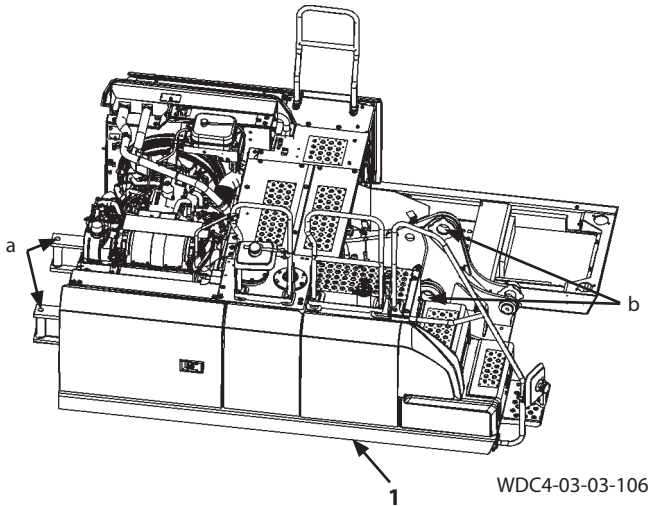

a- Counterweight Mounting Part      b- Boom Mounting Bracket Hole

WDC4-03-03-106

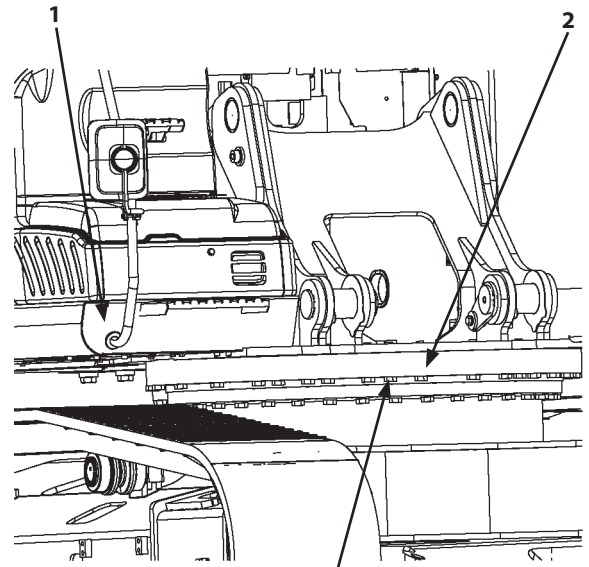

3  
↑  
A

WDAB-03-03-003

**⚠ CAUTION: Main frame (1) weight: 5290 kg**

3. Attach the wire ropes onto the counterweight mounting parts (a) (2 places) of main frame (1) and two boom mounting bracket holes (b).
4. Adjust the center of the gravity of main frame (1) by the using the chain block.
5. Fit the matching marks on outer race (2) of the swing bearing, main frame (1), and the knock pin.
6. Apply THREEBOND #1102 or the equivalent to the end of bolts (4) (2 used). Temporarily install main frame (1) onto outer race (2) of the swing bearing with spacers (6) (5 used), bolts (5) (5 used), bolts (3) (30 used), and bolts (4) (2 used).

 : 30 mm

7. Tighten bolts (5) (5 used), bolts (3) (30 used), and bolts (4) (2 used).

 : 30 mm

 : 510 N·m

View A

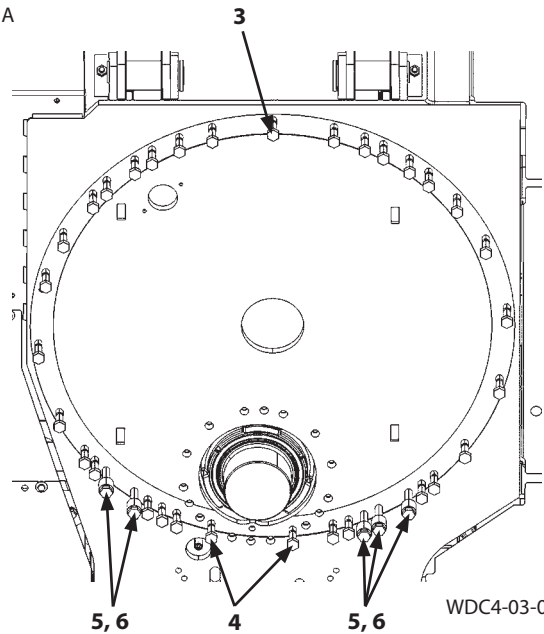

WDC4-03-03-103

## SECTION 3 UPPER STRUCTURE

### Group 4 Engine

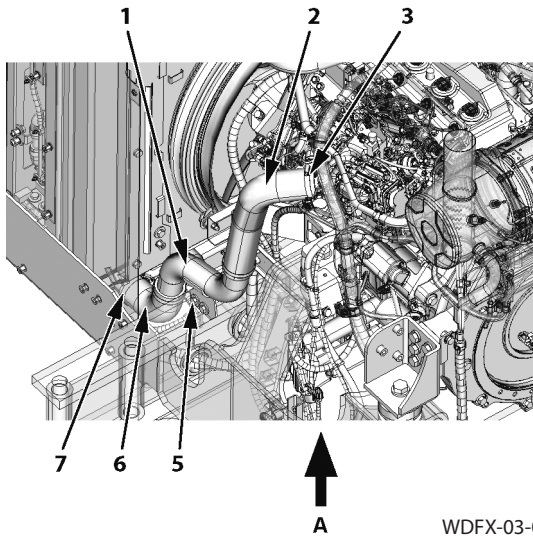

WDFX-03-04-007

View A

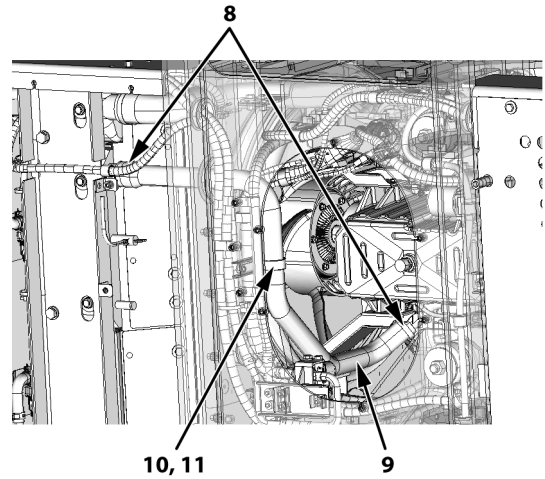

WDFX-03-04-008

36. Remove clamps (8) (2 used). Disconnect the both ends of hose (9).

 : 8 mm

37. Remove bolt, washer (10). Remove clip (11). Remove hose (9).

 : 17 mm

38. Remove clamp (7). Disconnect hose (6) on the inter-cooler side.

 : 7 mm

39. Remove clamp (3). Disconnect hose (2) on the engine side.

 : 7 mm

40. Remove bolts, washers (5) (2 used). Remove the pipe (1) assembly.

 : 17 mm

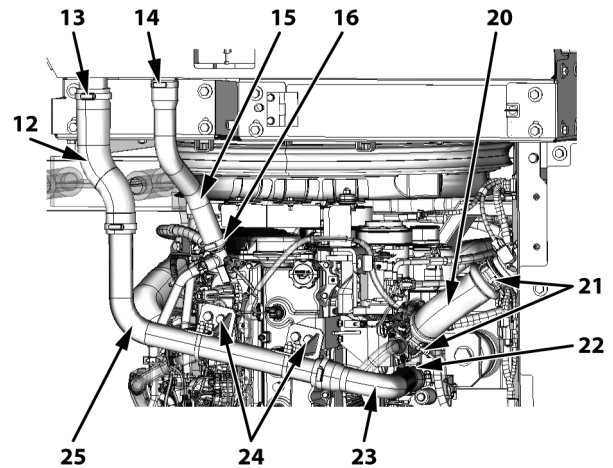

WDFX-03-04-009

41. Remove clamp (22). Disconnect hose (23) on the engine side.

 : 7 mm

42. Remove clamp (13). Disconnect hose (12) on the inter-cooler side.

 : 7 mm

43. Remove bolts, washers (24) (4 used). Remove the pipe (25) assembly.

 : 17 mm

## SECTION 3 UPPER STRUCTURE

### Group 4 Engine

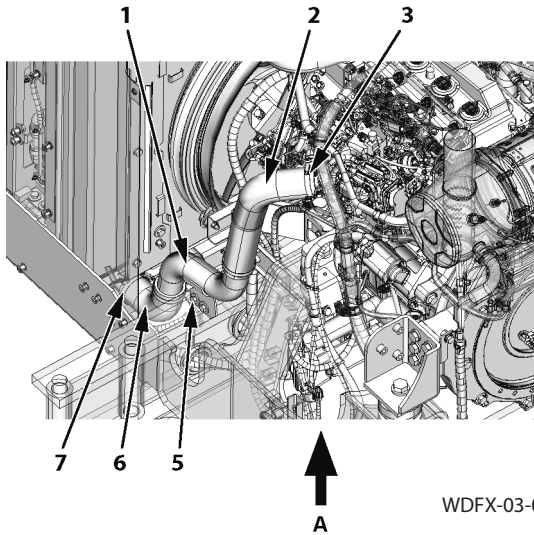

View A

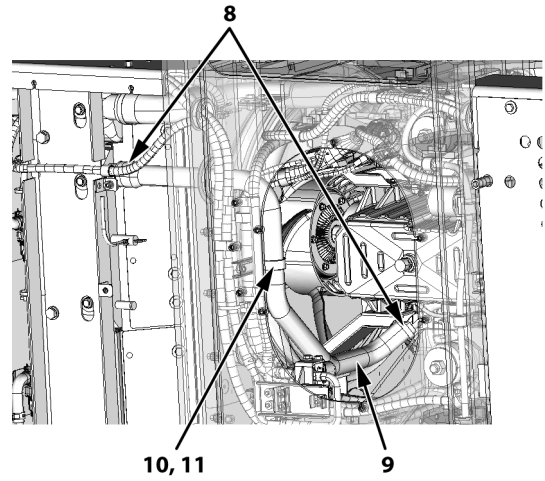

30. Connect hose (2) on the engine side with clamp (3).

 : 7 mm

 : 6 N·m

31. Connect hose (6) on the intercooler side with clamp (7).

 : 7 mm

 : 6 N·m

32. Connect both ends of hose (9) with clamps (8) (2 used).

 : 8 mm

 : 6 N·m

33. Install clip (11) with bolt, washer (10).

 : 17 mm

 : 50 N·m

34. Install the pipe (1) assembly with bolts, washers (5) (2 used).

 : 17 mm

 : 50 N·m

## SECTION 3 UPPERSTRUCTURE

### Group 4 Engine

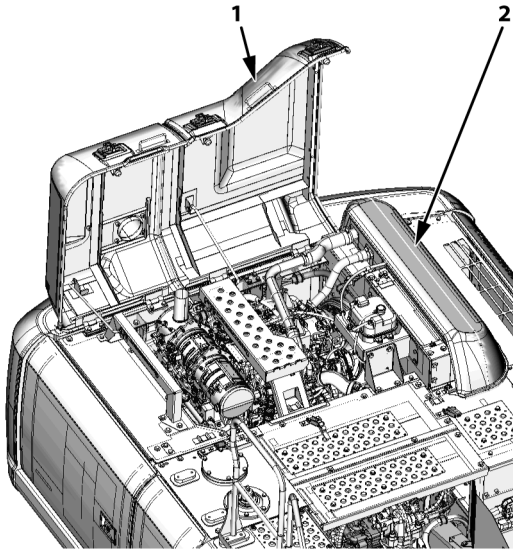

WDFX-03-04-023

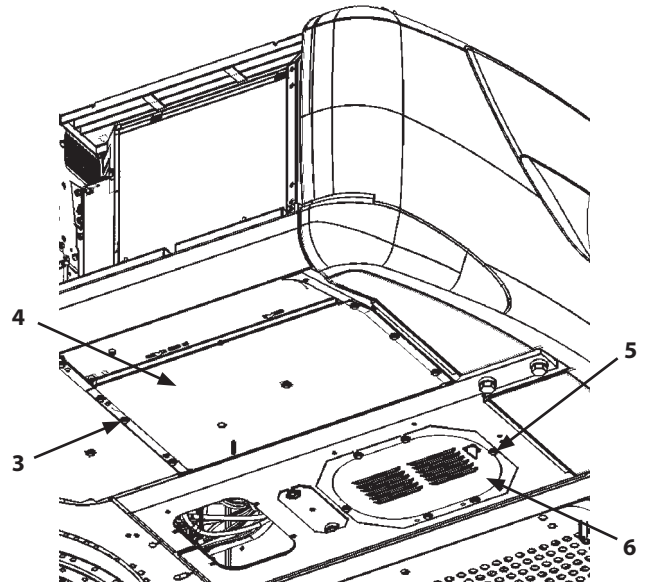

WDC4-03-04-103

13. Close radiator cover (2).
14. Close engine cover (1).

15. Install cover (6) with bolts, washers (5) (6 used).

 : 17 mm

 : 50 N·m

16. Install cover (4) with bolts, washers (3) (5 used).

 : 17 mm

 : 50 N·m

## SECTION 3 UPPERSTRUCTURE

### Group 8 Pump Device

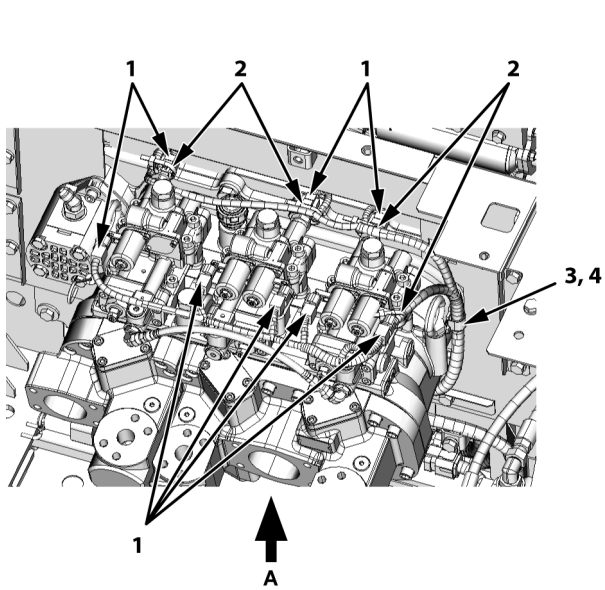

View A

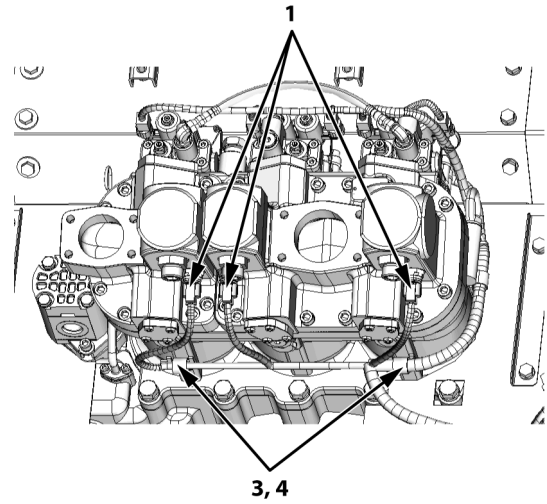



WDFX-03-08-007

WDFX-03-08-006

**IMPORTANT: Replace clip band (2) with the new one.**

13. Connect connectors (1) (11 used). Install clip bands (2) (4 used).
14. Install clips (4) (3 used) with bolts, washers (3) (3 used).

 : 10 mm

 : 3~4 N·m

## SECTION 3 UPPERSTRUCTURE

### Group 8 Pump Device

#### Disassembly of Pump Device

1. Disconnect the both ends of hose (101) from regulators (98, 100).

 : 17 mm

2. Remove sensors (64) (3 used) and O-rings (64A) (3 used) from selector heads (45, 46).

 : 27 mm

3. Remove plug (119) and O-ring (119A) from gear casing (120). Drain off engine oil.

 : 22 mm

 **NOTE:** Amount of oil: 1.9L

 **CAUTION:** Place the pump device with regulator (99) up.

4. Remove socket bolts (95, 97) (2 used for each) from regulator (99). Raise regulator (99) toward the selector head (45) side. Remove regulator (99) from pump casing (01). Do not remove socket bolt (96).

 : 8 mm

5. Remove regulators (98, 100) from pump casing (01) in the same way as step 4.

**IMPORTANT:** Do not drop stopper (42) inside pump casing (01) or other areas when removing stopper (42).

6. Remove O-rings (76) (3 used), O-rings (59) (12 used), O-rings (58) (5 used), spring pins (74) (6 used), and stoppers (42) (6 used) from the regulator mounting surface of pump casing (01).

 **CAUTION:** Pump device weight: 240 kg

 **CAUTION:** When hoisting the pump device, do not take pump casing (01) off the ground but turn to the gear casing (120) side.

7. Install eyebolts (M16, Pitch 2.0 mm) (2 used) to eyebolt mounting holes (a) (2 places) of pump casing (01). Attach nylon slings onto the eyebolts. Hoist the pump device. Place the pump device with gear casing (120) down. Place wooden blocks (over 80 mm square) under gear casing (120).

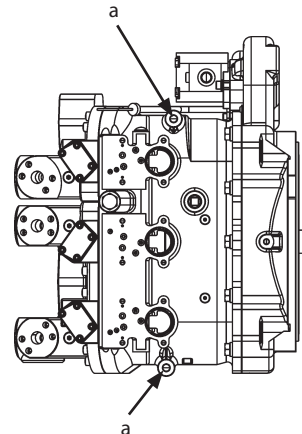

WDCA-03-08-003

a- Eyebolt Mounting Hole

## SECTION 3 UPPERSTRUCTURE

### Group 8 Pump Device

11. Set the preload of bearings (12, 08, 128) (2 used for each) attached to shaft (05) according to the following procedures.

- Tighten bearing nut (14) by using special tool (ST 3010) until it comes in contact with.

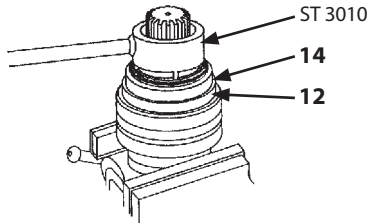

W178-02-11-090

12. Set the preloads of bearings (12, 08, 128) (2 used for each) attached to shafts (06) (2 used) with the same procedure as step 11.

13. Install thrust ring (03) to the side to insert shaft (05) of pump casing (01).

- Install special tool (ST 3178) to bearing (12). Measure the starting torque after rotating 2 to 3 turns.

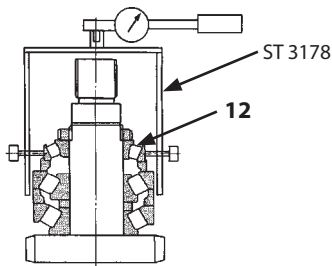

W178-02-11-091

- Adjust bearing nut (14) until the starting torque reaches the specification and adjust bearing nut (14).

 :  $1.5^{+0.9}_0$  N·m

 **NOTE:** Loosen bearing nut (14) if the starting torque exceeds the upper limit of the specified torque. Tap the end of the shaft and release the load of bearing (12).

The tightening rotation speed of bearing nut (14) is  $0.3 \text{ min}^{-1}$ .

## SECTION 3 UPPERSTRUCTURE

### Group 8 Pump Device

#### Assembly of Regulator

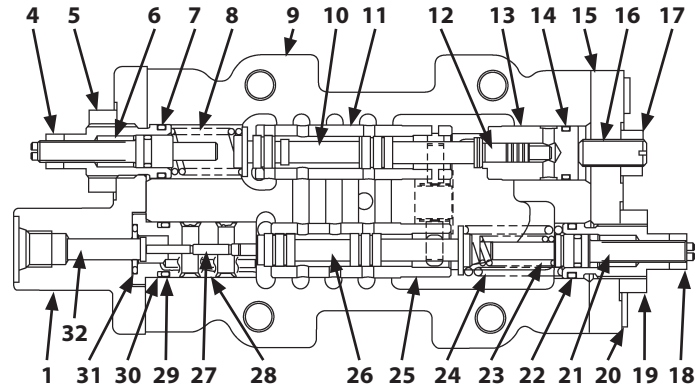

WDCA-03-08-019

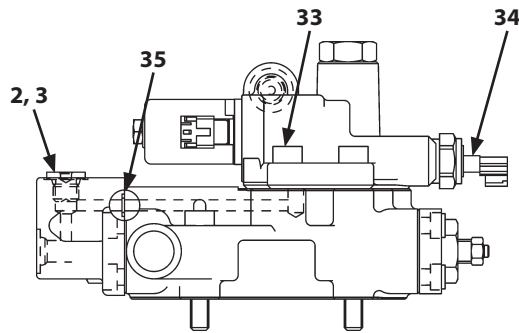

WDDD-03-08-017

- |                     |              |                          |                          |
|---------------------|--------------|--------------------------|--------------------------|
| 1- Cover            | 10- Spool    | 19- Lock Nut             | 28- Cylinder             |
| 2- Plug             | 11- Sleeve   | 20- Socket Bolt (8 Used) | 29- O-Ring               |
| 3- O-Ring           | 12- Piston   | 21- Stopper Assembly     | 30- Backup Ring          |
| 4- Lock Nut         | 13- Cylinder | 22- O-Ring               | 31- O-Ring               |
| 5- Lock Nut         | 14- O-Ring   | 23- Spring               | 32- Piston               |
| 6- Stopper Assembly | 15- Cover    | 24- Spring               | 33- Socket Bolt (2 Used) |
| 7- O-Ring           | 16- Set Bolt | 25- Sleeve               | 34- Solenoid Valve       |
| 8- Spring           | 17- Lock Nut | 26- Spool                | 35- O-Ring               |
| 9- Casing           | 18- Lock Nut | 27- Piston               |                          |

## SECTION 3 UPPERSTRUCTURE

### Group 9 Control Valve

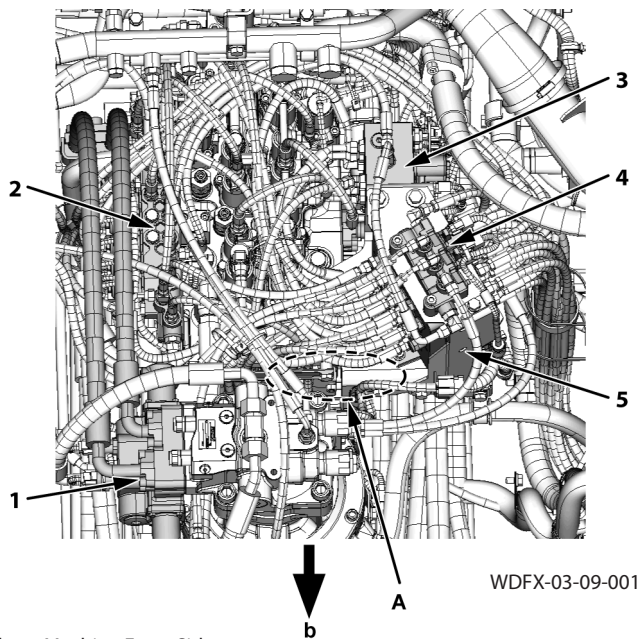



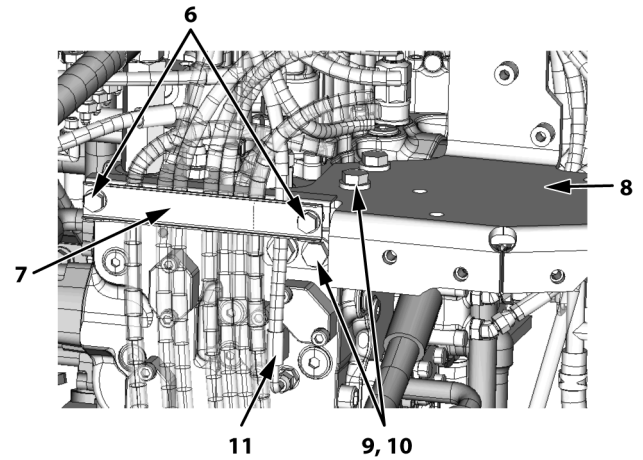

b- Machine Front Side

Detail A



WDFX-03-09-003

9. Remove the swing low-pressure relief valve unit (1). (Refer to W6-4-1.)
  10. Remove the swing control solenoid valve unit (4). (Refer to W6-3-1.)
  11. Remove the 3-spool solenoid valve unit (3). (Refer to W3-12-3.)
  12. Remove signal control valve (5). (Refer to W3-13-1.)
  13. Remove bolts, washers (6) (2 used). Remove clamp (7).  
 : 17 mm
  14. Disconnect hose (11).  
 : 17 mm
  15. Remove bolts (9) (4 used) and washers (10) (4 used). Remove bracket (8).  
 : 22 mm
-  **NOTE:** *THREEBOND #2446 has been applied to bolts (9) (4 used).*
16. Remove the 5-spool Solenoid Valve Unit (2). (Refer to W3-12-2.)

## SECTION 3 UPPERSTRUCTURE

### Group 9 Control Valve

View A

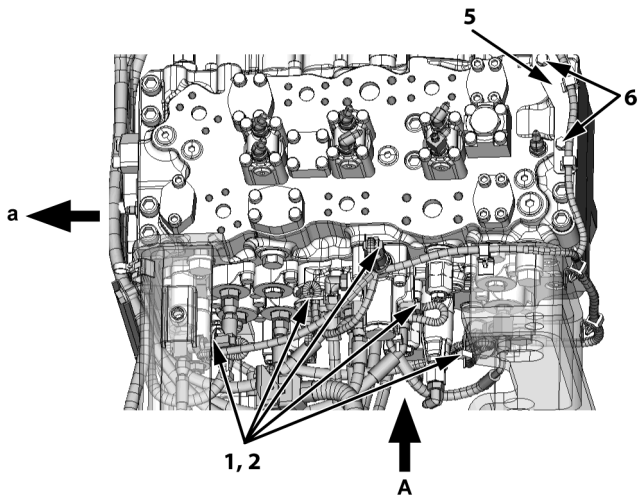

WDFX-03-09-016

a- Machine Front Side

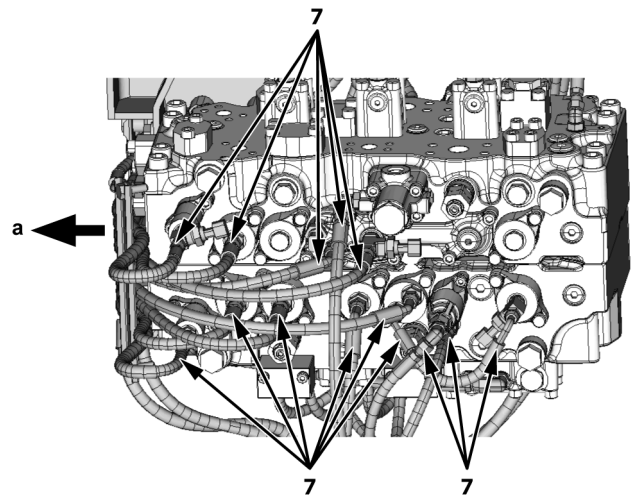



WDFX-03-09-017

a- Machine Front Side

4. Connect hoses (7) (14 used).

 : 17 mm

 : 25 N·m

 : 19 mm

 : 30 N·m

5. Connect connectors (1) (12 used). Install clip bands (2) (12 used).

6. Install bracket (5) with bolts, washers (6) (2 used).

 : 13 mm

 : 20 N·m

7. Install clip (4) with bolt, washer (3).

 : 17 mm

 : 50 N·m

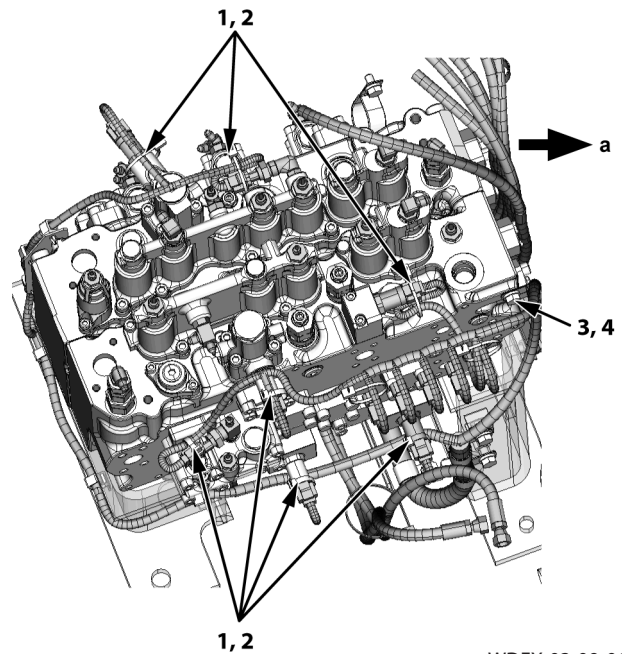

WDFX-03-09-015

a- Machine Front Side

## SECTION 3 UPPERSTRUCTURE

### Group 9 Control Valve

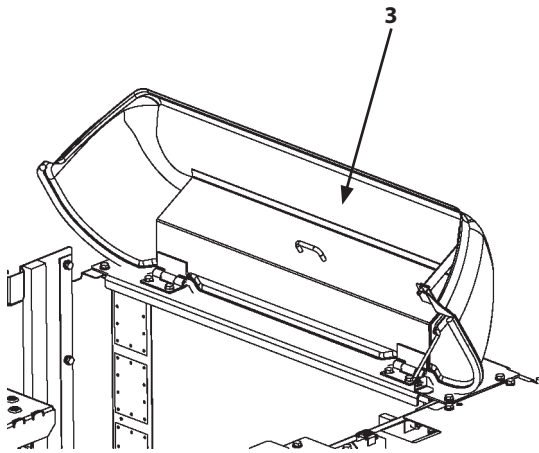

WDCX-03-04-005

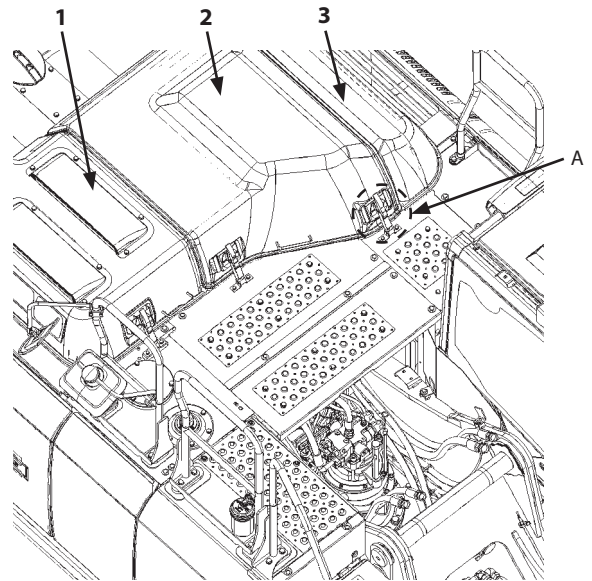

WDC4-03-02-151

48. Close engine cover (3).
49. Turn pin (4) by 90 degrees.
50. Close engine covers (1, 2).

Detail A

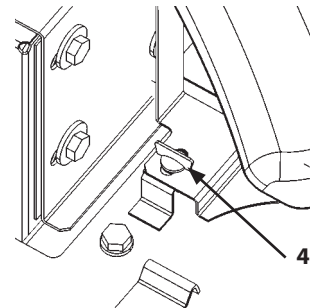

WDC4-03-02-152

CLICK HERE TO **DOWNLOAD** THE COMPLETE MANUAL

- Thank you very much for reading the preview of the manual.
- You can download the complete manual from: [www.heydownloads.com](http://www.heydownloads.com) by clicking the link below



- Please note: If there is no response to CLICKING the link, please download this PDF first and then click on it.

CLICK HERE TO **DOWNLOAD** THE COMPLETE MANUAL

## SECTION 3 UPPERSTRUCTURE

### Group 9 Control Valve

- Disassembly of Travel (Right) Spool (k)

12. Secure spool (3) in a vice by using wooden pieces. Remove bolt (165), spring seats (166) (2 used), and spring (167) from spool (3).

 : 8 mm

 **NOTE:** *LOCTITE #263 or equivalent has been applied to bolt (165).*

- Disassembly of Bucket Spool (1)

13. Secure spool (9) in a vice by using wooden pieces. Remove bolt (165), spring seats (166) (2 used), and spring (167) from spool (9).

 : 8 mm

 **NOTE:** *LOCTITE #263 or equivalent has been applied to bolt (165).*

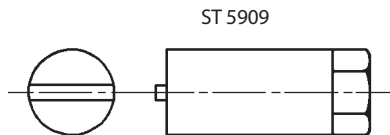

ST 5909

W157-02-05-049

14. Warm plug (175) part of spool (9) by using a dryer. Remove plug (175) by using special tool (ST 5909). Remove O-ring (173) and backup ring (174) from plug (175).

 **NOTE:** *LOCTITE #263 or equivalent has been applied to plug (175).*

15. Remove spring (172) and poppet (171) from spool (9).

- Disassembly of Bypass Cut Spool (m)

16. Secure spool (10) in a vice by using wooden pieces. Remove bolt (166), spring seats (166) (2 used), and spring (167) from spool (10).

 : 8 mm

 **NOTE:** *LOCTITE #263 or equivalent has been applied to bolt (165).*

- Disassembly of Boom 1 Spool (n)

17. Secure spool (11) in a vice by using wooden pieces. Remove bolt (165), spring seats (166) (2 used), and spring (167) from spool (11).

 : 8 mm

 **NOTE:** *LOCTITE #263 or equivalent has been applied to bolt (165).*

- Disassembly of Boom 2 Spool (o)

18. Secure spool (12) in a vice by using wooden pieces. Remove bolt (165), spring seats (166) (2 used), and spring (167) from spool (12).

 : 8 mm

 **NOTE:** *LOCTITE #263 or equivalent has been applied to bolt (165).*

19. Warm plug (177) part of spool (12) by using a dryer. Remove plug (177) by using special tool (ST 5909). Remove O-ring (173) and backup ring (174) from plug (177).

 **NOTE:** *LOCTITE #263 or equivalent has been applied to plug (177).*

20. Remove spring (172) and poppet (176) from spool (12).

## SECTION 3 UPPERSTRUCTURE

### Group 9 Control Valve

#### Assembly of Control Valve (A side)

**IMPORTANT: Before assembling, apply hydraulic oil onto parts in order to prevent them from seizing.**

- Assembly of Travel (Right) Spool (k)
  1. Apply LOCTITE #263 or equivalent to bolt (165). Secure spool (3) in a vice by using wooden pieces. Install spring seats (166) (2 used), spring (167), and bolt (165) to spool (3).

 : 8 mm

 : 15±1 N·m

- Assembly of Bucket Spool (1)
  2. Secure spool (9) in a vice by using wooden pieces. Install poppet (171) and spring (172) to spool (9).
  3. Install O-ring (173) and backup ring (174) to plug (175). Apply LOCTITE #263 or equivalent to the thread of plug (175).
  4. Install plug (175) to spool (9) by using special tool (ST 5909).

 : 15±1 N·m

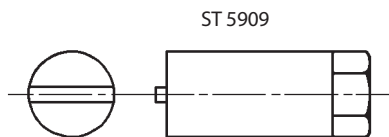

W157-02-05-049

5. Apply LOCTITE #263 or equivalent to bolt (165). Install spring seats (166) (2 used), spring (167), and spoolbolt (165) to spool (9).

 : 8 mm

 : 15±1 N·m

- Assembly of Bypass Cut Spool (m)
  6. Apply LOCTITE #263 or equivalent to bolt (165). Secure spool (10) in a vice by using wooden pieces. Install spring seats (166) (2 used), spring (167), and bolt (165) to spool (10).

 : 8 mm

 : 15±1 N·m

- Assembly of Boom 1 Spool (n)
  7. Apply LOCTITE #263 or equivalent to bolt (165). Secure spool (11) in a vice by using wooden pieces. Install spring seats (166) (2 used), spring (167), and bolt (165) to spool (11).

 : 8 mm

 : 15±1 N·m

## SECTION 3 UPPER STRUCTURE

### Group 9 Control Valve

- Disassembly of Load Check Valve (Arm Regeneration Circuit) (ac)

11. Remove plug (101), O-ring (219), spring (67), and poppet (68) from housing (2).

 : 10 mm

- Disassembly of Load Check Valve (Travel Left Tandem Circuit) (a)

12. Remove socket bolts (104) (2 used). Remove flange (34), O-ring (21), spring (22), and poppet (23) from housing (2).

 : 8 mm

- Disassembly of Check Valve (Main Relief Circuit) (b)

13. Remove socket bolts (104) (2 used). Remove flange (34), O-ring (114), spring (29), and poppet (30) from housing (2).

 : 8 mm

14. Remove plugs (100) (3 used) and O-rings (218) (3 used) on the load check valve (a) side and main relief valve (c) side from housing (2).

 : 8 mm

15. Remove plug (101) and O-ring (219) on the load check valve (a) side from housing (2).

 : 10 mm

16. Remove plugs (108) (2 used), backup ring (221) (2 used), and O-rings (220) (2 used) on main relief valve (80A) side from housing (2).

 : 24 mm

- Disassembly of Travel (Left) Spool (g)

17. Secure spool (3) in a vice by using wooden pieces. Remove bolt (222), spring seats (223) (2 used), and spring (224) from spool (3).

 : 8 mm

 NOTE: LOCTITE #263 or equivalent has been applied to bolt (222).

- Disassembly of Auxiliary 1 Spool (h)

18. Secure spool (4) in a vice by using wooden pieces. Remove bolt (222), spring seats (223) (2 used), and spring (224) from spool (4).

 : 8 mm

 NOTE: LOCTITE #263 or equivalent has been applied to bolt (222).

- Disassembly of Swing Spool (i)

19. Secure spool (5) in a vice by using wooden pieces. Remove bolt (222), spring seats (223) (2 used), and spring (224) from spool (5).

 : 8 mm

 NOTE: LOCTITE #263 or equivalent has been applied to bolt (222).

- Disassembly of Arm 2 Spool (j)

20. Secure spool (6) in a vice by using wooden pieces. Remove bolt (222), spring seats (223) (2 used), and spring (224) from spool (6).

 : 8 mm

 NOTE: LOCTITE #263 or equivalent has been applied to bolt (222).

- Disassembly of Arm 1 Spool (l)

21. Secure spool (7) in a vice by using wooden pieces. Remove bolt (222), spring seats (223) (2 used), and spring (224) from spool (7).

 : 8 mm

 NOTE: LOCTITE #263 or equivalent has been applied to bolt (222).

## SECTION 3 UPPER STRUCTURE

### Group 9 Control Valve

#### Assembly of Control Valve (B side)

**IMPORTANT: Before assembling, apply hydraulic oil onto parts in order to prevent them from seizing.**

- Assembly of Travel (Left) Spool (g)
  1. Apply LOCTITE #263 or equivalent to bolt (222).  
Secure spool (3) in a vice by using wooden pieces.  
Install spring seats (223) (2 used), spring (224), and bolt (222) to spool (3).

 : 8 mm

 : 15±1 N·m

- Assembly of Auxiliary 1 Spool (h)
  2. Apply LOCTITE #263 or equivalent to bolt (222).  
Secure spool (4) in a vice by using wooden pieces.  
Install spring seats (223) (2 used), spring (224), and bolt (222) to spool (4).

 : 8 mm

 : 15±1 N·m

- Assembly of Swing Spool (i)
  3. Apply LOCTITE #263 or equivalent to bolt (222).  
Secure spool (5) in a vice by using wooden pieces.  
Install spring seats (223) (2 used), spring (224), and bolt (222) to spool (5).

 : 8 mm

 : 15±1 N·m

- Assembly of Arm 2 Spool (j)
  4. Apply LOCTITE #263 or equivalent to bolt (222).  
Secure spool (6) in a vice by using wooden pieces.  
Install spring seats (223) (2 used), spring (224), and bolt (222) to spool (6).

 : 8 mm

 : 15±1 N·m

- Assembly of Arm 1 Spool (l)
  5. Apply LOCTITE #263 or equivalent to bolt (222).  
Secure spool (7) in a vice by using wooden pieces.  
Install spring seats (223) (2 used), spring (224), and bolt (222) to spool (7).

 : 8 mm

 : 15±1 N·m

- Assembly of Auxiliary 2 Spool (m)
  6. Apply LOCTITE #263 or equivalent to bolt (222).  
Secure spool (8) in a vice by using wooden pieces.  
Install spring seats (223) (2 used), spring (224), and bolt (222) to spool (8).

 : 8 mm

 : 15±1 N·m

- Assembly of Arm Regeneration Valve (k)
  7. Apply LOCTITE #263 or equivalent to bolt (225).  
Secure spool (20) in a vice by using wooden pieces.  
Install spring seats (227) (2 used), spring (226), and bolt (225) to spool (20).

 : 6 mm

 : 9.8 to 11.8 N·m

## SECTION 3 UPPER STRUCTURE

### Group 10 Swing Device

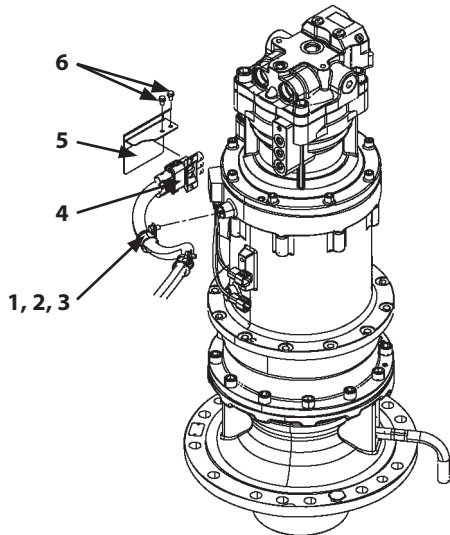

WDFM-03-10-001

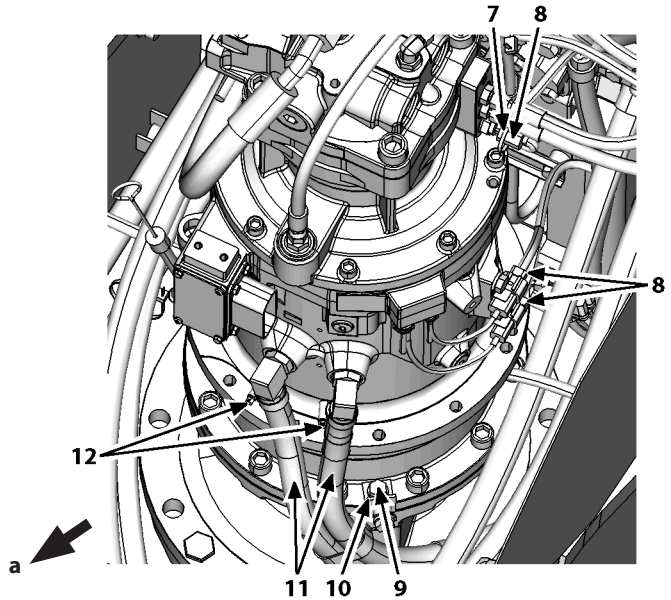

WDFM-03-10-002

a- Machine Front Side

11. Remove bolt, washer (1). Remove clamp (2) and rubber (3).

 : 17 mm

12. Remove bolts, washers (6) (2 used). Remove cover (5).

 : 13 mm

13. Disconnect connector (4).

14. Remove clip band (7). Disconnect connectors (8) (3 used).

15. Remove bolt, washer (9).

 : 17 mm

16. Remove clamps (12) (2 used). Disconnect hoses (11) (2 used) and the bracket (10) assembly.

17. Remove the swing low-pressure relief valve unit. (Refer to W6-4-1.)

## SECTION 3 UPPER STRUCTURE

### Group 10 Swing Device

**CAUTION:** Swing hydraulic motor (11) weight : 53 kg

8. Remove drain plug (22) and O-ring (23). Drain hydraulic oil from space between swing hydraulic motor (11) and swing electric motor (00).

 : 8 mm

9. Install O-ring (23) to drain plug (22). Install drain plug (22) to swing electric motor (00).

 : 8 mm

 : 24 N·m

10. Remove socket bolts (12) (8 used). Install eyebolts (M10, pitch 1.5 mm) (2 used) to swing hydraulic motor (11). Insert a screwdriver to notch part of outer surface of jointed part. Hoist and remove swing hydraulic motor (11) from swing electric motor (00).

 : 10 mm

**NOTE:** LOCTITE #1215 or LOCTITE #5020 has been applied to the mating surface.

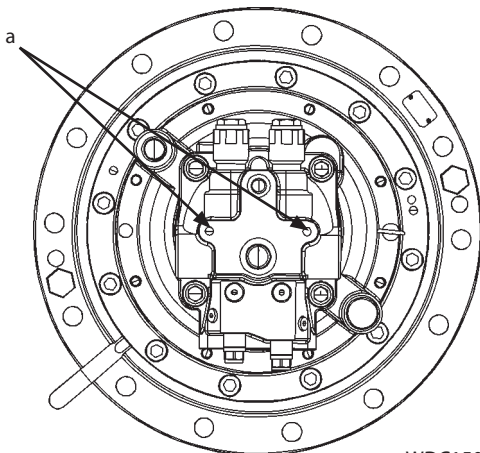

WDC150-03-10-007

a- Eyebolt Mounting Hole

11. Remove O-ring (14) from swing electric motor (00).
12. Remove socket bolts (03) (11 used) and washers (13) (11 used).

 : 10 mm

**CAUTION:** Swing electric motor (00) weight: 72 kg

13. Install eyebolts (M12, pitch 1.75 mm) (2 used) to swing hydraulic motor (11) mounting screw part of swing electric motor (00). Hoist and hold it.

14. Install bolts (M10, pitch 1.5 mm) (2 used) to bolt holes (b) (2 places) of swing electric motor (00). Raise swing electric motor (00) by turning the bolts. Hoist and remove swing hydraulic motor (00) from swing reduction gear (02).

**NOTE:** LOCTITE #1215 or LOCTITE #5020 has been applied to the mating surface.

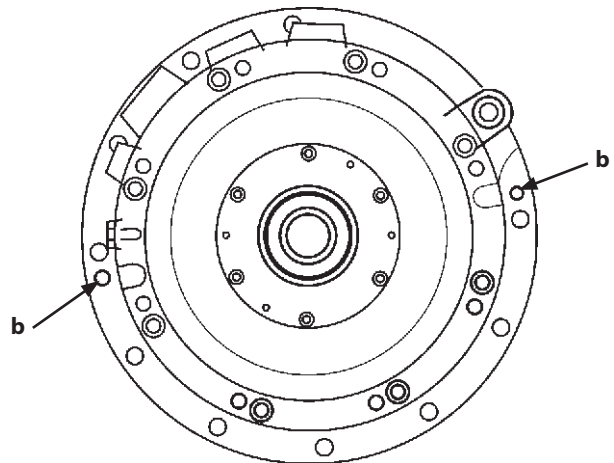

WDCF-03-10-008

b- Screw Hole

15. Remove retaining ring (01) from swing electric motor (00).

## SECTION 3 UPPERSTRUCTURE

### Group 10 Swing Device

#### Assembly of Swing Reduction Gear

**IMPORTANT:** Before assembling, apply gear oil onto parts in order to prevent them from seizing.

1. Install O-ring (30) to sleeve (29).

**CAUTION:** Shaft (31) assembly weight: 43 kg

2. Install sleeve (29) and inner race of roller bearing (27) to shaft (31) by using special tool (ST 4149) and a press.

**NOTE:** The press-in distance of the inner race can be assured by using special tool (ST 4149).

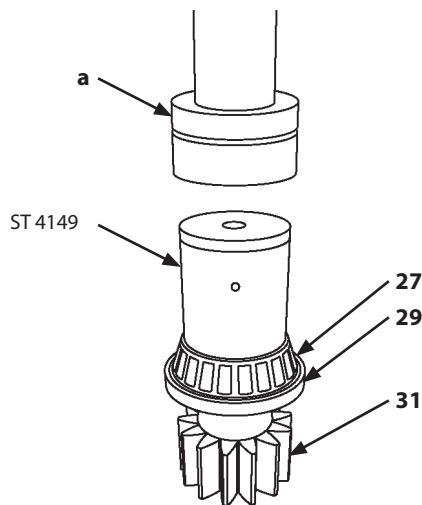

a- Press

**CAUTION:** Housing (26) weight: 58 kg

3. Attach a nylon slings to the body of housing (26). Hoist and place housing (26) with sleeve (29) side up.

**CAUTION:** Metal fragments may fly off when a hammer is used. Wear necessary protection, such as goggles, hard hats, etc. in order to prevent personal injury.

4. Evenly tap and install the outer race of roller bearing (27) to housing (26) by using a bar and a hammer. Tap and listen to ring in order to check if the installation is completed.

**CAUTION:** Metal fragments may fly off when a hammer is used. Wear necessary protection, such as goggles, hard hats, etc. in order to prevent personal injury.

5. Apply THREEBOND #1215 or LOCTITE #5020 to the outer surface of oil seal (28). Place oil seal (28) on housing (26) in level, and then slightly push it in. Place special tool (ST 2925) on oil seal (28). Install special tool (ST 2925) straight in by using a hammer.

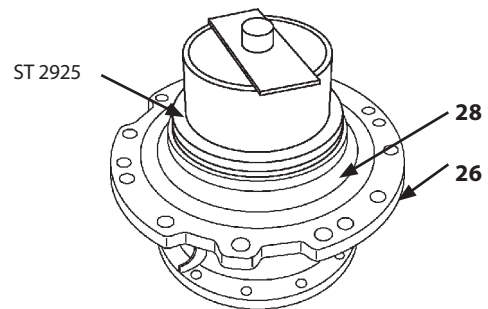

W178-02-11-144

6. Thoroughly apply grease to the inner surface of oil seal (28). Apply grease to the outer surface of sleeve (29) that is attached to shaft (31). Apply grease carefully when installing shaft (31) in order not to curl the lip.

## SECTION 3 UPPERSTRUCTURE

### Group 10 Swing Device

---

#### Assembly of Swing Hydraulic Motor

**IMPORTANT:** Before assembling, apply hydraulic oil onto parts in order to prevent them from seizing.

1. Install the inner race of bearing (3, 22) to shaft (4) by using a press. Install the inner race of bearing (3) with the flange part facing toward the stepped part of shaft (4).
2. Install oil seal (2) to casing (1) with its lip part side up using a plate.

**⚠ CAUTION:** Metal fragments may fly off when a hammer is used. Wear necessary protection, such as goggles, hard hats, etc. in order to prevent personal injury.

3. Install the outer race of bearing (3) to casing (1) by using a bar and a hammer.

**⚠ CAUTION:** Casing (1) assembly weight: 21 kg

4. Install a tape onto the spline at the end of shaft (4) in order not to damage oil seal (2). Place the casing (1) assembly horizontally. Install shaft (4) to casing (1).

**⚠ CAUTION:** Casing (1) assembly weight: 21 kg

5. Place casing (1) assembly with valve casing (28) mounting surface up. Install shoe plate (5) to casing (1) with the chamfered surface facing the backside.
6. Align the notches of plate (7) and the retainer (8). Install plungers (6) (9 used). Install retainer (8) to plunger (6) with the notch facing toward shoe plate (5) side.
7. Apply hydraulic oil to plunger hole of rotor (9). Install the plunger (6) assembly to rotor (9).

**⚠ CAUTION:** Casing (1) assembly weight: 21 kg

8. Place the casing (1) assembly horizontally. Install the rotor (9) assembly to shaft (4).

**IMPORTANT:** Plate (10) has four notch parts at the outer side. Friction plate (11) has four notches at the tooth of spline side.

**⚠ CAUTION:** Casing (1) assembly weight: 23 kg

9. Place the casing (1) assembly vertically. Install plates (10) (4 used) and friction plates (11) (3 used) in one by one alternately in order to align each notch with the same place.
10. Install O-rings (17, 18) to casing (1).
11. Install brake piston (19) to casing (1) with the mating marks aligned.

**✎ NOTE:** Tap brake piston (19) evenly by using a plastic hammer when it is difficult to insert brake piston (19) due to resistance force of O-rings (17, 18).

12. Install springs (20) (24 used) to brake piston (19).

## SECTION 3 UPPERSTRUCTURE

### Group 11 Pilot Valve

---

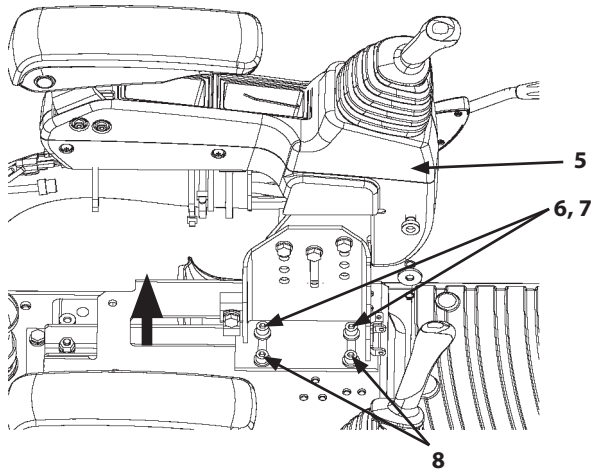

WDCX-03-01-006

18. Fully move the left console (5) assembly outward. Install washers (7) (2 used) and socket bolts (6) (2 used).

 : 8 mm

 : 50 N·m

19. Tighten socket bolts (8) (2 used).

 : 8 mm

 : 50 N·m

## SECTION 3 UPPERSTRUCTURE

### Group 11 Pilot Valve

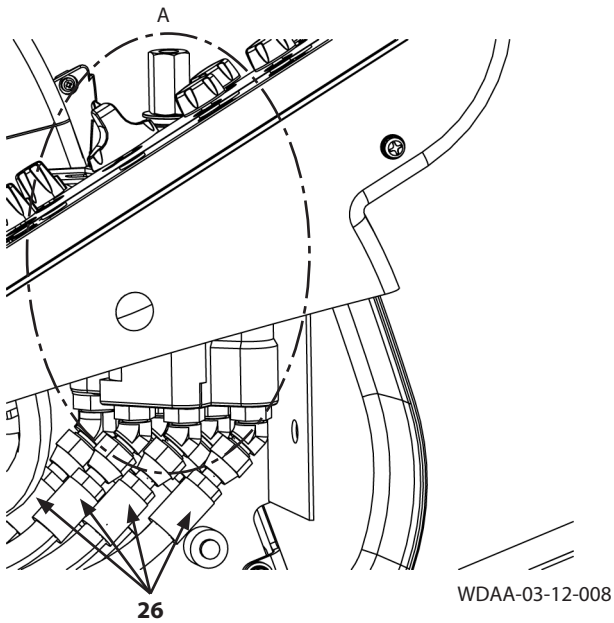

Detail A

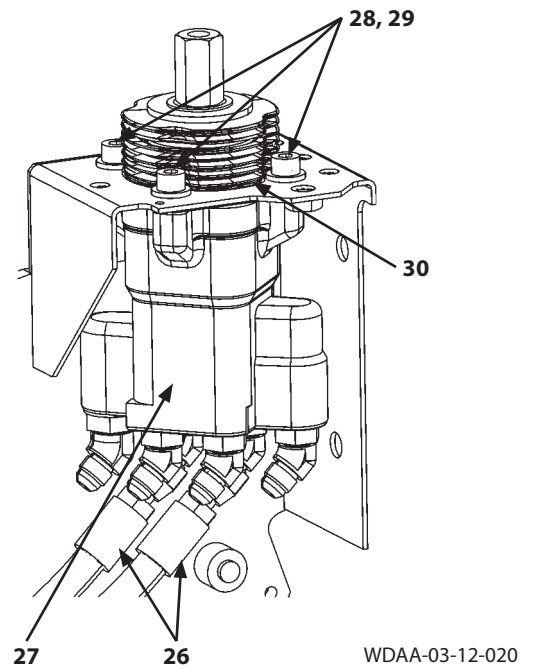

19. Disconnect hoses (26) (6 used).

 : 19 mm

20. Remove socket bolts (28) (4 used) and washers (29) (4 used). Remove pilot valve (27) and boot (30).

 : 6 mm

21. Remove the adapters with pilot valve (27) attached if necessary.

## SECTION 3 UPPERSTRUCTURE

### Group 11 Pilot Valve

#### Removal and Installation of Travel Pilot Valve

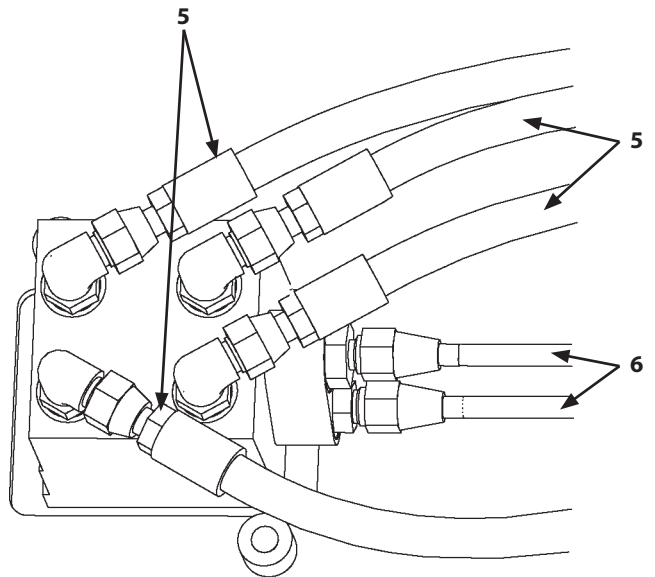
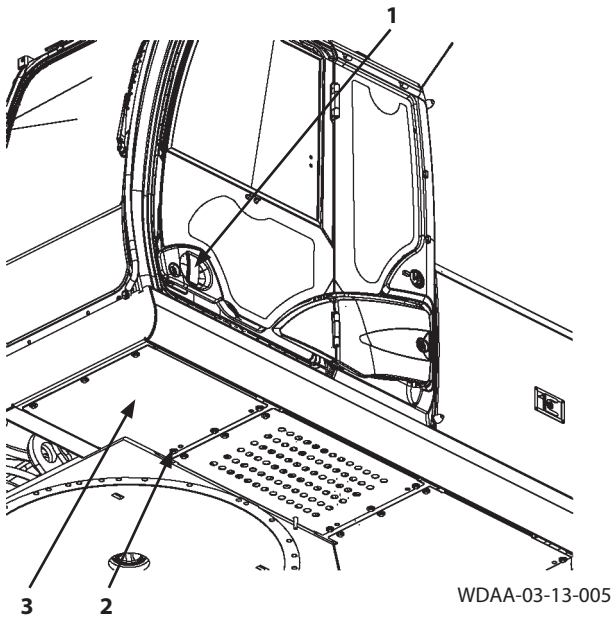

**IMPORTANT:** The hoses and pipes contain hydraulic oil. When removing the hoses and pipes, receive oil with a container in order to avoid spilling oil.

**IMPORTANT:** Cap the open ends in case the hoses and pipes have been disconnected. In addition, attach identification tags onto the connectors, hoses, and pipes for assembling. If the clips which secure the hoses have been removed, install the clips after connecting the hoses.

#### Removal

1. Swing the upperstructure by 90 degrees and set the machine position for inspection and maintenance. (Refer to W1-5-1.)

**CAUTION:** Release any pressure in the hydraulic oil tank. (Refer to W1-5-1.)

2. Open door (1).
3. Remove the floor mat.

**CAUTION:** Remove cover (3) while holding it. Do not drop cover (3).

4. Remove bolts, washers (2) (6 used). Remove cover (3).

 : 17 mm

5. Disconnect hoses (5) (4 used).

 : 19 mm

6. Disconnect pipes (6) (2 used).

 : 17 mm

# SECTION 3 UPPERSTRUCTURE

## Group 11 Pilot Valve

### Disassembly of Travel Pilot Valve

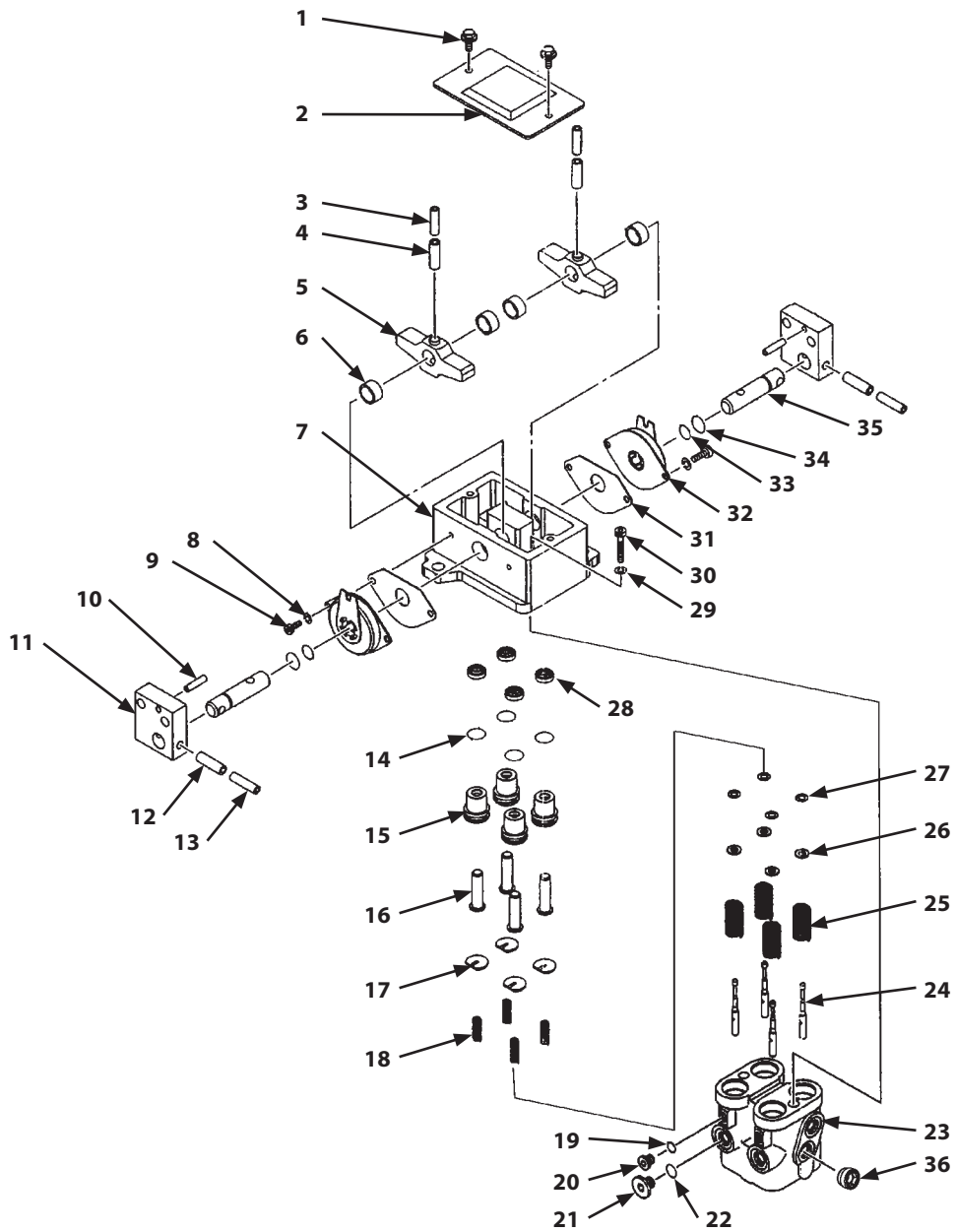

WDA-03-12-024

- |                           |                             |                     |                            |
|---------------------------|-----------------------------|---------------------|----------------------------|
| 1- Bolt, Washer (2 Used)  | 10- Spring Pin (2 Used)     | 19- O-Ring (2 Used) | 28- Oil Seal (4 Used)      |
| 2- Cover                  | 11- Bracket (2 Used)        | 20- Plug (2 Used)   | 29- Spring Washer (2 Used) |
| 3- Spring Pin (2 Used)    | 12- Spring Pin (2 Used)     | 21- Plug (2 Used)   | 30- Socket Bolt (2 Used)   |
| 4- Spring Pin (2 Used)    | 13- Spring Pin (2 Used)     | 22- O-Ring (2 Used) | 31- Rubber Seat (2 Used)   |
| 5- Cam (2 Used)           | 14- O-Ring (4 Used)         | 23- Casing          | 32- Damper (2 Used)        |
| 6- Bushing (4 Used)       | 15- Bushing (4 Used)        | 24- Spool (4 Used)  | 33- O-Ring (2 Used)        |
| 7- Holder                 | 16- Pusher (4 Used)         | 25- Spring (4 Used) | 34- O-Ring (2 Used)        |
| 8- Spring Washer (4 Used) | 17- Spring Guide (16 Used)  | 26- Spacer (4 Used) | 35- Pin (2 Used)           |
| 9- Socket Bolt (4 Used)   | 18- Balance Spring (4 Used) | 27- Shim (12 Used)  | 36- Filter                 |

## SECTION 3 UPPER STRUCTURE

### Group 12 Solenoid Valve

#### Removal and Installation of Pilot Shut-Off Solenoid Valve

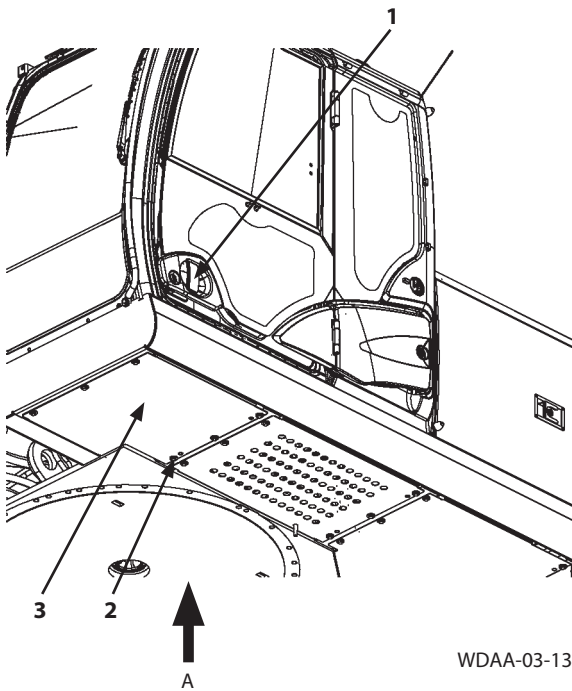

WDAA-03-13-005

View A

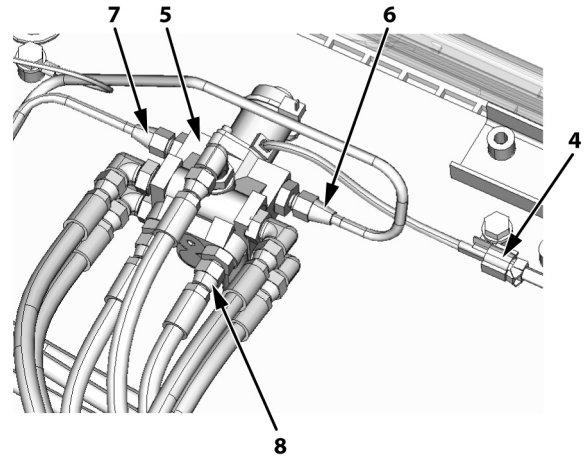

WDFX-03-12-004

**IMPORTANT:** The hoses and pipes contain hydraulic oil. When removing the hoses and pipes, collect the oil in a container in order to avoid spilling oil.

**IMPORTANT:** Cap the open ends in case the hoses and pipes have been disconnected. In addition, attach identification tags onto the connectors, hoses, and pipes for assembling. If the clips that secure the hoses have been removed, install the clips after connecting the hoses.

#### Removal

1. Turn the machine 90 degrees to set the position for inspection and maintenance. (Refer to W1-5-1.)

**CAUTION:** Release any pressure from the hydraulic oil tank. (Refer to W1-5-1.)

2. Open door (1).
3. Remove floor mats.

**CAUTION:** Remove cover (3) while supporting it. Do not drop cover (3).

4. Remove bolts, washers (2) (6 used). Remove cover (3).

 : 17 mm

5. Disconnect connector (4).

6. Disconnect both ends of pipe (6, 7).

 : 17 mm

7. Disconnect hoses (8) (7 used).

 : 19 mm

## SECTION 3 UPPERSTRUCTURE

### Group 12 Solenoid Valve

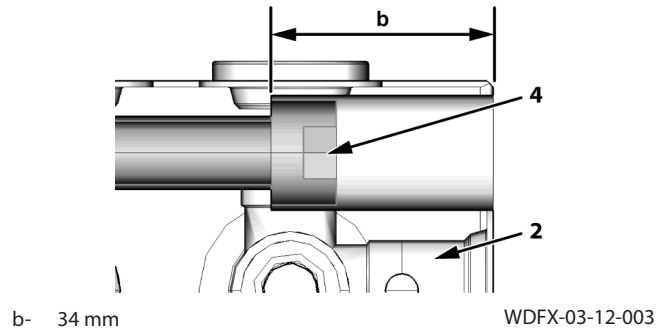

- a- Machine Front Side
- b- 45°

#### Installation

1. Attach all removed adapters to the 3-spool solenoid valve (2).
2. Install the 3-spool solenoid valve unit (2) to bracket (1) with socket bolts (4) (2 used).

 : 8 mm

 : 50 N·m

3. Connect hoses (3) (9 used) to the 3-spool solenoid valve unit (2).

 : 19 mm

 : 30 N·m

4. Connect connectors (8) (6 used).
5. Install bolt, washer (6) and clip (7).

 : 17 mm

 : 50 N·m

6. Install clip bands (5) (3 used).

## SECTION 3 UPPERSTRUCTURE

### Group 13 Signal Control Valve

#### Removal and Installation of Signal Control Valve

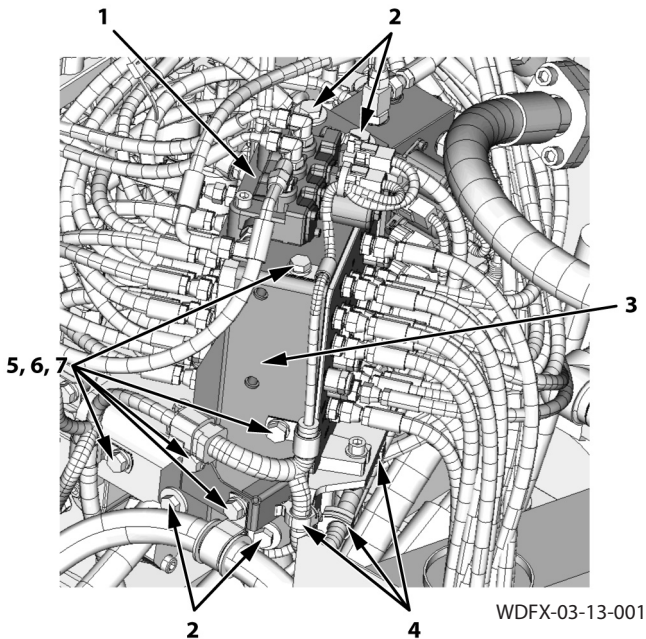

**IMPORTANT:** The hoses and pipes contain hydraulic oil. When removing the hoses and pipes, collect the oil in a container in order to avoid spilling oil.

**IMPORTANT:** Cap the open ends in case the hoses and pipes have been disconnected. In addition, attach identification tags onto the connectors, hoses, and pipes for assembling. Install clip bands after connecting hoses if the clips that bundle the hoses were removed.

#### Removal

1. Remove the Swing Control Solenoid Valve Unit (1). (Refer to W6-3-1.)
2. Remove bolts, washers (5) (5 used), clips (6) (4 used), and bracket (7).

 : 17 mm

3. Remove clips (4) (3 used).
4. Loosen bolts, washers (2) (4 used). Remove bracket (3).

 : 17 mm

## SECTION 3 UPPERSTRUCTURE

### Group 14 Muffler Filter

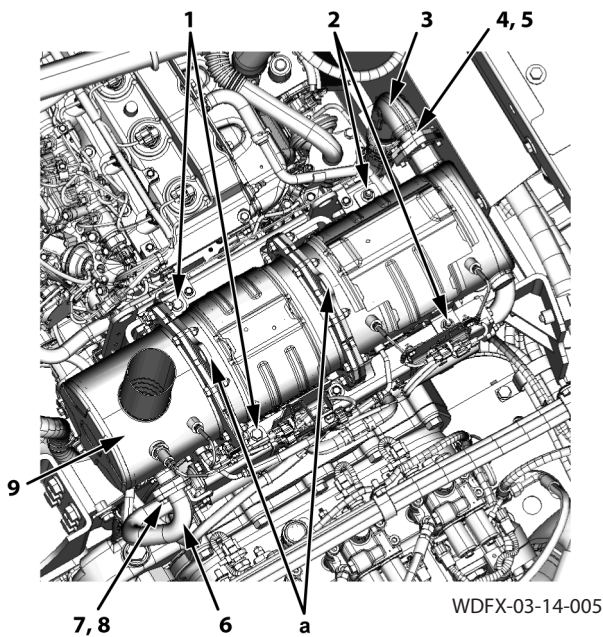

a- Lifting Hole

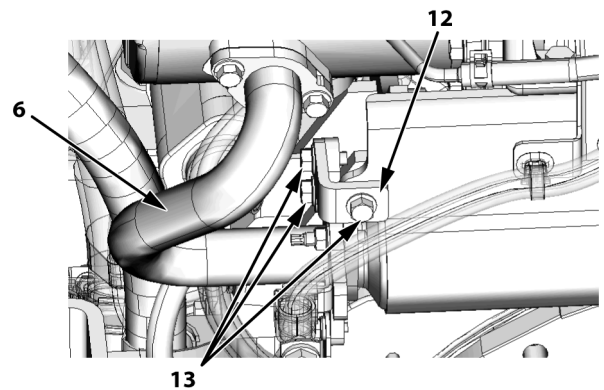
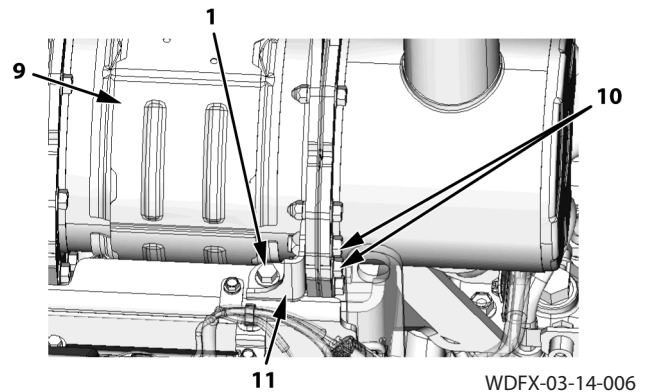

**CAUTION:** Bolts (4, 7) and gaskets (5, 8) cannot be re-used.

11. Remove bolts (4) (3 used). Disconnect turbine outlet elbow (3).

 : 12 mm

12. Remove bolts (7) (2 used). Disconnect EGR pipe (6).

 : 12 mm

13. Remove bolts (13) (3 used). Remove Stay (12).

 : 12 mm

**CAUTION:** Muffler filter (9) assembly weight: 21.5 kg

14. Remove bolts (1) (2 used) and nuts (2) (2 used). Attach the nylon slings to lifting holes (2 places). Remove the muffler filter (9) assembly. Remove gaskets (5, 8).

 : 14 mm

**CAUTION:** Bolt (10) and stay (11) are not necessary to be removed when the muffler filter is not disassembled and is re-assembled.

15. Remove bolts (10) (4 used). Remove stays (11) (2 used).

 : 14 mm

## SECTION 4 UNDERCARRIAGE

### Group 1 Swing Bearing

#### Removal and Installation of Swing Bearing

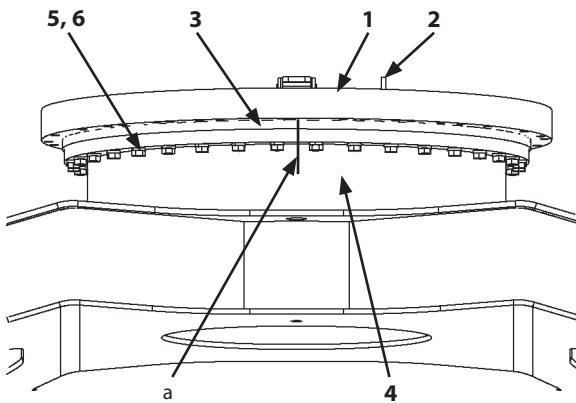

a- Matching Mark

WDBF-04-01-001

Before removing and installing the swing bearing, the upperstructure must be removed first. (Refer to W3-3-1.) Therefore, the procedure starts on the premise that the upperstructure has already been removed here.

#### Removal

1. Put matching marks (a) on inner race (3) of swing bearing (1) and track frame (4).
2. Remove knock pin (2).
3. Remove bolts (5) (36 used) and washers (6) (36 used).

 : 30 mm

## SECTION 4 UNDERCARRIAGE

### Group 1 Swing Bearing

#### Assembly of Swing Bearing

**CAUTION:** Swing bearing weight: 330 kg

1. Install the special tools (ST 0050) (3 used) to outer race (1). Attach wire ropes onto the special tools (ST 0050) (3 used). Hoist the swing bearing horizontally. Align outer race (1) and inner race (7) coaxially.

Apply grease to balls (6) (99 used) and supports (8) (99 used).

Install balls (6) (99 used) and supports (8) (99 used) alternately from the plug (4) hole by using a round bar while turning outer race (1).

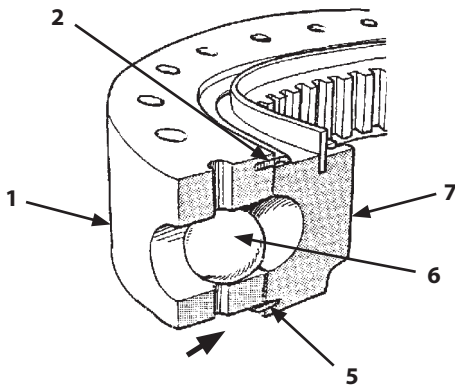

W178-02-11-199

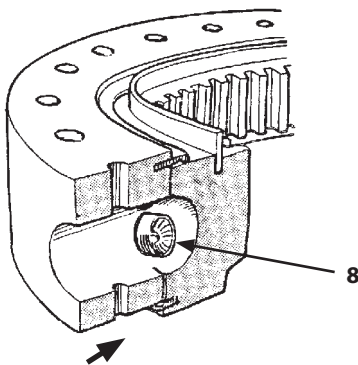

W178-02-11-200

**CAUTION:** Metal fragments may fly off when a hammer is used. Wear necessary protection, such as goggles, hard hat, etc. in order to prevent personal injury.

2. Install plug (4) to outer race (1) by using a hammer. Secure plug (4) to outer race (1) with pin (3). Crimp the head of pin (3) by using a punch.

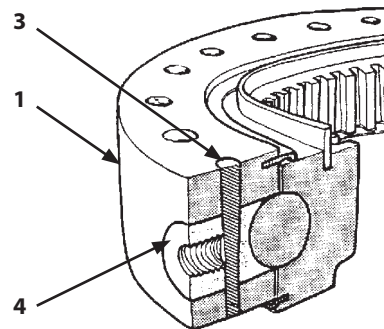

W178-02-11-201

3. Degrease the groove part for seals (2, 5) completely. Apply THREEBOND #1530D to seals (2,5). Install seals (2, 5) to outer race (1) and inner race (7).
4. Add grease (Alvania EP2 or equivalent) to the swing bearing through grease fittings (9) (2 used). At this time, add grease while turning outer race (1).

**NOTE:** Grease amount: 0.7L

# SECTION 4 UNDERCARRIAGE

## Group 2 Travel Device

### Assembly of Travel Device

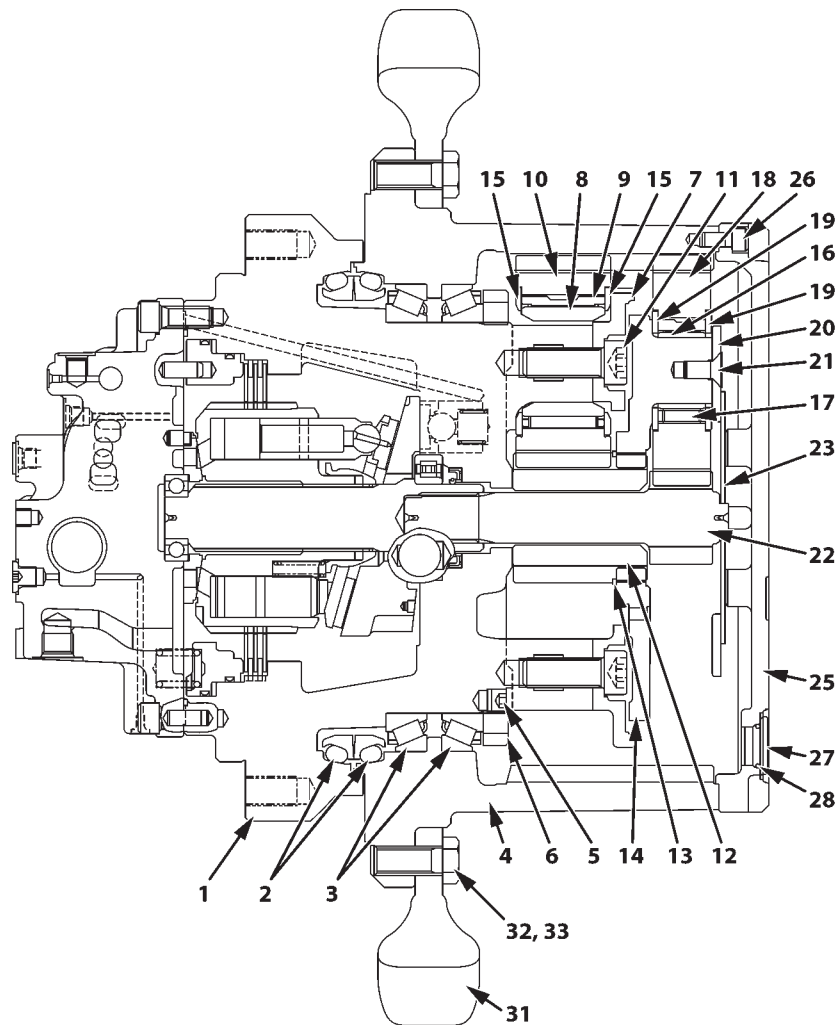

WDFX-04-02-016

- |                            |                             |                             |                             |
|----------------------------|-----------------------------|-----------------------------|-----------------------------|
| 1- Travel Motor            | 9- Needle Bearing (3 Used)  | 17- Needle Bearing (3 Used) | 26- Socket Bolt (20 Used)   |
| 2- Floating Seal (2 Used)  | 10- Planetary Gear (3 Used) | 18- Planetary Gear (3 Used) | 27- Plug (3 Used)           |
| 3- Roller Bearing (2 Used) | 11- Bolt (6 Used)           | 19- Thrust Plate (6 Used)   | 28- O-Ring (3 Used)         |
| 4- Ring Gear               | 12- Sun Gear                | 20- Thrust Plate            | 31- Sprocket                |
| 5- Plug (3 Used)           | 13- Ring                    | 21- Screw (3 Used)          | 32- Bolt (18 Used)          |
| 6- Bearing Nut             | 14- First Stage Carrier     | 22- Shaft                   | 33- Spring Washer (18 Used) |
| 7- Holder                  | 15- Thrust Plate (6 Used)   | 23- Thrust Plate            |                             |
| 8- Inner Race (3 Used)     | 16- Inner Race (3 Used)     | 25- Cover                   |                             |

## SECTION 4 UNDERCARRIAGE

### Group 2 Travel Device

---

8. Remove D-rings (15, 16) from brake piston (14).
9. Remove plates (12) (3 used) and friction plates (13) (2 used) from housing (1).
10. Remove rotor (31), springs (35) (9 used), bushing (34), retainer (33), and plungers (32) (9 used) from housing (1).
11. Remove swash plate (5) from housing (1).
12. Remove balls (6) (2 used), pistons (7) (2 used), and springs (20) (2 used) from housing (1) by using a magnet.
13. Remove shaft (3) and roller bearing (8) from housing (1).

**IMPORTANT: Do not remove the outer part of roller bearing (8) nor oil seal (11) unless necessary.**

# SECTION 4 UNDERCARRIAGE

## Group 2 Travel Device

### Precautions for Using Floating Seal

1. In general, replace the floating seal with a new one after disassembling.

If the floating seal is required to be reused, follow these procedures:

- Keep seal rings together as a matched set with seal ring (1) surfaces together. Apply oil onto sliding surface (e) of seal ring (1).
- Check sliding surface (e) of seal ring (1) for scuffing, scoring, corrosion, deformation, or uneven wear. Check the step part of seal ring (1).
- Check O-ring (2) for tears, breaks, deformation, or hardening.

2. If incorrectly assembled, oil leakage or damage will occur. Be sure to do the following to prevent trouble.

- Clean the floating seal and seal mounting bores with cleaning solvent.

Use a wire brush to remove mud, rust, or dirt from seal mounting bores. After cleaning, thoroughly dry parts with compressed air.

- Clean seal ring (1) and O-ring (2) mounting bores. Check the bore surface for scuffing or scoring by touching the surface with finger.
- After installing the floating seal, check that O-ring (2) is not twisted, and that it is installed correctly on seal ring (1).
- After installing the floating seal, check that O-ring (2) and seal ring sliding surface (e) is parallel with seal mating surface (f) by measuring the distances (e) and (f) at point (A) and (B), as illustrated. If these distances differ, correct O-ring (2) seating.

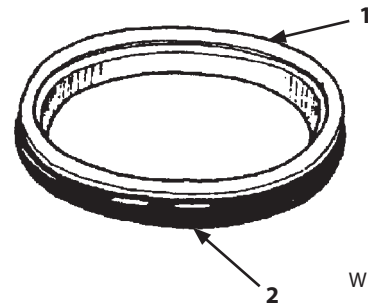

W178-02-11-001

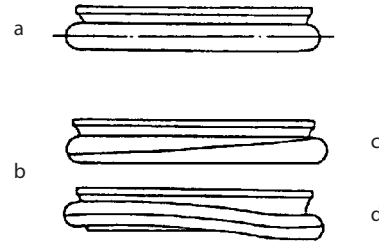
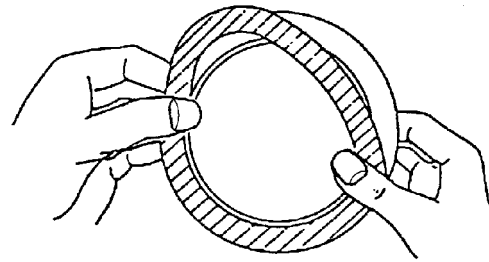

W178-02-11-002

- a - Correct
- b - Incorrect
- c - Twist of O-Ring
- d - Bend of O-Ring

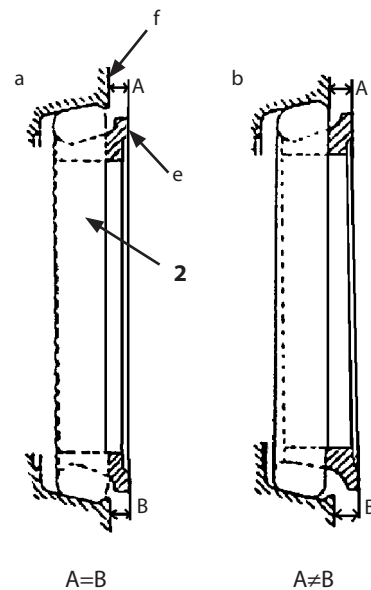

W178-02-11-003

- a - Correct
- b - Incorrect
- e - Sliding Surface
- f - Seal Mating Surface

## SECTION 4 UNDERCARRIAGE

### Group 3 Center Joint

---

**IMPORTANT:** Install ring (06) with the chamfered surface facing to the spindle (00A) side.

4. Install ring (06) and O-ring (08) to body (01).

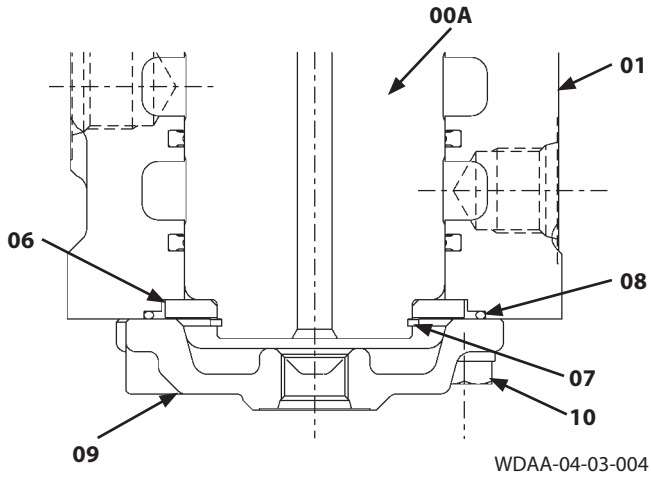

5. Install retaining ring (07) to spindle (00A).
6. Install cover (09) to body (01) with bolts, washers (10) (4 used).

 : 17 mm

 : 50 N·m

## SECTION 4 UNDERCARRIAGE

### Group 4 Track Adjuster

#### Assembly of Front Idler

**CAUTION:** Idler (03A) weight: 70 kg

1. Install bushings (03B) (2 used) to idler (03A).
2. Place axle (01) vertically. Install O-ring (02) to the upper side of axle (01).
3. Fit the matching marks made when disassembling and install bearing (00) to axle (01) by using a plastic hammer.

**CAUTION:** Metal fragments may fly off when a hammer is used. Wear necessary protection, such as goggles, hard hat, etc. in order to prevent personal injury.

4. Install pin (04) by using a bar and a hammer.

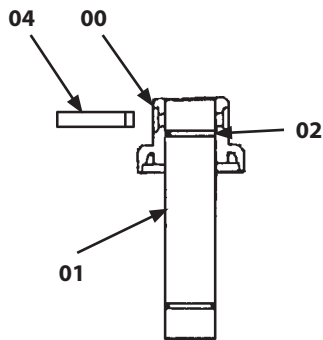

WDDQ50-04-04-001

**IMPORTANT:** Handle floating seal (05) with care. (Refer to W4-4-4.)

5. Apply engine oil to the O-ring of floating seal (05). Install floating seal (05) to idler (03A) and bearing (00).

**CAUTION:** The axle (01) assembly weight: 25 kg

6. Attach nylon slings onto bearing (00) of the axle (01) assembly. Hoist the axle (01) assembly. Install the axle (01) assembly to idler (03A) at the side where floating seal (05) has been installed.

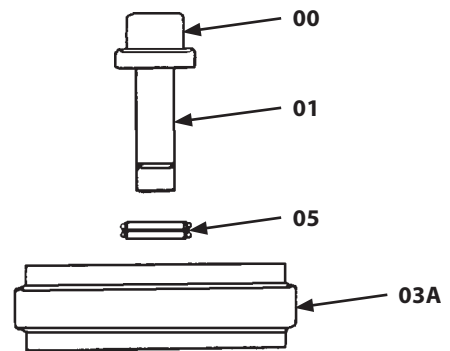

WDDQ50-04-04-002

7. Install a seal tape onto the thread part of plug (06). Install plug (06) to bearing (00).

 : 6 mm

 : 15 N·m

# SECTION 4 UNDERCARRIAGE

## Group 4 Track Adjuster

### Precautions for Using Floating Seal

1. In general, replace the floating seal with a new one after disassembling.

If the floating seal is required to be reused, follow these procedures:

- Keep seal rings together as a matched set with seal ring (1) surfaces together. Apply oil onto sliding surface (e) of seal ring (1).
  - Check sliding surface (e) of seal ring (1) for scuffing, scoring, corrosion, deformation, or uneven wear. Check the step part of seal ring (1).
  - Check O-ring (2) for tears, breaks, deformation, or hardening.
2. If incorrectly assembled, oil leakage or damage will occur. Be sure to do the following to prevent trouble.
- Clean the floating seal and seal mounting bores with cleaning solvent. Use a wire brush to remove mud, rust, or dirt from seal mounting bores. After cleaning, thoroughly dry parts with compressed air.
  - Clean seal ring (1) and O-ring (2) mounting bores. Check the bore surface for scuffing or scoring by touching the surface with finger.
  - After installing the floating seal, check that O-ring (2) is not twisted, and that it is installed correctly on seal ring (1).
  - After installing the floating seal, check that O-ring (2) and seal ring sliding surface (e) is parallel with seal mating surface (f) by measuring the distances (e) and (f) at point (A) and (B), as illustrated. If these distances differ, correct O-ring (2) seating.

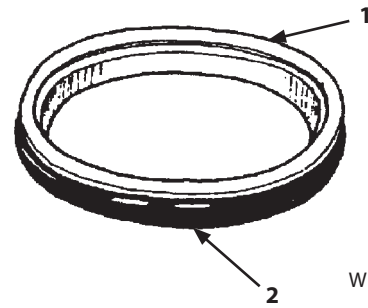

W178-02-11-001

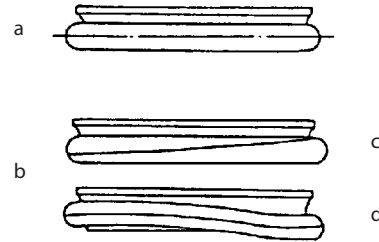
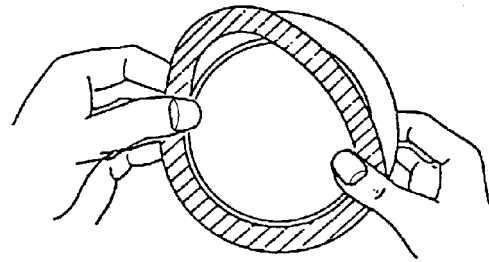

W178-02-11-002

- a - Correct
- b - Incorrect
- c - Twist of O-Ring
- d - Bend of O-Ring

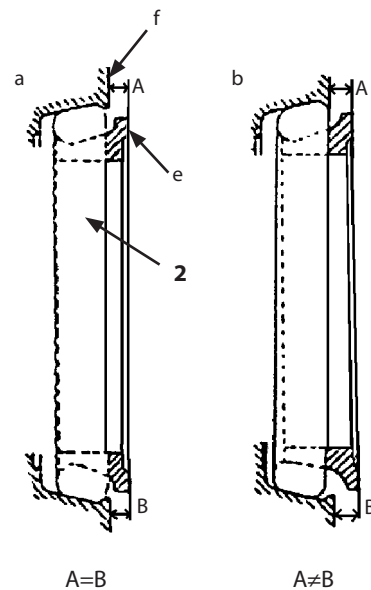

W178-02-11-003

- a - Correct
- b - Incorrect
- e - Sliding Surface
- f - Seal Mating Surface

## SECTION 4 UNDERCARRIAGE

### Group 6 Upper and Lower Rollers

---

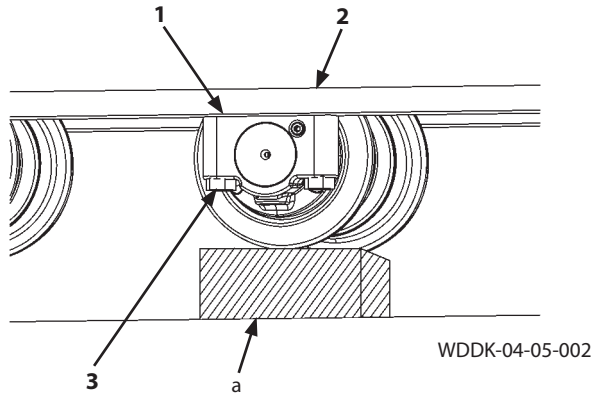

a - Wooden Block

- Put the matching marks on lower roller (1) and track frame (2).

**⚠ CAUTION: When removing bolt (3) without holding lower roller (1), lower roller (1) will fall down.**

- Place wooden block (a) under lower roller (1).
- Remove bolts (3) (4 used).

 : 27 mm

- ⚠ CAUTION: Lower roller (1) weight: 35 kg**
- Remove lower roller (1) by using a forklift.

## SECTION 4 UNDERCARRIAGE

### Group 7 Track

#### Removal and Installation of Track

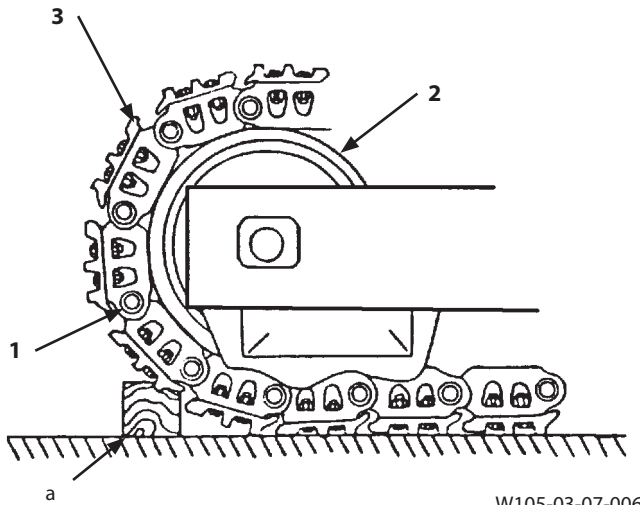

W105-03-07-006

a- Wooden Block

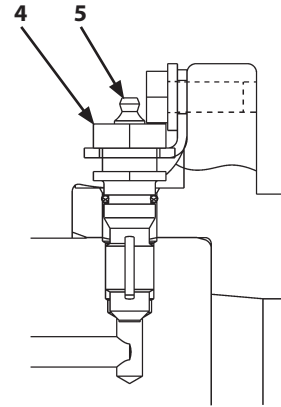

WDCD-04-06-001

#### Removal

1. Set the machine position for inspection and maintenance. (Refer to W1-5-1.)
2. Turn the track so that master pin (1) is positioned over front idler (2). Place wooden block (a) under shoe (3) to support shoe (3).

**CAUTION:** Do not remove bracket (6). Do not loosen bolt (7) for adjustment.

**CAUTION:** Pressure inside the cylinder of the track adjuster is high. Do not loosen valve (4) quickly or too much as valve (4) may fly out or high-pressure grease may spout out. Keep body parts and face away from valve (4) and loosen it gradually. Do not loosen grease fitting (5).

**IMPORTANT:** Loosening valve (4) by 1 to 1.5 turns is enough. Do not loosen valve (4) over those turns.

**IMPORTANT:** When gravel or mud is packed between the sprocket and track links, remove it before loosening.

3. Loosen valve (4). Drain grease and loosen the track.

 : 24 mm

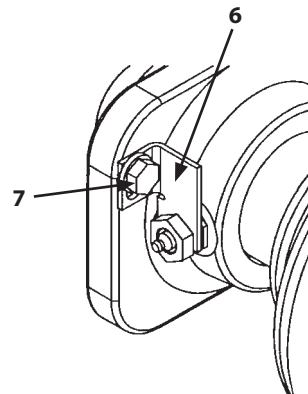

MDAA-07-057

---

---

## SECTION 5

# FRONT ATTACHMENT

### CONTENTS

#### Group 1 Front Attachment

Removal and Installation of Front Attachment...W5-1-1-1

#### Group 2 Cylinder

Removal and Installation of Boom Cylinder.....W5-2-1-1

Removal and Installation of Arm Cylinder .....W5-2-2-1

Removal and Installation of Bucket Cylinder .....W5-2-3-1

Disassembly of Boom, Arm, and Bucket

    Cylinders.....W5-2-5-1

Assembly of Boom, Arm, and Bucket

    Cylinders.....W5-2-5-7

## SECTION 5 FRONT ATTACHMENT

### Group 1 Front Attachment

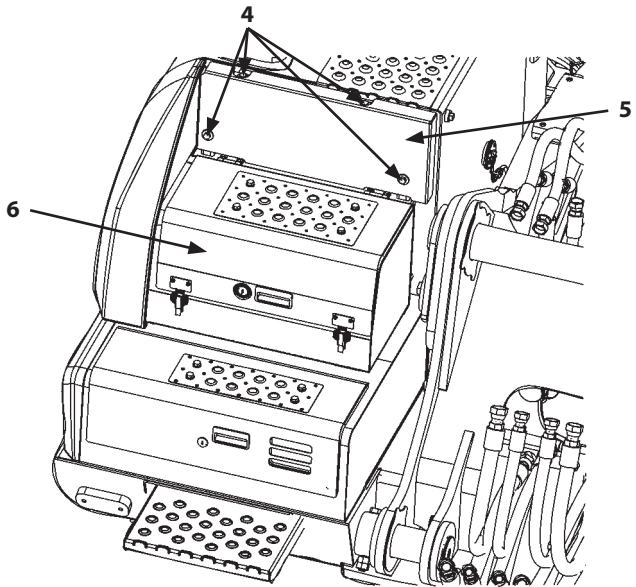

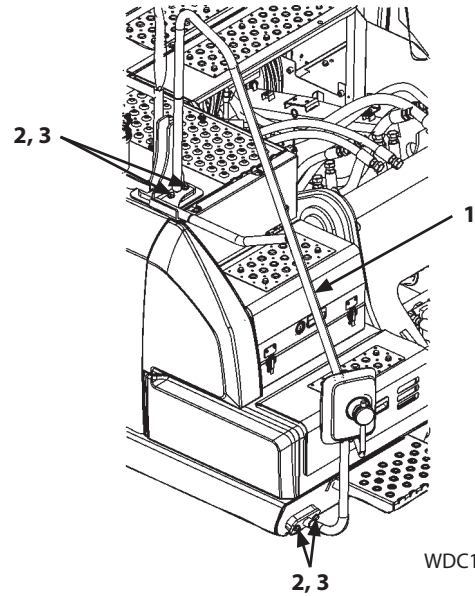

WDC150-03-15-002



WDC150-03-15-001

8. Close cover (6).
9. Install cover (5) with bolts, washers (4) (4 used).

 : 17 mm

 : 50 N·m

10. Install the handrail (1) assembly with washers (3) (4 used) and bolts (2) (4 used).

 : 19 mm

 : 110 N·m

## SECTION 5 FRONT ATTACHMENT

### Group 2 Cylinder

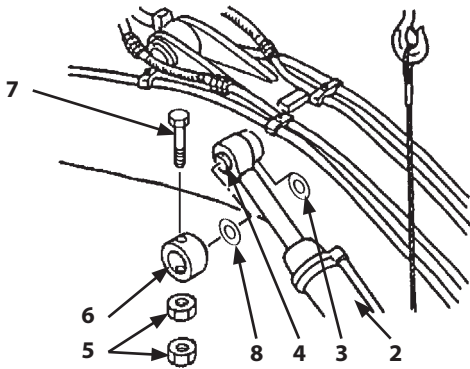

WLBA-05-02-011

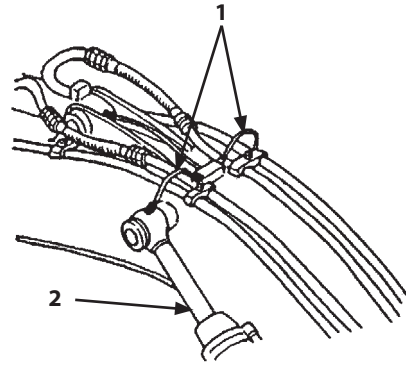

W105-04-02-032

**IMPORTANT:** Check the hydraulic oil level. Start the engine and check for any oil leaks.

9. Remove the wires from one side of the boom cylinder (2) rod side.
10. Start the engine. Operate the boom control lever and fit the hole at cylinder rod side to the mounting holes on the boom.

**CAUTION:** Metal fragments may fly off when a hammer is used. Wear necessary protection, such as goggles, hard hats, etc in order to prevent personal injury.

**IMPORTANT:** Use one or more thrust plates (3, 8) respectively at the right and left sides.

11. Fit thrust plates (3, 8) and pin (4) to the mounting holes on the boom. Install pin (4) by using a hammer.
12. Install bolt (7) to pin (4) and stopper (6) with nuts (5) (2 used).
13. Install other boom cylinder (2) in the same way as step 9 to step 12.

 : 30 mm

 : 280 N·m

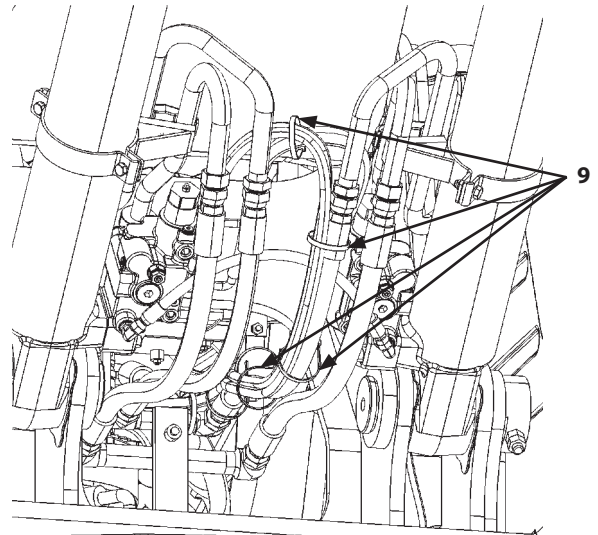

WDC4-05-02-101

14. Install clip bands (9) (4 used).
15. Connect hoses (1) (2 used) to boom cylinders (2). Apply grease.

 : 17 mm

 : 25 N·m

**IMPORTANT:** After completing the work, operate the boom cylinder to the stroke end several times and bleed air from the circuit.

## SECTION 5 FRONT ATTACHMENT

### Group 2 Cylinder

#### Removal and Installation of Bucket Cylinder

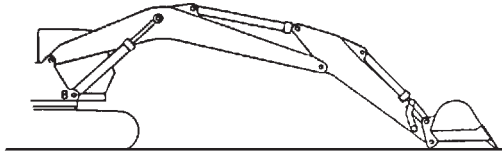

W105-04-02-001

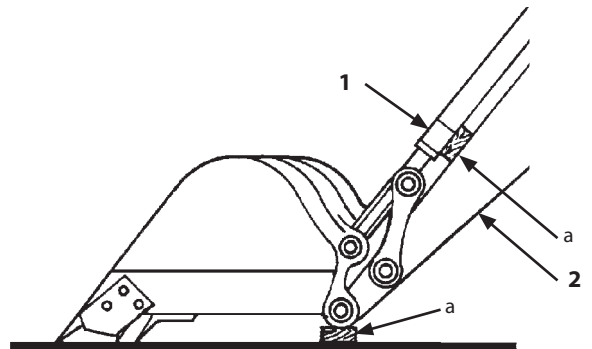

a- Wooden Block

W178-02-11-287

**IMPORTANT:** The hoses and pipes contain hydraulic oil. When removing the hoses and pipes, receive oil with a container in order to avoid spilling oil.

**IMPORTANT:** Cap the open ends in case the hoses and pipes have been disconnected. In addition, attach identification tags onto the connectors, hoses, and pipes for assembling. If the clips which secure the hoses have been removed, install the clips after connecting the hoses.

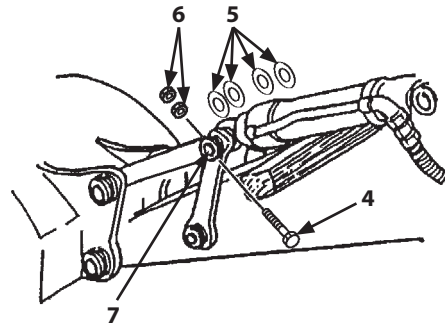

WDBL-05-02-001

#### Removal

1. Park the machine on a solid and level surface. Retract the arm cylinder and bucket cylinder and lower the arm top and bucket teeth onto the ground.
2. Place wooden blocks (a) (2 used) under the arm (2) top and between bucket cylinder (1) and arm (2). Stop the engine.

**CAUTION:** Before removing pin (7), secure the links by using wires in order not to fall off.

**CAUTION:** Metal fragments may fly off when a hammer is used. Wear necessary protection, such as goggles, hard hats, etc in order to prevent personal injury.

3. Remove nuts (6) (2 used) and bolt (4). Remove pin (7) by using a bar and a hammer. Remove thrust plates (5) (4 used).

 : 30 mm

# SECTION 5 FRONT ATTACHMENT

## Group 2 Cylinder

### Assembly of Boom, Arm, and Bucket Cylinders

#### Boom Cylinder

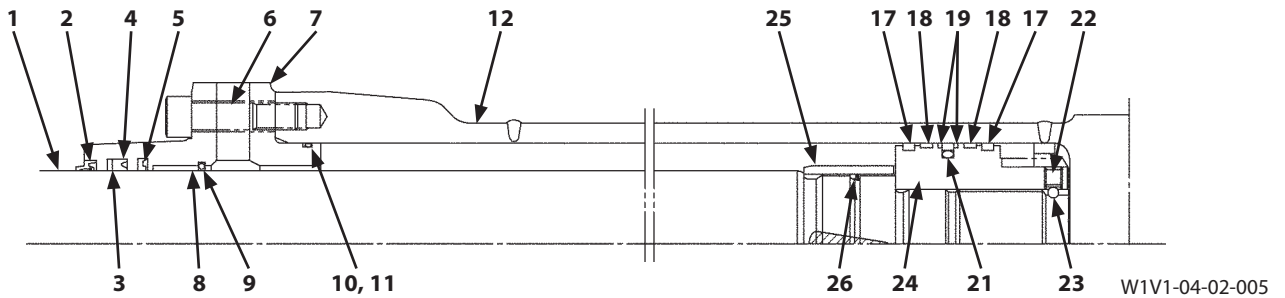

- |                          |                   |                          |                     |
|--------------------------|-------------------|--------------------------|---------------------|
| 1- Cylinder Rod          | 7- Cylinder Head  | 17- Slide Ring (2 Used)  | 24- Piston          |
| 2- Wiper Ring            | 8- Bushing        | 18- Slide Ring (2 Used)  | 25- Cushion Bearing |
| 3- Backup Ring           | 9- Retaining Ring | 19- Backup Ring (2 Used) | 26- Cushion Seal    |
| 4- U-Ring                | 10- Backup Ring   | 21- Seal Ring            |                     |
| 5- Buffer Ring           | 11- O-Ring        | 22- Set Screw            |                     |
| 6- Socket Bolt (12 Used) | 12- Cylinder Tube | 23- Steel Ball           |                     |

## SECTION 6 HYBRID

### Group 1 PCU

#### Removal and Installation of PCU

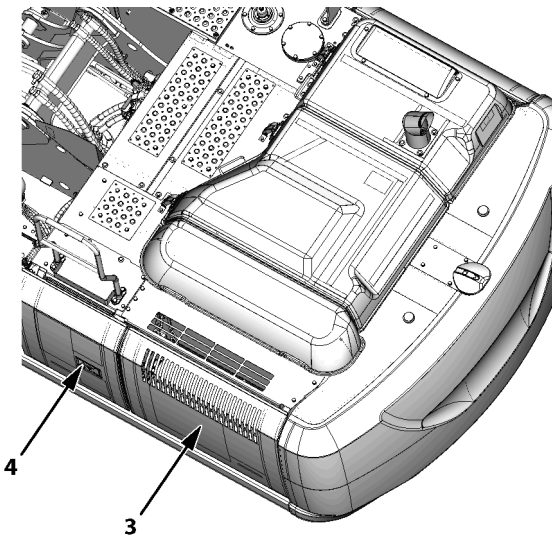

WDFX-06-01-001

**IMPORTANT:** Cap the open ends in case the hoses and pipes have been disconnected. In addition, install identification tags onto the connectors, hoses, and pipes for assembling. If the clips that secure the hoses have been removed, install the clips after connecting the hoses.

#### Removal

1. Set the machine position for inspection and maintenance. (Refer to W1-5-1.)
2. Set the battery disconnect switch to OFF position. (Refer to W1-5-1.)
3. Remove the lithium ion battery disconnect switch. (Refer to W1-6-1.)
4. Open cover (4).
5. Open cover (3).

## SECTION 6 HYBRID

### Group 2 Lithium Ion Battery Unit

---

#### Removal and Installation of Lithium Ion Battery Unit

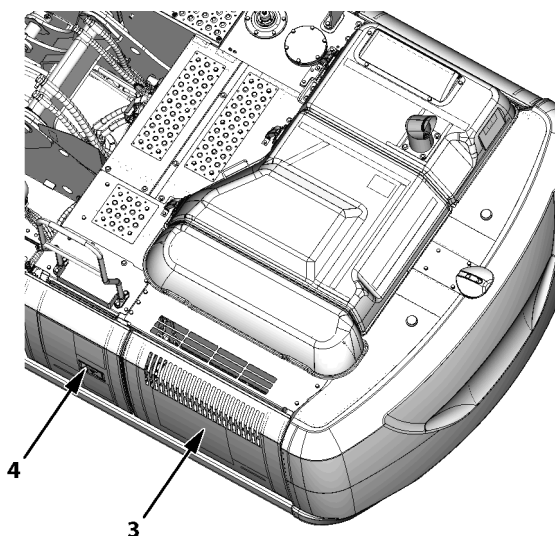

WDFX-06-01-001

**IMPORTANT:** Cap the open ends in case the hoses and pipes have been disconnected. In addition, attach identification tags onto the connectors, hoses, and pipes for assembling. If the clips that secure the hoses have been removed, install the clips after connecting the hoses.

#### Removal

1. Set the machine position for inspection and maintenance. (Refer to W1-5-1.)
2. Set the battery disconnect switch to OFF position. (Refer to W1-5-1.)
3. Remove the lithium ion battery disconnect switch. (Refer to W1-6-1.)
4. Open cover (4).
5. Open cover (3).

## SECTION 6 HYBRID

### Group 3 Solenoid Valve

#### Removal and Installation of Swing Control Solenoid Valve Unit

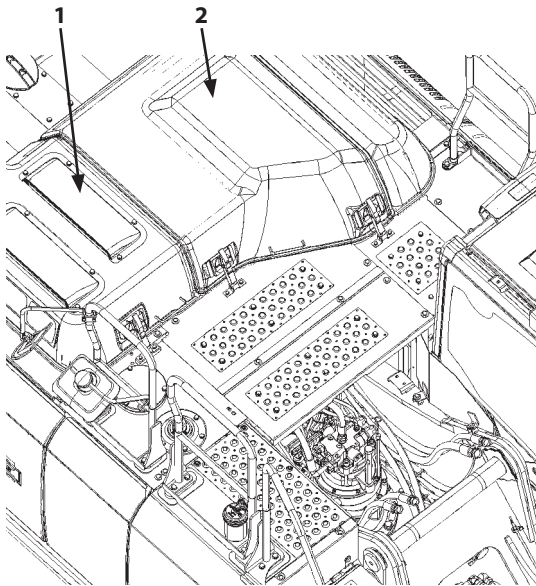

WDC4-03-02-151

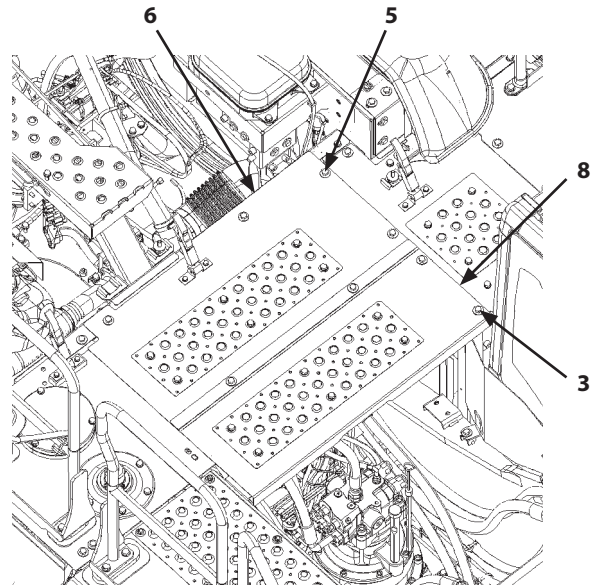

WDC4-03-12-151

**IMPORTANT:** The hoses and pipes contain hydraulic oil. When removing the hoses and pipes, collect the oil in a container in order to avoid spilling oil.

**IMPORTANT:** Cap the open ends in case the hoses and pipes have been disconnected. In addition, attach identification tags onto the connectors, hoses, and pipes for assembling. If the clips that secure the hoses have been removed, install the clips after connecting the hoses.

#### Removal

1. Set the machine position for inspection and maintenance. (Refer to W1-5-1.)

**CAUTION:** Release any pressure from the hydraulic oil tank. (Refer to W1-5-1.)

2. Open engine covers (1, 2).
3. Remove bolts, washers (3) (4 used). Remove cover (8).

 : 17 mm

4. Remove bolts, washers (5) (4 used). Remove cover (6).

 : 17 mm

CLICK HERE TO **DOWNLOAD** THE COMPLETE MANUAL

- Thank you very much for reading the preview of the manual.
- You can download the complete manual from: [www.heydownloads.com](http://www.heydownloads.com) by clicking the link below



- Please note: If there is no response to CLICKING the link, please download this PDF first and then click on it.

CLICK HERE TO **DOWNLOAD** THE COMPLETE MANUAL