

Technical Manual

Troubleshooting

ZAXIS

450-3

450LC-3

470H-3

470LCH-3

500LC-3

520LCH-3

Hydraulic Excavator

Service Manual consists of the following separate Part No;
Technical Manual (Operational Principle) : Vol. No.TO1J1-E
Technical Manual (Troubleshooting) : Vol. No.TT1J1-E
Workshop Manual : Vol. No.W1J1-E

CLICK HERE TO **DOWNLOAD** THE COMPLETE MANUAL

- Thank you very much for reading the preview of the manual.
- You can download the complete manual from: www.heydownloads.com by clicking the link below



- Please note: If there is no response to CLICKING the link, please download this PDF first and then click on it.

CLICK HERE TO **DOWNLOAD** THE COMPLETE MANUAL

SAFETY

ENSURE SAFETY BEFORE RISING FROM OR LEAVING OPERATOR'S SEAT

- Before rising from the operator's seat to open/close either side window or to adjust the seat position, be sure to first lower the front attachment to the ground and then move the pilot control shut-off lever to the LOCK position. Failure to do so may allow the machine to unexpectedly move when a body part unintentionally comes in contact with a control lever, possibly resulting in serious personal injury or death.
- Before leaving the machine, be sure to first lower the front attachment to the ground and then move the pilot control shut-off lever to the LOCK position. Turn the key switch OFF to stop the engine.
- Before leaving the machine, close all windows, doors, and access covers and lock them up.

FASTEN YOUR SEAT BELT

- If the machine should overturn, the operator may become injured and/or thrown from the cab. Additionally the operator may be crushed by the overturning machine, resulting in serious injury or death.
- Prior to operating the machine, thoroughly examine webbing, buckle and attaching hardware. If any item is damaged or worn, replace the seat belt or component before operating the machine.
- Be sure to remain seated with the seat belt securely fastened at all times when the machine is in operation to minimize the chance of injury from an accident.
- We recommend that the seat belt be replaced every three years regardless of its apparent condition.

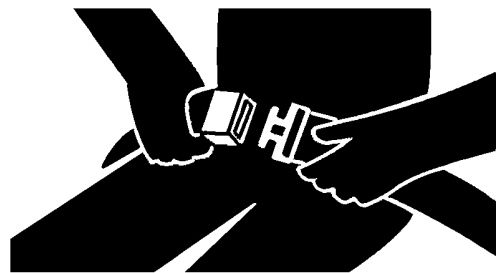

SA-237

010-E01A-0237

SAFETY

AVOID INJURY FROM BACK-OVER AND SWING ACCIDENTS

- If any person is present near the machine when backing or swinging the upperstructure, the machine may hit or run over that person, resulting in serious injury or death.

To avoid back-over and swing accidents:

- Always look around **BEFORE YOU BACK UP AND SWING THE MACHINE**. BE SURE THAT ALL BYSTANDERS ARE CLEAR.
- Keep the travel alarm in working condition (if equipped).
ALWAYS BE ALERT FOR BYSTANDERS MOVING INTO THE WORK AREA. USE THE HORN OR OTHER SIGNAL TO WARN BYSTANDERS BEFORE MOVING MACHINE.
- USE A SIGNAL PERSON WHEN BACKING UP IF YOUR VIEW IS OBSTRUCTED. ALWAYS KEEP THE SIGNAL PERSON IN VIEW.
Use hand signals, which conform to your local regulations, when work conditions require a signal person.
- No machine motions shall be made unless signals are clearly understood by both signalman and operator.
- Learn the meanings of all flags, signs, and markings used on the job and confirm who has the responsibility for signaling.
- Keep windows, mirrors, and lights clean and in good condition.
- Dust, heavy rain, fog, etc., can reduce visibility. As visibility decreases, reduce speed and use proper lighting.
- Read and understand all operating instructions in the operator's manual.

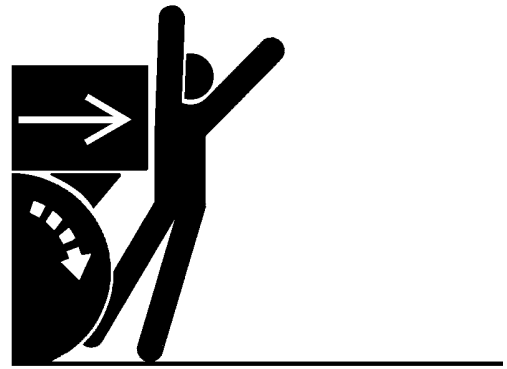

SA-383

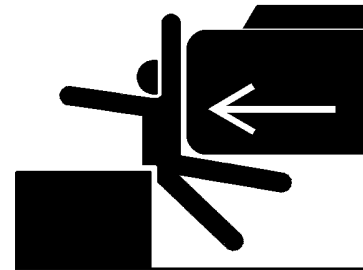

SA-384

021-E01A-0494

SAFETY

PREVENT PARTS FROM FLYING

- Grease in the track adjuster is under high pressure. Failure to follow the precautions below may result in serious injury, blindness, or death.
 - Do not attempt to remove GREASE FITTING or VALVE ASSEMBLY.
 - As pieces may fly off, be sure to keep body and face away from valve.
 - Never attempt to disassemble the track adjuster. Inadvertent disassembling of the track adjuster may cause the parts such as a spring to fly off, possibly resulting in severe personal injury or death.
- Travel reduction gears are under pressure.
 - As pieces may fly off, be sure to keep body and face away from AIR RELEASE PLUG to avoid injury.
 - GEAR OIL is hot. Wait for GEAR OIL to cool, and then gradually loosen AIR RELEASE PLUG to release pressure.



SA-344

503-E01B-0344

STORE ATTACHMENTS SAFELY

- Stored attachments such as buckets, hydraulic hammers, and blades can fall and cause serious injury or death.
 - Securely store attachments and implements to prevent falling. Keep children and bystanders away from storage areas.

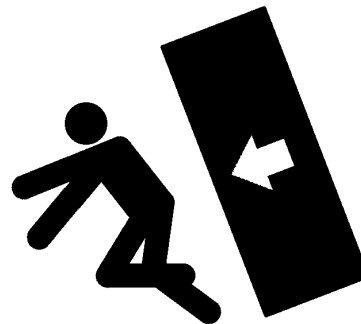

504-E01A-0034

SA-034

SECTION AND GROUP CONTENTS

TECHNICAL MANUAL

(Troubleshooting)

SECTION 4 OPERATIONAL PERFORMANCE TEST

Group 1 Introduction	
Group 2 Standard	
Group 3 Engine Test	
Group 4 Excavator Test	
Group 5 Component Test	
Group 6 Adjustment	

SECTION 5 TROUBLESHOOTING

Group 1 Diagnosing Procedure	
Group 2 Monitor Unit	
Group 3 Dr. ZX	
Group 4 ICF	
Group 5 Component Layout	
Group 6 Troubleshooting A	
Group 7 Troubleshooting B	
Group 8 Electrical System Inspection	

TECHNICAL MANUAL (Operational Principle)

SECTION 1 GENERAL

- Group 1 Specifications
- Group 2 Component Layout
- Group 3 Component Specifications

SECTION 2 SYSTEM

- Group 1 Controller
- Group 2 Control System
- Group 3 ECM System
- Group 4 Hydraulic System
- Group 5 Electrical System

SECTION 3 COMPONENT OPERATION

- Group 1 Pump Device
- Group 2 Swing Device
- Group 3 Control Valve
- Group 4 Pilot Valve
- Group 5 Travel Device
- Group 6 Signal Control Valve
- Group 7 Others (Upperstructure)
- Group 8 Others (Undercarriage)

All information, illustrations and specifications in this manual are based on the latest product information available at the time of publication. The right is reserved to make changes at any time without notice.

OPERATIONAL PERFORMANCE TEST / Standard

MAIN PUMP P-Q DIAGRAM

- Hydraulic P-Q Control

(REFERENCE: Measured at Test Stand)

- Rated Pump Speed: 1750 min⁻¹ (rpm)
- Power Mode Switch: P Mode
- Hydraulic Oil Temperature: 50±5°C

	Delivery Pressure MPa (kgf/cm ² , psi)	Flow Rate L/min (US gpm)
A	20 (205, 2908)	Approx. 250 (66)
B	25 (255, 3635)	Approx. 190 (50)
C	30 (305, 4361)	Approx. 160 (42)

 **NOTE:** Refer to T4-5-14.

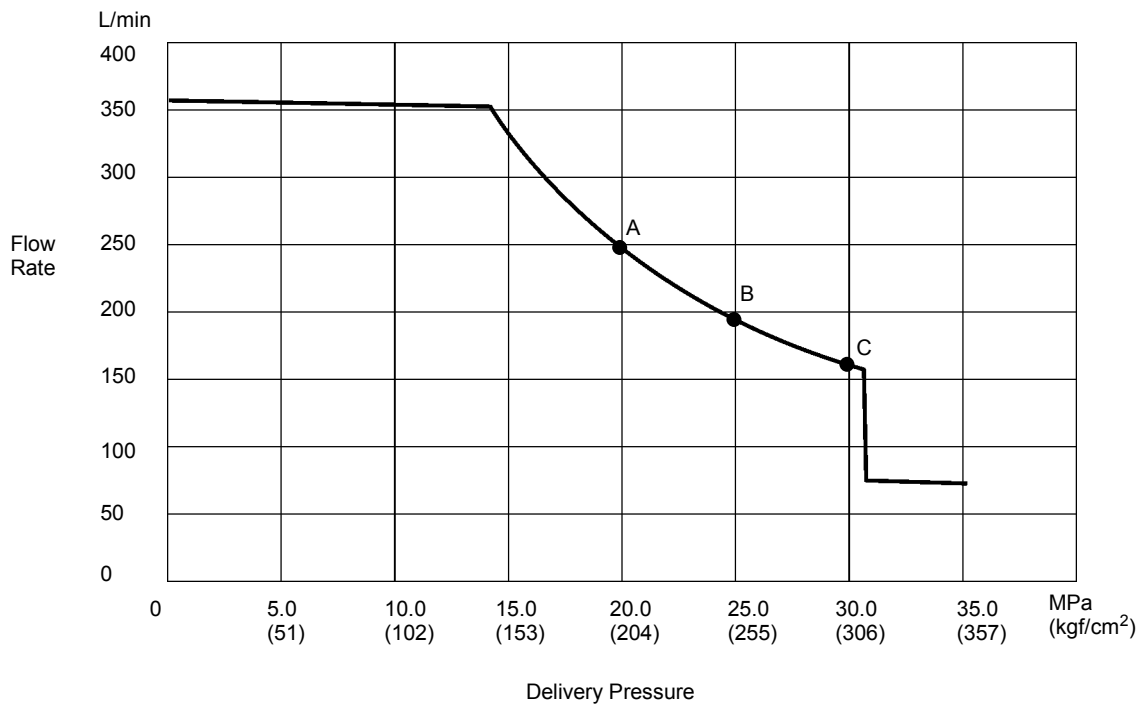

T1J1-04-02-001

OPERATIONAL PERFORMANCE TEST / Standard

SENSOR ACTIVATING RANGE

1. Checking Method

- Hydraulic Oil Temperature: 50±5 °C
- Unless specified:

Engine Control Dial	Power Mode Switch	Work Mode	Auto-Idle Switch
Maximum Speed	P Mode	Digging Mode	OFF

- Monitor each sensor using Dr. ZX.

2. Sensor Activating Range

Sensor	Operation	Specification
Engine Control Dial	Slow Idle Speed	0.3 to 1.0 V
	Fast Idle Speed	4.0 to 4.7 V
Pilot Operation Pressure Sensor	Control Lever: Neutral Pilot Control Shut-Off Lever: LOCK	0 to 0.049 MPa (0 to 0.5 kgf/cm ²)
	Control Lever: Full Stroke Pilot Control Shut-Off Lever: UNLOCK	2.45 to 3.9 MPa (25 to 40 kgf/cm ²)
Pump Regulator Pressure Sensor	Control Lever: Neutral	Pump 1: *0.49 MPa (5.0 kgf/cm ²) Pump 2: *0.44 MPa (4.5 kgf/cm ²)
	Jack-up, Travel Lever: Full Stroke (Jack-up Side)	*1.76 to 2.55 MPa (18 to 26 kgf/cm ²)
Pump Delivery Pressure Sensor (Boom Bottom Pressure Sensor)	Control Lever: Neutral	*0.3 to 0.5 MPa (3 to 5 kgf/cm ²)
	When Boom Raise Relieving	31.9 ⁺¹ ₋₀ MPa (325 ⁺¹⁰ ₋₀ kgf/cm ²)

*: Reference Value

OPERATIONAL PERFORMANCE TEST / Excavator Test

TRAVEL SPEED

Summary:

Measure the time required for the excavator to travel a 20 m (65.6 ft) test track.

Preparation:

1. Adjust the track sag on both side tracks equally.
2. Prepare a flat and solid test track 20 m (65.6 ft) in length with extra length of 3 to 5 m (9.8 to 16 ft) on both ends for machine acceleration and deceleration.

IMPORTANT: The bucket teeth will hit the boom if the bucket is rolled-in with the arm fully rolled-in.

As for this condition: arm fully rolled-in + Bucket fully rolled-in, set the bucket at fully rolled-in and a perform arm roll-in operation.

3. Hold the bucket 0.3 to 0.5 m (12 to 20 in) above the ground with the arm and bucket rolled in.
4. Maintain hydraulic oil temperature at 50 ± 5 °C (122 ± 41 °F).

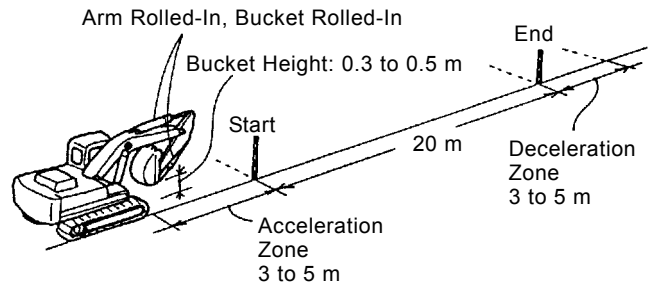

T105-06-03-001

Measurement:

1. Measure both the slow and fast speeds of the machine.
2. Measurement conditions are as below.

Travel Mode Switch	Engine Control Dial	Power Mode Switch	Work Mode	Auto-Idle Switch
Slow Mode	Fast Idle	HP Mode	Digging Mode	OFF
Fast Mode	Fast Idle	HP Mode	Digging Mode	OFF

3. Start traveling the machine in the acceleration zone with the travel levers to full stroke.
4. Measure the time required to travel 20 m (65.6 ft).
5. After measuring the forward travel speed, turn the upperstructure 180° and measure the reverse travel speed.
6. Perform the measurement three times and calculate the average values.

Evaluation:

Refer to the Operational Performance Standard in Group T4-2.

Remedy:

Refer to the Troubleshooting B in Group T5-7.

OPERATIONAL PERFORMANCE TEST / Excavator Test

Measurement:

1. Position the front attachment as follows:

Backhoe:

With the arm cylinders fully retracted and the bucket cylinders fully extended, position the arm tip pin height is flush with the boom foot pin height.

Loading shovel:

With the arm cylinder fully extended and the bucket cylinders fully extended, position the arm top pin height is flush with the boom foot pin height.

2. Lower the bucket to the ground and use it to raise the front idler 0.5 m (20 in). Record the dial gauge reading (h_2).
3. Calculate bearing play (H) from this data (h_1 and h_2) as follows:

$$H=h_2-h_1$$

Evaluation:

Refer to the Operational Performance Standard in Group T4-2.

Backhoe Front

Measurement: (h_1)

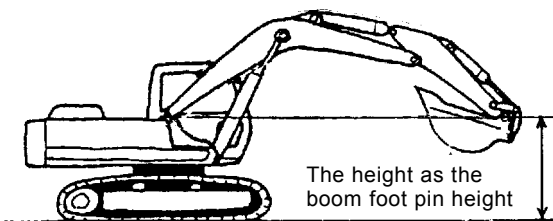

T105-06-03-013

Measurement: (h_2)

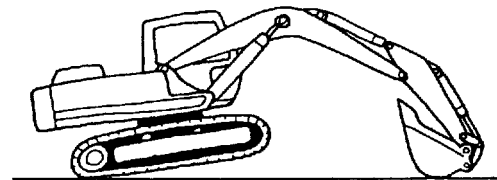

T105-06-03-017

Loading Shovel Front

Measurement: (h_1)

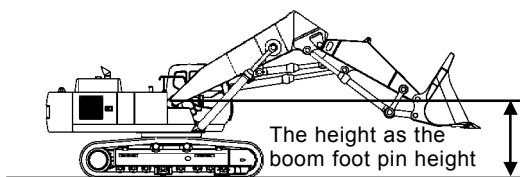

TBAR-04-04-001

Measurement: (h_2)

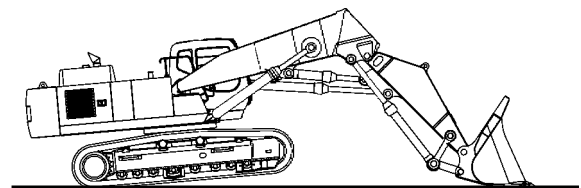

TBAR-04-04-002

OPERATIONAL PERFORMANCE TEST / Component Test

SECONDARY PILOT PRESSURE

Preparation:

1. Stop the engine.
2. Push the air bleed valve on top of the hydraulic oil tank and release any remaining pressure.
3. Measure pressure at the location between pilot valve and signal control valve. Remove the pilot hose from the circuit to be measured. Install the hose (9/16-18UNF, Length: approx. 400 mm (16 in)) to the signal control valve side. Install tee (4351843), adapter (ST 6460), nipple (ST 6069), coupling (ST 6332) and pressure gauge (ST 6315) between the hoses.

 : 17 mm, 19 mm

 **NOTE:** When removing the lines from signal control valve, use tool (SNAP-ON GAN850812B: size 19.05 mm) in order to easily remove the lines.

4. Start the engine. Confirm that no oil leakage is observed at the pressure gauge connection.
5. Maintain the hydraulic oil temperature at 50 ± 5 °C (122 ± 41 °F).

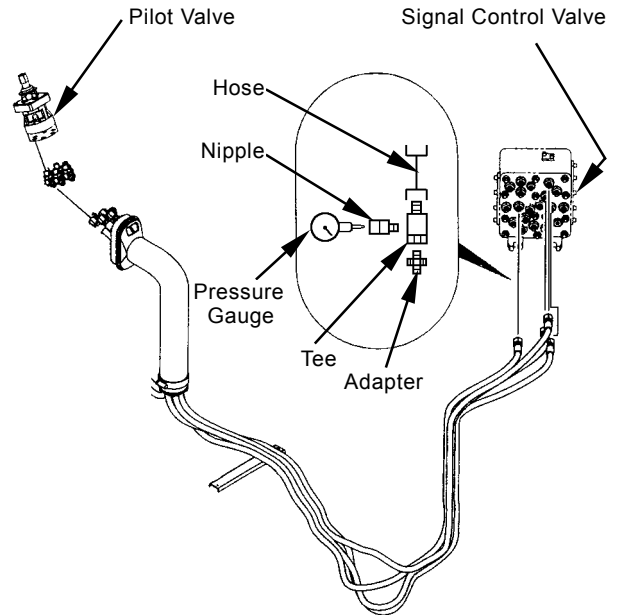

T1F3-04-05-008

Measurement:

1. Measurement conditions are as below.

Engine Control Dial	Power Mode Switch	Auto-Idle Switch	Work Mode
Fast Idle	HP Mode	OFF	Digging Mode
Slow Idle	HP Mode	OFF	Digging Mode

2. Measure pilot pressure by using a pressure gauge with the corresponding control lever operated to full stroke.
3. Repeat the measurement three times and calculate the average values.

Evaluation:

Refer to the Operational Performance Standard in Group T4-2.

Remedy:

Refer to the Troubleshooting B in Group T5-7.

OPERATIONAL PERFORMANCE TEST / Component Test

Measurement:

1. Measurement Conditions are below.

Engine Control Dial	Power Mode Switch	Auto-Idle Switch	Work Mode
Fast Idle	HP Mode	OFF	Digging Mode

2. Slowly operate the bucket, arm and boom control levers to the stroke ends and relieve each function.
3. Read pressures at this time.
4. Perform the measurement for the bucket, arm and boom in that order.
5. Repeat the measurement three times and calculate the average value for each.

Evaluation:

1. Performance of the overload relief valves are normal if the measured main relief pressures are within the specified value range.

Refer to the Operational Performance Standard in Group T4-2.

Overload Relief Valve Pressure Adjustment Procedure

 **NOTE:** In principle, adjust the overload relief valve pressure on a test stand.

Loosen lock nut (1) and adjust pressure by using adjusting screw (2).

1. Loosen lock nut (1).

 : 19 mm

2. Turn adjusting screw (2) in order to adjust pressure.

 : 6 mm

3. Tighten lock nut (1).

 : 19 mm

 : 31.5 N·m (3.2 kgf·m, 23 lbf·ft)

4. Check the set pressure.

 **NOTE:** Standard Change in Pressure (Reference)

Screw Turns	1/4	
Change in Pressure	MPa	5.0
	(kgf/cm ²)	(51)
	(psi)	(725)

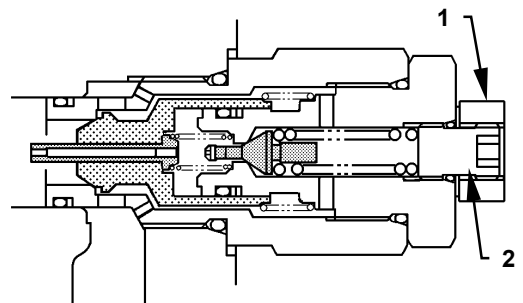

T162-04-04-004

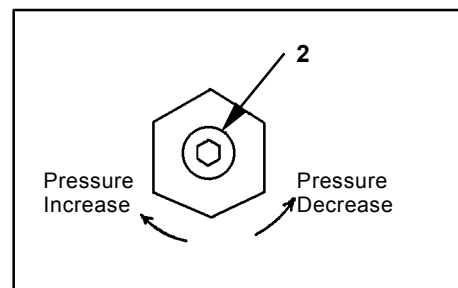

W107-02-05-129

OPERATIONAL PERFORMANCE TEST / Component Test

Measurement:

- Amount of Oil Drained While Swinging the Upperstructure
 1. With the bucket empty, position the front attachment as follows:
 - Backhoe:
With the arm cylinder fully retracted, and the bucket cylinder fully extended, raise the boom so that the arm tip pin height is flush with the boom foot pin height.
 - Loading Shovel:
With the arm cylinder and the bucket cylinder fully extended, raise the boom so that the arm tip pin height is flush with the boom foot pin height.
 2. Start the engine. Operate and hold the swing lever full stroke. Start draining oil measurement after the swing speed reaches a constant maximum speed. The measuring time should be more than 20 seconds.
 3. Repeat the measurement three times in both clockwise and counterclockwise directions, and calculate the average values.

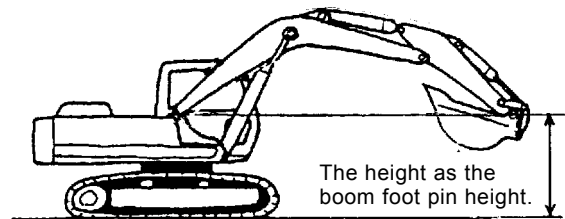

T105-06-03-013

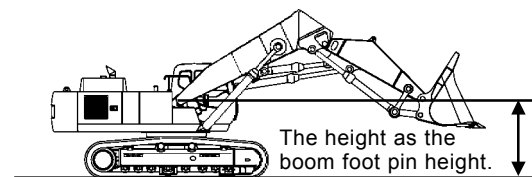

TBAR-04-04-001

- Amount of Oil Drained While Relieving Swing Motor Circuit
 1. Thrust the bucket teeth into the ground as illustrated so that the upperstructure does not rotate when the swing lever is operated full stroke.
 2. Start the engine. Operate and hold the swing lever full stroke. Start drain oil measurement when drain oil starts coming out of the drain hose end. The measuring time should be more than 20 seconds.
 3. Repeat the measurement three times in both clockwise and counterclockwise directions, and calculate the average values.

 **NOTE:** Because the left swing motor drain hose is connected to the right swing motor drain port, the total of the left and right swing motor drainage will be measured when measuring the right swing motor drainage according to step 4 in Preparation. For this reason, be sure to deduct the amount of left swing motor oil drainage (step 3 in Preparation) from that total amount.

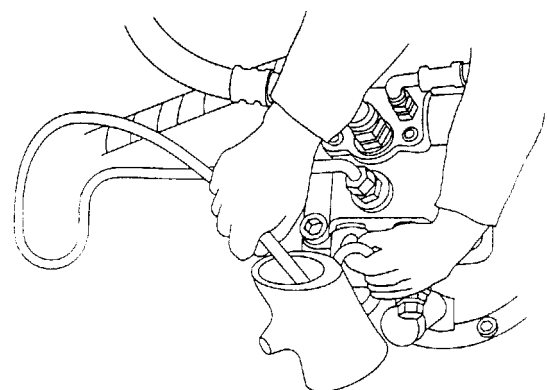

T107-06-05-008

Evaluation:

Refer to the Operational Performance Standard in Group T4-2.

- * Conversion of the amount of drain oil measured into the per-minute value
First measure the amount of drain oil by using a calibrated container. Then, convert the measured drain oil into the per-minute value by using the formula below:

$$\Delta Q = 60 \times q / t$$

Where:

- ΔQ : Amount of drain oil per minute (L/min)
- t : Measured time (seconds)
- q : Total amount of drain oil (L)

OPERATIONAL PERFORMANCE TEST / Adjustment

TORQUE ADJUSTMENT

Adjust pump drive torque, sum of main pumps 1, 2, by using Dr. ZX. (Refer to the T/M (SYSTEM) section.)

**IMPORTANT: These procedures are for only adjustment without repair.
When main pump drive torque need to increase or decrease, do these procedures.**

Adjustment Start Condition:

- MC, ECM: No breakdown and No malfunction (by using Dr. ZX)
- Engine output horsepower: Normal
- Hydraulic oil temperature: 50 ± 5 °C (122 ± 41 °F)

Procedure

1. Connect Palm (Dr. ZX) to the diagnosing connector in the cab by using the Hot Sync cable and connecting harness.
2. Turn the key switch ON or start the engine.
3. When turning Palm ON, the following screen is displayed on the display of Palm.
 - Initial Screen
Select Dr. ZX icon.
 - Password Setup Screen (When the password has unset) Set the password.
 - Service Software Selection Screen
 - Select Large Class ZX-3.
 - Function Selection Screen
 - Self-Diagnostic Result
 - Select Controller
5. Select "Select (Controller)" and operate according to the instruction under display screen.

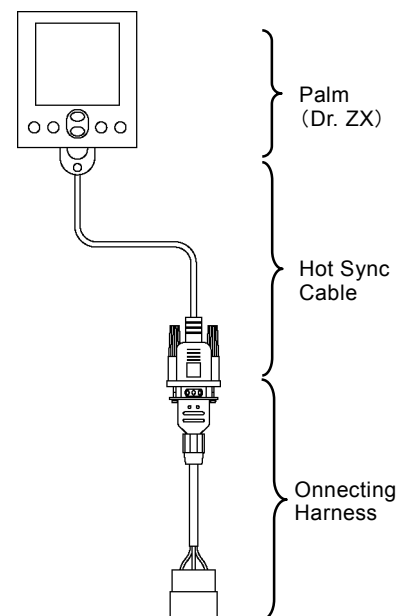
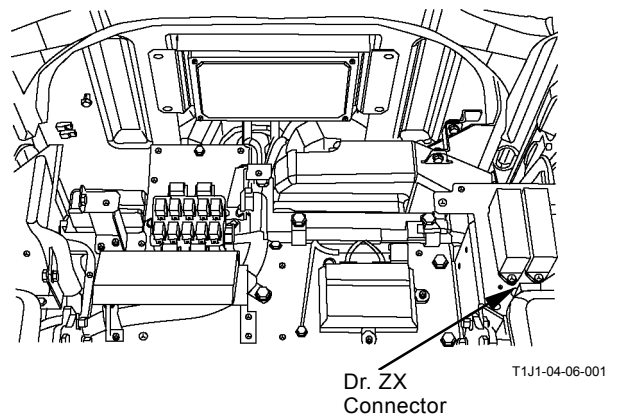

T1V1-05-07-002

TROUBLESHOOTING / Diagnosing Procedure

INTRODUCTION

Refer to the inspection and troubleshooting procedures after any machine trouble has occurred. The inspection and troubleshooting procedures are presented in an orderly fashion in this section to quickly find the cause of the machine trouble and solution.

The troubleshooting section in this manual consists of 8 groups; Diagnosing Procedure, Monitor Unit, Dr. ZX, ICF, Component Layout, Troubleshooting A (base machine diagnosis by using fault codes), Troubleshooting B (base machine diagnosis starting with inspection of abnormal operational status) and Electrical System Inspection.

- Diagnosing Procedure
 - Monitor Unit
Refer to this group as for the display screen and operating procedures of monitor unit.
 - Dr. ZX
This group contains the operating procedures for Dr. ZX.
 - ICF
This group contains as follows.
Download data from ICF and Upload
Procedures when starting satellite communication, when installing the satellite communication controller and when replacing ICF
Explanation for the satellite communication system
 - Component Layout
 - Troubleshooting A (base machine diagnosis by using fault codes)
Refer to these procedures if any fault codes are displayed when each controller (MC, ECM, ICF and monitor unit) is diagnosed by using Dr. ZX (or the service menu of monitor unit).
- IMPORTANT: ICF receives and retains a record of the electrical signal system malfunction of each controller in the form of fault codes by using CAN communication. In addition, ICF self-diagnosing function records the electrical signal system malfunction in the form of fault codes**
- Ex.) Fault Code 11004-2: Failure of CAN Communication
- Troubleshooting B (base machine diagnosis starting with inspection of abnormal operational status)
Refer to these procedures when no fault codes are displayed after diagnosing the machine with Dr. ZX (or the service menu of monitor unit).
Ex.) Although the engine control dial is turned, engine speed does not change.
 - Electrical System Inspection
Refer to this group when required to obtain precautions and/or information for the electrical system inspection.
Ex.) Fuse Check

TROUBLESHOOTING / Monitor Unit

- Troubleshooting

This screen displays fault codes according to the signals received from ICF by using CAN.

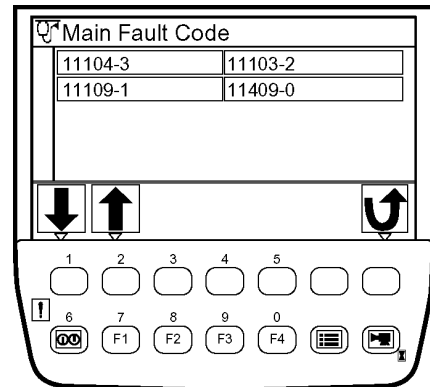

Fault Code Display

T1V5-05-01-097

- Controller Version

This screen displays the version of controller.

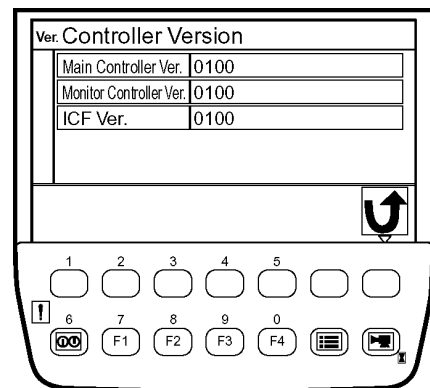

Controller Version Display

T1V5-05-01-122

- Monitoring

This screen displays temperature and pressure data received from each controller by using CAN.

By key operation, the displayed data is hold.

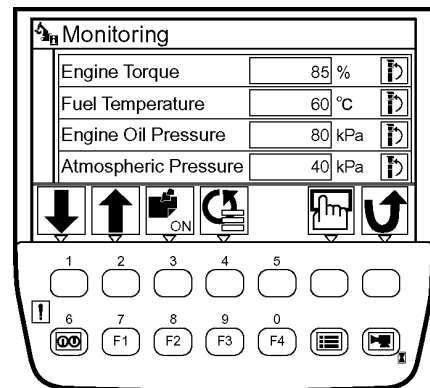

Monitoring Screen

T1V5-05-01-087

- Operating Conditions

This screen displays machine hour, fuel usage and fuel consumption rate registered by the monitor unit.

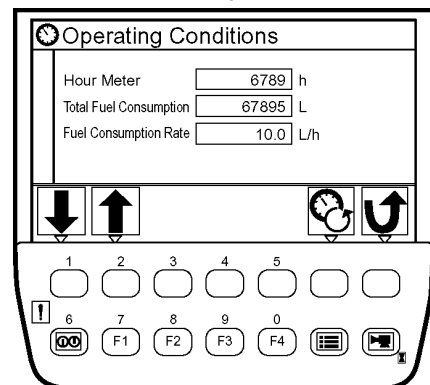

Operating Condition Screen

T1V5-05-01-025

TROUBLESHOOTING / Monitor Unit

Password Change (Optional)

1. After the primary screen is displayed, push the menu key in order to display the main menu.

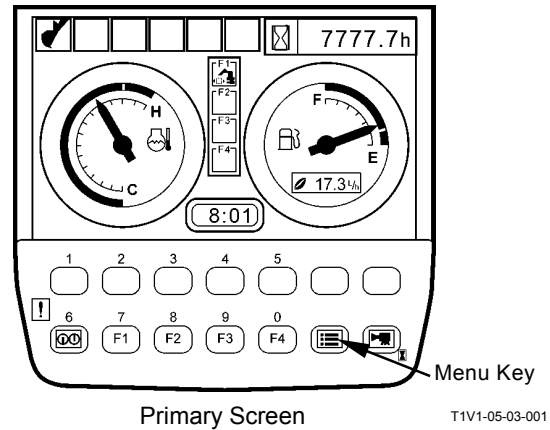

2. Select password change from main menu by using keys 1 and 2. Push the confirm key. Then, the password change screen appears.

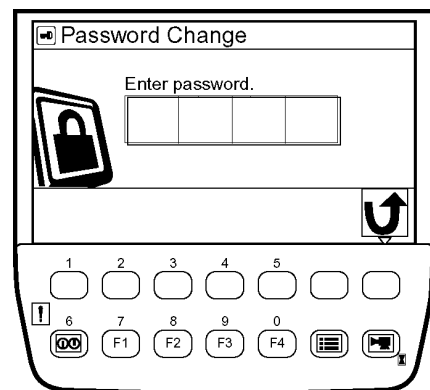
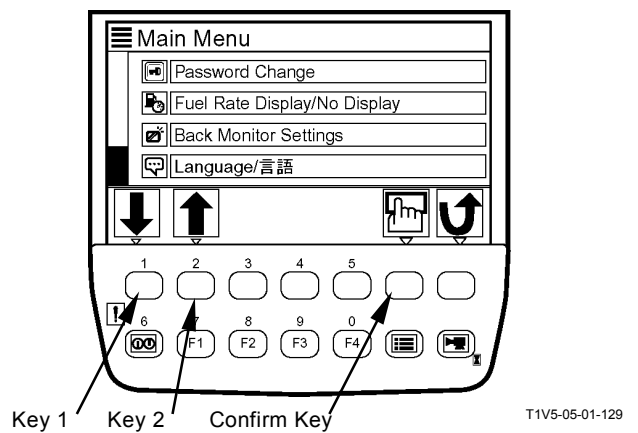

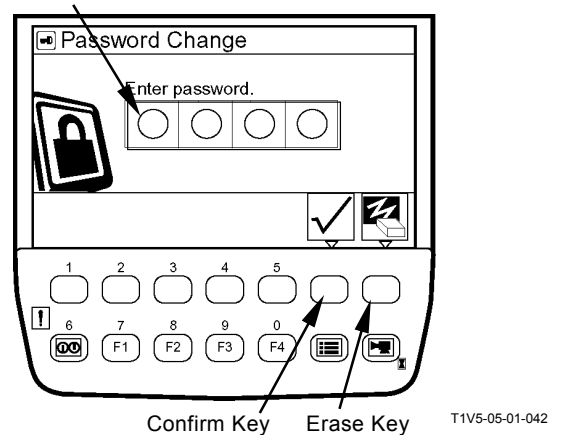

3. Input the registered password and push the confirm key.
4. If inputting the password again, the entered characters can be erased. By pushing the erase key.



TROUBLESHOOTING / Monitor Unit

4. Select controller version by using keys 1 and 2.
Push the confirm key. Then, the controller version screen appears.

 **NOTE:** The version of ECM is not displayed.

 **NOTE:** When pushing the back key, return to the previous screen.

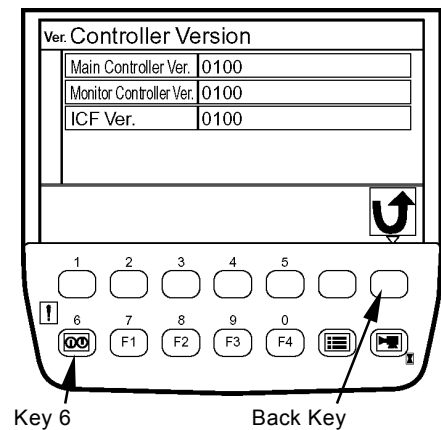
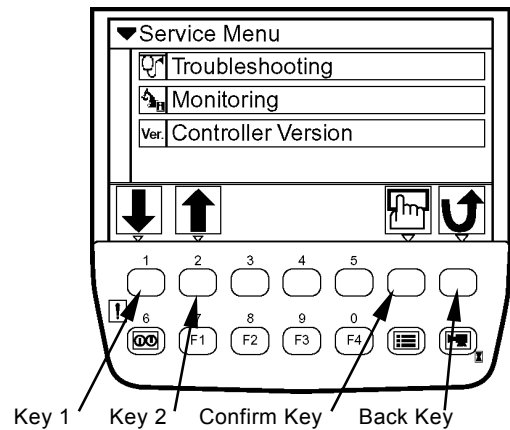

5. Push key 6, and the primary screen appears.

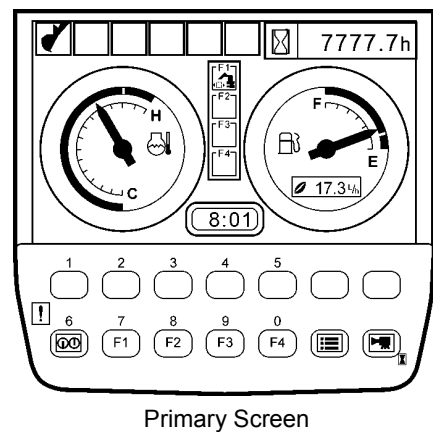

TROUBLESHOOTING / Monitor Unit

TIME SET

1. When the primary screen appears, push the menu key and display main menu.

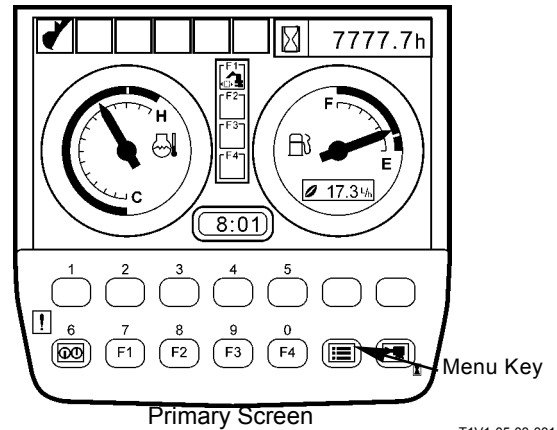

2. Select time set from main menu by using keys 1 and 2. Push the confirm key. Then, the time set screen appears.

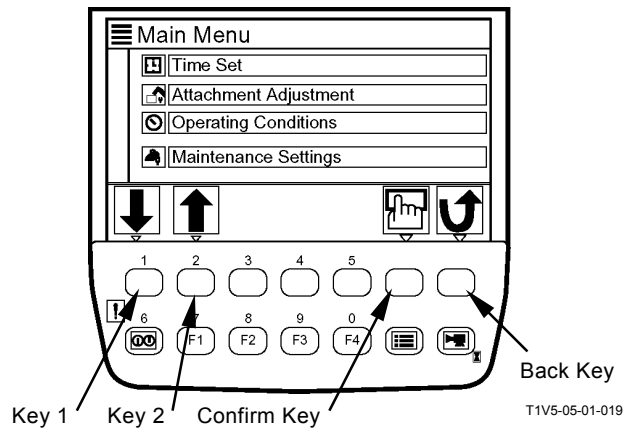

3. On the time set screen, select the items to be set (Year, Month, Day and Time) by using keys 1 and 2, and set the figures by using keys 3 and 4.
4. By using key 2, move the item to . Push the confirm key. Then, system time is updated with the values you specified on the screen.

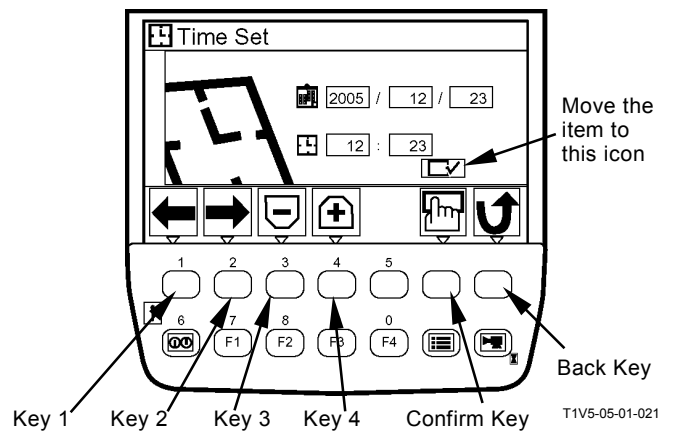

NOTE: When pushing the back key, return to the previous screen.

5. Push key 6, and return to the primary screen.

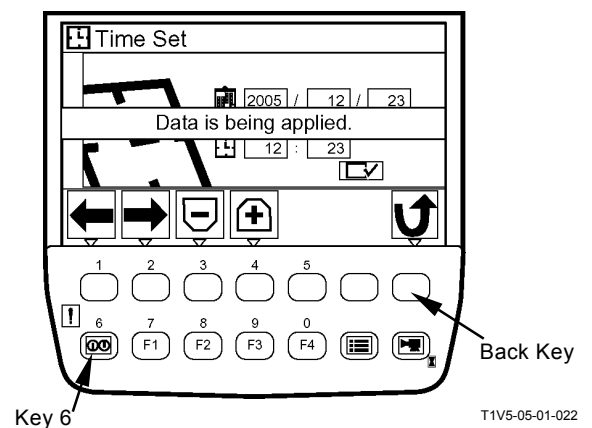

TROUBLESHOOTING / Monitor Unit

4. Push the back monitor switching key, and mirror image is displayed on the screen.

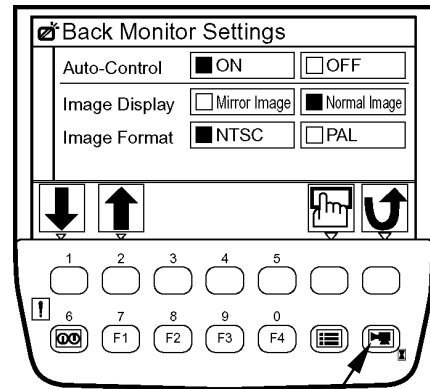

Back Monitor Switching Key

T1V5-05-01-135

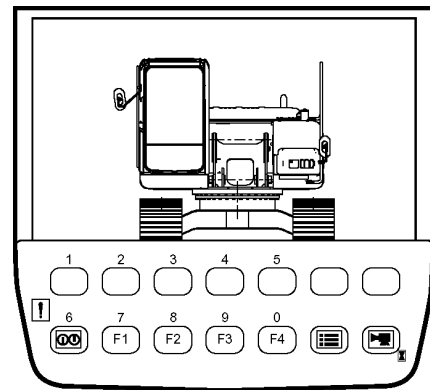

Mirror Image

T1V1-05-01-127

TROUBLESHOOTING / Monitor Unit

 **NOTE:** When ICF could not receive the mail, the message "Mail delivery failed." is displayed on the screen.

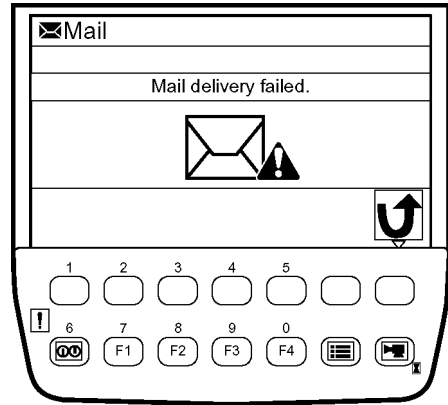

T1V5-05-01-040

TROUBLESHOOTING / Dr. ZX

Item		Unit	Data
Selecting	Monitoring		
Swing Pilot Pressure	SW Pilot Press	MPa	Input signal from pressure sensor (swing)
Left Travel Pilot Pressure	Left TR Press.	MPa	Input signal from pressure sensor (left travel)
Right Travel Pilot Pressure	Right TR Press.	MPa	Input signal from pressure sensor (right travel)
Att. Control Pilot Pressure	Att. Pilot Press.	MPa	Max. pressure when operating boom, arm, bucket, swing, counterweight, aux.1 and/or aux.2
C/W Removal Pilot Pressure	C/W Removal Press.	MPa	Input signal from pressure sensor (counterweight)
Arm Extend (LD) Pilot Pressure	Arm Extend (LD)	MPa	Input signal from pressure sensor (arm roll-out)
Arm Retract (LD) Pilot Pressure	Arm Retract (LD)	MPa	Input signal from pressure sensor (arm roll-in)
Bucket Tilt-Out (LD) Pilot Pressure	Bucket Tilt-Out (LD)	MPa	Input signal from pressure sensor (bucket tilt-out)
Bucket Tilt-Out (LD) Pilot Pressure	Bucket Tilt-In (LD)	MPa	Input signal from pressure sensor (bucket tilt-in)
Auxiliary 2 Pilot Pressure	AUX Pump 2	MPa	Input signal from pressure sensor (aux.2)
Auxiliary 1 Pilot Pressure	AUX Pump 1	MPa	Input signal from pressure sensor (aux.1)
Boom Bottom Pressure	Bm Bottom Press	MPa	Input signal from boom bottom pressure sensor
E/P SW	E/P SW	P, E	Power mode selection status
HP Mode SW	HP Mode SW	OFF, ON	Power mode selection status
Auto-Idle SW	AI SW	AI	Auto idle switch ON/OFF status
Travel Mode SW	Travel 2-Speed Chg Ovr SW	Lo, Hi	Travel mode switch selection status
Power Boost SW	Power Boost SW	OFF, ON	Power digging switch selection status
Key SW	Key SW	OFF, ON	Key switch ON/OFF status
Fan Reverse SW	Fan Dir. SW	OFF, ON	Fan rotation direction ON/OFF status
Test Mode SW	Fan Test Mode SW	OFF, ON	EN test mode switch ON/OFF status
Load Alarm On/Off SW	Load Alarm On/Off SW	OFF, ON	Overload test switch ON/OFF status
Coolant Level SW	Coolant L SW	OFF, ON	Coolant level ON/OFF status
Engine Oil Level SW	Eng Oil L SW	OFF, ON	Engine oil level switch ON/OFF status
Level Check SW	Level Check SW	OFF, ON	Coolant level switch ON/OFF status
Gate Lock SW	Gate Lock SW	OFF, ON	Pilot shut-off switch ON/OFF status
Boom Mode SW	Bm Mode SW	OFF, ON	Boom mode selector switch ON/OFF status
Blower Motor Relay Signal	Blower MOT Sig.	OFF, ON	Blower motor relay ON/OFF status
Pump Regulator Leaning SW	P Reg. Lean. SW	OFF, ON	Pump regulator pressure leaning switch ON/OFF status
Auto Lubrication Counting SW	Lub. Count. SW	OFF, ON	Auto lubrication limiter switch ON/OFF status

TROUBLESHOOTING / Dr. ZX

Item	Unit	Data
ATT5		
ATT5 ATT Type	BR PU CR VI Un Non	Attachment selection
ATT5 ATT Number	1 2 3 4 5	Attachment setting number selection
ATT5 P1 Swash Angle Adjustment	L/min	Adjustment of lower limit of maximum pump 1 flow rate when using attachment
ATT5 P2 Swash Angle Adjustment	L/min	Adjustment of lower limit of maximum pump 2 flow rate when using attachment
ATT5 Engine Speed Adjustment	min ⁻¹	Adjustment of engine speed when using attachment
ATT5 Relief Change (OPT)	ON, OFF	Secondary pilot relief valve ON/OFF selection
ATT5 2nd Relief Change (OPT)	ON, OFF	Selector valve ON/OFF selection
ATT5 Accumulator Change (OPT)	ON, OFF	Accumulator ON/OFF selection
ATT5 2-Speed Change (OPT)	ON, OFF	2-speed selection ON/OFF selection

 **NOTE:** ATT: Attachment
 BR: Hydraulic Breaker
 PU: Secondary Crusher
 CR: Hydraulic Crusher
 VI: Vibrating Hammer
 Un: Other (Special Machine)
 Non: Non Selection

TROUBLESHOOTING / Dr. ZX

Status Selection

Example: ATT Torque Reducing On/Off: Off

Push ATT Torque Reducing On/Off.

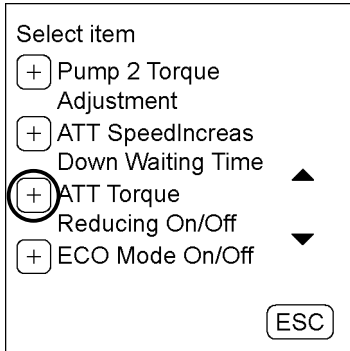

Select item

- Pump 2 Torque Adjustment
- ATT SpeedIncreases Down Waiting Time
- ATT Torque Reducing On/Off
- ECO Mode On/Off

ESC

T1J1-05-03-027

Parameter Change Selection Screen

Push OFF and Push Exec. Push ESC and return to Parameter Change Selection Screen.

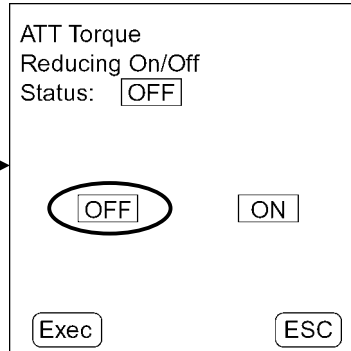

ATT Torque Reducing On/Off

Status: OFF ON

Exec ESC

T1V7-05-03-111

Status Selection Screen

Check OFF and push Exec. Push ESC and return to Parameter Change Selection Screen.

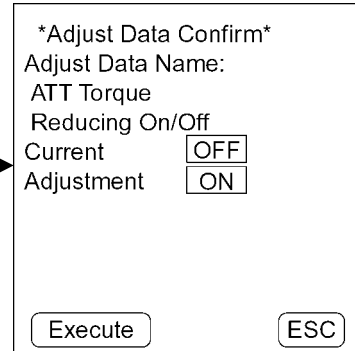

Adjust Data Confirm

Adjust Data Name: ATT Torque Reducing On/Off

Current OFF ON

Adjustment OFF ON

Execute ESC

T1V7-05-03-112

To the lower

Push ESC and return to Parameter Change Selection Screen.

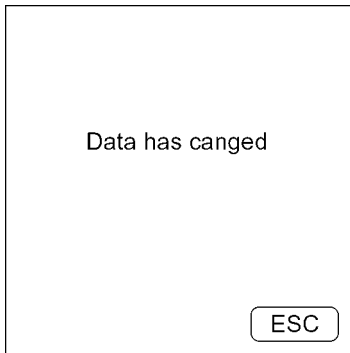

Data has canged

ESC

T1V7-05-03-107

TROUBLESHOOTING / Dr. ZX

Input the password and push OK.
Push Cancel and return to Main Menu Screen.

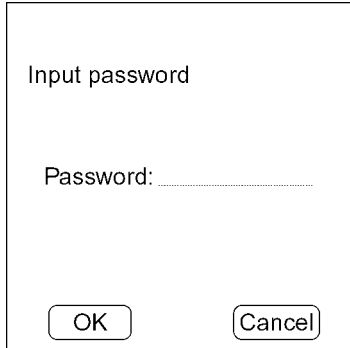

T1V7-05-03-022

Setup Password Input Screen

Push Parameter Change.
Push ESC and return to Main Menu Screen.

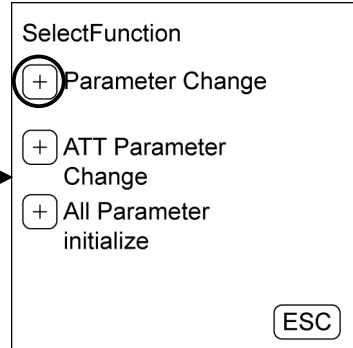

T1J1-05-03-021

Setup Item Selection Screen

Push OK.
Push ESC and return to Main Menu Screen.

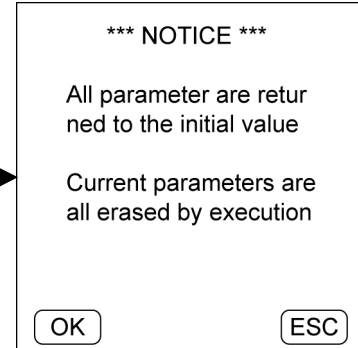

T1J1-05-03-005

Explanation Screen

Push OK and execute All Parameter initialize. Push Abort and stop All Parameter initialize.

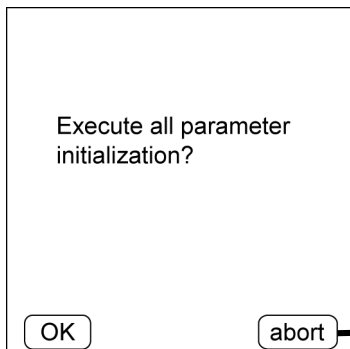

T1J1-05-03-006

Execution Screen

Push ESC and return to Main Menu Screen.

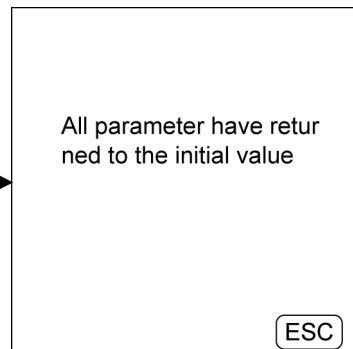

T1J1-05-03-007

All parameter have returned to the initial value

Push ESC and return to Main Menu Screen.

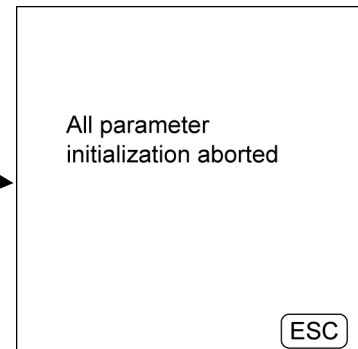

T1J1-05-03-008

All parameter initialization aborted

IMPORTANT: After all parameter initialize operation is completed, turn the key switch OFF over 3 seconds.

IMPORTANT: If All Parameter Initialize is executed, pump learning value is erased. After All Parameter Initialize is executed, perform the pump learning. (Refer to the Adjustment group / OPERATIONAL PERFORMANCE TEST.)

TROUBLESHOOTING / Dr. ZX

MAIN MENU INFORMATION C/U VARIOUS SETUP

List of Controller Data Setting Item

Item		Range of Data	
Information C/U: Initialize		Initialize/ESC	
Enter Model and Serial No.	Model	ASCII (4 characters) 0 to 9, A to Z	
	Serial No.	000000 to 999999	
Enter Date and Time	Date	YY	2000 to 2100
		MM	1 to 12
		DD	1 to 31
	Time	HH	0 to 23
		MM	0 to 59
Control Data: Initialize		Initialize/ESC	
Satellite Terminal: Initialize		DEL/ESC	
Satellite Terminal No. Confirmation		12 digits: 0 to 9, A to Z	
Communicating State Check	ICF < = > Satellite Terminal	Connect	Conn/UnConn
		Comm.	OK/NG
	Satellite Terminal	Power	ON/OFF
		Comm.	Enable/Stop
	Rod Aerial		OK/NG
	GPS Aerial		OK/NG
	Wave State		ON/OFF
	Un-Transmit Data Number		0~99
	Last Transmitting Time		YYYY/MM/DD hh: mm: ss
Enter Satellite Comm. Start/Stop		Start/Stop	

TROUBLESHOOTING / Dr. ZX

DATA DOWNLOAD

After starting Dr. ZX, push Select Controller.

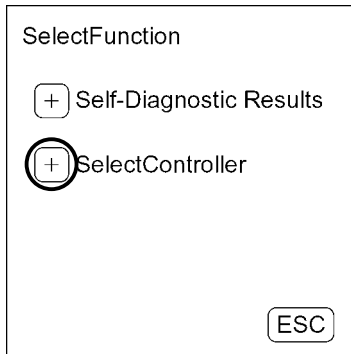

Function Selection Screen

T1V7-05-03-001

Push Information C/U.

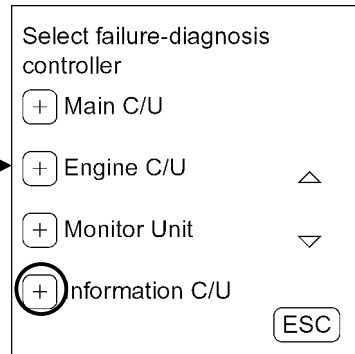

Controller Selection Screen

T1V7-05-03-009

Push OK.

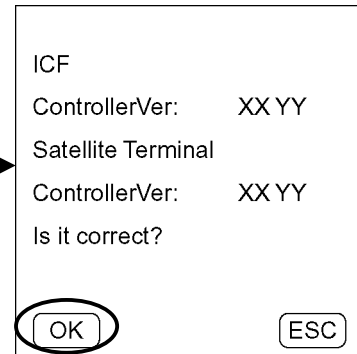

ICF Controller Screen

T1J1-05-03-045

To the lower

Push Start.



Title Screen

T1V7-05-03-025

Push Data Download.

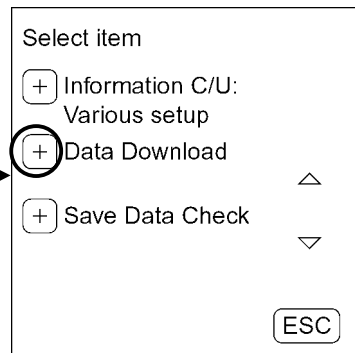

Main Menu Screen

T1V7-05-03-026

While downloading data, Download Screen is displayed.

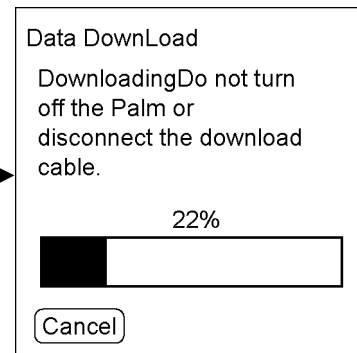

Data Download Screen

T1V7-05-03-038

To the lower

When downloading is completed normally, Normal End Screen is displayed. Push OK and return to Main Menu Screen.

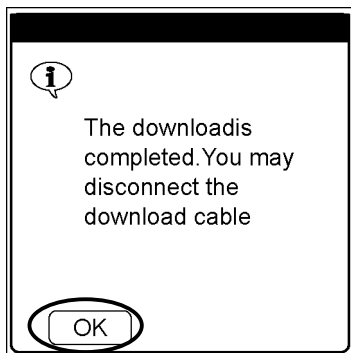

Normal End Screen

T1V7-05-03-039

If pushing Cancel on Data Download Screen, Alarm Screen is displayed. Push OK and return to Main Menu Screen.

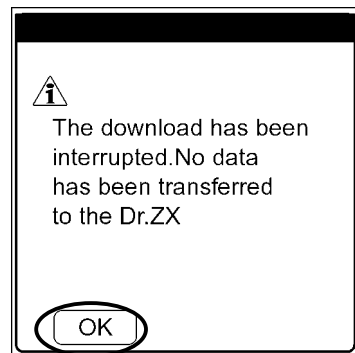

Alarm Screen

T1V7-05-03-148

Push ESC and return to Title Screen.

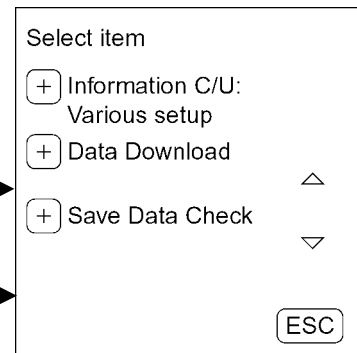

Main Menu Screen

T1V7-05-03-026

TROUBLESHOOTING / Dr. ZX

Move the item by using ▼ and push Menu 7.

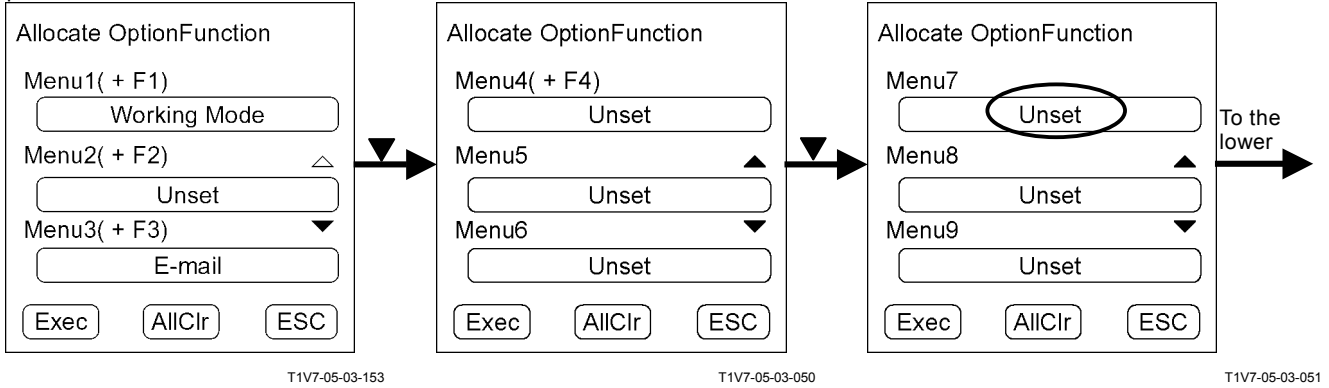

Push ML Crane.

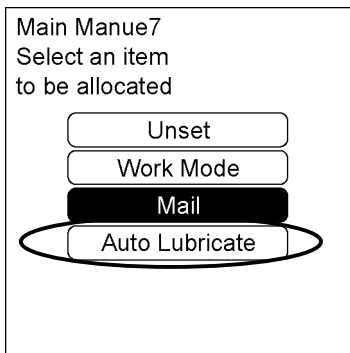

T1J1-05-03-047

Push Exec.

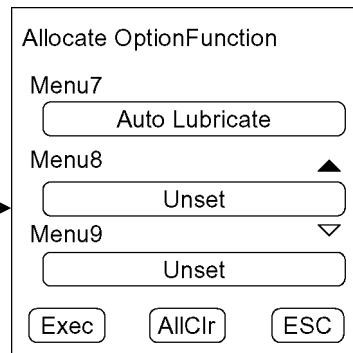

T1J1-05-03-048

Option Function Allocate Screen

Option Function Allocate Execution Screen is displayed. Push ESC and return to Various Setup Item Screen.

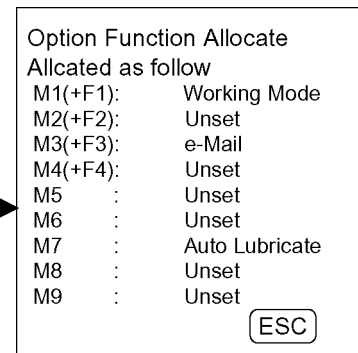

T1J1-05-03-049

Option Function Allocate Execution Screen

Function that can be selected: Unset

Work Mode
Auto Lubrication
Mail

If the functions that can be selected are too much to be settled in one page, the next page can be displayed by using a page change button.

IMPORTANT: The function that has already been allocated cannot be selected.

TROUBLESHOOTING / Dr. ZX

Back Monitor Function: Disable

After starting Dr. ZX, push Select Controller.

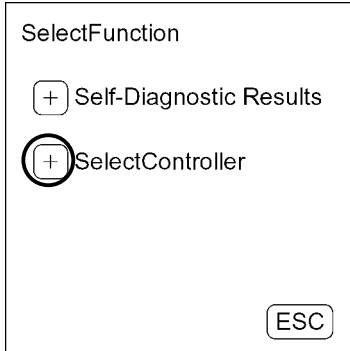

T1V7-05-03-001

Function Selection Screen

Push Monitor Unit.

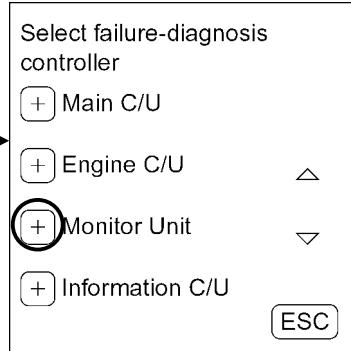

T1V7-05-03-009

Controller Selection Screen

Push OK.

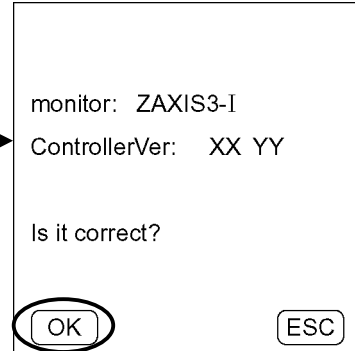

T1J1-05-03-046

Monitor Controller Screen

To the lower

Push Start.



T1V7-05-03-025

Title Screen

Push Various setting.

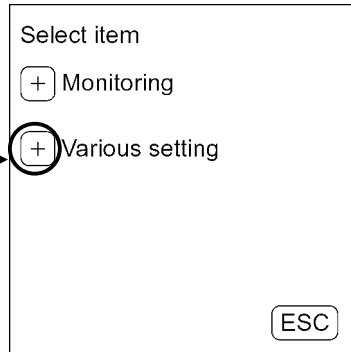

T1V7-05-03-042

Main Menu Screen

Push Back Monitor Setup.

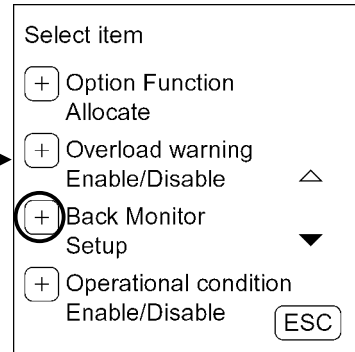

T1V7-05-03-046

Various Setup Item Screen

To the lower

Push Back Monitor Function Enable / Disable. Push ESC and return to the former screen.

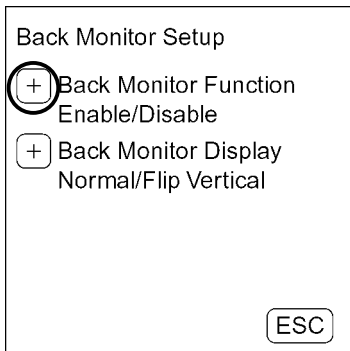

T1V7-05-03-052

Push Enable and push Exec. Push ESC and return to Various Setup Item Screen.

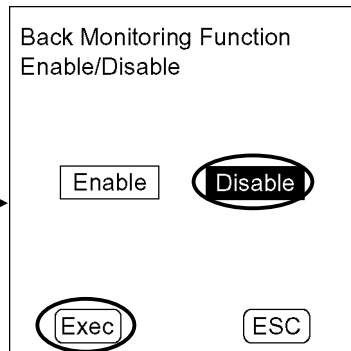

T1J1-05-03-055

NOTE: Push Disable, push ESC and return to Various Setup Item Screen, so that Back Monitor Function Disable is not set.

Push ESC and return to Various Setup Item Screen.

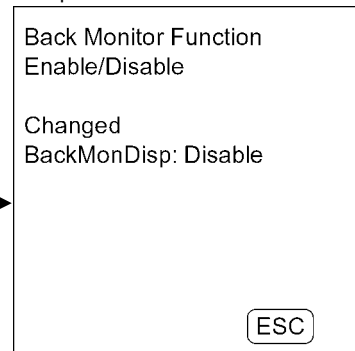

T1V7-05-03-057

TROUBLESHOOTING / Dr. ZX

Notification Function: Disable

After starting Dr. ZX, push Select Controller.

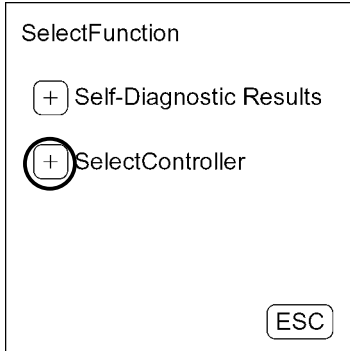

T1V7-05-03-001

Function Selection Screen

Push Monitor Unit.

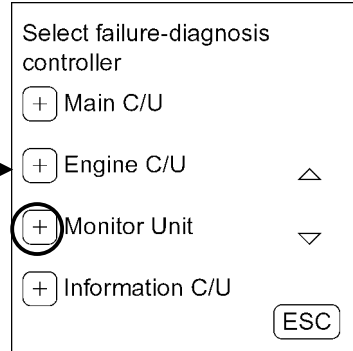

T1V7-05-03-009

Controller Selection Screen

Push OK.

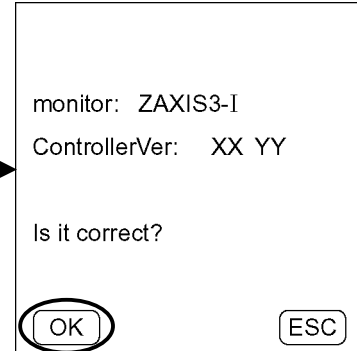

T1J1-05-03-046

Monitor Controller Screen

To the lower

Push Start.



T1V7-05-03-025

Title Screen

Push Various setting.

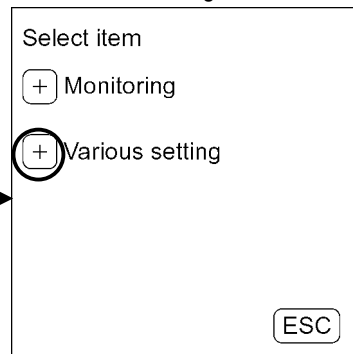

T1V7-05-03-042

Main Menu Screen

Move the item by using ▼ and push Maintenance Setup.

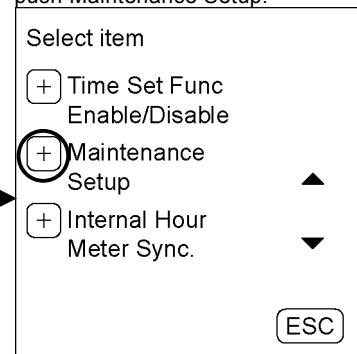

T1V7-05-03-063

Various Setup Item Screen

To the lower

Push Notification function Enable/Disable.

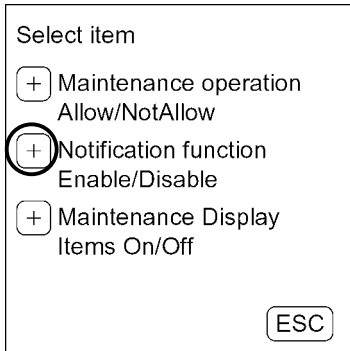

T1V7-05-03-069

Maintenance Set Item Screen

Push Disable and push Exec. Push ESC and return to the former screen.

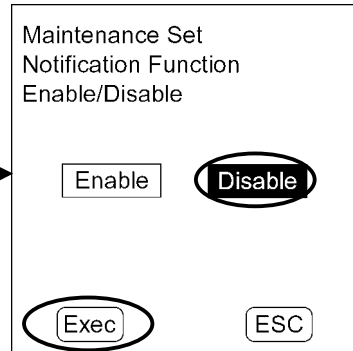

T1V7-05-03-076

NOTE: Push Disable, push ESC and return to Maintenance Set Item Screen, so that Notification Function Disable is not set.

Push ESC and return to Various Maintenance set Item Screen.

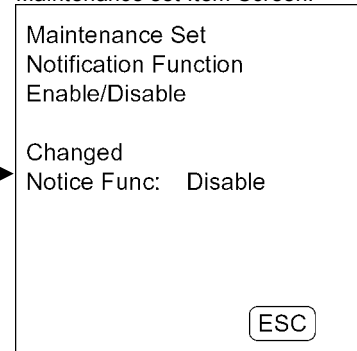

T1V7-05-03-077

CLICK HERE TO **DOWNLOAD** THE COMPLETE MANUAL

- Thank you very much for reading the preview of the manual.
- You can download the complete manual from: www.heydownloads.com by clicking the link below



- Please note: If there is no response to CLICKING the link, please download this PDF first and then click on it.

CLICK HERE TO **DOWNLOAD** THE COMPLETE MANUAL

TROUBLESHOOTING / ICF

OUTLINE

ICF (Information Controller) saves the input signals from various sensors and switches of the machine as data.

Various input signals are recorded as “list of daily report data”, “list of frequency distribution data”, “list of total operating hours”, “list of alarm” and “list of failure” in ICF.

The recorded data is downloaded to the personal computer and is uploaded to the center server via LAN, so that the data can be used as “e-Service”.

The machine equipped with the satellite communication terminal (optional) sends the data to center server by using satellite communication. (As for the satellite communication system, refer to T5-4-24.

TROUBLESHOOTING / ICF

VARIOUS SETUP OF ICF AND SATELLITE COMMUNICATION TERMINAL BY USING Dr. ZX

Before starting satellite communication, installing the satellite communication terminal and replacing ICF, perform the following procedures by using Dr. ZX.

ICF Setup Procedures

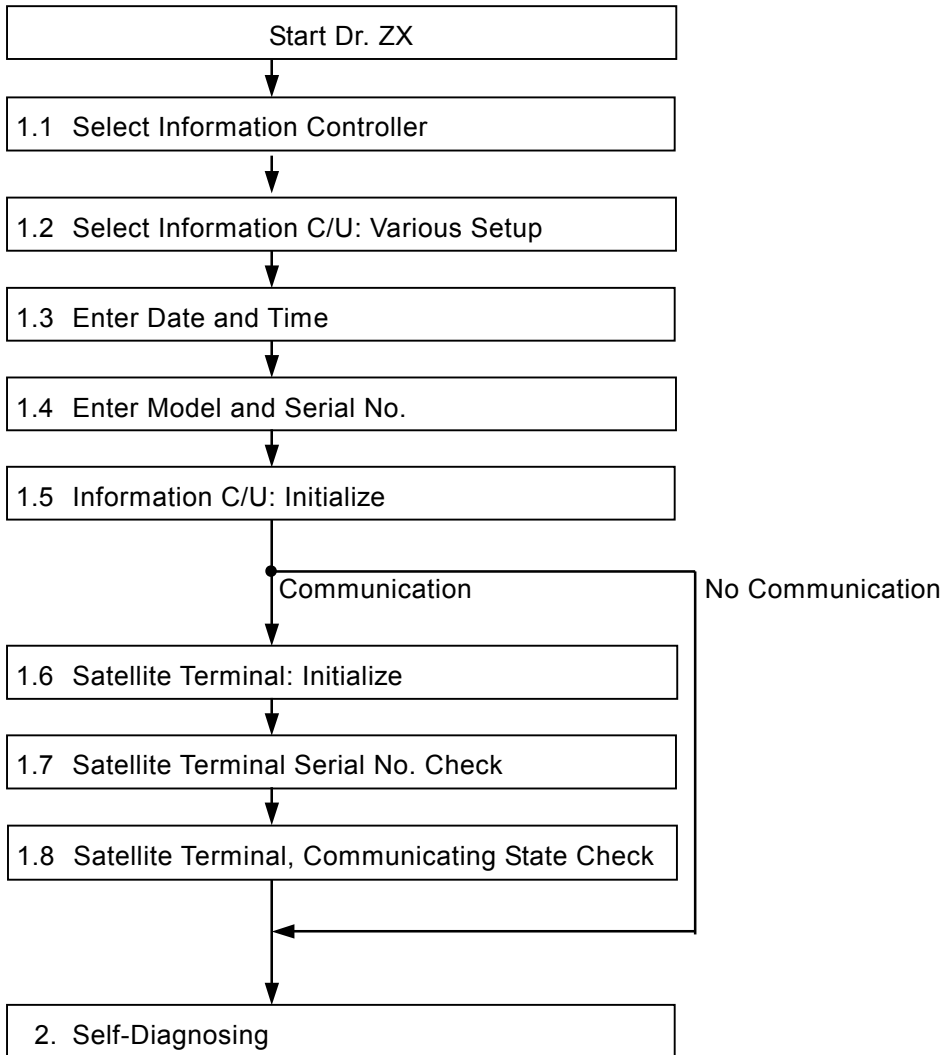

TROUBLESHOOTING / ICF

(Blank)

TROUBLESHOOTING / Component Layout

Electrical Component Layout (Rear Tray)

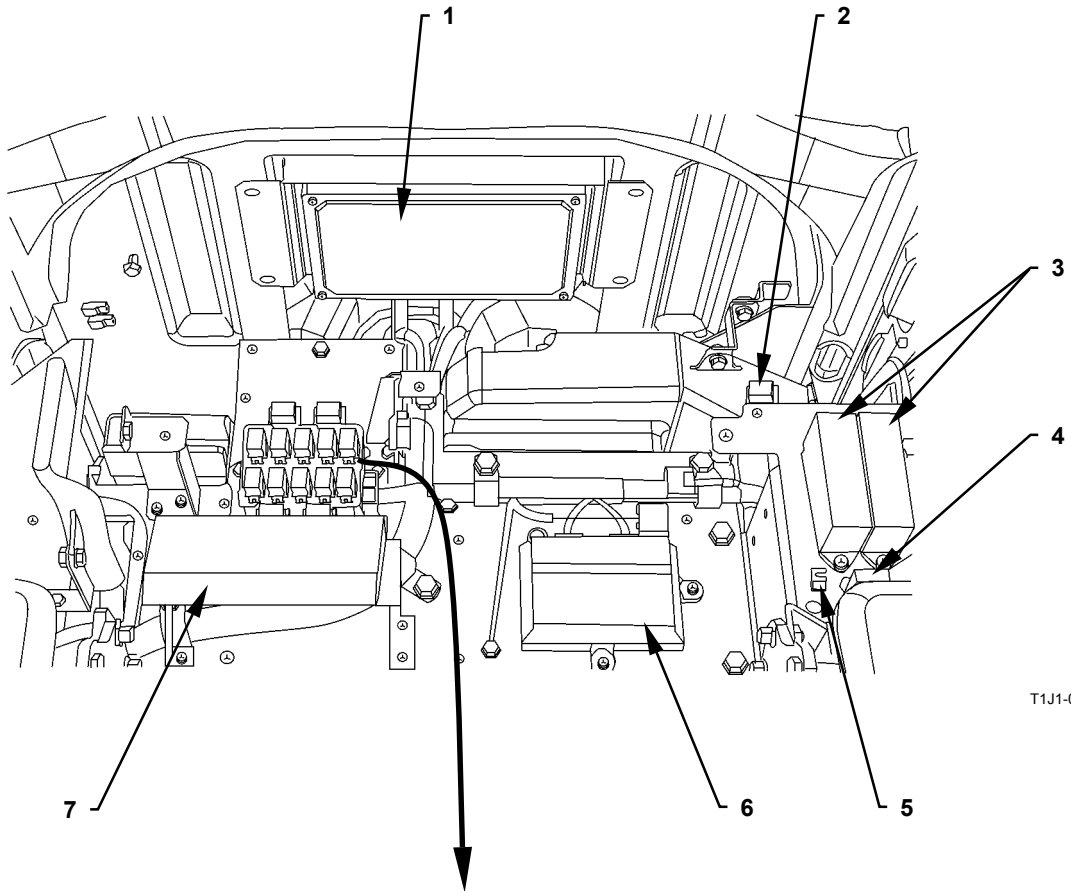

T1J1-01-02-003

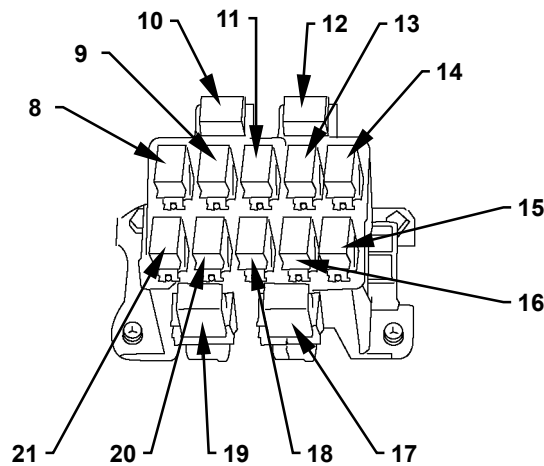

T1V1-01-02-009

- | | | | |
|--|---|--|-------------------------------------|
| 1 - MC (Main Controller) | 7 - Satellite Communication Terminal (Optional) | 12 - Auto-Lubrication Relay (R11) (Optional) | 17 - Light Relay 3 (R13) (Optional) |
| 2 - Overload Alarm Relay (Optional) | 8 - Security Relay (R5) | 13 - Lock Relay (R2) | 18 - Light Relay 2 (R8) |
| 3 - Fuse Box | 9 - Starter Cut Relay (R4) | 14 - Load Damp Relay (R1) | 19 - ECM Main Relay (R14) |
| 4 - Dr. ZX Connector (Use as Download Connector) | 10 - Hour Meter Relay (R12) (Optional) | 15 - Wiper Relay (R6) | 20 - Washer Relay (R9) |
| 5 - Pump Learning Switch | 11 - Security Horn Relay (R3) | 16 - Light Relay 1 (R7) | 21 - Horn Relay (R10) |
| 6 - ICF (Information Controller) | | | |

TROUBLESHOOTING / Component Layout

Cross Section C-C

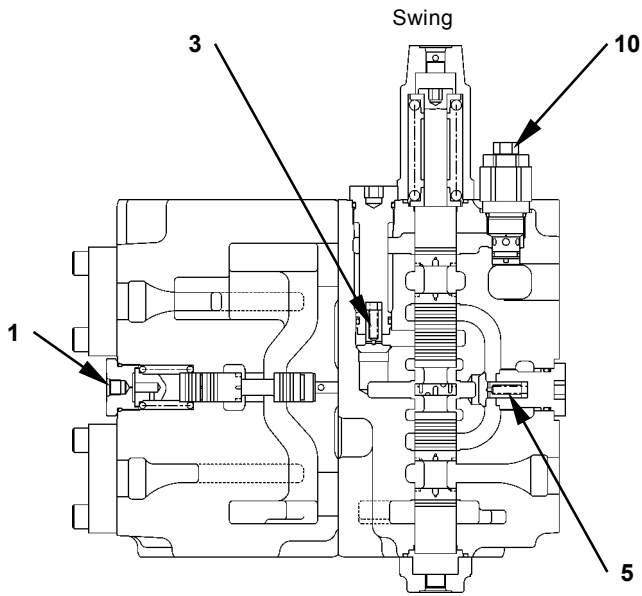

T450-03-03-016

Cross Section D-D

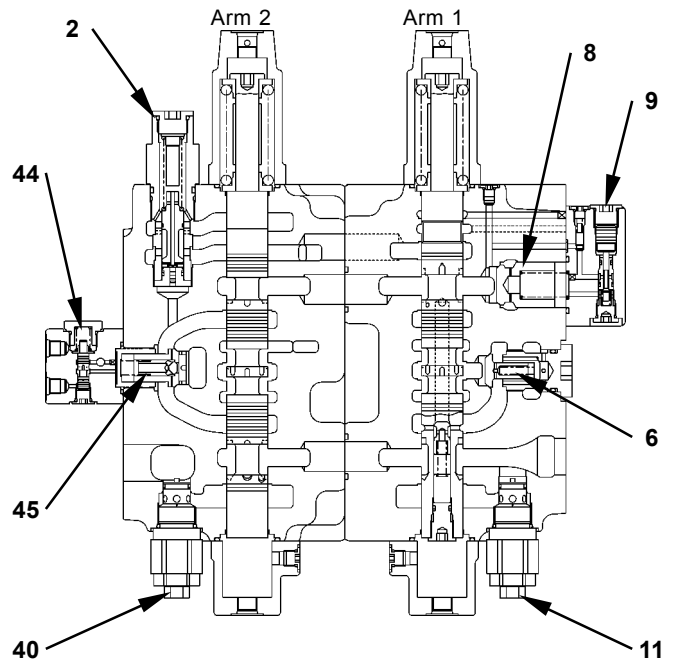

T450-03-03-023

- | | | | |
|--|---|--|--|
| <p>1 - Bypass Shut-Out Valve</p> <p>2 - Arm Regenerative Valve (Switch Valve)</p> <p>3 - Check Valve (Arm 1 Roll-Out Parallel Circuit)</p> <p>4 - Load Check Valve (Arm 1 Roll-In Parallel Circuit)</p> <p>5 - Load Check Valve (Swing Tandem Circuit)</p> <p>6 - Load Check Valve (Arm 1 Tandem Circuit)</p> <p>7 - Arm Regenerative Valve (Check Valve)</p> <p>8 - Arm Anti-Drift Valve (Check Valve)</p> <p>9 - Arm Anti-Drift Valve (Switch Valve)</p> <p>10 - Overload Relief Valve (Arm Roll-Out)</p> <p>11 - Overload Relief Valve (Arm Roll-In)</p> <p>12 - Load Check Valve (Boom 2 Tandem Circuit)</p> | <p>13 - Load Check Valve (Boom 2 Parallel Circuit)</p> <p>14 - Boom Regenerative Valve</p> <p>15 - Overload Relief Valve (Boom Mode)</p> <p>16 - Boom Overload Relief Control Valve</p> <p>17 - Load Check Valve (Auxiliary Tandem Circuit)</p> <p>18 - Overload Relief Valve (Auxiliary)</p> <p>19 - Overload Relief Valve (Auxiliary)</p> <p>20 - Load Check Valve (Auxiliary Parallel Circuit)</p> <p>21 - Load Check Valve (Left Travel Tandem Circuit)</p> <p>22 - Bypass Shut-Out Valve</p> <p>23 - Load Check Valve (Left Travel Parallel Circuit)</p> | <p>24 - Check Valve (Main Relief Pressure Flow combining Circuit)</p> <p>25 - Check Valve (Bucket Flow Combining Circuit)</p> <p>26 - Check Valve (Auxiliary Flow Combining Circuit)</p> <p>27 - Check Valve (Bucket Flow Combining Circuit)</p> <p>28 - Flow Combiner Valve</p> <p>29 - Check Valve (Flow Combiner Valve Circuit)</p> <p>30 - Check Valve (Main Relief Pressure Flow Combining Circuit)</p> <p>31 - Main Relief Valve</p> <p>32 - Load Check Valve (Bucket Parallel Circuit)</p> <p>33 - Bucket Regenerative Valve (Switch Valve)</p> <p>34 - Bucket Regenerative Valve (Check Valve)</p> | <p>35 - Overload Relief Valve (Bucket Roll-Out)</p> <p>36 - Overload Relief Valve (Bucket Roll-In)</p> <p>37 - Boom Flow Rate Control Valve (Switch Valve)</p> <p>38 - Boom Flow Control Valve (Poppet Valve)</p> <p>39 - Overload Relief Valve (Boom Lower)</p> <p>40 - Overload Relief Valve (Boom Raise)</p> <p>41 - Boom Anti-Drift Valve (Switch Valve)</p> <p>42 - Boom Anti-Drift Valve (Check Valve)</p> <p>43 - Check Valve (Arm Make-Up Circuit)</p> <p>44 - Arm Flow Rate Control Valve (Switch Valve)</p> <p>45 - Arm Flow Rate Control Valve (Poppet Valve)</p> |
|--|---|--|--|

TROUBLESHOOTING / Component Layout

Pilot Valve Side

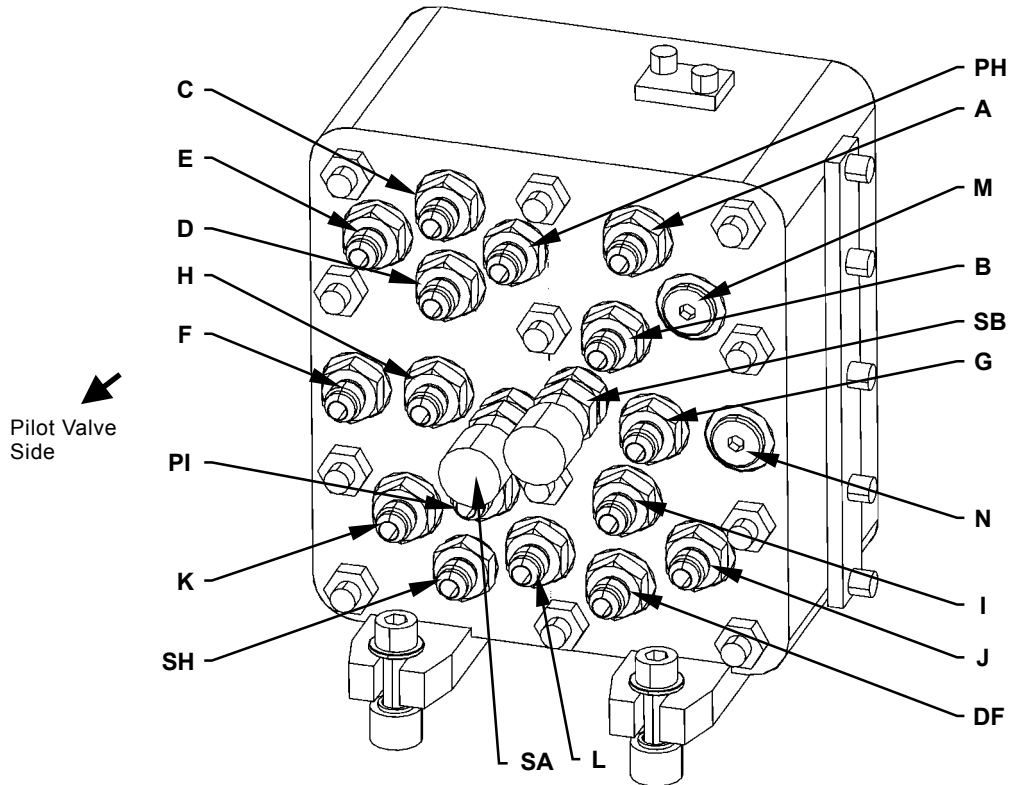

T1J1-03-06-002

Control Valve Side

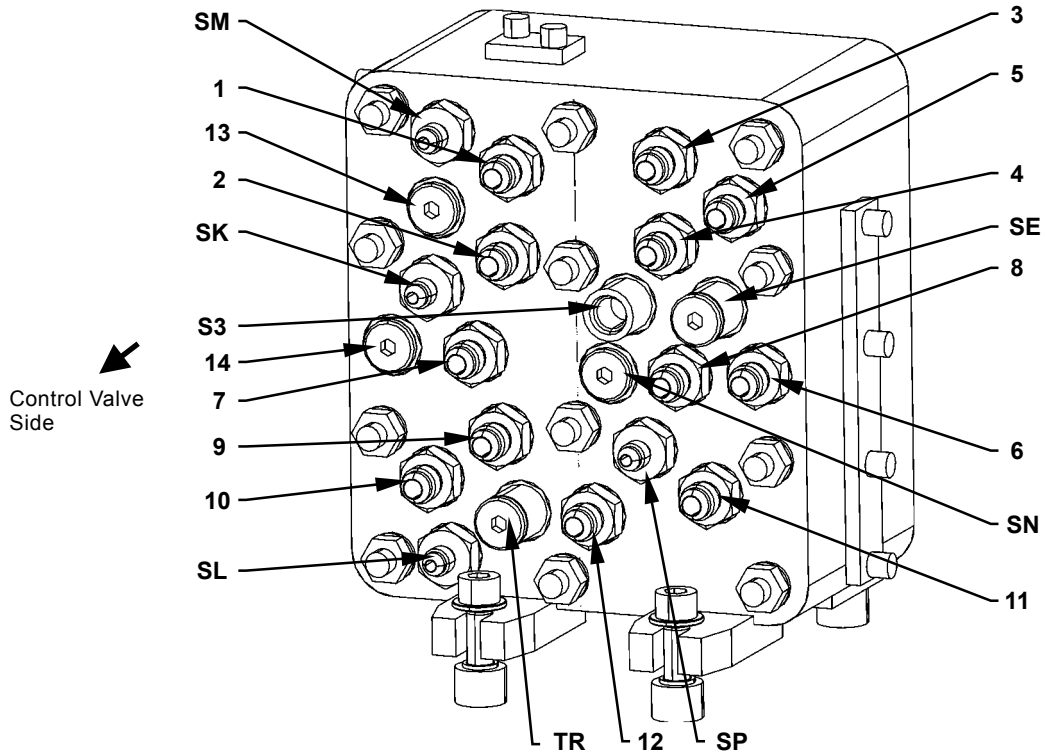

T1J1-03-06-003

TROUBLESHOOTING / Troubleshooting A

Symptoms in Machine Operation When Trouble Occurs.	Remedy for Dr. ZX	Remedy	Reference Page
• Pump 2 control is impossible.	Retry Diagnostic Procedure B	• Check Harness	T5-6-66
• Pump 2 control is impossible.	Retry Diagnostic Procedure B	• Check Harness	T5-6-66
• Boom flow rate control valve control is not operated.	Retry Diagnostic Procedure B	• Check Harness	T5-6-67
• Boom flow rate control valve control is not operated.	Retry Diagnostic Procedure B	• Check Harness	T5-6-67
• Increasing pressure selection is impossible.	Retry Diagnostic Procedure B	• Check Harness	T5-6-68
• Increasing pressure selection is impossible.	Retry Diagnostic Procedure B	• Check Harness	T5-6-68
• Travel mode selection is impossible.	Retry Diagnostic Procedure B	• Check Harness	T5-6-69
• Travel mode selection is impossible.	Retry Diagnostic Procedure B	• Check Harness	T5-6-69
• Pump 1 control is impossible.	Retry Diagnostic Procedure B	• Check Harness	T5-6-70
• Pump 1 control is impossible.	Retry Diagnostic Procedure B	• Check Harness	T5-6-70
• Fan control is impossible.	Retry Diagnostic Procedure B	• Check Harness	T5-6-71
• Fan control is impossible.	Retry Diagnostic Procedure B	• Check Harness	T5-6-71
-	Retry Diagnostic Procedure B	• Check Harness • Replace Boom Bottom Pressure Sensor	T5-6-72
-	Retry Diagnostic Procedure B	• Check Harness • Replace Boom Bottom Pressure Sensor	T5-6-72
• Overheat prevention control of hydraulic oil is impossible. • Maximum fan speed • Drive torque of pump is reduced.	Retry Diagnostic Procedure B	• Check Harness • Replace Hydraulic Oil Temperature Sensor	T5-6-73
• Overheat prevention control of hydraulic oil is impossible. • Maximum fan speed • Drive torque of pump is reduced.	Retry Diagnostic Procedure B	• Check Harness • Replace Hydraulic Oil Temperature Sensor	T5-6-73

TROUBLESHOOTING / Troubleshooting A

Symptoms in Machine Operation When Trouble Occurs.	Remedy for Dr. ZX	Remedy	Reference Page
<ul style="list-style-type: none"> • A/I cannot be released by bucket roll-out operation. • Flow rate of lever regulated pump control becomes maximum by bucket roll-out operation. • Boom mode selector control is impossible by bucket roll-out operation. • Boom flow rate control valve control is not operated. • Engine speed is lower than speed at E mode. 	Retry Diagnostic Procedure B	<ul style="list-style-type: none"> • Check Harness • Replace Bucket Roll-Out Pilot Pressure Sensor 	T5-6-85
<ul style="list-style-type: none"> • A/I cannot be released by bucket roll-out operation. • Flow rate of lever regulated pump control becomes maximum by bucket roll-out operation. • Boom mode selector control is impossible by bucket roll-out operation. • Boom flow rate control valve control is not operated. • Engine speed is lower than speed at E mode. 	Retry Diagnostic Procedure B	<ul style="list-style-type: none"> • Check Harness • Replace Bucket Roll-Out Pilot Pressure Sensor 	T5-6-85
<ul style="list-style-type: none"> • Speed at HP mode does not increase by boom lower operation. • A/I cannot be released by boom lower operation. • Boom mode selector control is impossible by boom lower operation. • Boom flow rate control valve control is not operated. • Engine speed is lower than speed at E mode. 	Retry Diagnostic Procedure B	<ul style="list-style-type: none"> • Check Harness • Replace Boom Lower Pilot Pressure Sensor 	T5-6-86
<ul style="list-style-type: none"> • Speed at HP mode does not increase by boom lower operation. • A/I cannot be released by boom lower operation. • Boom mode selector control is impossible by boom lower operation. • Boom flow rate control valve control is not operated. • Engine speed is lower than speed at E mode. 	Retry Diagnostic Procedure B	<ul style="list-style-type: none"> • Check Harness • Replace Boom Lower Pilot Pressure Sensor 	T5-6-86

TROUBLESHOOTING / Troubleshooting A

Presumptive Symptoms in Real Machine Operation	Assumptive Conditions at Back-up	Fault Code (Tech 2)	Reference Page on Engine Troubleshooting Manual
Vary depending on setting	Switched to drive control by accelerator sensor input voltage	U2104	1E-529
Vary depending on setting	Switched to drive control by accelerator sensor input voltage	U2106	1E-534
<ul style="list-style-type: none"> • Intense engine vibration • Rough idling • Output lowering • Blow up fault 	• Injection for cylinder #5	P0201	1E-273
<ul style="list-style-type: none"> • Intense engine vibration • Rough idling • Output lowering • Blow up fault 	• Injection for cylinder #3	P0202	1E-278
<ul style="list-style-type: none"> • Intense engine vibration • Rough idling • Output lowering • Blow up fault 	• Injection for cylinder #6	P0203	1E-283
<ul style="list-style-type: none"> • Intense engine vibration • Rough idling • Output lowering • Blow up fault 	• Injection for cylinder #2	P0204	1E-288
<ul style="list-style-type: none"> • Intense engine vibration • Rough idling • Output lowering • Blow up fault 	• Injection for cylinder #4	P0205	1E-293
<ul style="list-style-type: none"> • Intense engine vibration • Rough idling • Output lowering • Blow up fault 	• Common 1 stop (#1, #2, #3 cylinders stopped)	P0206	1E-298
<ul style="list-style-type: none"> • Output lowering • White smoke emission • Intense engine vibration is possible. • Engine stall is possible (restart is possible when G sensor is normal.) 	• Control based on G sensor when G sensor is normal	P0335	1E-319
<ul style="list-style-type: none"> • Output lowering • White smoke emission • Intense engine vibration is possible. • Engine stall is possible (restart is possible when G sensor is normal.) 	• Control based on G sensor when G sensor is normal	P0336	1E-325
• Operability is not affected.	• No back-up	P0650	1E-397

TROUBLESHOOTING / Troubleshooting A

MC FAULT CODE 11004

Fault Code	Trouble	Cause
11004-2	Abnormal CAN Communication	Faulty MC

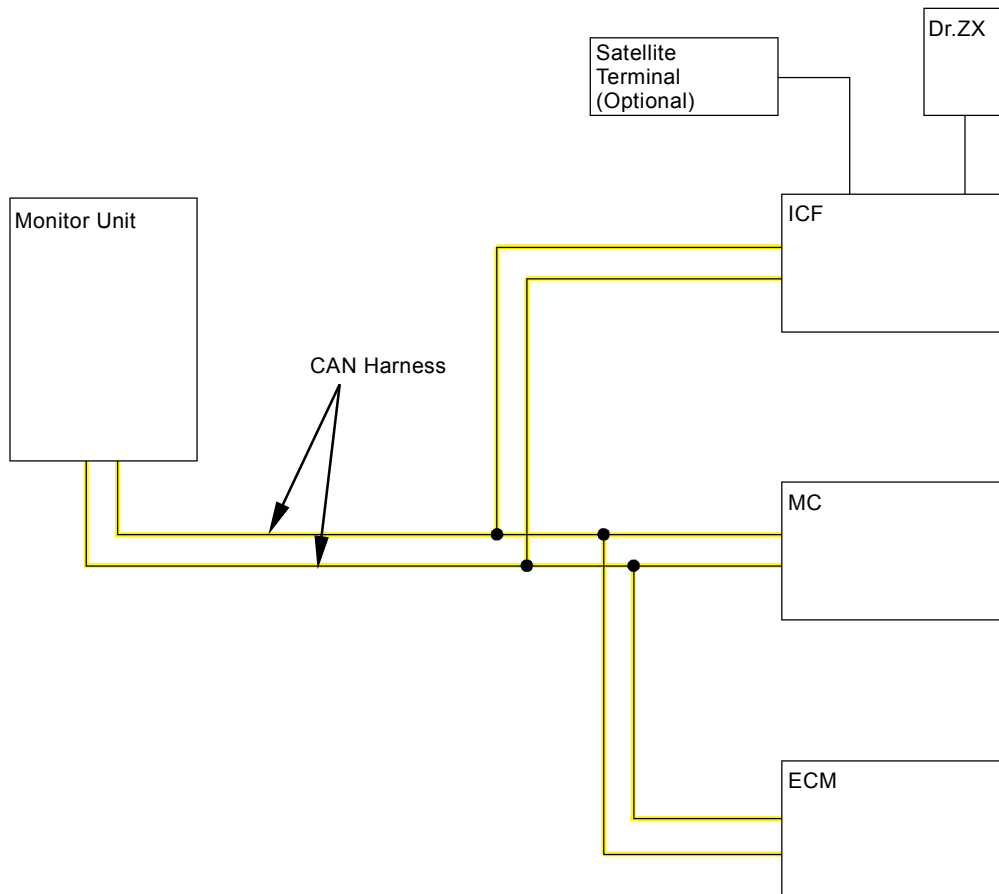

T1J1-02-01-004

- Check CAN harness between each controller.
(Refer to "CAN Harness Check (T5-6-40 to 59)").

TROUBLESHOOTING / Troubleshooting A

- ECM

Between CAN Circuit (High Side) and Ground Circuit

Check for continuity between terminals #18 and #1 of harness end of connector.

Check for continuity between terminals #18 and #3 of harness end of connector.

Check for continuity between terminals #18 and #4 of harness end of connector.

Check for continuity between terminals #18 and #43 of harness end of connector.

Check for continuity between terminals #18 and #62 of harness end of connector.

ECM
Connector
(Harness end)

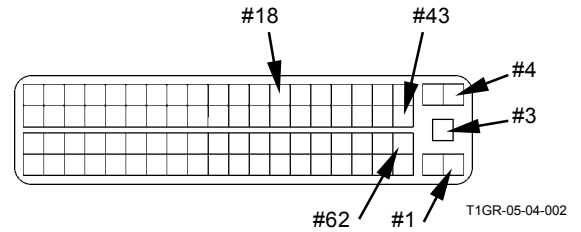

Between CAN Circuit (Low Side) and Ground Circuit

Check for continuity between terminals #37 and #1 of harness end of connector.

Check for continuity between terminals #37 and #3 of harness end of connector.

Check for continuity between terminals #37 and #4 of harness end of connector.

Check for continuity between terminals #37 and #43 of harness end of connector.

Check for continuity between terminals #37 and #62 of harness end of connector.

ECM
Connector
(Harness end)

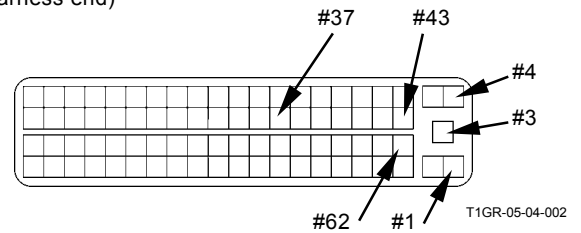

TROUBLESHOOTING / Troubleshooting A

- Connector ICF-C
Check for continuity between terminals #C5 and #C11 of harness end of connector ICF-C in ICF.

ICF
Connector ICF-C
(Harness end)

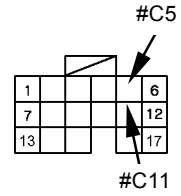

T1V1-05-04-002

- Connector Monitor-B in Monitor Unit
Check for continuity between terminals #B6 and #B7 of harness end of connector monitor-B in the monitor unit.

Monitor Unit
Connector Monitor-B
(Harness end)

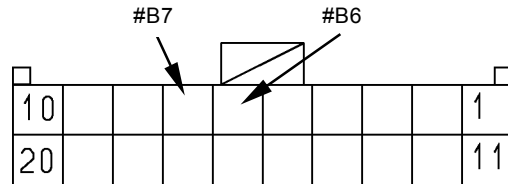

T183-05-04-013

TROUBLESHOOTING / Troubleshooting A

MC FAULT CODE 11405

Fault Code	Trouble	Cause
11405-3	Abnormal Feedback High Current of Solenoid Valve Unit (SI) (Travel Motor Displacement Angle Control)	Current: Higher than 920 mA
11405-4	Abnormal Feedback Low Current of Solenoid Valve Unit (SI) (Travel Motor Displacement Angle Control)	Current: Less than 56 mA

IMPORTANT: In case switching the connector in solenoid valve and performing the diagnosing, check for continuity in the solenoid before switching. When the connector is switched and the engine starts with the solenoid shorted, normal solenoid valve and MC may be damaged.

Reference value:

Pump control solenoid valve: 17.5 Ω at 20 °C

4-spool solenoid valve unit: 18.5 Ω at 20 °C

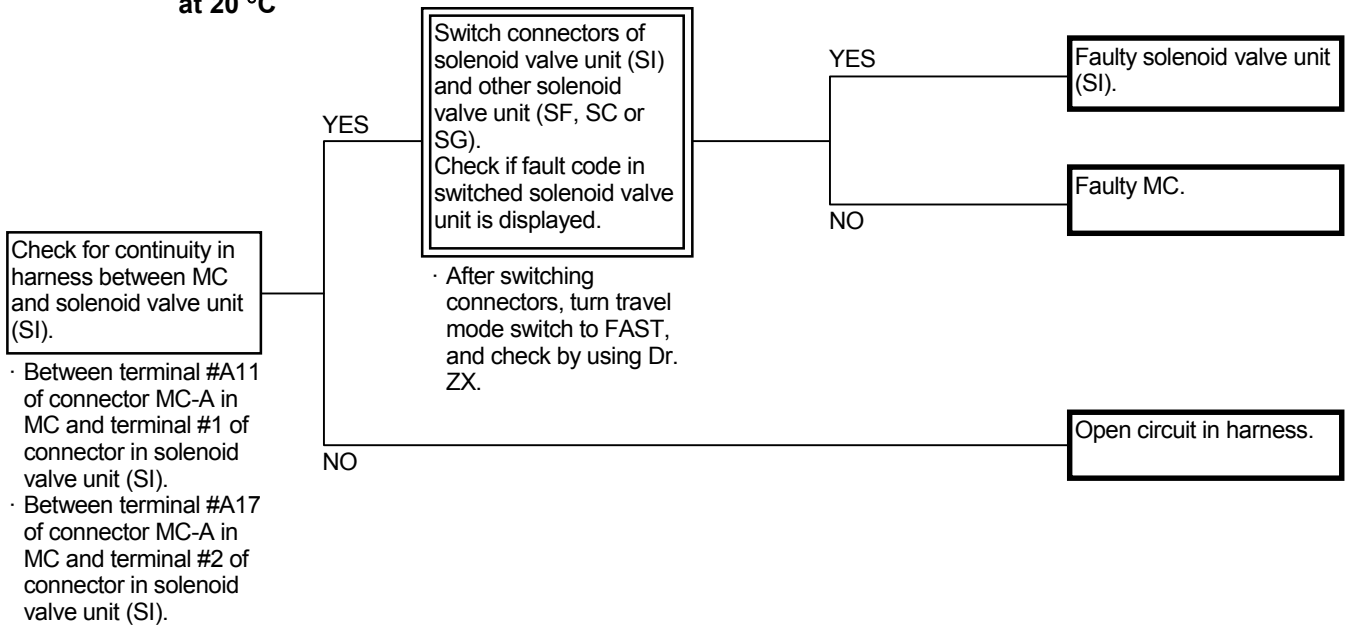

Connector (Harness end of connector viewed from the open side)

MC
Connector MC-A

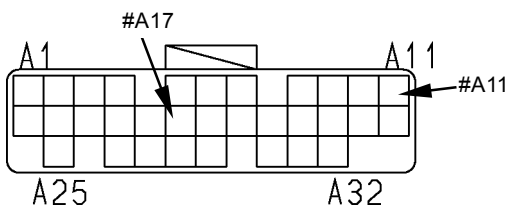

Solenoid Valve Unit (SI)



T1V1-05-04-003

T183-05-04-008

TROUBLESHOOTING / Troubleshooting A

MC FAULT CODE 11989

Fault Code	Trouble	Cause
11989-3	Abnormal Feedback High Current of Solenoid Valve Unit (SC) (Boom Mode Control)	Current: Higher than 920 mA
11989-4	Abnormal Feedback Low Current of Solenoid Valve Unit (SC) (Boom Mode Control)	Current: Less than 56 mA

IMPORTANT: In case switching the connector in solenoid valve and performing the diagnosing, check for continuity in the solenoid before switching. When the connector is switched and the engine starts with the solenoid shorted, normal solenoid valve and MC may be damaged.

Reference value:

Pump control solenoid valve: 17.5 Ω
at 20 °C

4-spool solenoid valve unit: 18.5 Ω
at 20 °C

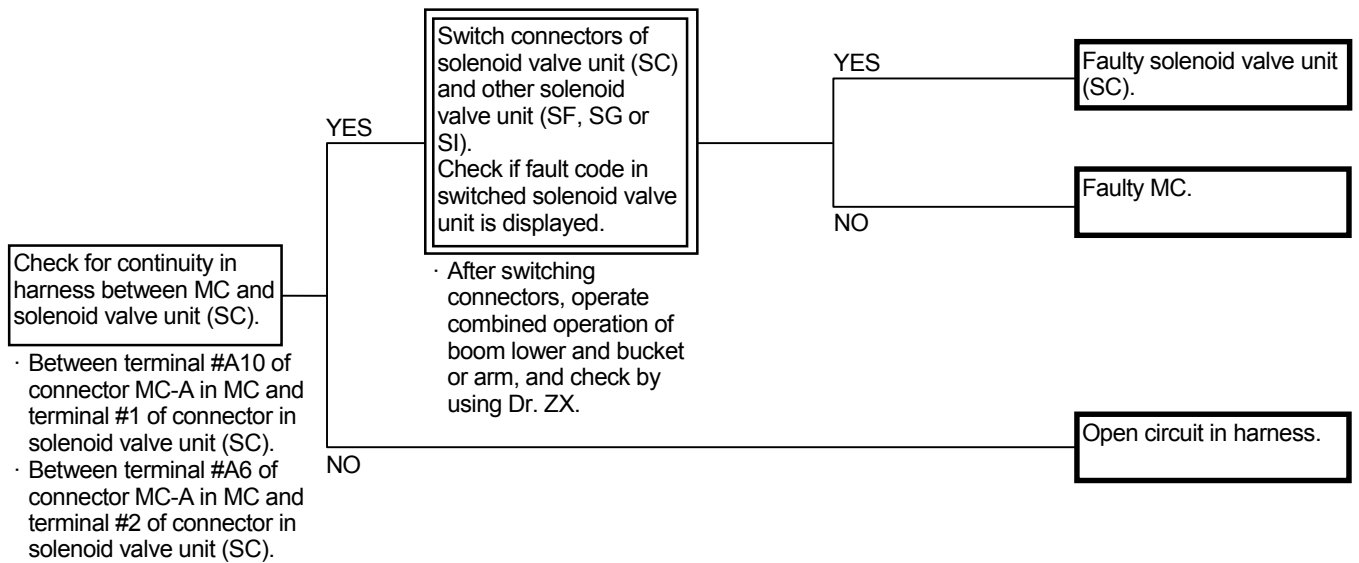

Connector (Harness end of connector viewed from the open side)

MC
Connector MC-A

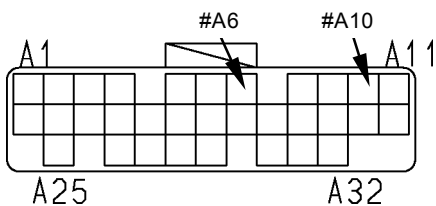

Solenoid Valve Unit (SC)

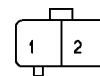

T183-05-04-008

T1V1-05-04-003

TROUBLESHOOTING / Troubleshooting A

ICF FAULT CODES 14000 to 14003

Fault Code	Trouble	Remedy
14000-2	Abnormal CAN Communication	Execute retry B in self-diagnosing. If this error code is displayed after retry, check the following item. <ul style="list-style-type: none">• Check the CAN communication line (harness).
14001-2	Flash Memory: Read / Write Error	Execute retry B in self-diagnosing and execute the following item. <ul style="list-style-type: none">• Execute "Information C/U: Initialize".
14002-2	External RAM: Read / Write Error	
14003-2	EEPROM: Sum Check Error	Execute retry B in self-diagnosing. If this error code is displayed after retry, check the following item. <ul style="list-style-type: none">• Execute "Control Data: Initialize".• Execute "Enter Model and Serial No.". Then, execute self-diagnosing and execute retry B.

TROUBLESHOOTING / Troubleshooting A

MONITOR UNIT FAULT CODE 13311

Fault Code	Trouble	Remedy
13311-3	Shorted Circuit in Fuel Level Sensor	Check the fuel level sensor and harness.
13311-4	Open Circuit in Fuel Level Sensor	Check the fuel level sensor and harness.

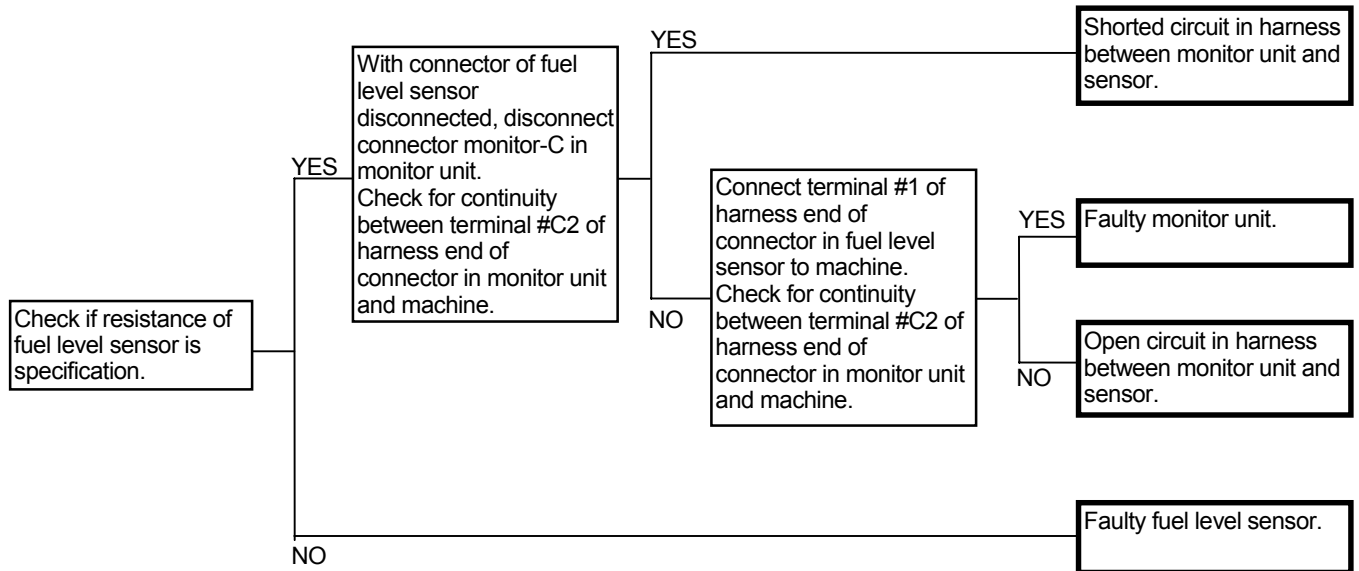

Fuel Level Sensor

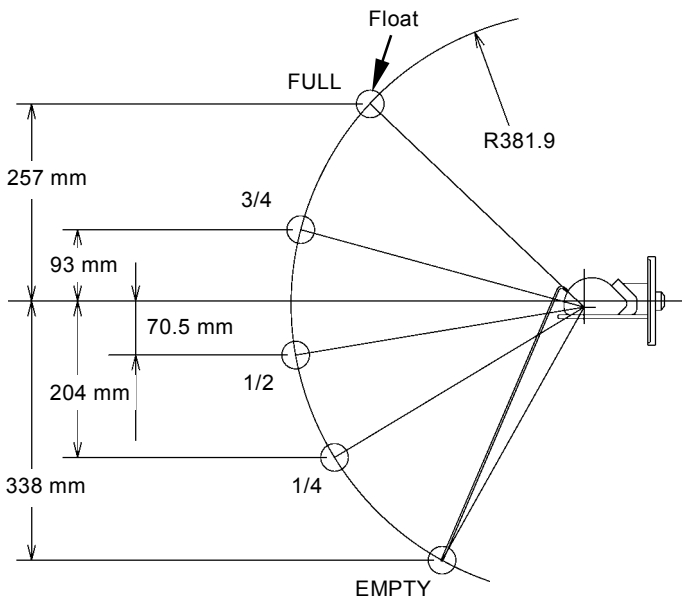

T178-05-05-001

Float Position	Resistance (Ω)
Upper Limit (FULL)	10^{+0}_{-4}
3/4	26
1/2	38 ± 5
1/4	53
Alarm Level	85 ± 3
Lower Limit (EMPTY)	90^{+10}_{-0}

Connector (Harness end of connector viewed from the open end)

Monitor Unit
Connector Monitor-C

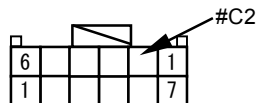

Fuel Sensor

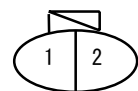

TROUBLESHOOTING / Troubleshooting B

Solenoid Valve Unit (SC)	Pump 1 Control Solenoid Valve	Pump 2 Control Solenoid Valve
<ul style="list-style-type: none"> Controls boom mode selector control. Reduces boom overload relief pressure to 11.8 MPa (120 kgf/cm²) at 110 L/min. 	<ul style="list-style-type: none"> Changes pump 1 swash angle. 	<ul style="list-style-type: none"> Changes pump 2 swash angle.
<ul style="list-style-type: none"> Boom overload relief pressure is not reduced. 	<ul style="list-style-type: none"> Pump control is inoperable. 	<ul style="list-style-type: none"> Pump control is inoperable.
<ul style="list-style-type: none"> Even if boom mode selector switch is turned ON, boom lower power and vibration cannot be controlled. 	<ul style="list-style-type: none"> If harness is disconnected and solenoid valve is faulty, flow rate of pump 1 becomes minimum. 	<ul style="list-style-type: none"> If harness is disconnected and solenoid valve is faulty, flow rate of pump 2 becomes minimum.
Fault code 11989 is displayed.	Fault code 11410 is displayed.	Fault code 11400 is displayed.
Monitor Item: Boom Mode Control Pressure	Monitor Item: Pump 1 Regulator Valve Current	Monitor Item: Pump 2 Regulator Valve Current
<ul style="list-style-type: none"> Install lamp harness (ST 7130). Check output signals from MC and harness condition. 	-	-
-	-	-
<ul style="list-style-type: none"> Judge if solenoid valve is broken or harness is disconnected by switching with another solenoid valve unit harness. 	<ul style="list-style-type: none"> Judge if solenoid valve is broken or harness is disconnected by switching with another solenoid valve harness. (Switch harness of delivery pressure sensor and regulator pressure sensor.) 	<ul style="list-style-type: none"> Judge if solenoid valve is broken or harness is disconnected by switching with another solenoid valve harness. (Switch harness of delivery pressure sensor and regulator pressure sensor.)
T2-1	T2-1	T2-1

TROUBLESHOOTING / Troubleshooting B

(Blank)

TROUBLESHOOTING / Troubleshooting B

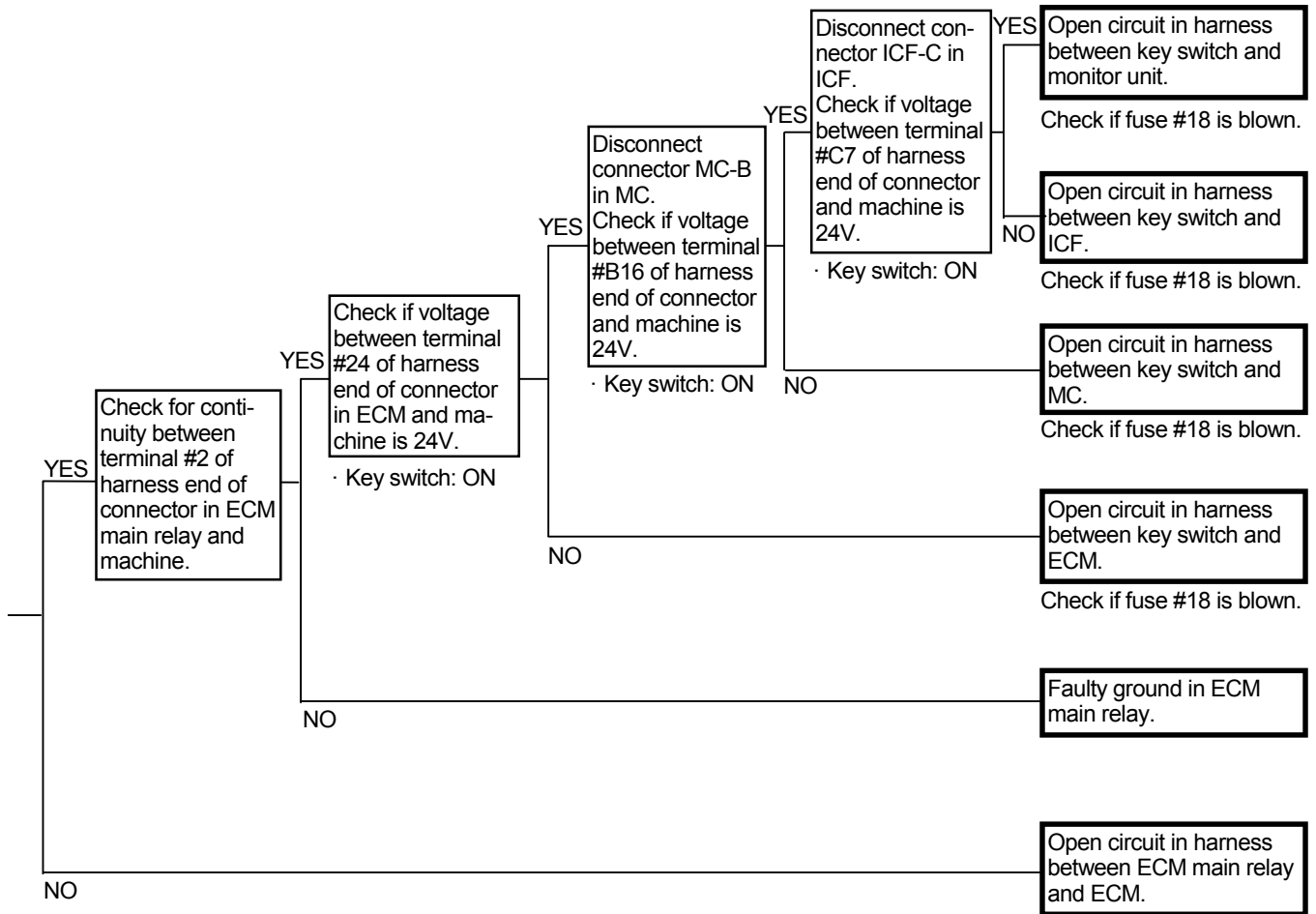

Connector MC-B

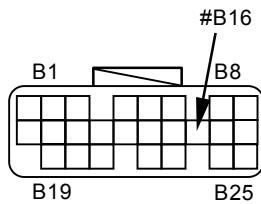

Connector ICF-C

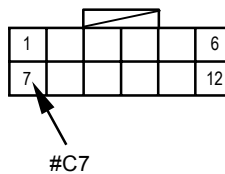

T1GR-05-04-002

TROUBLESHOOTING / Troubleshooting B

E-9 Engine speed does not increase even if attachment is operated in attachment mode.

Related Fault Code	Trouble	Reference Page
MC 11004	CAN Communication Error	T5-6-39

- In case trouble symptoms E-1 to E-11 are recognized, perform the troubleshooting of these troubles first.
- Even if the failure in pressure sensor (attachment) and power mode switch may have relevance to the malfunction of attachment operation speed increase control. However, if these sensor and switches fail, other operating functions will also be affected.
- Refer to the pages for Attachment Operation Speed Increase Control in the SYSTEM / Control System group in the T/M (Operational Principle).
- Check the wiring connections first.

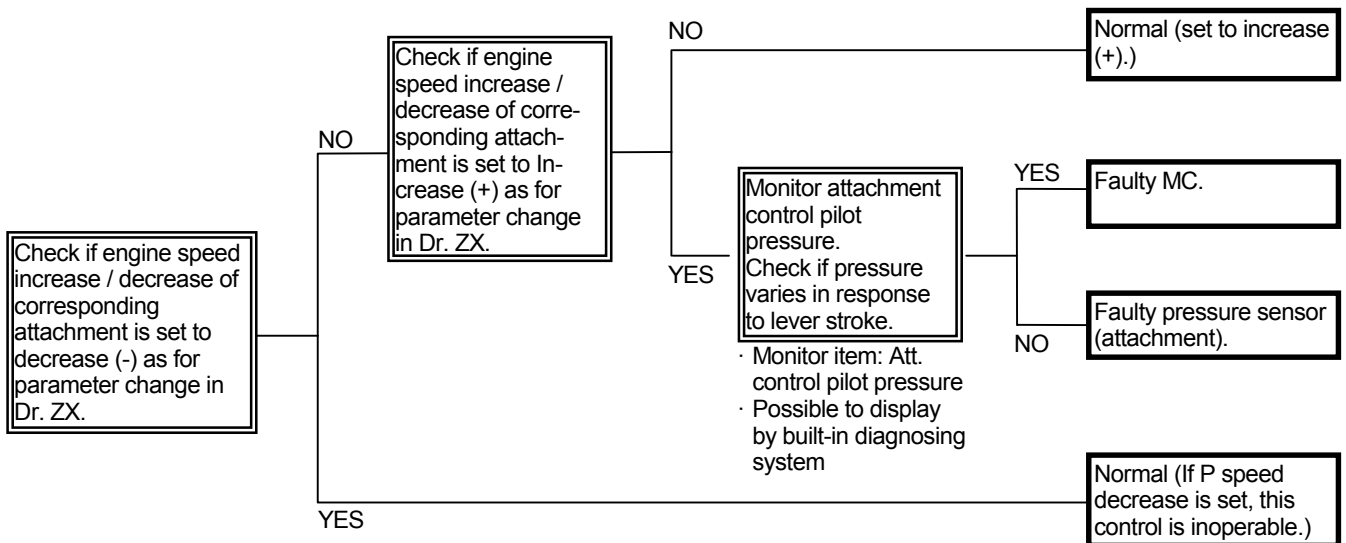

TROUBLESHOOTING / Troubleshooting B

A-7 Fan rotation speed remains unchanged at maximum.

- Check if the fault code is not displayed first.
- If the sensor corresponding to fan pump flow rate control is abnormal, fan rotation speed becomes maximum.
- If all actuator speeds are slow, refer to A-2.

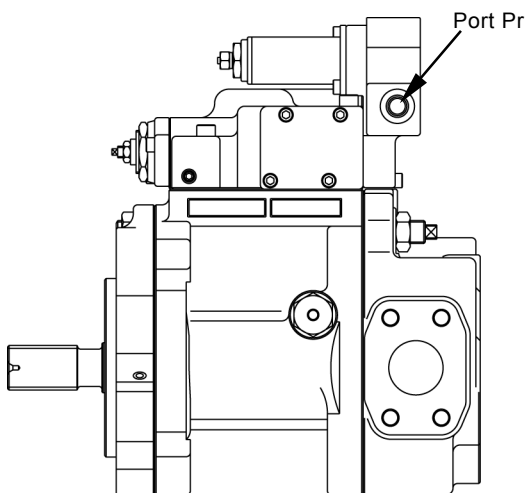
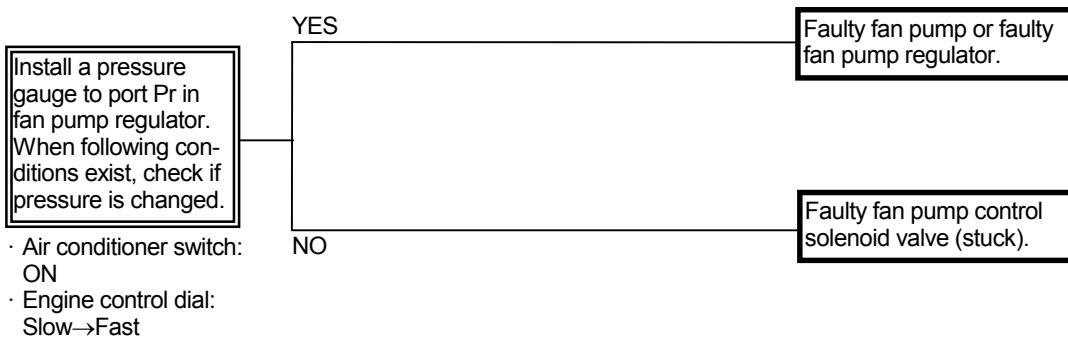

T1J1-05-07-001

TROUBLESHOOTING / Troubleshooting B

F-6 Even if the boom mode selector switch is pushed, machine is raised off ground.

Related Fault Code	Trouble	Reference Page
MC 11989	Abnormal Solenoid Valve Unit (SC)	T5-6-79

- Refer to the pages for Boom Mode Selector Control in SYSTEM / Control System group in T/M (Operational Principle).
- Check the wiring connections first.

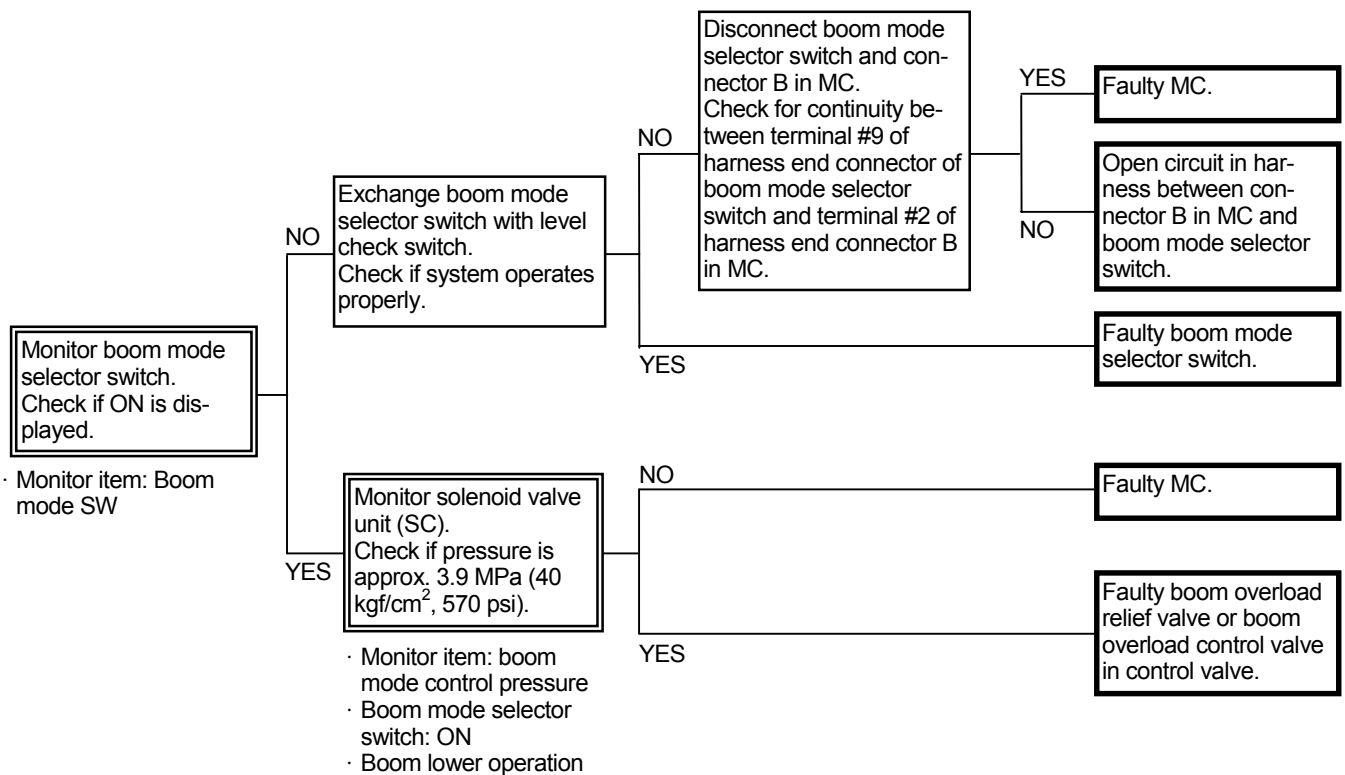

Connector (Harness end connector viewed from the open end side)

Boom Mode Selector Switch

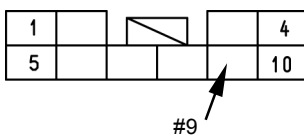

T1J1-05-07-003

MC Connector B

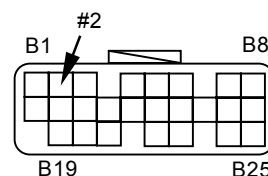

TROUBLESHOOTING / Troubleshooting B

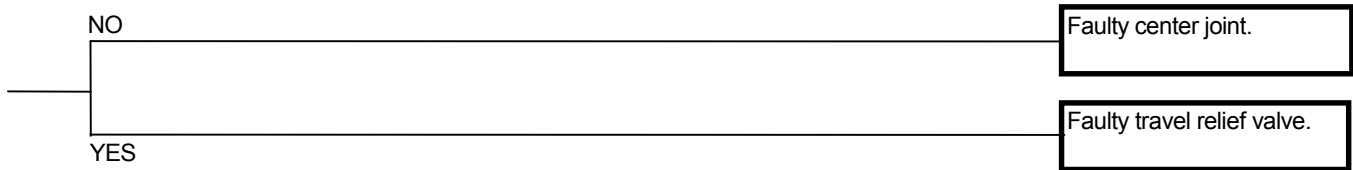
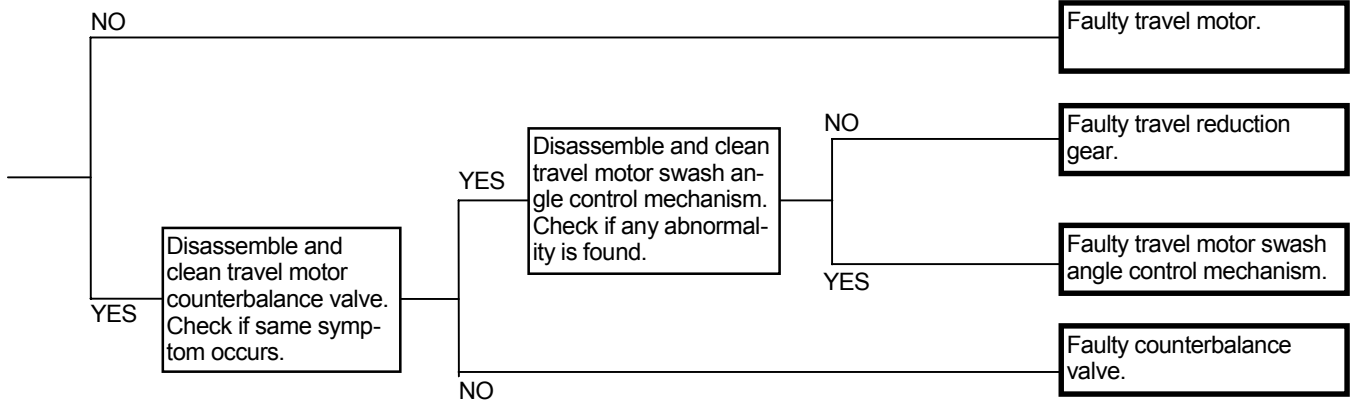

Arrangement of Pipe Line

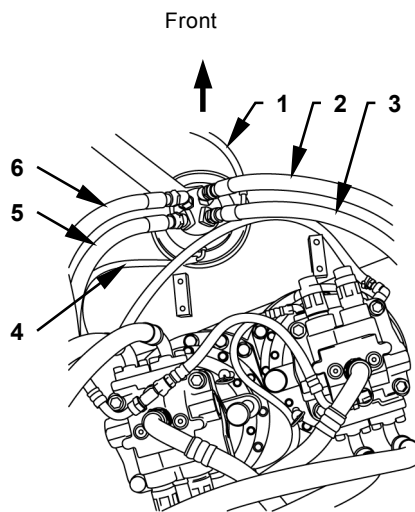

T1J1-05-07-004

- | | | | |
|----------------------------|---------------------------------|---------------------------|---------------------------|
| 1 - Drain | 3 - Right Travel (Reverse) | 5 - Left Travel (Reverse) | 6 - Left Travel (Forward) |
| 2 - Right Travel (Forward) | 4 - Pilot (Travel Speed Change) | | |

TROUBLESHOOTING / Troubleshooting B

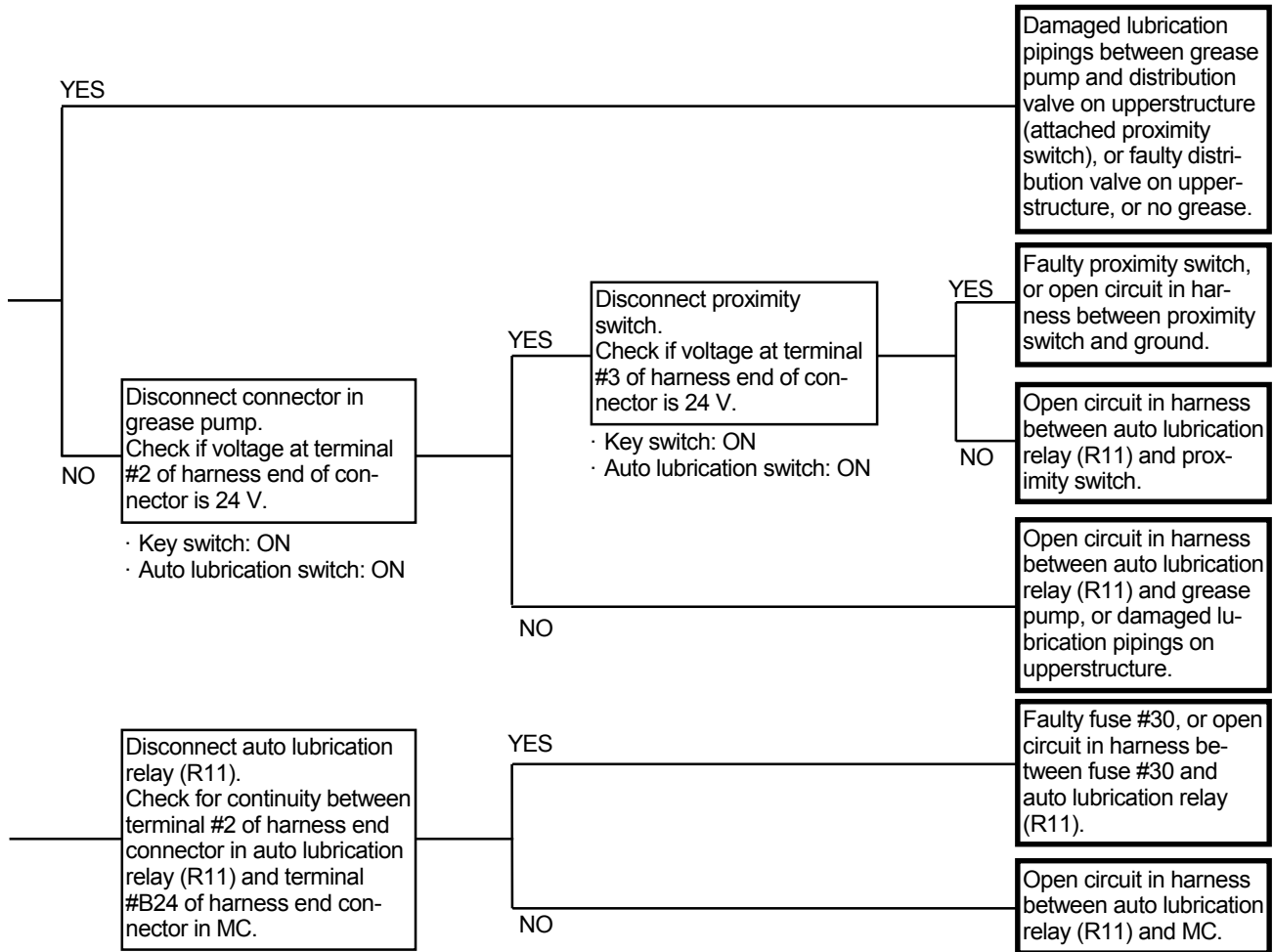

Connector (Harness end of connector viewed from the open side)

Grease Pump Proximity Switch

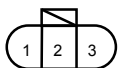

Auto Lubrication Relay (R11)

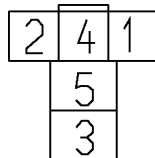

T183-05-04-003

TROUBLESHOOTING / Troubleshooting B

※ Please fill in all sections and return this AIR CONDITIONER TROUBLE REPORT to the related post / after experiencing a problem with your machine's air conditioning system.

< AIR CONDITIONER TROUBLE REPORT >

File No. _____

(1) What

Model	(Serial No. _____)		
Operation Type	Manual	Semi-Auto	Full-Auto
Delivery Date	Year	Month	

Checked by:

(2) When

Date	Year	Month	Day	Operating Hour (_____ h)
Time	Morning	Daytime	Evening	Night
Frequency	Every Day	Once a Week	Once a Month	Times per

(3) Where

Job Site Address	State	County	Town
Access Road Condition	Paved	Not Paved (Gravel	Sand Soil)

(4) How (Operating Conditions)

Weather	Fine	Cloudy	Rain	Snow	
Atmospheric Temperature	Very Hot	Hot	Cold	Very Cold	
Operating Conditions	Parking	Traveling	Working		
Control Panel	Temperature Control	Paint blanks equal to red indicators. / Fill in set-temperature when full-auto operation			
	A/C	ON	OFF		
	Air Induction	Re-Circulation	Fresh Air Circulation		
	AUTO	ON	OFF	Not Available	
	Fill following items when operated in manual mode or when manual control type unit is used.				
	Vent Position	Front	Front / Rear	Foot	Front / Rear and Foot
Fan	First	Second	Third	Fourth Fifth Sixth	

(5) How (Problem Symptom)

Abnormal Compressor Operation	
Symptom	Not turned ON
	Not turned OFF
	Others
Uncontrollable air temperature	
Symptom	No cool air
	No warm air
	Others
Uncontrollable air volume	
Symptom	Air flows in Hi mode only
	No air flows
	Small air volume
	Others
Uncontrollable vent hole	
Symptom	Vent hole isn't selected
	Others
Abnormal panel indication	
Faulty Indicator	Vent Hole
	A/C
	AUTO
	Fresh Air Circulation
	Fan OFF
	Fan (Lo • • • Hi)
	Temperature Control
Symptom	Stays OFF
	Stays ON
	Blinks
	Others

<Check Result>

(1) Is problem reproducible ?

Reproducible
Not reproducible

(2) Pressure (To be measured at gauge manifold)

Low Pressure
High Pressure

(3) Which parts have been replaced ?

1	
2	

* Before replacing the control amplifier, be sure to check that the connectors are correctly connected while repeatedly disconnecting and reconnecting connectors.

TROUBLESHOOTING / Troubleshooting B

CHARGE AIR CONDITIONER WITH REFRIGERANT

Necessity of Purging

Make sure to purge the air conditioner circuit with a vacuum before charging with refrigerant (R134a) because the following problems can arise if air or other gases remain in the A/C circuit.

1. Pressure rise in the high pressure side:

If air remains in the air conditioner circuit, this disturbs the heat exchange between refrigerant and air in the condenser, causing pressure to rise in the high pressure side (compressor side). Usually, refrigerant gas is easily liquefied, however, air cannot be liquefied and remains as a gas in the condenser because the temperature at which air liquefies is extremely low. That is, liquidation of the refrigerant gas in the condenser decreases by the amount of air in the circuit, and the gas pressure in the high pressure side increases accordingly.

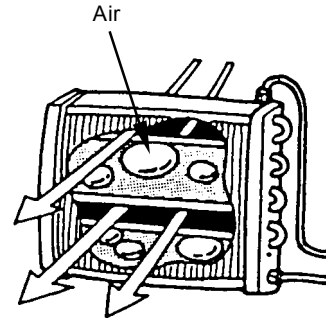

Pressure increases if air remains in the air conditioner circuit.

W115-02-10-001

2. Metal corrosion:

If air remains in the air conditioner circuit, a chemical reaction between refrigerant and moisture in the air takes place, and as a result, hydrochloric acid, that corrodes metals such as aluminum, copper and iron, is produced.



Hydrochloric acid corrodes metals if moisture exists.

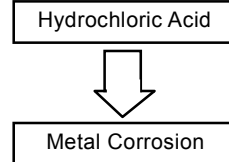

W115-02-10-002

3. Plugging of the expansion valve by moisture:

When high pressure refrigerant gas passes through the expansion valve, gas pressure decreases and temperature drops. Moisture included in high pressure refrigerant gas in the air conditioner circuit freezes at the expansion valve orifice, plugging refrigerant flow. Operation of the air conditioner becomes unstable and cooling efficiency lowers.

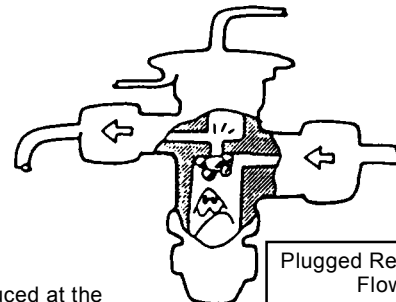

Ice produced at the expansion valve disturbs refrigerant flow, lowering cooling efficiency.

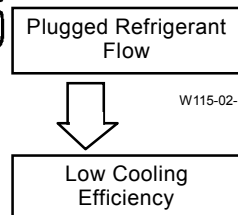

W115-02-10-003

TROUBLESHOOTING / Troubleshooting B

Applicability of Switch-Check Method

Fault Code	Trouble	Applicability
11000-2	Abnormal EEPROM	Not Applicable
11001-2	Abnormal RAM	
11002-2	Abnormal A/D Converter	
11003-3	Abnormal Sensor Voltage	
11004-2	CAN Communication Error	Not Applicable
11101-3	EC Dial sensor Circuit High Input	Not Applicable
11101-4	EC Dial sensor Circuit Low Input	
11200-3	Pump 1 Delivery Pressure Sensor Circuit High Input	Applicable (Harness / Sensor)
11200-4	Pump 1 Delivery Pressure Sensor Circuit Low Input	
11202-3	Pump 2 Delivery Pressure Sensor Circuit High Input	
11202-4	Pump 2 Delivery Pressure Sensor Circuit Low Input	
11301-3	Swing Pilot Pressure Sensor Circuit High Input	Applicable (Harness / Sensor)
11301-4	Swing Pilot Pressure Sensor Circuit Low Input	
11302-3	Boom Raise Pilot Pressure Sensor Circuit High Input	
11302-4	Boom Raise Pilot Pressure Sensor Circuit Low Input	
11303-3	Arm Roll-in Pilot Pressure Sensor Circuit High Input	
11303-4	Arm Roll-in Pilot Pressure Sensor Circuit Low Input	
11400-3	Pump 2 Regulator Valve FB High Current	Applicable (Harness / Solenoid Valve)
11400-4	Pump 2 Regulator Valve FB Low Current	
11402-3	Boom Flow Control Valve FB High Current	Applicable (Harness / Solenoid Valve)
11402-4	Boom Flow Control Valve FB Low Current	
11404-3	Power Boost P/S Valve FB High Current	
11404-4	Power Boost P/S Valve FB Low Current	
11405-3	Travel Swash Angle P/S Valve FB High Current	
11405-4	Travel Swash Angle P/S Valve FB Low Current	

TROUBLESHOOTING / Electrical System Inspection

HOW TO TROUBLESHOOT ALTERNATOR MALFUNCTIONS

In general, the alternator alarm remains off when the alternator is generating power.

If the alternator alarm is displayed while the engine is running, the alternator might be defective.

How to check the circuit

1. Stop the engine. Turn the key switch to the ON position. Confirm that the alternator alarm comes on.
2. Measure the voltage between the B and the vehicle frame. If the measured voltage is around 24 V, the alternator circuit can be considered normal. If the measured voltage is low, a shortage in battery capacity or looseness of the wire connectors of the alternator circuit might be the cause of the malfunction. When the voltage is 0 V, the wiring between the fuse box and alternator might be loose or disconnected. Also, the alternator cannot generate electricity if the ground line is disconnected.
3. Next, start the engine and measure the voltage generated while as the alternator rotates. As described above, measure the voltage between terminals B and the vehicle frame. If the voltage is around 28 V, the alternator is operating normally. If the rated voltage is not being generated, there is some trouble with the alternator or the regulator.

Monitor Unit

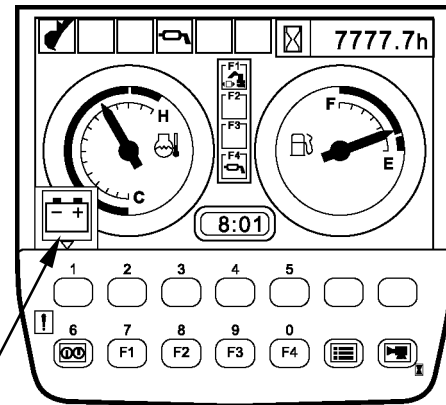

Alternator Alarm

T1J1-05-01-007

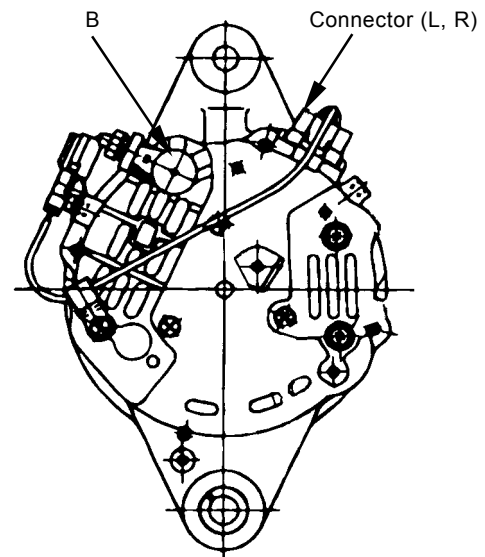

T16J-05-06-001

CLICK HERE TO **DOWNLOAD** THE COMPLETE MANUAL

- Thank you very much for reading the preview of the manual.
- You can download the complete manual from: www.heydownloads.com by clicking the link below



- Please note: If there is no response to CLICKING the link, please download this PDF first and then click on it.

CLICK HERE TO **DOWNLOAD** THE COMPLETE MANUAL