

Workshop Manual

AH250D/300D

Vol No.: W8TDE-00

CLICK HERE TO **DOWNLOAD** THE COMPLETE MANUAL

- Thank you very much for reading the preview of the manual.
- You can download the complete manual from: www.heydownloads.com by clicking the link below



- Please note: If there is no response to CLICKING the link, please download this PDF first and then click on it.

CLICK HERE TO **DOWNLOAD** THE COMPLETE MANUAL

If you spill acid on yourself:

- Flush your skin with water.
- Apply baking soda or lime to help neutralise the acid.
- Flush your eyes with water for 10 - 15 minutes and get medical attention immediately.

If acid is swallowed:

- Drink large amounts of water or milk.
- Then drink milk of magnesia, beaten eggs, or vegetable oil.
- Get medical attention immediately.

Wear Protective Equipment

Wear a hard hat, protective glasses and other protective equipment as required by the job conditions. Do not wear loose clothing or jewellery that can catch on controls or other parts of the machine.

When you drive connecting pins in or out, guard against injury from flying pieces of debris by wearing goggles or protective glasses. Prolonged exposure to loud noise can cause impairment or loss of hearing. Wear a suitable hearing protective device such as earmuffs or earplugs. Wear gloves when handling wire rope cable.

Use the Seat Belt

Use a seat belt at all times to minimise the chance of injury in an accident.

The seat belt must not be altered or modified in any way. Such changes can render the belt ineffective and unsafe.

The seat belt is designed and intended for the seat's occupant to be of adult build and for one occupant of the seat only.

Avoid High Pressure Fluids

Escaping fluid under pressure can penetrate the skin causing serious injury. Relieve the pressure before disconnecting hydraulic or other lines. Tighten all connections before applying pressure. Keep hands and body away from pinholes and nozzles which eject fluids under high pressure. Use a piece of cardboard or paper to search for leaks.

If any fluid is injected into the skin it must be surgically removed within a few hours by a doctor who is familiar with this type of injury or gangrene may result.

Stay Clear Of Moving Parts

Entanglements in moving parts can cause serious injury.

Stop engine before examining, adjusting or maintaining any part of the machine with moving parts.

Keep guards and shields in place. Replace any guard or shield that has been removed for access as soon as service or repair is complete.

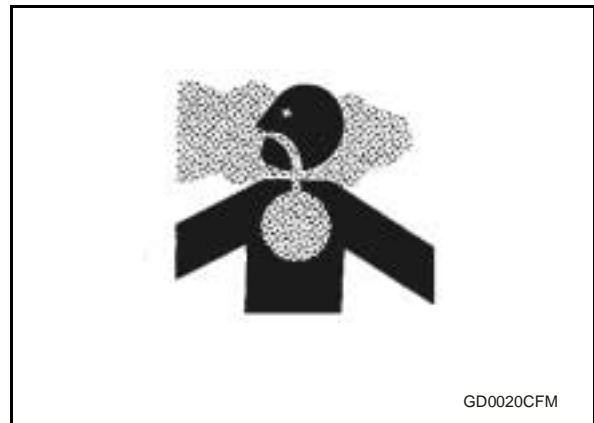
Beware of Toxic Fumes

Prevent asphyxiation. Engine exhaust fumes can cause sickness or death.

Operate only in well ventilated indoor areas. Avoid hazardous fumes by first removing paint on painted surfaces before welding.

Wear an approved respirator when sanding or grinding painted surfaces.

If a solvent or paint stripper is used, wash surface with soap and water. Remove solvent or paint containers before welding and allow at least 15 minutes before welding or heating.

TABLE OF CONTENTS

SECONDARY STEERING PUMP	283
SECTION 2. HYDRAULIC SYSTEM	287
STEERING VALVE	287
STEERING CYLINDER	290
CHAPTER 9. SERVICE BRAKES	295
SECTION 1. ACTIVE ELEMENTS	295
SERVICE BRAKES	295
SECTION 2. HYDRAULIC SYSTEM	299
BRAKE VALVE	299
CHAPTER 10. PARK BRAKE	303
SECTION 1. ACTIVE ELEMENTS	303
PARK BRAKE	303
CHAPTER 11. FRAME AND SUPPORTING STRUCTURE	307
SECTION 1. FRAME INSTALLATION	307
WELDING ON MACHINE	307
SEPARATE FRONT AND REAR FRAMES	307
CHAPTER 12. OPERATOR'S STATION	317
SECTION 1. CAB	317
CAB MOUNTINGS	317
SECTION 2. SEAT AND SEAT BELT	321
OPERATOR'S SEAT	321
SECTION 3. HEATING AND AIR CONDITIONING	323
REFRIGERANT CAUTIONS AND PROPER HANDLING	323
R134a REFRIGERANT OIL INFORMATION	324
CHAPTER 13. SHEET METAL AND STYLING	337
SECTION 1. BONNET OR ENGINE ENCLOSURE	337
BONNET	337
CHAPTER 14. MAIN HYDRAULIC SYSTEM	341
SECTION 1. HYDRAULIC SYSTEM	341
MAIN HYDRAULIC PUMP	341
SUCTION STRAINER	346
HYDRAULIC SYSTEM MANIFOLD ASSEMBLY	347
CHAPTER 15. PNEUMATIC SYSTEMS	353
SECTION 1. PUMPS AND DRIVES	353
AIR COMPRESSOR	353
SECTION 2. CONTROL VALVES	363

If degree of inclination for rear axle is not within specification then:

- To tilt rear axle forward, add shims, as necessary, equally between lower drag link and frame mount, on both cap screws, for each lower drag link.
- To tilt middle axle rearward, add shims, as necessary, equally between lower drag link and axle mount, on both cap screws, for each lower drag link.

Ensure all lower drag link socket head cap screws are lubricated and tightened to specification.

Drag Link Cap Screw Specification

Link or Stabilizer Cap Screw and Nut Torque - - - - -
-----620 Nm (457.289 lb-ft)

Carefully remove pinion shaft and calibration ring.

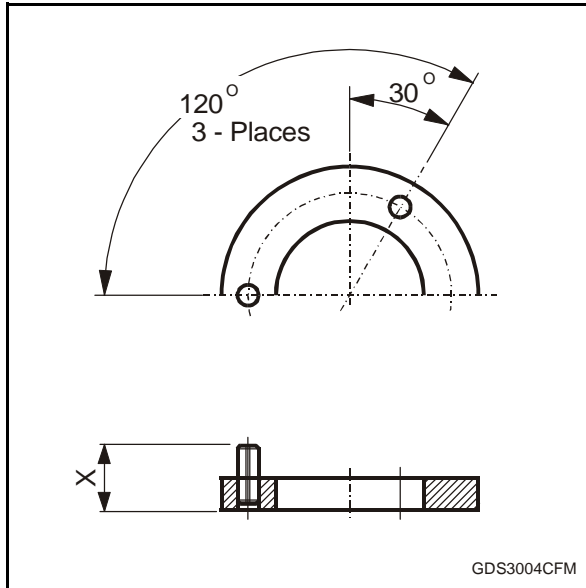

Measure calibration ring JDG1281 at all three pins and calculate an average dimension.

Install spacer (25) of this thickness on pinion shaft and install pinion shaft in housing.

Heat outer bearing and install on pinion shaft.

Apply cure primer and flexible form-in-place gasket to outside diameter of seal (26) and lube seal inner lip.

Install seal.

Install dust shield (27), bushing (28), washer (29), and nut (30) and tighten to specification.

Specification

Pinion Nut Torque----- 750 Nm (553 lb-ft)

Heat roller bearings (17 and 18) to 110°C (230°F) and install bearings on housing (10) and carrier cover (31).

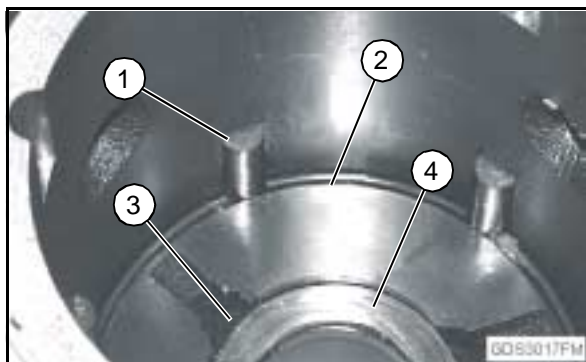

Install thrust washers (3 and 4) in housing.

Install lock ring (2) and dowel pins (1).

Lubricate and install disks in the following order: notched disk, notched disk, splined disk and notched disk.

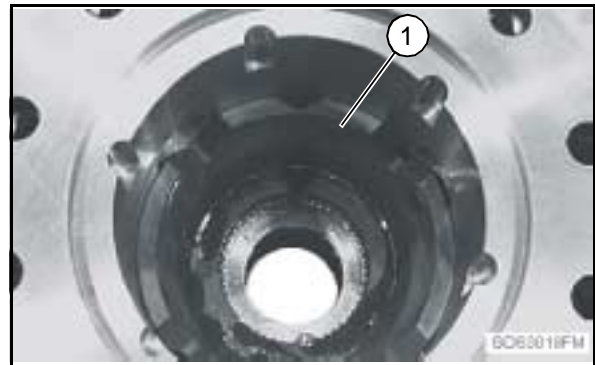

Install bevel gear housing (1) onto dowel pins.

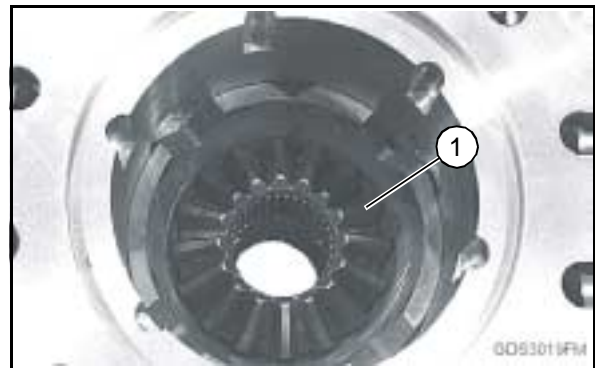

Install axle bevel gear (1). Ensure axle bevel gear engages both splined disks and contacts thrust washer.

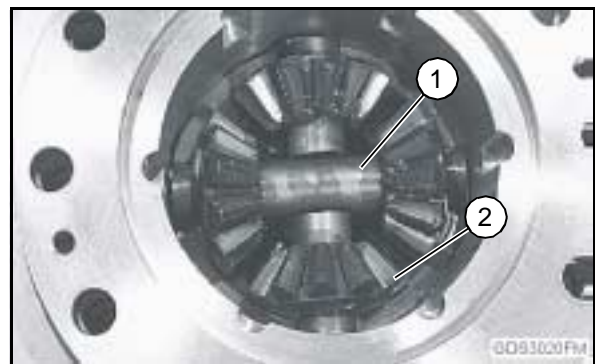

Lubricate and install bevel gears (2) and pinion cross shafts (1) as an assembly.

Subtract bearing cup height measurement from pinion bearing thickness measurement. Difference will be thickness of bearing shim required. If thickness is between shim sizes use greater size shim.

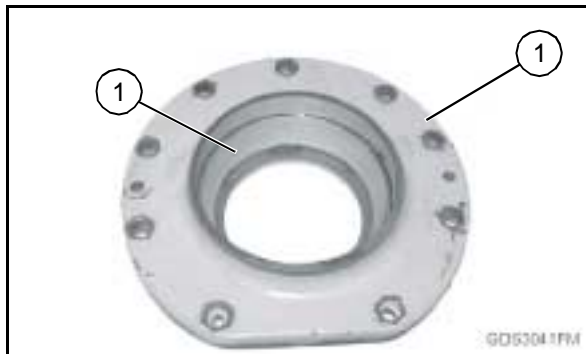

Install bearing cup (1) into bearing housing (2).

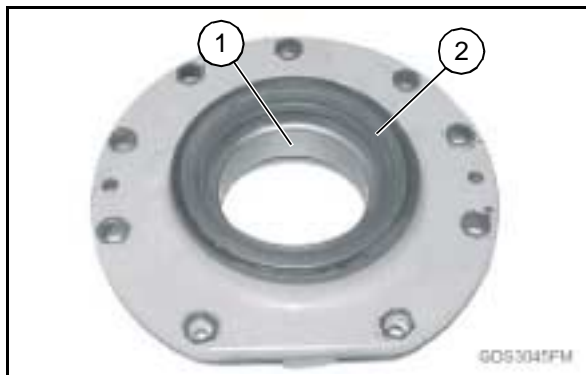

Apply multi-purpose grease to bearing cone (1) and install bearing cone.

Apply cure primer and flexible form-in-place gasket to outer diameter of seal (2) and install seal flush into bearing housing.

▲ CAUTION

Avoid overheating seal when heating bearing cone.

Heat bearing cone to 110°C (230°F). Install assembled bearing housing over input drive shaft ensuring bearing is fully seated.

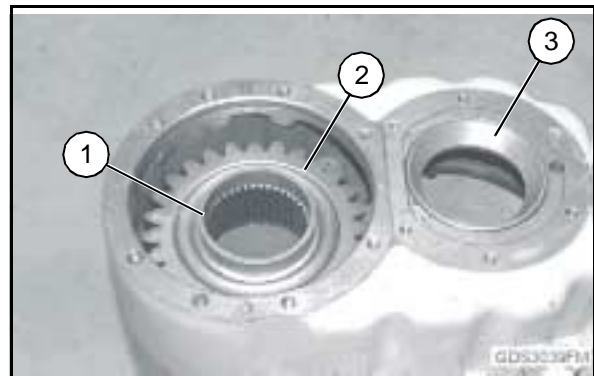

Install spur gear (2) in adapter case with writing up.

Install shim (1) on spur gear.

Install bearing cup (3).

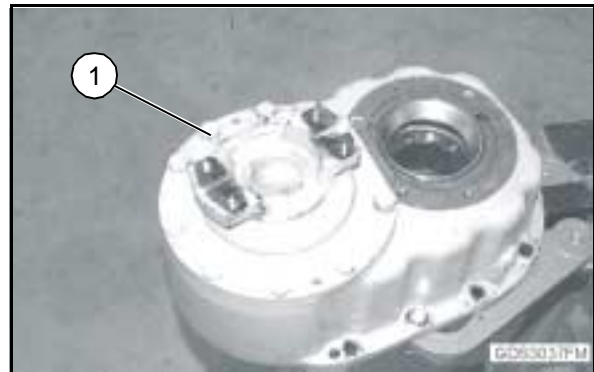

Apply cure primer and form-in-place gasket to mating surfaces of bearing housing.

Install bearing housing and input drive shaft into adapter case.

Apply cure primer and thread lock and sealer to threads of cap screws (1). Install and tighten cap screws.



Disconnect lubrication line from front seal retainer (2).

Remove front seal retainer. Remove outer O-ring from front seal retainer seat. Replace seal (1) using a seal driver.

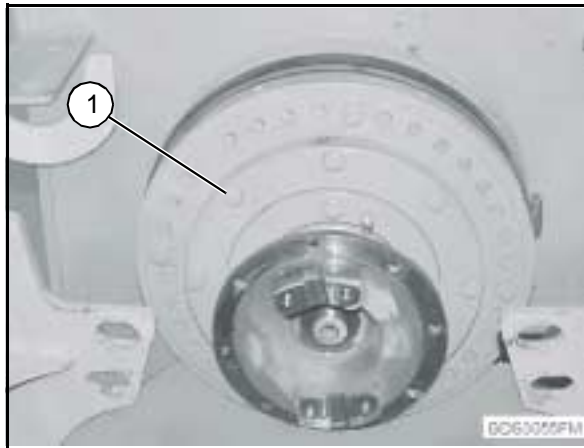

Disconnect lubrication line from rear seal retainer. Disconnect rear bearing retainer from oscillation tube.

Remove drive shaft, rear bearing carrier, and rear yoke as an assembly.

Clean, inspect, and replace parts as necessary.

Install drive shaft, rear bearing carrier, and rear yoke as an assembly. Connect rear bearing carrier to oscillation tube. Connect lubrication line.

Install new outer O-ring in front seal retainer seat. Install front seal retainer. Connect lubrication line.

NOTE: Front and rear yokes must be installed in line with each other.

Install front yoke, washer, and nut. Tighten nut to specification.

Drive Shafts Specification

Drive Shaft Yoke Nut Torque - - - - - 750 Nm (553 lb-ft)

Install park brake disk, caliper, and pads. (See **Park Brake CHAPTER 11, SECTION 1**).

Install transfer case-to-oscillation tube drive shaft and oscillation tube-to-middle axle drive shaft.

Disassemble And Assemble Oscillation Joint-to-Park Brake Drive Shaft

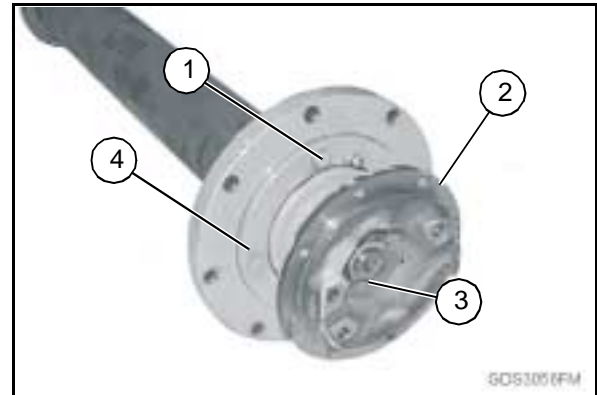

Remove nut and washer (3).

Remove rear yoke (2) using a suitable puller.

Disconnect lubrication line from rear seal retainer (4). Remove rear seal retainer. Remove outer O-ring from rear seal retainer seat.



Install new seal (1) in rear seal retainer (2) using a seal driver.

NOTE: 1. Drive shaft must be installed in the same direction as it was removed. Mark drive shaft ends for ease of assembly.

2. Rear bearing retainer (1) is slip fit over bearing.

Slide rear bearing retainer off of bearing.

- Install strut in 12 ton hydraulic press with oil plug at top. Compress strut until rod extends 100 mm (3.9 in.) from rod guide.
- Install charging valve in barrel. Ensure charging valve is fully open.
- Fill strut until overflowing with Transmax-Z oil. Allow time for oil to settle.
- Compress strut until rod extends 30 mm (1.2 in.) from rod guide. Ensure O-ring is seated firmly on oil plug. Install oil plug.
- Remove strut from hydraulic press.

▲ WARNING

Use ONLY dry nitrogen to charge strut. Other gases can cause oxidation or condensation.

Charge strut with dry nitrogen.

- Connect nitrogen source to charging valve. Charge strut to specification. Close charging valve.

Axle Links, Stabilizers, and Struts Specification

Suspension Strut Nitrogen Charging Pressure: -----
-----3585 kPa (35.9 bar) (520 psi)

- Disconnect nitrogen source. Install valve cap. Install valve guard.

- Install strut in 12 ton hydraulic press. Mark rod at rod guide and 50 mm (2.0 in.) from rod guide. Compress strut to mark. Decompress. Ensure strut expands to original mark. Repeat this step once.
- Remove strut from hydraulic press.

Install clamps on boot.

Replace Bushings

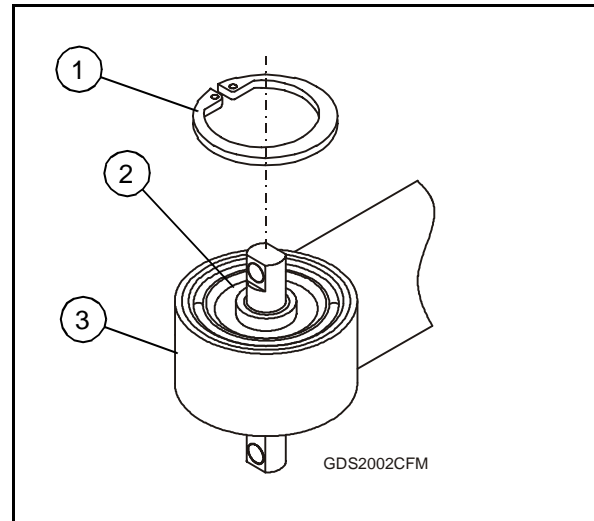

Remove snap ring (1) and press old bushing (2) from bore (3).

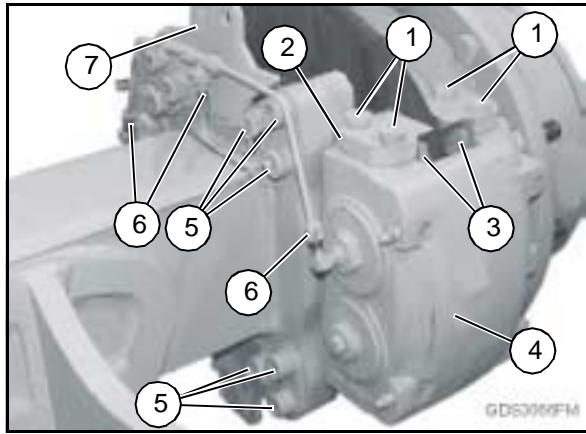

Remove cap screws (1) and retainers (2).

Remove brake pads (3).

Remove brake line nuts (6). Close all openings with caps and plugs.

NOTE: Longer caliper cap screws (5) are used to install support plate (7).

Remove caliper cap screws (5) and remove plate (7).

Remove caliper (4).

Inspect parts for wear or damaged.

Repeat steps (12 - 15) for front brake and caliper.



▲ CAUTION

Approximate weight of hub assembly is 91 kg (200 lb).

Specification

Hub Assembly Weight ----- 91 kg (200 lb)

Attach hoist with tool JDG909 Lifting Brackets.

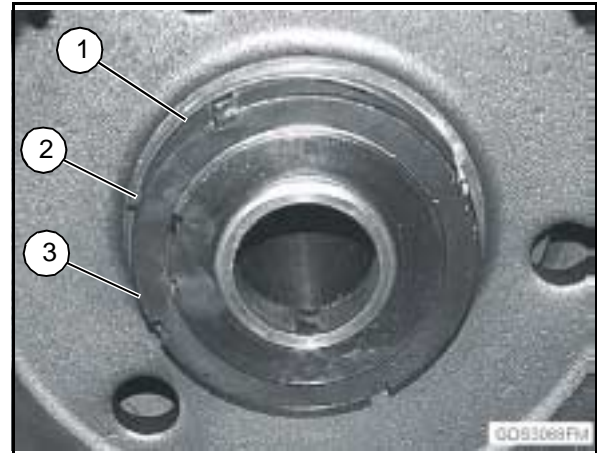

Remove lock ring (1), lock pin (2), and remove nut (3) with hub nut spanner 280173.

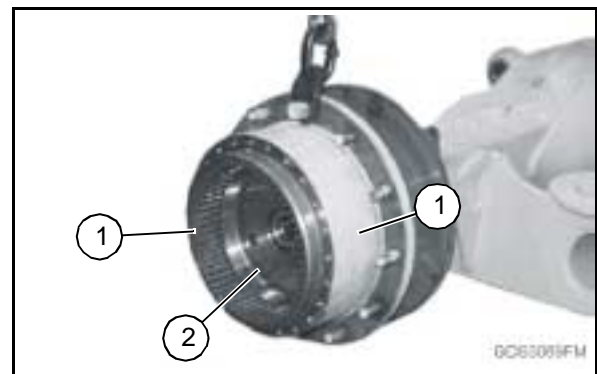

Remove outer ring gear (1) and inner ring gear (2) with bearing.

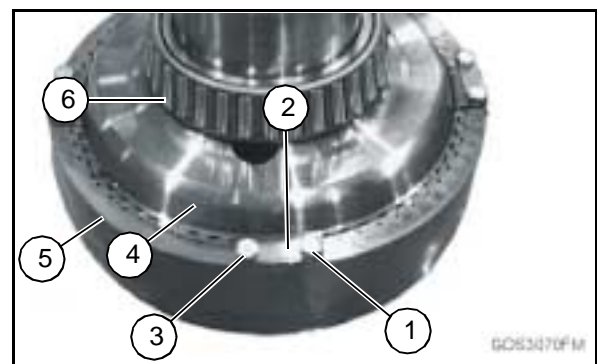

Remove outer wheel bearing (6).

Bend retainer lock (2) tabs.

Remove bolts (3), retainers (1), and locks (2).

Remove Oil Pan and Control Valve

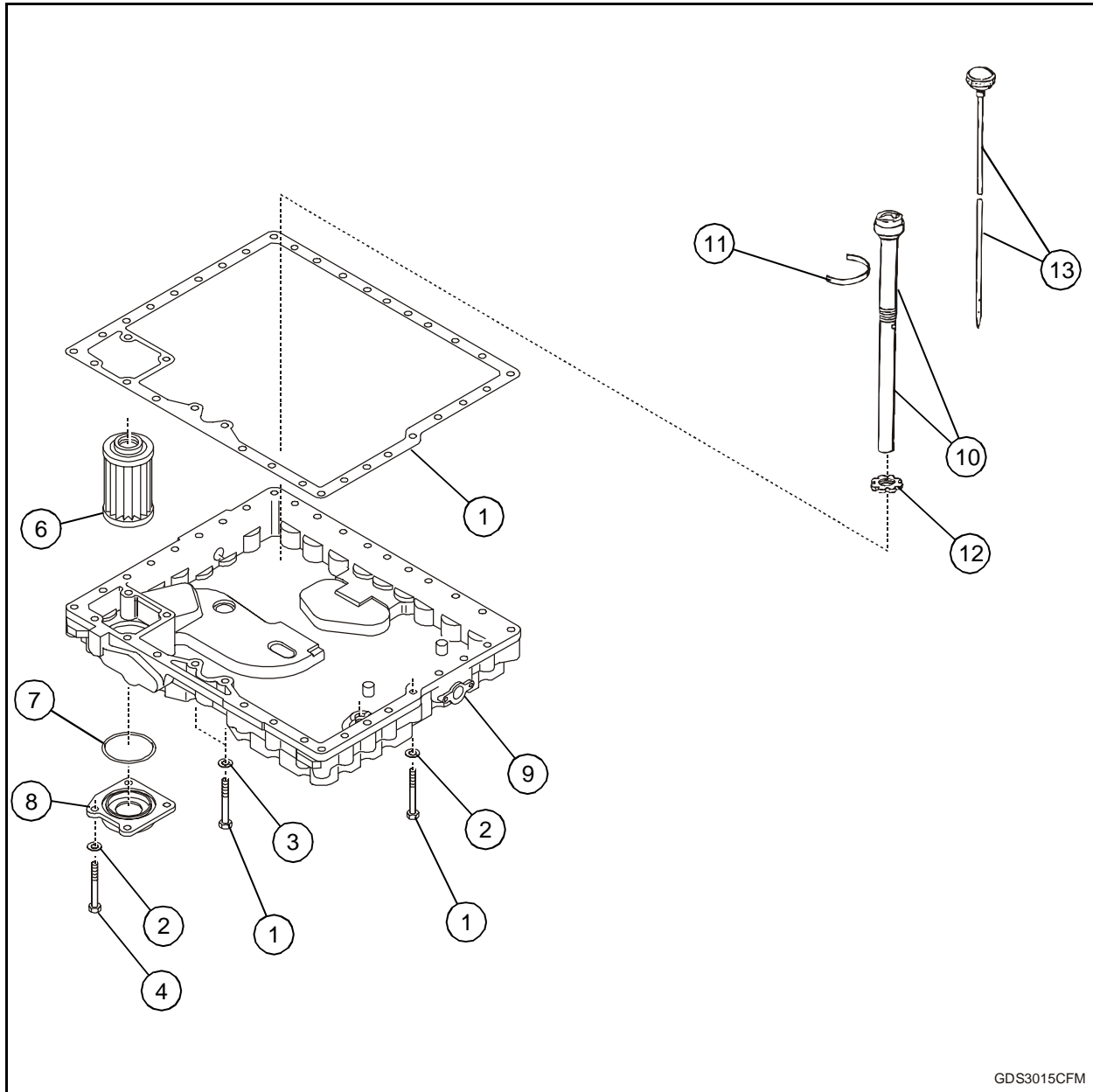

GDS3015CFM

- | | |
|-----------------------------|-----------------------|
| 1. Bolt (33 used). | 8. Filter Cover. |
| 2. Washer (4 used). | 9. Oil Pan. |
| 3. Copper Washer (33 used). | 10. Oil Filler Pipe. |
| 4. Bolt (4 used). | 11. Sealing Tape. |
| 5. Pan Gasket. | 12. Grooved Lock Nut. |
| 6. Filter. | 13. Oil Dipstick. |
| 7. O-Ring. | |

Remove filter cover (8) and filter (6).

Remove oil pan (9) and discard copper washers (3).

NOTE: Oil filler pipe should only be removed when necessary.

Remove oil filler tube (10) if necessary.

Remove, mark and identify order of clutch E plates.

NOTE: During removal do not allow guide pins to drop into transmission.

Remove spring guide centering pin (27).

Remove spring plate holder (11) and spring plate (12).

▲ CAUTION

Wear eye and face protection before using compressed air. Cover transmission oil ports with a cloth for protection from transmission oil when using compressed air.

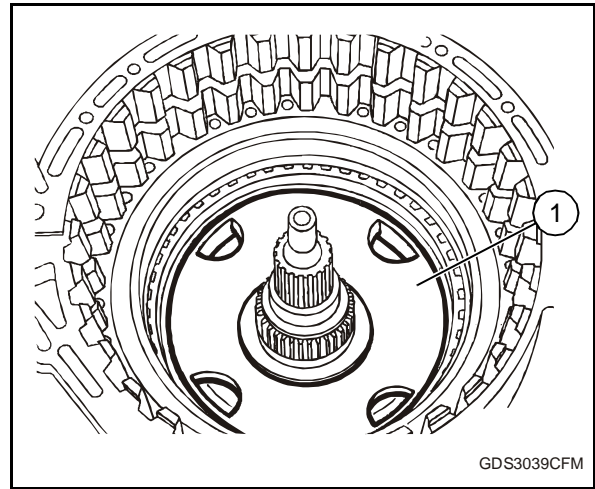

Remove carrier (1).

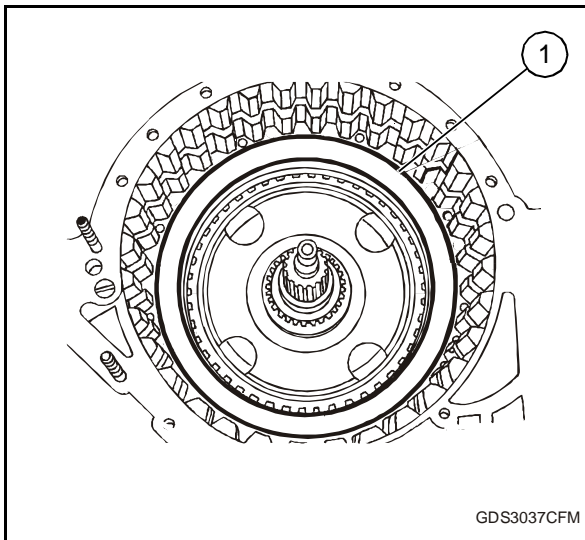

Remove clutch E piston (1).

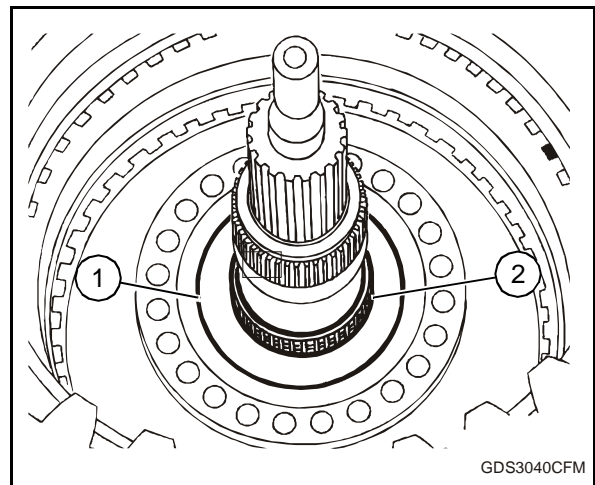

Remove thrust washer (1) and needle bearings (2).

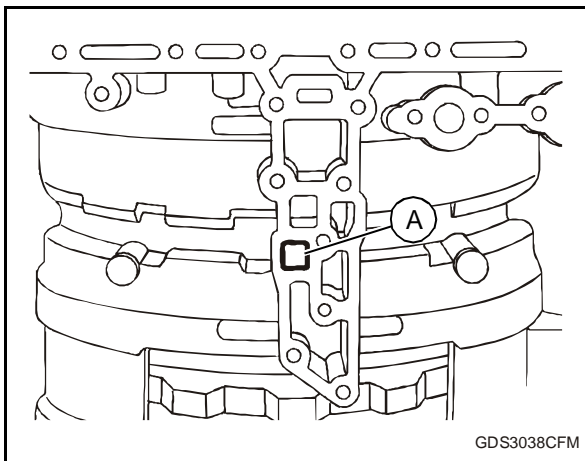

Low air pressure may be applied to port (A) to aid piston removal.

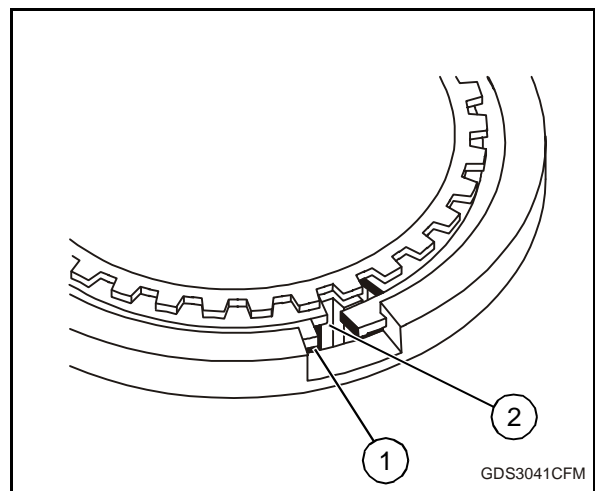

Rotate end of snap rings (1 and 2) to notch opening and remove.

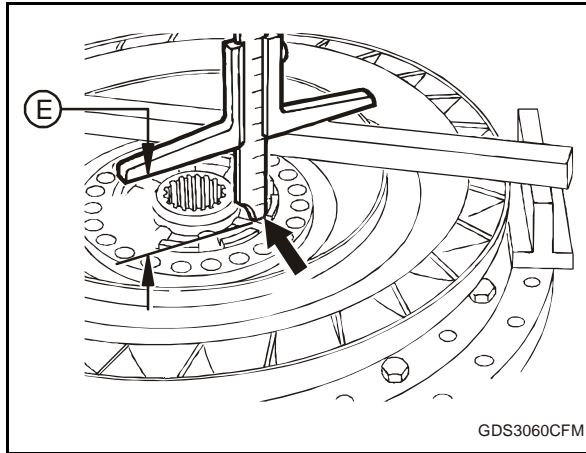

Measure distance from measuring bar to shim (19) contact surface on turbine cover (18). Record as dimension **E**.

Subtract dimension **E** from dimension **D** and record as dimension **F**. **(D-E) = F**

Thrust bearing clearance is 0.1 - 0.3 mm (0.004 - 0.012 in.). Average clearance is 0.2 mm (0.008 in.) dimension H.

Disassemble and Assemble Torque Converter Specification

Stator Thrust Bearing Clearance -----
----- 0.1 - 0.3 mm (0.004 - 0.012 in.)

To determine shim size subtract dimension F from dimension C and record as dimension G. **(C-F) = G**

Subtract average thrust bearing clearance H from dimension G. This will give shim (19) size needed. **(G-H) = shim size**

Place correct shim and washer (20) in turbine cover with chamfer side of washer toward shim.

Apply thin layer of oil to bearing (21) and install with washer (22).

Position stator and bearing (28) on turbine pump cover.

Install O-ring (29).

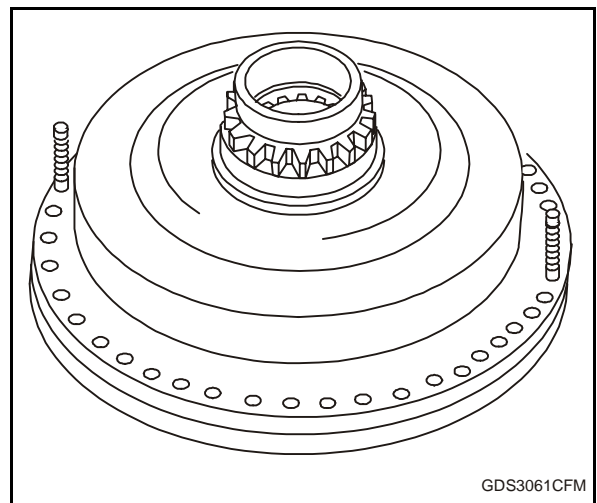

Install two guide pins to assemble circuit cover and pump drive cover.

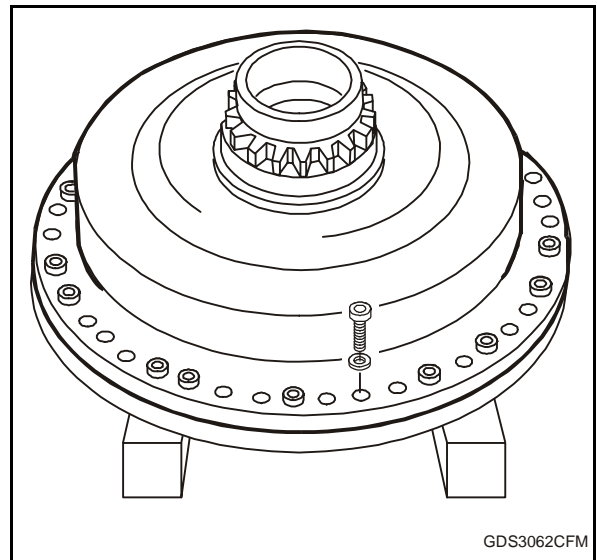

Fit cap screws and tighten.

Disassemble and Assemble Torque Converter Specification

Torque Converter Cap Screws Torque -----
----- -35 Nm (26 lb-ft)

▲ CAUTION

Do not damage shaft face when removing bearings. Use suitable pressure disc on shaft.

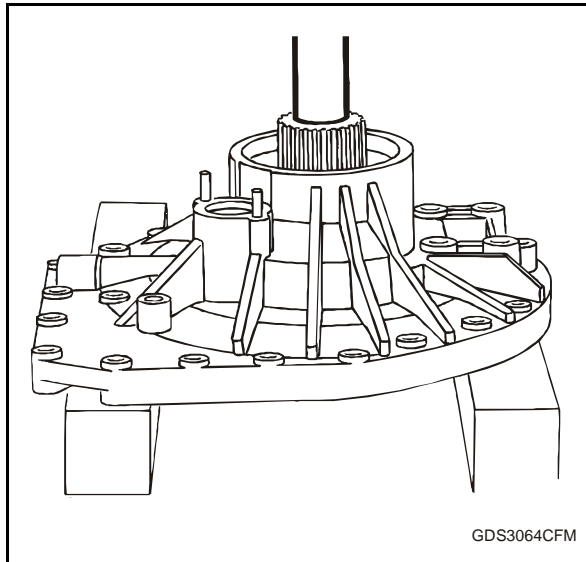

Support output cover. Using press push planetary carrier (10) from output cover.

NOTE:Remove bearing race from output cover only when bearings are replaced.

Remove seal (4) and outer bearing (24).

Remove shims (23).

Remove bushing (22) and bearing (21) with suitable puller.

Inspect and replace bearings and races as needed.

▲ CAUTION

Wear protective gloves components will be hot.

Heat output cover to approximately 85° C (185° F) and remove bearing races at grooves in housing.

Use press to remove bearing from shaft.

Remove thrust ring (8).

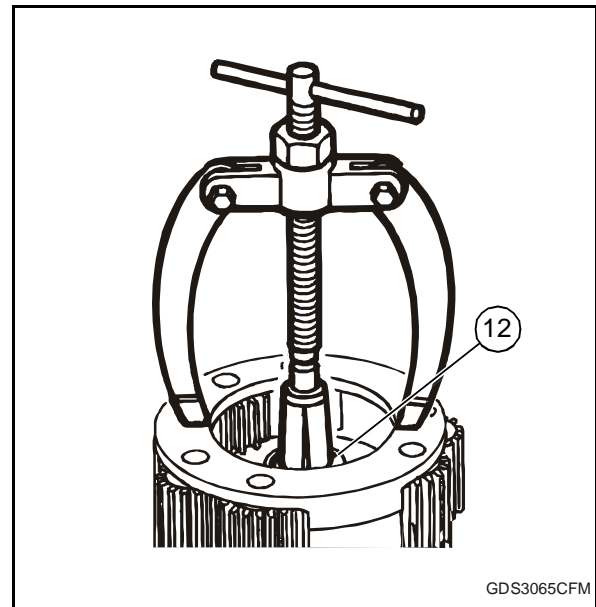

Remove needle bearing (16) with suitable puller.

NOTE:Measure planetary pinion end play before disassembly. Disassembly required only if worn or damaged. Planetary pinions must be replaced as a set.

Measure planetary pinion end play.

Disassemble and Assemble Output Planetary Specification

Carrier Pinion End Play -----
----- 0.5 - 1.2 mm (0.02 - 0.047 in.)

Planetary pinions are replace as a set.

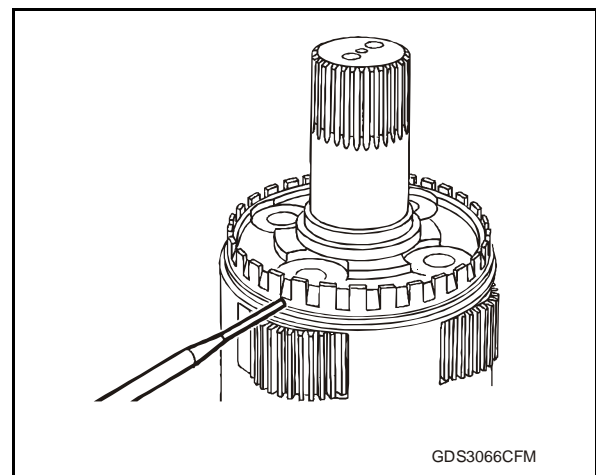

Carefully drive roll pins (15) into center of pinion shafts (11 and 17).

Drive pinion shafts from carrier (10) and remove roll pins.

1. Oil Control Body.
2. Spacer.
3. O-Ring.
4. O-Ring.
5. Spring.
6. Valve.
7. Piston.
8. Piston.
9. Bushing.
10. Washer.
11. Snap Ring.
12. Piston.
13. Spring.
14. Spacer.
15. Retainer Pin (2 used).
16. Piston.
17. Spring.
18. Washer.
19. Snap Ring.
20. Piston.
21. Spring.
22. Spacer.
23. Oil Line.
24. Seal (12 used).
25. Fitting (2 used).
26. Oil Feed Flange.
27. Pump.
28. Cap Screw (2 used).
29. Washer (31 used).
30. Cap Screw (7 used).
31. Intermediate Plate.
32. Thrust Ring.
33. Cap Screw (3 used).
34. Seal Ring (4 used).
35. Bearing.
36. Cap Screw (4 used).
37. Not Used.
38. Cap Screw (4 used).
39. Cap Screw (3 used).
40. Cap Screw (5 used).
41. Retarder Stator Ring.
42. Spring Seat (3 used).
43. Spring (3 used).
44. Spring Guide (3 used).
45. Disc Spring (48 used).
46. Guide Pin (3 used).

▲ CAUTION

Retaining washers are under spring pressure. Take care when removing.

Apply pressure and hold spacer (22) to remove retainer pin (15) and remove spring and valve (20 and 21).

Use 281702 Control Valve Clamp to compress springs (5 and 17).

Remove snap rings (11 and 19) and release spring tension.

Remove Parts (6 - 10) and (16 - 18).

Apply pressure to spacer (14) with screwdriver and remove pin (15).

Remove parts (12 - 14).

Remove spacer and O-ring (2 and 3).

If not removed. Remove intake pipe O-ring (4).



With 281699 Pressure Piece and 281680 Puller, remove bearing (35).

1. Bolt (18 used).
2. Rotor.
3. Seal.
4. Rectangular Ring.
5. Disk Seal.
6. Needle Bearing.
7. Dowel Pin.
8. Hub.
9. Pin.
10. Snap Ring.
11. Retainer Pins (3 used).
12. Snap Ring.
13. Lip Seal.
14. Clutch C Piston.
15. Lip Seal.
16. Clutch Carrier.
17. Seal.
18. Clutch B Piston.
19. Seal.
20. Clutch B End Plate.
21. Clutch B Inner Plate.
22. Pin (9 used).
23. Spring (9 used).
24. Retaining Pin (2 used).
25. Pin (9 used).
26. Clutch B Outer Plate.
27. Clutch B End Plate.
28. Clutch C Inner Plate.
29. Clutch C Outer Plate.
30. Clutch C End Plate.
31. O-Ring.
32. Reverse Gear Housing.
33. Lip Seal.
34. Lip Seal.
35. Clutch A Piston.
36. Spring Plate.
37. Retainer Plate.
38. Snap Ring.
39. Spring Plate.
40. Retainer Plate.
41. Clutch A Inner Plate.
42. Clutch A Outer Plate.
43. Clutch A End Plate.
44. Split Ring.

▲ CAUTION

The Approximate weight of clutch carrier is 25 kg (55 lb).

Remove bolt (1) and rotor (2).

Remove rectangular ring (4) and plate seal (5).

With 281705 Clamping device compress and remove snap ring (12).

Remove clutch C piston (14).

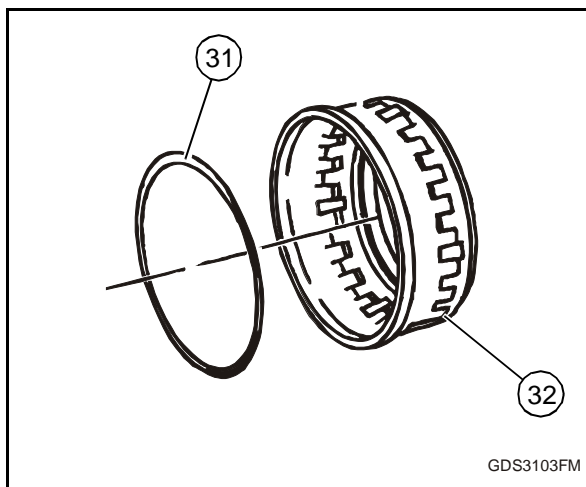

Remove reverse gear housing (32) and O-ring (31).

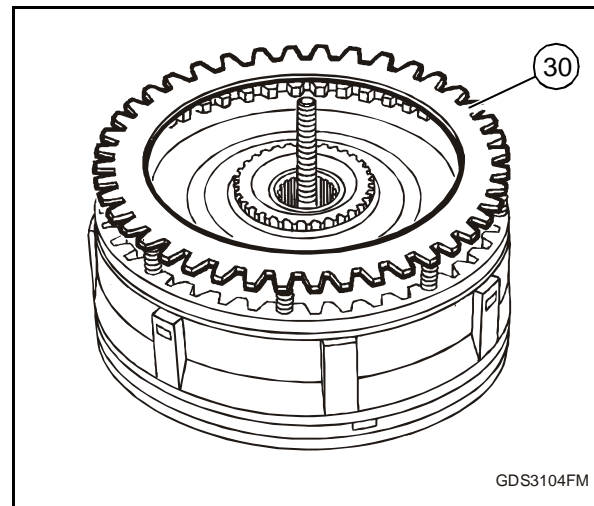

Remove outer plate (30).

Disassemble and Assemble Clutch D

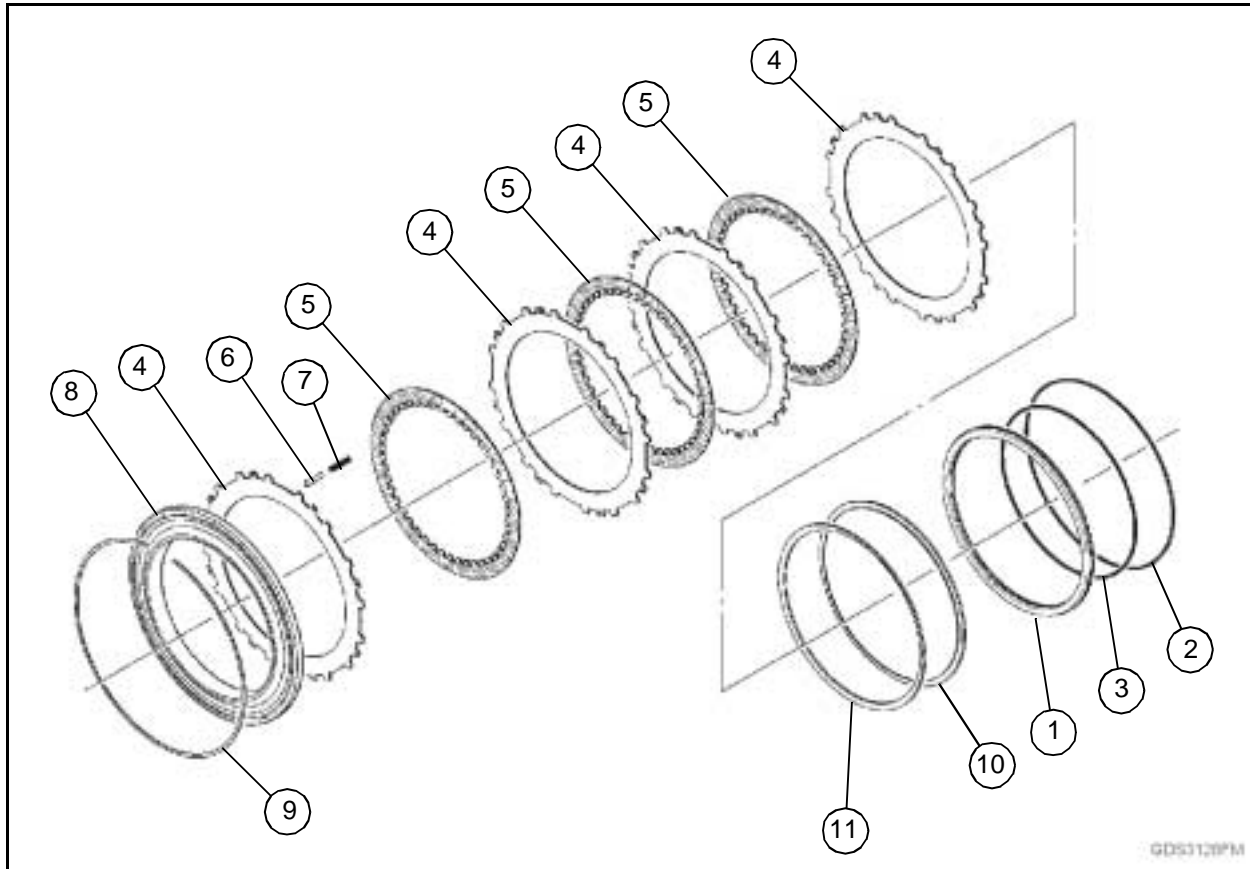

- | | |
|---------------------|--------------------------|
| 1. Clutch D Piston. | 7. Spring (8 used). |
| 2. Seal. | 8. End Plate. |
| 3. Seal. | 9. Snap Ring. |
| 4. Outer Plate. | 10. Spring Plate Holder. |
| 5. Inner Plate. | 11. Spring Plate. |
| 6. Pin (8 used). | |

Apply petroleum jelly to needle bearings (4) and install in sun gear (5).

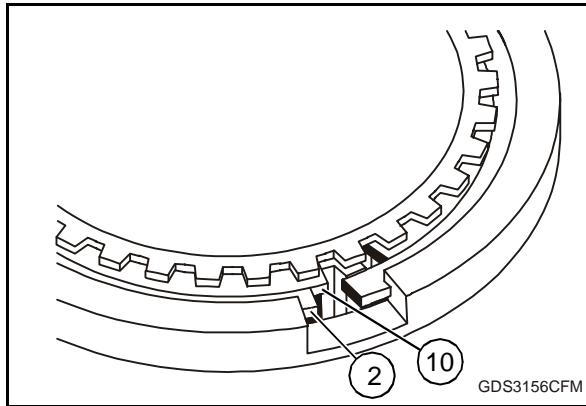

Install sun gear into plate carrier (3) and install snap rings (2 and 10) with ends positioned as shown.

Install thrust washer (1) on plate carrier.

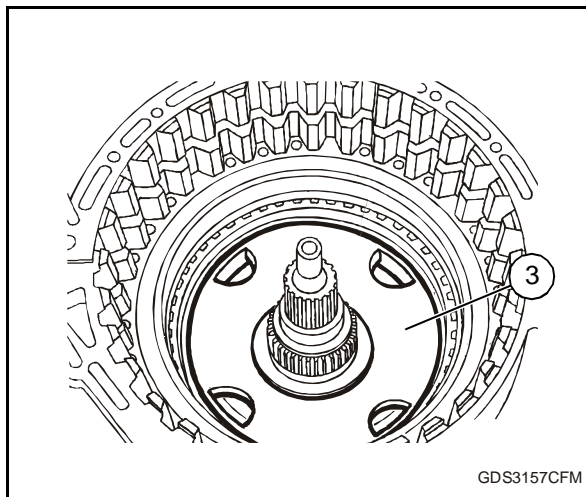

Install plate carrier and ensure needle bearings remain in position. Make sure carrier makes contact with thrust washer.

Apply thin layer of petroleum jelly install thrust washer (3).

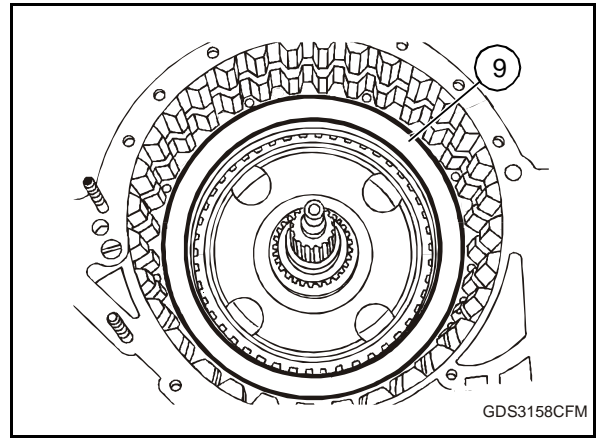

Install lip seal rings (7 and 8) with lip towards pressure side.

Install clutch E piston (9). Piston must make contact at bottom of piston bore.

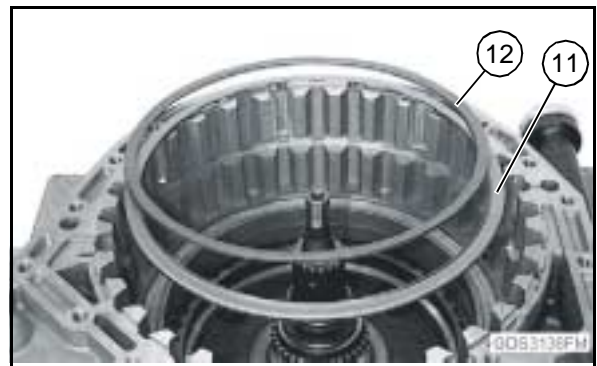

Install spring plate holder (11) and spring plate (12).

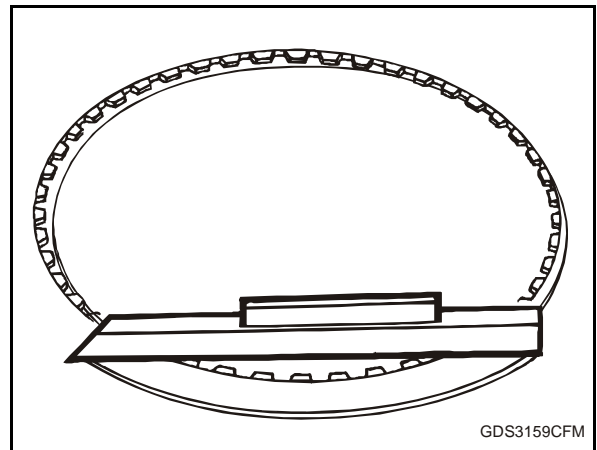

Clutch plates must be straight and flat.

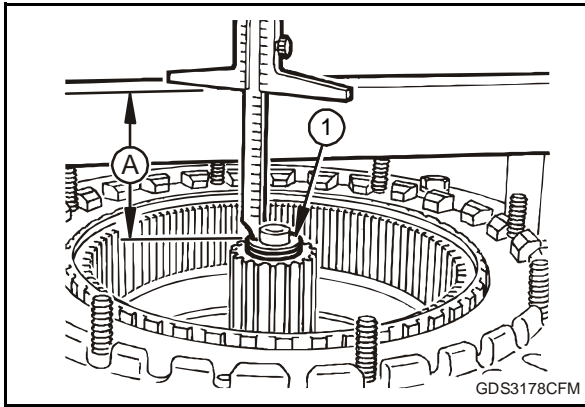

With intermediate housing secured, use measuring blocks and measure sun gear height with needle bearing and thrust washer (1) in place. Record as dimension (A).

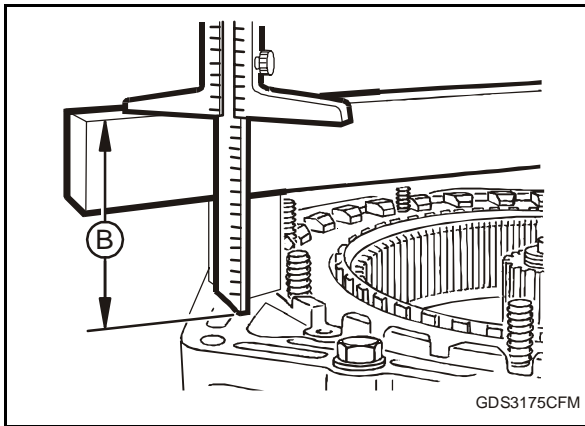

With measuring blocks measure intermediate housing without gasket at several locations and calculate average. Record as dimension (B).

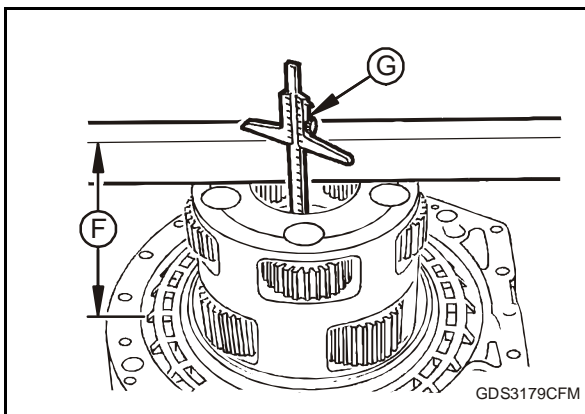

Subtract Dimension (A) from dimension (B). Record as dimension (C). $(B-A) = C$

Position gasket on output housing and measure output planetary carrier height at several locations. Calculate average height and record as dimension (F).

With measuring block on planetary carrier measure thrust washer surface height and record as dimension (G).

Calculate correct shim size (H).

Subtract dimension (F) from (G) and note as dimension (D). $(G-F) = F$

Subtract dimension (C) from dimension (D) and note as dimension (E). $(D-C) = E$.

Subtract sun gear end play specification average 0.5 mm (0.020 in.) from dimension (E). Record as shim size (H). $(0.5 \text{ mm (0.002 in.)} - E) = H$ shim size.

Output Planetary and Clutch Element Specification

Sun Gear End Play -- 0.4 - 0.6 mm (0.016 - 0.024 in.)

Use combination of two shim sizes for end play adjustment.

Install needle bearing and shims on sun gear.

Remove three cap screws holding intermediate housing and install gasket.

Attached DFT1231 Output Assembly Lifting Bracket to output shaft.

Using guide pins lower output planetary cover and guiding speed sensor harness through housing. Planetary gears must align and mesh with sun gear.

Tighten cap screws in a side to side cross pattern to specification.

Output Planetary and Clutch Element Specification

Output Planetary Cover Torque -----46 Nm (34 lb-ft)

Install flange (9) and retainer plate (11) with bevel edge out. Tighten cap screw.

Output Planetary and Clutch Element Specification

Output Yoke Torque ----- 60 Nm (44 lb-ft)

Install new lock plate (13) with 281683 Punch.

CHAPTER 3. TRANSMISSION

SECTION 4. HYDRAULIC SYSTEM

REMOVE AND INSTALL TRANSMISSION OIL-TO-AIR COOLER

Turn battery disconnect switch off.

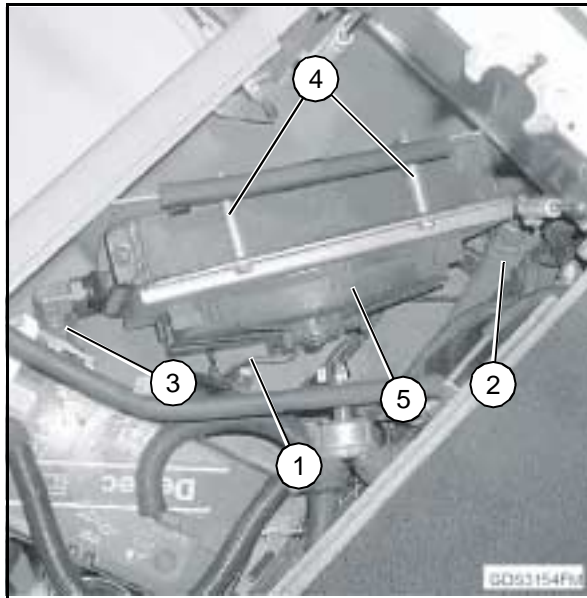

Disconnect fan wire connector (1).

Disconnect oil lines (2 and 3) from cooler. Close all openings using caps and plugs.

Remove bolts, spacers, and nuts (4).

Remove fan and shroud (5) and then remove cooler.

Repair or replace as required.

Install cooler and shroud using cap screws, spacers, and nuts.

Connect oil lines and wire connector.

Remove and Install Transmission Oil-to-Water Cooler

Turn battery disconnect off.

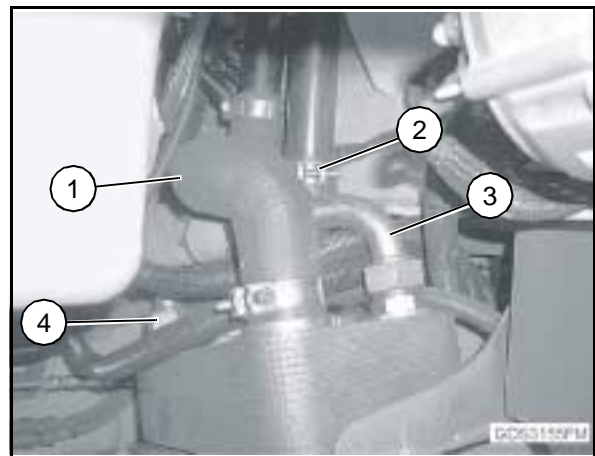

Drain engine coolant.

Disconnect coolant hoses (1 and 2).

Disconnect oil lines (3 and 4). Close all openings using caps and plugs.

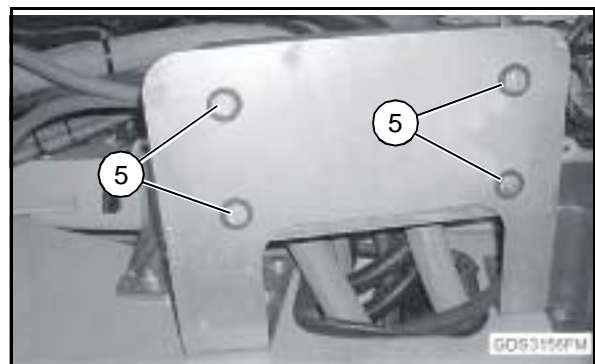

Remove bolts (5) and remove cooler.

Repair or replace as required.

Install cooler using bolts.

Connect oil lines and coolant lines.

Fill engine with coolant.

FLYWHEEL

Remove and Install Flywheel

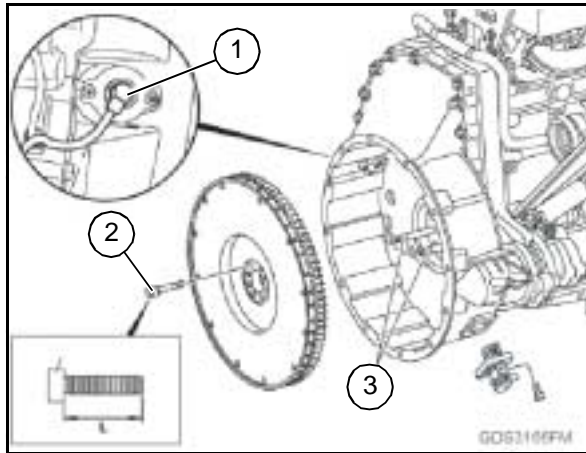

Pull crankshaft position sensor (1) out from timing case approximately 8 mm (0.3 in.).

Attach cranking device to timing case (See “Install Cranking Device” on page 165).

Unscrew flywheel bolts (2).

Screw centering drifts (3) into two oppositethreaded holes.

Remove cranking device.

Remove the flywheel over the centering drifts.

Measure flywheel bolts. If the bolts are to long or to short, replace the bolts with new bolts.

Inspect the flywheel for size, scorches, scores or cracks. If out of specification, replace the flywheel.

Flywheel Bolts Specification

- M14 New----- 60mm (2.36")
- M14 Shank Length Max. ----- 61mm (2.4")
- Flywheel Thickness between friction surface and mounting flange ----- 55 mm (2.2")
- Flywheel Bolt torques first stage - - - -50Nm (36.9 lb-ft)
- Flywheel Bolt torques second stage- 125Nm (92 lb.-ft.)
- Flywheel Bolt torques third stage ----- 90°

Inspep flywheel flange for signs of wear and traces of hollowing caused by seal.

Inspect ring gear for wear.

Install in reverse order.

Replace Ring Gear

▲ WARNING

Wear protective gloves, clothing and eye protection. Risk of injury to eyes and skin from handling hot or glowing objects.

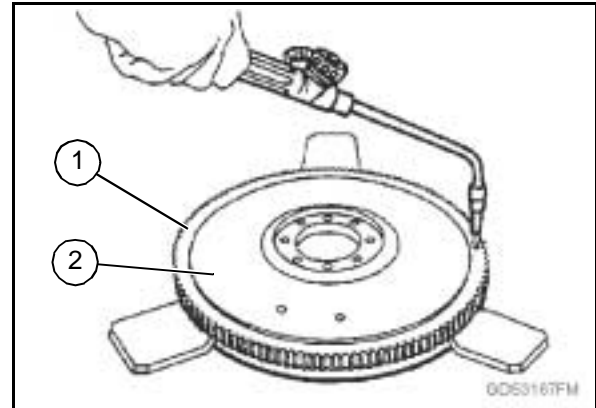

Use a welding torch to rapidly heat ring gear.

Press the ring gear (1) off the flywheel (2).

Measure the flywheel dia. for mounting the starter ring gear.

Measure ring gear inner.

Heat new starter ring gear.

NOTE:Temperature is reached once the ring gear has a bright yellow annealing colour.

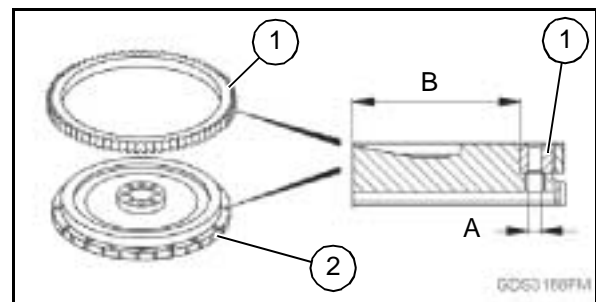

Press the ring gear onto the flywheel as far as the contact surface.

Drill holes “A” for mounting the clutch pressure plate in the ring gear and tap thread M14 x 1.5.

Install flywheel.

Remove Oil Pump

Remove vibration damper. (See “Remove and Install Belt Pulley/Vibration Damper” on page 165).

Remove oil pan. (See “Removing Oil Pan” on page 168).

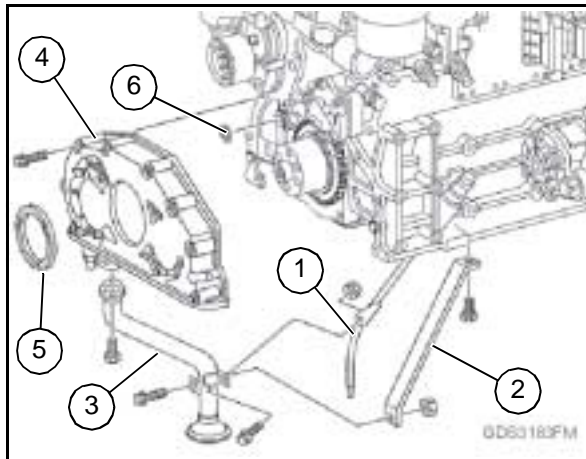

Take off dipstick tube (1) and bracket (2) at suction pipe (3).

Take off suction pipe (3).

Take off oil pump (4).

Remove radial seal (5).

Remove O-ring (6).

Inspect contact surface of crankshaft for signs of scoring or rubbing.

NOTE: If wear exists, a radial seal with race has been available from about 10/1996 for repairs. Use a drift to replace the radial seal as far as the stop.

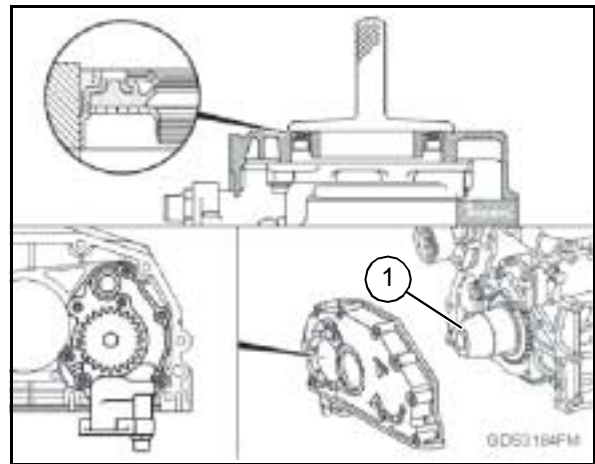

Position guide sleeve (1) onto the crankshaft flange and install oil pump.

Install in reverse order.

Tighten bolts to specification.

Oil Pump Bolt Specification

Oil pump to crankcase - - - - - 25 Nm (18.4391 lb. ft.)

Intake pump to oil pump - - - - - 25 Nm (18.4391 lb. ft.)

Bracket of oil pump suction pipe to crankcase - - - - -
- - - - - 50 Nm (36.878 lb. ft.)

BLEED ENGINE OIL CIRCUIT AFTER MAJOR OVERHAUL

▲ CAUTION

After major overhaul of the engine, the oil circuit must be bled to ensure proper lubrication when the engine is first started.

Fill a container, that can be pressurized using a hand pump, with clean engine oil.

Remove valve cover. (See “Removing And Installing Cylinder Head Cover” on page 201).

Remove plug and seal from oil filter housing.

Install fitting. Adapt pump to fitting.

Pressurize container to approximately 300 kPa (3 bar) (43 psi). Open shut-off valve on container and observe rocker arms. Allow oil to flow until oil from rocker arms is free of bubbles. Maintain at least 150 kPa (1.5 bar) (22 psi) in container during bleed procedure.

CLICK HERE TO **DOWNLOAD** THE COMPLETE MANUAL

- Thank you very much for reading the preview of the manual.
- You can download the complete manual from: www.heydownloads.com by clicking the link below



- Please note: If there is no response to CLICKING the link, please download this PDF first and then click on it.

CLICK HERE TO **DOWNLOAD** THE COMPLETE MANUAL

CHAPTER 4. ENGINE

SECTION 4. CYLINDER BLOCK, LINERS, PISTONS AND CONNECTING RODS

LINER, PISTON AND ROD ANALYSIS

Scuffed or Scored Pistons

- Overheating.
- Overfueling.
- Insufficient lubrication.
- Insufficient cooling.
- Improper piston-to-liner clearance.
- Coolant leakage into crankcase.
- Misaligned or bent connecting rod.
- Improperly installed piston.
- Low oil level.
- Improper operation.
- Incorrect connecting rod bearing clearance.
- Carbon build-up in ring groove.
- Improper engine break-in.
- Worn piston.
- Contaminated oil.
- Distorted cylinder liner.
- Plugged piston cooling orifice.
- Ingestion of dust through air intake.

Worn or Broken Compression Rings

- Insufficient lubrication.
- Insufficient cooling.
- Improper ring installation.
- Improper timing.
- Abrasives in combustion chamber.

Clogged Oil Control Ring

- Improper oil.
- Excessive blow-by.
- Contaminated oil.
- Improper periodic service.
- Low operating temperature.

Stuck Rings

- Improper oil classification.
- Improper periodic service.
- Poor operating conditions.
- Coolant leakage into crankcase.
- Excessive cylinder liner taper.

Mottled, Grayish or Pitted Compression Rings

- Internal coolant leaks.

Dull Satin Finish and Fine Vertical Scratches on Rings

- Dirt and abrasives in air intake system.

Piston Pin and Snap Ring Failure

- Misaligned connecting rod.
- Excessive crankshaft end play.
- Incorrect snap rings.

Broken Connecting Rod

- Inadequate piston-to-liner clearance.
- Worn connecting rod bearing.
- Distorted cylinder line.
- Piston pin failure.

Cylinder Liner Wear and Distortion

- Incorrectly installed compression rings.
- Insufficient lubrication.
- Uneven cooling around liner.
- Inadequate piston-to-liner clearance.
- Liner bore damage.

Warped Cylinder Block

- Insufficient cooling.

▲ WARNING

Do not use gasoline, kerosene, or commercial solvent to clean liners. Solvents will not remove all the abrasives from liner walls.

Thoroughly clean liner ID with a 50 percent solution of hot water and liquid detergent.

Rinse thoroughly and wipe dry with a clean rag.

Swab out liner as many times as necessary with clean 10W engine oil.

Clean liner until a white rag shows no discoloration.

Clean cylinder walls with white spirits and remove masking on crankcase contact surface.

Re-assemble in reverse order.

Attach lifting device to cylinder head.

Remove cylinder head cap screws (2), cylinder head (3) and cylinder head gasket (4).

Clean threaded, oil and coolant holes in crankcase.

Measure length of shank of cylinder head cap screws, if out of specification, replace.

Inspect cylinder head for cracks and damage.

Inspect cylinder head for flatness of contact surface with knife-edge straightedge. Face cylinder head and crankcase if out of specification.

Install Cylinder Head

Use tap and die for head bolt holes and bolts to clean up threads in cylinder block and cap screws.

Install centring sleeves into cylinder block.

Install new head gasket over centring sleeves.

Install cylinder head onto crankcase.

▲ WARNING

Cylinder head cap screws are stretched when tightened to specification. Cap screws are usable up to the maximum shank length specification measured from the end of cap screw to the bottom of cap screw head. If any cap screw is longer than the specification, replace all cap screws for that cylinder head.

Cylinder Head Specification

- Cap Screw Shank Length -----
----- 149.0 mm (5.866 in.) new
 - Cap Screw Shank Length -----
----- 151.0 mm (5.945 in.) max.
 - Permissible flatness over entire length -----
----- 0.05 mm (0.002 in.)
 - Permissible flatness over a length of 150 mm (5.906 in.) -----
----- 0.02 mm (0.0008 in.)
 - Cylinder head cap screw to crankcase torque 1st stage -----
----- 20 Nm (14.751 lb. ft.)
 - Cylinder head cap screw to crankcase torque 2nd stage -----
70 Nm (51.630 lb. ft.)
 - Cylinder head cap screw to crankcase torque 3rd stage -----
----- 170 Nm (125.386 lb. ft.)
 - Cylinder head cap screw to crankcase torque 4th stage -----
----- 280 Nm (206.517 lb. ft.)
 - Cylinder head cap screw to crankcase torque 5th stage -----
-----90°
 - Cylinder head cap screw to crankcase torque 6th stage -----
-----90°
- Oil threads of cap screws with clean engine oil and install cylinder head cap screws (6).

Valve Guide Specification

- Valve Guides ID machined (Dim. (3))
-----8.000 - 8.022 mm (0.315 - 0.316 in.)
- Standard OD (Dim. (5))
----- 13.028 - 13.046 mm (0.5129 - 0.5136 in.)
- 0.20 mm Oversize OD (Dim. (5))
----- 13.228 - 13.246 mm (0.5208 - 0.5215 in.)
- Projection of valve guide (Dim. (2)) inlet -----
-----14.1 - 14.5 mm (0.5551 - 0.5709 in.)
- Projection of valve guide (Dim. (2)) exhaust -----
-----17.6 - 18.0 mm (0.6929 - 0.7087 in.)
- Valve guide length ----- 60 mm (2.3622 in.)
- Valve guide overlap in cylinder head -----
-----0.010 - 0.046 mm (0.0004 - 0.0018 in.)

Remove Valve Guides

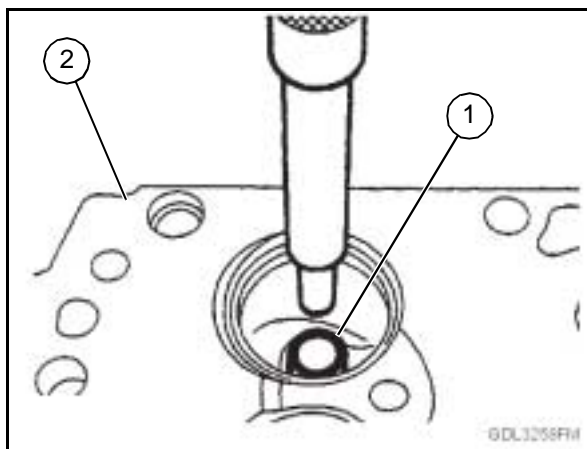

If valve guide(s) (1) need to be replaced, knock out old valve guide from combustion side of head (2) towards top of cylinder head.

Bore out cylinder head valve guide bore to specification for guide size being replaced.

NOTE:Take note of overlap size between valve guide O.D. and cylinder head valve guide bore.

▲ WARNING

Wear heat-protective clothing and full eye protection. Ensure adequate ventilation. Risk of injury from handling liquid nitrogen or from contact with severely supercooled objects and suffocation from inhaling nitrogen gas.

Place valve guide into supercooling box and pour in liquid nitrogen.

Remove valve guide from cooling box with pliers and press into heated cylinder head with the drift and the spacer sleeve.

Ream out valve guide for proper valve stem-to-guide clearance.

Clean valve guides and install valves.

Clean and Inspect Valve Seats

Use an electric hand drill with D17024BR End Brush or equivalent brush to remove all carbon on valve seats.

Check seats for cracks, pits, or excessive wear.

Check entire combustion face for rust, scoring, pitting, or cracks.

Measure Valve Seats

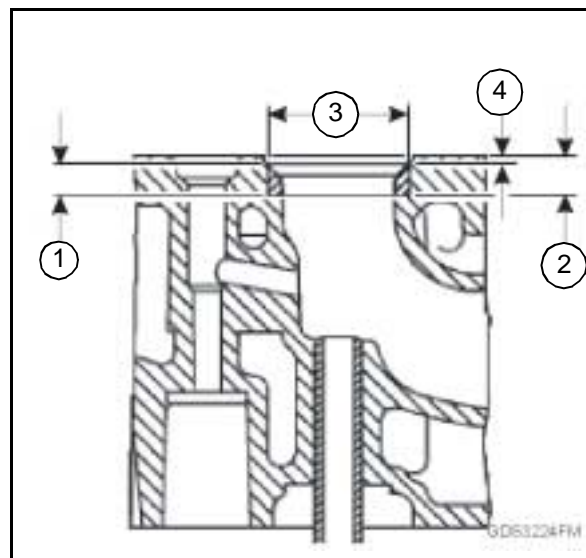

1. Valve Seat Width.
2. Valve Seat Recess in Cylinder Head.
3. Valve Seat Diameter.
4. Distance between cylinder head contact surface and face of valve seat ring.

Measure valve seats for proper specifications listed below.

Intake and Exhaust Valve Specification

- Intake Valve Seat Width dim. (1) -----
-----7.60 - 7.7 mm (0.2992 - 0.3031 in.)
- Exhaust Valve Seat Width dim. (1) -----
----- 8.0 - 8.1 mm (0.315 - 0.319 in.)
- Intake Valve Seat-to-Cylinder Head Recess dim. (2) - -
----- 11.4 - 11.6 mm (0.4488 - 0.4567 in.)
- Exhaust Valve Seat-to-Cylinder Head Recess dim. (2)-
-----11.4 - 11.6 mm (0.4488 - 0.4567 in.)

CHAPTER 4. ENGINE

SECTION 10. TURBOCHARGER

TURBOCHARGER

Remove and Install Turbocharger

▲ CAUTION

Prevent possible injury from hot exhaust pipes and turbocharger. Exhaust pipes and turbocharger can be hot enough to cause burns. Wait for exhaust pipes and turbocharger to cool before working on the machine.

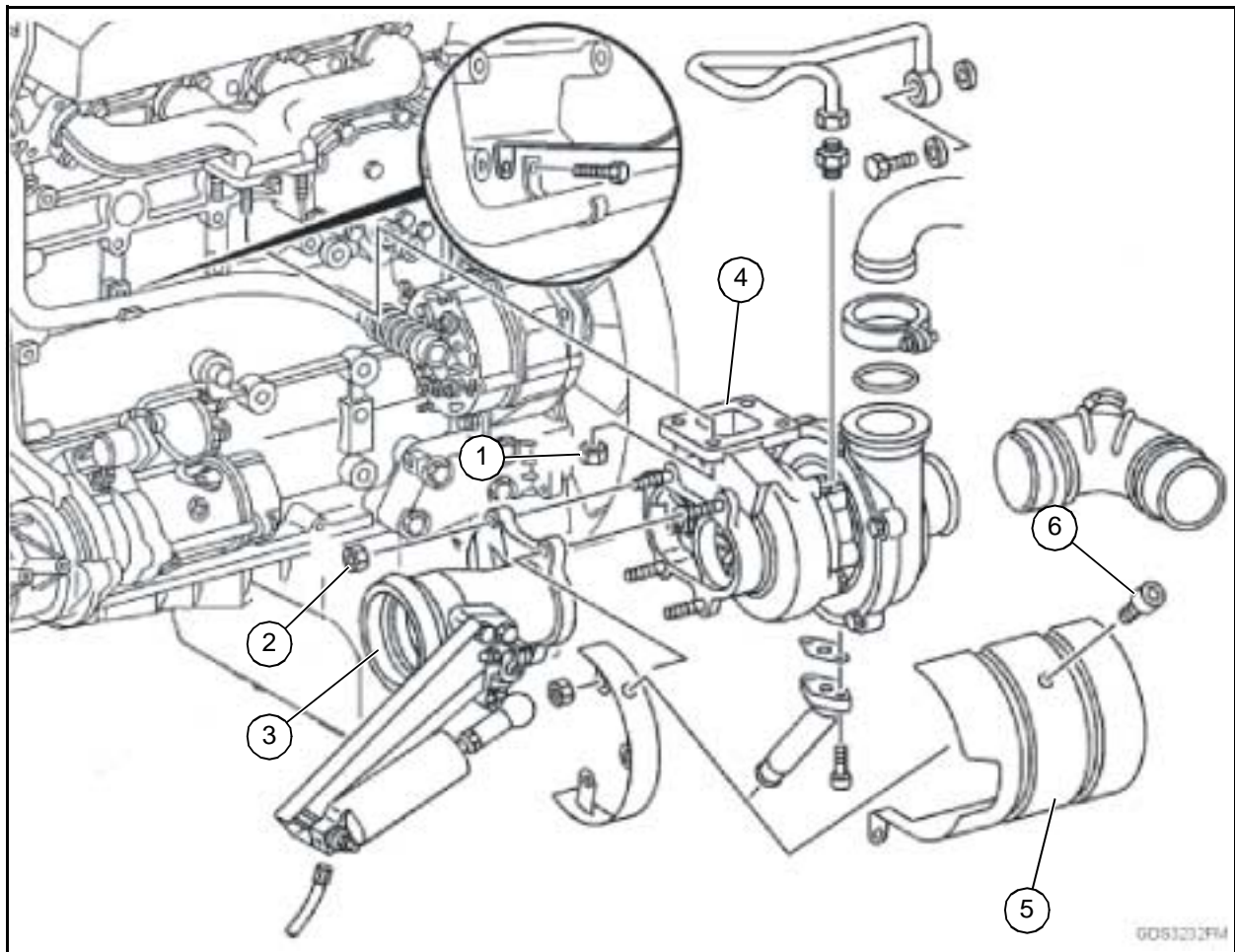

1. Nut.
2. Nut.
3. Exhaust Brake Flap Assembly.
4. Turbocharger.
5. Heat Shield.
6. Cap Screw.

CHAPTER 4. ENGINE

SECTION 12. THERMOSTATS, HOUSING AND WATER PIPING

THERMOSTATS AND HOUSING

Remove And Install Thermostats And Housing

Drain coolant from engine. (See Change Engine Coolant In Operator's Manual, CHAPTER 11, SECTION 2).

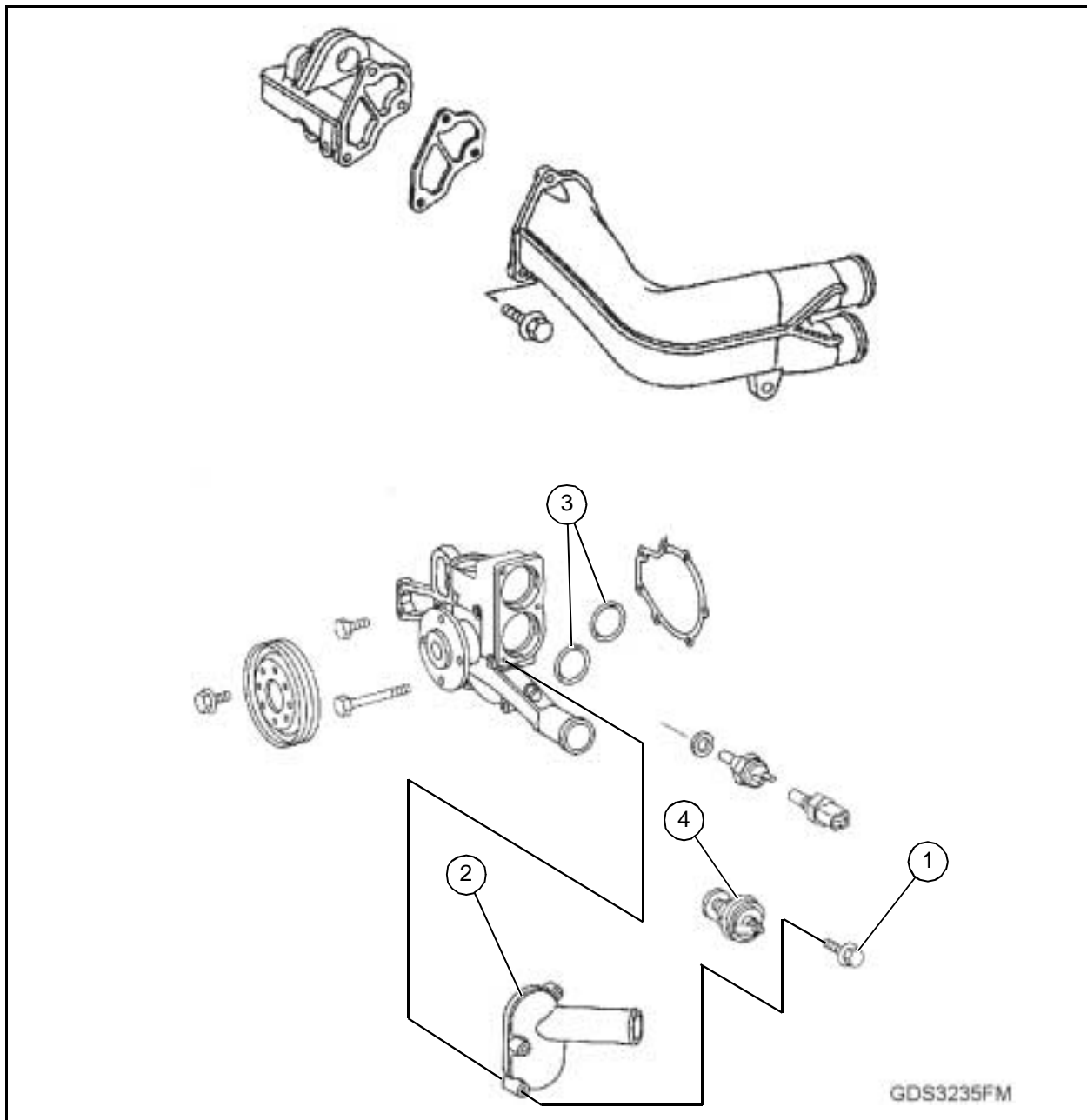

Disconnect upper radiator hose coolant pipe.

Remove bolts (1).

Remove coolant pipe (2).

Remove the O-Rings (3).

Remove the thermostats (4).

CHAPTER 5. ENGINE AUXILIARY SYSTEM

SECTION 4. ENGINE MOUNTING

ENGINE AND TRANSMISSION MOUNTINGS

Remove and Install Engine And Transmission Rubber Mountings

Engine

Right Side Engine Mounts

▲ CAUTION

The approximate weight of engine and transmission is 1179 kg (2600 lb).

Tilt Cab (**Operator's Manual, CHAPTER 7, SECTION 1**).

Lift the engine and transmission just enough to relieve pressure on mounts. (**See Remove Engine CHAPTER 4, SECTION 1**).

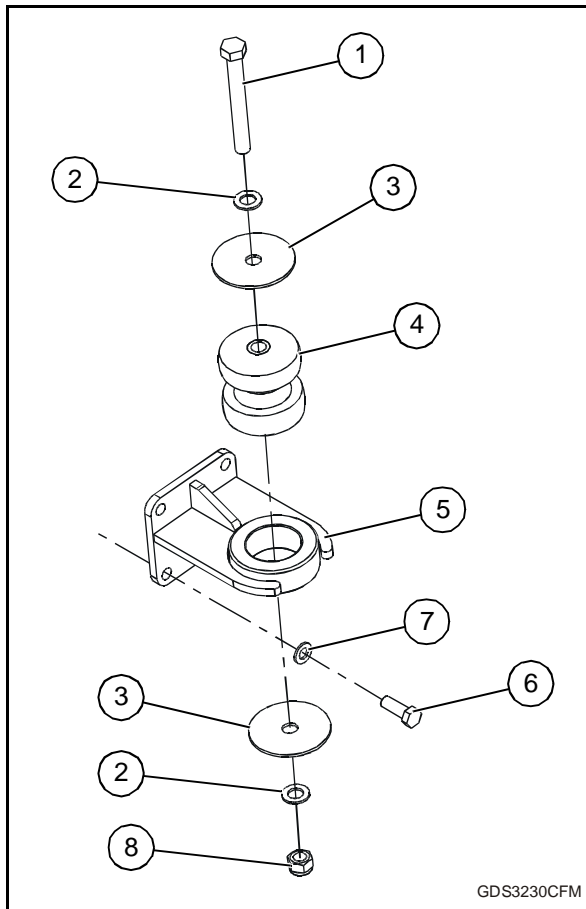

- 1. Cap Screw
- 2. Washer (2 used)
- 3. Retaining Washer

- 4. Rubber Cushion
- 5. Right Engine Mount Bracket
- 6. Cap Screw (4 used)
- 7. Washer (4 used)
- 8. Nut

Remove engine mounting cap screw (1), washers (2), retaining washer (3) and nut (8).

Remove rubber cushions (4).

Install rubber cushions. Lower engine onto cushions.

Install mounting cap screw, washers, retaining washer and nut. Tighten to specification.

Remove and Install Engine and Transmission Rubber Mounts Specification

- Engine and Transmission Weight- - - 1179 kg (2600 lb)
- Engine Mount Bracket Cap Screw Torque - - - - - 280 Nm (207 lb-ft)
- Engine Mount Bracket Socket Head Cap Screw Torque - - - - - 140 Nm (103 lb-ft)
- Engine Mount Cap Screw Torque - - - - - 435 Nm (320 lb-ft)

Lower cab. (**See Tilt Cab in Operator's Manual, CHAPTER 7, SECTION 1**).

Left Side Engine Mounts

See Right Side Engine Mounting.

Transmission Rubber Mounts

▲ CAUTION

The approximate weight of engine and transmission is 1179 kg (2600 lb).

Lift the engine and transmission just enough to relieve pressure on mounts. (**See Remove Engine CHAPTER 4, SECTION 1**).

Install and Align Transfer Case

▲ CAUTION

Machine must be steered to straighten articulation joint when installing and aligning transfer case. Ensure that articulation safety lock bar is installed.

Position transfer case and lift into frame.

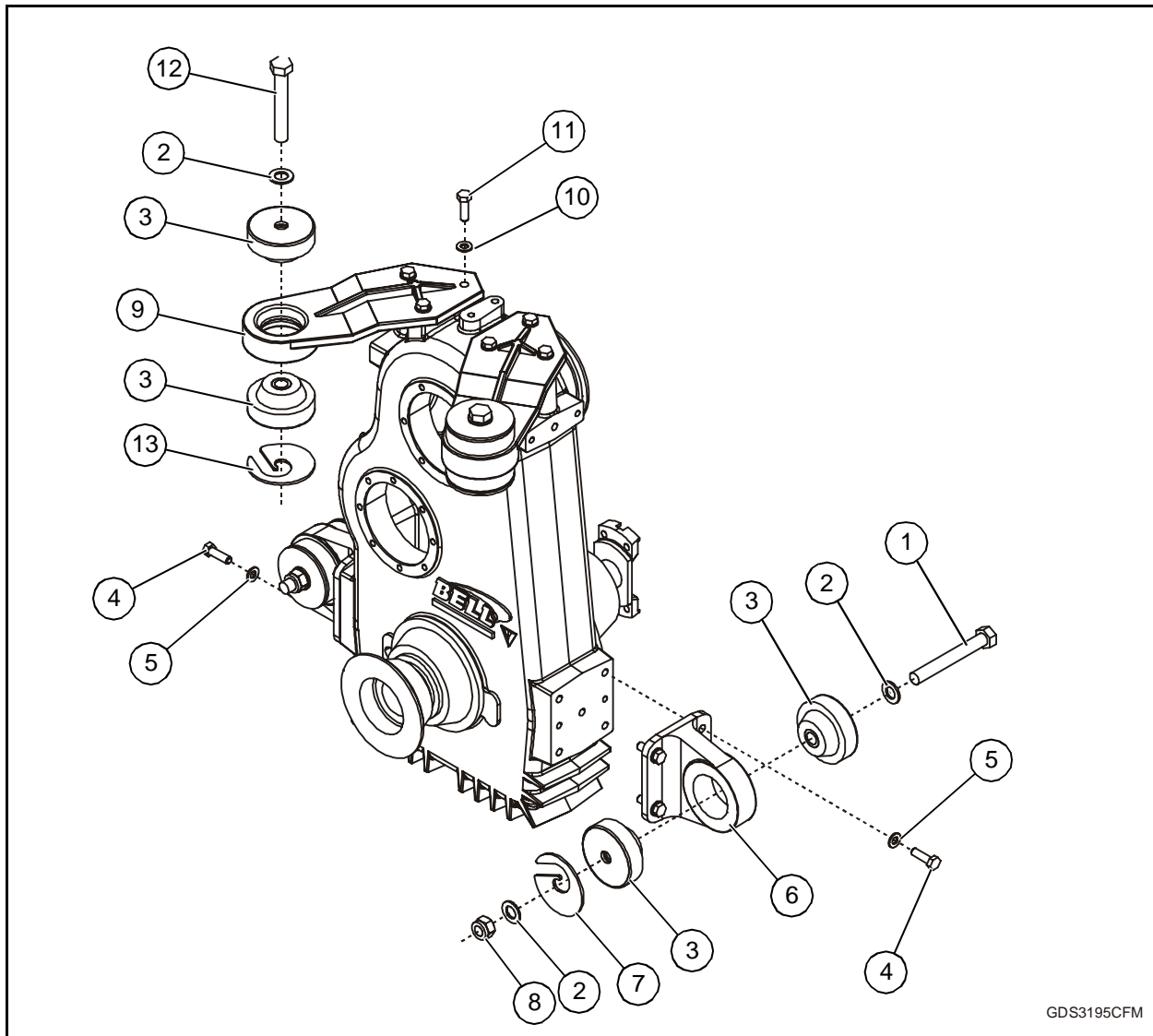

Attach transfer case to upper support brackets (9).

Install lower support brackets (6). Tighten bolts (4 and 11) to specification.

Remove and Install Transfer Case Specification

Support Bracket Cap Screw Torque -----
----- 110 Nm (81 lb-ft)

NOTE: If shim thicknesses (7 and 13) are known, install shims as removed. If transfer case housing has been replaced or thicknesses are not known, transfer case alignment must be done. Keep shims with relevant mountings.

Alignment

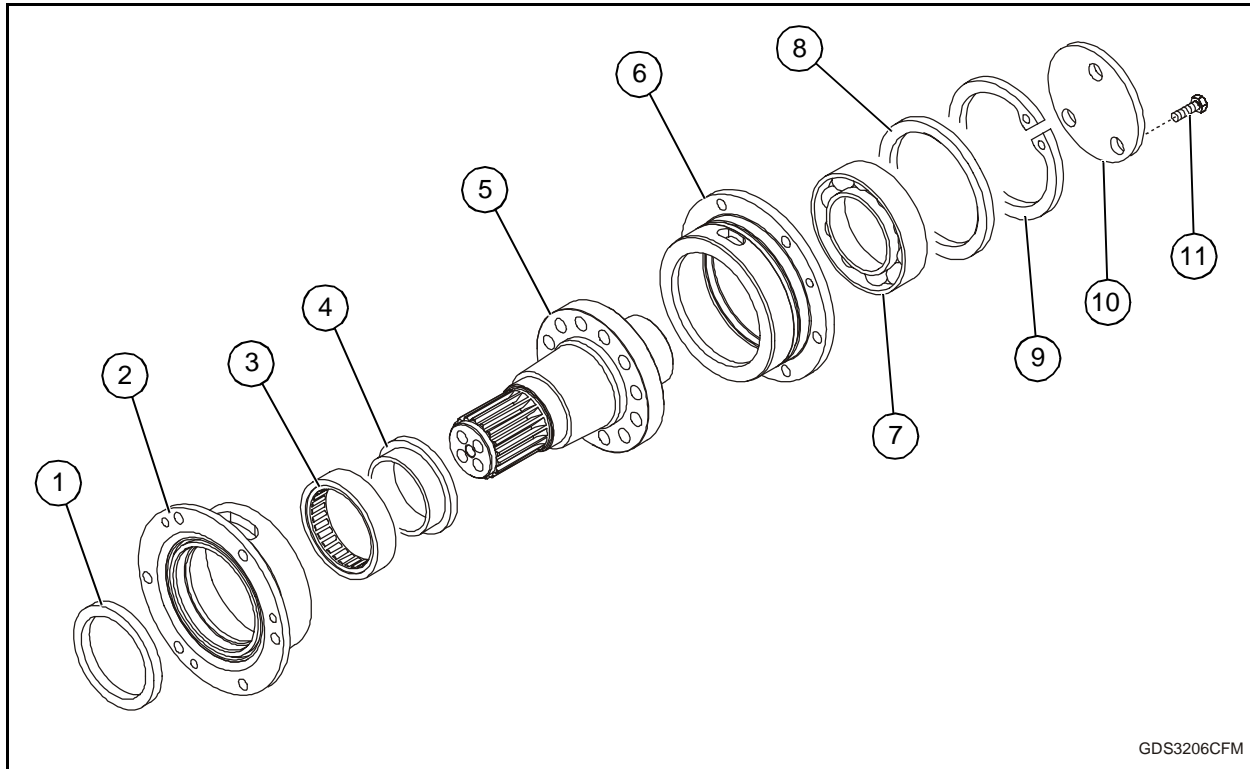

GDS3206CFM

- | | |
|---------------------------------------|--------------------|
| 1. Seal. | 7. Bearing. |
| 2. Input Shaft Front Bearing Housing. | 8. Spacer. |
| 3. Bearing. | 9. Snap Ring. |
| 4. Inner Race. | 10. Retainer. |
| 5. Input Shaft. | 11. Bolt (3 used). |
| 6. Input Shaft Rear Bearing Housing. | |

Disassemble and Assemble Input Shaft

Remove seal (1) from housing (2).

Remove bearing (3) from housing (2), using a bearing puller.

Remove inner race (4) from input shaft (5), using a bearing puller.

Remove retainer (10), snap ring (9), and spacer (8).

Support housing (6). Remove shaft (5), using a press.

Remove bearing (7), using a bearing puller.

Inspect and replace parts as necessary.

Heat housings (2 and 6) to 85°C (185°F). Install bearings (3 and 7).

▲ CAUTION

Open end of snap ring (9) must be aligned with oil hole in housing.

Install spacer (8) and snap ring (9). Ensure that open end of snap ring is aligned with oil hole in housing.

Heat inner race of bearing (7) to 85°C (185°F) and install input shaft (5).

Install retainer (10). Tighten bolts (11) to specification.

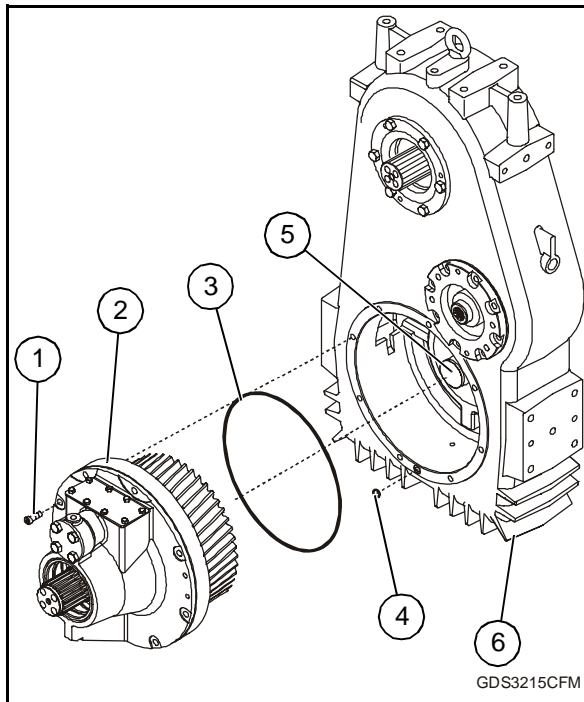

Apply a thin layer of petroleum jelly to O-rings (3 and 4). Install O-ring (3) on output gear assembly (2). Install O-ring (4) on transfer case (6).

▲ CAUTION

Align oil passages in transfer case (6) and output gear assembly (2).

Install two guide pins in transfer case (6). Install output gear assembly (2) in transfer case.

Ensure that oil passages are aligned. Remove guide pins. Install cap screws (1) and tighten to specification.

Transfer Case Specification

Front Output Assembly Cap Screw Torque -----
-----54 Nm (40 lb-ft)

NOTE: Access output gear through drain plug port.

Check backlash between idler gear and output gear.

Transfer Case Specification

Idler Gear to Output Gear Backlash -----
----- 0.25 - 0.42 mm (0.010 - 0.017 in.)

▲ CAUTION

Centering spring must be completely compressed while removing or installing sleeve or damage to valve housing bore will occur.



Install JDG1319 Steering Spool Remover in end of spool (10) and turn to compress centering spring (9). With centering spring compressed, push spool, sleeve, and drive shaft (13) out of housing.

Remove centering spring only if replacement is necessary. Spool, sleeve, and drive shaft are not serviceable. If parts are found worn or damaged, replace complete steering valve.

Remove parts (1 - 8), replace as necessary.

▲ CAUTION

Replace all seals and O-rings with new. Apply petroleum jelly to all seals and O-rings. Apply clean hydraulic oil to all internal parts while assembling.

Install seal (1), plug (3), and O-ring (4).



Install centering spring by inserting one end of spring in groove of spool and sleeve. Turn spring counterclockwise to compress and insert other end of spring in groove of spool and sleeve as shown.

Install thrust washers (6), snap ring (8), thrust bearing (7), and seal (5).

▲ CAUTION

Centering spring must be completely compressed while removing or installing sleeve or damage to valve housing bore will occur.

Compress spring using JDG1319 Steering Spool Remover and install spool and sleeve in housing.

Install balls (18) and roll pins (19) if removed.

Install parts (14 - 17) using scribe line as a guide.

Install cap screws (20). Tighten cap screws in a crisscross pattern to specification.

Steering Valve Specification

End Cap-to-Housing Cap Screws Initial Torque- - - - -
 ----- 17 Nm (150 lb-in.)

End Cap-to-Housing Cap Screws Final Torque - - - - -
 ----- 34 Nm (300 lb-in.)

CHAPTER 9. SERVICE BRAKES

SECTION 2. HYDRAULIC SYSTEM

BRAKE VALVE

Remove and Install Brake Valve

Relieve brake accumulator pressure. Pump service brake pedal repeatedly until no oil "hiss" is heard from accumulators.

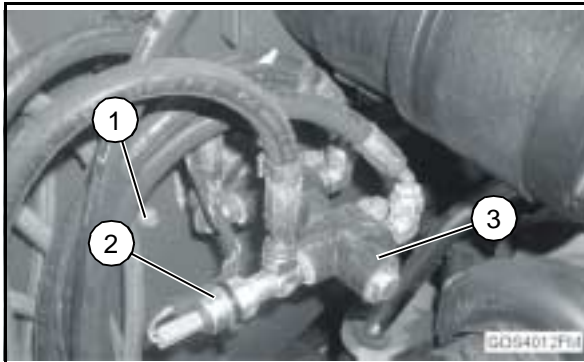

1. Cap Screw (4 used).
2. Sensor.
3. Brake Valve.

Disconnect wire leads from sensor (2).

Disconnect hydraulic lines. Close all openings with caps and plugs.

Remove cap screws (1).

Remove brake valve (3).

Inspect, repair, or replace parts as necessary.

Install brake valve.

Install cap screws.

Install hydraulic lines.

Install wire leads on sensor.

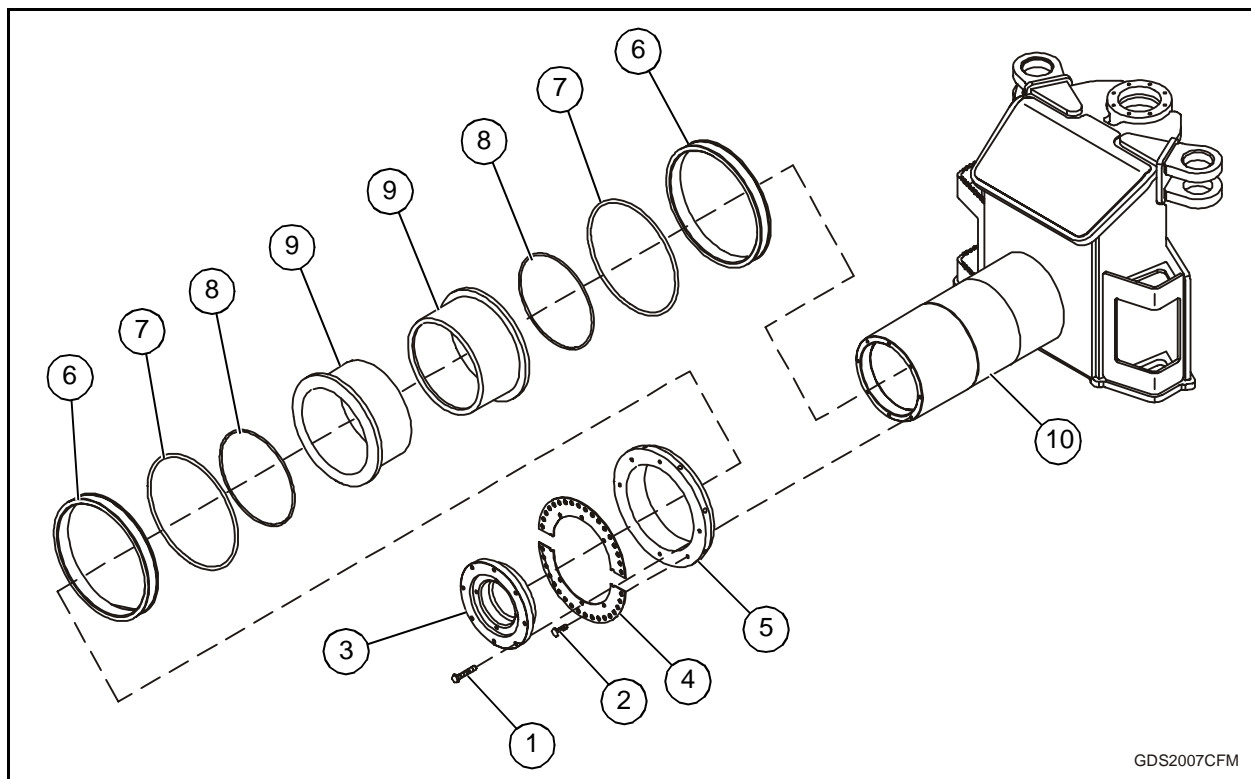

GDS2007CFM

1. Bearing Housing-to-Oscillation Tube Bolt (8 used).
2. Lock Plate-to-Spanner Nut Bolt (6 used).
3. Bearing Housing.
4. Lock Plate (2 used).
5. Spanner Nut.
6. Seal (2 used).
7. Outer O-Ring (2 used).
8. Inner O-Ring (2 used).
9. Oscillation Bushing (2 used).
10. Oscillation Tube.

Remove bolts (1 and 2). Remove locking plates (4). Install bolts (1).

▲ CAUTION

Component is heavy.

Separate Front and Rear Frames Specification

Spanner Nut Weight - - - - - 29 kg (63 lb) approximate

Remove spanner nut (5) using a spanner wrench.

Remove seal (6) and O-rings (7 and 8) from rear bushing (9).

Attach a forklift or other machine to rear towing point of equipment frame.

Slowly pull equipment frame rearward to separate oscillation joint. Adjust overhead hoist to keep tube and bushings aligned during separation.

Support front of equipment frame with 20-ton shop stands.

Remove seal (6) and O-rings (7 and 8) from front bushing (9). Discard seal and O-rings.

Clean, inspect, repair, and replace parts as necessary. **(See "DRIVE SHAFTS" on page 35)**

Apply a layer of all-purpose grease inside bushings. Pack space between bushings with grease.

Install new O-rings on front bushing. Apply a layer of all-purpose grease to O-rings and to lip of bushing. Install new seal over lip of bushing.

▲ CAUTION

Ensure that front bushing O-rings (7 and 8) and seal (6) are not damaged during assembly of oscillation joint.

Slowly push equipment frame forward. Adjust overhead hoist to maintain alignment of tube and bushings. Ensure that front bushing O-rings and seal are properly seated.

Disassemble and Assemble Cab Tilt Cylinder

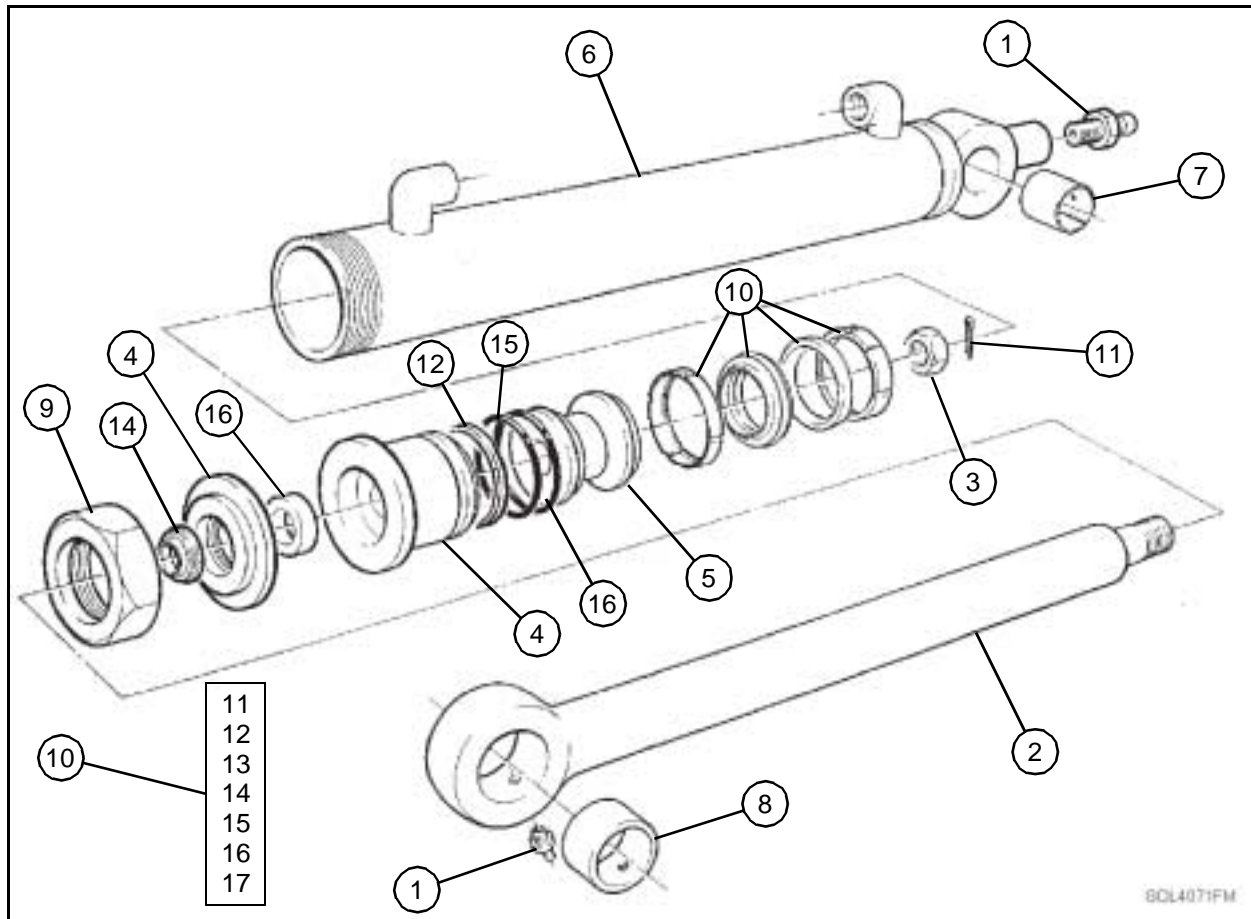

1. Lubrication Fitting (2 used).
2. Rod.
3. Nut.
4. Rod Guide.
5. Piston.
6. Hydraulic Cylinder Barrel
7. Bushing
8. Bushing
9. Nut.
10. Hydraulic Cylinder Kit.
11. Cotter Pin.
12. Backup Ring
13. Seal.
14. Seal.
15. O-Ring.
16. Seal.
17. O-Ring

Install cylinder in a service stand such as JT30043 Cylinder Service Stand.

Apply rigid form-in-place gasket to threads of nut (3).

Tighten nut to specification. Install cotter pin (11).

Cab Tilt Cylinder Specification

Piston-to-Rod Nut Torque - - - - - 500 Nm (370 lb-ft)

Apply clean hydraulic oil to seals (13) and O-rings (15 and 17) before installing piston and rod guide (4) into the barrel.

Apply an anti-seize lubricant to the threads of nut (9).

Follow manufacturer's instructions and charge system.

Add 1.8 kg (3.97 lb) refrigerant to system.

Air Conditioning System Specification

Air Conditioning System Refrigerant Refrigerant
Quantity ----- 1.8 kg (3.97 lb)

Check air conditioning for proper function. (See **Air Conditioning Operational Checks in CHAPTER 7, SECTION 3**).

Remove and Install Air Conditioner Compressor

Follow refrigerant cautions and proper handling procedures. (See **"REFRIGERANT CAUTIONS AND PROPER HANDLING"** on page 321).

Recover refrigerant. (See **"Recover R134a Refrigerant"** on page 324).

Open hood and lower bottom guard.

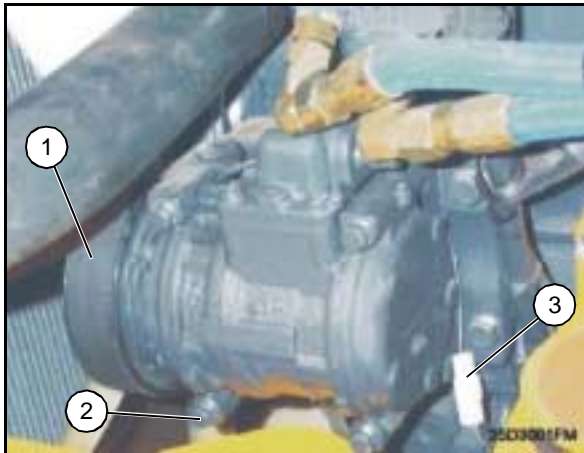

1. Fan Belt.
2. Cap Screw (4 used).
3. Clutch Solenoid Wire Connector.

Remove fan belt (1) from compressor pulley. (See **"FAN BELT"** on page 181).

Disconnect lines from suction and discharge ports (3 and 4). Close all openings using caps and plugs.

Disconnect compressor clutch solenoid wire connector (5).

Remove cap screws (2). Remove compressor.

Inspect, repair, or replace parts as necessary.

Before installing compressor, check oil. (See **"R134a REFRIGERANT OIL INFORMATION"** on page 322).

Install compressor. Install cap screws.

Connect clutch solenoid wire connector.

Connect lines to discharge and suction ports.

Install fan belt. (See **"FAN BELT"** on page 181).

Evacuate system. (See **"Evacuate R134a System"** on page 326).

Charge system. (See **"Charge R134a System"** on page 326).

Disassemble and Assemble Compressor Clutch

Follow refrigerant cautions and proper handling procedures. (See **"REFRIGERANT CAUTIONS AND PROPER HANDLING"** on page 321).

Remove compressor. (See **"Remove and Install Air Conditioner Compressor"** on page 327).

Install compressor on D01006AA Bench Mounted Holding Fixture.

Remove dust cover.

- Ensure latch arm returns to engaged position inside catch pin tube (6) when lever is released.
- Replace return spring (5), if necessary. Clean latch arm and catch pin tube.

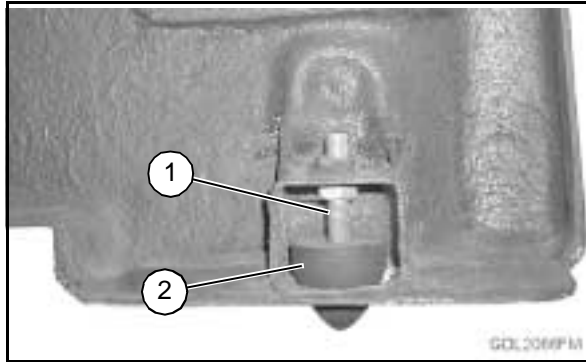

Adjust stoppers (1) to initial setup specification.

Bonnet Specification

Stopper Tip-to-Bonnet Lower Surface Initial Setup Distance ----- 20 mm (0.8 in.)

▲ CAUTION

Component is heavy. Use hoist.

Bonnet Specification

Bonnet Weight ----- 57 kg (125 lb) approximate

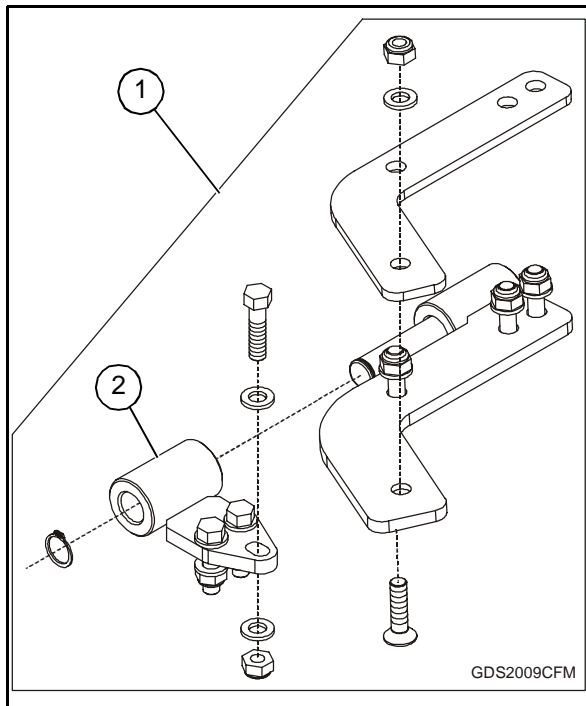

Install hinge assembly (1) on bonnet.

Lift bonnet with hoist. Install spacers and hinges to frame.

Tighten hardware enough to eliminate gaps between contact surfaces, but ensure that flanges (4 and 5) are loose enough to allow adjustment.

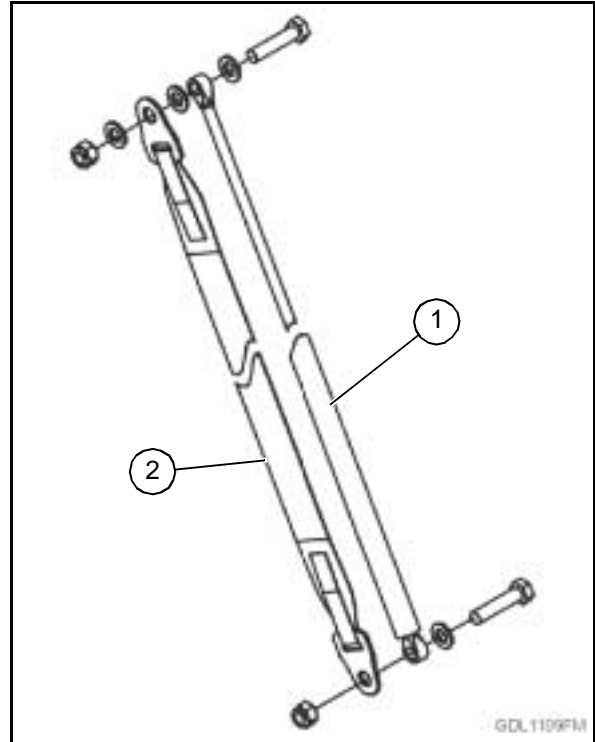

5. Install struts (1) and straps (2).

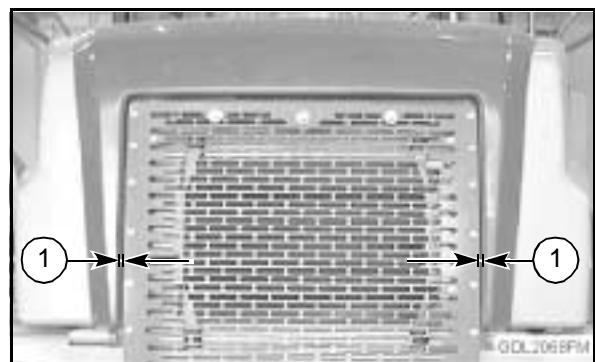

1. Bonnet-to-Grille Gap

Lower bonnet. Adjust bonnet left-to-right alignment. Bonnet-to-grille gaps (1) should be equal on left and right sides.

Raise bonnet slowly. Ensure that bonnet does not shift left or right. Tighten bonnet-mounted flanges of hinges.

Clean and inspect parts for wear or damage.

Disassemble valve as shown.

▲ CAUTION

Replace all seals and O-rings. Old seals and O-rings will leak.

Valve housing and main spool are a matched set. If either is found worn or damaged they must be replaced as a matched set.

**NOTE: Apply petroleum jelly to seals and O-rings before installation.
Apply clean hydraulic oil to all internal parts before assembling.**

Assemble parts (1 - 39).

NOTE: If an adapter is fastened to the square drive of a torque wrench, it adds to the leverage distance of the wrench. In this case, the real torque applied is greater than the torque indicated by the torque wrench. Use the formula below to determine the correct torque wrench reading for the intended torque specification.

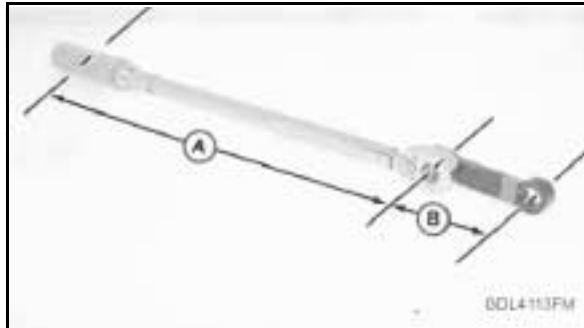

- A. Leverage Distance of Torque Wrench
- B. Leverage Distance of Adapter

Torque Reading on = Torque Specification x Wrench A + B

NOTE: 1. Leverage distance of torque wrench is measured from center of handle to center of square drive. Leverage distance of wrench with adapter is measured parallel to beam of wrench, from center of handle to center of adapter head.
2. Always measure leverage distance parallel to beam of wrench. If wrench and adapter are assembled at an angle, leverage distance will be shorter. If adapter is assembled at 90° to beam of wrench, it does not affect leverage distance.

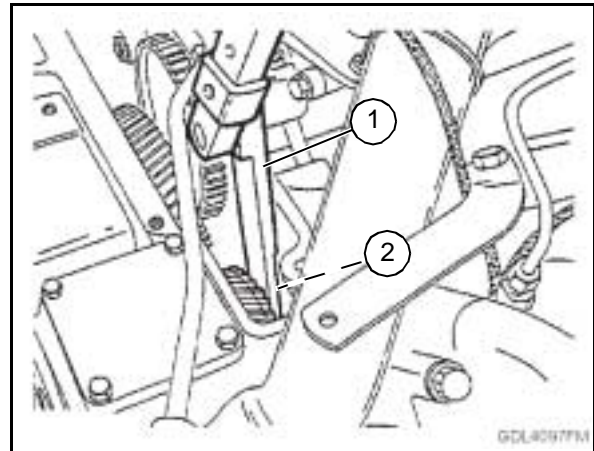

Using a torque wrench and JDG1500-40 Drive Gear Wrench (1), tighten cap screw (2) to specification.

Remove and Install Air Compressor Specification

Drive Gear Cap Screw Torque-----
----- 360 Nm (266 lb-ft) actual

Remove JDG1500-39 Air Compressor Crankshaft Blocker.

Install Connecting Rod And Piston

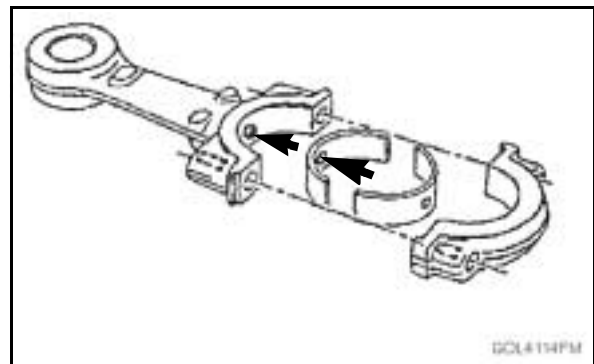

Lightly coat connecting rod bearings with clean oil. Install bearings into connecting rod bearing cap and connecting rod.

Ensure that oil holes (arrows) in connecting rod bearing and connecting rod align. Ensure the markings on connecting rod cap and connecting rod align.

CHAPTER 15. PNEUMATIC SYSTEMS

SECTION 3. RESERVOIR, FILTER AND TRAP

AIR UNLOADER VALVE WITH INTEGRAL AIR DRYER

Remove and Install Air Unloader Valve

Turn off battery disconnect switch. (See **Battery Disconnect Switch and Battery Circuit Breaker Operator's Manual CHAPTER 2, SECTION 3**).

Relieve pneumatic pressure. (See **Relieve Pneumatic Pressure Operator's Manual CHAPTER 7, SECTION 1**).

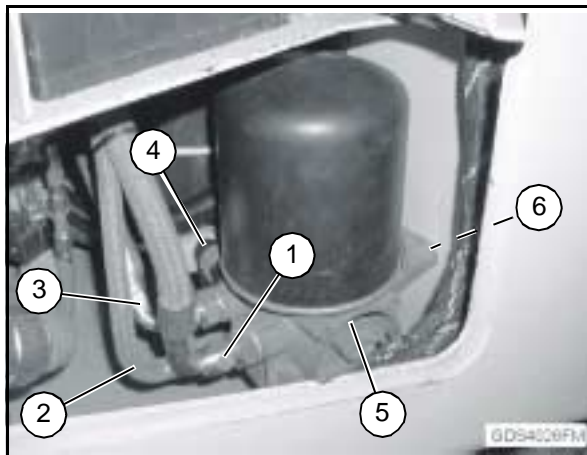

Disconnect heater wire (4).

Disconnect air lines (1 - 3).

Loosen cap screws (6).

Remove unloader valve assembly (5) from machine.

Repair or replace parts as necessary.

Install unloader valve assembly.

Tighten cap screws.

Connect air lines.

Connect heater wire.

Disassemble and Assemble Air Unloader Valve

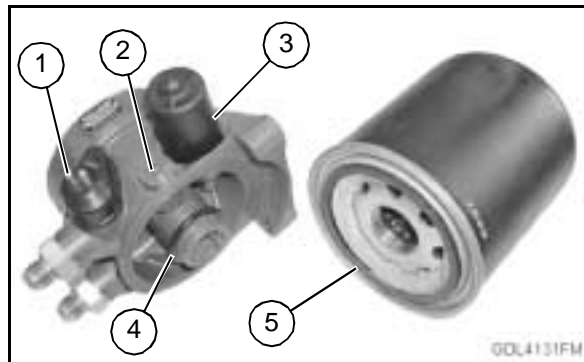

Remove element (5) and O-ring (4).

Remove heater and screw (1), if necessary.

Remove plug and sealing ring (2), if necessary.

▲ CAUTION

Spring is under load. Hold component securely while removing snap ring.

Remove snap ring and unloader valve spring assembly (3), if necessary.

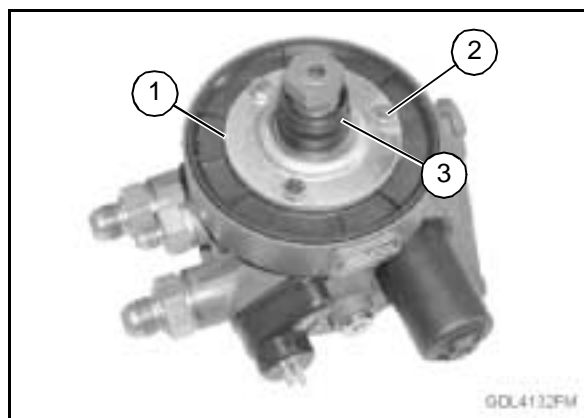

Remove cap screws (1), retaining ring (2), and drain port (3).

CHAPTER 16. HAULAGE DEVICE

SECTION 2. HYDRAULIC SYSTEM

BIN TIP CYLINDER

Remove and Install Bin Tip Cylinder

Install articulation lock bar. Install wheel chocks. Fully lower dump body. Discharge hydraulic pressure. **(See Prepare Machine for Maintenance Operator's Manual CHAPTER 7).**

▲ CAUTION

Component is heavy. Use hoist.

Bin Tip Cylinder Specification

Bin Tip Cylinder Weight -----
----- 191 kg (420 lb) approximate

Support cylinder with hoist.

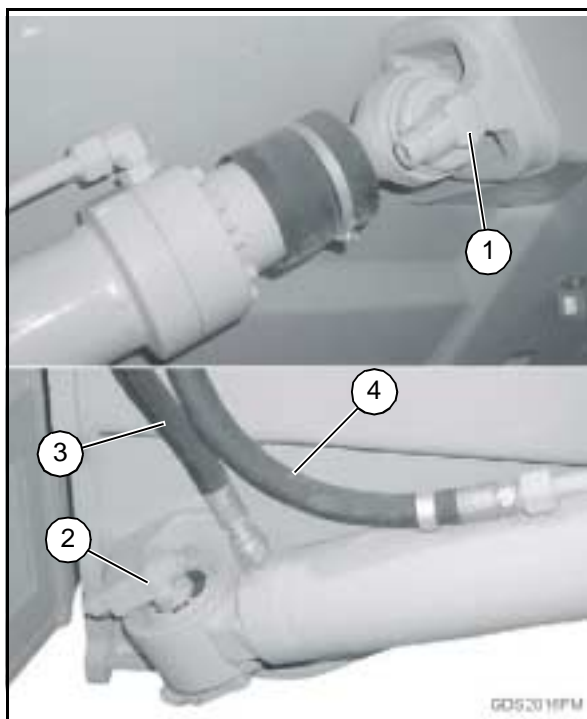

Disconnect hydraulic lines (3 and 4). Close all openings with caps and plugs.

Disconnect pins (1 and 2). Remove cylinder from machine.

Clean, repair, and replace parts as necessary.

NOTE: Rotate cylinder so hydraulic fittings are on top.

Install cylinder on machine. Adjust rod lengths, if necessary.

Connect hydraulic lines.

Disassemble and Assemble

▲ CAUTION

Component is heavy. Use hoist.

Bin Tip Cylinder Specification

Bin Tip Cylinder Weight -----
----- 191 kg (420 lb) approximate

Install cylinder in a cylinder service stand such as JT30043 Cylinder Service Stand.

DFT1197 FRONT SUPPORT

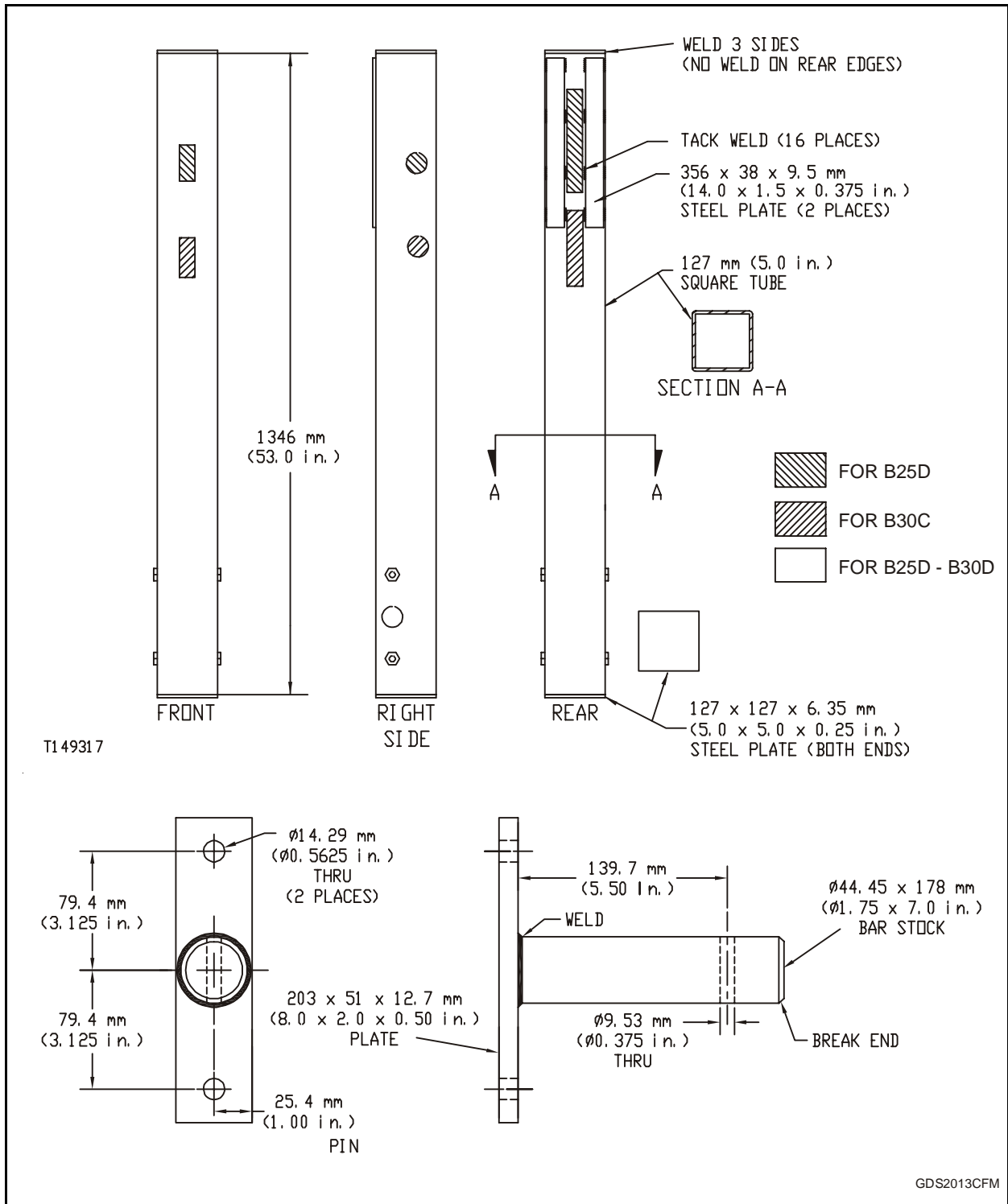

Continues on next page.

CLICK HERE TO **DOWNLOAD** THE COMPLETE MANUAL

- Thank you very much for reading the preview of the manual.
- You can download the complete manual from: www.heydownloads.com by clicking the link below



- Please note: If there is no response to CLICKING the link, please download this PDF first and then click on it.

CLICK HERE TO **DOWNLOAD** THE COMPLETE MANUAL