

## Identification Codes

### Vehicle Identification Number (VIN) Locator

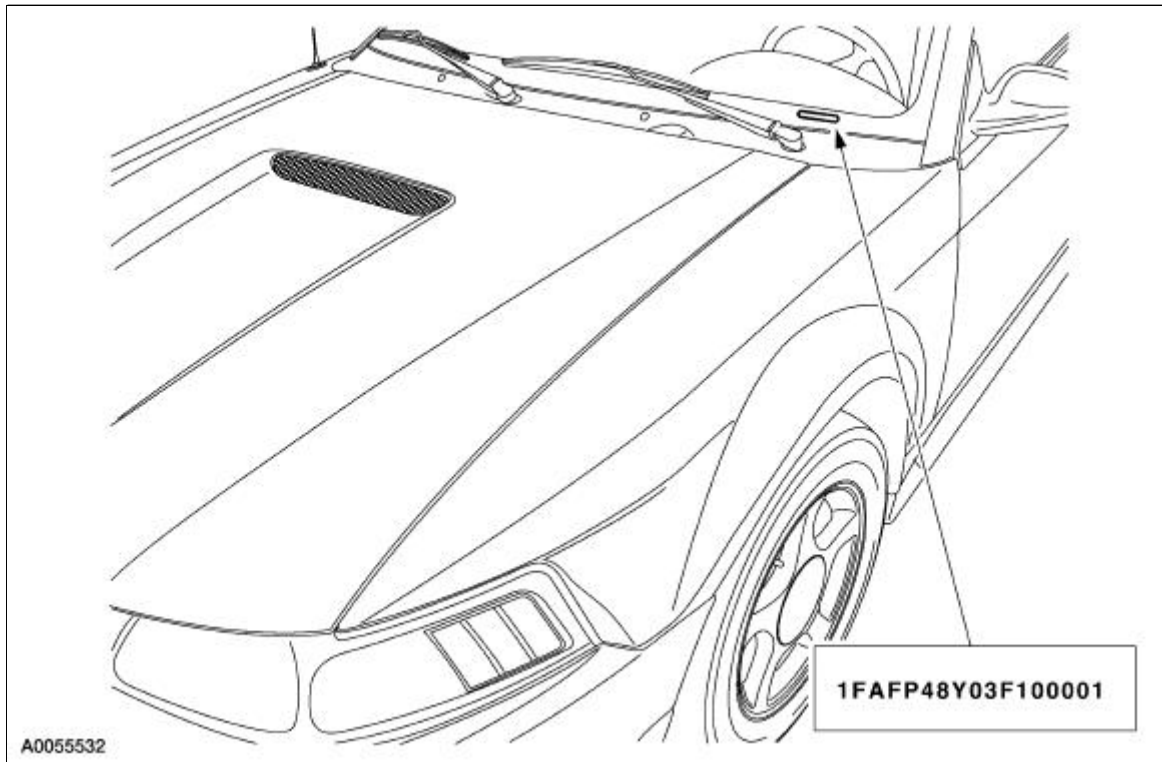

The vehicle identification number (VIN) is a seventeen-digit alphanumeric code. The VIN is stamped on a metal tab riveted to the instrument panel, top upper left of the dash. The VIN number is also found on the vehicle certification (VC) label.

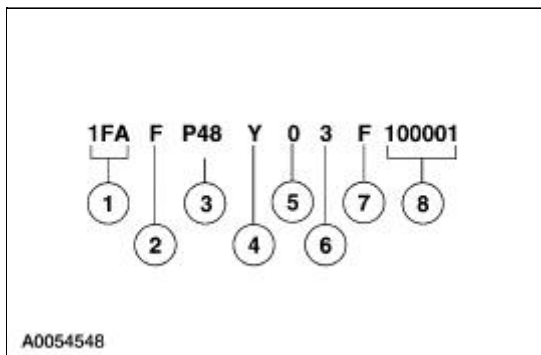

Item	Description
1	World manufacturer identifier (WMI)
2	Restraint type code
3	Line, series, body type (passenger car)
4	Engine code

CLICK HERE TO **DOWNLOAD** THE COMPLETE MANUAL

- Thank you very much for reading the preview of the manual.
- You can download the complete manual from: [www.heydownloads.com](http://www.heydownloads.com) by clicking the link below



- Please note: If there is no response to CLICKING the link, please download this PDF first and then click on it.

CLICK HERE TO **DOWNLOAD** THE COMPLETE MANUAL

- Frequencies have a range of plus or minus 2. A reading of 10 Hz can be displayed as an 8 Hz through 12 Hz.
- d. Place the vibration sensor on or near the suspect area outside the vehicle.
- e. Continue the road test, driving the vehicle at the speed the symptom occurs, and take another reading.
- f. Compare the readings.
  - A match in frequency indicates the problem component or area.
  - An unmatched test could indicate the concern is caused by the engine, torque converter, or engine accessory. Use the EVA in the rpm mode and check if concern is rpm related.
  - Example: A vibration is felt in the seat. Place the sensor on the console. Record the readings. Place the vibration sensor on the rear axle. Compare the readings. If the frequencies are the same, the axle is the problem component.

## **Vibrate Software®**

Vibrate Software® (Rotunda tool number 215-00003) is a diagnostic aid which will assist in pinpointing the source of unacceptable vibrations. The engine's crankshaft is the point of reference for vibration diagnosis. Every rotating component will have an angular velocity that is faster, slower, or the same as the engine's crankshaft. Vibrate Software® calculates the angular velocity of each component and graphically represents these velocities on a computer screen and on a printed vibration worksheet. The following steps outline how Vibrate Software® helps diagnose a vibration concern:

- Enter the vehicle information. Vibrate will do all the calculations and display a graph showing tire, driveshaft and engine vibrations.
- Print a Vibration Worksheet graph. The printed graph is to be used during the road test.
- Road test the vehicle at the speed where the vibration is most noticeable. Record the vibration frequency (rpm) and the engine rpm on the worksheet graph. The point on the graph where the vibration frequency (rpm) reading and the engine rpm reading intersect indicates the specific component group causing the concern.
  - An EVA or equivalent tool capable of measuring vibration frequency and engine rpm will be needed.
- Provide pictures of diagnostic procedures to aid in testing components.

## **Combination EngineEAR/ChassisEAR**

An electronic listening device used to quickly identify noise and the location under the chassis while the vehicle is being road tested. The ChassisEARs can identify the noise and location of damaged/worn wheel bearings, CV joints, brakes, springs, axle bearings or driveshaft carrier bearings.

## **EngineEAR Basic Unit**

An electronic listening device used to detect even the faintest noises. The EngineEARs can detect the noise of damaged/worn bearings in generators, water pumps, A/C compressors and power steering pumps. They are also used to identify noisy lifters, exhaust manifold leaks, chipped gear teeth and for detecting wind noise. The EngineEAR has a sensing tip, amplifier, and headphones. The directional sensing tip is used to listen to the various components. Point the sensing tip at the suspect component and adjust the volume with the amplifier. Placing the tip in direct contact with a component will reveal structure-borne noise and vibrations, generated by or passing through, the component. Various volume levels can reveal different sounds.

## **Ultrasonic Leak Detector**

The Ultrasonic Leak Detector is used to detect wind noises caused by leaks and gaps in areas where there is weather-stripping or other sealing material. It is also used to identify A/C leaks, vacuum leaks

### Symptom Chart—Transmission (Manual) and Transfer Case Noise/Vibration

Condition	Possible Sources	Action
<ul style="list-style-type: none"> <li>● Clutch rattling noise—occurs with clutch engaged, noise changes/disappears with clutch pedal depressed</li> </ul>	<ul style="list-style-type: none"> <li>● Flywheel bolts, clutch housing bolts or clutch pressure plate bolts loose.</li> </ul>	<ul style="list-style-type: none"> <li>● TIGHTEN the bolts to specifications. CHECK the bolts for damage.</li> </ul>
<ul style="list-style-type: none"> <li>● Clutch squeaking noise—noise is heard when the clutch is operated. Vehicle moves slowly or creeps when the clutch is disengaged. Can also be difficult to shift into first and reverse gear</li> </ul>	<ul style="list-style-type: none"> <li>● Pilot bearing seized or damaged.</li> </ul>	<ul style="list-style-type: none"> <li>● INSTALL a new pilot bearing. REFER to <a href="#">Section 308-01</a>.</li> </ul>
<ul style="list-style-type: none"> <li>● Clutch squeaking noise—occurs with clutch pedal depressed/released</li> </ul>	<ul style="list-style-type: none"> <li>● Worn clutch pedal shaft or bushings.</li> </ul>	<ul style="list-style-type: none"> <li>● INSPECT the clutch pedal for wear or damage. REPAIR as necessary. REFER to <a href="#">Section 308-02</a>.</li> </ul>
<ul style="list-style-type: none"> <li>● Clutch whirring/rattle noise—occurs when clutch pedal is depressed</li> </ul>	<ul style="list-style-type: none"> <li>● Worn, damaged or misaligned clutch release bearing.</li> </ul>	<ul style="list-style-type: none"> <li>● INSTALL a new clutch release bearing. REFER to <a href="#">Section 308-01</a>.</li> </ul>
<ul style="list-style-type: none"> <li>● Clutch grating/grinding noise—occurs when clutch pedal is depressed</li> </ul>	<ul style="list-style-type: none"> <li>● Clutch pressure plate fingers bent or worn.</li> <li>● Contact surface of clutch release bearing worn or damaged.</li> </ul>	<ul style="list-style-type: none"> <li>● INSPECT the clutch pressure plate release fingers. INSTALL a new pressure plate as necessary. REFER to <a href="#">Section 308-01</a>.</li> <li>● INSTALL a new clutch release bearing. REFER to <a href="#">Section 308-01</a>.</li> </ul>
<ul style="list-style-type: none"> <li>● Clutch chatter—a small amount of noise when clutch pedal is released at initial take-off</li> </ul>	<ul style="list-style-type: none"> <li>● Clutch engagement.</li> </ul>	<ul style="list-style-type: none"> <li>● Acceptable operating condition.</li> </ul>
<ul style="list-style-type: none"> <li>● Clutch chatter/grabs—in some cases a shudder is felt. Occurs with clutch pedal depressed/released</li> </ul>	<ul style="list-style-type: none"> <li>● Damaged or worn powertrain/driveline mounts.</li> <li>● Binding or dragging plunger of the clutch master cylinder or slave cylinder.</li> </ul>	<ul style="list-style-type: none"> <li>● INSPECT the powertrain/drivetrain mounts. INSTALL new mounts as necessary. REFER to <a href="#">Section 303-01A</a> for 3.8L engines or <a href="#">Section 303-01B</a> for 4.6L (2V) engines.</li> <li>● CHECK the master and slave cylinder operation. INSPECT the components for damage or wear. INSTALL a new master or slave cylinder as necessary. REFER to</li> </ul>

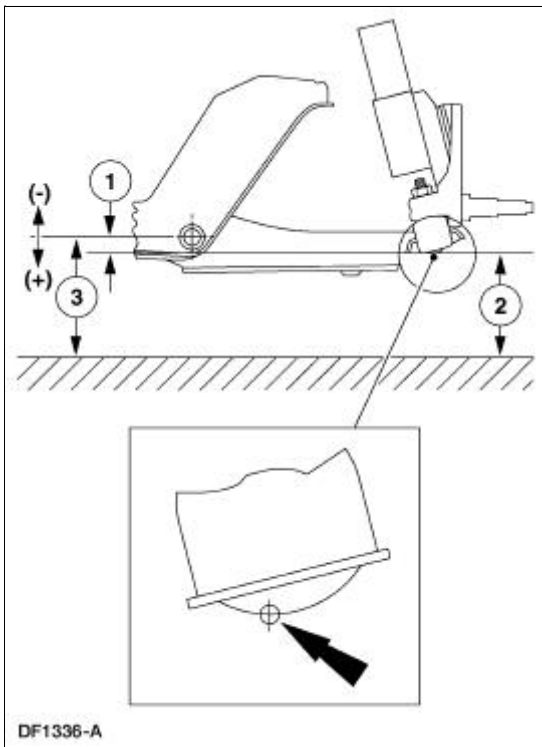

Item	Description
1	Ride height = B - A
2	Measurement A
3	Measurement B

### Rear Ride Height Measurement — GT and Base

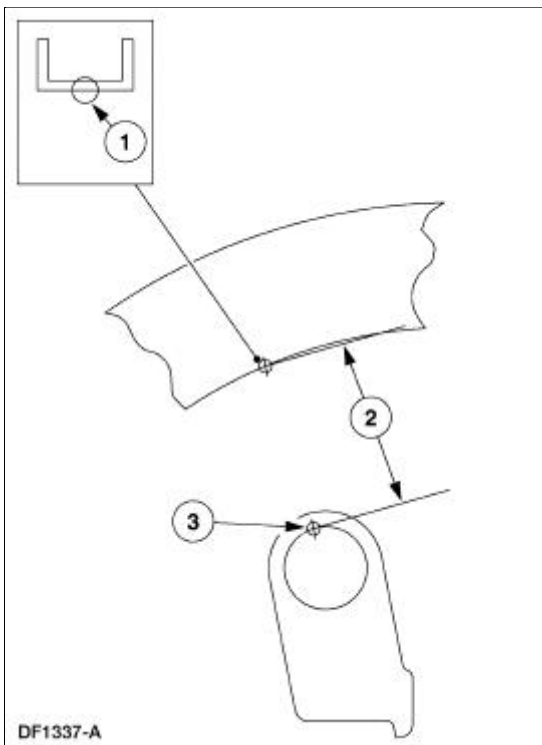

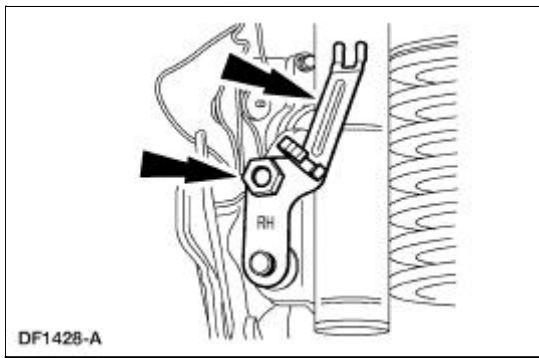

7. Support the front suspension lower arm (3078) with a jack stand.
8. Disconnect the shock absorber (18124) from the spindle (3105).
  1. Remove and discard the nuts and bolts.
  2. Disconnect the shock absorber.

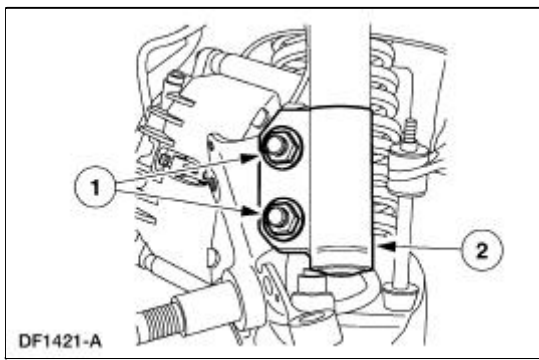

9. Carefully lower the front suspension lower arm and remove the jack stand.
10.  **CAUTION: Do not allow the weight of the vehicle to rest on the front brake disc shield. Damage to the shield can occur.**

Lower the vehicle to access the upper mount nuts and bolt.

11. Remove the shock absorber.
  1. Remove the bolt and nuts. Discard the nuts.
  2. Remove the shock absorber.

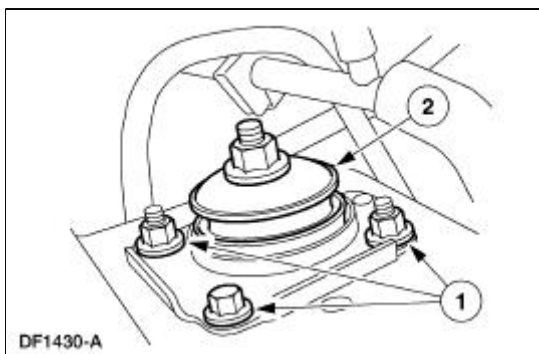

12. Position the shock absorber in a vise.
13. Remove the nut and the front shock absorber mounting bracket (18183).

## Wheel Knuckle —Cobra

### Special Tool(s)

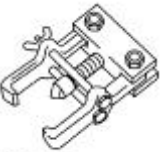
 ST2272-A	Front Hub Remover 205-D070 (D93P-1175-B) or Equivalent
 ST2273-A	Steering Arm Remover 211-003 (T64P-9171-A)

### Removal

**!** **CAUTION:** Suspension fasteners are critical parts because they affect performance of vital components and systems and their failure can result in major service expense. A new part with the same part number must be installed if installation becomes necessary. If substitution is necessary, the part must be of the same finish and property class. Torque values must be used as specified during reassembly to make sure of correct retention of these parts.

1. Mark the rear shock absorber (18125) relative to the protective sleeve with the vehicle in a static, level ground position (curb height).

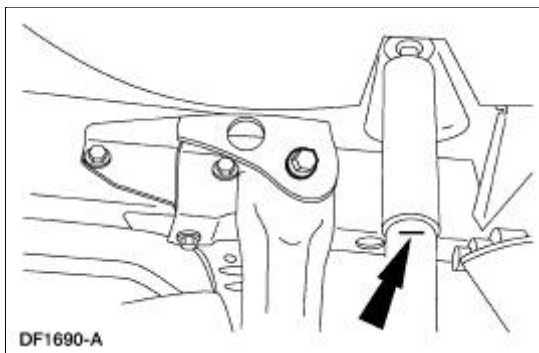

2. Raise the vehicle on a hoist. For additional information, refer to [Section 100-02](#).
3. Remove the wheel and tire assembly. For additional information, refer to [Section 204-04](#).
4. Remove and discard the rear hub retainer (4B477).



## Universal Joint —Single Cardan, Flange Yoke

### Special Tool(s)

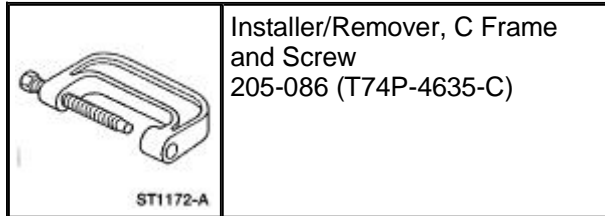

### Disassembly

1. Remove the driveshaft (4602). For additional information, refer to [Driveshaft](#) in this section.
2.  **CAUTION:** Under no circumstances is the driveshaft assembly to be clamped in the jaws of a vise or similar holding fixture. Denting or localizing fracture can result, causing driveshaft failure during vehicle operation.

Place the driveshaft on a suitable workbench, being careful not to damage the tube.

3. **NOTE:** If components are not marked and installed correctly, driveline imbalance can occur.

Index-mark the positions of the driveshaft components.

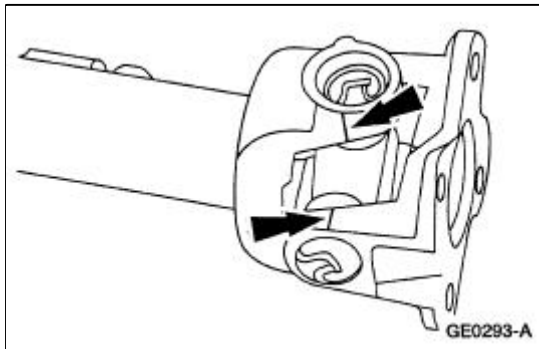

4. Clamp the U-joint tool in a vise.

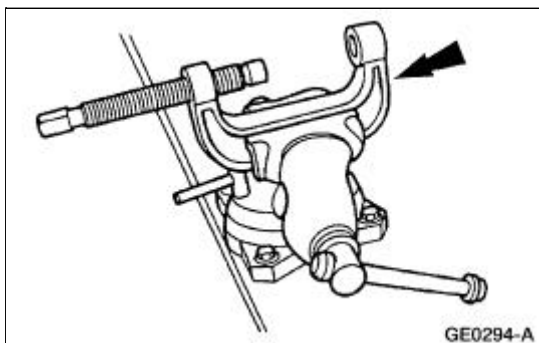

5. Remove all four of the snap rings.

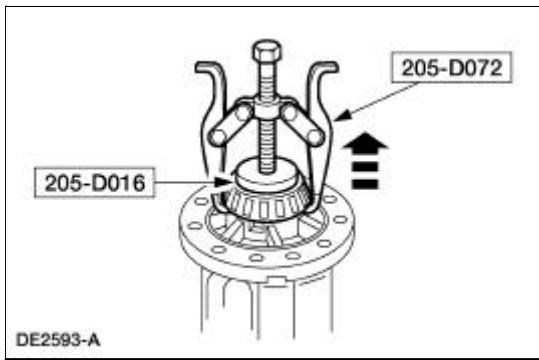

16. Using the special tool, install the new differential bearings.

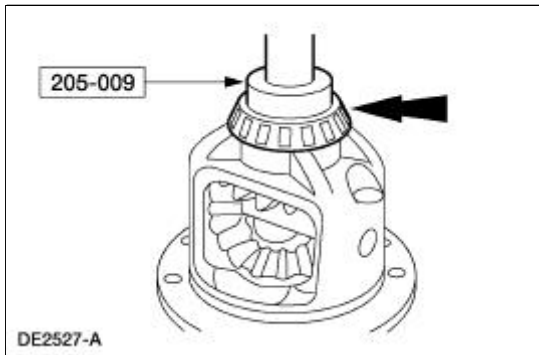

17. Position the differential assembly, including the differential bearing cups and differential bearing shims, in the differential housing. Install the bearing caps and bolts.

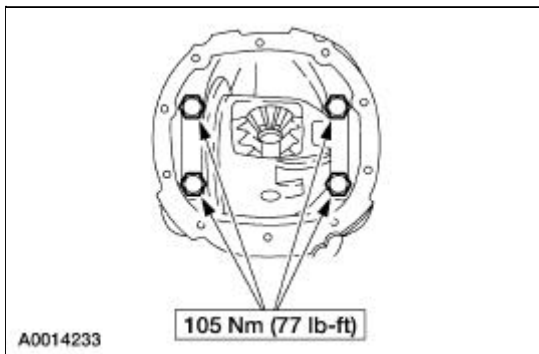

18. Position the special tool.  
 1. Rotate the differential case to verify that the differential bearings have seated correctly.  
 2. Position the special tool.

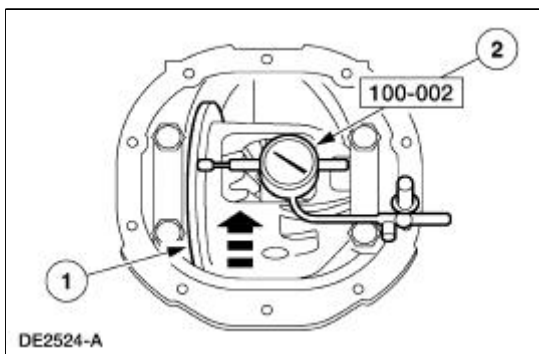

19. Measure the differential case runout.

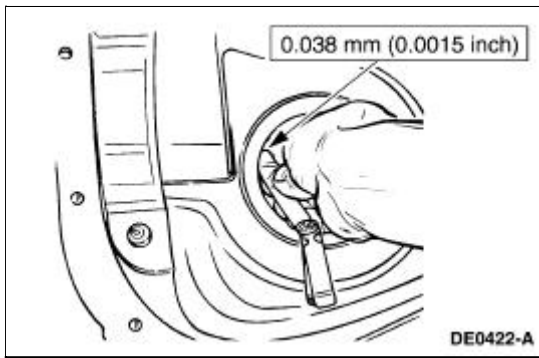

### Setting pinion depth

7. **NOTE:** Apply only a light oil film on the differential pinion bearings before assembling the tools.

Assemble and position the following in the differential housing.

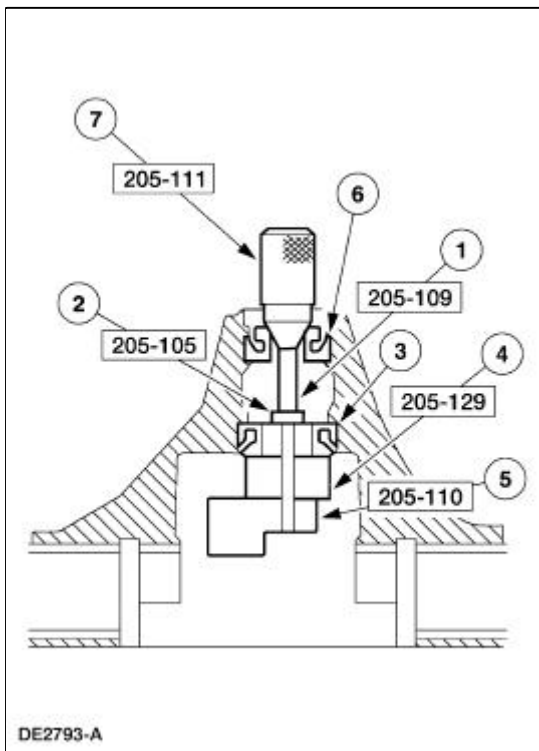

Item	Part Number	Description
1	205-109	Adapter for 205-S127 (T76P-4020-A9)
2	205-105	Adapter for 205-S127 (T76P-4020-A3) (1.612 inch O.D.)
3	4630	Rear (inner) pinion bearing
4	205-129	Adapter for 205-S127 (T79P-4020-A18) (1.1884 inch thick)
5	205-110	Adapter for 205-S127 (T76P-4020-A10) (1.7 inch thick)
6	4621	Front (outer) pinion bearing
7	205-111	Adapter for 205-S127 (T76P-4020-A11)

8. **NOTE:** This step duplicates final differential pinion bearing preload.

## Rear Drive Axle and Differential

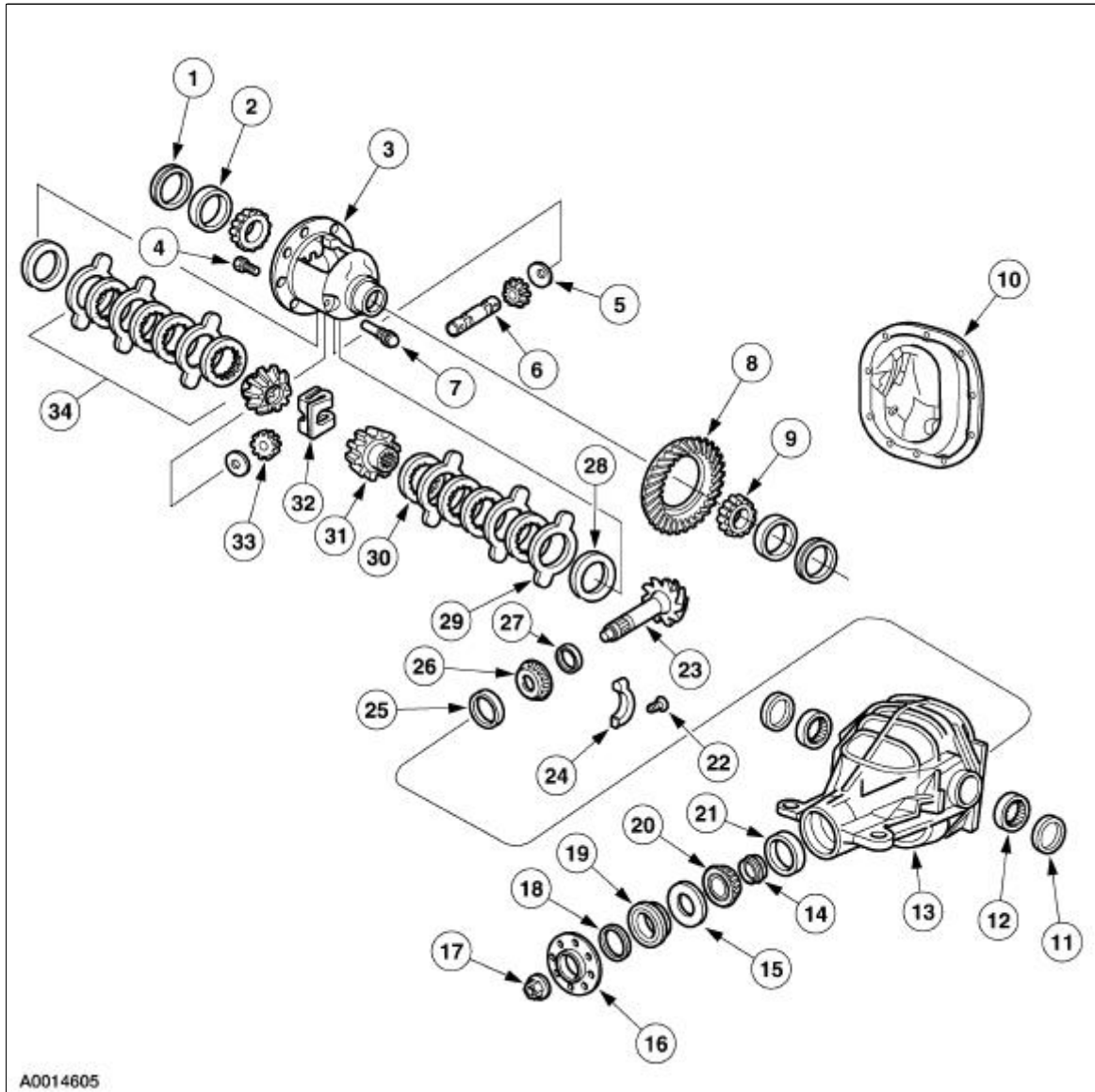

Item	Part Number	Description
1	4067	Differential bearing shim
2	4222	Differential bearing cup
3	4204	Differential case
4	4216	Differential ring gear case bolt
5	4230	Differential pinion thrust washer
6	4211	Differential pinion shaft
7	4241	Differential pinion shaft lock bolt
8	—	Differential ring gear (part of 4209)
9	4221	Differential bearing

bearings.

Install the pinion bearings and special tools as shown.

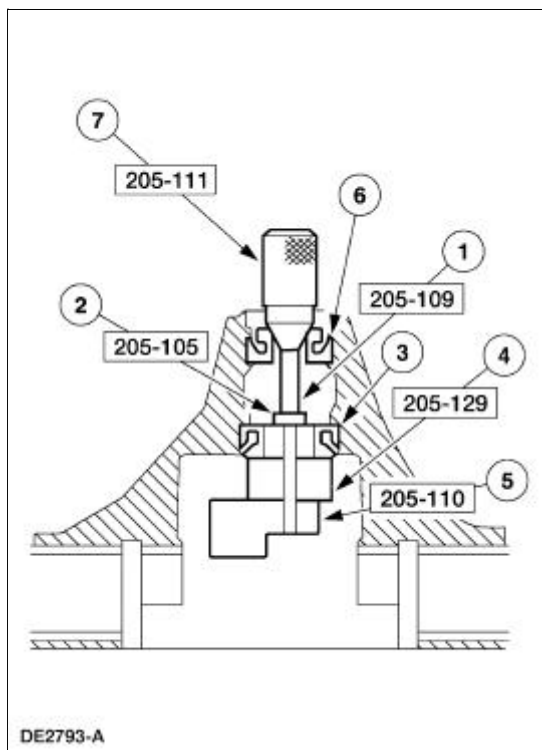

Item	Part Number	Description
1	205-109	Adapter for 205-S127
2	205-105	Adapter for 205-S127
3	4630	Rear (inner) pinion bearing
4	205-129	Adapter for 205-S127
5	205-110	Adapter for 205-S127
6	4621	Front (outer) pinion bearing
7	205-111	Adapter for 205-S127

4. **NOTE:** This step duplicates pinion bearing preload.

Thread the special tool onto the Screw and tighten to the specification shown.

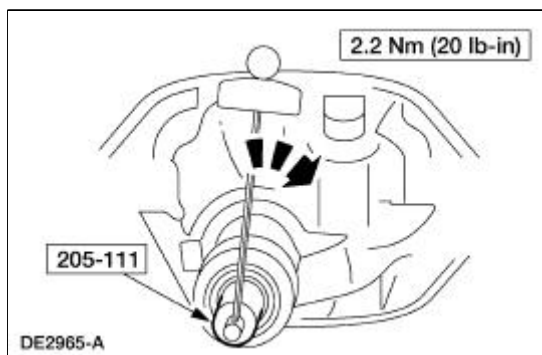

5. **CAUTION:** Offset the special tool to obtain an accurate reading.

Always On	<ul style="list-style-type: none"> <li>● Parking brake.</li> <li>● Brake fluid level.</li> </ul>	
<ul style="list-style-type: none"> <li>● Vibration When Brakes Are Applied</li> </ul>	<ul style="list-style-type: none"> <li>● Rear disc brakes.</li> <li>● Front disc brakes.</li> </ul>	<ul style="list-style-type: none"> <li>● REFER to <a href="#">Section 100-04</a>.</li> </ul>
<ul style="list-style-type: none"> <li>● Brake Pedal Goes Down Fast</li> </ul>	<ul style="list-style-type: none"> <li>● Brake fluid level.</li> <li>● Air in system.</li> <li>● Brake master cylinder.</li> </ul>	<ul style="list-style-type: none"> <li>● FILL the brake master cylinder reservoir. BLEED the system.</li> <li>● BLEED the system.</li> <li>● PERFORM the brake master cylinder component test in this section.</li> </ul>
<ul style="list-style-type: none"> <li>● The Brake Pedal Eases Down Slowly</li> </ul>	<ul style="list-style-type: none"> <li>● Air in system.</li> <li>● Brake master cylinder.</li> </ul>	<ul style="list-style-type: none"> <li>● BLEED the system. REFER to Bleeding — System in this section.</li> <li>● PERFORM the brake master cylinder component test in this section.</li> </ul>
<ul style="list-style-type: none"> <li>● Brake Lockup During Light Brake Pedal Force</li> </ul>	<ul style="list-style-type: none"> <li>● Disc brake component.</li> <li>● Parking brake component.</li> <li>● Anti-lock brake control system.</li> </ul>	<ul style="list-style-type: none"> <li>● <a href="#">Go To Pinpoint Test C</a>.</li> </ul>
<ul style="list-style-type: none"> <li>● Excessive/Erratic Brake Pedal Travel</li> </ul>	<ul style="list-style-type: none"> <li>● Leak in hydraulic system.</li> <li>● Air in system.</li> <li>● Disc brake caliper.</li> <li>● Brake master cylinder.</li> </ul>	<ul style="list-style-type: none"> <li>● <a href="#">Go To Pinpoint Test D</a>.</li> </ul>
<ul style="list-style-type: none"> <li>● Brakes Drag</li> </ul>	<ul style="list-style-type: none"> <li>● Parking brake component.</li> <li>● Disc brake caliper.</li> <li>● Brake booster-to-brake master cylinder push rod adjustment.</li> <li>● Brake master cylinder.</li> </ul>	<ul style="list-style-type: none"> <li>● REPAIR or INSTALL new components as necessary. REFER to <a href="#">Section 206-05</a>.</li> <li>● REPAIR or INSTALL a new brake caliper as necessary. REFER to <a href="#">Section 206-03</a> and <a href="#">Section 206-04</a>.</li> <li>● ADJUST the push rod. REFER to <a href="#">Section 206-07</a>.</li> <li>● PERFORM the brake master cylinder component test in this section.</li> </ul>
<ul style="list-style-type: none"> <li>● Excessive Brake Pedal Effort</li> </ul>	<ul style="list-style-type: none"> <li>● Power brake booster.</li> <li>● Power brake booster check valve (2365).</li> <li>● Power brake booster hose.</li> </ul>	<ul style="list-style-type: none"> <li>● PERFORM the brake booster component test in this section.</li> <li>● PERFORM the check valve component test in this section.</li> <li>● REROUTE, REPAIR or INSTALL a new brake</li> </ul>

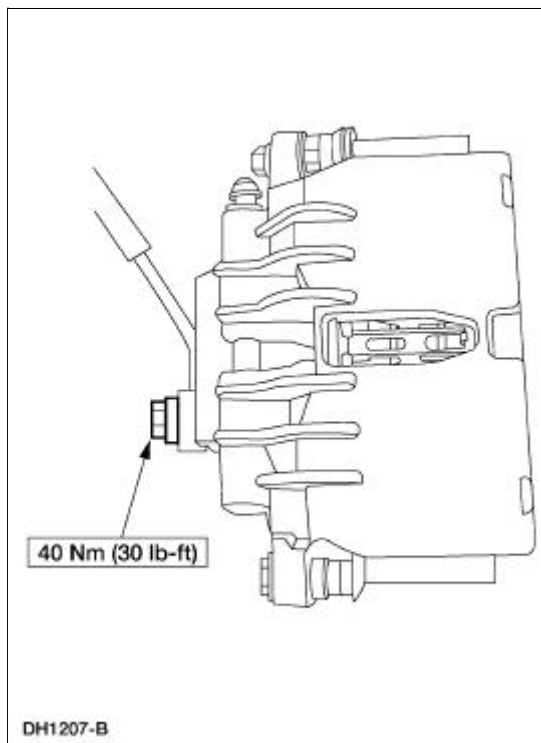

4. Bleed the caliper. For additional information, refer to [Section 206-00](#).
  5. Install the wheel and tire assembly. For additional information, refer to [Section 204-04](#).
  6. Fill the brake master cylinder reservoir (2K478) with clean High Performance DOT 3 Brake Fluid C6AZ-19542-AB or equivalent DOT 3 fluid meeting Ford specification ESA-M6C25-A. Install brake master cylinder filler cap (2162).
  7. Check the brake system operation.
-

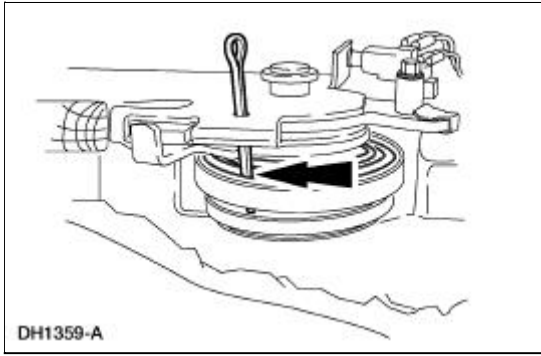

## Anti-Lock Control

The four wheel anti-lock brake system (4WABS) consists of the following components:

- anti-lock brake control module (2C346)
  - front anti-lock brake sensor (2C205)
  - front anti-lock brake sensor indicator (2C182)
  - hydraulic control unit (2C286)
  - rear anti-lock brake sensor (2C216)
  - rear anti-lock brake sensor indicator (2C189)
  - yellow anti-lock brake system (ABS) warning indicator
-

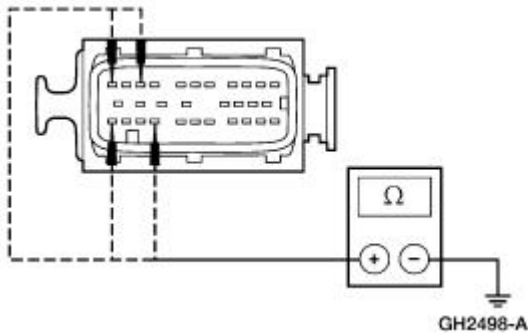

- Is the resistance greater than 10,000 ohms?

### F3 CHECK THE SUSPECT ANTI-LOCK BRAKE SENSOR FOR A SHORT TO GROUND

- Disconnect: Suspect Anti-Lock Brake Sensor.
- Measure the resistance between suspect anti-lock brake sensor Pin 1 (component side) and ground.

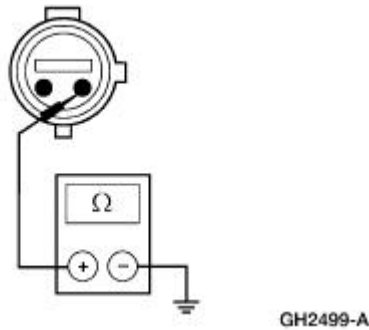

- Is the resistance greater than 10,000 ohms?

#### Yes

If RF, REPAIR Circuit 514 (YE/RD) and Circuit 516 (YE/BK), as necessary. CLEAR the DTCs. REPEAT the self-test. If LF, REPAIR Circuit 521 (TN/OG) and Circuit 522 (TN/BK), as necessary. CLEAR the DTCs. REPEAT the self-test. If RR, REPAIR Circuit 494 (TN/LG) and Circuit 492 (BN), as necessary. CLEAR the DTCs. REPEAT the self-test. If LR, REPAIR Circuit 496 (OG) and Circuit 499 (GY/BK), as necessary. CLEAR the DTCs. REPEAT the self-test.

#### No

INSTALL a new anti-lock brake sensor; REFER to [Sensor—Front](#) or [Sensor—Rear](#). CLEAR the DTCs. REPEAT the self-test.

### F4 CHECK THE SUSPECT ANTI-LOCK BRAKE SENSOR CIRCUIT FOR FOR AN OPEN

- Key in OFF position.
- Measure the resistance between anti-lock brake control module C141 Pins, harness side and suspect anti-lock brake sensor, harness side as follows:

DTC	Anti-Lock Brake Control Module	Anti-Lock Brake Sensor	Circuit
C1145 (RF)	C141 Pin 4	C145 Pin 1	514 (YE/RD)
C1145 (RF)	C141 Pin 5	C145 Pin 2	516 (YE/BK)
C1155 (LF)	C141 Pin 20	C144 Pin 1	521 (TN/OG)
C1155 (LF)	C141 Pin 21	C144 Pin 2	522 (TN/BK)
C1165 (RR)	C141 Pin 1	C319 Pin 2	494 (TN/LG)
C1165	C141 Pin 3	C319 Pin 1	492 (BN)

#### Yes

GO to [F5](#).

#### No

REPAIR the circuit in question. CLEAR the DTCs. REPEAT the self-test.

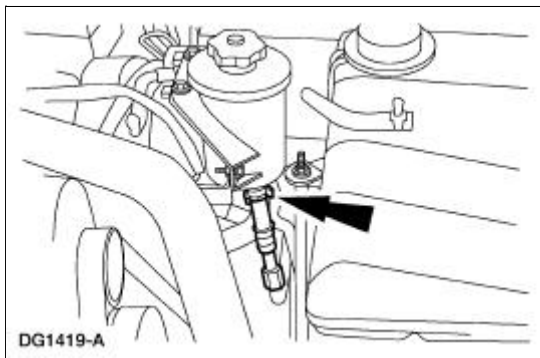

9.  **CAUTION: Do not overfill the reservoir.**

Check the fluid level. If necessary, fill the reservoir to the correct level.

- Use Motorcraft MERCON® Multi-Purpose ATF XT-2-QDX or MERCON® equivalent.

10. Install the fuel pump fuse.

11.  **CAUTION: Do not hold the steering wheel against the stops for more than three to five seconds at a time. Damage to the power steering pump will occur.**

Start the engine and turn the steering wheel from stop-to-stop.

12.  **CAUTION: Do not overfill the reservoir.**

**NOTE:** If the power steering system is noisy and is accompanied by evidence of aerated fluid it will be necessary to purge the power steering system.

Check the fluid level. If necessary, fill the reservoir to the correct level.

- Use Motorcraft MERCON® Multi-Purpose ATF XT-2-QDX or MERCON® equivalent.
-

### General Specifications

Item	Specification
<b>Lubricant</b>	
Ignition Lock Grease FOAZ-19584-A	ESA-M1C232-A

### Torque Specifications

Description	Nm	lb-ft	lb-in
Lock cylinder housing screws	22	17	—
Steering column lower bearing retainer bolts	9	—	80
Ignition switch screws	6	—	53
Multi-function switch screws	3	—	27
Steering wheel bolt	38	28	—
Steering column retaining nuts	15	12	—
Intermediate shaft coupler-to-steering column shaft bolt	25	19	—

---



---

## Camshaft Journal — Clearance, Push Rod Engines, Micrometer Method

1. **NOTE:** The camshaft journals must meet specifications before checking camshaft journal clearance.

Measure each camshaft bearing (6261) in two directions.

- Subtract the camshaft journal diameter from the camshaft bearing diameter.

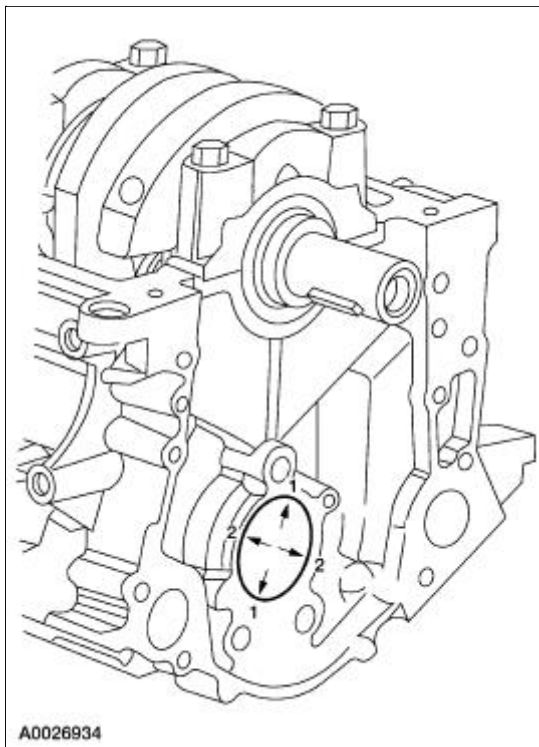

A0026934

---

---

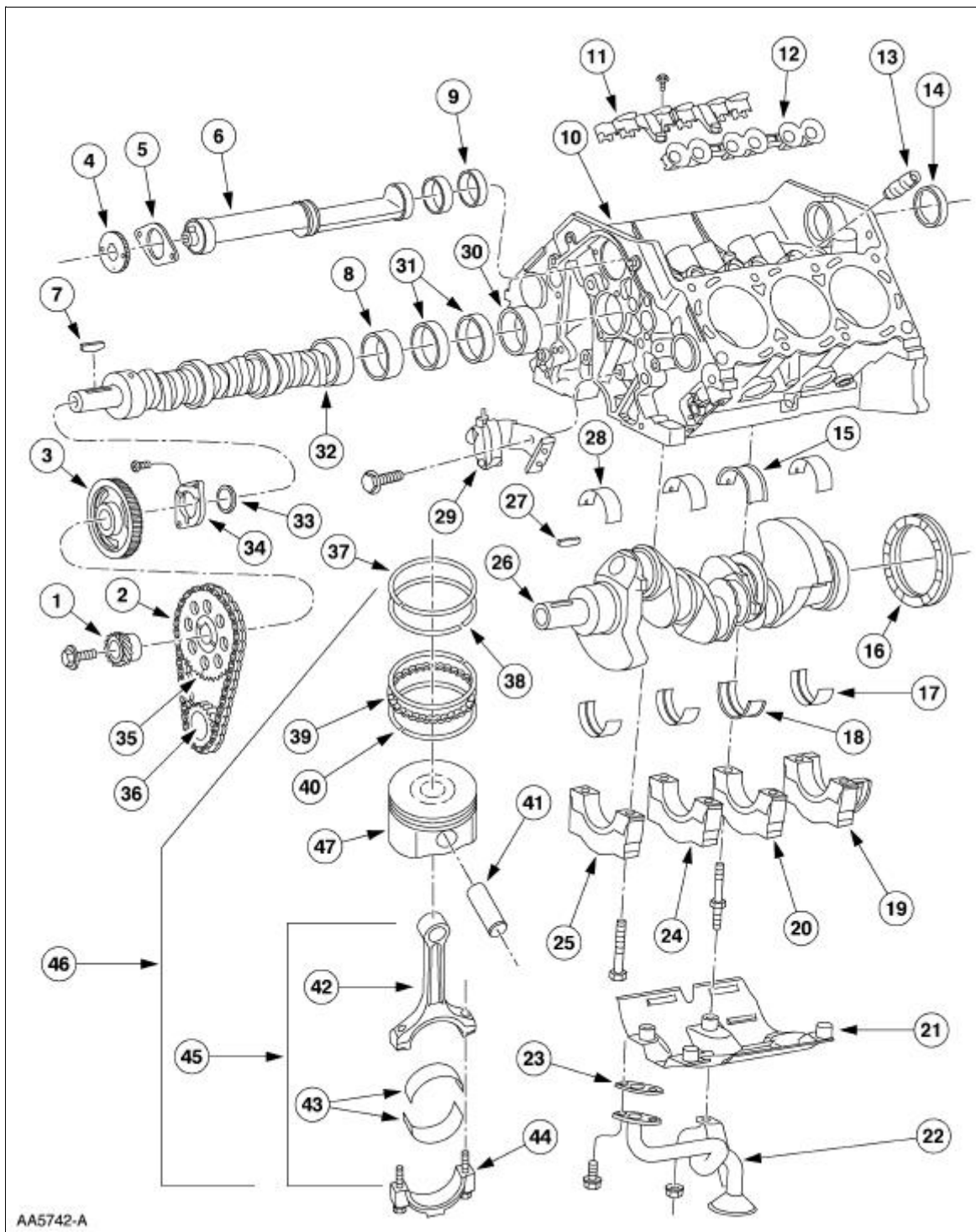

AA5742-A

Item	Part Number	Description
1	6255	Distributor drive gear
2	6268	Timing chain
3	6A303	Engine balance shaft drive gear
4	6A304	Engine balance shaft driven gear
5	6C341	Balance shaft thrust plate
6	6A311	Engine dynamic balance shaft
7	W705934	Woodruff key
8	6261	Camshaft bearing



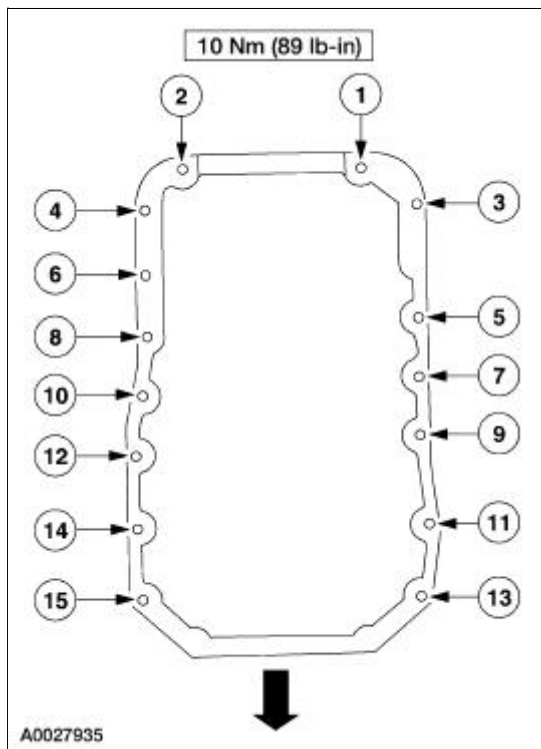

4. Install the transmission lower bolts.

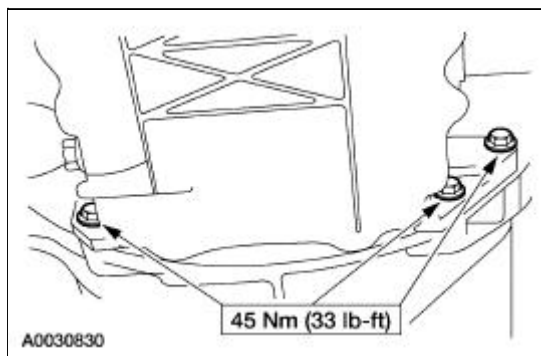

5. Install the oil pan drain plug.

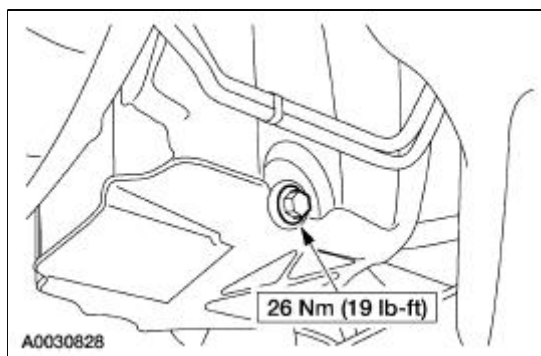

6. Raise the front subframe into position.

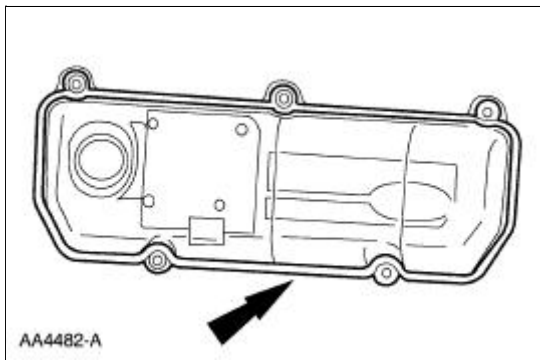

39. Remove the bolts and the oil pan.

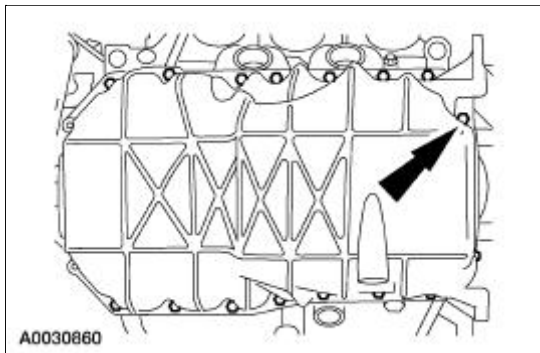

40.  **CAUTION:** If the components are to be reinstalled, they must be installed into the same position. Mark the components for location.

Remove the LH rocker arms.

1. Remove the bolts.
2. Remove the rocker arms.

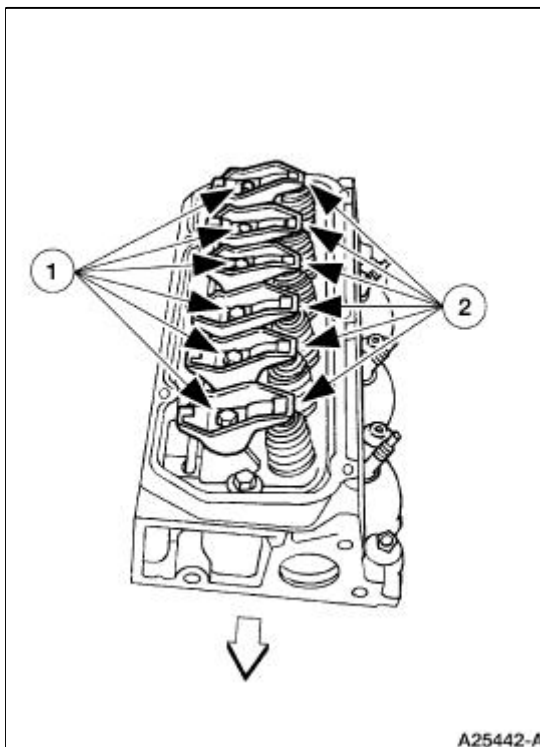

41. Remove the LH push rods.



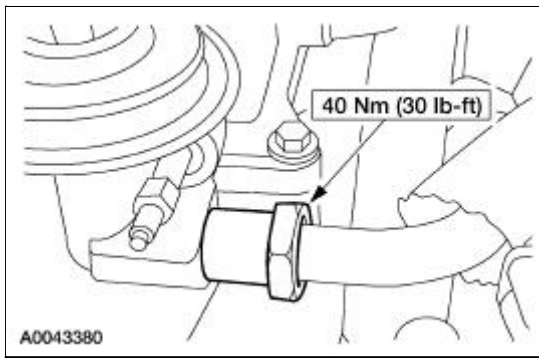

27. Install the EGR vacuum regulator solenoid bracket.

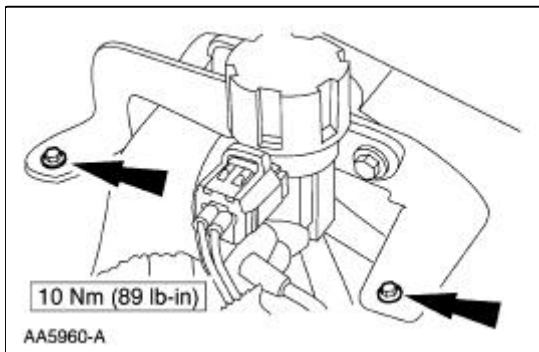

28. Connect the EGR vacuum regulator solenoid vacuum supply.

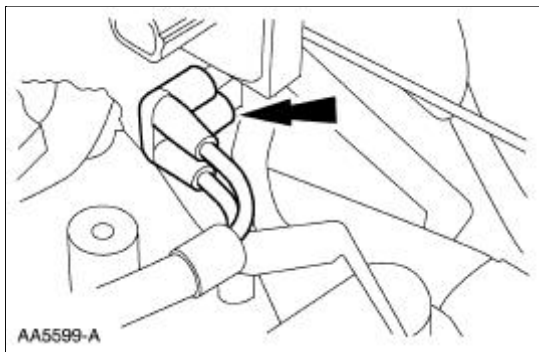

29. Connect the EGR vacuum regulator solenoid electrical connector.

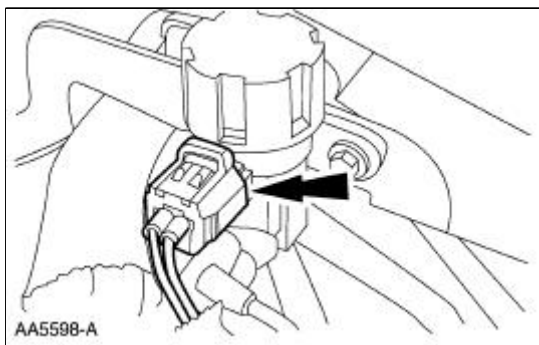

30. Connect the hoses to the differential pressure feedback EGR transducer.



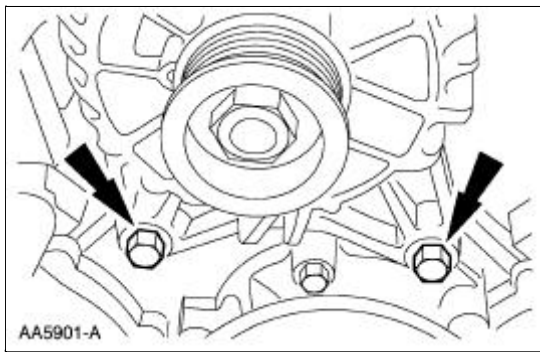

23. Remove the coolant outlet adapter.

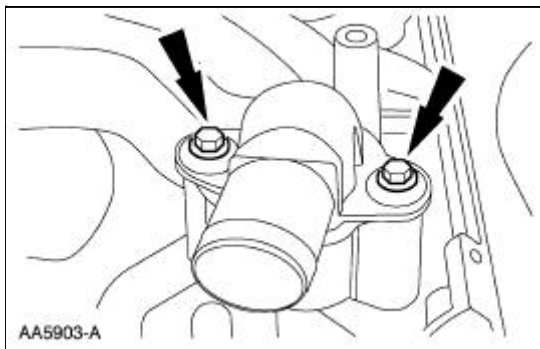

24. Remove the thermostat and O-ring.

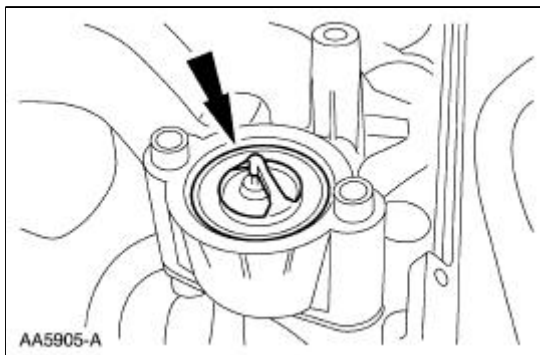

25. Remove the bolts in the sequence shown, and remove the intake manifold.

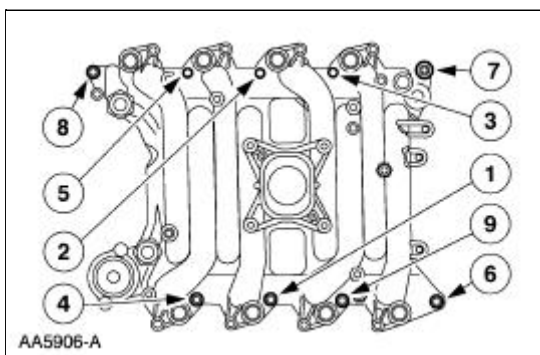

26. Remove the intake manifold gaskets.

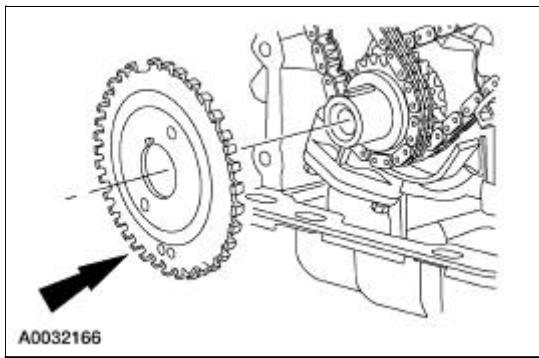

53. Remove the RH and LH timing chain tensioner (RH shown, LH similar).
1. Remove the bolts.
  2. Remove the timing chain tensioners.
  3. Remove the timing chain tensioner arms.

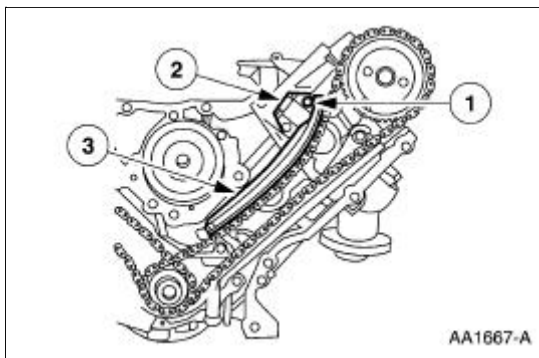

54. **⚠ CAUTION: Unless otherwise instructed, at no time when the timing chains are removed and the cylinder heads are installed is the crankshaft or the camshaft to be rotated. Severe piston and valve damage can occur.**

**⚠ CAUTION: Do not remove the special tool from the camshafts.**

Remove the LH and RH timing chains and the crankshaft sprocket.

- Remove the RH timing chain from the camshaft sprocket.
- Remove the RH timing chain from the crankshaft sprocket.
- Remove the LH timing chain from the camshaft sprocket.
- Remove the LH timing chain from the crankshaft sprocket.

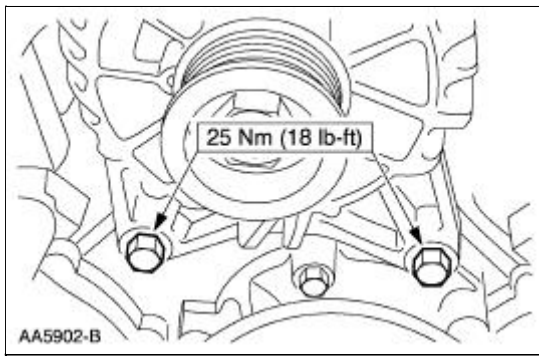

82. Install the generator support brace.

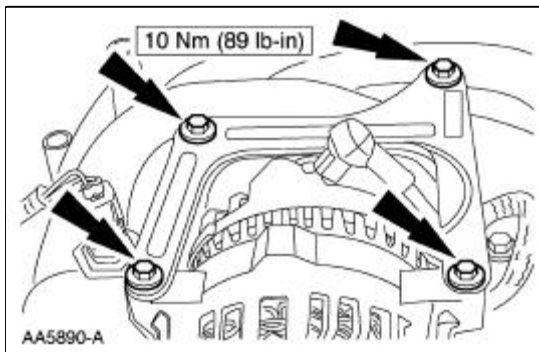

83. Install the accessory drive belt. For additional information, refer to [Section 303-05](#).

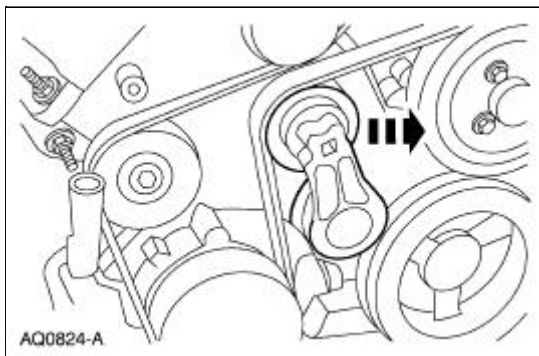

84. Install the radio interference capacitors.

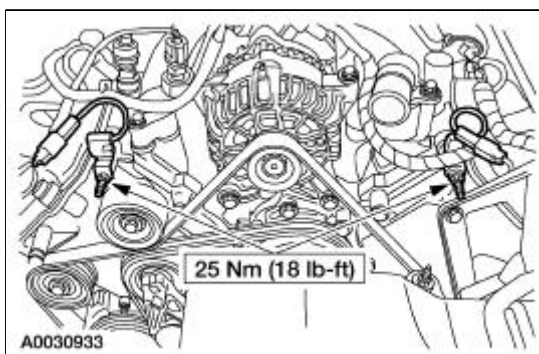

85. Install the ignition coils and bolts.

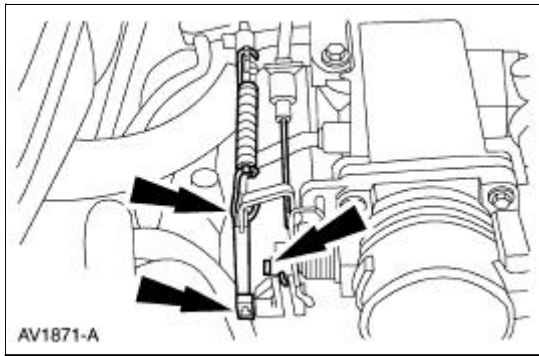

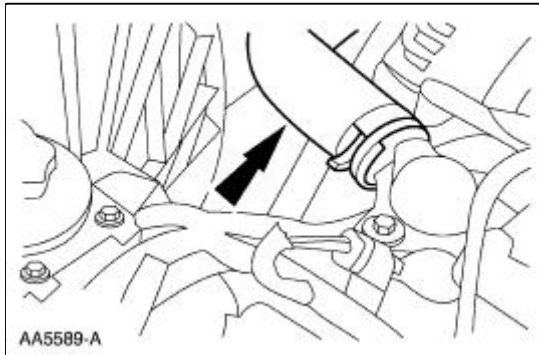

44. Connect the upper radiator hose from the water outlet adapter.



45. Connect the fuel lines. For additional information, refer to [Section 310-00](#).
  46. Install the battery. For additional information, refer to [Section 414-01](#).
  47. Install the air cleaner and outlet tube. For additional information, refer to [Section 303-12](#).
  48. Install the degas bottle. For additional information, refer to [Section 303-03A](#) or [Section 303-03B](#).
  49. Fill the fluids to the correct levels.
  50. Start the engine and check for leaks. Stop the engine and recheck the fluid levels.
  51. Recharge the A/C system. For additional information, refer to [Section 412-00](#).
  52. Install the hood.
-

## Crankshaft Pulley

### Special Tool(s)

 ST1286-A	Remover, Crankshaft Vibration Damper 303-009 (T58P-6316-D)
 ST1287-A	Installer, Crankshaft Vibration Damper 303-102 (T74P-6316-B)

### Material

Item	Specification
Silicone Gasket and Sealant F7AZ-19554-EA	WSE-M4G323-A4

### Removal

1. Remove the auxiliary crankshaft pulley. For additional information, refer to [Crankshaft Pulley—Auxiliary](#) in this section.
2. Remove the accessory drive belt. For additional information, refer to [Section 303-05](#).
3. Remove the bolt.

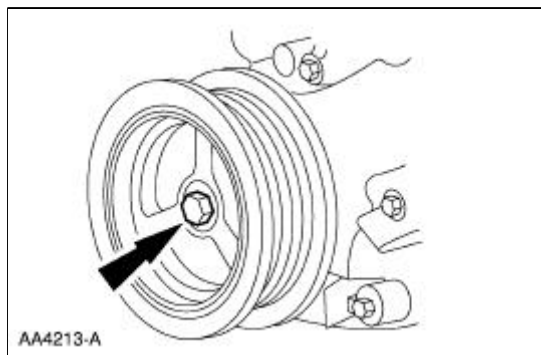

4. Using the special tool, remove the crankshaft pulley.



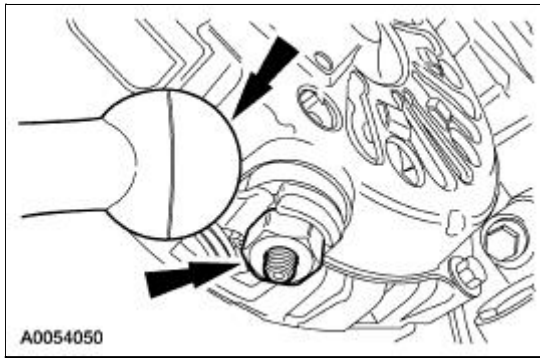

58. Remove the nut and the engine ground cable.

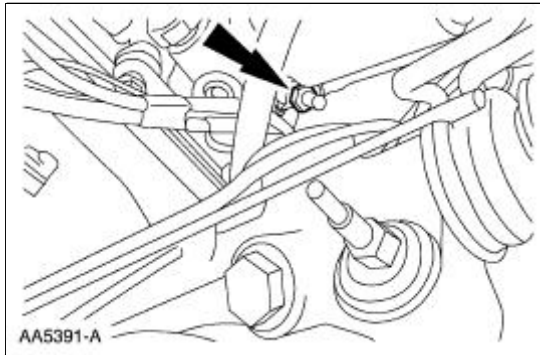

59. Disconnect the hose from the oil filter adapter.

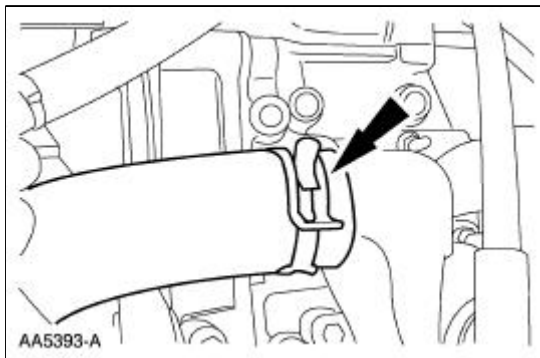

60. Disconnect and remove the lower hose from the radiator.

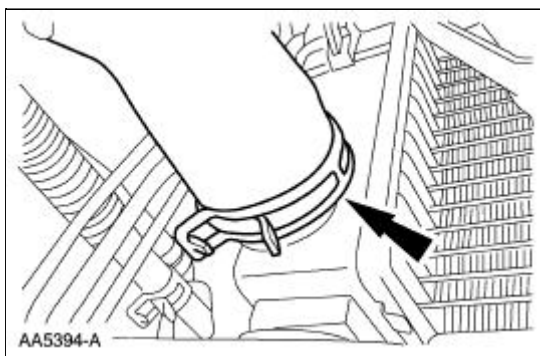

61. Remove the ground strap bolt.

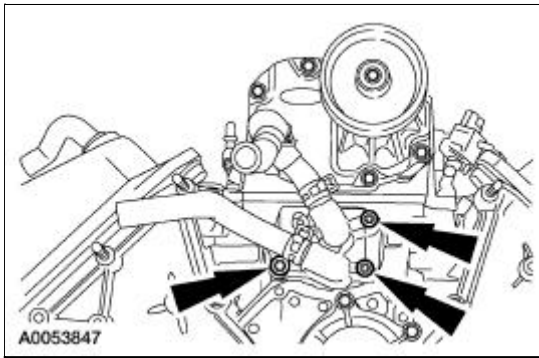

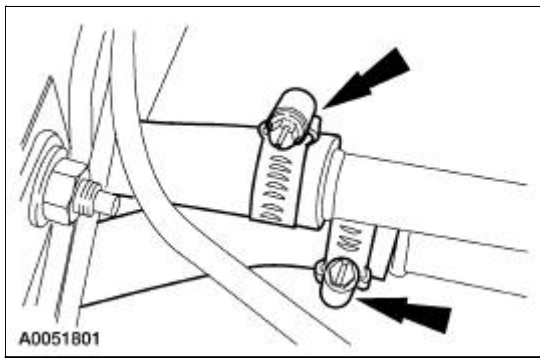

28. Connect the lower radiator hose to the coolant bypass tube.

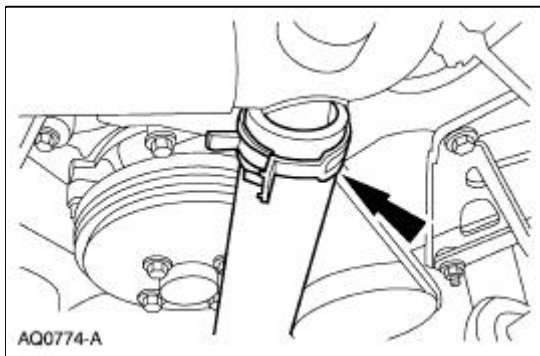

29. Install the supercharger degas bottle and the mounting bolts.

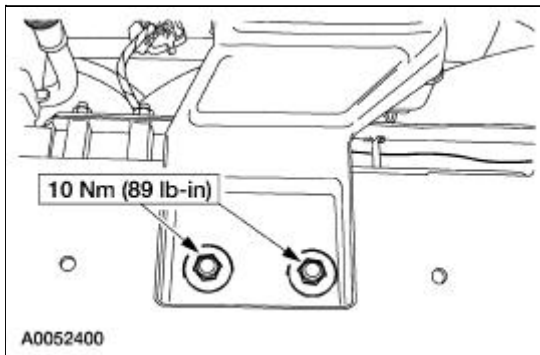

30. Connect the supercharger degas hose.

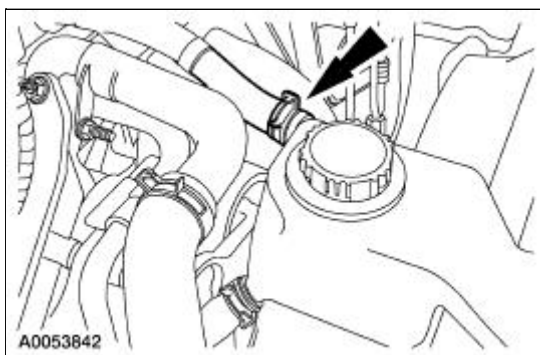

31. Install the power steering hose bracket and mounting nut.

## Valve Cover RH

### Material

Item	Specification
Metal Surface Cleaner F4AZ-19A536-RA or equivalent	WSE-M5B392-A
Silicone Gasket and Sealant F7AZ-19554-EA or equivalent	WSE-M4G323-A4
PAG Refrigerant Compressor Oil F7AZ-19589-DA (Motorcraft YN-12-C) or equivalent	WSH-M1C231-B

### Removal

1. Disconnect the battery ground cable. For additional information, refer to [Section 414-01](#).
2. Drain the cooling system. For additional information, refer to [Section 303-03A](#).
3. Recover the refrigerant. For additional information, refer to [Section 412-00](#).
4. Remove the air cleaner outlet tube. For additional information, refer to [Section 303-12](#).
5. Remove the RH ignition coil cover bolts and the cover.

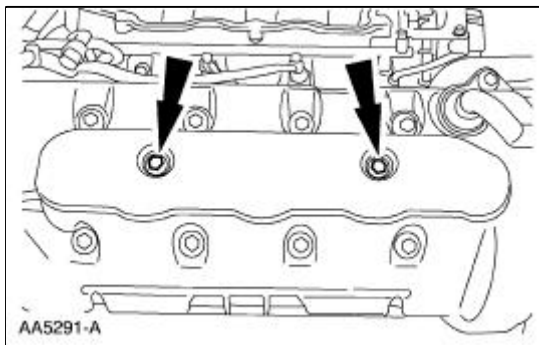

6. Disconnect the ignition coil electrical connectors.

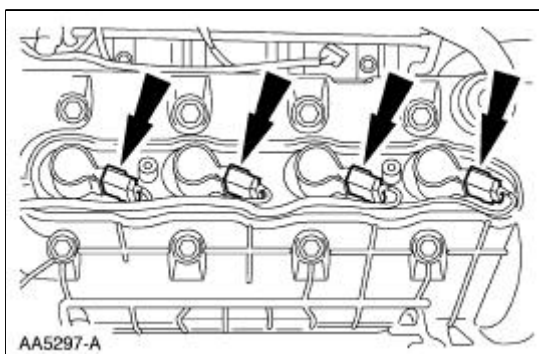



## Flexplate

1. Remove the transmission. For additional information, refer to [Section 307-01](#).
2. Remove the bolts in the sequence shown, and remove the flexplate.

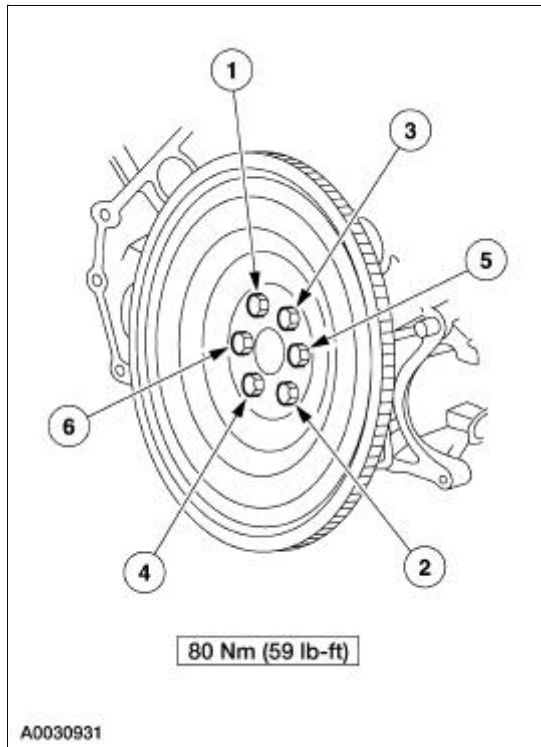

3. To install, reverse the removal procedure.

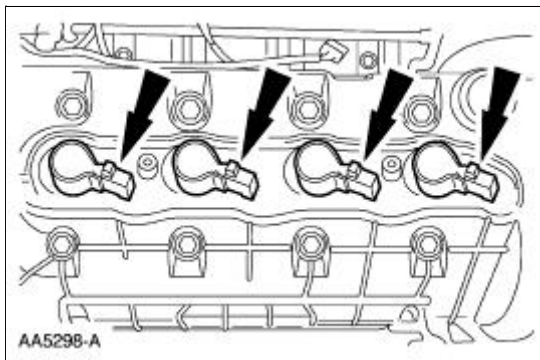

28. Remove the bracket from the accessory drive belt tensioner.
29. Remove the accessory drive belt.
30. Remove the coolant bypass tube and upper generator support bracket.
  - Remove the bolts.
  - Remove the coolant bypass tube.
  - Remove the upper generator support bracket.

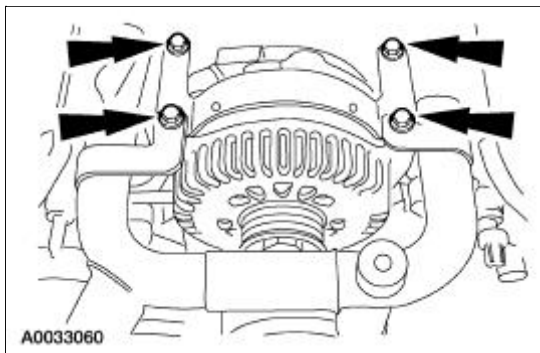

31. Remove the generator.

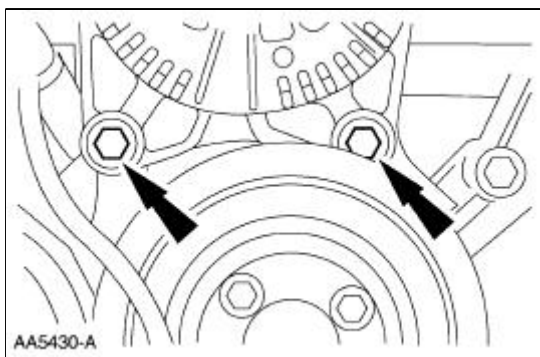

32. Remove the eight bolts and the two studs in the sequence shown. Remove the lower intake manifold.

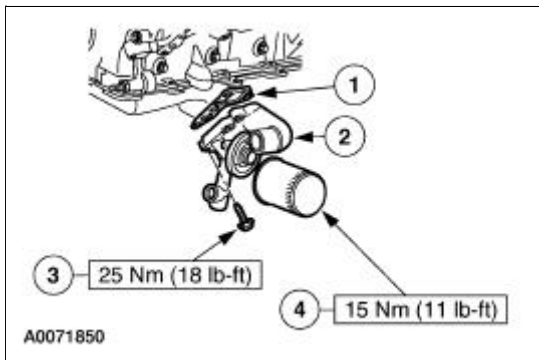

47. Using the special tool, install the 32 roller followers.

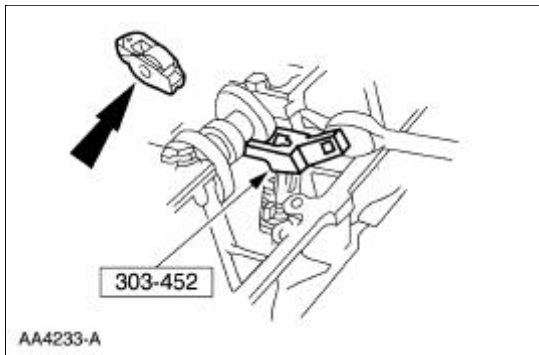

48. **NOTE:** If the valve cover is not secured within four minutes, the sealant must be removed and the sealing area cleaned with metal surface cleaner. Allow to dry until there is no sign of wetness, or four minutes, whichever is longer. Failure to follow this procedure can result in future oil leakage.

Apply silicone gasket and sealant in the locations shown.

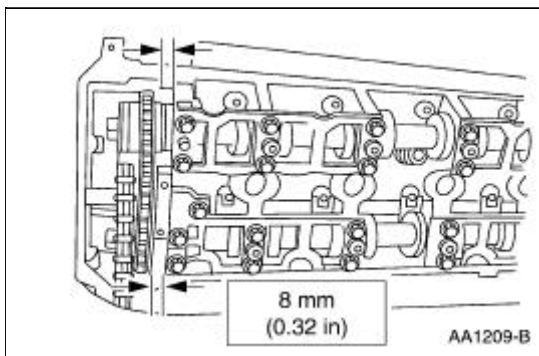

49. **NOTE:** The RH is shown; the LH is similar.

Install the valve covers and tighten the bolts in the sequence shown.

1. Turn the engine OFF.
2.  **WARNING:** Never remove the pressure relief cap while the engine is operating or when the cooling system is hot. Failure to follow these instructions can result in damage to the cooling system or engine or personal injury. To avoid having scalding hot coolant or steam blow out of the degas bottle when removing the pressure relief cap, wait until the engine is cooled, then wrap a thick cloth around the pressure relief cap and turn it slowly. Step back while the pressure is released from the cooling system. When you are sure all the pressure has been released, turn and remove the pressure relief cap (still with a cloth).

Check the engine coolant level; refer to [Cooling System Draining, Filling and Bleeding](#) in this section.

3. Connect Radiator Heater Core Pressure Tester to the degas bottle nipple and vent hose. Install a pressure test pump to the quick-connect fitting of the test adapter.
4.  **CAUTION:** Do not pressurize the cooling system beyond 152 kPa (22 psi).

**NOTE:** If the plunger of the pump is depressed too quickly, an erroneous pressure reading will result.

Slowly depress the plunger of the pressure test pump until the pressure gauge reading stops increasing and note the highest pressure reading obtained.

5. If the pressure relief cap does not hold pressure, remove and wash the pressure relief cap in clean water to dislodge all foreign particles from the gaskets. Check the sealing surface in the filler neck.
6. If 110 kPa (16 psi) cannot be reached, install a new pressure relief cap. If more than 124 kPa (18 psi) shows on gauge, install a new pressure relief cap.
7.  **CAUTION:** If the pressure drops, check for leaks at the engine-to-heater core hoses, engine-to-radiator hoses, water valve hose (if applicable), oil cooler return tube gasket (6N789), radiator and heater core or other system components and connections. Any leaks which are found must be corrected and the system rechecked.

Pressurize the engine cooling system as described in Step 4 (using a pressure relief cap that operates within the specified upper and lower pressure limits). Observe the gauge reading for approximately two minutes; refer to General Specifications. Pressure should not drop during this time.

8. Release the system pressure by loosening the pressure relief cap. Check the engine coolant level and replenish, if necessary, with the correct engine coolant mixture; refer to [Cooling System Draining, Filling and Bleeding](#) in this section.

### Cap — 3.8L

1. Inspect the radiator cap and seals for damage or deterioration. Install a new radiator cap if necessary.
2. Fit the radiator cap to Radiator/Heater Core Pressure Tester Kit, using the aftermarket adapter.
3. **NOTE:** If the plunger of the pressure tester is depressed too fast, an incorrect pressure reading will result.

Slowly pump the pressure tester until the pressure gauge stops increasing and note the highest

## Water Bypass Hose —3.8L

### Removal and Installation

1. Drain the engine coolant. For additional information, refer to [Cooling System Draining, Filling and Bleeding](#) in this section.
2. Remove the bypass hose.

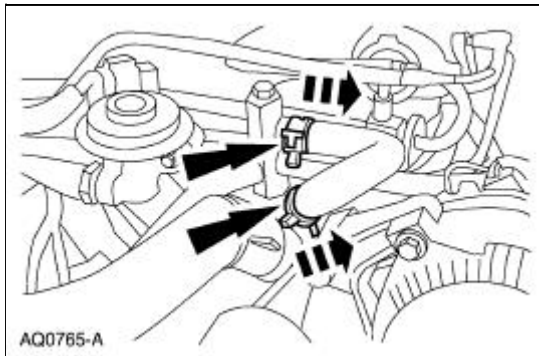

3. To install, reverse the removal procedure.
  4. Fill and bleed the cooling system. For additional information, refer to [Cooling System Draining, Filling and Bleeding](#) in this section.
-

12	—	Coolant reservoir bottle electrical connector
13	—	Radio ignition interference capacitor electrical connector
14	—	Fuel injector electrical connectors
15	—	Exhaust vacuum regulator (EVR) electrical connector
16	—	Differential pressure feedback EGR electrical connector
17	—	RH ignition coil electrical connectors
18	—	Ignition coil electrical connectors
19	—	Throttle position (TP) sensor electrical connector
20	—	Idle air control (IAC) solenoid electrical connector
21	—	Voltage regulator electrical connector
22	—	Engine coolant temperature (ECT) electrical connector
23	—	Generator battery electrical connector
24	—	Radio ignition interference capacitor electrical connector
25	—	Crankshaft position (CKP) sensor electrical connector
26	—	Air conditioning compressor clutch electrical connector
27	—	16 pin electrical connector

---

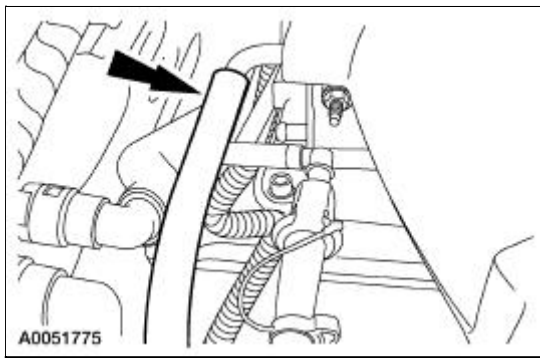

8. Disconnect the fuel pulse damper electrical connector and the vacuum hose.

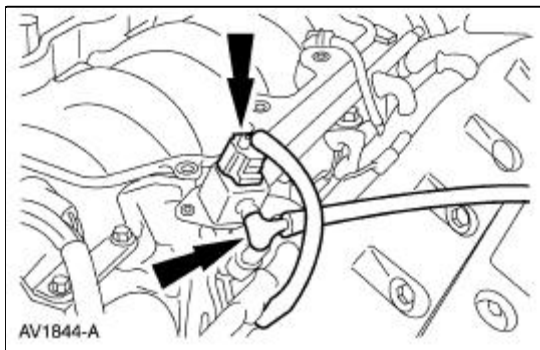

9. **NOTE:** RH shown, LH similar.

Disconnect the eight fuel injector electrical connectors.

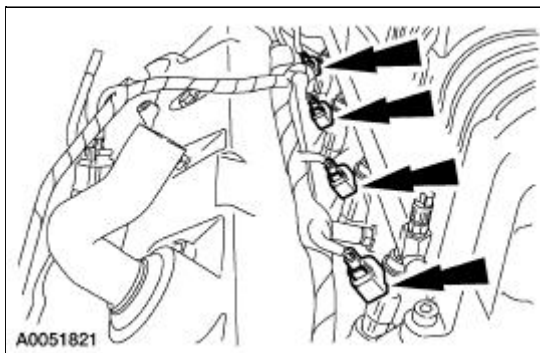

10. Separate the fuel charging wiring harness from the fuel injection supply manifold in four places.

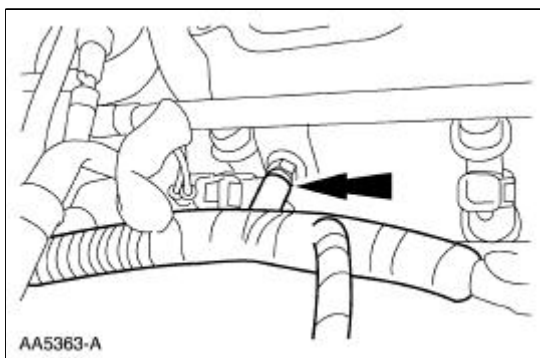

11. Remove the fuel supply manifold mounting studs.

## Accessory Drive Belt Tensioner —3.8L

### Removal and Installation

1. Remove the drive belt. For additional information, refer to [Accessory Drive Belt—3.8L](#) in this section.
2. Remove the belt tensioner.
  - Remove the bolt.

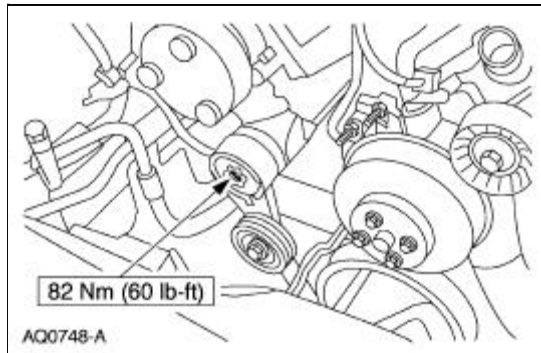

3. To install, reverse the removal procedure.
-

## Spark Plugs

### Special Tool(s)

 ST1394-A	Remover, Spark Plug Wire 303-106 (T74P-6666A)
---	--

### Material

Item	Specification
Silicone Brake Caliper Grease and Dielectric Compound D7AZ-19A331-A or equivalent	ESE-M1C171-A

### Removal and Installation

 **CAUTION:** It is important to twist the spark plug wire boots while pulling upward to avoid possible damage to the spark plug wire.

 **CAUTION:** Spark plug wires must be connected to the correct ignition coil terminal. Mark spark plug wire (12286) locations before removing them.

1. Remove the air cleaner outlet pipe. For additional information, refer to [Section 303-12](#).
2. Using the special tool, remove the spark plug wires from the spark plugs using a twisting motion.
3. **NOTE:** Use compressed air to remove any foreign material from the spark plug well before removing the spark plugs.

**NOTE:** If an original spark plug is reused, make sure it is installed in the same cylinder from which it was taken. New spark plugs can be used in any cylinder.

**NOTE:** Left side shown, right side similar.

Remove the spark plugs.

## Exhaust Gas Recirculation (EGR) Vacuum Regulator Solenoid

### Mach I vehicles

1. Remove the air intake scoop. For additional information, refer to [Section 303-12](#).

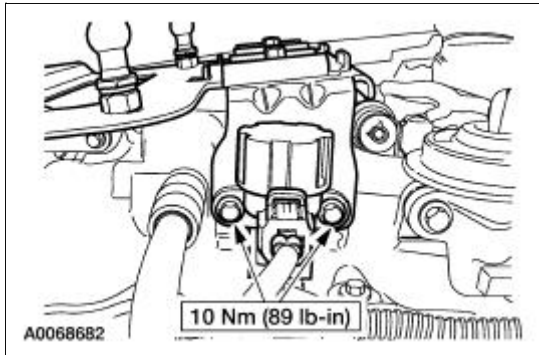

### All vehicles

2. Remove the exhaust gas recirculation (EGR) vacuum regulator solenoid.
    - Disconnect the electrical connector.
    - Remove the bolts.
  3. To install, reverse the removal procedure.
-

CLICK HERE TO **DOWNLOAD** THE COMPLETE MANUAL

- Thank you very much for reading the preview of the manual.
- You can download the complete manual from: [www.heydownloads.com](http://www.heydownloads.com) by clicking the link below



- Please note: If there is no response to CLICKING the link, please download this PDF first and then click on it.

CLICK HERE TO **DOWNLOAD** THE COMPLETE MANUAL

- EVAP lines or hoses
- Vacuum lines or hoses

- If the concern remains after the inspection, connect the scan tool to the data link connector (DLC) located beneath the instrument panel and select the vehicle to be tested from the scan tool menu. If the scan tool does not communicate with the vehicle:
  - check that the program card is correctly installed.
  - check the connections to the vehicle.
  - check the ignition switch position.
- If the scan tool still does not communicate with the vehicle, refer to the scan tool manual.
- Carry out the DATA LINK DIAGNOSTICS test. If the scan tool responds with:
  - CKT914, CKT915 or CKT70 = ALL ECUS NO RESP/NOT EQUIP, refer to [Section 418-00](#).
  - NO RESP/NOT EQUIP for PCM, refer to the Powertrain Control/Emissions Diagnosis (PC/ED) manual.
  - SYSTEM PASSED, retrieve and record the continuous diagnostic trouble codes (DTCs), erase the continuous DTCs and carry out the PCM KOEO self-test.
- If the DTCs retrieved are related to the concern, go to the PCM Diagnostic Trouble Code (DTC) Index to continue diagnostics.
- If the concern remains after the inspection, determine the symptom. GO to [Symptom Chart](#).

#### PCM Diagnostics Trouble Code (DTC) Index

DTC	Description	Source	Action
P0442	Small leak detected in EVAP system (As small as 1.02 mm [0.040 inch])	PCM	<a href="#">Go To Pinpoint Test A</a> .
P0455	Major leak or no flow detected	PCM	<a href="#">Go To Pinpoint Test B</a> .
P0457	Check for missing or leaking fuel filter cap	PCM	<a href="#">Go To Pinpoint Test A</a> .
P1443	Very small or no purge flow detected	PCM	<a href="#">Go To Pinpoint Test B</a> .
P1450	Excessive vacuum detected in the fuel tank	PCM	<a href="#">Go To Pinpoint Test C</a> .
—	Any other PCM DTC	PCM	REFER to the Powertrain Control/Emissions Diagnosis (PC/ED) manual.

#### Symptom Chart

##### SYMPTOM CHART

Condition	Possible Sources	Action
<ul style="list-style-type: none"> <li>● Hissing sound when removing fuel cap</li> </ul>	<ul style="list-style-type: none"> <li>● Canister vent solenoid.</li> <li>● Evaporative emissions canister.</li> <li>● Fuel vapor control valve</li> </ul>	<ul style="list-style-type: none"> <li>● <a href="#">Go To Pinpoint Test D</a>.</li> </ul>

## Electronic Engine Controls

The electronic engine controls consist of the following:

- powertrain control module (PCM)
- throttle position (TP) sensor
- idle air control (IAC) valve
- engine coolant temperature (ECT) sensor
- cylinder head temperature sensor
- camshaft position (CMP) sensor
- crankshaft position (CKP) sensor
- mass air flow (MAF) sensor
- intake air temperature (IAT) sensor
- heated oxygen sensor (HO2S) — front
- catalyst monitor sensor — rear
- wheel speed sensor

The powertrain control module needs the following inputs to calibrate the engine correctly:

- crankshaft position
- engine rpm
- engine load (manifold pressure)
- atmospheric (barometric) pressure
- engine coolant temperature

The throttle position sensor:

- sends the powertrain control module a signal indicating the throttle plate angle.
- is the main input to the powertrain control module from the driver.

The idle air control valve:

- controls bypass air around the throttle plate at low speeds.
- is controlled by the powertrain control module.

The cylinder head temperature sensor:

- provides a gauge signal for coolant temperature.
- is mounted on rear of LH cylinder head.
- sends the powertrain control module a signal indicating engine temperature.
- resistance decreases as coolant temperature increases.



4	7D020	Reverse clutch cylinder seal (2 req'd)
5	7C099	Direct clutch piston inner seal
6	7D019	Forward clutch cylinder
7	7A548	Direct clutch piston outer seal
8	7F274	Output shaft to direct clutch cylinder seal (2 req'd)
9	87054-S94	O-ring seal (piloted) (model dependent)
10	7086	Extension gasket
11	7052	Extension housing seal assembly
12	7C155	Control valve body upper gasket
13	7D100	Valve body separator plate lower gasket
14	7H173	Valve body cover plate gasket
15	7A191	Transmission pan to case gasket
16	7F273	Output shaft to case seal (3 req'd)
17	7B497	Input shaft seal (2 req'd)
18	7C099	Forward clutch piston inner seal
19	7A548	Forward clutch piston outer seal
20	7B498	Manual control lever seal assembly
21	7D403	Reverse clutch piston outer seal
22	7D404	Reverse clutch piston inner seal
23	7F224	Intermediate clutch piston outer seal
24	7F225	Intermediate clutch piston inner seal
25	391308-S	Fill tube level indicator seal
26	7Z484	TCC solenoid seal (large)
27	7Z136	TCC solenoid seal (small)
28	7Z484	Shift solenoid seal (2 req'd)
29	N811757-S100	Output shaft speed sensor seal
30	7Z276	Bulkhead seal (1 req'd)
31	N805862-S	Pressure control solenoid seal (large)
32	391131	Pressure control solenoid seal (small)

---

- Select "XXX" to cancel at any time.
- Press "SEND."

### **EPC in BENCH MODE**

The BENCH MODE is also used to test the functionality of the transmission's electronic pressure control. During BENCH MODE, the electronic pressure control (EPC) solenoid can ramp up/down in increments of 103 kPa (15 psi) from zero to 620 kPa (90 psi) and 620 kPa (90 psi) to zero psi.

The OSC functions for the parameter EPC allows the technician to choose the following options:

- EPC - activates EPC to selected values.
- 00 - sets EPC pressure to 00 kPa (00 psi).
- 15 - sets EPC pressure to 103 kPa (15 psi).
- 30 - sets EPC pressure to 206 kPa (30 psi).
- 45 - sets EPC pressure to 310 kPa (45 psi).
- 60 - sets EPC pressure to 411 kPa (60 psi).
- 75 - sets EPC pressure to 517 kPa (75 psi).
- 90 - sets EPC pressure to 620 kPa (90 psi).

To carry out an EPC BENCH MODE pressure functionality test, install a pressure gauge in the EPC port. The following requirements are required to carry out this test:

- VSS and digital TR sensor operational
- No VSS and digital TR sensor DTCs
- Transmission range selector lever in P
- Key ON
- Engine ON
- Engine speed at least 1,500 rpm for accurate EPC pressure measurement

To carry out an EPC BENCH MODE solenoid circuit pinpoint test, the following requirements are required.

- VSS and digital TR sensor operational
- No VSS and digital TR sensor DTCs
- Transmission range selector lever in P
- Key ON
- Engine OFF

### **OSC Command Values**

- 00 - sets EPC pressure to 00 kPa (00 psi).
- 15 - sets EPC pressure to 103 kPa (15 psi).
- 30 - sets EPC pressure to 206 kPa (30 psi).
- 45 - sets EPC pressure to 310 kPa (45 psi).
- 60 - sets EPC pressure to 411 kPa (60 psi).

## Special Testing Procedures

The special tests are designed to aid the technician in diagnosing the hydraulic and mechanical portion of the transmission.

### Engine Idle Speed Check

Refer to the Powertrain Control/Emissions Diagnosis (PC/ED) manual for diagnosis and testing of the engine idle speed.

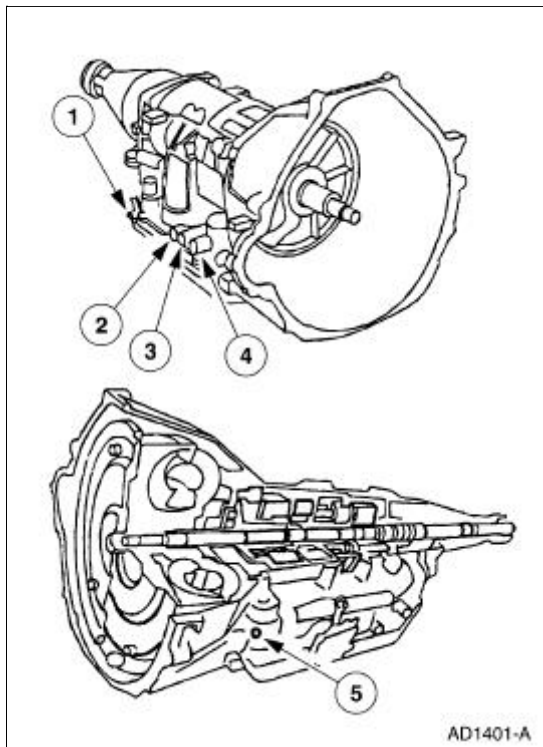

Item	Part Number	Description
1	—	Direct clutch pressure tap
2	—	Forward clutch pressure tap
3	—	Electronic pressure control (EPC) pressure tap
4	—	Intermediate clutch pressure tap
5	—	Line pressure tap

### Line Pressure Test

**⚠ CAUTION:** Carry out the line pressure test prior to carrying out the stall speed test. If the line pressure is low at stall, do not carry out stall speed test or further transmission damage will occur. Do not maintain WOT in any transmission range for more than five seconds.

This test verifies that the line pressure is within specification.

1. Connect pressure gauge to line pressure tap.

<b>Shift Linkage, Digital TR Sensor</b>	<ul style="list-style-type: none"> <li>Inspect and repair as required. Verify transmission shift cable adjustment; refer to <a href="#">Section 307-05</a>. Adjust transmission shift cable as necessary. After repairing transmission shift cable, verify that the digital TR sensor is correctly adjusted. Adjust the digital TR sensor as necessary.</li> </ul>
<ul style="list-style-type: none"> <li>Damaged or incorrectly adjusted</li> </ul>	
<b>Park Mechanism</b>	<ul style="list-style-type: none"> <li>Inspect for damage or incorrect assembly and repair as required.</li> </ul>
<ul style="list-style-type: none"> <li>Output shaft ring, parking brake pawl, parking pawl return spring, park rod guide cup, parking pawl shaft, parking pawl actuating rod, manual lever detent spring damaged or assembled incorrectly</li> </ul>	

### Other Concerns: Overheating

Possible Component	Reference/Action
<b>257 — ELECTRICAL ROUTINE</b>	
Refer to Routine 240/340, Torque Converter Operation Concern: No Apply	
<b>357 — HYDRAULIC/MECHANICAL ROUTINE</b>	
<b>Fluid</b>	
<ul style="list-style-type: none"> <li>Incorrect level</li> </ul>	<ul style="list-style-type: none"> <li>Adjust fluid to correct level.</li> </ul>
<ul style="list-style-type: none"> <li>Condition</li> </ul>	<ul style="list-style-type: none"> <li>Inspect condition of fluid.</li> </ul>
<b>Other</b>	
<ul style="list-style-type: none"> <li>Damaged, blocked or reversed cooler lines or restriction in the transmission oil cooler</li> </ul>	<ul style="list-style-type: none"> <li>Inspect for damage and correct installation. Repair as required.</li> </ul>
<b>Vehicle Concerns Causing Engine Overheating</b>	
	<ul style="list-style-type: none"> <li>Refer to the appropriate engine cooling section.</li> </ul>
<b>Main Controls</b>	
<ul style="list-style-type: none"> <li>Drain back valve, torque clutch control valve, converter limit valve stuck, damaged or assembled incorrectly</li> </ul>	<ul style="list-style-type: none"> <li>Inspect for damage and repair as required.</li> </ul>
<b>Torque Converter Clutch</b>	
<ul style="list-style-type: none"> <li>No apply</li> </ul>	<ul style="list-style-type: none"> <li>Refer to Routine 240/340.</li> </ul>

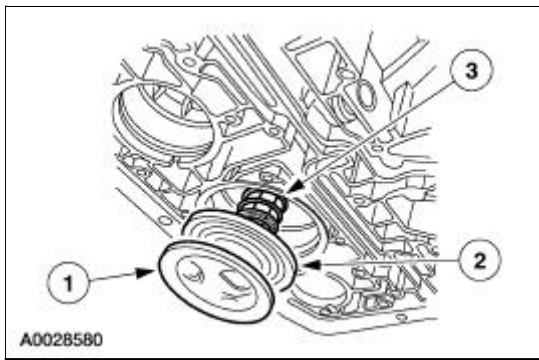

## Installation

**NOTE:** This is not an ordinary installation procedure and does not compensate for band wear.

1. **NOTE:** Lubricate the reverse piston seal to facilitate assembly and prevent damage to the seal.

Install the reverse servo return spring and piston.

- Do not install the piston cover.

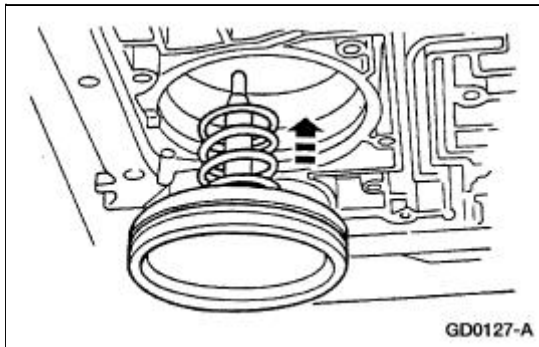

2. Install the special tool and tighten the band apply bolt.

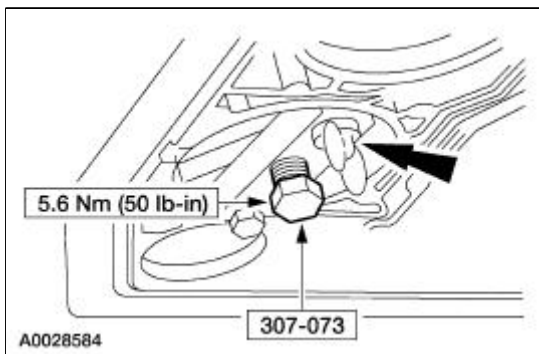



3. Attach the special tool to the transmission.

- Position the indicator stem on the flat portion of the reverse servo piston and zero the dial indicator.

## Pump and Intermediate Clutch Piston

### Special Tool(s)

 <p>ST1189-A</p>	Installer, Front Pump Fluid Seal 307-014 (T63L-77837-A)
 <p>ST1914-A</p>	Protector, Piston Seal 307-339 (T95L-77005-A)

### Pump and Intermediate Clutch Piston — Disassembled View

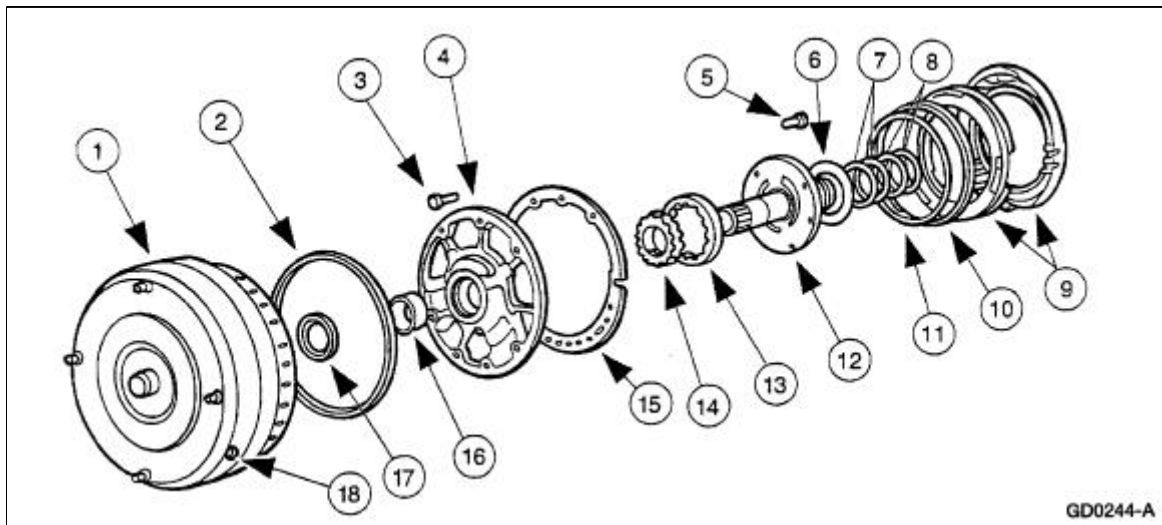

GD0244-A

Item	Part Number	Description
1	7902	Torque converter
2	7A248	Front pump O-ring
3	N605789-S101	Bolt
4	—	Pump body assembly
5	N605787-S1000	Front pump support bolt
6	7D014	No. 1 pump support thrust washer
7	7D020	Reverse clutch cylinder seal
8	7D019	Forward clutch cylinder seal
9	7E005	Intermediate clutch piston
10	7F224	Intermediate clutch piston outer seal

---

## Torque Converter Cleaning And Inspection

### Material

Item	Specification
MERCON® V Automatic Transmission Fluid XT-5-QM, XT-5-DM	MERCON® V

1. If a new torque converter is being installed, continue with Substep 2 of Step 2.
  2. If a new torque converter is not being installed, the following procedures must be performed:
    1. The torque converter must be thoroughly cleaned.
      - Torque converters with drain plugs can be cleaned by using a suitable torque converter/fluid cooler cleaner.
      - Torque converters without drain plugs can be cleaned by hand. Partially fill the torque converter using only recommended transmission fluid for the applicable transmission. Hand agitate the torque converter and then thoroughly drain the fluid. Refill the torque converter with clean automatic transmission fluid specified for transmission, and reinstall.
    2. All in-tank and auxiliary coolers must be thoroughly cleaned by forward and backward flushing. For additional information, refer to [Transmission Fluid Cooler — Backflushing and Cleaning](#) in this section.
    3. All cooler lines must be thoroughly cleaned by backward and forward flushing. For additional information, refer to [Transmission Fluid Cooler — Backflushing and Cleaning](#) in this section.
    4. All Cooler Bypass Valves (CBV), if equipped, must be thoroughly cleaned.
    5. Carry out the Transmission Fluid Cooler Flow Test. For additional information, refer to [Transmission Fluid Cooler — Backflushing and Cleaning](#) in this section.
    6. If the transmission cooling system fails the Transmission Fluid Cooler Flow Test, a new fluid cooler, cooler bypass valve, and/or cooler lines must be installed. For additional information, refer to [Section 307-02](#).
    7. If new coolers are to be installed, use only factory approved service parts.
-

15. Install the cover.

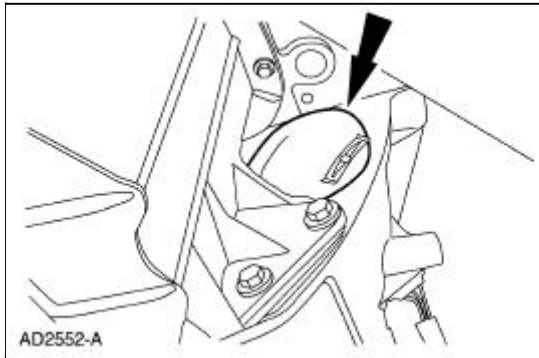

16. Reconnect the connector.

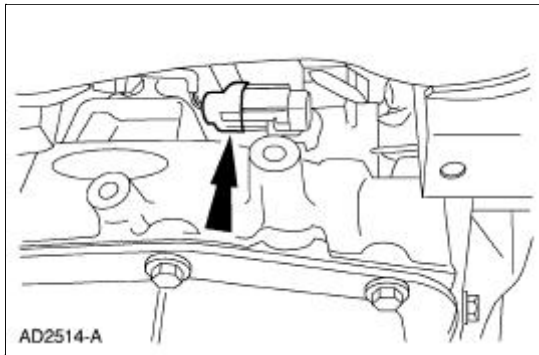

17. Reconnect the connector.

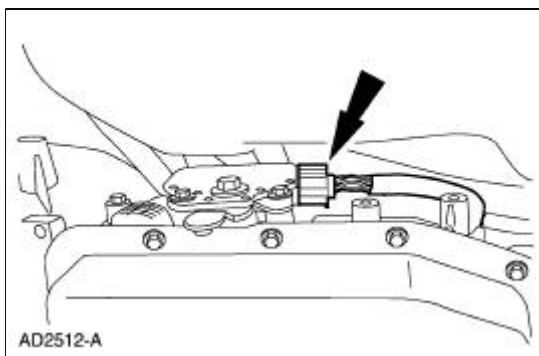

18. Install the dual converter Y pipe.

19. **NOTE:** The output shaft and the drive shaft are a balanced assembly.

Install the driveshaft.

- Align the yellow dots and position the driveshaft on the transmission.
- Position the driveshaft to the rear differential.

## **Installation**

1. To install, reverse the removal procedure.
-

## Pilot Bearing

### Special Tool(s)

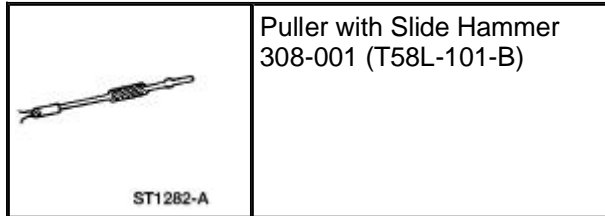

1. Remove the clutch disc and the clutch pressure plate. For additional information, refer to [Disc and Pressure Plate—3.8L and 4.6L \(2V\) Engines](#) or [Disc and Pressure Plate—4.6L \(4V\) Engine](#) in this section.
2. Using the special tool, remove the pilot bearing from the flywheel.

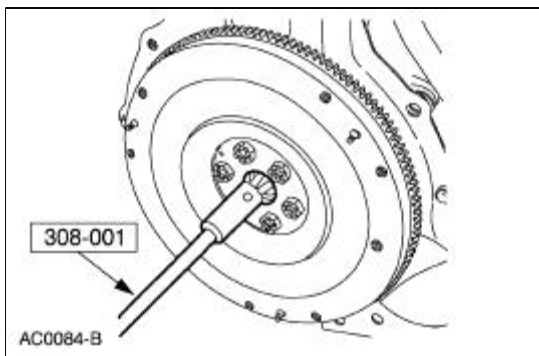

### Installation

1. Insert the pilot bearing into the crankshaft.

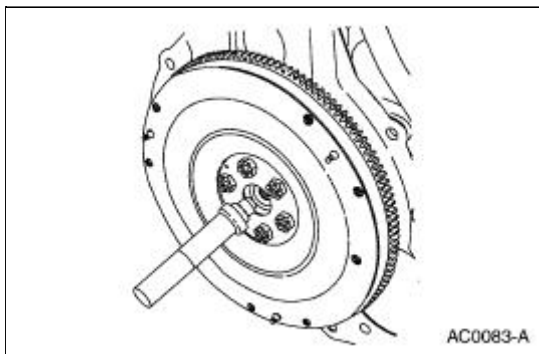

2. Install the clutch disc and the clutch pressure plate. For additional information, refer to [Disc and Pressure Plate—3.8L and 4.6L \(2V\) Engines](#) or [Disc and Pressure Plate—4.6L \(4V\) Engine](#) in this section.

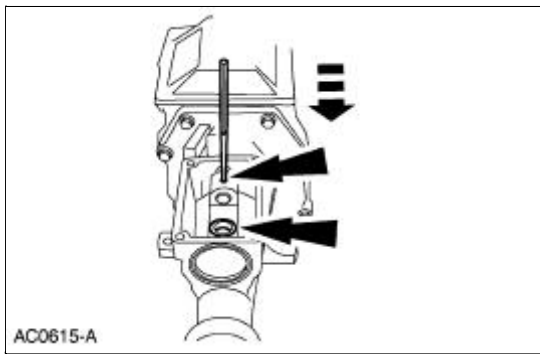

- Using the special tools, remove the extension housing fluid seal.

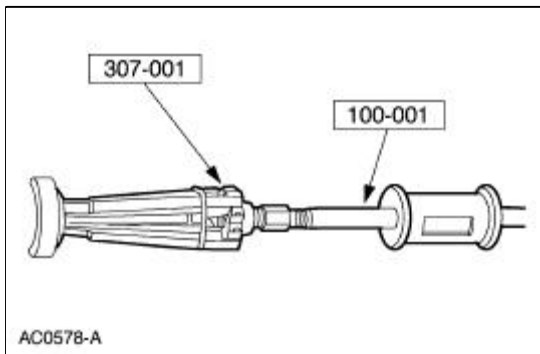

- Remove the seven bolts and the identification tag.

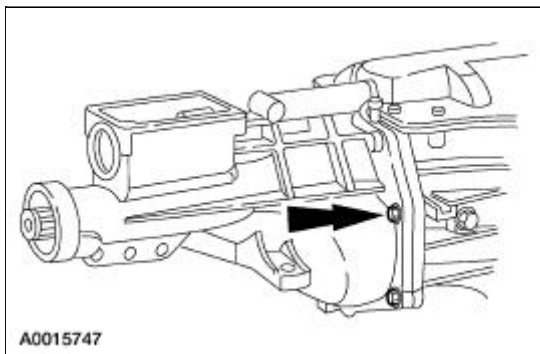

- ⚠ CAUTION: The gearshift offset lever is under spring pressure.**

While applying downward pressure on the gearshift offset lever, remove the extension housing and the gearshift offset lever as an assembly.

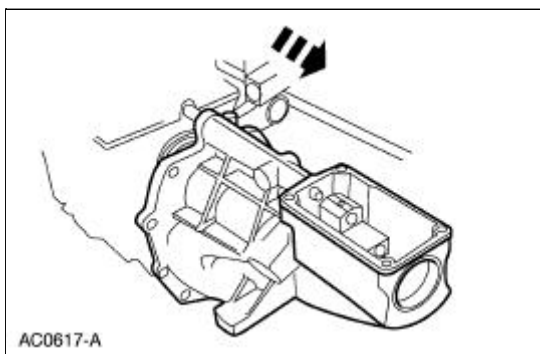

- Remove the gearshift offset lever, the split pin, the shifter detent spring, and the detent ball.

38. Apply a 3.2-mm (1/8-inch) bead of silicone rubber to the sealing surface on the gearshift lever.
39. Install the gearshift lever.

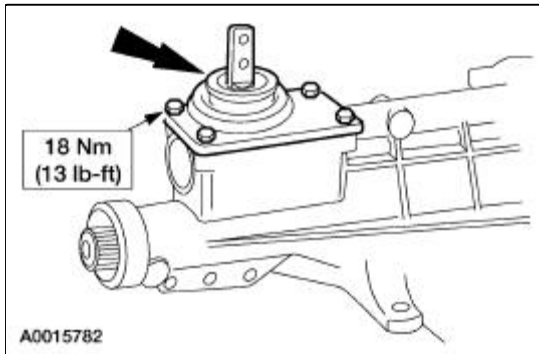

40. Using the special tool, install the extension housing fluid seal.

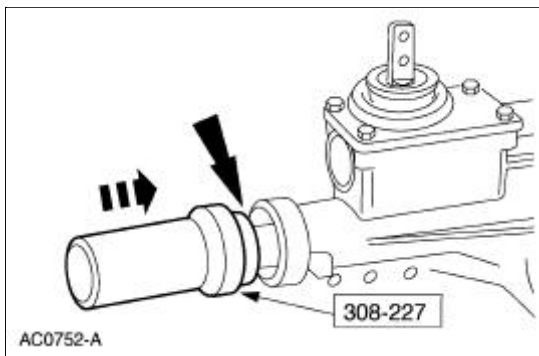

41. Install the case plug.

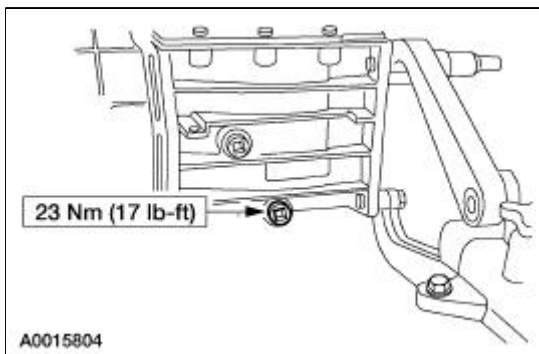

42. **NOTE:** Before installing the transmission, the ball stud, clutch release lever and the input shaft must be cleaned and lubricated with grease.

Install the clutch release hub and bearing and the clutch release lever. For additional information, refer to [Section 308-01](#).

---

## Input Shaft and Bearing

### Special Tool(s)

 <p>ST1895-A</p>	Remover, Driver Pinion Bearing Cone 205-D002 (D79L-4621-A) or equivalent
 <p>ST2388-A</p>	Installer, Drive Pinion Bearing Cone 205-011 (T57L-4621-B)
 <p>ST1303-A</p>	Remover/Installer, Bearing Tube 308-024 (T75L-7025-B)

### Disassembly and Assembly

1. Disassemble the input shaft.
  1. Remove the third/fourth synchronizer blocking ring.
  2. Remove the input shaft thrust washer.
  3. Remove the input shaft thrust bearing.
  4. Remove the input shaft pocket bearing.
    - Inspect all components for wear or damage. Install new components as necessary.

47. Install a new OSS sensor tone wheel retaining ring.

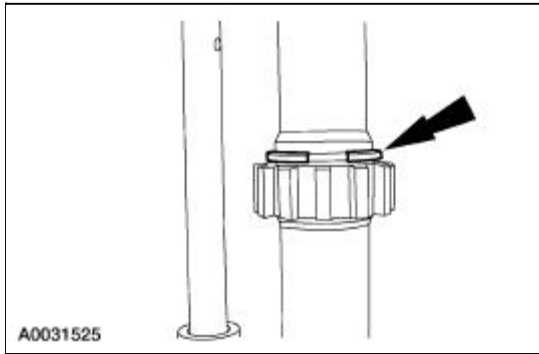

48. Install the fifth/reverse gear lockout.

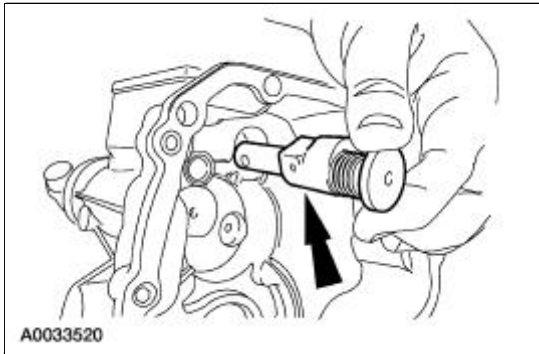

49. Install the bolt.

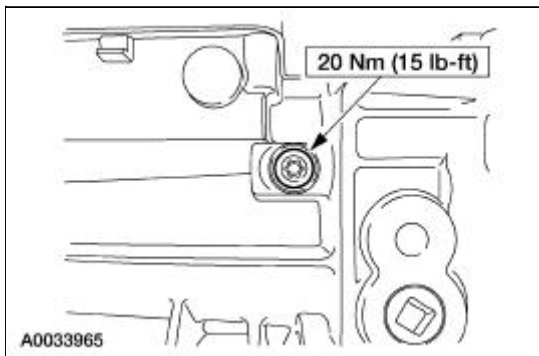

50. Clean the mating surfaces of the transmission main case and the extension housing. Apply a bead of silicone rubber to the sealing surface of the transmission case.

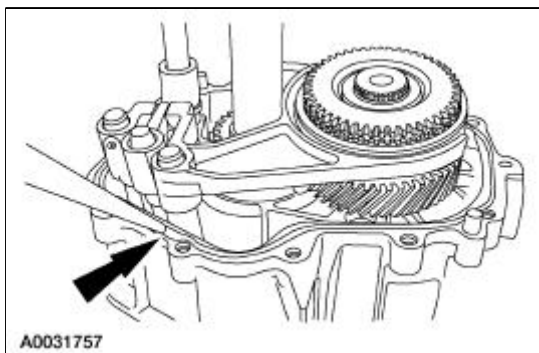

51. Install the extension housing and at the same time install the gear shift off-set lever.

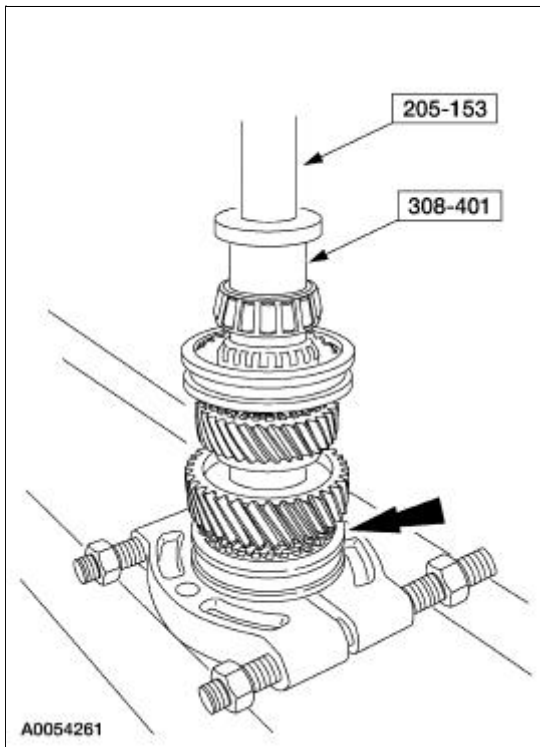

10. Install the first gear synchronizer thrust washer, the inner cone, the friction cone and the first gear synchronizer blocking ring.

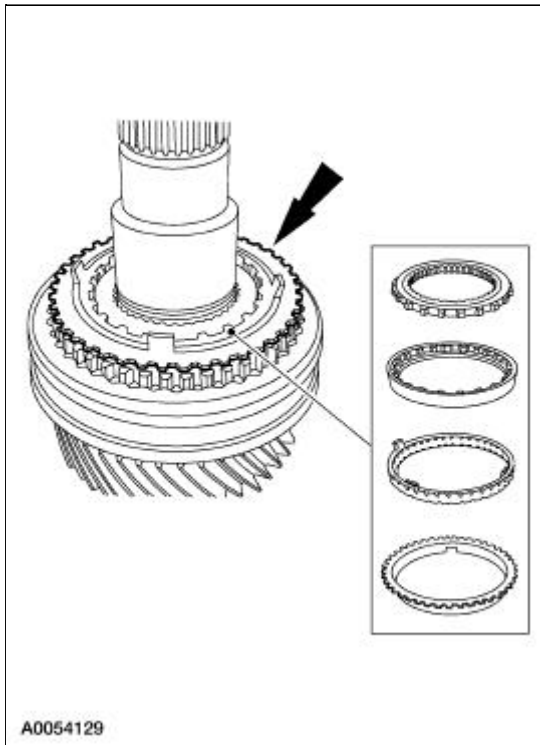

11. Install a new snap ring.



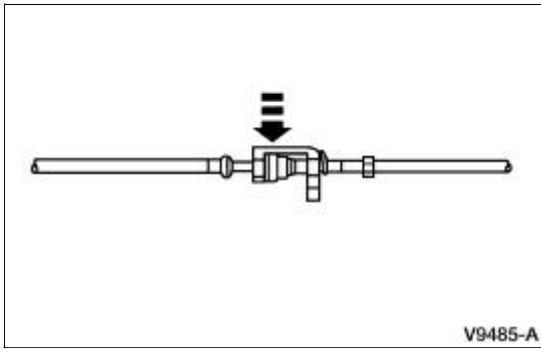



## Speed Control

Refer to Wiring Diagrams Cell [31](#), Speed Control for schematic and connector information.

### Special Tool(s)

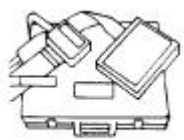
 ST2332-A	Worldwide Diagnostic System (WDS) 418-F224,  New Generation STAR (NGS) Tester 418-F052, or equivalent diagnostic tool
 ST1137-A	73 Digital Multimeter or equivalent 105-R0051
 ST1391-A	Breakout Box, EEC-V Control System 418-049, or equivalent 014-00950

### Principles of Operation

The speed control system is designed to maintain vehicle speed above 48 km/h (30 mph). After the ON switch is depressed, depressing the SET/ACCEL switch will activate the speed control servo. To increase a set speed, either depress and hold for continuous acceleration, or momentarily tap the SET/ACCEL switch for 1.6 km/h (1 mph) acceleration increments. To decrease a set speed, depress and hold the COAST switch until the target speed is reached, or momentarily tap the COAST switch for 1.6 km/h (1 mph) deceleration increments. When the speed control system has been disabled by tapping the brake pedal, the RESUME switch can be depressed and the vehicle will return to the original set speed if the vehicle is traveling over 48 km/h (30 mph) and the OFF switch has not been depressed.

**NOTE:** The deactivator switch is provided as an additional safety feature. Normally, when the brake pedal is depressed, an electrical signal from the brake lamp circuit to the speed control servo will deactivate the system. Under increased brake pedal effort, the deactivator switch will open and remove power to the speed control servo, releasing the throttle independent of the speed control servo.

**NOTE:** The air bag sliding contact provides the electrical interface between the steering column wiring and the speed control actuator switches in the steering wheel.

The inputs to the speed control servo are the:

- vehicle speed signal.

- Inspect to determine if one of the following mechanical or electrical concerns apply:

#### Visual Inspection Chart

Mechanical	Electrical
<ul style="list-style-type: none"> <li>Loose, missing or damaged A/C compressor drive belt.</li> <li>Loose or disconnected A/C clutch.</li> <li>Loose, misrouted or damaged vacuum lines. <sup>a</sup></li> <li>Broken or leaking refrigerant lines.</li> <li>Broken or leaking vacuum control motor.</li> </ul>	<ul style="list-style-type: none"> <li>Open fuses.</li> <li>Blower motor inoperative.</li> <li>A/C compressor inoperative.</li> <li>Circuitry open/shorted.</li> <li>Disconnected electrical connectors.</li> </ul>

<sup>a</sup> A leak in the vacuum control circuit may occur during acceleration (slow leak), at all times (large leak), or only when specific functions are selected (indicating a leak in that portion of the circuit). The vacuum hoses used in the passenger compartment control circuit are constructed from PVC plastic material. The vacuum hoses used in the engine compartment are constructed of Hytrel®. Because of the materials used, never pinch the vacuum hoses off during diagnosis to locate a leak. A wood golf tee can be used as a plug when it is necessary to plug one end of a vacuum hose for leak test purposes.

- If the inspection reveals obvious concerns that can be readily identified, repair as required.
- If the concern remains after the inspection, connect the scan tool to the data link connector (DLC) located beneath the instrument panel and select the vehicle to be tested from the scan tool menu. If the vehicle selection cannot be entered:
  - check that the program card is correctly installed.
  - check the connections to the vehicle.
  - check the ignition switch position.

If the scan tool still does not allow the vehicle selection to be entered, refer to the scan tool manual.

- Carry out the DATA LINK DIAGNOSTIC TEST using the scan tool. If the scan tool responds with:
  - CKT 914, CKT 915 or CKT 70 = ALL MODULE NO RESPONSE/NOT EQUIPPED, go to Communication System Diagnostics in [Section 418-00](#) to diagnose network concern.
  - If the powertrain control module (PCM) is not listed for a communication concern, turn the A/C function selector switch to OFF and execute self-test diagnostics for the PCM.
- If any PCM DTCs are retrieved, and are related to the concern, go to the Powertrain Control Module Diagnostic Trouble Code (DTC) Index to continue diagnostics.
- If no DTCs related to the concern are retrieved, go to the Symptom Chart to continue diagnostics.

#### Powertrain Control Module Diagnostic Trouble Code (DTC) Index

DTC	Description	Action
P1460	WOT A/C cutout circuit malfunction	Refer to the Powertrain Control/Emissions Diagnosis (PC/ED) manual.
P1464	A/C demand out of self-test range	GO to DTC P1464.

#### Symptom Chart

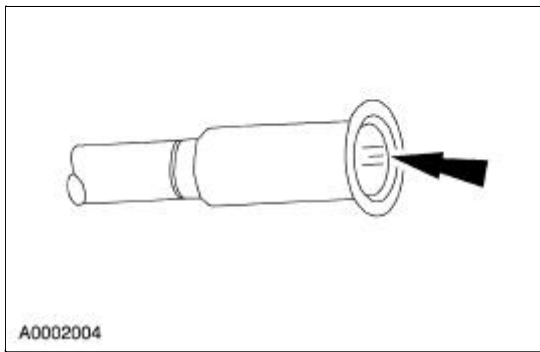

3.  **CAUTION:** Use only the new O-ring seals. The use of any O-ring seals other than those specified in the Ford Master Parts Catalog may result in intermittent leakage during vehicle operation.

Install the O-ring seals.

- Lubricate the O-ring seals with PAG Refrigerant Compressor Oil (R-134a Systems) or equivalent.

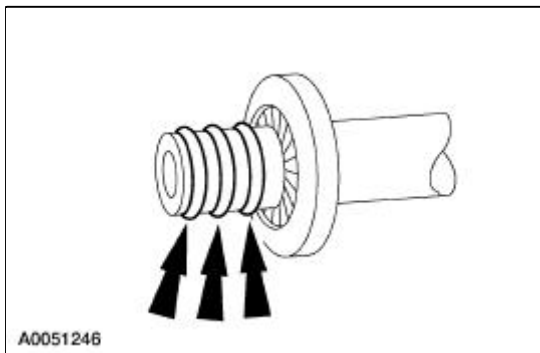

4. Connect the spring lock coupling fittings with a twisting motion until the A/C tube lock coupling spring snaps over the flared end of the female fitting.

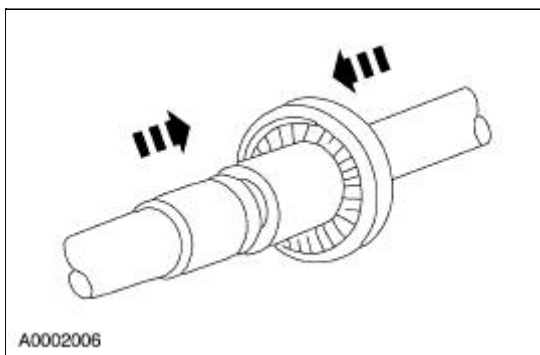

5. Install the A/C tube lock coupling clip.

## Register —LH

### Removal

1. Remove the instrument panel steering column cover bolts.

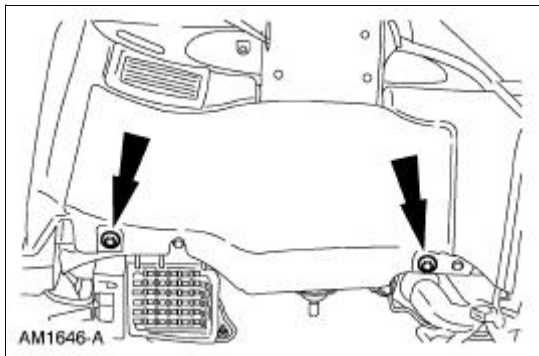

2. Unsnap and remove the instrument panel steering column cover.

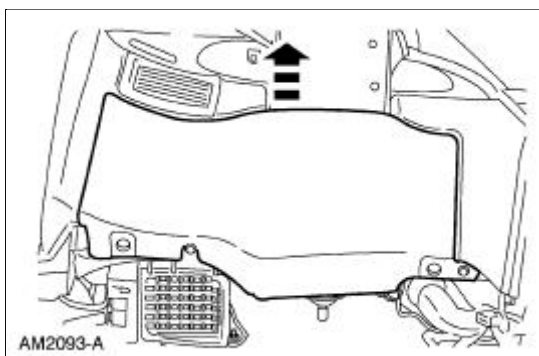

3. Remove the bolts and the steering column reinforcement.

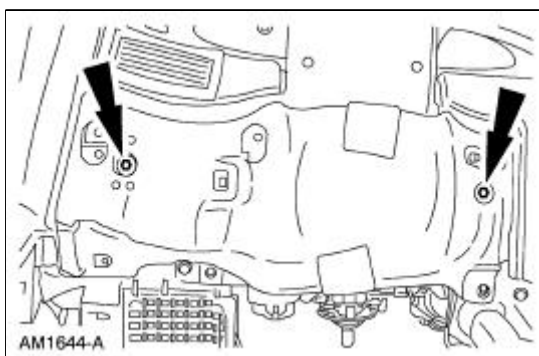

4. Remove the screws.

		19D734)
6	19D702	A/C charging valve cap

The fitting is an integral part of the refrigeration line or component.

- Special couplings are required for both the high side and low side service gauge ports.
  - A new Schrader-type valve core can be installed if the seal leaks.
  - Always install the A/C charging valve cap (19D702) on the service gauge port valves after repairing the refrigerant system.
-

6. To install, reverse the removal procedure.
    - Install new O-ring seals lubricated in clean PAG oil.
    - Lubricate the refrigerant system with the correct amount of clean PAG oil. For additional information, refer to [Section 412-00](#).
  7. Evacuate, leak test and charge the refrigerant system. For additional information, refer to [Section 412-00](#).
-

	<ul style="list-style-type: none"> <li>● 93-102 = 6.9-9.1 volts (low voltage)</li> <li>● 115-124 = 8.5-10.7 volts (norm band start)</li> <li>● 215-225 = 15.8-18 volts (norm band end)</li> <li>● 230-241 = 16.9-19.1 volts (high voltage)</li> </ul>
rhEo	Displays the present decimal rheostat dimming input, 0-255 (used when requesting assistance from the hotline).
rhi rhS rho	Not used.
Cr	Displays the present RUN/START sense input. Display will show -h for high input with the ignition switch in the START position and -L for low input with the ignition switch in the RUN position.
PA-PE7	Not used.
GAGE	Repeats test display cycle.

To exit the instrument cluster self-diagnostic mode, turn the ignition switch to the OFF position or press and hold the SELECT/RESET button for three or more seconds and release.

#### Instrument Cluster Diagnostic Trouble Code (DTC) Index

Diagnostic Tool Displayed DTC	Self-Diagnostic Mode Displayed DTC	Description	Source	Action
B1202	9202	Fuel Sender Open Circuit	Instrument Cluster	<a href="#">Go To Pinpoint Test B.</a>
B1204	9204	Fuel Sender Short to Ground	Instrument Cluster	<a href="#">Go To Pinpoint Test B.</a>
B1317	9317	Battery Voltage High	Instrument Cluster	<a href="#">Section 414-00.</a>
B1318	9318	Battery Voltage Low	Instrument Cluster	<a href="#">Section 414-00.</a>
B1342	9342	ECU is Defective	Instrument Cluster	INSTALL a new instrument cluster; REFER to <a href="#">Instrument Cluster</a> in this section. TEST the system for normal operation.
B1343	9343	Heated Backlight Input Circuit Failure	Instrument Cluster	<a href="#">Section 501-11.</a>
B1356	9356	Ignition Run Circuit Open	Instrument Cluster	<a href="#">Go To Pinpoint Test A.</a>
B1364	9364	Ignition Start Circuit Open	Instrument Cluster	<a href="#">Go To Pinpoint Test A.</a>
B2143	A143	Odometer NVM Memory Failure	Instrument Cluster	<a href="#">Go To Pinpoint Test J.</a>
C1284	5284	Oil Pressure Switch Failure	Instrument Cluster	<a href="#">Go To Pinpoint Test C.</a>
P1197	1197	Mileage Switch Circuit Failure	Instrument Cluster	<a href="#">Go To Pinpoint Test J.</a>

	module. ● Horn switch.	
--	---------------------------	--

**Pinpoint Tests**

**PINPOINT TEST A: THE HORN DOES NOT SOUND**

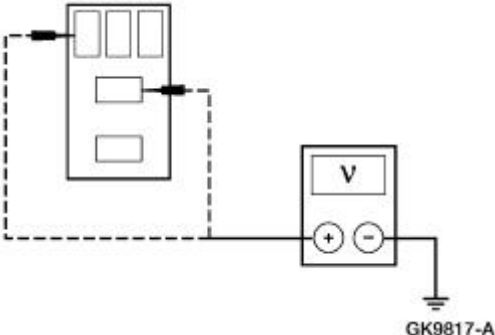
Test Step	Result / Action to Take						
<p><b>A1 CHECK POWER SUPPLY TO HORN RELAY</b></p> <ul style="list-style-type: none"> <li>● Disconnect: Horn Relay.</li> <li>● Measure the voltage between the horn relay connector Pin 2, Circuit 460 (YE/LB), harness side and ground; and between the horn relay connector Pin 5, Circuit 460 (YE/LB), harness side and ground.</li> </ul>  <p style="text-align: center;">GK9817-A</p> <ul style="list-style-type: none"> <li>● Are the voltages greater than 10 volts?</li> </ul>	<p><b>Yes</b> GO to <a href="#">A2</a>.</p> <p><b>No</b> REPAIR the circuit in question. TEST the system for normal operation.</p>						
<p><b>A2 CHECK HORN RELAY</b></p> <ul style="list-style-type: none"> <li>● Check the horn relay; refer to Wiring Diagrams Cell 149.</li> <li>● Is the horn relay OK?</li> </ul>	<p><b>Yes</b> GO to <a href="#">A3</a>.</p> <p><b>No</b> INSTALL a new horn relay. TEST the system for normal operation.</p>						
<p><b>A3 CHECK HORN SWITCH SIGNAL TO HORN RELAY</b></p> <ul style="list-style-type: none"> <li>● Measure the resistance between horn relay connector Pin 1, Circuit 6 (YE/LG), harness side and ground under the following conditions:</li> </ul> <p><b>Horn Switch Position</b></p> <table border="1" style="width: 100%; border-collapse: collapse;"> <thead> <tr> <th style="text-align: center;">Horn Switch Position</th> <th style="text-align: center;">Resistance</th> </tr> </thead> <tbody> <tr> <td style="text-align: center;">Pressed</td> <td style="text-align: center;">Less than 5 ohms</td> </tr> <tr> <td style="text-align: center;">Released</td> <td style="text-align: center;">Greater than 10,000 ohms</td> </tr> </tbody> </table>	Horn Switch Position	Resistance	Pressed	Less than 5 ohms	Released	Greater than 10,000 ohms	<p><b>Yes</b> GO to <a href="#">A4</a>.</p> <p><b>No</b> GO to <a href="#">A5</a>.</p>
Horn Switch Position	Resistance						
Pressed	Less than 5 ohms						
Released	Greater than 10,000 ohms						

## INCREASES VOLTAGE

Test Step	Result / Action to Take
<b>D1 CHECK I CIRCUIT 904 (LG/RD) FOR A SHORT TO GROUND</b>	
<ul style="list-style-type: none"> <li>● Disconnect: Generator C102c (4.6L 4V) or C102a (3.8L or 4.6L 2V).</li> <li>● Key in ON position.</li> <li>● With the ignition switch in the RUN position, check the charging system warning indicator.</li> <li>● <b>Is the charging system warning indicator illuminated?</b></li> </ul>	<p><b>Yes</b> REPAIR circuit 904 (LG/RD) for a short to ground. TEST the system for normal operation.</p> <p><b>No</b> INSTALL a new generator. REFER to <a href="#">Section 414-02</a>. TEST the system for normal operation.</p>

## PINPOINT TEST E: THE CHARGING SYSTEM WARNING INDICATOR IS OFF WITH THE IGNITION SWITCH IN THE RUN POSITION AND THE ENGINE OFF

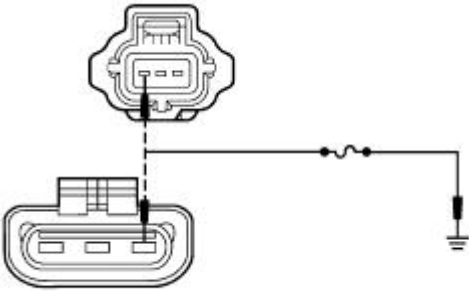
Test Step	Result / Action to Take
<b>E1 CHECK THE CHARGING SYSTEM WARNING INDICATOR LAMP</b>	
<ul style="list-style-type: none"> <li>● Disconnect: Generator C102c (4.6L 4V) or C102a (3.8L or 4.6L 2V).</li> <li>● With the engine off, connect a fused (15A) jumper wire between the generator C102c (4.6L 4V) or C102a (3.8L or 4.6L 2V) pin 1, circuit 904 (LG/RD), harness side and ground.</li> </ul>  <p>A0030366</p> <ul style="list-style-type: none"> <li>● Key in ON position.</li> <li>● <b>Is the charging system warning indicator lamp illuminated?</b></li> </ul>	<p><b>Yes</b> INSTALL a new generator. REFER to <a href="#">Section 414-02</a>. TEST the system for normal operation.</p> <p><b>No</b> REFER to <a href="#">Section 413-01</a> for diagnosis and testing of the instrument cluster.</p>

## PINPOINT TEST F: THE CHARGING SYSTEM WARNING INDICATOR LAMP FLICKERS OR IS INTERMITTENT

Test Step	Result / Action to Take
<b>F1 CHECK FOR LOOSE CONNECTIONS</b>	
<ul style="list-style-type: none"> <li>● Check all generator, battery, and power distribution connections for looseness, corrosion, loose or bent terminals, or loose eyelets.</li> <li>● <b>Are all connections clean and tight?</b></li> </ul>	<p><b>Yes</b> GO to <a href="#">F2</a>.</p> <p><b>No</b></p>

For Mach 1000 subwoofer speakers, GO to [D8](#).

**D2 CHECK CIRCUITS BETWEEN THE AFFECTED SPEAKER(S) AND SUBWOOFER AMPLIFIERS**

- Disconnect: Subwoofer Amplifier C4108a.
- Disconnect: Subwoofer Amplifier C4109b.
- Disconnect: Affected Speaker(s).
- Measure the resistance between the subwoofer amplifier and the affected speaker(s) and between the subwoofer amplifier and ground as follows:

**Speaker Circuits**

Affected Speaker Pin	Subwoofer Amplifier Pin	Circuit
RF 1 (convertible only)	LH 7	822 (BK/LG)
RF 2 (convertible only)	LH 8	287 (BK/WH)
LF 1 (convertible only)	LH 7	822 (BK/LG)
LF 2 (convertible only)	LH 8	287 (BK/WH)
RR 1	RH 7	822 (BK/LG)
RR 2	RH 8	287 (BK/WH)
LR 1	RH 7	822 (BK/LG)
LR 2	RH 8	287 (BK/WH)

- Are the resistances less than 5 ohms between the subwoofer amplifier and the affected speaker(s) and greater than 10,000 ohms between the subwoofer amplifier and ground?

**Yes**  
GO to [D3](#).

**No**  
REPAIR the circuit (s) in question.  
TEST the system for normal operation.

**D3 CHECK CIRCUITS BETWEEN THE AUDIO UNIT AND THE SUBWOOFER AMPLIFIERS**

- Disconnect: Audio Unit C290b.
- Disconnect: Subwoofer Amplifier C4108a.
- Disconnect: Subwoofer Amplifier C4109b.
- Measure the resistance between the subwoofer amplifier and the audio unit C290b and between the subwoofer amplifier and ground as follows:

**Speaker Circuits**

Audio Unit C290b Pin	Subwoofer Amplifier Pin	Circuit
2	LH 5	167 (BN/OG)
6	RH 5	169 (LG/BK)
1	LH 6	168 (RD/BK)
5	RH 6	172 (LB/RD)

- Are the resistances less than 5 ohms between the subwoofer amplifier and the audio unit and greater than 10,000 ohms between the subwoofer amplifier and ground?

**Yes**  
GO to [D6](#).

**No**  
REPAIR the circuit (s) in question.  
TEST the system for normal operation.

**D4 CHECK CIRCUITS BETWEEN THE AFFECTED SPEAKER(S) AND SUBWOOFER AMPLIFIER**

- Disconnect: Subwoofer Amplifier C4109b.
- Disconnect: Affected Speaker(s).
- Measure the resistance between the subwoofer amplifier and the

**Yes**  
GO to [D5](#).





tool — instrument cluster	<ul style="list-style-type: none"> <li>● Instrument cluster.</li> </ul>	<a href="#">Test D.</a>
<ul style="list-style-type: none"> <li>● The module does not respond to the diagnostic tool — powertrain control module (PCM)</li> </ul>	<ul style="list-style-type: none"> <li>● Wire or connection in SCP communication network.</li> <li>● PCM.</li> </ul>	<ul style="list-style-type: none"> <li>● GO to <a href="#">Pinpoint Test E.</a></li> </ul>
<ul style="list-style-type: none"> <li>● No module/network communication — ISO 9141 network</li> </ul>	<ul style="list-style-type: none"> <li>● Wire or connection in ISO 9141 communication network.</li> <li>● ISO 9141 networked modules.</li> </ul>	<ul style="list-style-type: none"> <li>● GO to <a href="#">Pinpoint Test F.</a></li> </ul>
<ul style="list-style-type: none"> <li>● No module/network communication — SCP network</li> </ul>	<ul style="list-style-type: none"> <li>● Wire or connection in SCP communication network.</li> <li>● SCP networked modules.</li> </ul>	<ul style="list-style-type: none"> <li>● GO to <a href="#">Pinpoint Test G.</a></li> </ul>
<ul style="list-style-type: none"> <li>● No module/network communication — no power to the diagnostic tool</li> </ul>	<ul style="list-style-type: none"> <li>● CJB Fuse 31 (5A).</li> <li>● DLC pins.</li> <li>● Scan tool.</li> <li>● Circuitry.</li> </ul>	<ul style="list-style-type: none"> <li>● GO to <a href="#">Pinpoint Test H.</a></li> </ul>

### Pinpoint Tests



**CAUTION:** Be careful when probing the CJB, battery junction box (BJB) or any connectors. Damage will result to the connector receptacle if the probe or terminal being used is too large.



**CAUTION:** Electronic modules are sensitive to static electrical charges. If exposed to these charges, damage may result.

**NOTE:** If DTCs are recorded and the symptom is not present when carrying out the pinpoint tests, an intermittent concern may be the cause. Always check for loose connections and corroded pins.

## PINPOINT TEST A: THE MODULE DOES NOT RESPOND TO THE DIAGNOSTIC TOOL — ANTI-LOCK BRAKE CONTROL MODULE

Test Step	Result / Action to Take
<b>A1 CHECK THE VEHICLE FOR TRACTION CONTROL</b>	
<ul style="list-style-type: none"> <li>● Check the vehicle for a traction control disable switch.</li> <li>● <b>Is a traction control disable switch present?</b></li> </ul>	<p><b>Yes</b> GO to <a href="#">A2.</a></p> <p><b>No</b> GO to <a href="#">A9.</a></p>
<b>A2 CHECK ANTI-LOCK BRAKE CONTROL MODULE C141 FOR DAMAGE</b>	
<ul style="list-style-type: none"> <li>● Key in OFF position.</li> <li>● Disconnect: Anti-Lock Brake Control Module C135.</li> <li>● Inspect the anti-lock brake control module C135 for damage; repair as necessary.</li> <li>● Connect: Anti-Lock Brake Control Module C135.</li> <li>● Connect the diagnostic tool.</li> <li>● Key in ON position.</li> <li>● Enter the following diagnostic mode on the diagnostic tool: Diagnostic Data Link.</li> </ul>	<p><b>Yes</b> GO to <a href="#">A3.</a></p> <p><b>No</b> GO to <a href="#">A6.</a></p>

## CORRECTLY — NVM CONFIGURATION FAILURE (NO PCM ID EXCHANGED BETWEEN INSTRUMENT CLUSTER AND PCM)

Test Step	Result / Action to Take
<p><b>K1 USE THE DTCS FROM THE INSTRUMENT CLUSTER SELF TESTS</b></p> <ul style="list-style-type: none"> <li>● Use the recorded results from the Instrument Cluster Continuous and On-Demand Self-Tests.</li> <li>● <b>Are any DTCs recorded?</b></li> </ul>	<p><b>Yes</b> If DTC B2141 only is retrieved, GO to <a href="#">K2</a>.</p> <p>If DTC U1147 is retrieved with DTC B2141, GO to <a href="#">Pinpoint Test C</a>.</p> <p><b>No</b> System is OK.</p>
<p><b>K2 CARRY OUT KEEP ALIVE MEMORY RESET FROM PCM</b></p> <ul style="list-style-type: none"> <li>● Use diagnostic card for PCM Active Command — Keep Alive Memory Reset.</li> <li>● Key in OFF position.</li> <li>● Key in ON position.</li> <li>● Leave the key in the run position for thirty seconds.</li> <li>● Key in OFF position.</li> <li>● Start the vehicle.</li> <li>● <b>Does the vehicle start?</b></li> </ul>	<p><b>Yes</b> System is OK.</p> <p><b>No</b> GO to <a href="#">K3</a>.</p>
<p><b>K3 RETRIEVE THE INSTRUMENT CLUSTER DTCS</b></p> <ul style="list-style-type: none"> <li>● Enter the following diagnostic mode on the diagnostic tool: Clear Continuous DTCs.</li> <li>● Key in OFF position.</li> <li>● Key in ON position.</li> <li>● Key in OFF position.</li> <li>● Enter the following diagnostic mode on the diagnostic tool: Instrument Cluster On-Demand Self-Test.</li> <li>● <b>Is DTC B2141 retrieved?</b></li> </ul>	<p><b>Yes</b> REPEAT K2. If the fault persists, verify the PCM calibration. If the calibration is OK, INSTALL a new instrument cluster. for additional information, REFER to <a href="#">Section 413-01</a>. Cycle the ignition key to run using two encoded ignition keys. GO to <a href="#">Pinpoint Test J</a> to initialize the module. REPEAT the self-test. CLEAR the DTCs.</p> <p><b>No</b> REFER to the DTC index.</p>

---



Circuit	position	resistance
Passenger		
543 (DG)	Left	Greater than 10 volts
543 (DG)	Right	Less than 5 ohms
544 (VT)	Up	Greater than 10 volts
544 (VT)	Down	Less than 5 ohms
542 (YE)	Left	Less than 5 ohms
542 (YE)	Right	Greater than 10 volts
542 (YE)	Up	Less than 5 ohms
542 (YE)	Down	Greater than 10 volts

- Is the circuit logic OK?

#### C2 CHECK THE EXTERIOR REAR VIEW MIRROR CONTROL

- Remove the exterior rear view mirror control. Leave the harness connected.
- Measure for voltage or resistance at exterior rear view mirror control C527 while actuating the exterior rear view mirror control according to the following chart.

Pin	Circuit	Exterior rear view mirror control position	Measure for resistance or voltage
6	542 (YE)	Left	Less than 5 ohms
6	542 (YE)	Right	Greater than 10 volts
6	542 (YE)	Up	Less than 5 ohms
6	542 (YE)	Down	Greater than 10 volts
Driver side selected			
4	540 (RD)	Left	Greater than 10 volts
4	540 (RD)	Right	Less than 5 ohms
3	541 (DB)	Up	Greater than 10 volts
3	541 (DB)	Down	Less than 5 ohms
Passenger side selected			
8	543	Left	Greater than 10

**Yes**  
REPAIR the circuits. TEST the system for normal operation.

**No**  
INSTALL a new exterior rear view mirror control. REFER to [Switch—Exterior Rear View Mirror Control](#) in this section. TEST the system for normal operation.

## Latch —Front Seat Backrest

### Removal

**NOTE:** The power seat backrest adjuster assembly must be installed as a new unit. Repair of the power seat backrest adjuster assembly components is not acceptable and should not be attempted.

1. Remove the two screws and the seat backrest latch cover.

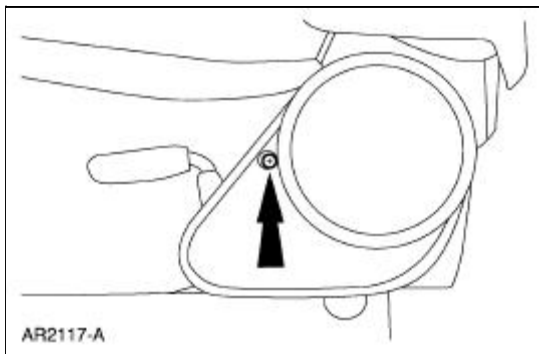

2. Remove the seat backrest latch handle knob (62762).

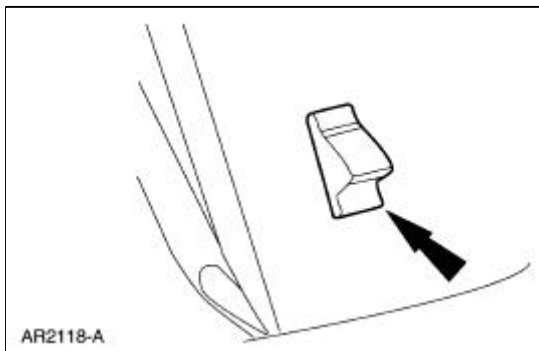

3. Release the J-retainer.

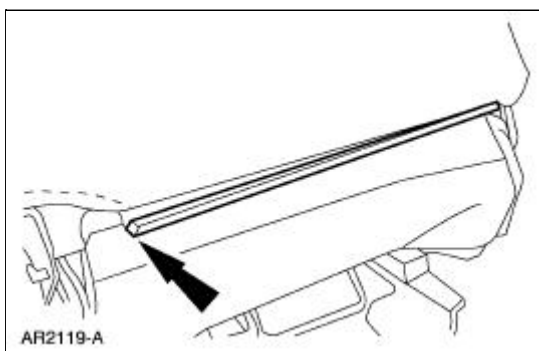

4. Remove the screw.

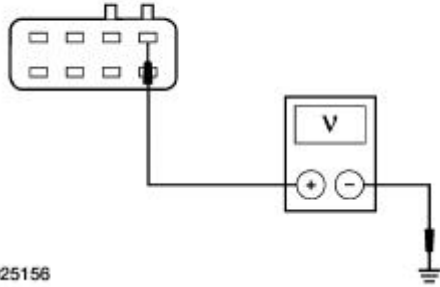

A0025156

- Is the voltage greater than 10 volts?

#### H14 CHECK INPUT TO THE ICM

- Connect: Rear Window Defrost Switch C241.
- Depress the rear window defrost switch to ON.
- Measure the voltage between ICM C220a pin 9, circuit 175 (BK/YE), harness side and ground.

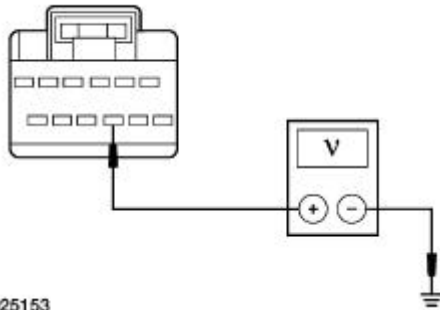

A0025153

- Is the voltage greater than 10 volts?

**Yes**  
GO to [H16](#).

**No**  
GO to [H15](#).

#### H15 CHECK CIRCUIT 175 (BK/YE) FOR AN OPEN

- Key in OFF position.
- Measure the resistance between ICM C220a pin 9, circuit 175 (BK/YE), harness side and the rear window defrost switch C241 pin 2, circuit 175 (BK/YE), harness side.

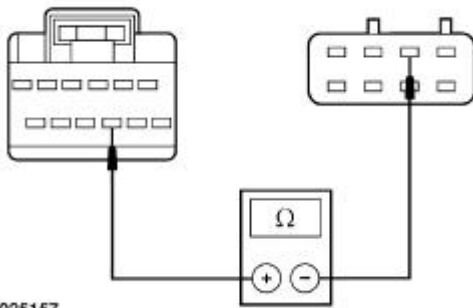

A0025157

- Is the resistance less than 5 ohms?

**Yes**  
INSTALL a new rear window defrost switch. REFER to [Rear Window Defrost Switch](#) in this section. TEST the system for normal operation.

**No**  
REPAIR the circuit. TEST the system for normal operation.

#### H16 CHECK THE ICM FOR CORRECT OPERATION

- Disconnect all ICM connectors.
- Check for:
  - corrosion
  - pushed-out pins
- Connect all ICM connectors and make sure they seat correctly.
- Operate the system and verify the concern is still present.
- Is the concern still present?

**Yes**  
INSTALL a new ICM. REFER to [Section 413-01](#). CLEAR the DTCs. REPEAT the self-test.

**No**  
The system is operating correctly at this time. Concern may have been

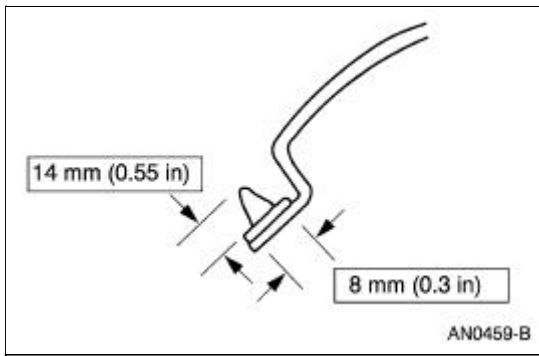

10.  **CAUTION:** Open a window to prevent the windshield glass from being pushed out by air pressure when a door is closed.

Using the alignment marks install the windshield glass.

11. After the glass is set, check for water leaks and add urethane adhesive where needed.
12. Install the cowl grille.

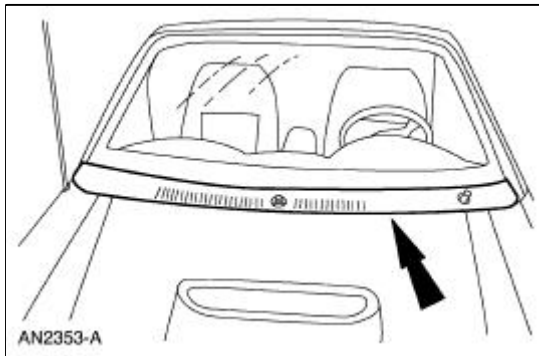

13. Install the cowl grille weatherstrip.

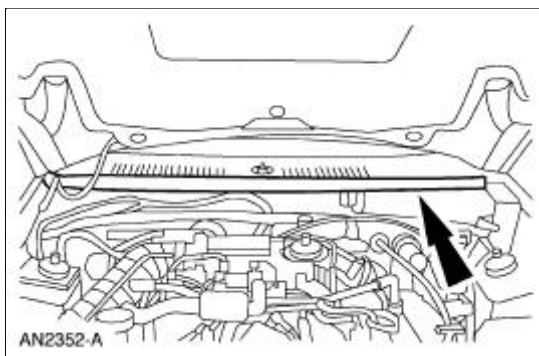

14. Install the two windshield wiper pivot arms.
- Position the arms.
  - Install the windshield wiper pivot arms.
15. Install the headliner.

## Coupe

16. Install the sun visors and clips.

## Ignition Lock Cylinder —Non-Functional

### Removal and Installation

1. **NOTE:** Make sure the front wheels are in the straight-ahead position.

Disconnect the battery ground cable (14301) and wait at least one minute to allow the depletion of the restraint system backup power supply. For additional information, refer to [Section 414-01](#).

2.  **WARNING:** To avoid the risk of serious personal injury, read and follow all warnings, cautions, notes and instructions in the deactivation procedure.

Deactivate the supplemental restraint system (SRS). For additional information, refer to Supplemental Restraint System (SRS) Deactivation and Reactivation in this section.

3.  **WARNING:** To reduce the risk of serious personal injury, read and follow all warnings, cautions, notes and instructions in the steering wheel removal and installation procedure.

Remove the steering wheel assembly. For additional information, refer to Wheel in this section.

4. Twist off the cap from the ignition switch cylinder.



5. **NOTE:** The lock cylinder is repaired by discarding the inoperative lock cylinder and building a new lock cylinder using the appropriate lock repair package (F85Z-11582-AA). The lock repair package includes a detailed instruction sheet to build the new lock cylinder to the current key code of the vehicle.

	Short to Battery		
B1434	Wiper HIGH and LOW Speed Relay Coil Circuit Failure	GEM	GO to <a href="#">Pinpoint Test B</a> .
B1436	Wiper HIGH and LOW Speed Relay Coil Circuit Short to Battery	GEM	GO to <a href="#">Pinpoint Test B</a> .
B1438	Wiper Mode Select Switch Circuit Failure	GEM	GO to <a href="#">Pinpoint Test B</a> .
B1441	Wiper Mode Select Switch Circuit Short to Ground	GEM	GO to <a href="#">Pinpoint Test B</a> .
B1446	Wiper Park Sense Circuit Failure	GEM	GO to <a href="#">Pinpoint Test B</a> .
B1448	Wiper Park Sense Circuit Short to Battery	GEM	GO to <a href="#">Pinpoint Test B</a> .
B1450	Wiper Wash/Delay Switch Circuit Failure	GEM	GO to <a href="#">Pinpoint Test C</a> .
B1453	Wiper Wash/Delay Switch Circuit Short to Ground	GEM	GO to <a href="#">Pinpoint Test C</a> .
B1458	Wiper Washer Pump Motor Relay Circuit Failure	GEM	GO to <a href="#">Pinpoint Test C</a> .
B1460	Wiper Washer Pump Motor Relay Coil Circuit Short to Battery	GEM	GO to <a href="#">Pinpoint Test C</a> .
B1462	Safety Belt Switch Circuit Failure	GEM	REFER to <a href="#">Section 413-09</a> .
B1466	Wiper HIGH and LOW Speed Not Switching	GEM	GO to <a href="#">Pinpoint Test B</a> .
B1473	Wiper Low Speed Circuit Motor Failure	GEM	GO to <a href="#">Pinpoint Test B</a> .
B1476	Wiper High Speed Circuit Motor Failure	GEM	GO to <a href="#">Pinpoint Test B</a> .
B1551	Decklid Release Circuit Failure	GEM	REFER to <a href="#">Section 501-14B</a> .
B1553	Decklid Release Circuit Short to Battery	GEM	REFER to <a href="#">Section 501-14B</a> .
B1555	Ignition Run/Start Circuit Failure	GEM	REFER to <a href="#">Section 211-05</a> .
B1687	Lamp Dome Input Circuit Short to Battery	GEM	REFER to <a href="#">Section 417-02</a> .
B2486	LF Side Repeater Lamp Output Circuit Failure	GEM	REFER to <a href="#">Section 417-01</a> .
B2488	RF Side Repeater Lamp Output Circuit Failure	GEM	REFER to <a href="#">Section 417-01</a> .
C1189	Brake Fluid Level Sensor Input Short Circuit to Ground	GEM	REFER to <a href="#">Section 413-01</a> .
C1223	Lamp Brake Warning Output Circuit Failure	GEM	REFER to <a href="#">Section 413-01</a> .
C1225	Lamp Brake Warning Output Circuit Short to Battery	GEM	REFER to <a href="#">Section 413-01</a> .

<p>convertible top system to operate.</p> <ul style="list-style-type: none"> <li>● Key in ON position.</li> <li>● Actuate the convertible top switch to the LOWER and RAISE positions.</li> <li>● <b>Did the convertible top operate to the full down and full up position without hesitating?</b></li> </ul>	<p>ADJUST the convertible top linkage. TEST the system for normal operation.</p> <p><b>No</b> GO to <a href="#">B2</a>.</p>
<b>B2 CHECK THE MOTOR OPERATION</b>	
<ul style="list-style-type: none"> <li>● Gain access to the convertible top motor/pump assembly.</li> <li>● Operate the convertible top to the LOWER and RAISE positions while listening to the motor.</li> <li>● <b>Did the motor stop and then continue at any time?</b></li> </ul>	<p><b>Yes</b> <a href="#">Go To Pinpoint Test A.</a></p> <p><b>No</b> GO to <a href="#">B3</a>.</p>
<b>B3 CHECK THE CONVERTIBLE TOP LINKAGE</b>	
<ul style="list-style-type: none"> <li>● Operate the convertible top to the LOWER and RAISE positions while observing the convertible top linkage.</li> <li>● <b>Did the linkage operate smoothly without binding?</b></li> </ul>	<p><b>Yes</b> <a href="#">Go To Pinpoint Test D.</a></p> <p><b>No</b> ADJUST the convertible top linkage. TEST the system for normal operation.</p>

## PINPOINT TEST C: THE CONVERTIBLE TOP DOES NOT RAISE OR DOES NOT GO UP ALL THE WAY

Test Step	Result / Action to Take
<b>C1 CHECK THE CONVERTIBLE TOP OPERATION</b>	
<p><b>NOTE:</b> The parking brake must be applied for the convertible top system to operate.</p> <ul style="list-style-type: none"> <li>● Key in ON position.</li> <li>● Actuate the convertible top switch to the RAISE position.</li> <li>● <b>Did the motor operate?</b></li> </ul>	<p><b>Yes</b> GO to <a href="#">C2</a>.</p> <p><b>No</b> <a href="#">Go To Pinpoint Test A.</a></p>
<b>C2 CHECK THE CONVERTIBLE TOP LINKAGE</b>	
<ul style="list-style-type: none"> <li>● Operate the convertible top to the LOWER and RAISE positions while observing the convertible top linkage.</li> <li>● <b>Did the linkage bind and prevent the convertible top from raising?</b></li> </ul>	<p><b>Yes</b> ADJUST the convertible top linkage. TEST the system for normal operation.</p> <p><b>No</b> <a href="#">Go To Pinpoint Test D.</a></p>

## PINPOINT TEST D: THE CONVERTIBLE TOP HYDRAULIC SYSTEM

Test Step	Result / Action to Take
<b>D1 CHECK THE FLUID LEVEL</b>	
<p><b>NOTE:</b> The fluid level should be even with the bottom of the filler plug hole.</p> <p><b>NOTE:</b> Place an absorbent cloth below the filler plug when checking the fluid level.</p> <ul style="list-style-type: none"> <li>● Remove the filler plug and check the</li> </ul>	<p><b>Yes</b> GO to <a href="#">D3</a>.</p> <p><b>No</b> GO to <a href="#">D2</a>.</p>

## Stay Pad —Convertible Top

### Removal

1. Remove the convertible top material. For additional information, refer to [Convertible Top Material](#) in this section.
2. Remove the rear window glass. For additional information, refer to [Convertible Top Assembly—Rear Window Glass](#) in this section.
3. **NOTE:** Mark the old stay pad staple locations and transfer to the new stay pads.

Remove the staples from all of the bows.

### Installation

1. Staple the stay pad to the number one bow.

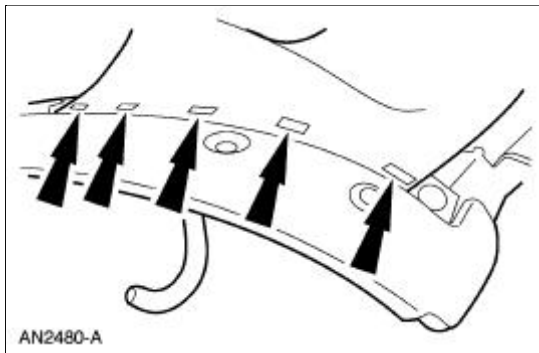

2. **NOTE:** The stay pad should be tight between the number one and number four bows.

Staple the stay pad to the number four bow.

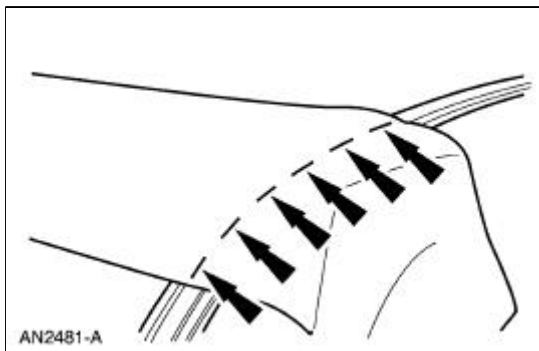

3. Cut the excess stay pad material from the rear of the number four bow.

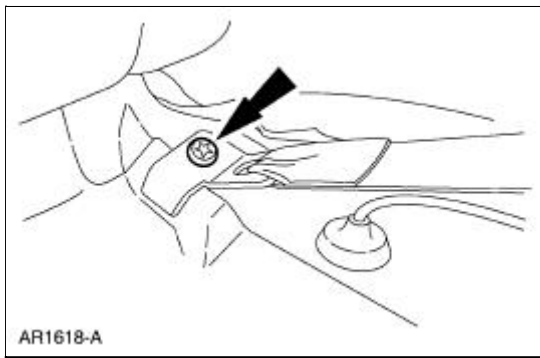

## Installation

**NOTE:** Make sure the safety belt is not twisted when inserting it in the quarter trim panel.

1. Install the bolt.

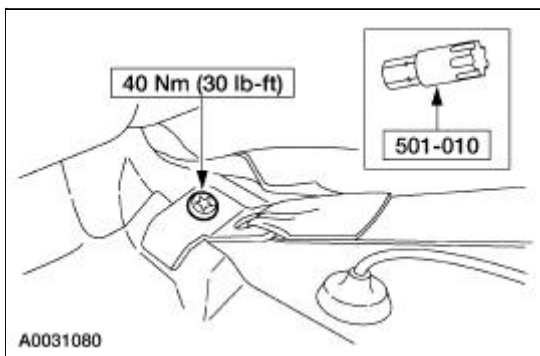
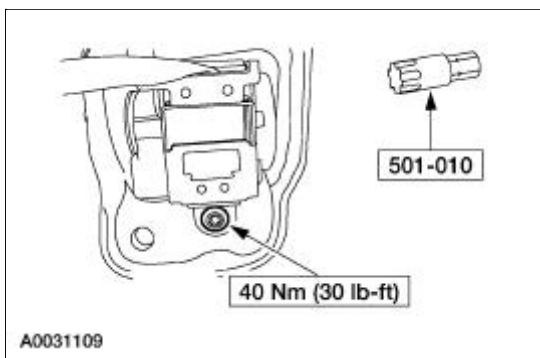

2. Using the special tool, install the safety belt retractor and the bolt.

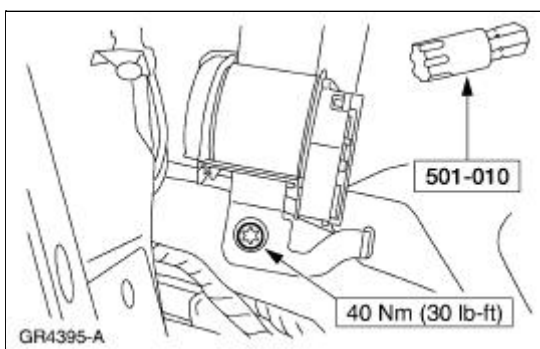

3. Using the special tool, install the D-ring bolt.

<b>F1 CHECK FOR A HARD OR INTERMITTENT DTC</b>	
<ul style="list-style-type: none"> <li>● Key in OFF position.</li> <li>● Connect the diagnostic tool. Scan Tool</li> <li>● Key in ON position.</li> <li>● Enter the following diagnostic mode on the diagnostic tool: Retrieve/Clear Continuous DTCs.</li> <li>● Retrieve and record any continuous DTCs for use later in this pinpoint test.</li> <li>● Enter the following diagnostic mode on the diagnostic tool: On-Demand Self Test.</li> <li>● <b>Was DTC B1888 retrieved during the on-demand self test?</b></li> </ul>	<p><b>Yes</b> This is a hard fault. The fault condition is still present. This fault cannot be cleared until it is corrected and the DTC is no longer retrieved during the on-demand self test. GO to <a href="#">F2</a>.</p> <p><b>No</b> This is an intermittent fault. The fault condition is not present at this time. GO to <a href="#">F5</a>.</p>
<b>F2 CHECK THE PASSENGER AIR BAG MODULE</b>	
<p> <b>WARNING:</b> If the supplemental restraint system (SRS) is being serviced, the system must be deactivated and restraint system diagnostic tools must be installed. Refer to <a href="#">Air Bag Supplemental Restraint System (SRS)</a> in this section.</p> <p><b>The air bag restraint system diagnostic tools must be removed and the air bag modules reconnected when the system is reactivated to avoid non-deployment in a collision, resulting in possible personal injury. NOTE:</b> Diagnostics or repairs are not to be performed on a seat equipped with a seat side air bag with the seat in the vehicle. Prior to attempting to diagnose or repair a seat concern when equipped with a seat side air bag, the seat must be removed from the vehicle and the restraint system diagnostic tools must be installed in the seat side air bag electrical connectors. <b>The restraint system diagnostic tools must be removed prior to operating the vehicle over the road. NOTE:</b> After diagnosing or repairing an SRS, the restraint system diagnostic tools must be removed before operating the vehicle over the road. NOTE: After diagnosing or repairing a seat system, the restraint system diagnostic tools must be removed before operating the vehicle over the road. NOTE: The SRS must be fully operational and free of faults before releasing the vehicle to the customer.</p> <ul style="list-style-type: none"> <li>● Key in OFF position.</li> <li>● Deactivate the system. Refer to <a href="#">Air Bag Supplemental Restraint System (SRS)</a> in the Diagnosis and Testing portion of this section.</li> <li>● Key in OFF position.</li> <li>● Key in ON position.</li> <li>● Enter the following diagnostic mode on the diagnostic tool: On-Demand Self Test.</li> <li>● <b>Was DTC B1888 retrieved?</b></li> </ul>	<p><b>Yes</b> GO to <a href="#">F3</a>.</p> <p><b>No</b> INSTALL a new passenger air bag module. GO to <a href="#">F6</a>.</p>
<b>F3 CHECK THE PASSENGER AIR BAG MODULE CIRCUIT</b>	
<ul style="list-style-type: none"> <li>● Key in OFF position.</li> <li>● Disconnect: RCM C2041.</li> <li>● <b>NOTE:</b> Do not separate or remove shorting bars from RCM C2041.</li> <li>● Measure the resistance between RCM C2041 pin 6, circuit 607 (LB/OG), harness side and RCM C2041 pin 21, circuit 397 (BK/WH), harness side.</li> </ul>	<p><b>Yes</b> GO to <a href="#">F4</a>.</p> <p><b>No</b> INSTALL a new RCM. GO to <a href="#">F6</a>.</p>

**NOTE:** If a seat equipped with a seat mounted side air bag and/or a safety belt pretensioner (if equipped) system is being serviced, **the air bag system must be deactivated.**

**NOTE:** Restraint system diagnostic tools **MUST** be installed under the seats in the seat side air bag (if equipped) and safety belt pretensioner (if equipped) to floor connectors.

**NOTE:** Diagnostics or repairs are not to be performed on a seat equipped with a seat side air bag with the seat in the vehicle. Prior to attempting to diagnose or repair a seat concern when equipped with a seat side air bag, the seat must be removed from the vehicle and the restraint system diagnostic tools must be installed in the seat side air bag electrical connectors. **The restraint system diagnostic tools must be removed prior to operating the vehicle over the road.**

**NOTE:** After diagnosing or repairing an SRS, **the restraint system diagnostic tools must be removed before operating the vehicle over the road.**

**NOTE:** After diagnosing or repairing a seat system, **the restraint system diagnostic tools must be removed before operating the vehicle over the road.**

**NOTE:** The SRS must be fully operational and free of faults before releasing the vehicle to the customer.

1.  **WARNING:** To avoid accidental deployment and possible personal injury, the backup power supply must be depleted before repairing or replacing any front or side air bag supplemental restraint system (SRS) components and before servicing, replacing, adjusting or striking components near the front or side air bag sensors, such as doors, instrument panel, console, door latches, strikers, seats and hood latches.

Please refer to the appropriate vehicle shop manual to determine location of the front air bag sensors.

The side air bag sensors are located at or near the base of the B-pillar.

To deplete the backup power supply energy, disconnect the battery ground cable and wait at least one minute. Be sure to disconnect auxiliary batteries and power supplies (if equipped).

Disconnect the battery ground cable and wait at least one minute. For additional information, refer to [Section 414-01](#).

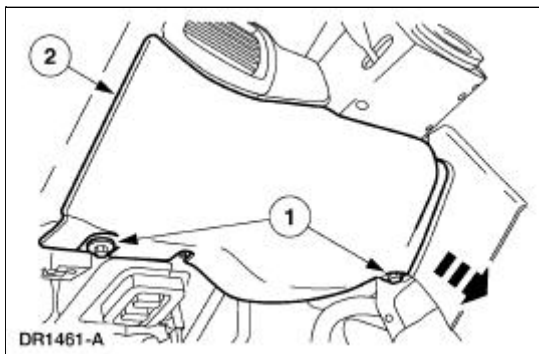

2. Remove the steering column opening lower finish panel.
  1. Remove the screws.
  2. Pull out to release the retaining clips and remove the steering column opening lower finish panel.



3. Remove the steering column opening lower reinforcement.
  1. Remove the bolts.
  2. Remove the steering column opening lower reinforcement.

## Front Subframe —3.8L Engine

### Special Tool(s)

 ST2333-A	3-Bar Engine Support Kit 303-F072
 ST2375-A	Lifting Bracket Set, Engine 303-D095 (D94L-6001-A) (014- 00792)

### Removal and Installation

#### All vehicles

1. Remove the steering gear. For additional information, refer to [Section 211-02](#).
2. Remove the lower control arms. For additional information, refer to [Section 204-01](#).

#### Vehicles with convertible top

3. Remove the front subframe support. For additional information, refer to [Subframe Support—Convertible](#) in this section.

#### Vehicles with hard top

4. Remove the front subframe brace.
  - Remove the bolts.

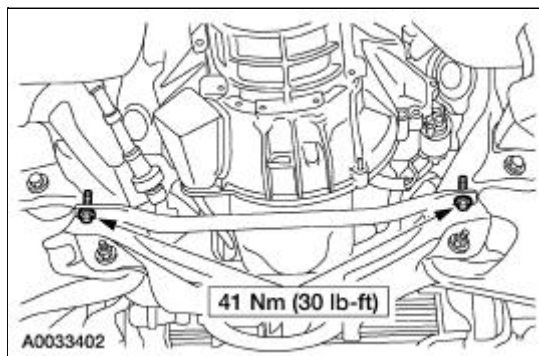

#### All vehicles

5. Lower the vehicle.

# 2003 Ford Mustang

## 2003 SYSTEM WIRING DIAGRAMS Ford - Mustang

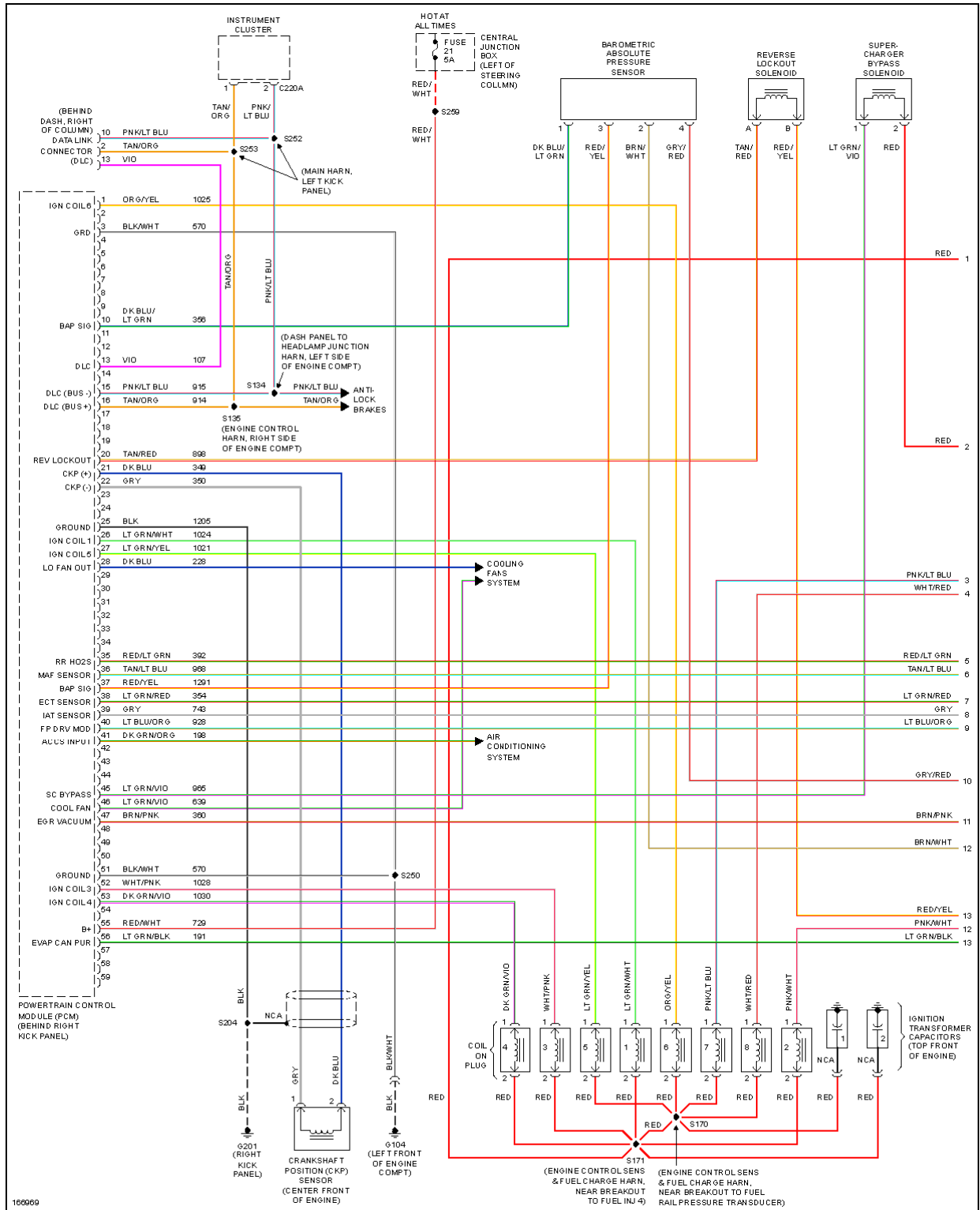

**Fig. 17: 4.6L SC, Engine Performance Circuit (1 of 3)**

# 2003 Ford Mustang GT

## 2003 SYSTEM WIRING DIAGRAMS Ford - Mustang

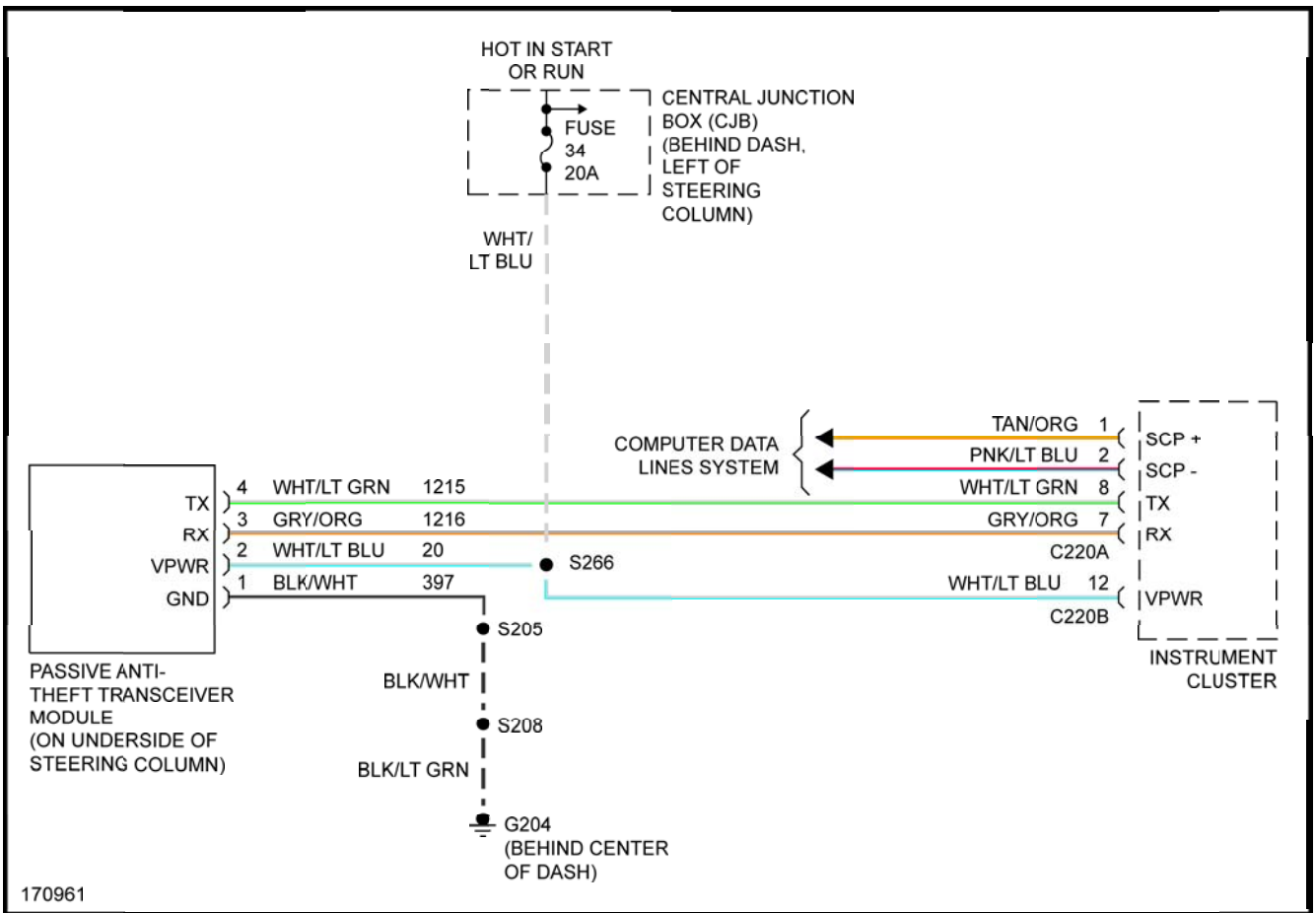

Fig. 4: Passive Anti-theft Circuit

### BODY CONTROL MODULES



CLICK HERE TO **DOWNLOAD** THE COMPLETE MANUAL

- Thank you very much for reading the preview of the manual.
- You can download the complete manual from: [www.heydownloads.com](http://www.heydownloads.com) by clicking the link below



- Please note: If there is no response to CLICKING the link, please download this PDF first and then click on it.

CLICK HERE TO **DOWNLOAD** THE COMPLETE MANUAL