

CLICK HERE TO **DOWNLOAD** THE COMPLETE MANUAL

- Thank you very much for reading the preview of the manual.
- You can download the complete manual from: www.heydownloads.com by clicking the link below



- Please note: If there is no response to CLICKING the link, please download this PDF first and then click on it.

CLICK HERE TO **DOWNLOAD** THE COMPLETE MANUAL



2 General

3.4.2 Structure of a job card

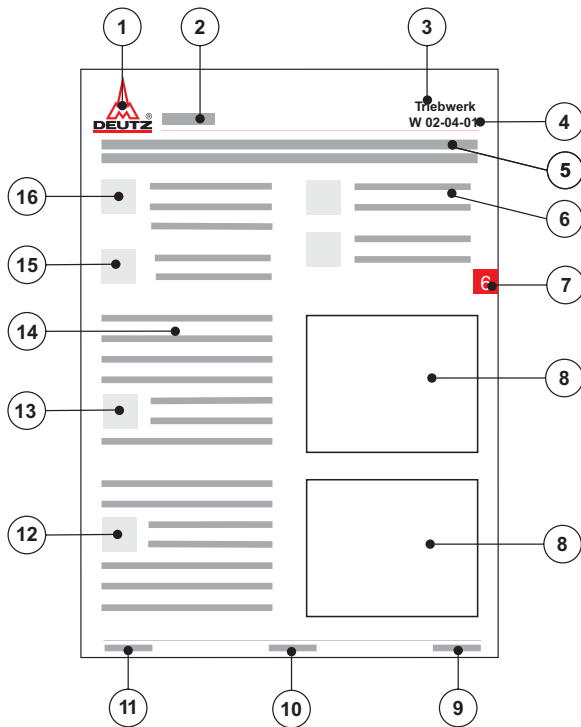

1. DEUTZ AG, publisher of service documentation
2. Engine type (e.g. TCD 2013 4V)
3. Maintenance group
4. Job card number or topic
5. Title of job card
6. Reference to other job cards
7. Chapter
8. Graphic or photo
9. DEUTZ internal creation number
10. Page number
11. Date of issue of job card
12. Note
13. Danger / Important
14. Work sequence
15. Special tools; auxiliary materials
16. Conventional tools

3.5 Explanation of symbols



Danger!

of death or to health. Must be observed! For example: The incorrect use or conversion of the turbocharger can lead to serious injury.



Caution!

Danger to the component/engine. Non-compliance can lead to destruction of the component/engine. Must be observed!



Note

General notes on assembly, environmental protection etc. No potential danger for man or machine.



Tool

Conventional and special tools required for the work.



Auxiliary materials

Working materials required in addition to the tools for performing the work (e.g. greases, oils, adhesives, sealants)



References

to important documents or job cards for the work process.

For example: Job card W 04-05-05



Reference

to a document or a job card within the work process.



Test and setting data

The necessary values are specified here. If several values are necessary, a cross reference is given to the Test and Setting Values table.

For example:

ID no. P01 61 = valve clearance, inlet



Tightening specification

The necessary values are specified here. If several values are necessary, a cross reference is given to the Tightening Specifications table.

For example:

ID no. A01 001 = cylinder head screws



TCD 2013 4V

**Technical data
Testing and setting data**

ID no.	Name	Information	Series	Value	Unit
Cooling system					
P09 11	Coolant thermostat, start of opening		TCD 2013	4V 86 +2 / +2	°C

ID no.	Name	Screw type	Notes / Remarks	Series		Pre-clamping value	Post-clamping value
A13 046	Pressure/temperature sensor on charge air line			TCD 2013	4V	7.5 Nm	
A13 051	Cable connection on injector			TCD 2013	4V	1.5 Nm	
A13 064	Slotted nut for cable plug	M28		TCD 2013	4V	9 Nm	
A13 064	Plastic nut for cable plug	M28		TCD 2013	4V	6 Nm	
A13 065	Cable connection on heating flange			TCD 2013	4V	20 Nm	
A13 071	Charge current cable on starter			TCD 2013	4V	15 Nm	
A13 073	Cable connection on starter relay			TCD 2013	4V	2.5 Nm	
A13 081	Charge current cable on generator B+			TCD 2013	4V	12 Nm	
A13 082	Cable D+ on generator			TCD 2013	4V	3 Nm	

Job card	Activity	Maintenance group
W 00-02-06	Checking the compression pressure	General
W 00-05-01	Mounting engine on assembly block and demounting	General
W 01-01-01	Checking and setting the valve clearance	Cylinder head
W 01-02-02	Removing and installing the valve control	Cylinder head
W 01-02-06	Dismantling and assembling the valve control	Cylinder head
W 01-04-04	Removing and installing the cylinder head	Cylinder head
W 01-04-09	Checking piston overhang	Cylinder head
W 01-05-01	Removing and installing the valves	Cylinder head
W 01-05-04	Checking the valves	Cylinder head
W 01-06-03	Checking the valve guide	Cylinder head
W 01-07-08	Checking the valve lag	Cylinder head
W 02-01-04	Checking the axial clearance of the crankshaft	Drive system
W 02-01-07	Checking the crankshaft	Drive system
W 02-02-02	Renewing the crankshaft sealing ring (flywheel side)	Drive system
W 02-02-04	Renewing the crankshaft sealing ring (opposite side to flywheel)	Drive system
W 02-04-01	Removing and installing the crankshaft	Drive system
W 02-09-03	Removing and installing the piston and con rod	Drive system
W 02-09-07	Checking the piston	Drive system
W 02-10-03	Checking the piston rings and piston ring grooves	Drive system
W 03-01-11	Removing and installing the crankcase bleeding	Crankcase
W 03-01-15	Dismantling and assembling the crankcase breather	Crankcase
W 03-03-01	Testing the cylinder liner	Crankcase
W 03-03-02	Removing and installing the cylinder liner	Crankcase
W 03-03-08	Checking the overhang of the cylinder liner	Crankcase
W 03-08-01	Removing and installing the front cover (opposite side to flywheel)	Crankcase
W 03-09-04	Removing and installing the connection housing	Crankcase
W 04-04-10	Removing and installing the gearcase	Crankcase
W 04-05-05	Removing and installing the camshaft	Engine control
W 04-05-06	Checking the camshaft	Engine control
W 05-07-01	Removing and installing the impulse transmitter (crankshaft)	Speed governing
W 05-07-03	Removing and installing the impulse transmitter (camshaft)	Speed governing
W 06-01-05	Removing and installing the exhaust line	Exhaust system / Charging

09 Cooling system (Forts.)

Job card	Activity and additional job cards necessary for its execution			
W 09-08-04	Removing and installing the thermostat housing			
	Operating Manual			
W 09-12-01	Removing and installing temperature transmitter			

12 Other components

Job card	Activity and additional job cards necessary for its execution			
W 12-01-04	Removing and installing torsional vibration damper			
	Operating Manual			
W 12-06-01	Removing and installing the flywheel			
W 12-10-01	Removing and installing the air conditioning compressor			
	Operating Manual			

13 Electrical system

Job card	Activity and additional job cards necessary for its execution			
W 13-02-03	Removing and installing the generator (operating side)			
	Operating Manual			
W 13-02-05	Removing and installing the generator (outlet side)			
	Operating Manual			
W 13-03-02	Removing and installing the starter			
W 13-08-01	Removing and installing pressure sensor/temperature sensor (charge air)			

Demounting engine from assembly block

- Hook the carrying chain in the transportation eyelets (arrows).



- Hang engine on workshop crane.

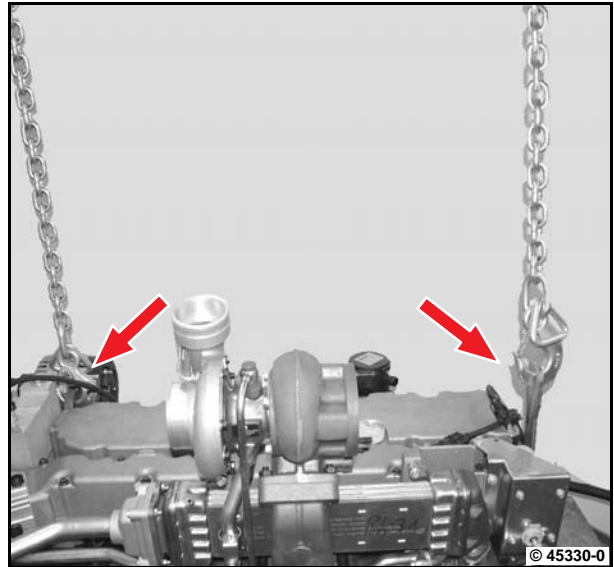

- Loosen lock nuts.
- Remove screws(3) and lock nuts.
- Unscrew screws (2).
- Remove clamping holder (1).

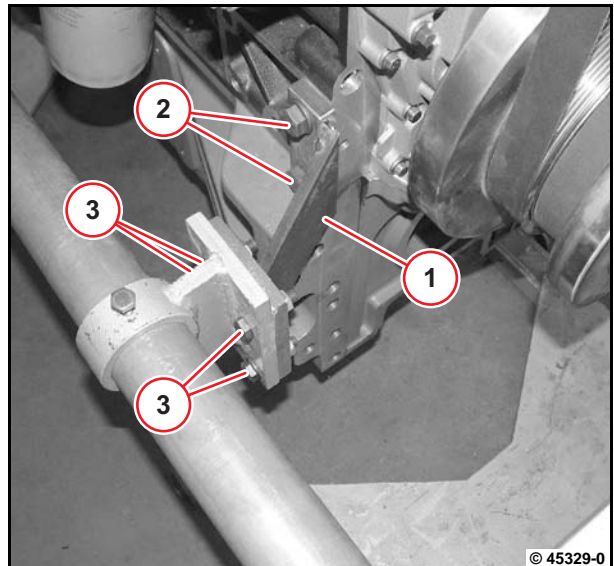

- Loosen lock nuts.
- Remove screws(3) and lock nuts.
- Unscrew screw (2).
- Remove clamping holder (1).

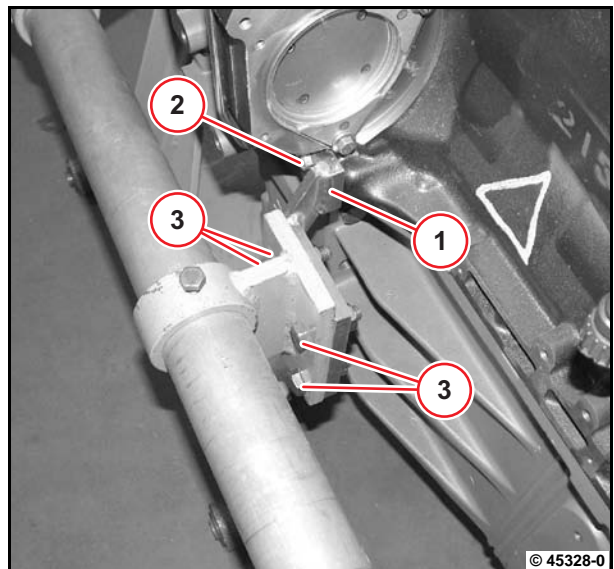

Removing and installing the valve control



Commercial available tools:
– Grooved nut wrench 6692



– W 01-01-01
– W 01-02-06

Removing the valve control

- Remove the cylinder head hood.
 W 01-01-01
- Bend back the lock latch (1).
- Unscrew the grooved nut with grooved nut wrench.

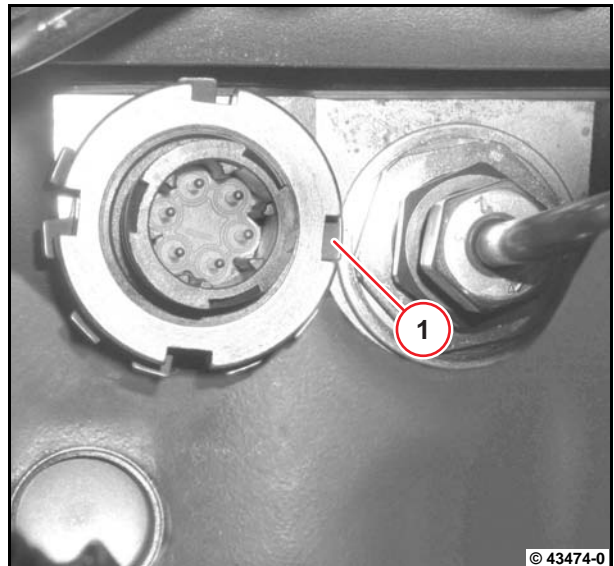

- Push cable plug inwards in the direction of the arrow.



Ensure that the cables do not buckle or get damaged.

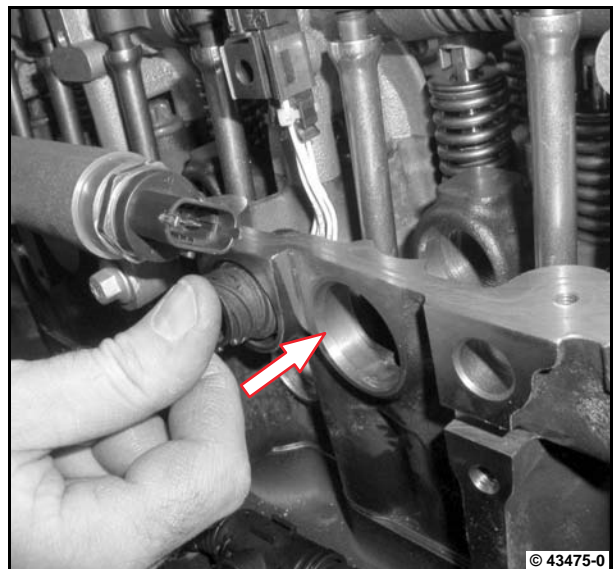

- Remove cylinder head gasket (1).

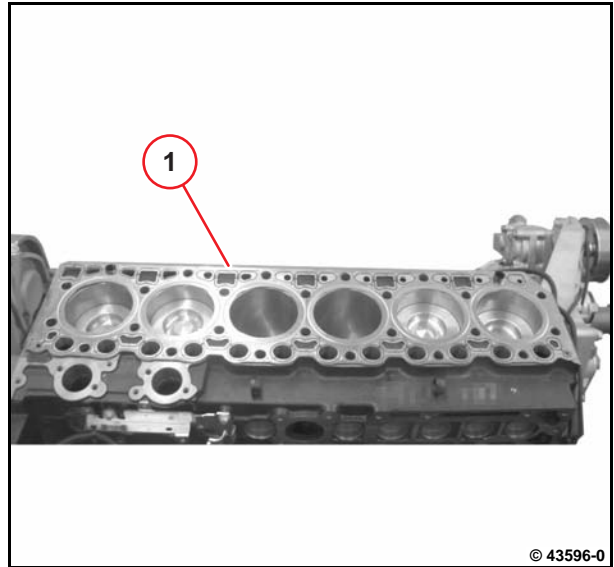

Installing the cylinder head

- Clean sealing surfaces.
- Measure the piston projection.

W 01-04-09

- Check valve stand back.

W 01-07-08

- Insert clamping bushing (1).

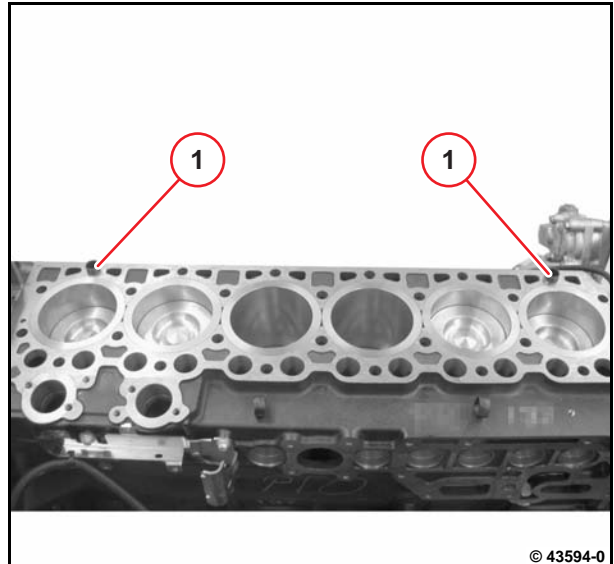

- Select cylinder head gasket according to the largest piston projection measured.

P02 75

P02 76

- Place on cylinder head gasket.



The sealing surfaces for the cylinder head gasket must be clean and free of oil.
Label OBEN / TOP facing the cylinder head.

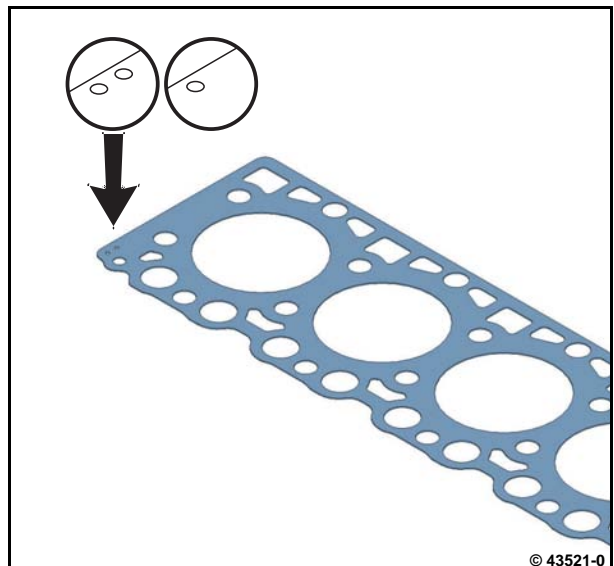

Checking the valves



Commercial available tools:
– Micrometer gauge
– Slide gauge



– W 01-05-01

Checking valve stem diameter

- Remove valves.



W 01-05-01

- Measure valve stem diameter with micrometer gauge.



P01 31

P01 32



Checking valve head diameter

- Measure valve head diameter with slide gauge.



P01 37

P01 38



Checking the crankshaft



- Commercial available tools:
- Magnetic measuring stand
 - Micrometer gauge
 - Internal measuring device
 - Prisms
 - Hardness tester

Special tools:

- Dial gauge. 100400



- W 02-04-01

Checking the bearing pin hardness

- Remove crankshaft.

W 02-04-01

- Place crankshaft on prism.
- Put hardness tester on journal.
- Raise stylus (1) and press release (2).



Stylus (1) falls down, briefly strikes the surface and jumps up to the measured value.

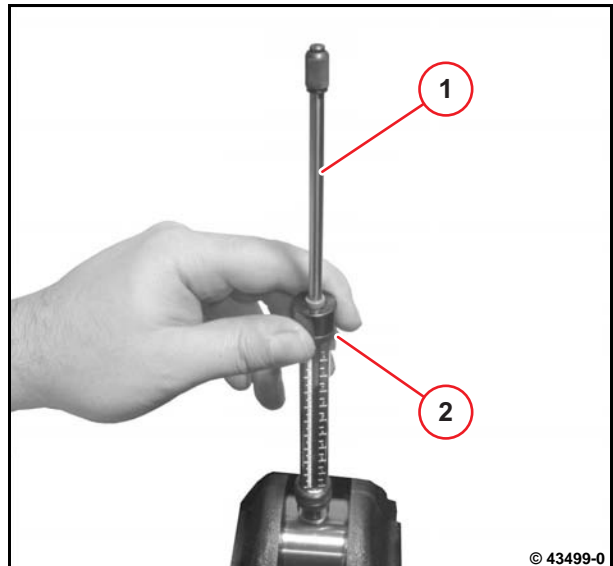

© 43499-0

- Read off displayed value (arrow) from hardness tester.

P02 07



The measured value is to be converted according to the table of the measuring device.

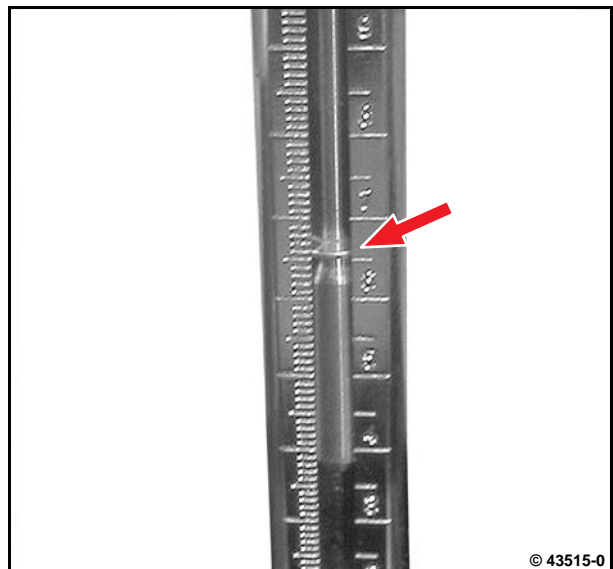

© 43515-0

- Pay attention to installation depth of crankshaft sealing ring and select shim accordingly.
 - First assembly = 2 shims
 - 1. Repair installation depth = 1 shim
 - Maximum installation depth = without washers

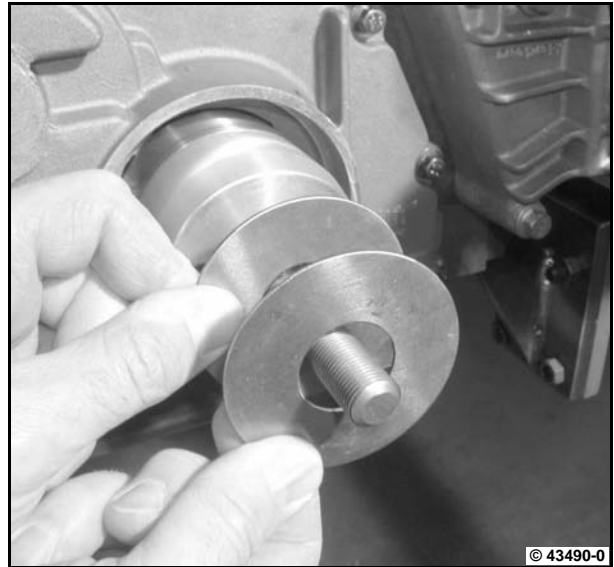

6

- Mount assembly sleeve.
- Press on the crankshaft sealing ring to the stop.



- Plug in the bearing (1).
- Screw on nut (2).
- Tighten nut to the stop of the assembly sleeve (3).



The crankshaft sealing ring is now at the pre-selected installation depth.

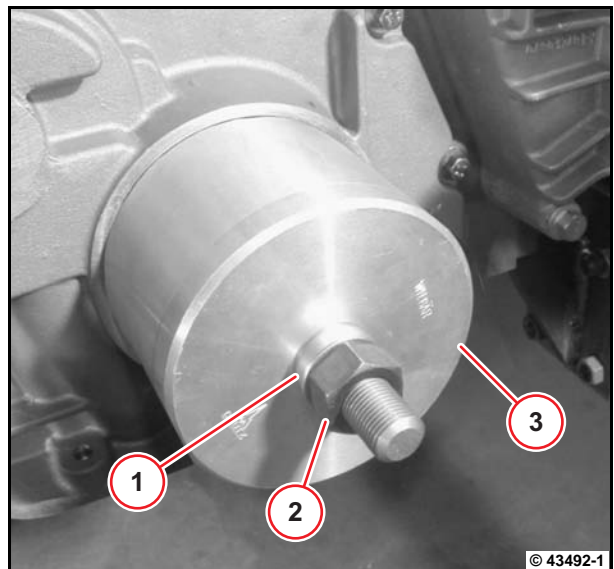

- Remove locking ring with locking ring pliers.
- Press out piston pin.
- Remove locking ring with locking ring pliers.

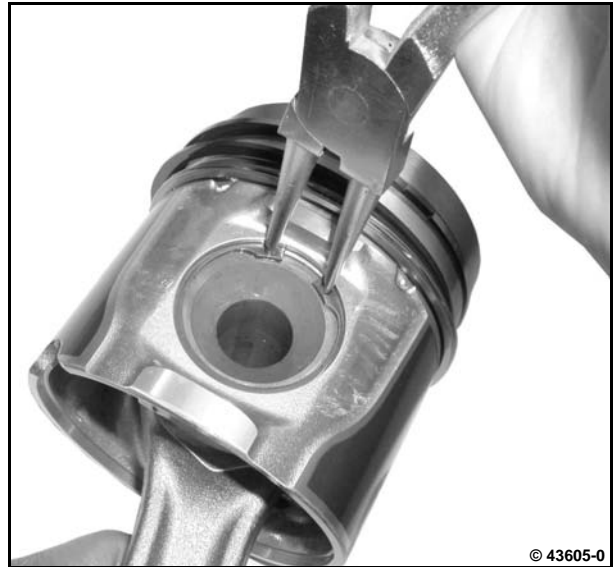

6

Installing the piston and con rod

- Install locking ring with locking ring pliers.

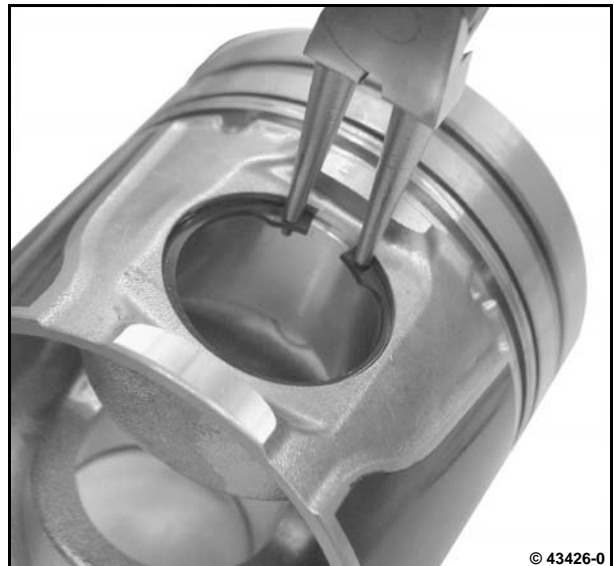

- Insert piston pin in piston.

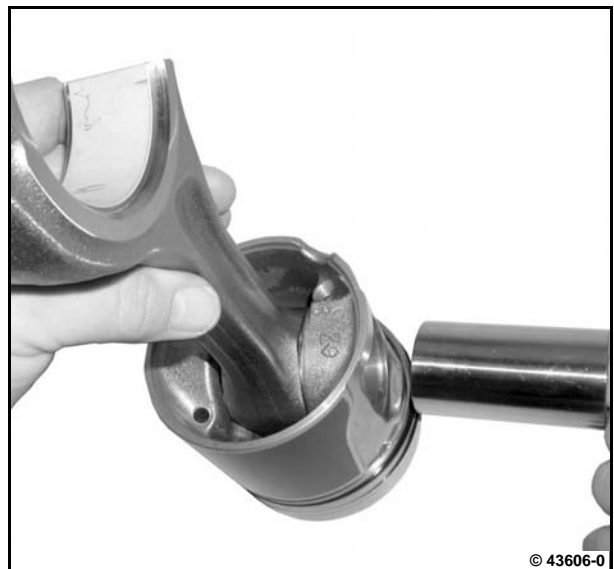

Checking the piston rings and piston ring grooves



Commercial available tools:

- Feeler gauges

Special tools:

- Universal piston ring pliers 130300
- Trapezoidal groove wear gauge 130420



- W 02-09-03

Checking the piston rings and piston ring grooves

- Remove piston from con rod.

W 02-09-03

- Set universal piston ring pliers to the piston diameter.
- Remove piston rings with universal piston ring pliers.

P02 71

- Clean piston.
- Visually inspect piston.



© 43421-0

- Measure piston ring groove for first piston ring with trapezoidal groove wear gauge.

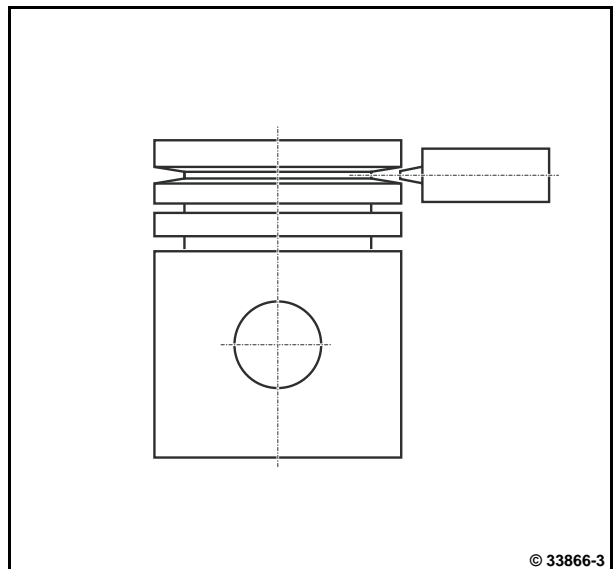

© 33866-3

- Clip on housing cover.



Ensure that the installation location is free from faults.



6

- Mount new O-ring (1).
- Lightly oil O-ring.



- Mount new O-ring (1).
- Lightly oil O-ring.



Removing and installing the front cover (opposite side to flywheel)



Commercial available tools



- W 02-02-04
- W 08-04-07
- W 12-01-04



- Packing compound
DEUTZ DW 67

Remove the front cover

- Removing torsional vibration damper.

W 12-01-04

- Remove lubricating oil pan.

W 08-04-07

- Unscrew screws (1).
- Unscrew screws (2).
- Remove front cover.

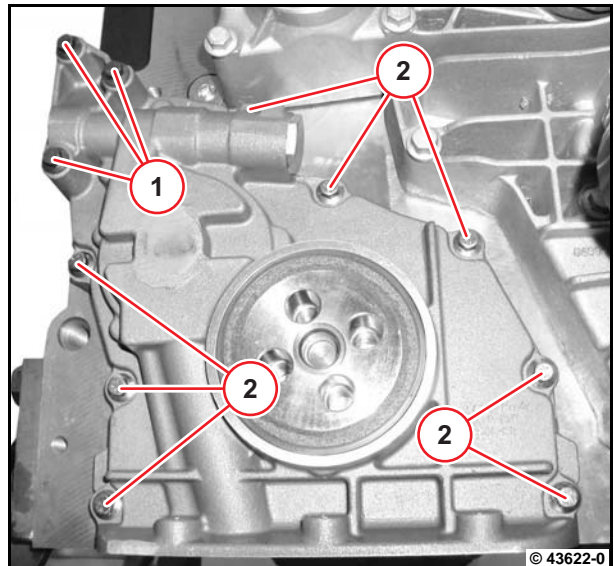

- Visually inspect the components.
- Knock out crankshaft sealing ring (1).



Attention!

Do not damage sealing surface when knocking out.

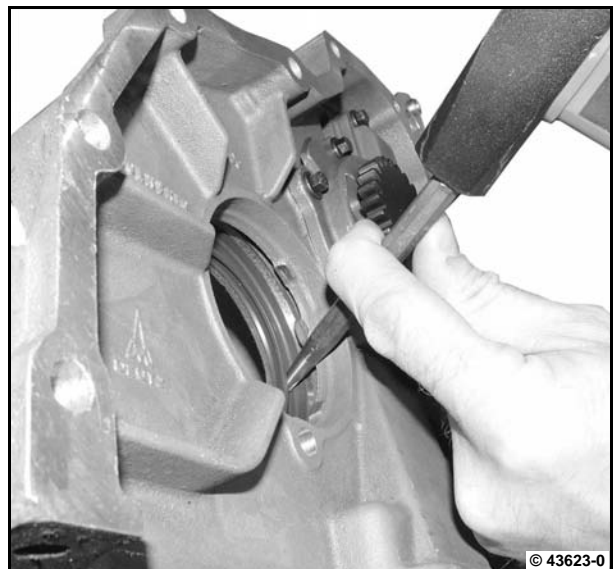

CLICK HERE TO **DOWNLOAD** THE COMPLETE MANUAL

- Thank you very much for reading the preview of the manual.
- You can download the complete manual from: www.heydownloads.com by clicking the link below



- Please note: If there is no response to CLICKING the link, please download this PDF first and then click on it.

CLICK HERE TO **DOWNLOAD** THE COMPLETE MANUAL

Installing the gearcase

- Clean sealing surfaces.



The sealing surfaces must be dry and free from grease and dirt.



© 45425-0

- Apply packing compound (arrow).



Attention!

The assembly must be completed within 1 hour at most.



Use packing compound DEUTZ DW 67. Sealing bead thickness approx. 1.4 mm.

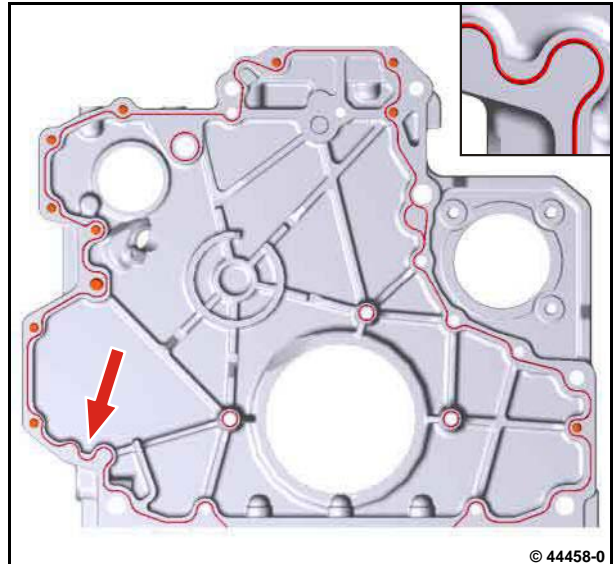

© 44458-0

- Press up gearcase cover and align flush with the oil tray sealing surface (arrows).



The oil tray sealing surface on the crankcase must face downwards.

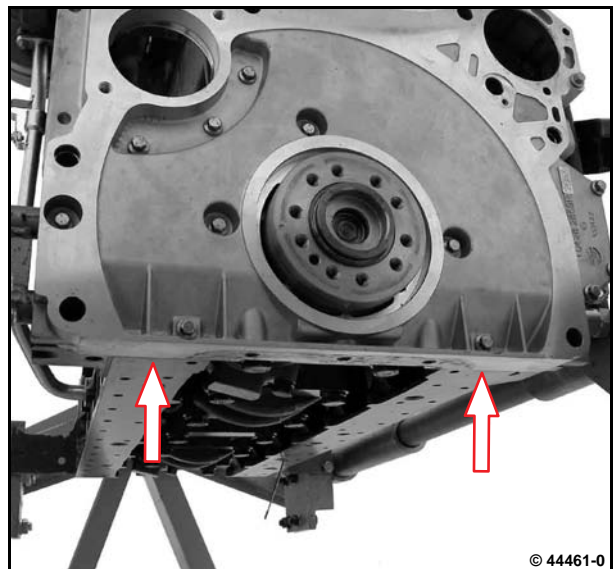

© 44461-0

Removing and installing the impulse transmitter (camshaft)



Commercial available tools

Removing the speed governor

- Unlock cable plug (1) and disconnect.

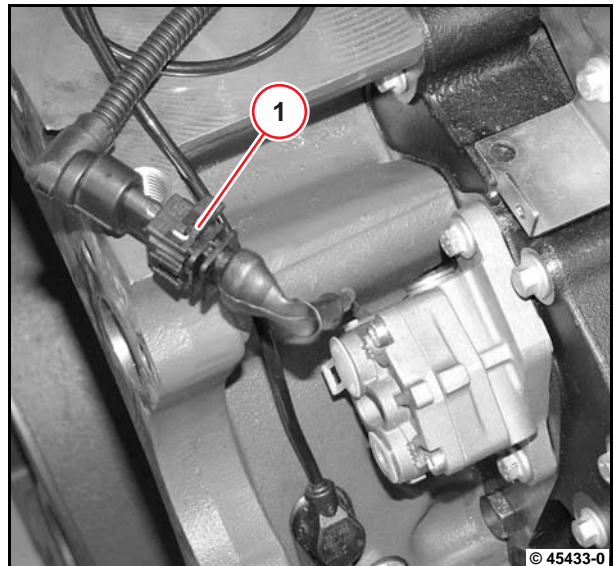

- Unscrew screw (1).
- Remove impulse transmitter (2).
- Clean sealing surfaces.
- Visually inspect the component.

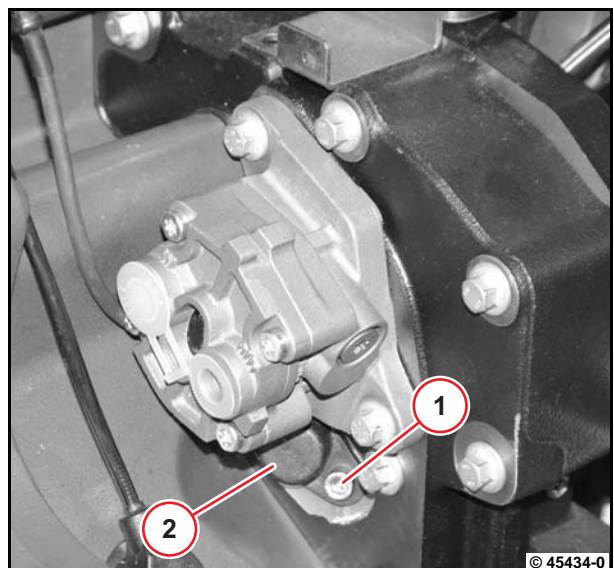

Remove and install the charge air line





Commercial available tools



- W 06-09-04
- W 06-09-05

Remove charge air line

- Remove cooler.
 W 06-09-04
- Remove actuator.
 W 06-09-05
- Unlock cable plug (1) and remove.

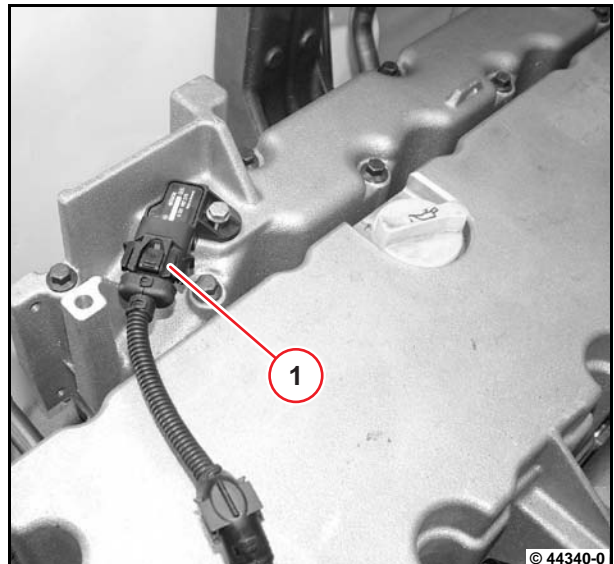

- Unscrew all screws.
- Remove charge air line (1).
- Remove gasket.

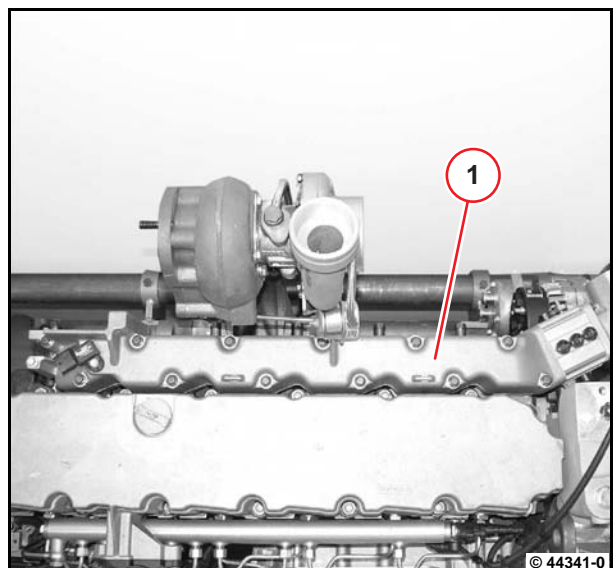

- Unscrew nuts (1).

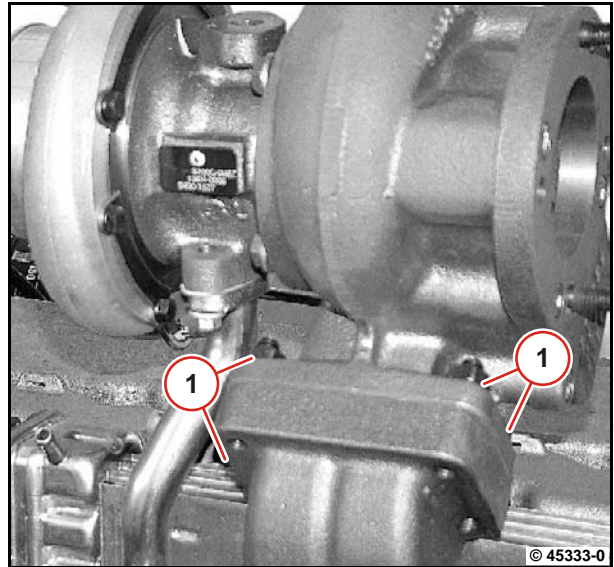

6

- Remove turbocharger (1).

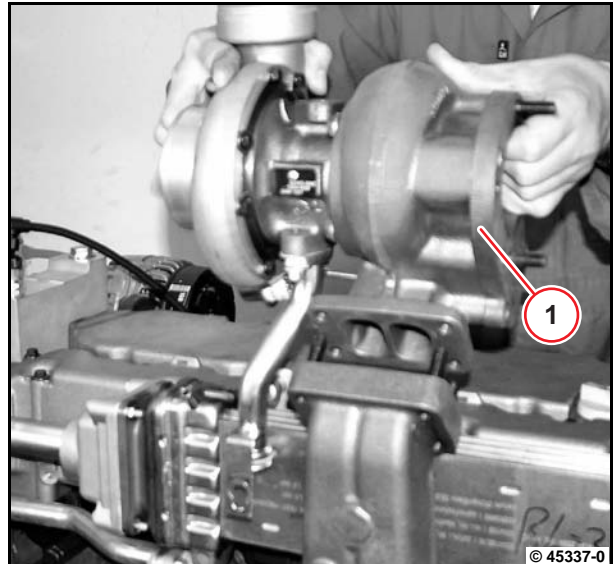

- Remove gasket.

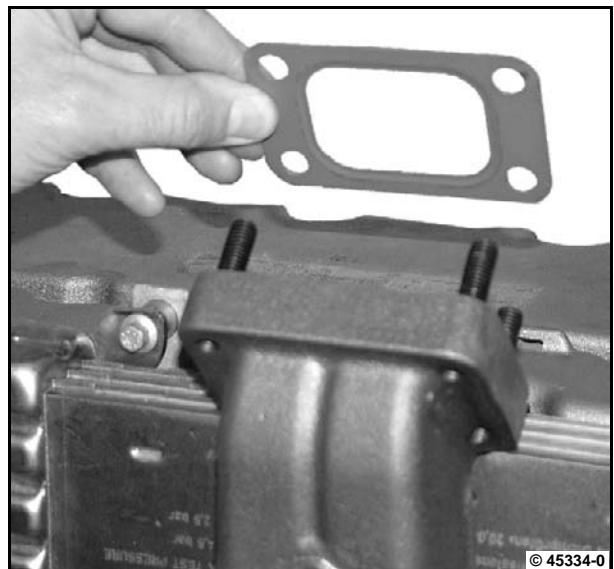

- Tighten screws (1).

 A06 061



Hold nuts (arrows).

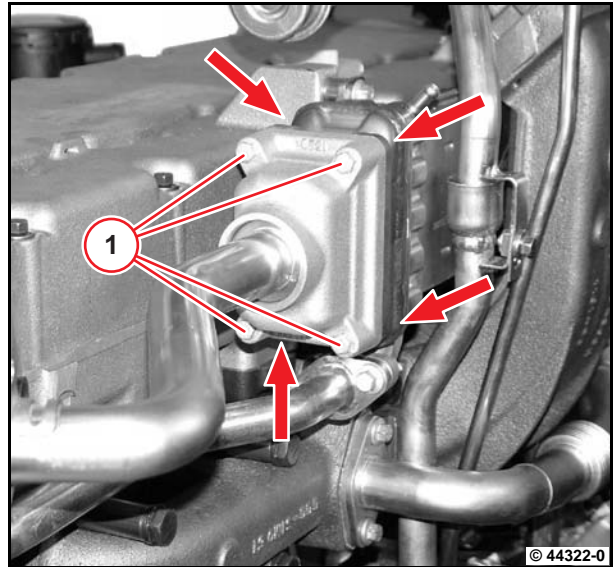

- Tighten screw (1).

 A06 064

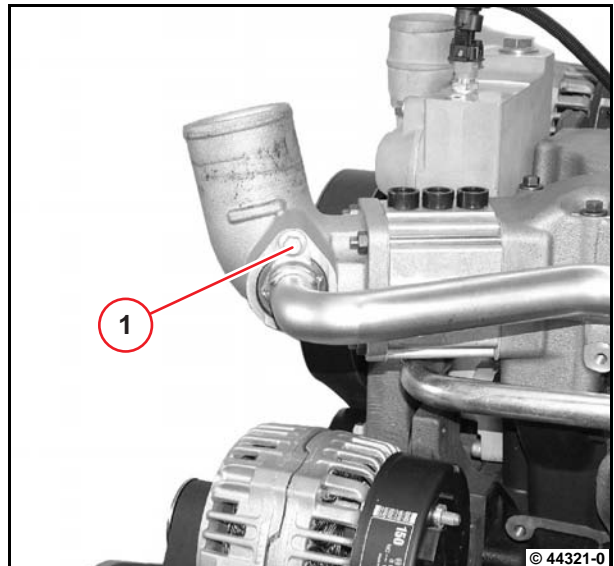

Removing and installing the shutoff valve (exhaust gas recirculation)



Commercial available tools

Removing the shutoff valve

- Unscrew the adjusting bar (1).
- Unscrew screws (2).
- Unscrew nuts (3).
- Remove pipe (4).

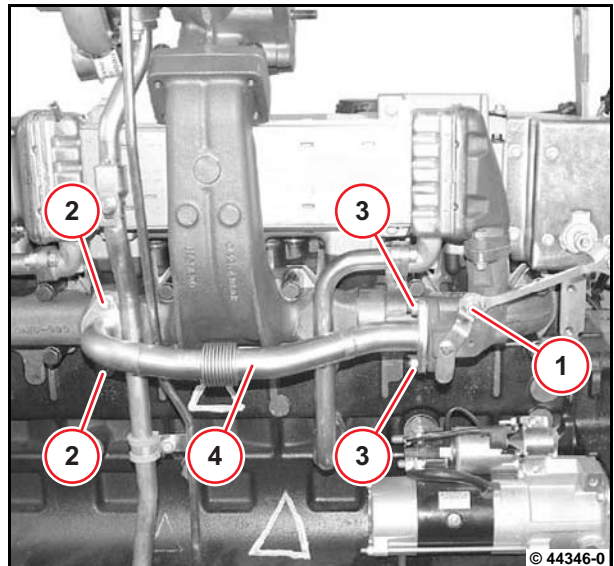

- Remove gasket (1).

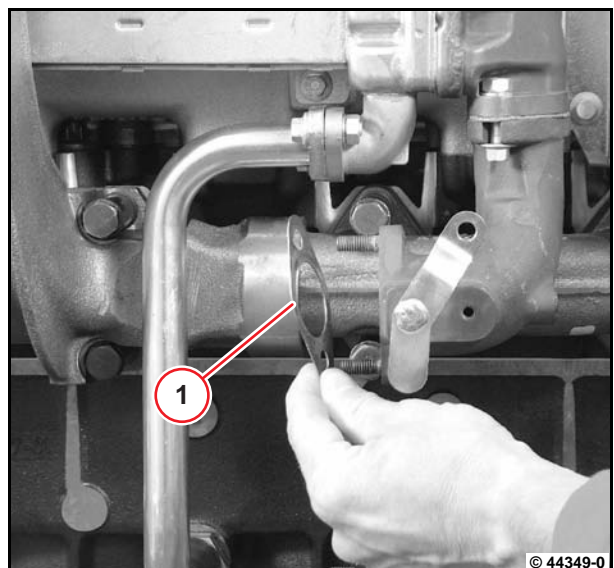

Removing and installing the high-pressure pump (Installation position A)



Commercial available tools:

- Socket wrench set
10 mm, 12-side

Special tools:

- Turn-over gear 100370
- Assembly pliers. 103220
- Special wrench 110500
- Assembly case with
assembly sleeves, guides
and disassembly tool 110900
- Plugs/caps 170160



- Fitting compound
DEUTZ AP1908



- User notes



Danger!

Wait 30 seconds after switching off the engine before working on the fuel system.



Attention!

Ensure utmost cleanliness when working on the fuel system. Carefully clean the area around the affected parts. Blow damp areas dry with compressed air. Observe the safety regulations and national specifications for handling fuels. Close all connections immediately after opening with new, clean plugs/caps. Do not remove plugs/caps until immediately before assembling. Collect leaking operating fluids in suitable vessels and dispose of according to regulations.

Removing the high-pressure pump



Danger!

Wait 30 seconds after switching off the engine before working on the fuel system.

- Unscrew screws (1).
- Remove cover (2).

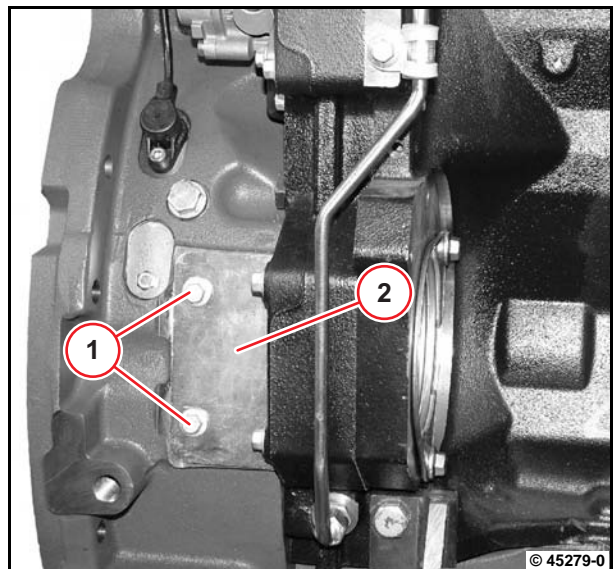

- Unscrew hollow screws (3).
- Remove fuel pipe and sealing rings.
- Remove injection pipe (2) with special wrench.
- Remove high pressure pipe (1) with special wrench.



Support the pipe connection of the high pressure pump.

Collect draining fuel and dispose of according to regulations.

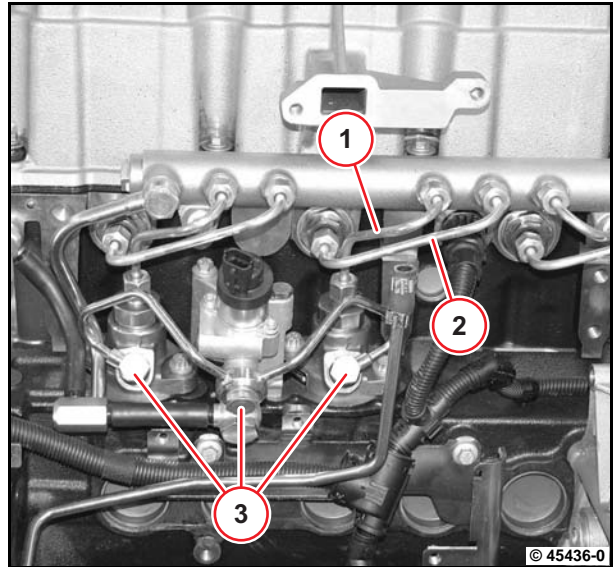

- Loosen screws (1).



Loosen screws evenly to avoid jamming the high-pressure pump.

If necessary, turn the crankshaft with turn-over gear in the direction of rotation of the engine until the high-pressure pump is felt to release.

- Unscrew screws (1) evenly.
- Remove high pressure pump.

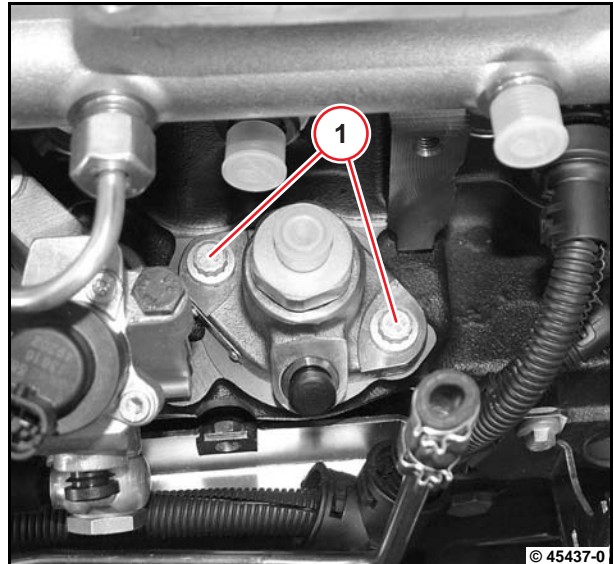

- Carefully remove the O-ring (1) from the high-pressure pump with the disassembly tool.



Attention!

Do not damage the high-pressure pump.

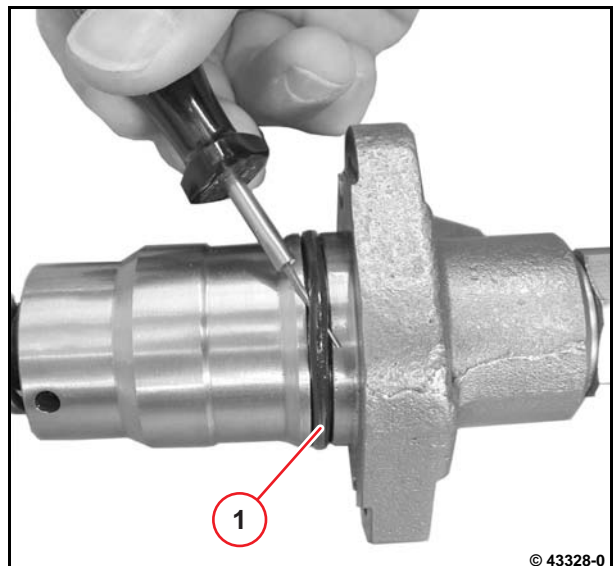

- Tighten all injection pipes on the rail (1) and on the pressure pipe nozzles with a special wrench.

 A07 003



Attention!

Install injection pipes without tension!

- Check the injection pipes for perfect installation position.

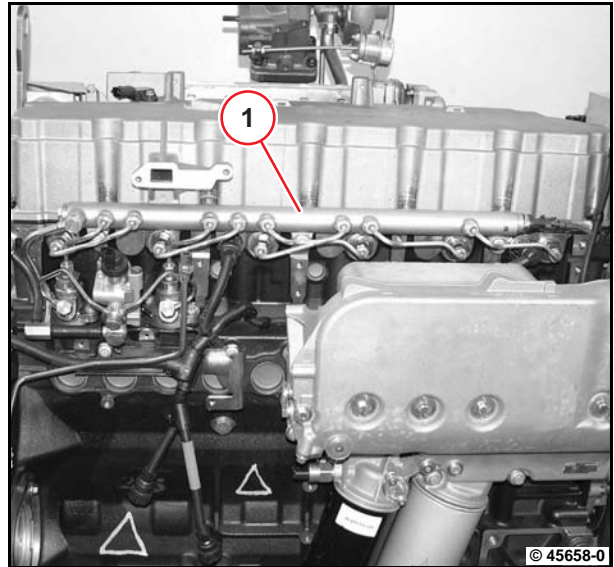

- Tighten high pressure pipes (2) with special wrench.

 A07 003



Attention!

Install high pressure line without tension.

- Check the high-pressure line for perfect installation position.
- Tighten hollow screw (1).

 A07 045

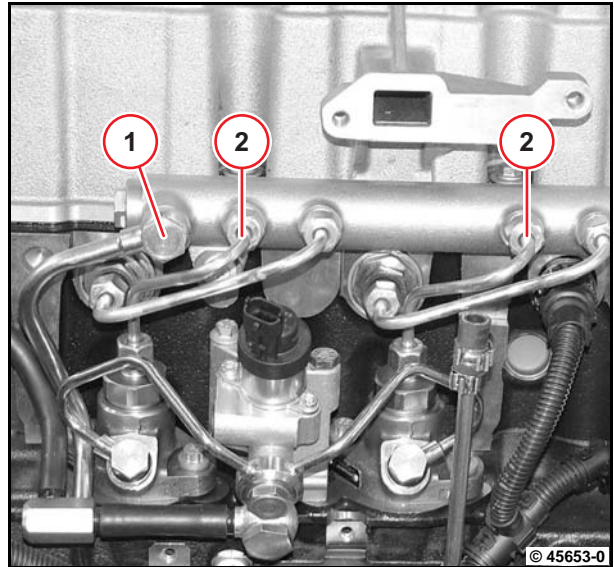

- Plug in the cable plug (2).
- Install crankcase breather (1).

 W 03-01-11



Bleed the fuel system via the manual fuel pump on the fuel pre-filter according to the operation manual.

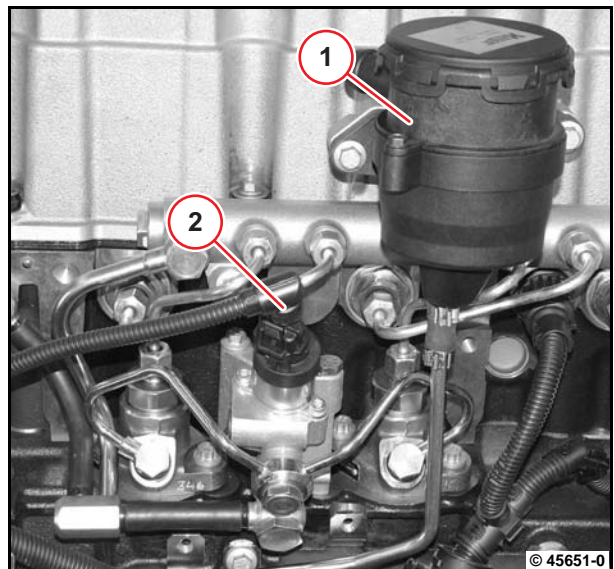

- Tighten screw (1).
- Post-clamping value:

 A07 001

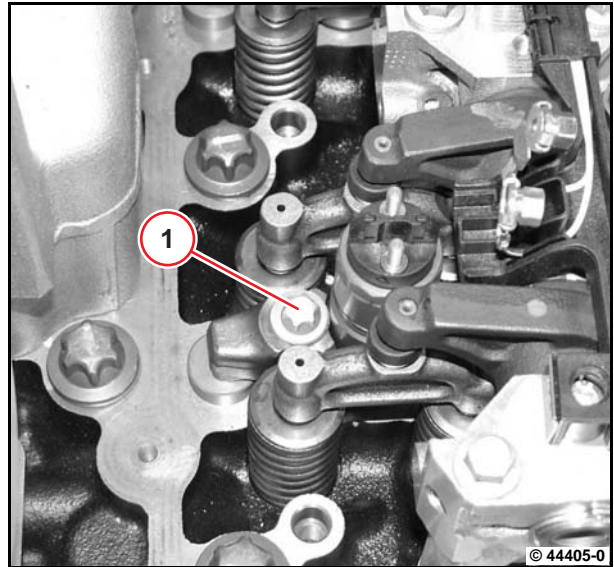

- Tighten pressure pipe nozzle with union screw (1).
- Post-clamping value:

 A07 036

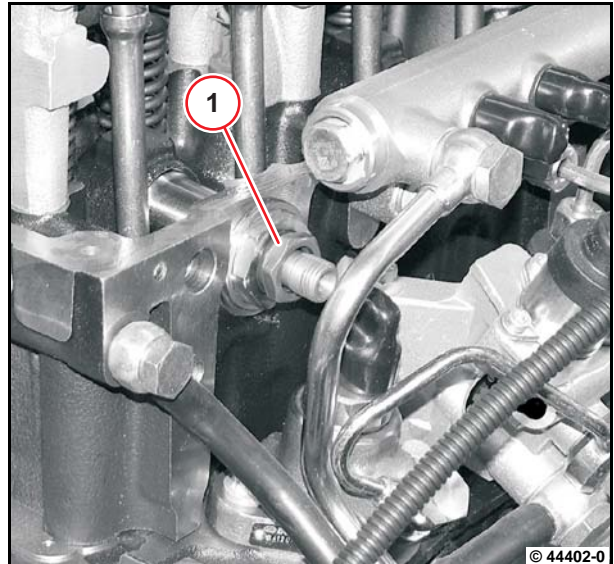

 **Attention!**
The high-pressure line must always be renewed after disassembly.

- Install new high pressure pipe (1).
- Tighten union nuts with special wrench.

 A07 003

 **Attention!**
Install high pressure line without tension.

- Check the high-pressure line for perfect installation position.

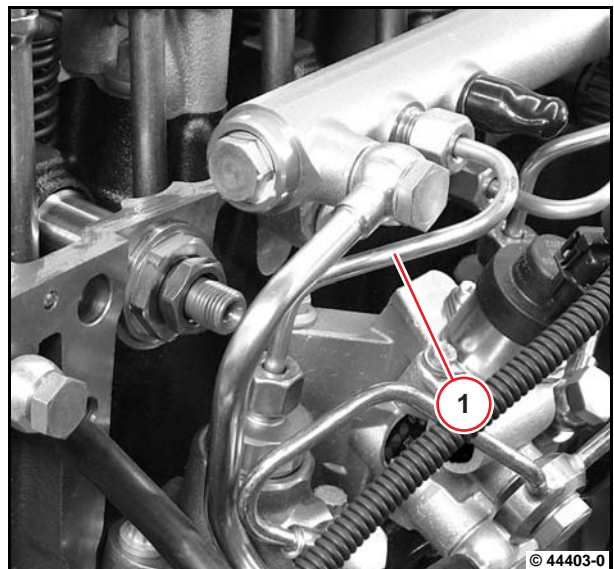

Removing and installing the lubricating oil pan (heavy duty version)



Commercial available tools:
– 4 pin bolts M8x70



– Packing compound
DEUTZ DW 74



Collect leaking operating substances in suitable vessels and dispose of according to regulations.
The engine oil should be filled according to the operating manual.

Removing the lubricating oil pan

- Remove oil dipstick.
- Remove screw cap.
- Drain, collect and dispose of engine oil according to regulations.
- Turn the engine on the assembly block.
- Unscrew all screws (1).
- Unscrew all screws (2).
- Lift the lubricating oil pan with the workshop crane.

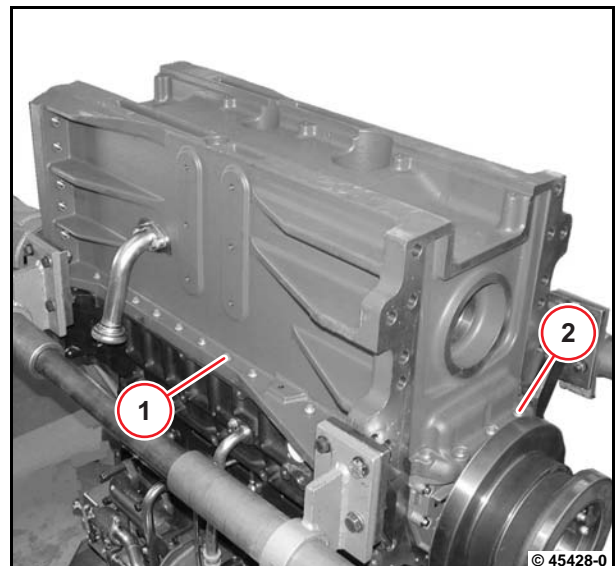

Installing the lubricating oil pan

- Clean sealing surfaces.
-  The sealing surfaces must be dry and free from grease and dirt.
- Mount new gaskets (1).

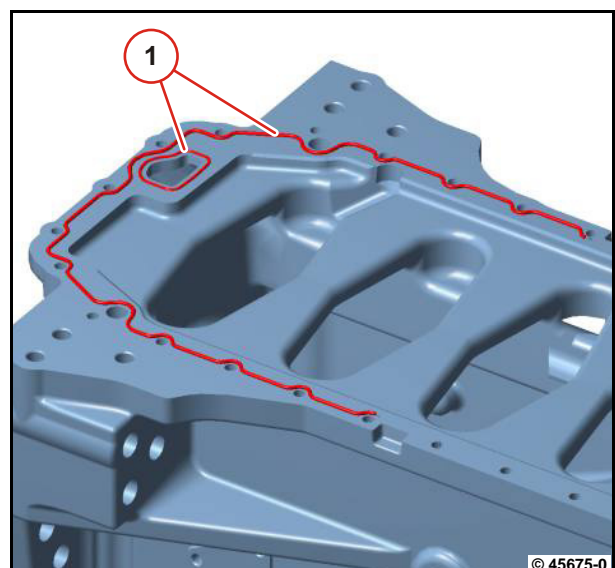

- Mount new gasket (1).
- Tighten screws (2).



The gasket is stopped by the screw thread.

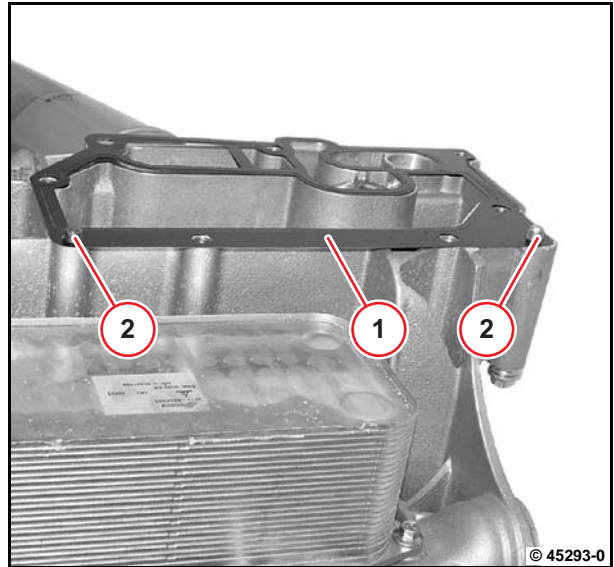

6

- Mount oil cooler housing.
- Fasten all screws.
- Tighten the screws according to the tightening sequence.

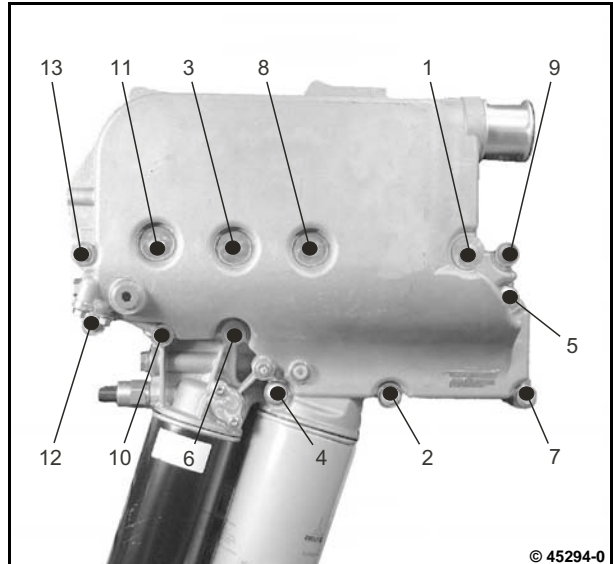

- Tighten screws .
 - (Items 1, 4):
 A08 050
 - (Items 2, 3):
 A08 051

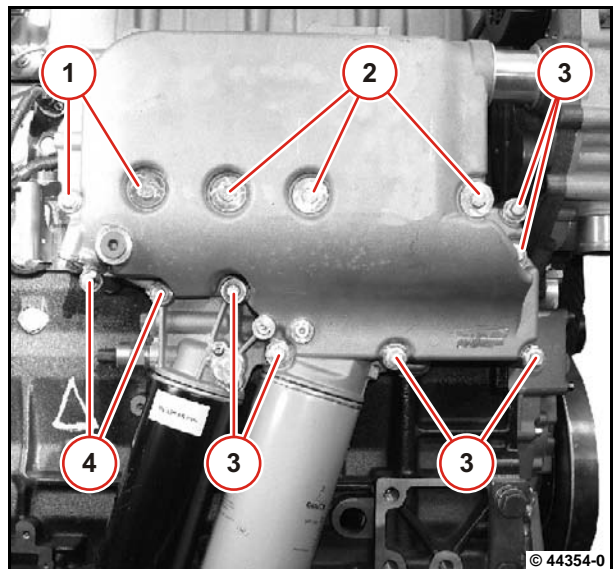

Removing and installing the thermostat



Commercial available tools



– Operation manual



Collect leaking operating substances in suitable vessels and dispose of according to regulations.

The appropriate documentation of the vehicle/equipment manufacturer should be observed for emptying and filling the cooling system.

Removing the thermostat

- Unscrew locking screw (1).
- Drain, collect and dispose of coolant according to regulations.

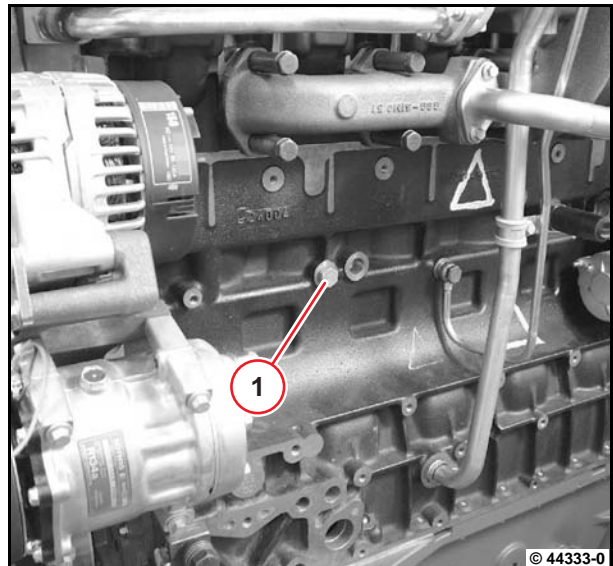

- Check the wear limit of the V-rib belt.

 Operation manual

- Relieve the V-rib belt tension with the belt tightener.
- Insert holding pin (1).
- Mark the running direction of the V-rib belt.
- Remove V-rib belt.

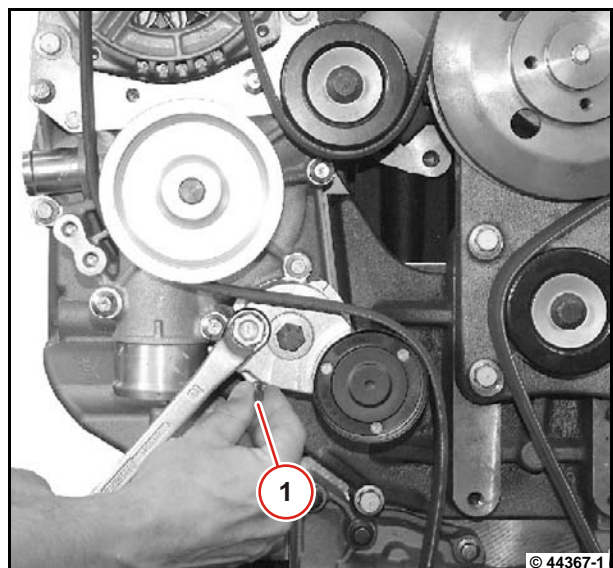

- Push on coolant pipe.
- Tighten screw (2).
-  A09 080
- Tighten pipe clip (1).

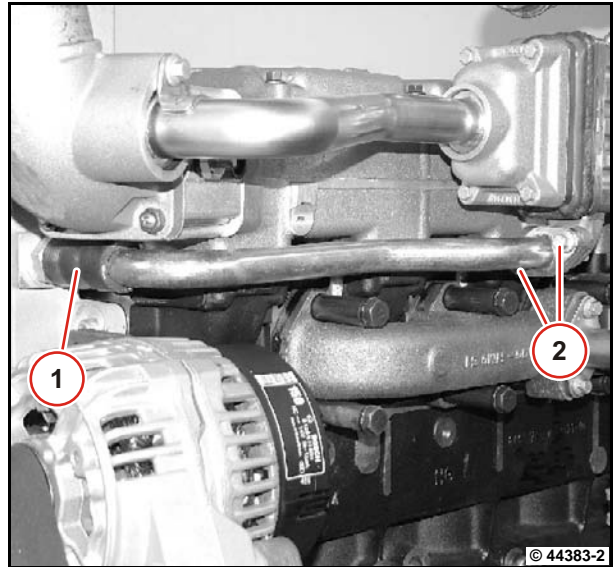

- Plug cable plug (1) onto temperature transmitter.

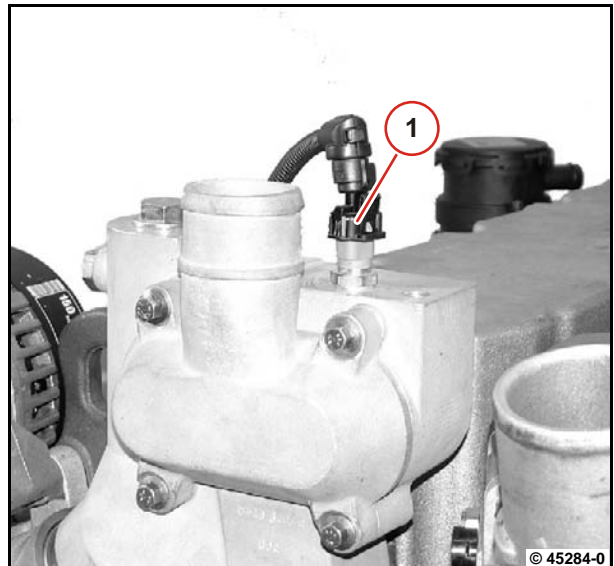

- Install fan mounting (2).
- Tighten screws (1).
-  A09 010

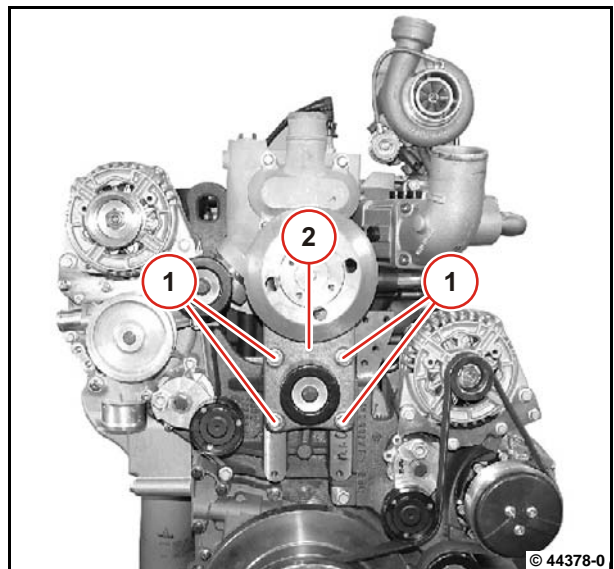

Removing and installing the flywheel



- Commercial available tools:
- Rotation angle disc 8190
 - Self-made mandrin guide
 - Auxiliary screws

Removing the flywheel

- Unscrew screws (1).
- Remove cover (2).

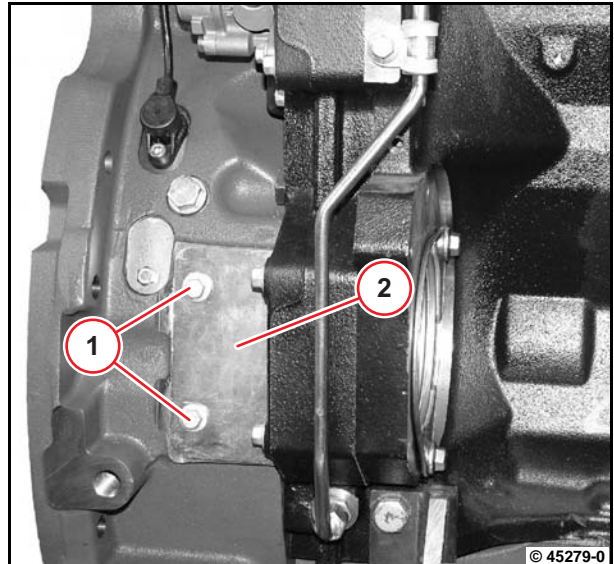

- Insert turn-over gear (1).
- Tighten screw (2).

 A03 085

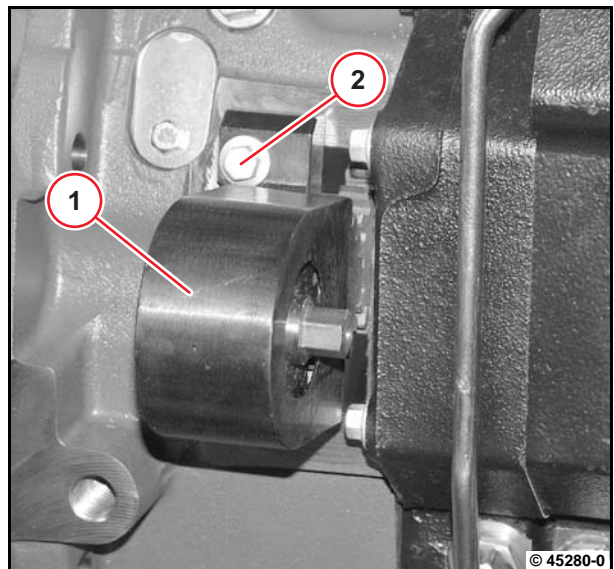

Removing and installing the generator (operating side)



Commercial available tools



– Operation manual

Removing the generator

- Disconnect the battery's negative terminal.
- Remove cable from generator.



Note assignment!

- (1) = terminal W
- (2) = terminal D+
- (3) = terminal B+

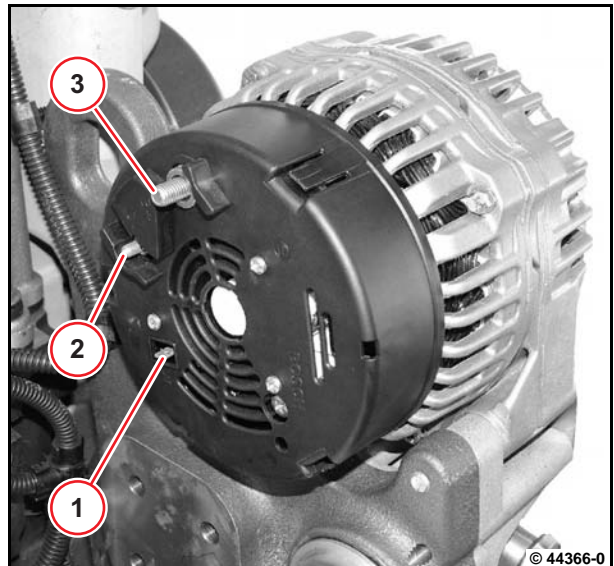

- Check the wear limit of the V-rib belt.



Operation manual

- Mark the running direction of the V-rib belt.
- Relieve the V-rib belt tension with the belt tightener.
- Insert holding pin (1).
- Remove V-rib belt.

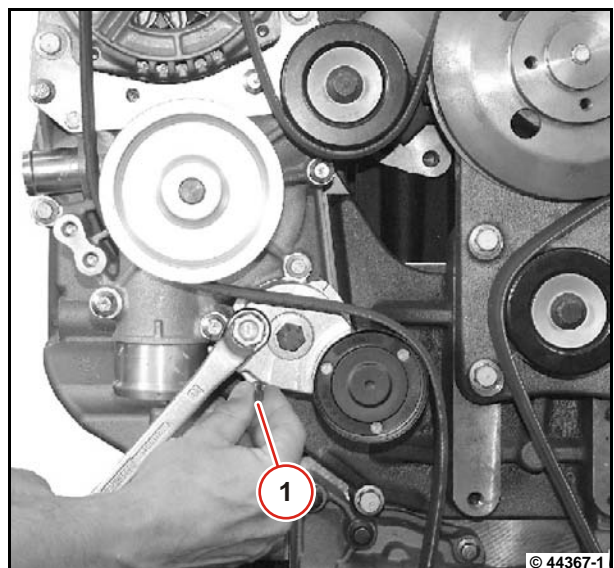

- Plug charging current cable to connection (1).

 A13 071

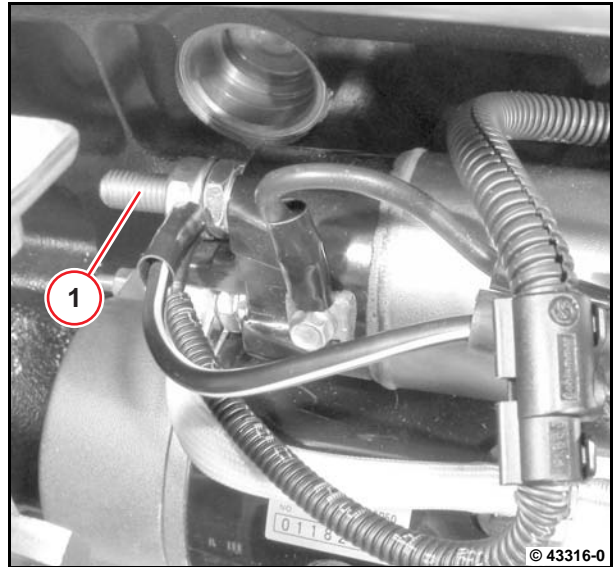

6

- Fix cable (1) to relay.

 A13 073

- Connect the battery.

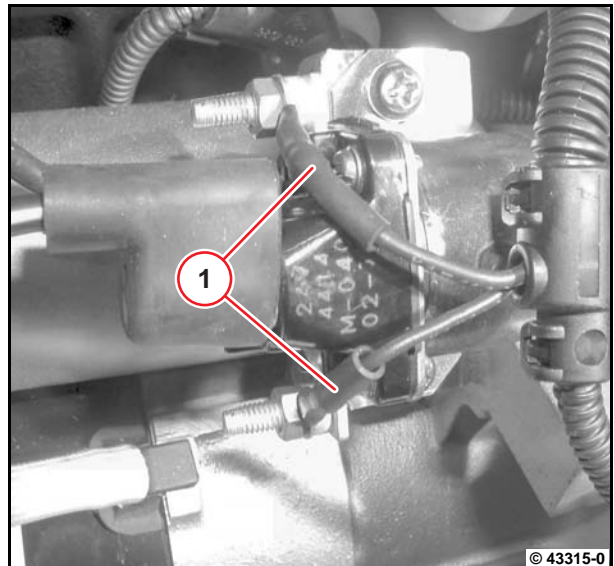

8196

Open end wrench adapter

Size 13,
for torque wrench
Tighten lock nut of the valve clearance setting screw.

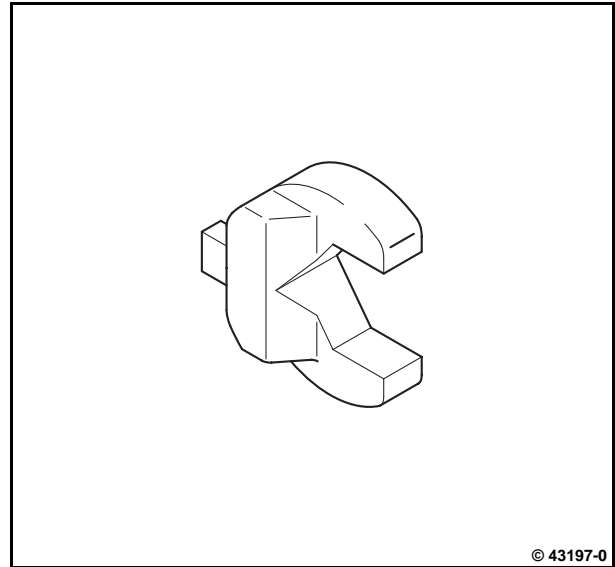

8198

Pricker

Removing rotary shaft lip seal



9090

Spring band pliers

320 mm
Tighten spring clamp

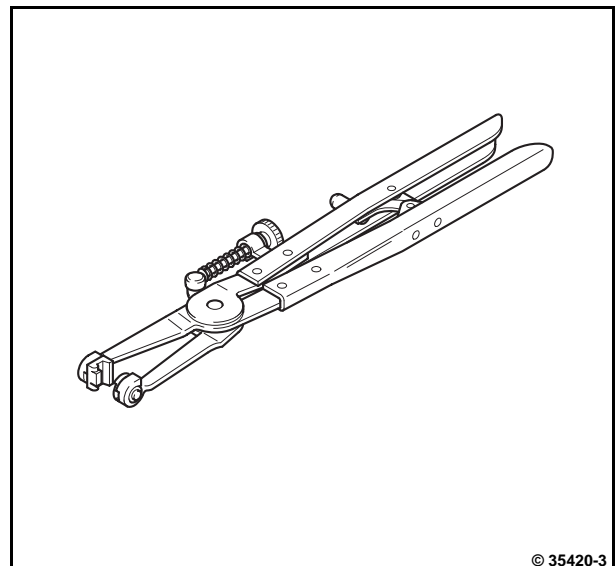

CLICK HERE TO **DOWNLOAD** THE COMPLETE MANUAL

- Thank you very much for reading the preview of the manual.
- You can download the complete manual from: www.heydownloads.com by clicking the link below



- Please note: If there is no response to CLICKING the link, please download this PDF first and then click on it.

CLICK HERE TO **DOWNLOAD** THE COMPLETE MANUAL