

Workshop manual

AV 70 X Cummins

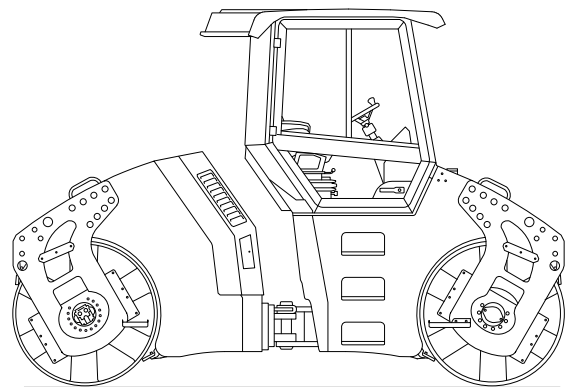

CLICK HERE TO **DOWNLOAD** THE COMPLETE MANUAL

- Thank you very much for reading the preview of the manual.
- You can download the complete manual from: www.heydownloads.com by clicking the link below



- Please note: If there is no response to CLICKING the link, please download this PDF first and then click on it.

CLICK HERE TO **DOWNLOAD** THE COMPLETE MANUAL

SYMBOLS OF THE SAFETY NOTICES:



The notice warns of a serious risk of personal injury or other personal hazards.



The notice warns of possible damages to the machine or its parts.



The notice warns of the necessity of environmental protection.

! CAUTION !

This Manual uses the terms like RH, LH, in the front, in the rear. These indicate the sides of the Machine viewed during forward drive.

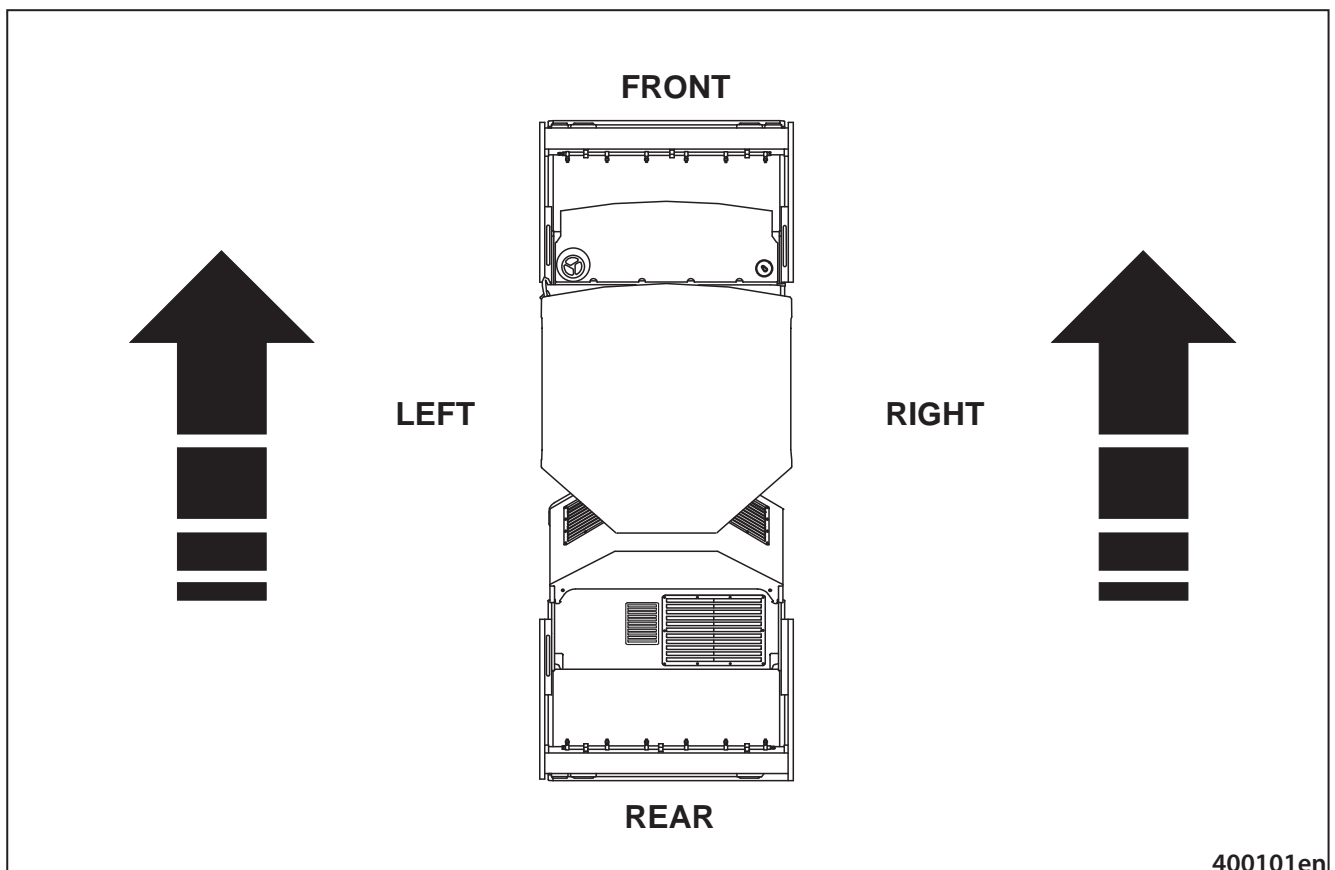

400101en

3. Machine Description

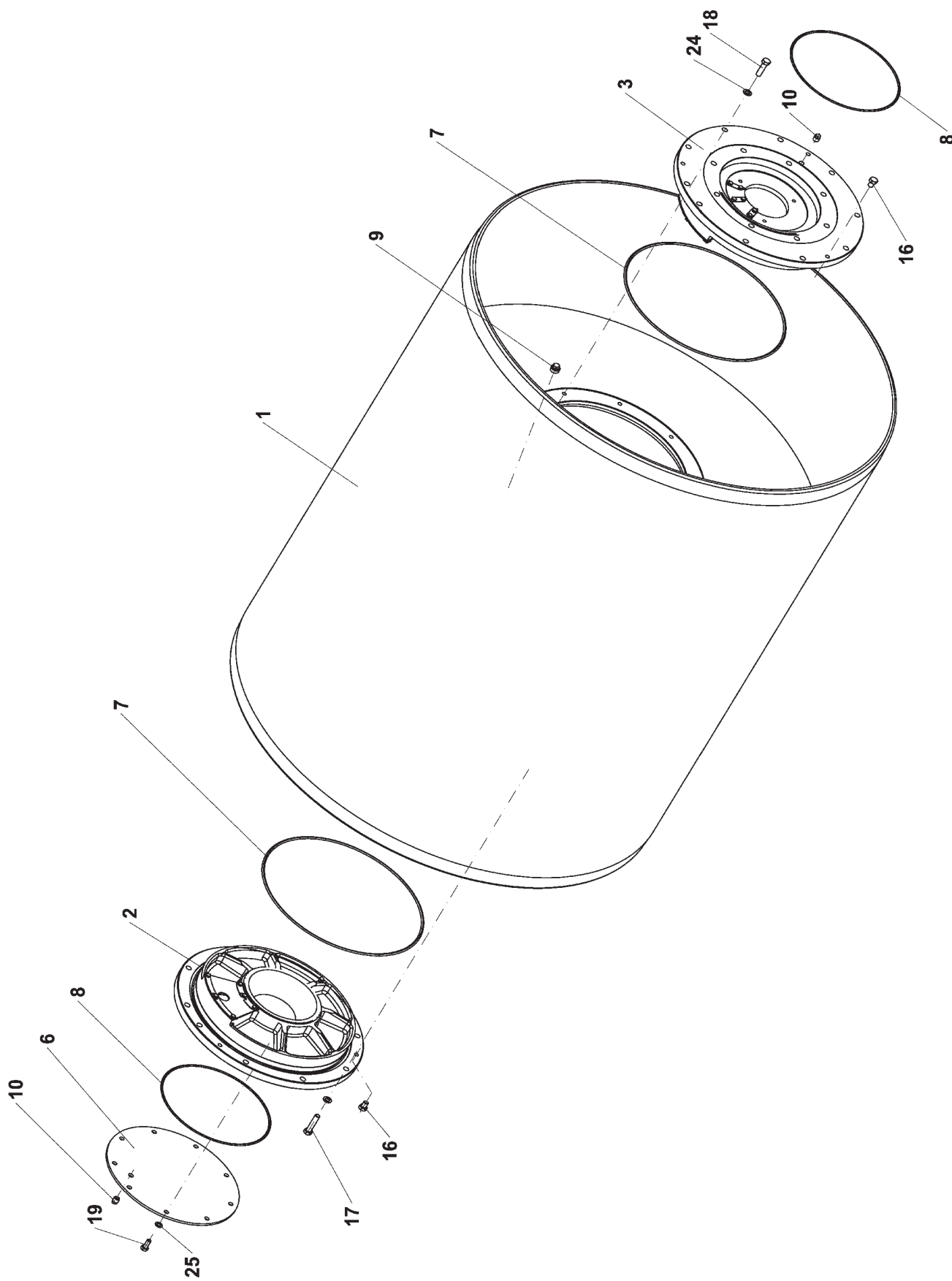

400A174

Remove oil filler and drainer, mark the position and remove bolts used to mount aux. transmission 11 to carrier 5, take off the carrier.

Note

When reinstalling, please clean contact surfaces, tighten bolts 28 with 200 Nm torque.

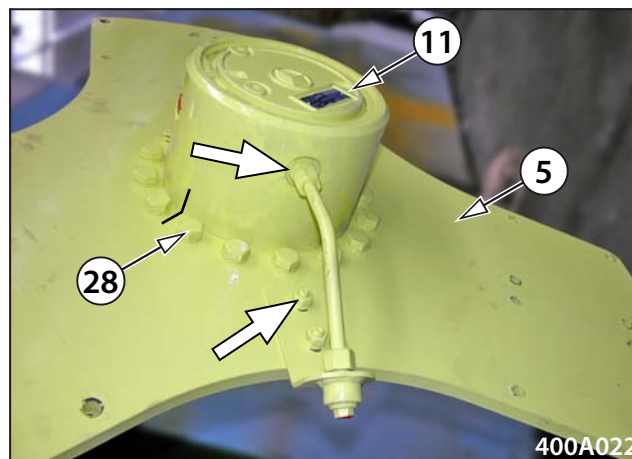

4.4. Remove front drum

The removal procedure is identical for front drum and rear drum.

Use hand jack to lift a bit the Machine on its LH side and RH side so the drum contacts lightly the ground, put under the supports of sufficient loading capacity.

Mark drum position, on both sides for reinstallation purposes.

RH side:



Put oil pan under hydromotor.

Disconnect revolution sensor pickup connector.



Release locking sheet 16.

Use fixture No. 5 to remove KM nut 15.

Use puller to pull down inner ring for bearing 13 and ring 9.

Take off rings 7.

Note

Vibrator, i.e. shaft 6 complete with eccentrics 1, 2, is one-piece unit.

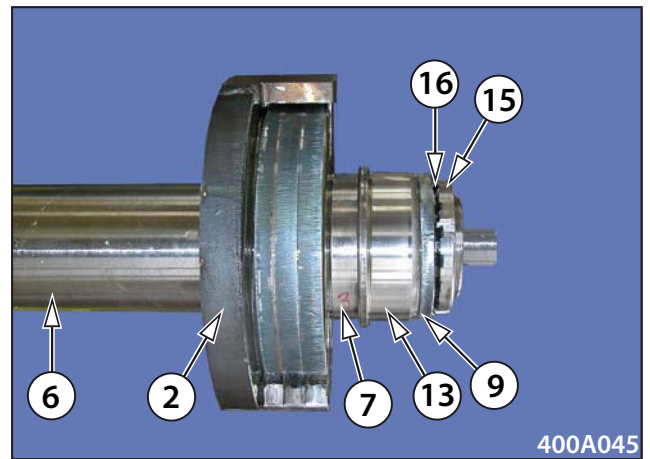

RH side

Release locking sheet 16.

Use fixture No. 5 to remove KM nut 15.

Use puller to pull down inner ring for bearing 13 and ring 9.

Take off rings 7.

Note

Vibrator, i.e. shaft 6 complete with eccentrics 1, 2, is one-piece unit.

When reinstalling cover assembly (drum is erected – aux. transmission for drive 11 down) ram the vibrator into the bearing in the cover 2, install cover 3 incl. bearing 13, screw lifting lug into the thread and pull the vibrator to check axial clearance of 3 mm.

Remove RH side – drive of travel

Fasten the clamp (fixture No. 3) of 2000 kg (4410 lb) loading capacity. Hang onto the crane, and erect drum with its LH side onto the ground.

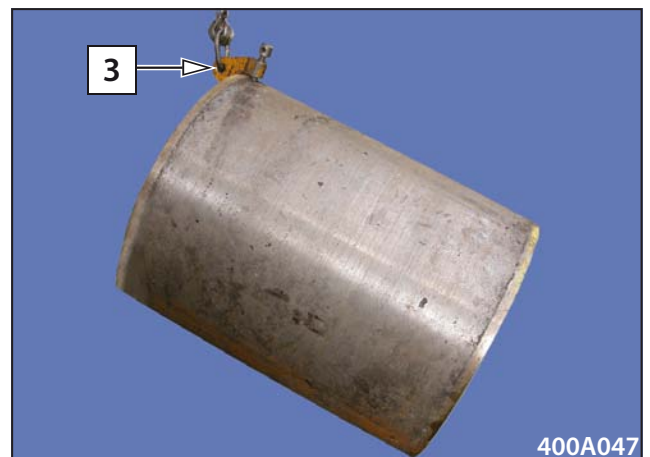
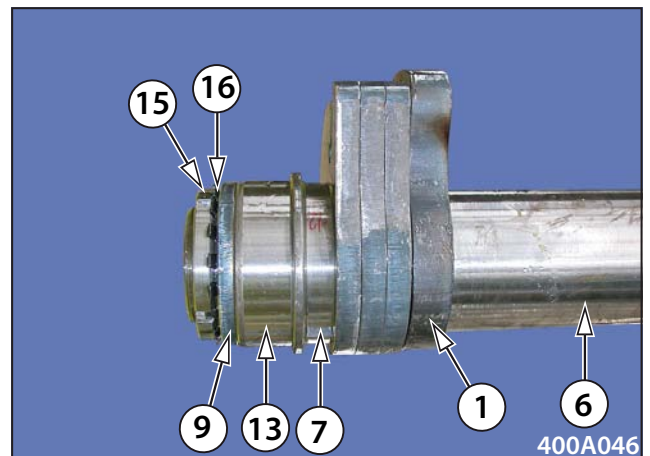

Remove screws 19 used to fix cover 6.

Note

When reinstalling, please clean contact surfaces. We recommend packing rings to be replaced. Check position of cover 6 against holes for screws 19. Use loctite 262 to cement screws 19, tighten with 48Nm torque.

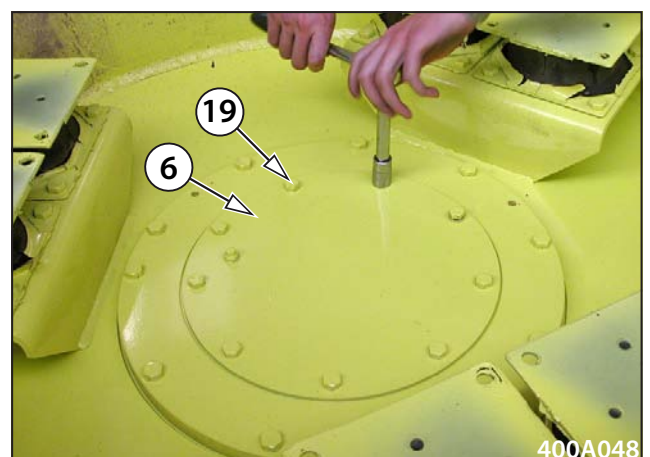

Disconnect cabin connector.



Mark and remove cabin earth connection.



Remove accelerator control cable.



Note

When reinstalling, please position the hole against the gap on the slewing ring. Fill bearing with grease via four lubricating points.

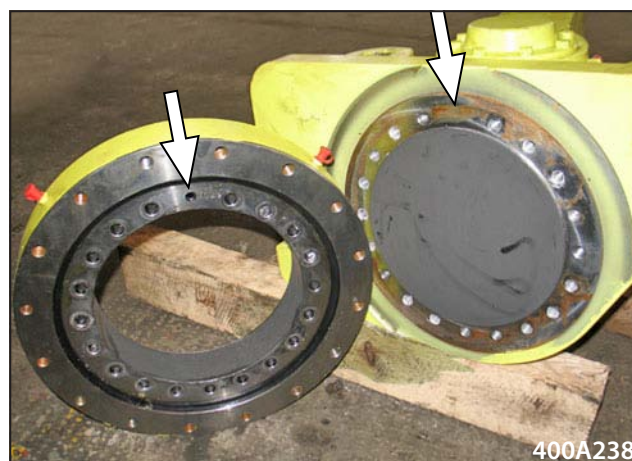

5.3. Remove steering joint bearings

Remove cover 10.

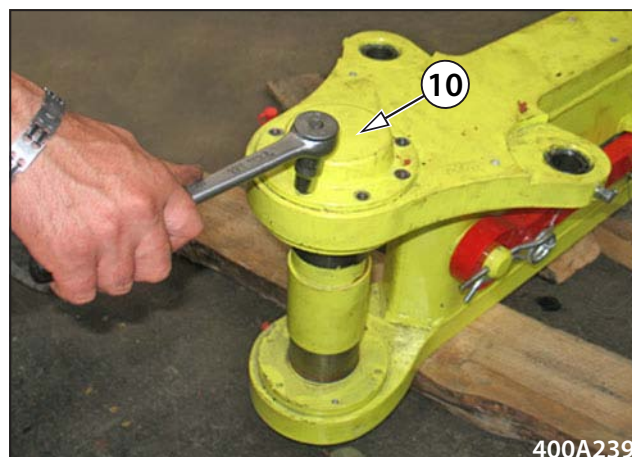

Unlock KM nut 35.



CLICK HERE TO **DOWNLOAD** THE COMPLETE MANUAL

- Thank you very much for reading the preview of the manual.
- You can download the complete manual from: www.heydownloads.com by clicking the link below



- Please note: If there is no response to CLICKING the link, please download this PDF first and then click on it.

CLICK HERE TO **DOWNLOAD** THE COMPLETE MANUAL

7.1. Remove hydraulic cylinders for steering and CRAB

Remove packing pieces 19.

- Rear one

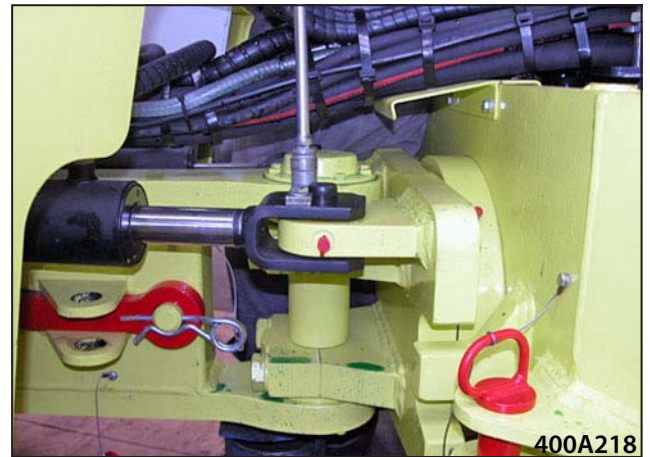

- Front one



Press out pins for hydraulic cylinder eyes. Take out hydraulic cylinder for steering from the brackets.

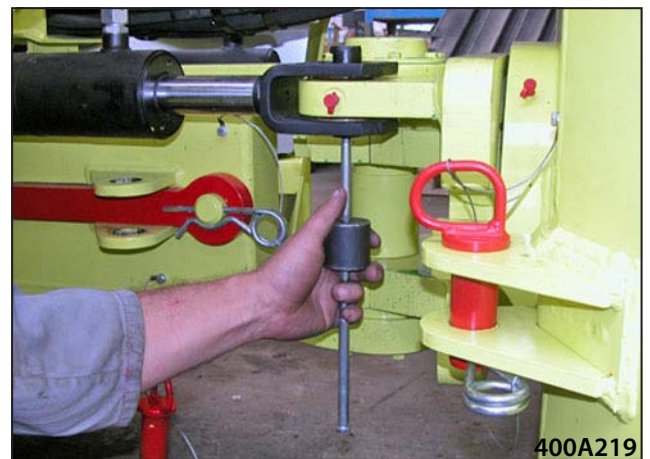

Mark and remove hydraulics hose pipe connection.

Proceed in the same way with CRAB hydraulic cylinder.

Note

Removal is required only for hydraulic cylinders that require to be repaired or replaced.

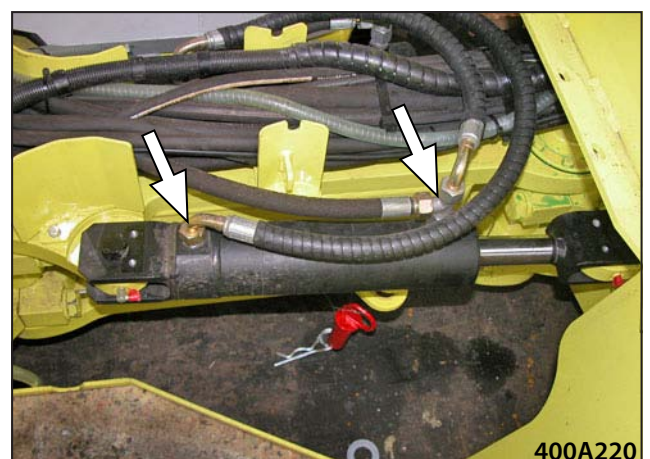

Use lever 1 to slip out carefully hydraulic cylinder from the pin.
Remove hose pipe from hydraulic cylinder.

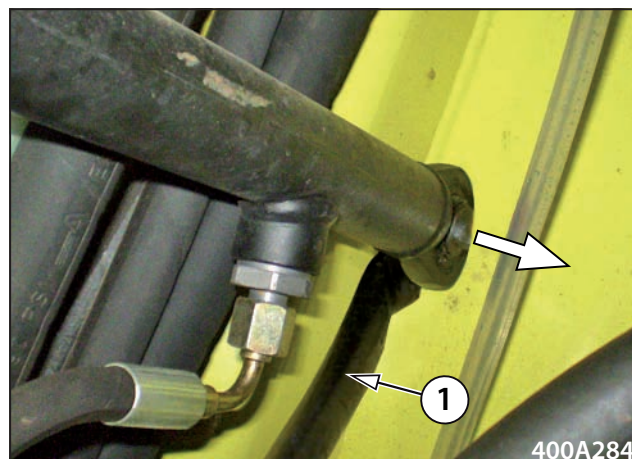

Remove flange for turbo charger.

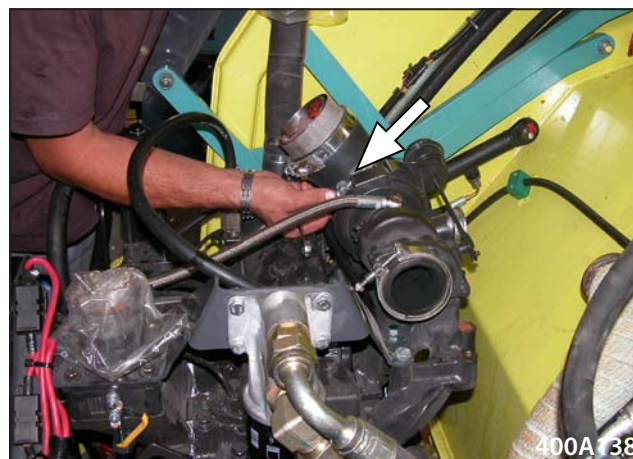

Disconnect wiring for contactors of glowing and starter motor.

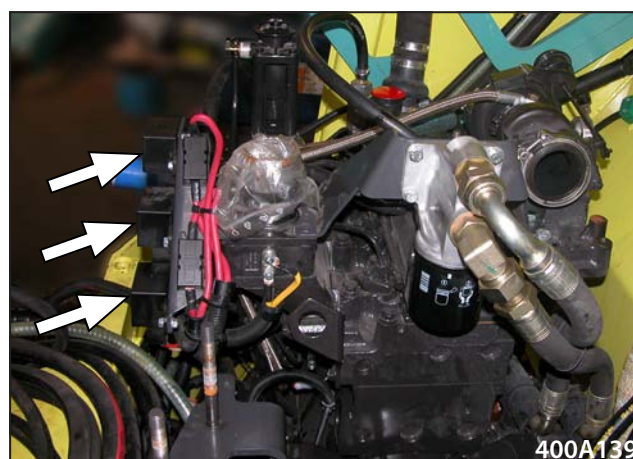

Remove oil filter holder, lift it off.

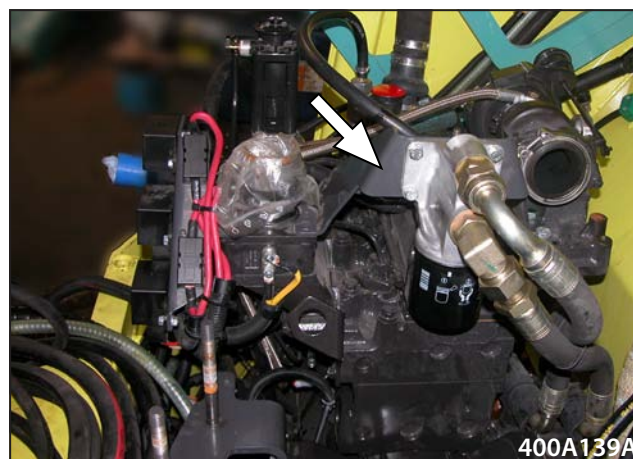

11. Cabin

11.4. Idle and parking brake positions sensor

Replace idle (neutral) and parking brake positions sensor 23. When replaced, please adjust X gap to 1,5 mm between rocker arm 7 and switch 23.

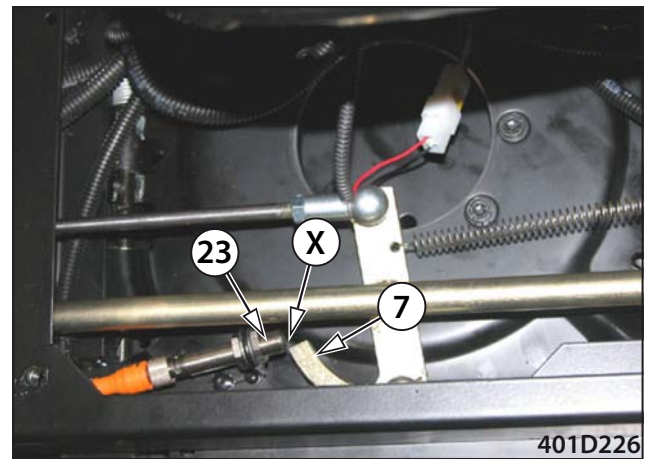

11.5. LH control panel, backing horn sensor

Remove LH panel cover.



Replace backing horn switch 23, sprinkling cycling device potentiometer 47, travel control position sensor 22, and STOP switch 43.

After you replace backing horn switch 23, please adjust the gap to 1,5 mm between arm 5 and switch 23.

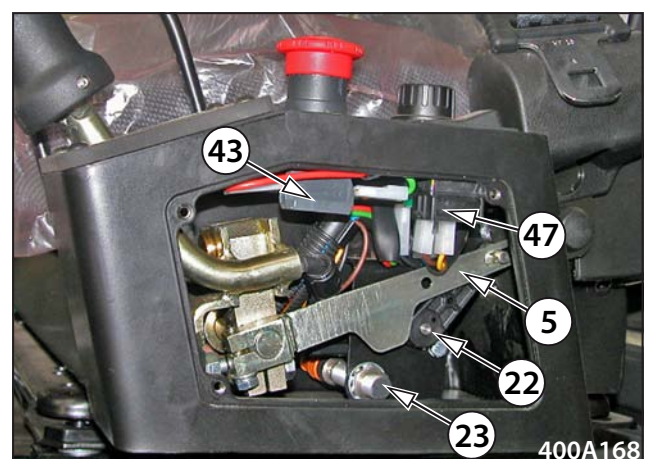

12. Wiring

View B

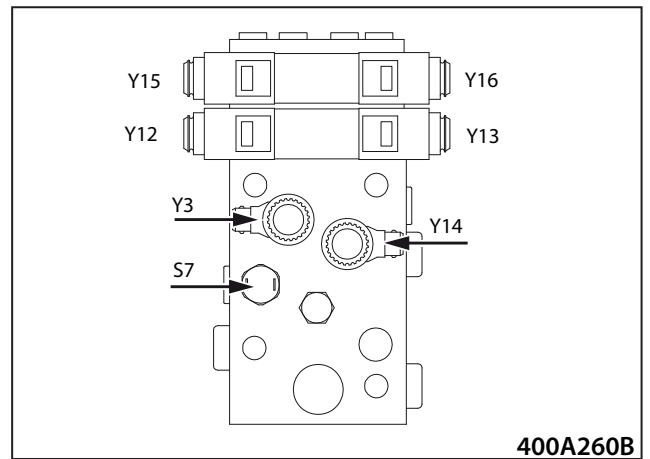

View C

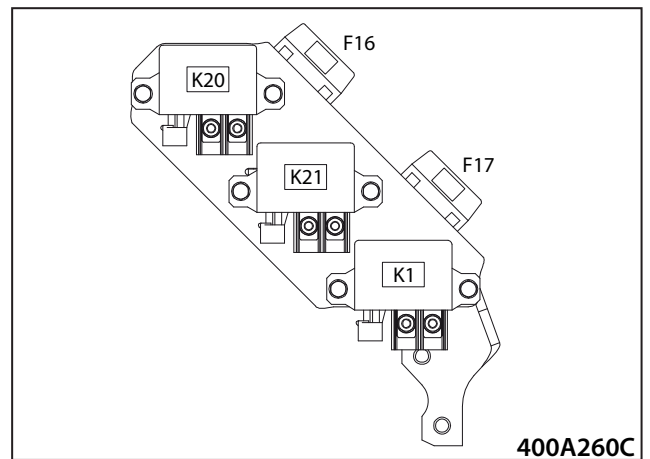

View D

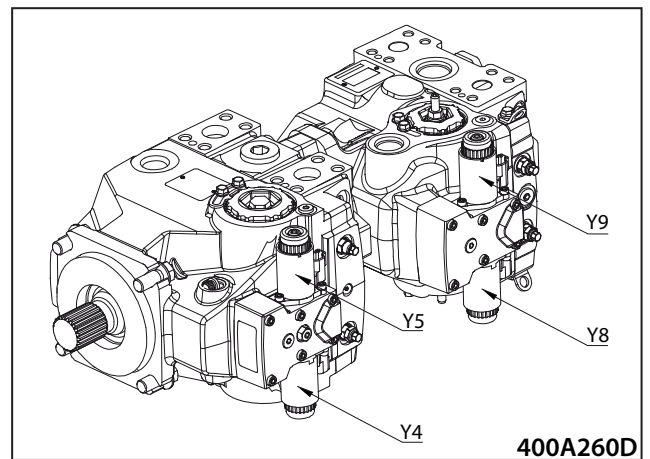

View E

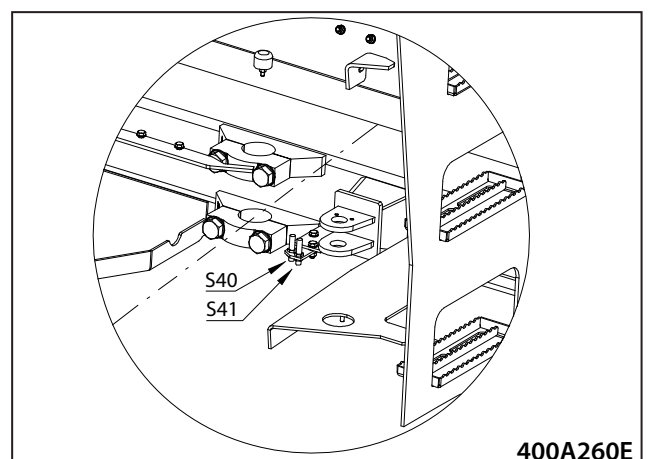

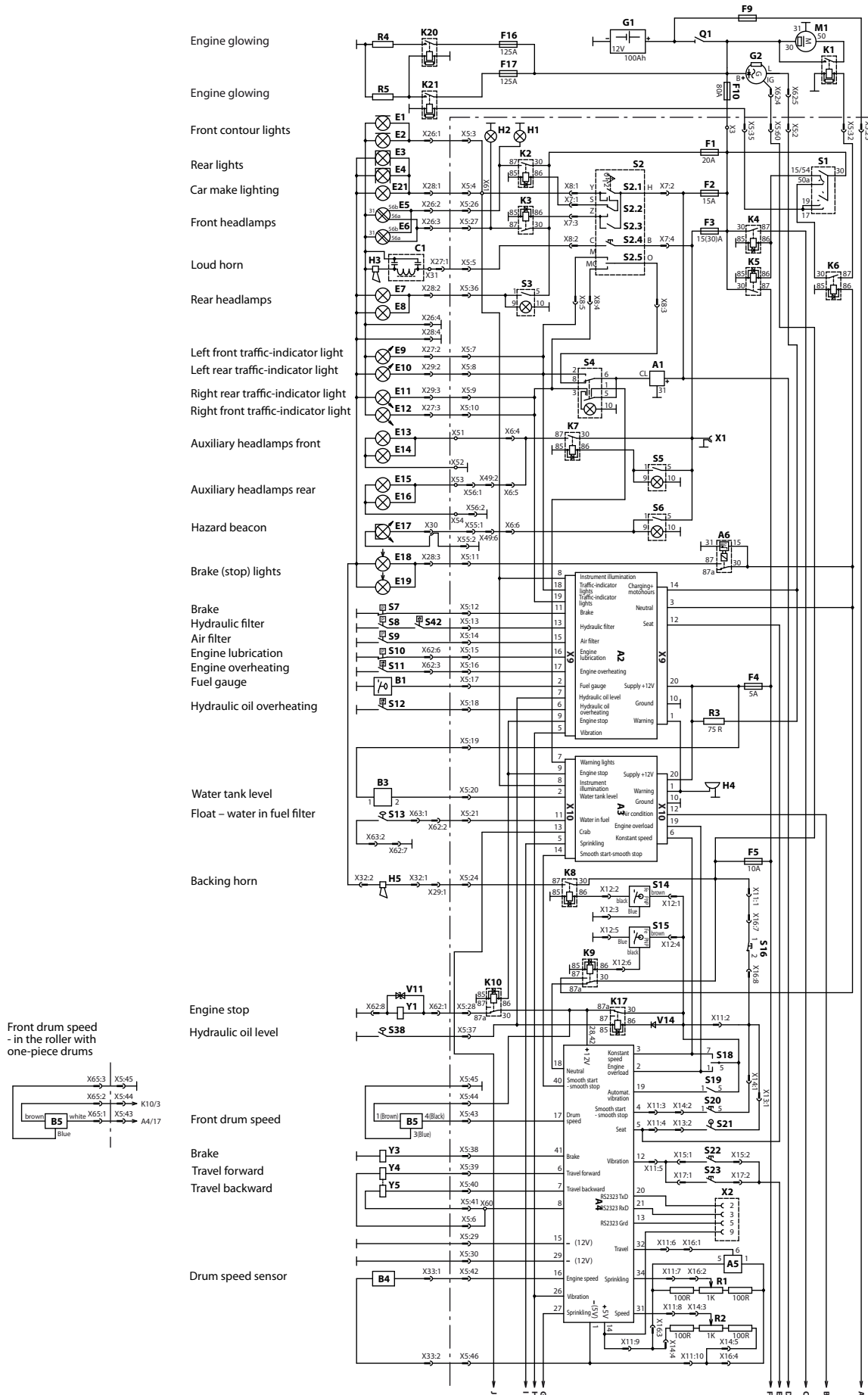

CLICK HERE TO **DOWNLOAD** THE COMPLETE MANUAL

- Thank you very much for reading the preview of the manual.
- You can download the complete manual from: www.heydownloads.com by clicking the link below



- Please note: If there is no response to CLICKING the link, please download this PDF first and then click on it.

CLICK HERE TO **DOWNLOAD** THE COMPLETE MANUAL