

ARX 90

TANDEM ROLLER
DEUTZ Tier 3

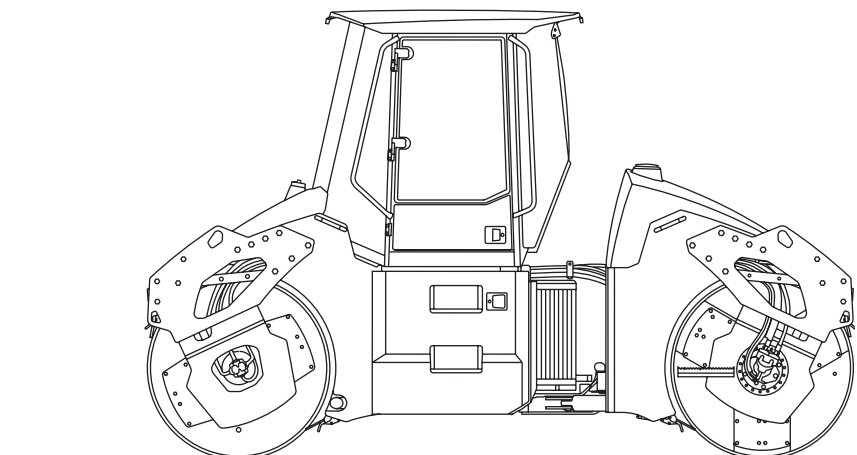

WORKSHOP MANUAL

EDITION 10/2018 EN
From Serial No. 4122059

AMMANN

CLICK HERE TO **DOWNLOAD** THE COMPLETE MANUAL

- Thank you very much for reading the preview of the manual.
- You can download the complete manual from: www.heydownloads.com by clicking the link below



- Please note: If there is no response to CLICKING the link, please download this PDF first and then click on it.

CLICK HERE TO **DOWNLOAD** THE COMPLETE MANUAL

2. Safety Precautions and Instructions

Legend:

- 1 - Front frame
- 2 - Rear frame
- 3 - Front drum
- 4 - Rear drum
- 5 - Engine
- 6 - Hydrogenerator for travel (roll)
- 7 - Hydrogenerator for vibration of front drum
- 8 - Hydrogenerator for vibration of rear drum
- 9 - Travel hydraulic motor
- 10 - Vibration hydraulic motor
- 11 - Steering joint
- 12 - Hydraulics tank
- 13 - Fuel tank
- 14 - Sprinkling tank
- 15 - Cabin with integrated frame ROPS
- 16 - Driver's control stand
- 17 - Batteries
- 18 - Combined cooler
- 19 - Air filter
- 20 - Exhaust pipe
- 21 - Sprinkling jets
- 22 - Drum scrapers

Axle		ARX 90	ARX 90 HF	ARX 90 K
Maximum tyre pressure	kPa	-	-	180
Number of tyres	-	-	-	4
Number of rear wheels	-	-	-	4
Size of tyres	-	-	-	11,00x20" 16PR
Type of tyres	-	-	-	COMPACTOR
Type of tyres	-	-	-	Tube Type
Brakes				
Operating	-	Hydrostatic	Hydrostatic	Hydrostatic
Parking	-	Mechanical multiple-disc	Mechanical multiple-disc	Mechanical multiple-disc
Emergency	-	Mechanical multiple-disc	Mechanical multiple-disc	Mechanical multiple-disc
Vibration				
Frequency I	Hz (VPM)	42 (2520)	46 (2760)	42 (2520)
Frequency II	Hz (VPM)	54 (3240)	67 (4020)	54 (3240)
Oscillation frequency	Hz (VPM)	40 (2400)	40 (2400)	-
Amplitude I	mm (in)	0,7 (0,028)	0,62 (0,024)	0,7 (0,028)
Amplitude II	mm (in)	0,34 (0,013)	0,23 (0,009)	0,34 (0,013)
Oscillation amplitude	mm (in)	40 (2400)	40 (2400)	-
Centrifugal force I	kN	84	97	84
Centrifugal force II	kN	68	70	68
Type of drive	-	Hydrostatic	Hydrostatic	Hydrostatic
Watering				
Type of watering	-	Pressure	Pressure	Pressure
Number of pumps	-	2	2	2
Number of filtrations	-	3	3	3
Fluid capacities				
Fuel	l (gal US)	220 (58,1)	220 (58,1)	220 (58,1)
Water for drum watering	l (gal US)	840 (221,9)	840 (221,9)	840 (221,9)
Spraying emulsion	l (gal US)	-	-	28 (7,4)
Engine (oil filling)	l (gal US)	9 (2,4)	9 (2,4)	9 (2,4)
Cooling system	l (gal US)	23 (6,1)	23 (6,1)	23 (6,1)
Hydraulic system	l (gal US)	60 (15,9)	60 (15,9)	60 (15,9)
Vibrating drum front (oil filling)	l (gal US)	7,5 (2)	7,5 (2)	7,5 (2)
Vibrating drum rear (oil filling)	l (gal US)	7,5 (2)	7,5 (2)	7,5 (2)
Drum cooling liquid	l (gal US)	2x60 (2x15,85)	2x60 (2x15,85)	60 (15,85)
Drum drive reducer	l (gal US)	2x2 (2x0,53)	2x2 (2x0,53)	2 (0,5)
Axle drive reducer	l (gal US)	-	-	2x2 (2x0,53)

6. Lubrication and Maintenance Chart

7.2. Technical data of the manufacturer

General technical data		
Engine type	Dimension	TCD 3.6 L4
Working principle		Four-stroke diesel engine
Charging		Turbocharger with charge air cooling
Type of cooling		water-cooled
Cylinder arrangement		in series
No. of cylinders		4
Bore/stroke	mm	98/120
Total displacement	cm ³	3621
Combustion process		Direct injection
Injection system		Common Rail
Exhaust gas recirculation		externally cooled
Exhaust gas aftertreatment		Diesel oxidation catalytic converter DOC
Valves per cylinder		2
Firing order of the engine		1-3-4-2
Direction of rotation looking onto the flywheel		left
Engine power rating according to ISO 3046	kW	see engine rating plate
Speed (nominal revolutions)	min ⁻¹	see engine rating plate
Injection timing	°BTDC	see engine rating plate
Coolant volume (only engine content without cooler / hoses and pipes) Industrial engines/Agricultural technology	L	4,6/4,6
Permissible continuous coolant temperature	°C	max. 110
Temperature difference between coolant inlet/outlet	°C	8
Start of thermostat opening	°C	88
Thermostat fully open	°C	95
Lubricating oil change volume (with filter)	l	8*
Lube oil temperature in the lube oil tray, maximum	°C	125
Lubricating oil pressure minimum (low idle, engine warm)	kPa/bar	80/0,8
Permissible maximum combustion air temperature after charge air cooler	°C	50
V-belt tension V-belts AVX (width: 13 mm)	N	Pre-tensioning/Re-tensioning 650±50/400±50
V-rib belt tensioning		Automatic tensioning spring-loaded clamping roller
Weight without cooling system according to DIN 70020-A	kg	350

*specified lubricating oil filling volumes apply for standard versions. In engines which deviate from the standard, for example different lubricating oil pans/dipstick variants and/or special inclined versions, the lubricating oil volume may vary. The lubricating oil dipstick mark is always decisive.

Remove the clips (001-126-22). Remove the hose (001-126-28).

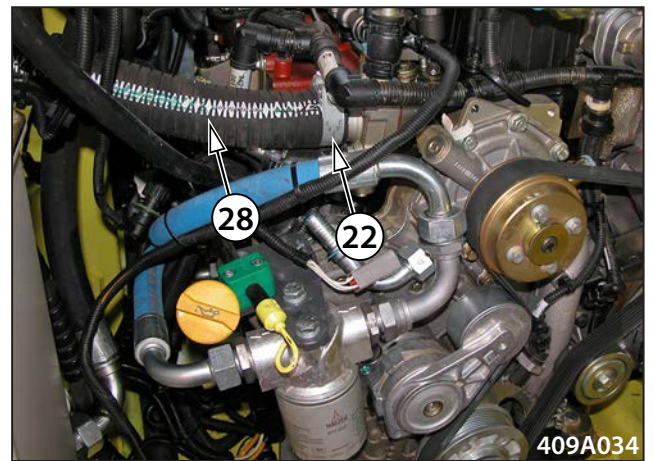

Remove the hose (001-106-44).

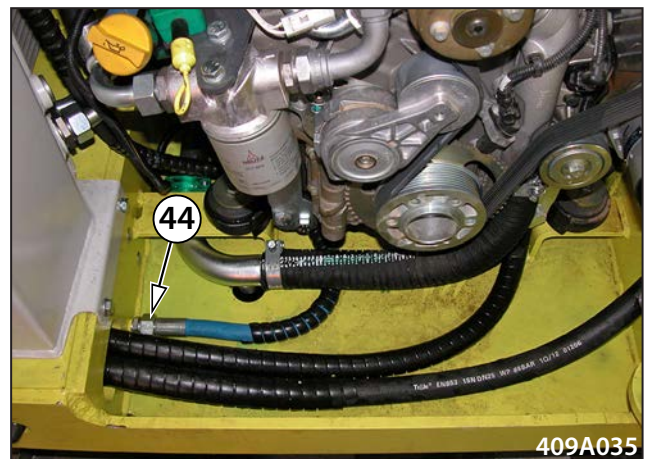

Remove the clip (001-126-22). Remove the hose (001-126-28).

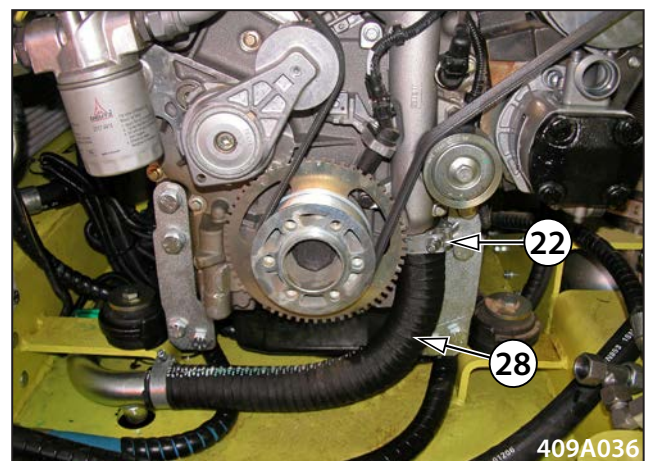

Disconnect the connector from the engine.

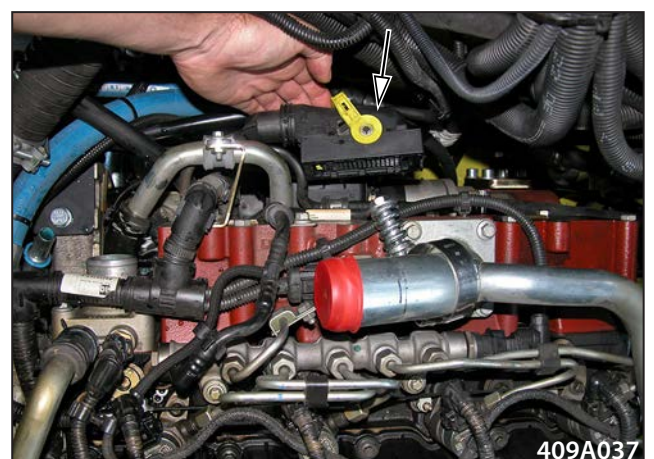

005-364

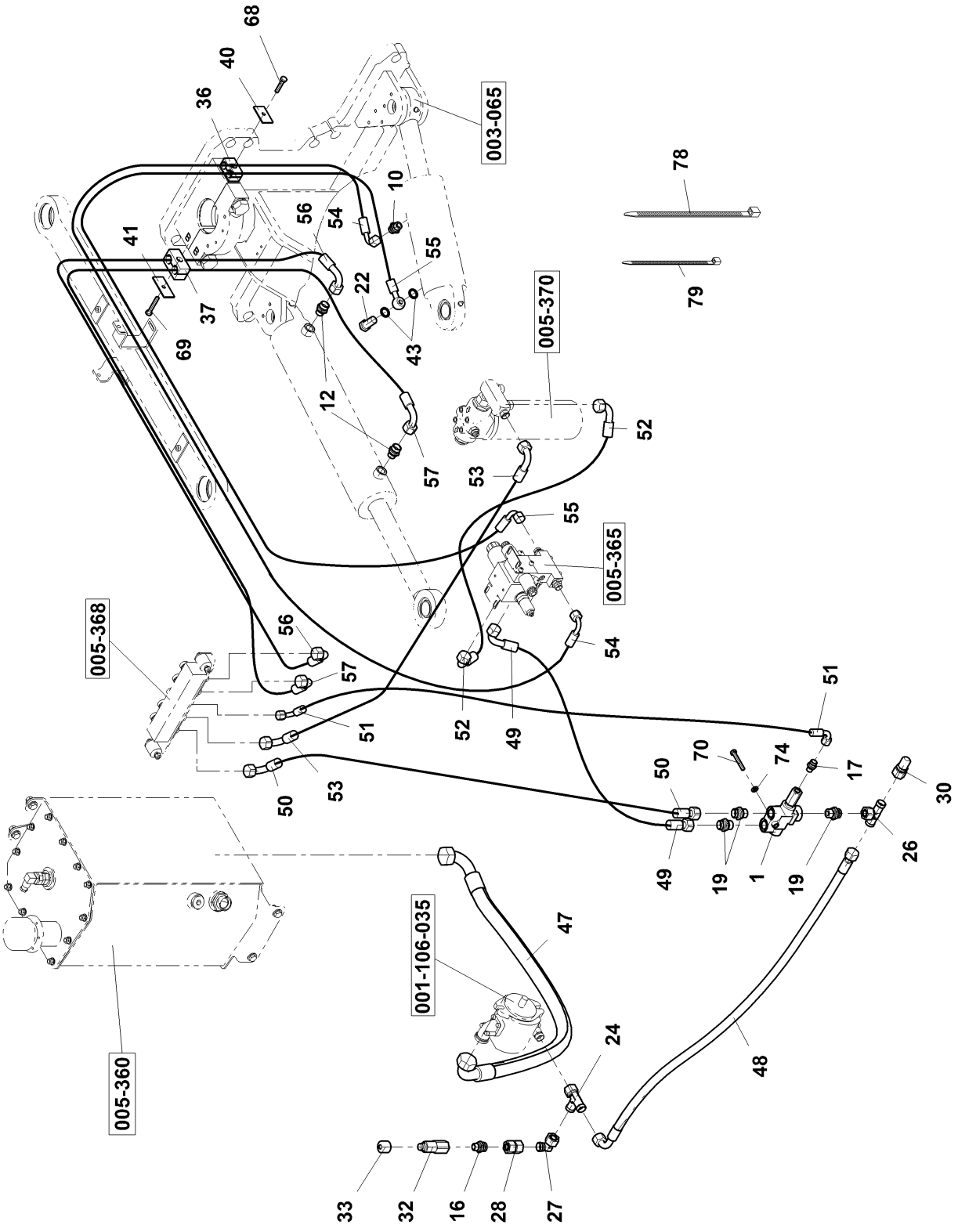

Release the cover of the hydraulic motor.

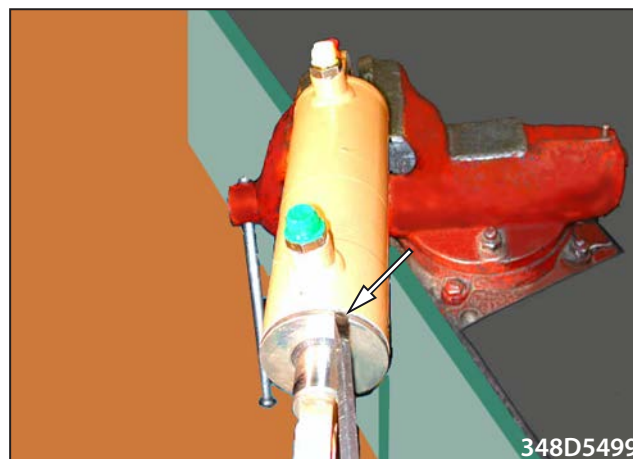

Remove the cover of the hydraulic motor using the hook wrench.



Take out.

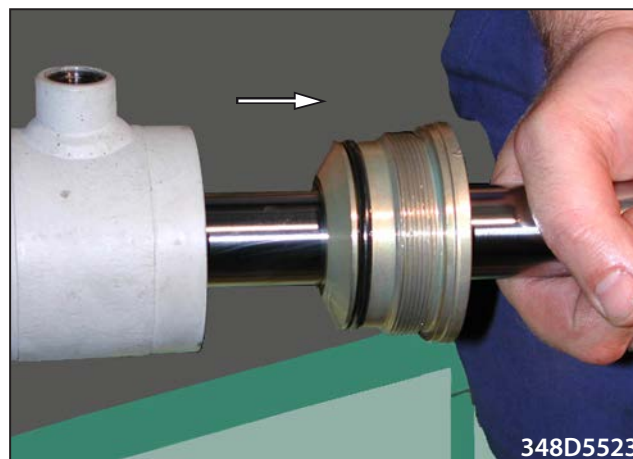

Take out the piston of the hydraulic motor.

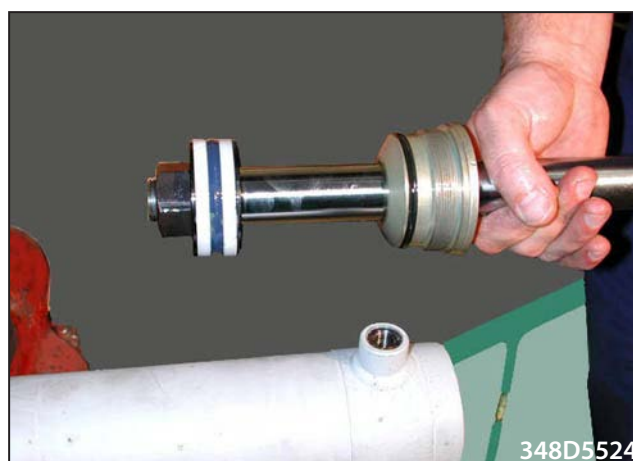

Disconnect the hydraulic hose.



Disconnect the hydraulic hose.



Remove the piping. When reassembling, apply the sealing compound Lukopren S9780 on contact surfaces.

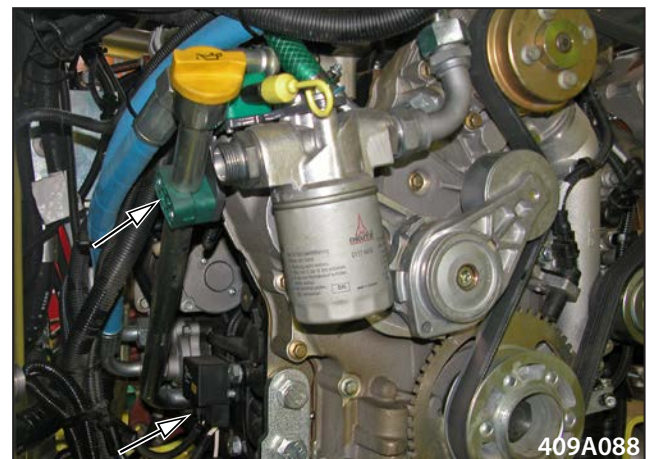

003-065-002

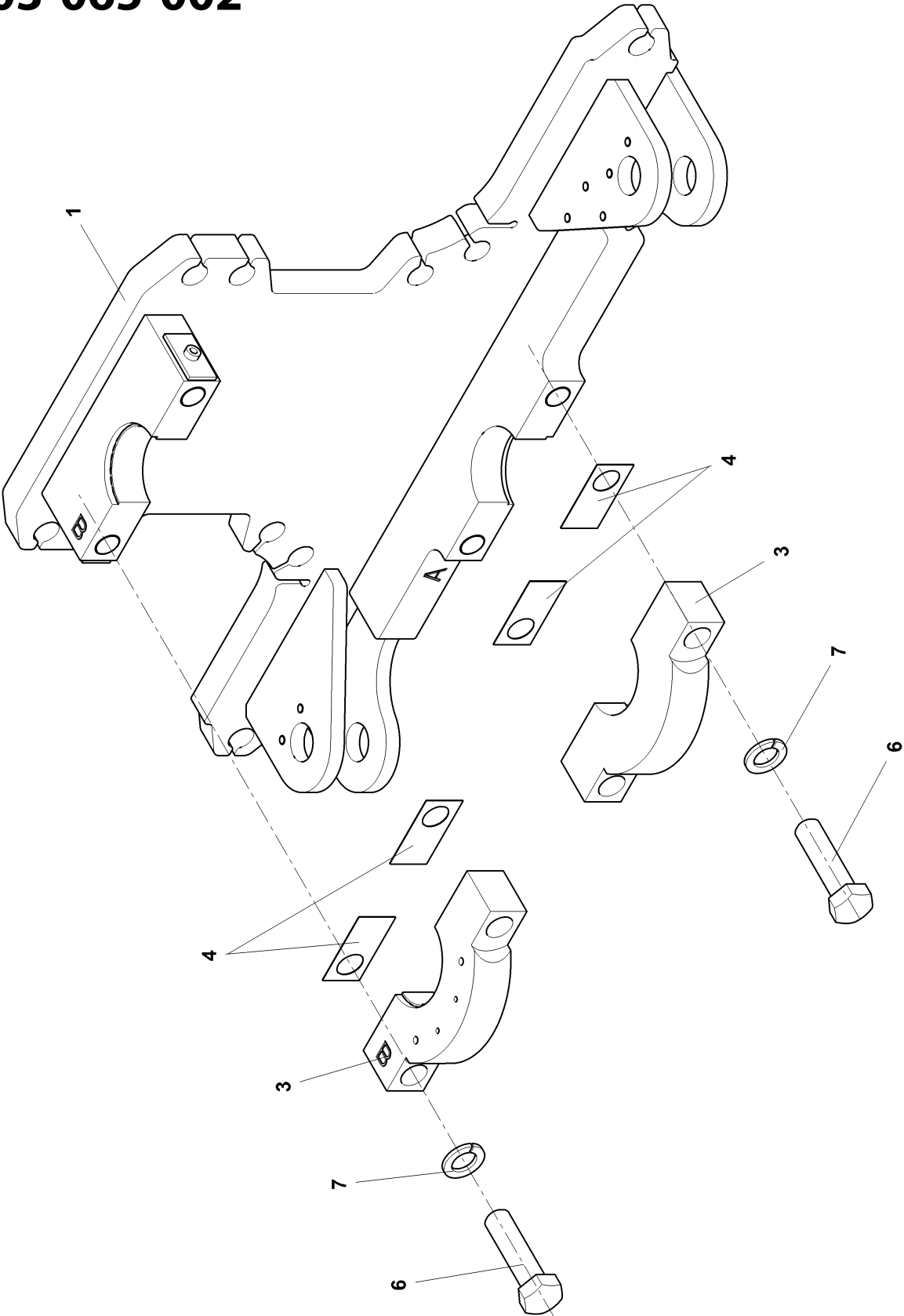

Press out the bush (003-065-12) from the bearing (003-065-3) and the cover (003-065-19).

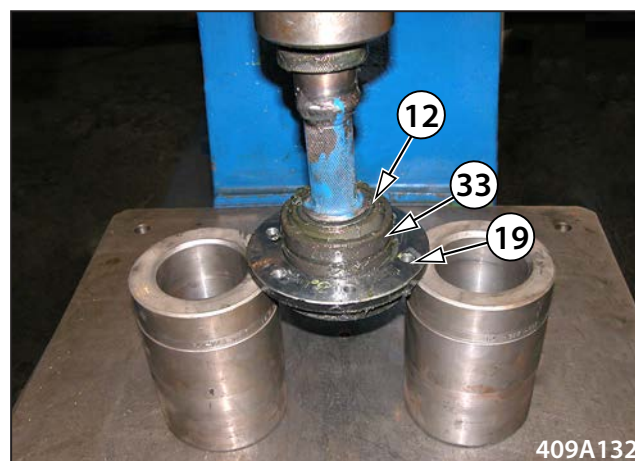

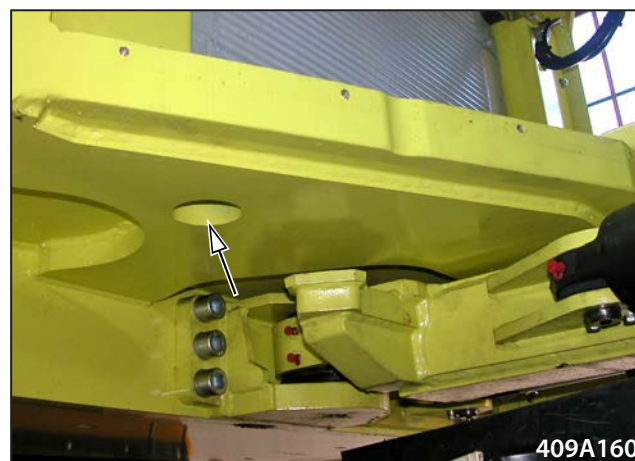

Move the cooler.



Remove the screws (003-065-49) of the fishplate (003-065-20).

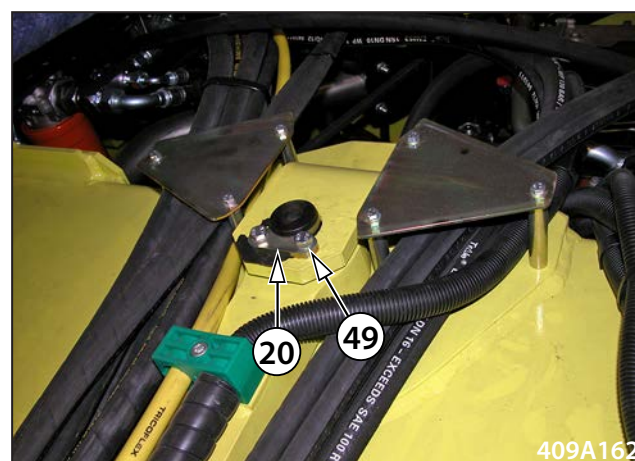

Remove the pin (003-065-8).



002-031

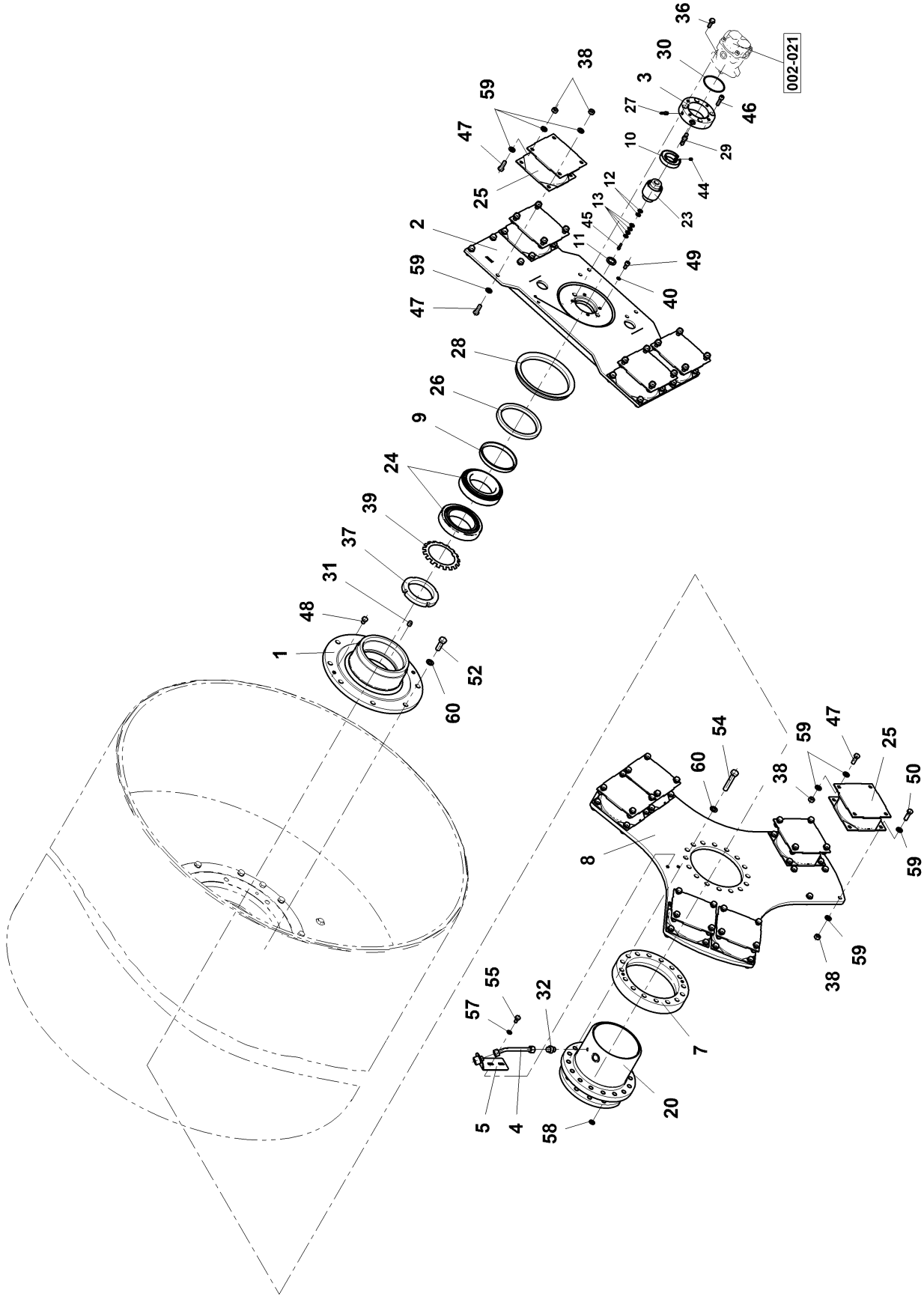

Remove the hydraulic hoses from the cube.

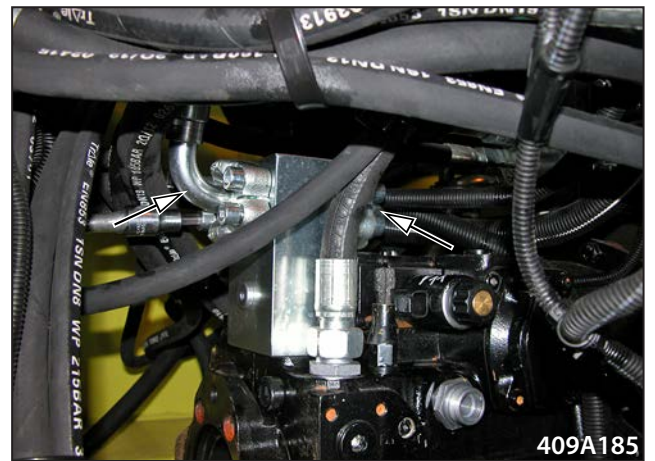

Hang the pump (001-290-1) on the lifting device. Pump weight 110 kg (243 lb). Remove the screws (001-290-6).

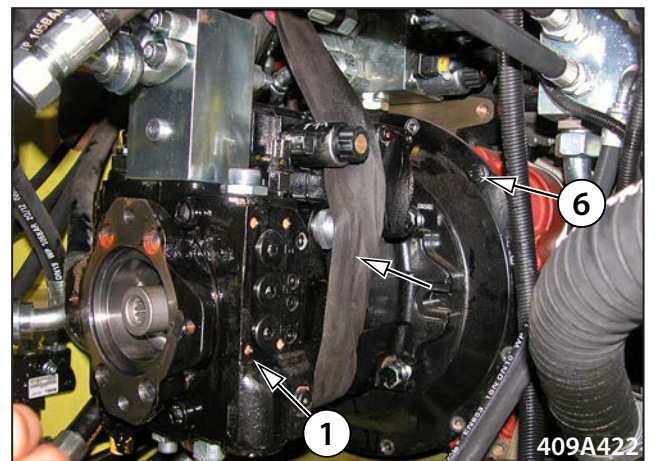

Take out the pump.

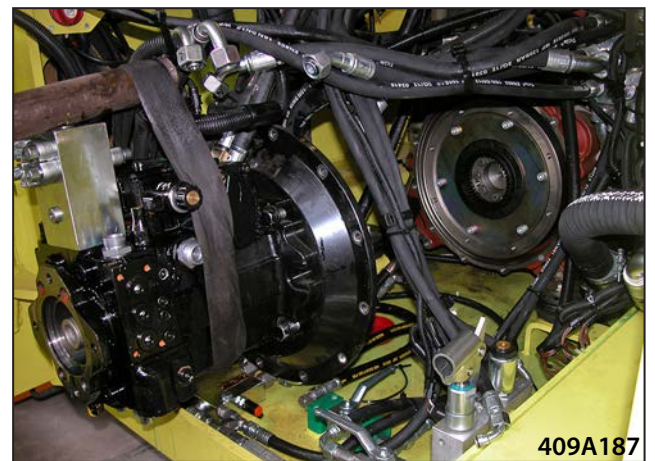

Put the vessel for capturing any leaking fluids under the vibration hydraulic motor.



Remove the hydraulic hoses (005-301-33), (005-301-34), (005-301-35), (005-301-36). Mount the plugs.

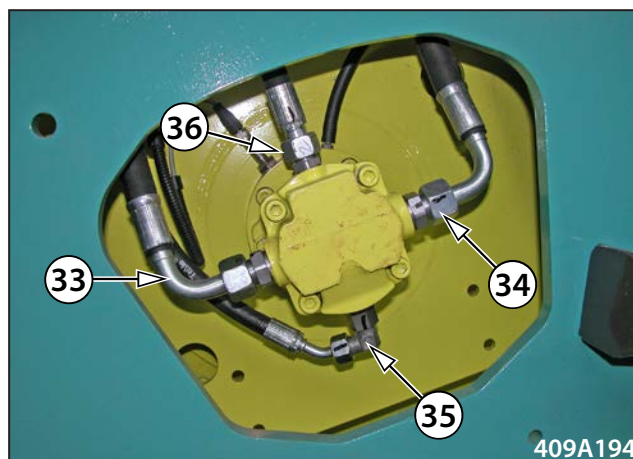

Remove necks (005-301-14), (005-301-15), (005-301-16).

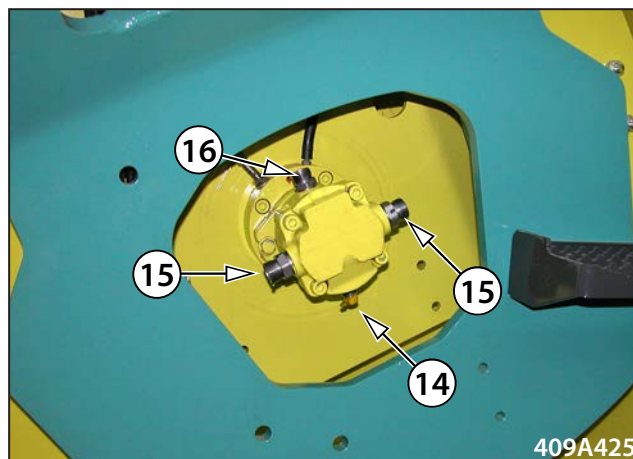

Remove the screws (002-031-36).

Note

Nuts (002-031-36) tighten to torque of 67 Nm (49 lbft) during re-assembly. Secure the screws using adhesive Loctite 262.

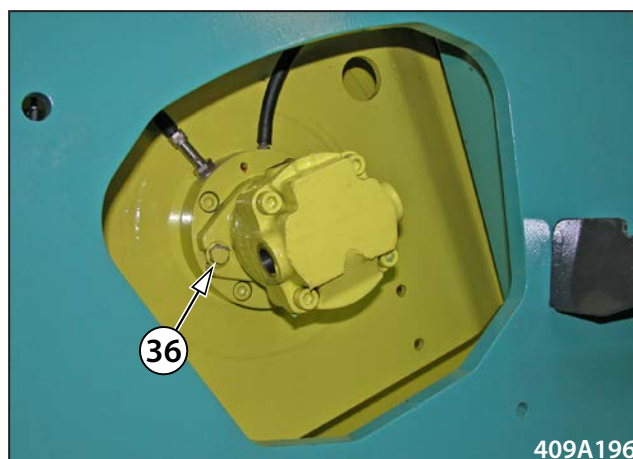

Take out the pump.



Check the O-ring and replaced it, if damaged.

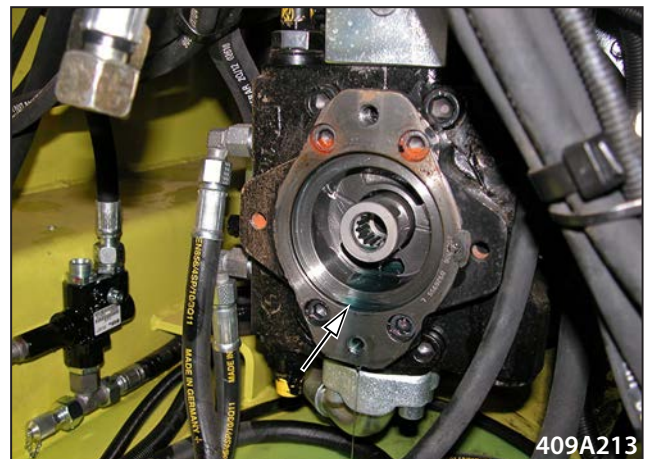

Remove the necks and measuring points from pump and mount them on a new one.

After restoring the machine to its original state, refill the hydraulic oil to the specified limit.

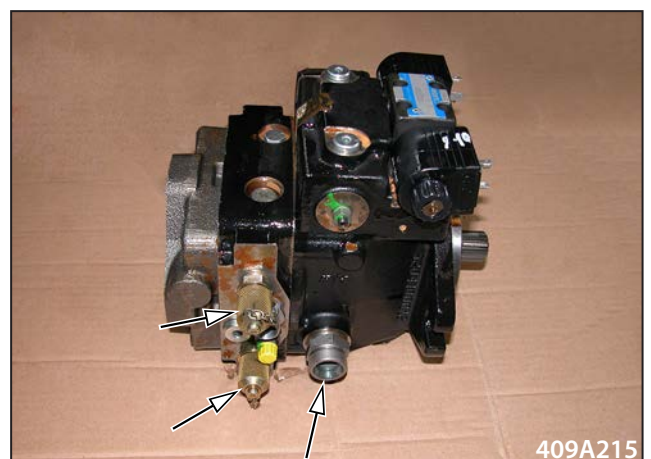
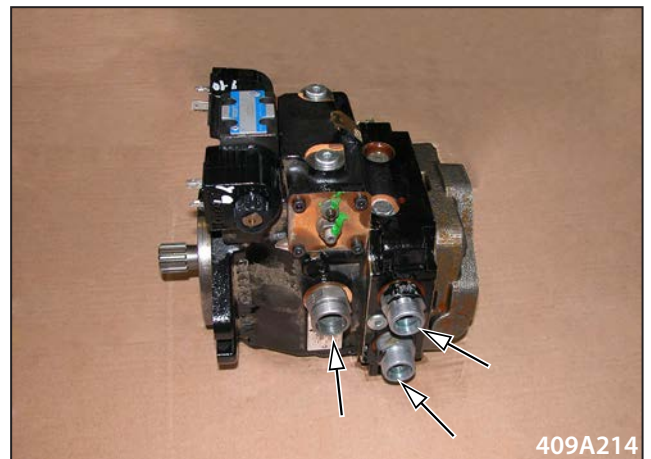

Lay the sidewall aside.



Roll the drum out and secure it against motion.

Apply the same procedure for removal of front drum.



CLICK HERE TO **DOWNLOAD** THE COMPLETE MANUAL

- Thank you very much for reading the preview of the manual.
- You can download the complete manual from: www.heydownloads.com by clicking the link below



- Please note: If there is no response to CLICKING the link, please download this PDF first and then click on it.

CLICK HERE TO **DOWNLOAD** THE COMPLETE MANUAL

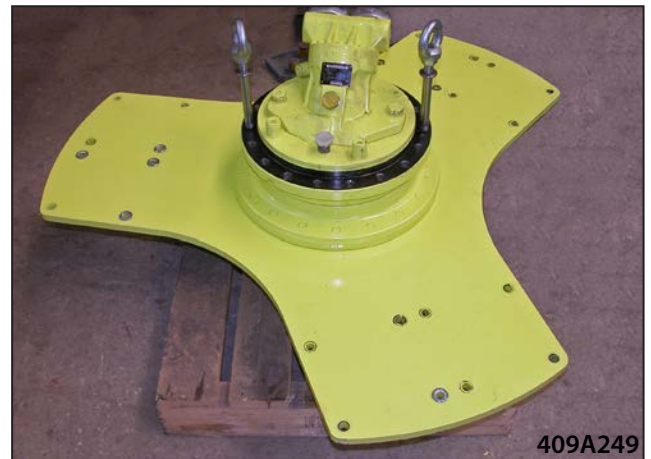

Remove the plugs (002-001-16) and screws (002-001-15).

Note

Secure the plugs (002-001-16) and screws (002-001-15) using adhesive 262.

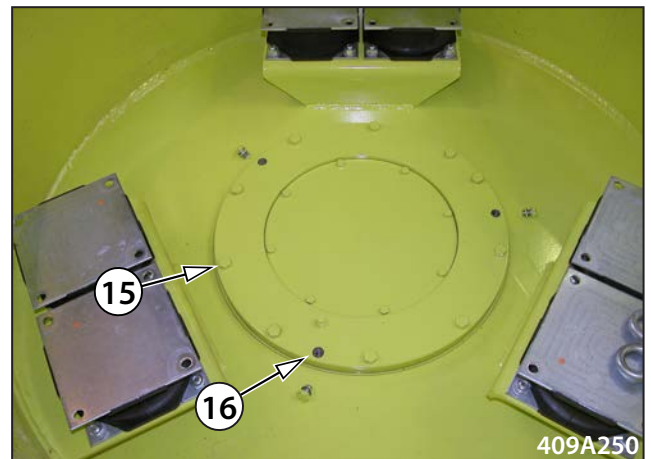

Fit the screws and push the cover away evenly (002-001-1).

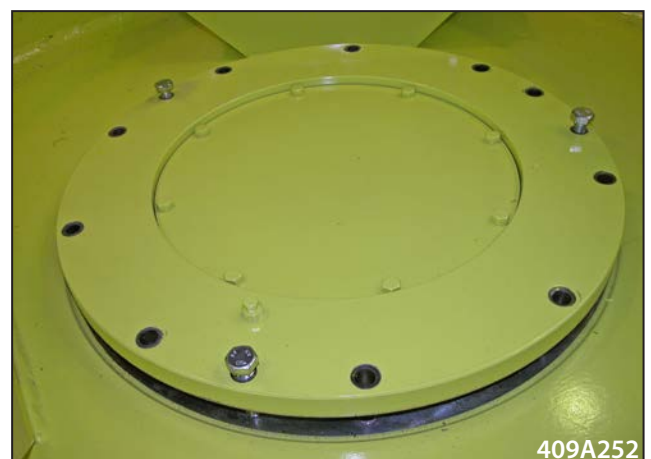
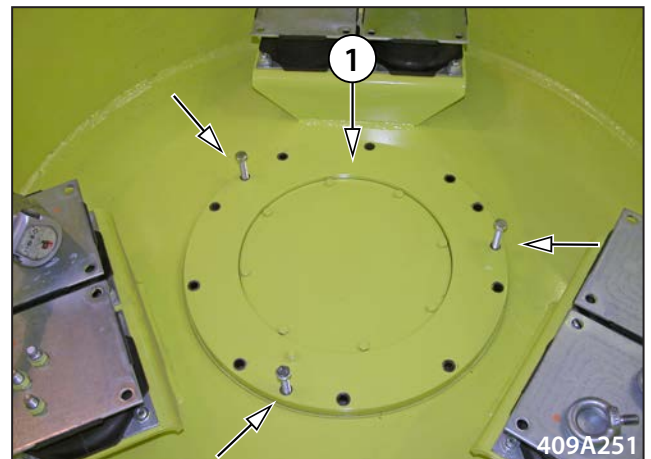

Note

Secure the screws (002-031-52) with the adhesive loctite 262.

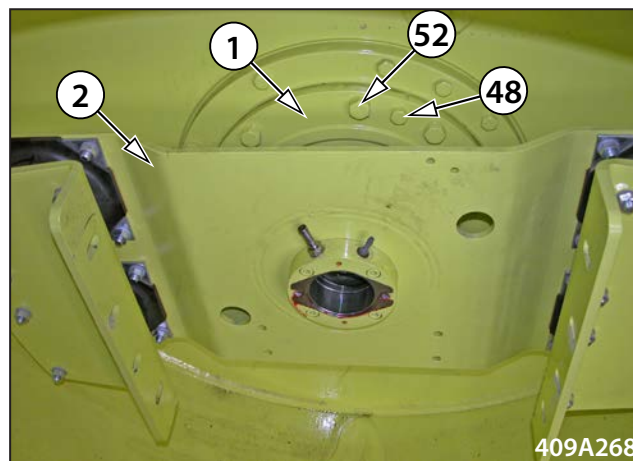

409A268

Fit the screws and force the flange away evenly (002-031-1).

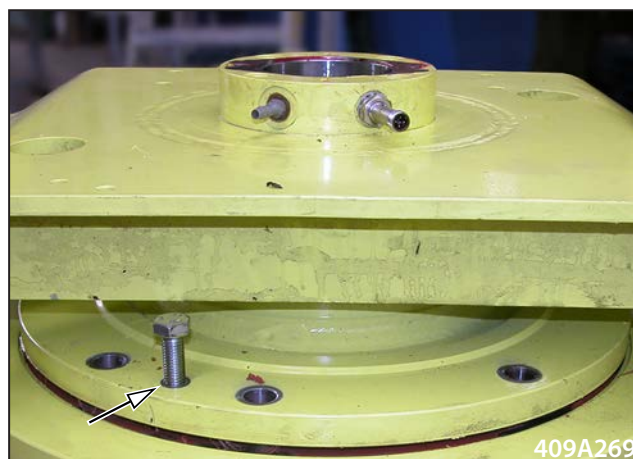

409A269

Remove it and lay it aside.

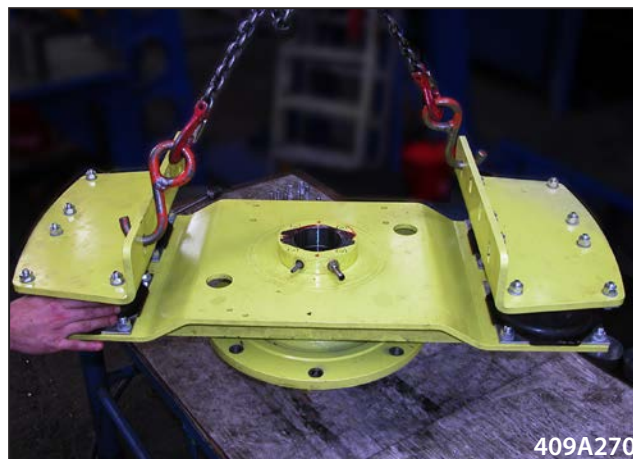

409A270

Mark the position of spacer (002-031-3). Remove the screws (002-031-46).

Remark

When mounting components on contact surfaces of the spacer (002-031-3), apply the sealing compound Lukopren N1522. The tightening torque of the screws (002-031-46) is 48 Nm (35 lbft). Secure the screws using adhesive Loctite 262.

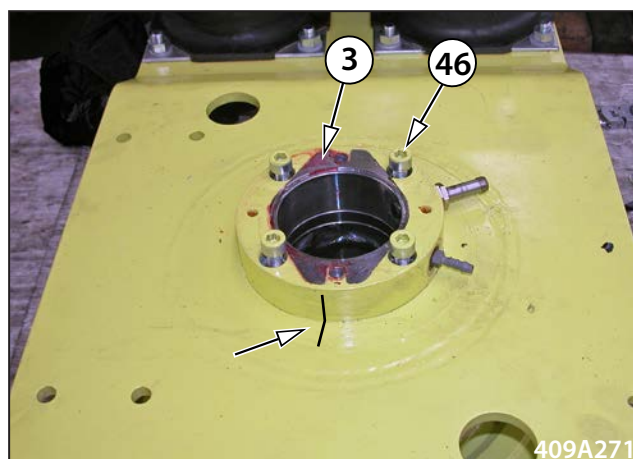

409A271

11. Cooling

Remove the hydraulic hose (005-370-40).



Remove the piping (001-126-28), (001-126-15).

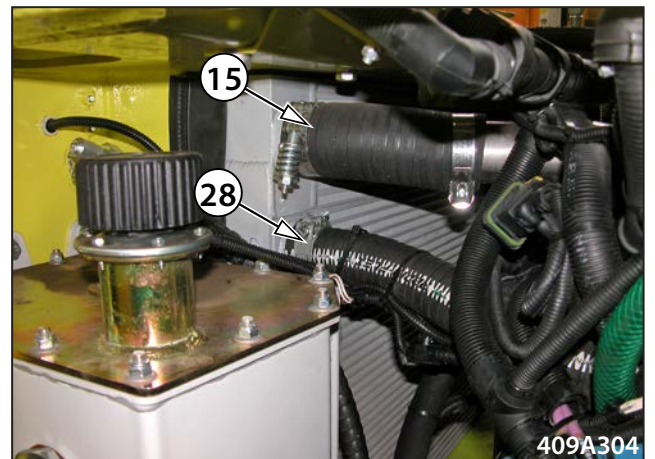

Remove the brake block. Take off.



004-160-002

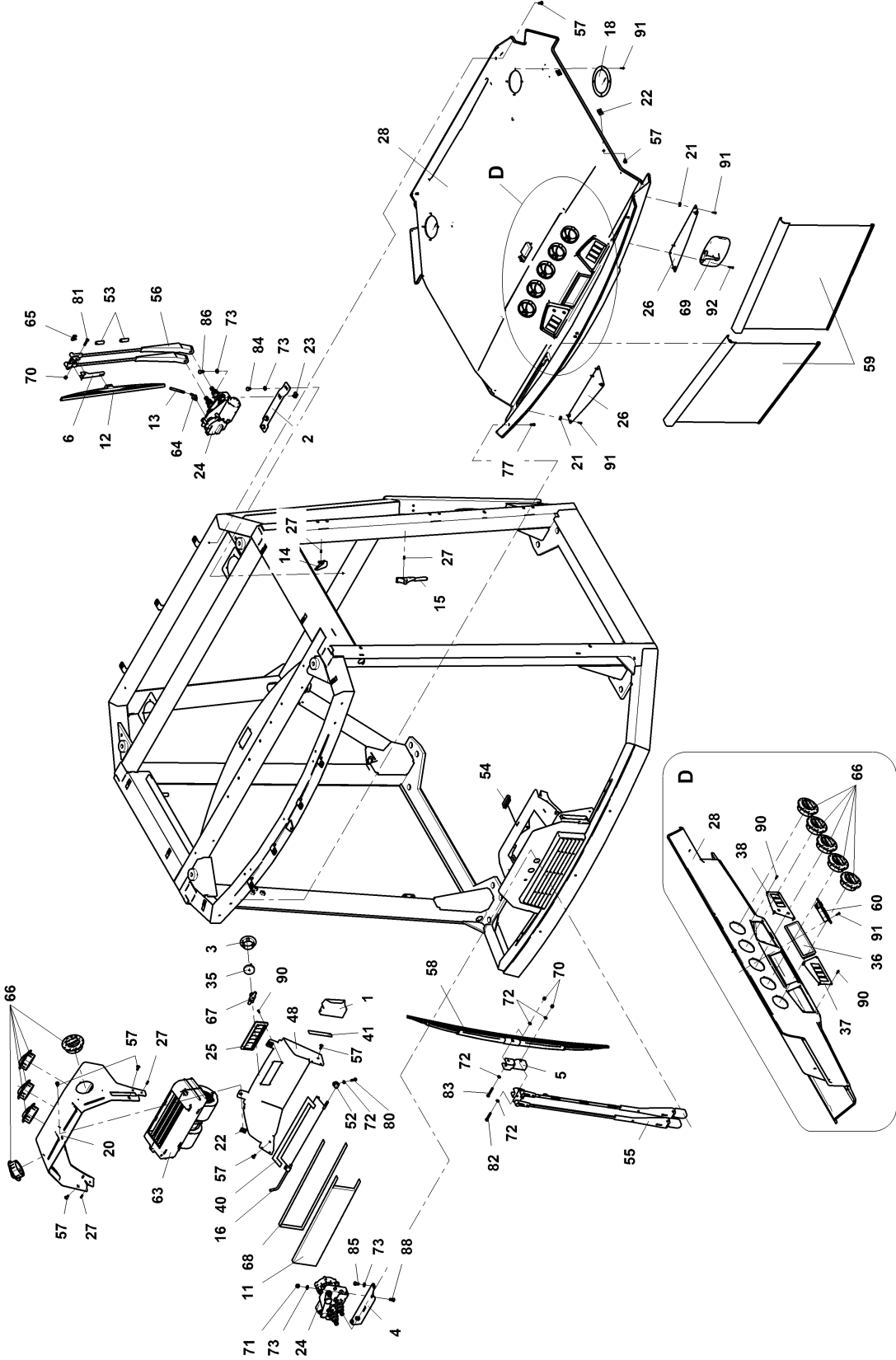

4-1235037B

Remove the bars on both sides.



Remove the cover.



Remove the heating hoses.

Remove the screws fixing the cab.

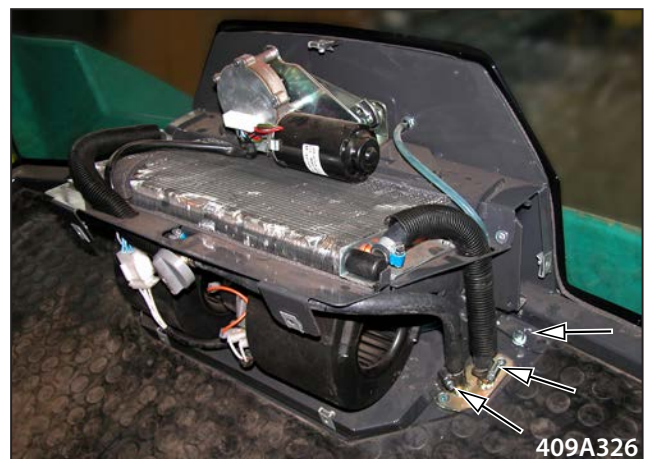

Remove the screws and mount the lifting lugs (4) Hang the cab on the crane of sufficient load capacity. Cab weight 540 kg (1190 lb).

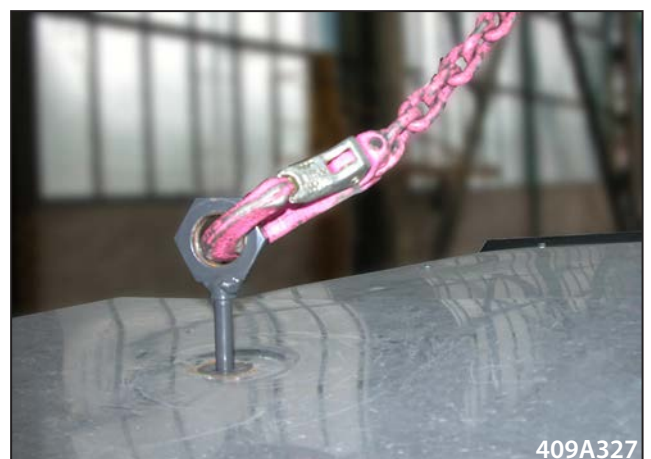

Disconnect the connector.

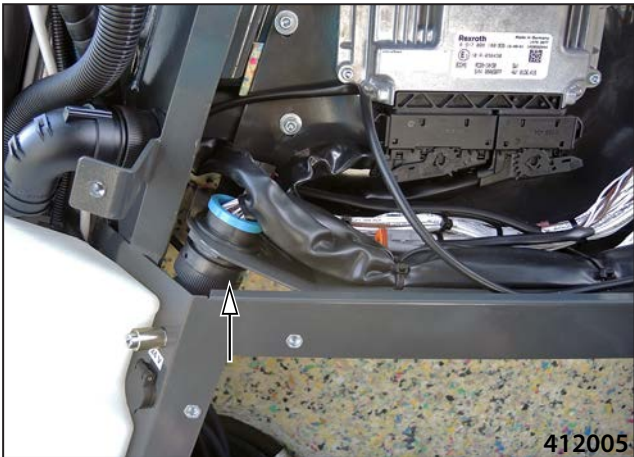

Disconnect the connector.



Disconnect the connector.



Remove the cover (004-150-10).



Complete the following tasks before disassembly:

12.4. Remove the machine cab

Drain the coolant.

Drained volume 23 l (6.1 gal US).

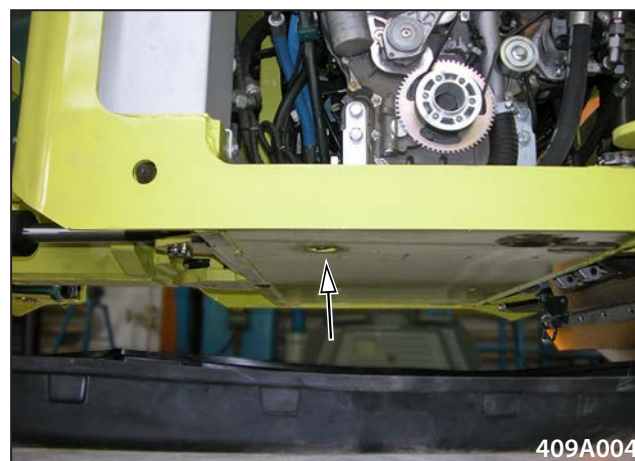

Remove the cover (004-151-045).



Disconnect the connector X11.

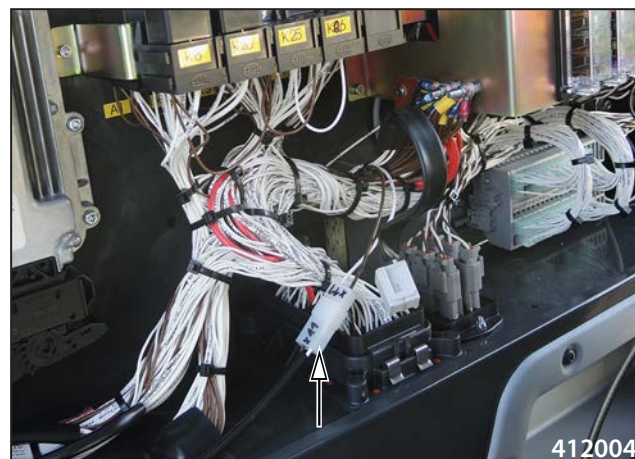

Disconnect the connector.

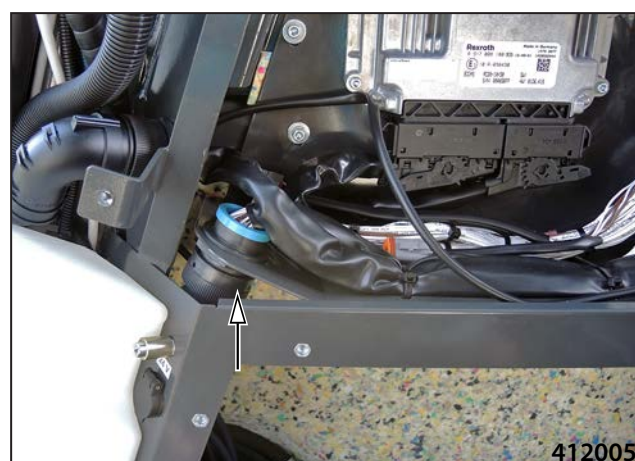

Drain the fuel from the tank. Drained volume 220 l (58,1 gal US).
Disconnect the wire 319 a 341 from the fuel indicator.

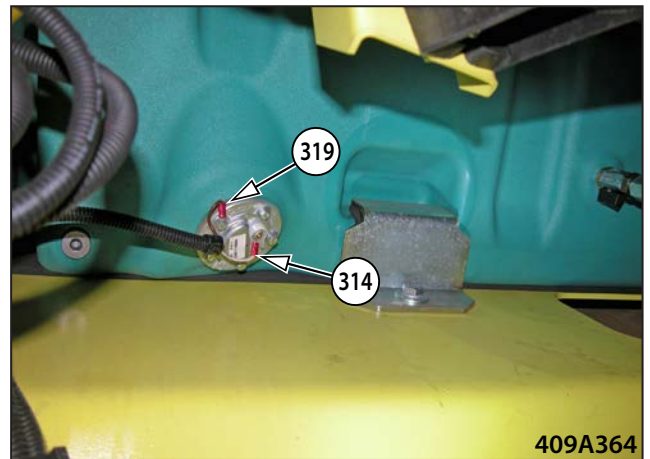

Close the fuel valves (001-110-14). Remove the hoses (001-110-5), (001-110-9).

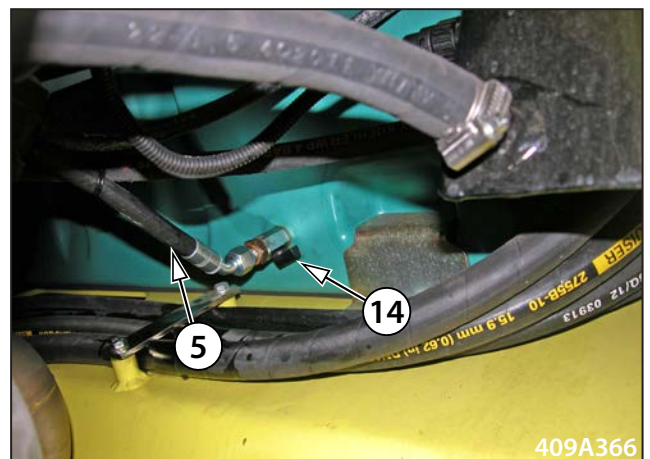
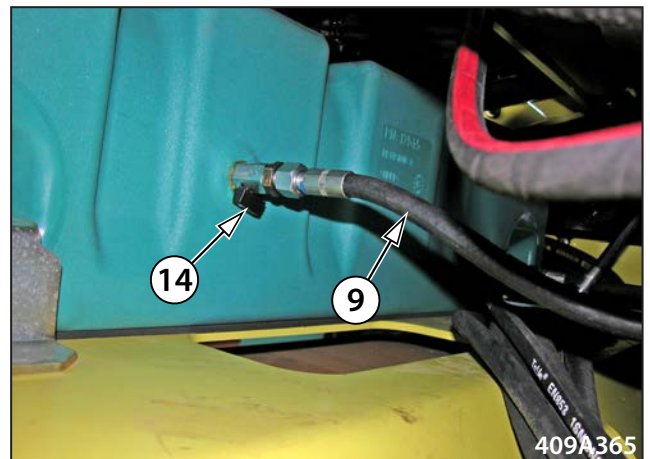

Remove the screws (003-251-19) of the holders (003-251-5).

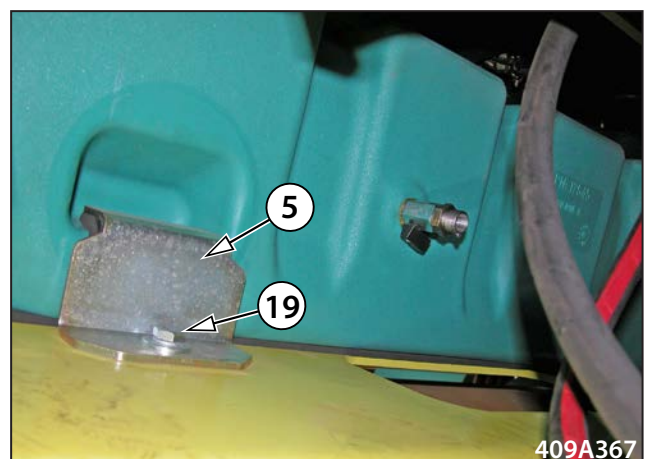

003-061

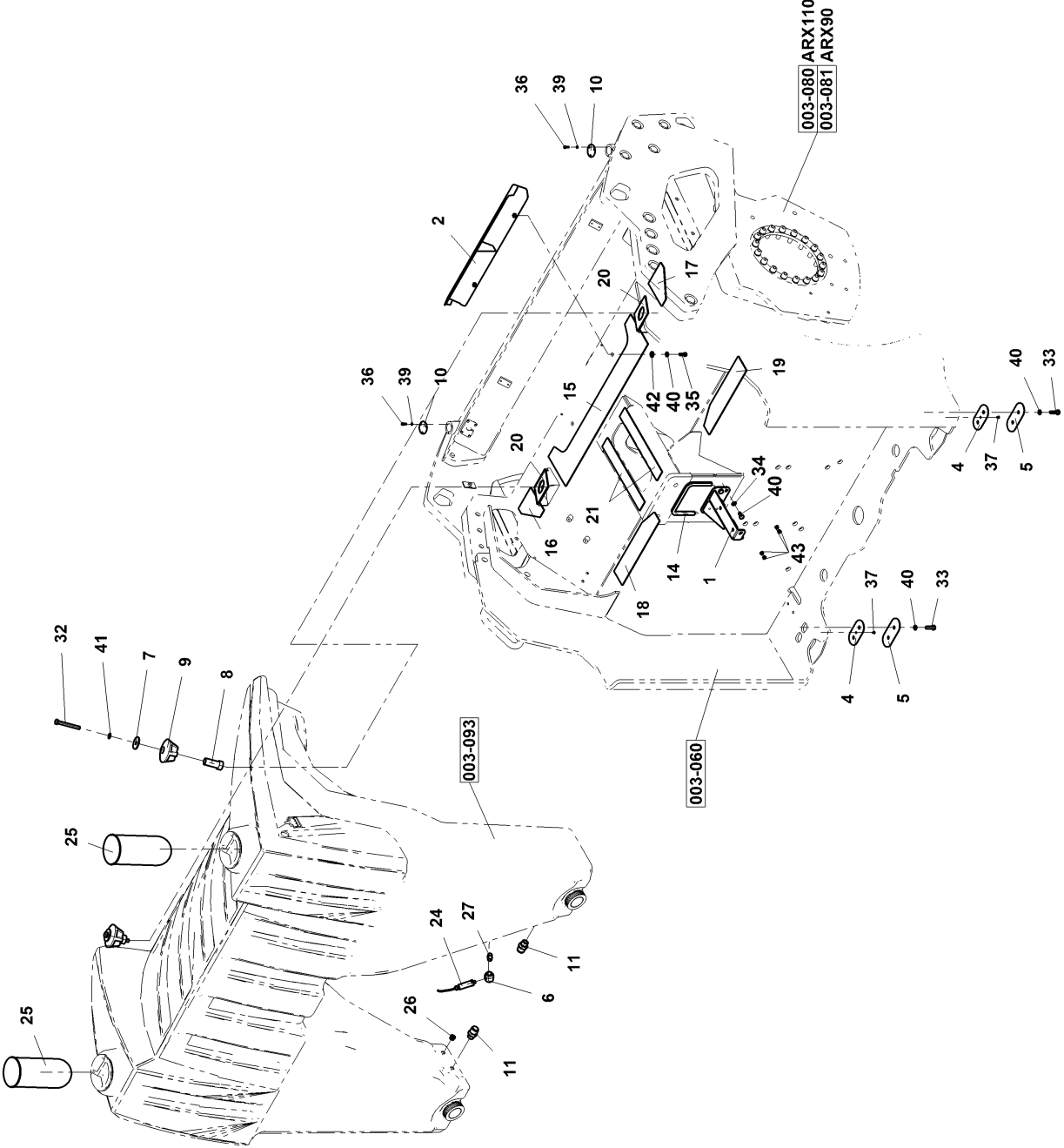

15.3. Fuse positioning

It contains F1 - F28 fuses.

- F1 - 15A Mounting socket
- F2 - 10A front parking lights, front headlamps, rear lights
- F3 - 7.5A rear headlamps
- F4 - 7.5A turn indicators, beacon, horn, cab lighting, coil of engine time relay (A10)
- F5 - 7.5A switch box, lighting relay coils
- F6 - 35A power supply of computer Rexroth RC20-10/30
- F7 - 7.5A seat control
- F8 - 7.5A working lights, drum lighting
- F11 - 5A drum sensors (speed, frequency), el. magnets of vibration, water level sensor, infrathermometer, emulsion sprinkling relay
- F12 - 5A emulsion sprinkling
- F13 - 10A water sprinkling
- F14 - 5A brake lights, reverse horn, alternator excitation
- F15 - 5A total STOP, service mode
- F16 - 1A memory of computer Rexroth RC20-10/30
- F17 - 7.5A lever Gessmann, display
- F18 - 3A diagnostic socket of engine
- F21 - 10A autoradio
- F22 - 10A heating control, rear window heating control, air-conditioning relay
- F23 - 10A wipers, screen washers
- F24 - 10A heating fans
- F25 - 20A rear window heating
- F26 - 5A front working lights
- F27 - 5A rear working lights

In the engine compartment

- F31 - 80A main fuse
- F32 - 15A air-conditioning
- F33 - 10A fuel pump
- F34 - 15A autoradio (memory)
- F36 - 125A pre-heating
- F37 - 30A engine electronics

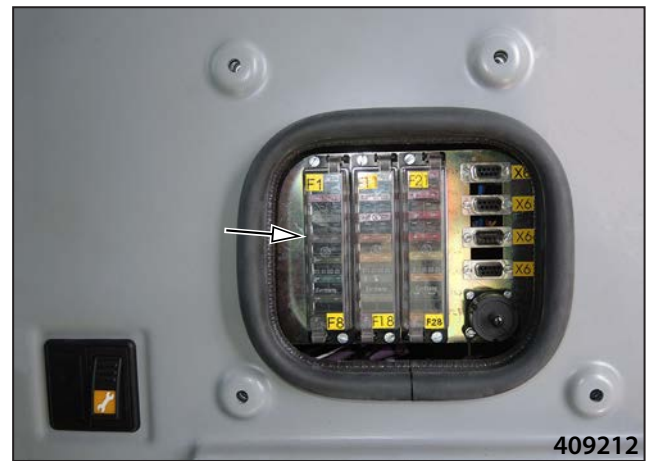

409212

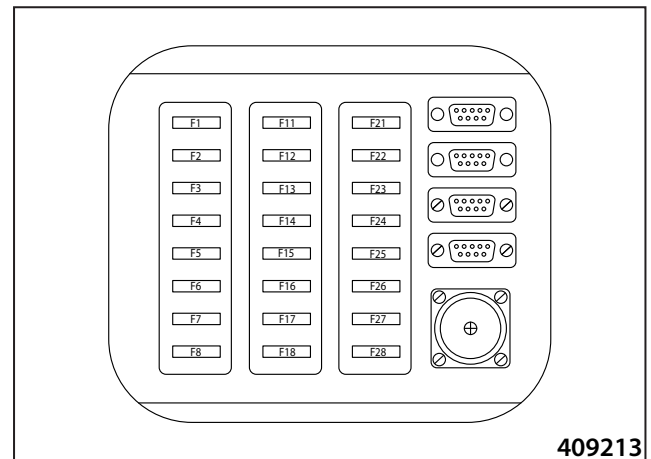

409213



409181



Always replace the fuses with the ones of identical value!

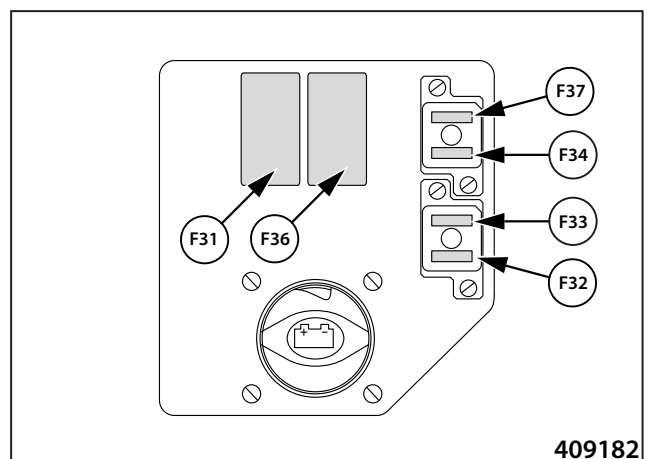

409182

RIGHT ARM REST

Travel lever removal

Dismount the cover.



Disconnect the connectors X1, X2, X3, X4.



Dismount the screws.

Remove the lever.



001-106

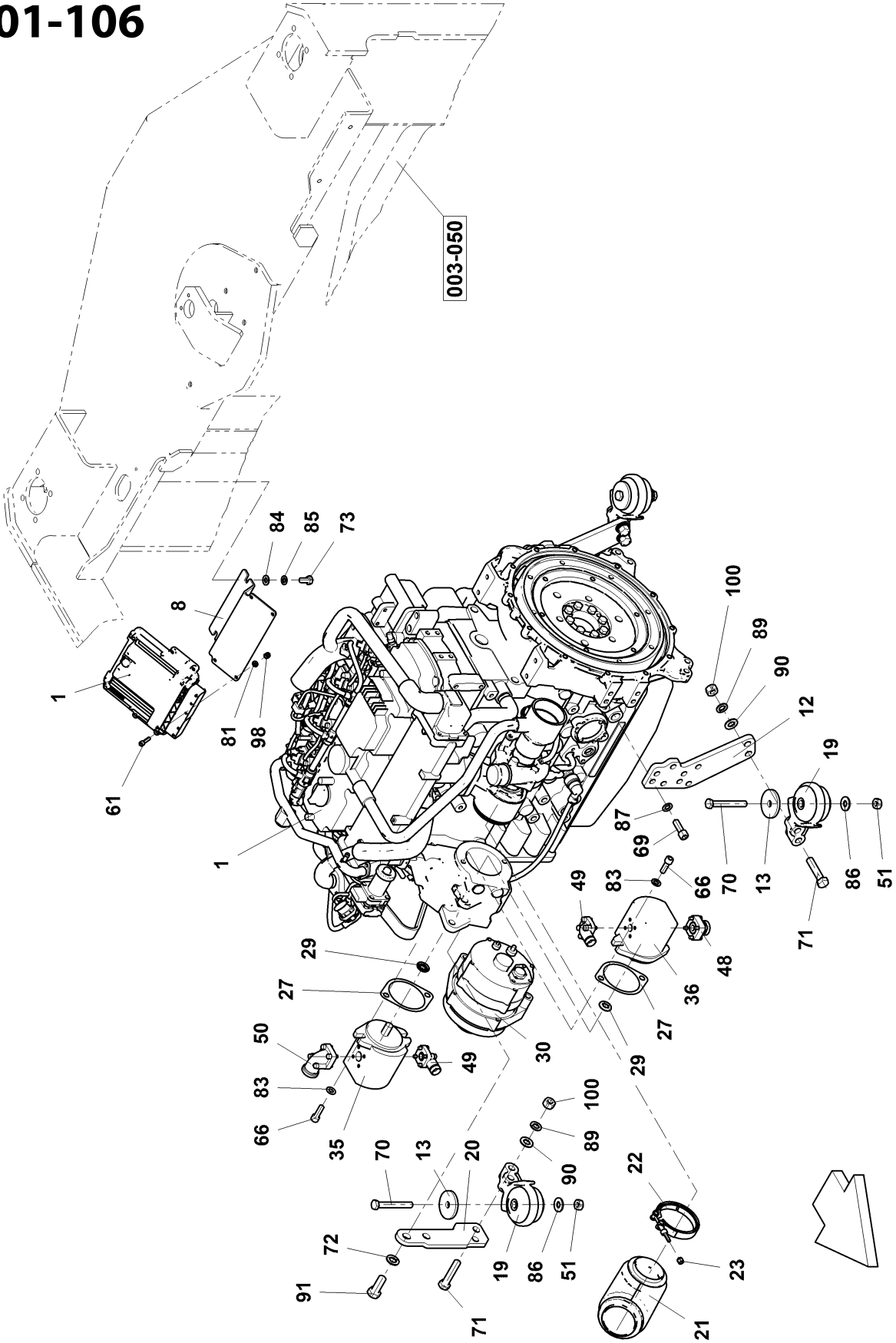

**ARX90 Tier 3
CABLE HARNESS #2 - Wiring system
Part Number 4- 212068 (revision E)**

2.2

CABLE HARNESS LEGEND:

Wire:
R - 1 - 1200 (100)
Wire color Square mm Length Wire number

Cable:
H03VV-F2X0.75 - 2500
Type Length

Corrugated tube:
NW13 - 700
Type Length

X1/3	(203)	X26/6	WH-1.5-3650
X1/14	(214)	X26/11	WH-0.75-3650
X1/15	(215)	X26/1	WH-0.75-3650
X1/17	(217)	X26/12	WH-0.75-3650
X0	(218)	E22	WH-0.75-3550
X0	(219)	E23	WH-0.75-3800
X1/20	(220)	X26/2	WH-0.75-3650
X1/21	(221)	X26/5	WH-0.75-3650
GND	(228)	X26/8	BN-1.5-3650
GND	(229)	X26/9	BN-1.5-5825
GND	(230)	X26/10	BN-0.75-5825
X1/35	(235)	X14/1	WH-0.75-2450
X1/36	(236)	X14/2	WH-0.75-2450
X1/37	(237)	X14/3	WH-0.75-2450
GND	(241)	X20/2	BN-1.5-4200
GND	(242)	X19/2	BN-1.5-4250
GND	(243)	E22	BN-0.75-5800
GND	(244)	E23	BN-0.75-6100
X1/72	(272)	X26/3	WH-0.75-3650
X1/73	(273)	X26/4	WH-0.75-3650
X1/78	(278)	S16/1	WH-0.75-2300
X1/79	(279)	S16/2	WH-0.75-2300
X1/91	(291)	X0	WH-1-125
X1/97	(297)	X20/1	WH-1.5-2100
X1/98	(298)	X19/1	WH-1.5-2150

TABLE OF COLOR SYMBOLS:

WH	B	White
BK	C	Black
BN	H	Brown
BU	M	Blue
RD	R	Red
GY	S	Grey
YE	Y	Yellow
GN	Z	Green

**ARX90 Tier 3
CABLE HARNESS #7 - Wiring system
Part Number 4-212015 (revision C)**

7.2

CABLE HARNESS LEGEND:

Wire:
R - 1 - 1200 (100)
Wire color Square mm Length Wire number

Cable:
H03VV-F2X0.75 - 2500
Type Length

Corrugated tube:
NW13 - 700
Type Length

TABLE OF COLOR SYMBOLS:

WH	B	White
BK	C	Black
BN	H	Brown
BU	M	Blue
RD	R	Red
GY	S	Grey
YE	Y	Yellow
GN	Z	Green

X2/2	(702)	X3/1	WH-0.75-1350	S2/B1	(753)	S2/A3	WH-0.75-80
X2/3	(703)	X62.1	WH-0.75-1300	S2/A3	(754)	S3/A3	WH-0.75-150
X2/4	(704)	S11/B2	WH-1.5-1450	S3/A3	(755)	S39/A3	WH-0.75-150
X2/5	(705)	X63.1	BN-1.5-1300	S39/A3	(756)	S39/B1	WH-0.75-100
X2/6	(706)	X62.1	WH-1.5-1300	S39/B1	(757)	S1/30	WH-0.75-200
X2/15	(715)	X15/15	WH-0.75-1600	S9/B3	(758)	S9/A3	WH-0.75-80
X2/16	(716)	X15/16	WH-0.75-1600	S9/A3	(759)	S9/A1	WH-0.75-80
X2/17	(717)	S3/A4	WH-0.75-1550	S9/A4.1	(760)	S10/A4.1	WH-0.75-150
X2/18	(718)	S39/B2	WH-0.75-1600	S9/A4.2	(761)	S9/A4.3	WH-0.75-80
X2/19	(719)	S311/B2.3	WH-0.75-1450	S9/A4.3	(762)	S10/A4.2	WH-0.75-150
X2/23	(723)	S11/A3	WH-0.75-1550	S11/B1.3	(763)	S2/B1	WH-0.75-275
X2/24	(724)	S11/A4	WH-0.75-1550	X7/5	(768)	R	WH-0.75-75
X2/25	(725)	S1/50a	WH-0.75-1700	X7/6	(769)	R	WH-0.75-100
X2/26	(726)	S11/B1.2	WH-0.75-1550	X62.1	(770)	X62.2	WH-1.5-100
X2/27	(727)	S8/A3	WH-0.75-1500	X3/5	(777)	S21/A4	WH-0.75-400
X2/28	(728)	S8/A4	WH-0.75-1500	X3/4	(778)	S20/A4	WH-0.75-400
X2/29	(729)	S1/15	WH-0.75-1800	X63.1	(780)	X63.2	BN-1.5-100
X2/30	(730)	S11/B1.3	WH-0.75-1550	X15/1	(781)	X4/1	WH-0.75-750
X2/31	(731)	S2/B2	WH-0.75-1500	X15/2	(782)	X4/2	WH-0.75-750
X2/32	(732)	S2/B3	WH-0.75-1500	X15/3	(783)	X4/5	WH-0.75-750
X2/33	(733)	S9/B3	WH-0.75-1475	X15/4	(784)	X4/6	WH-0.75-750
X2/34	(734)	S11/B1	WH-1.5-1550	X15/5	(785)	X4/7	WH-0.75-750
X2/35	(735)	X8/1	CHAINFLEX-C-1350	X15/6	(786)	X3/7	WH-0.75-750
X2/36	(736)	X8/2	CHAINFLEX-C-1350	X15/7	(787)	X3/8	WH-0.75-750
X2/37	(737)	S39/B2	WH-0.75-1600	X15/8	(788)	X4/3	WH-0.75-750
X2/38	(738)	X7/1	CHAINFLEX-C-1350	X15/9	(789)	X4/4	WH-0.75-750
X2/39	(739)	X7/2	CHAINFLEX-C-1350	X15/10	(790)	X4/8	WH-0.75-750
X2/40	(740)	COUPLER	BN-0.75-50	X15/11	(791)	X62.2	WH-0.75-700
X2/41	(741)	S9/A4.1	WH-0.75-1475	X7/4	(792)	X62.2	WH-0.75-200
X2/42	(742)	S9/A4.2	WH-0.75-1475	X8/4	(793)	X62.2	WH-1-200
X2/43	(743)	X62.1	WH-0.75-1300	S21/A3	(794)	X62.2	WH-0.75-400
X2/44	(744)	X63.1	BN-0.75-1300	X7/3	(795)	X63.1	BN-0.75-200
X2/45	(745)	X8/6	CHAINFLEX-D-1350	X8/3	(796)	X63.2	BN-0.75-200
X2/46	(746)	X8/5	CHAINFLEX-D-1350	S9/X2	(797)	X63.2	BN-0.75-375
X2/47	(747)	COUPLER	BN-0.75-50	S11/B2.2	(798)	X63.2	BN-0.75-450
S9/A3.3	(750)	S9/X1	BN-0.75-125	X63.2	(799)	COUPLER	BN-0.75-200
S9/B2	(751)	S10/A3.1	WH-0.75-150				
S10/A3.1	(752)	S10/A3.2	WH-0.75-100				

**ARX90 Tier 3
CABLE HARNESS - Thermometer
Part Number 4-325323**

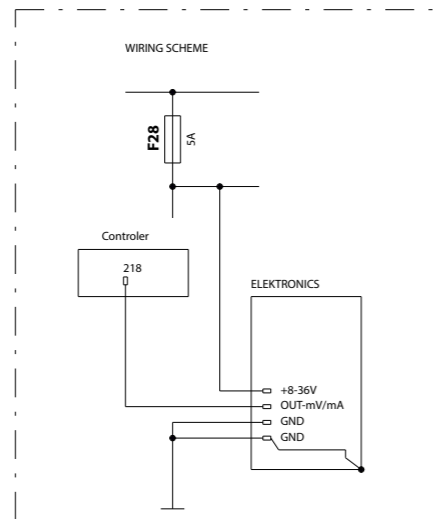
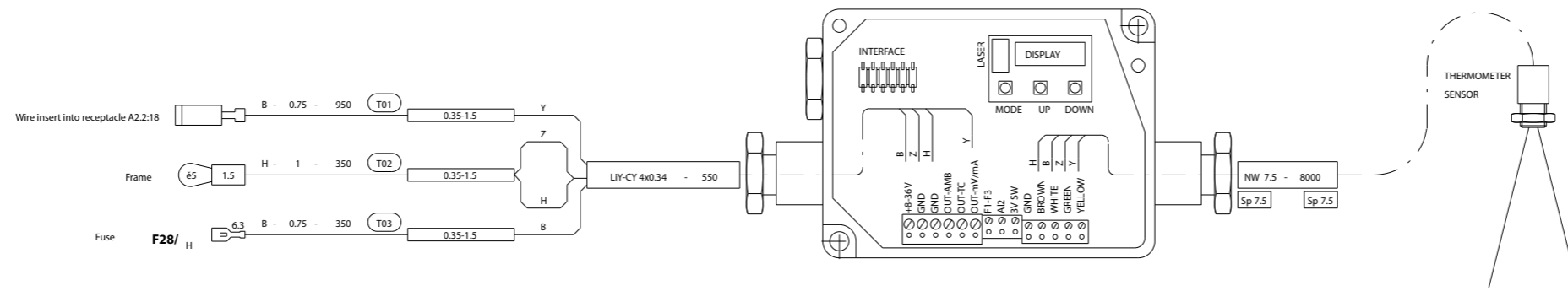

CABLE HARNESS LEGEND:

- Faston
 - Ring tongue
 - Wire ferrule
 - Butt splice
 - Contact
 - Sealing plug
 - Single wire seal
 - Lock nut
 - Insulation sleeve
 - Clip
 - Reducer
 - Clamp
 - T-Manifold
 - Conduit gland SEM straight
 - Faston connector
 - DIN connector
 - DIN connector
 - Receptacle connector
 - Plug connector
- Wire:**
- Wire color → R - 1 - 1200 (100) → Wire number
- Square mm → Length
- Cable:**
- H03VV-F2X0.75 - 2500 → Length
- Type
- Corrugated tube:**
- NW13 - 700 → Length
- Type

TABLE OF COLOR SYMBOLS:

WH	B	White
BK	C	Black
BN	H	Brown
BU	M	Blue
RD	R	Red
GY	S	Grey
YE	Y	Yellow
GN	Z	Green

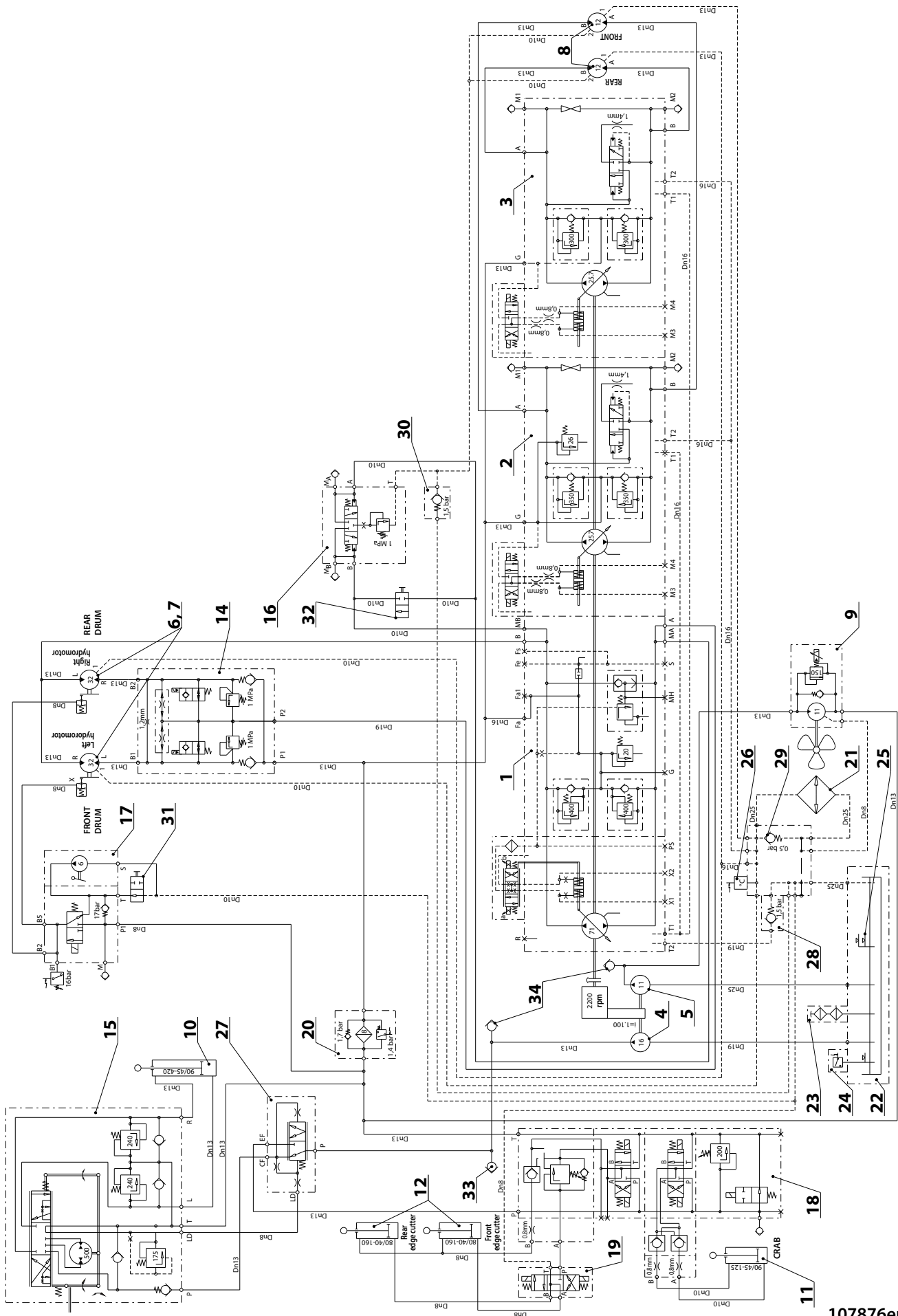

107876en

CLICK HERE TO **DOWNLOAD** THE COMPLETE MANUAL

- Thank you very much for reading the preview of the manual.
- You can download the complete manual from: www.heydownloads.com by clicking the link below



- Please note: If there is no response to CLICKING the link, please download this PDF first and then click on it.

CLICK HERE TO **DOWNLOAD** THE COMPLETE MANUAL