

ARX 23.1 ARX 26.1

TANDEM ROLLER
KUBOTA D1703-M-DI-E4B
EU Stage V, U.S. EPA Tier 4f

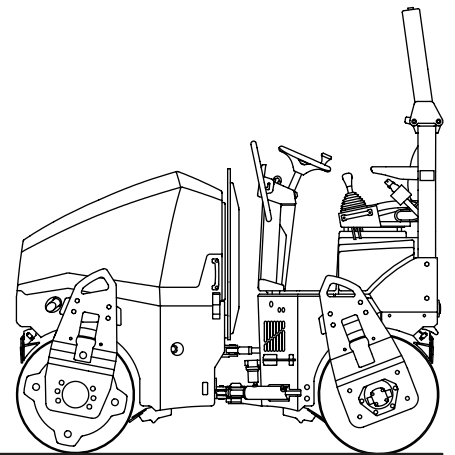

WORKSHOP MANUAL

EDITION 01/2021 EN

ARX 23.1 KU St V / T4f Product Identification Number 3001807 -

ARX 26.1 KU St V / T4f Product Identification Number 3002684 -

AMMANN

CLICK HERE TO **DOWNLOAD** THE COMPLETE MANUAL

- Thank you very much for reading the preview of the manual.
- You can download the complete manual from: www.heydownloads.com by clicking the link below



- Please note: If there is no response to CLICKING the link, please download this PDF first and then click on it.

CLICK HERE TO **DOWNLOAD** THE COMPLETE MANUAL

SAFETY NOTICES AND SIGNS:



The notice warns of a serious risk of personal injury or other personal hazards.



The notice warns of possible damage to the machine or its parts.



The notice warns of the necessity of environmental protection.

! CAUTION!

As used in this operating manual, the terms **right**, **left**, **front** and **rear** indicate sides of the machine moving forward.

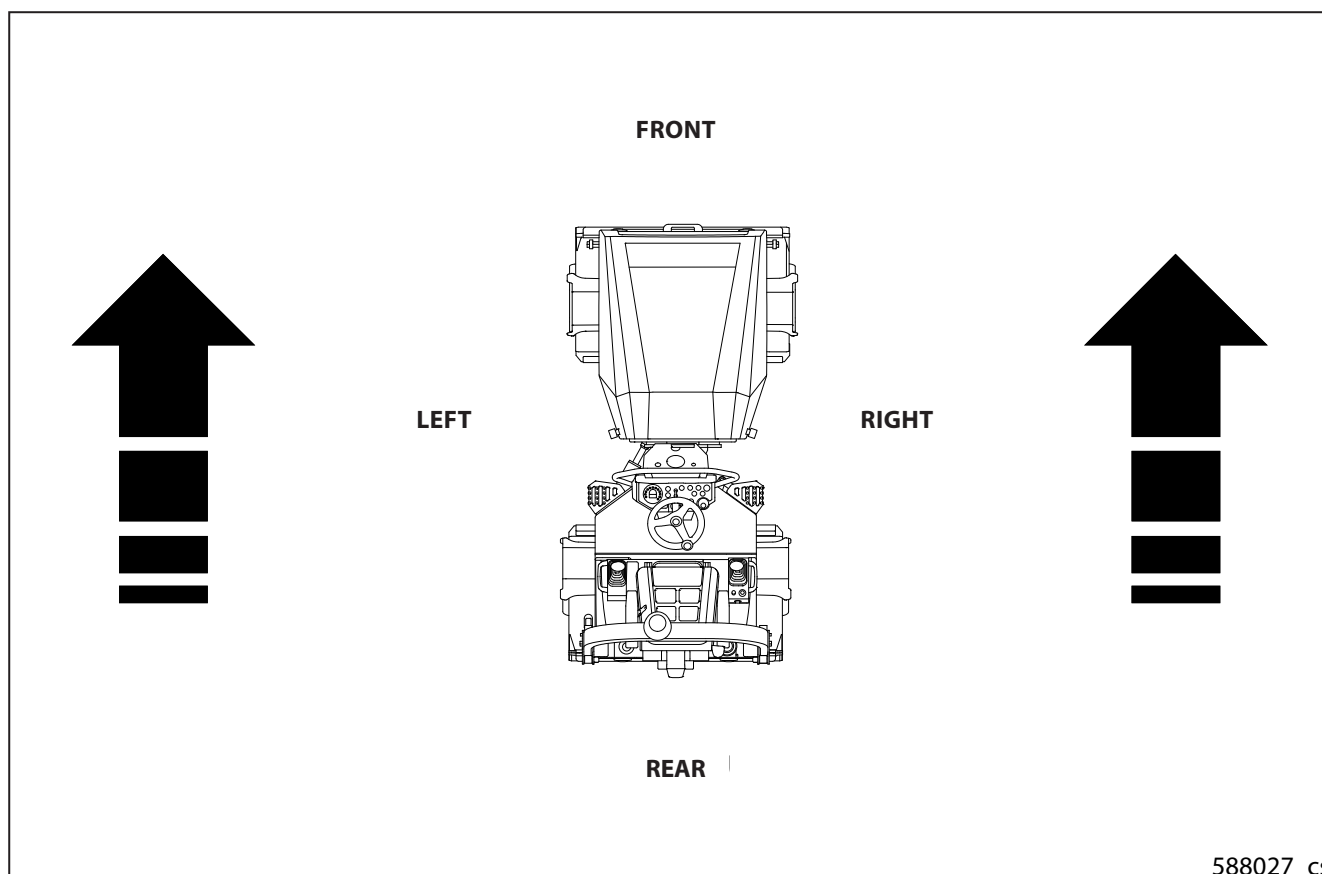

588027_cs

Nameplate position

Nameplate

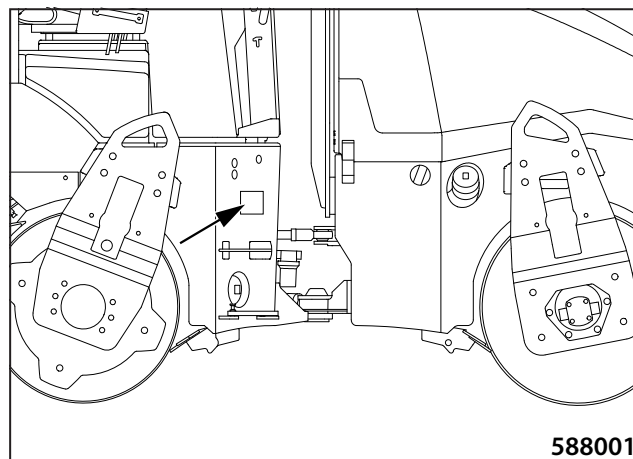

Serial number of the machine frame

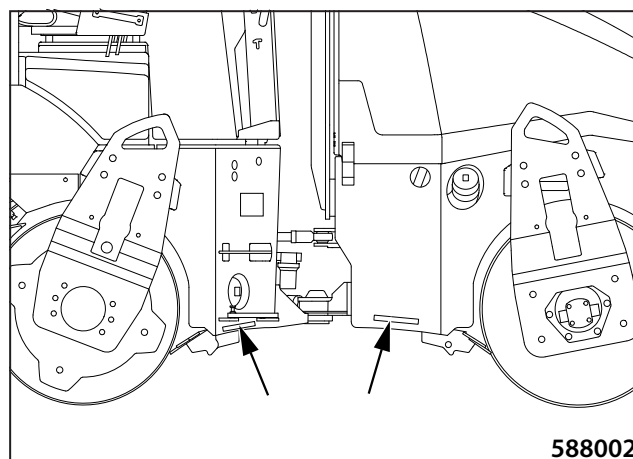

Position of the ROPS nameplate

ROPS nameplate

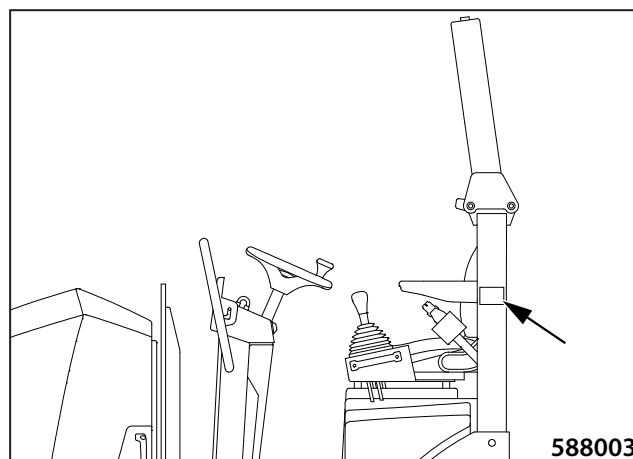

Engine nameplate position

Serial number of the Kubota engine



4.1.4 Hydraulic oil

For the hydraulic system of the machine, it is necessary to use only high-quality hydraulic oil grades according to ISO 6743/HV (equal to DIN 51524 part 3 HVLP).

Fill the machines normally with hydraulic oil that has cinematic viscosity of 46 mm²/s at 40°C (104°F) ISO VG 46. This oil is most appropriate for its use within the widest range of ambient temperatures.

Synthetic hydraulic oil

The hydraulic system can be filled with synthetic oil, which if leakages occur will be degraded completely by micro-organisms present in water and soil.



Please consult always with oil manufacturer or dealer any switching from mineral oil to synthetic one or mixing the oils of various brands!

4.1.5 Lubricating grease

To lubricate the machine you must use plastic grease containing lithium according to:

ISO 6743/9 CCEB 2

DIN 51 502 KP2K-30

4.1.6 Emulsion

For sprinkling the tyres, use anti-adhesive emulsion of RHO-DOSIL EMULSION E1P with water in the mixing ratio of 1.5:100.

5.4.7 Swinging support

5.4.8 Replacement of joint head

- 1 Secure the machine.
- 1.1 Mount a lock against cranking.



- 1 Place the hydraulic jack to the centre of the swinging joint.
- 2 Slightly unload the roller.



- 1 Remove the lower sheet metal.

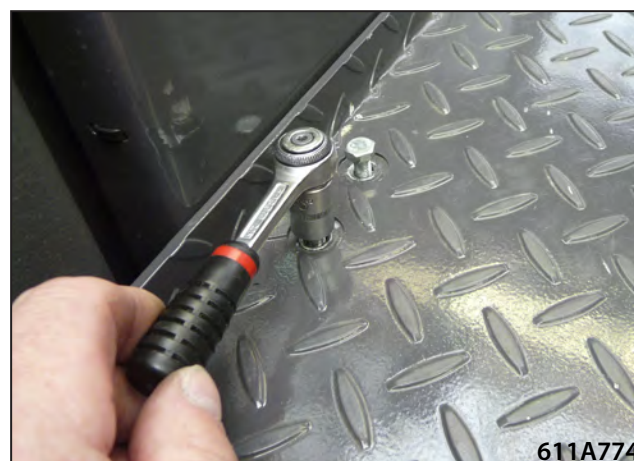

- 1 (3x) Disconnect water piping (1).
- 2 Disconnect the (M4) connector from the water pump.
- 3 Disconnect the (Y9) connector from the shut-off valve.

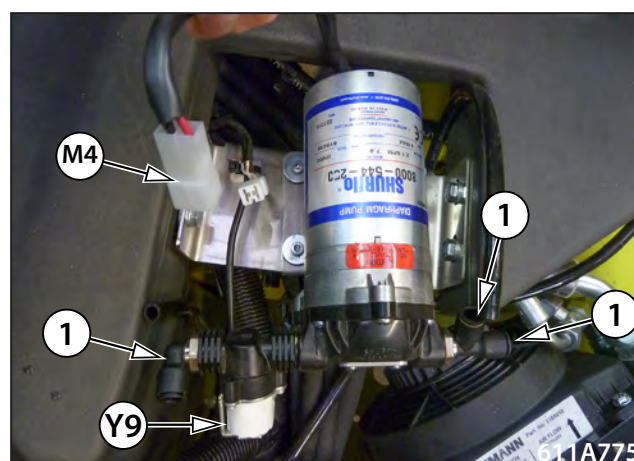

- 1 Secure the screws with a suitable adhesive, e.g. Loxeal 53-84
- 2 Install the clamp.

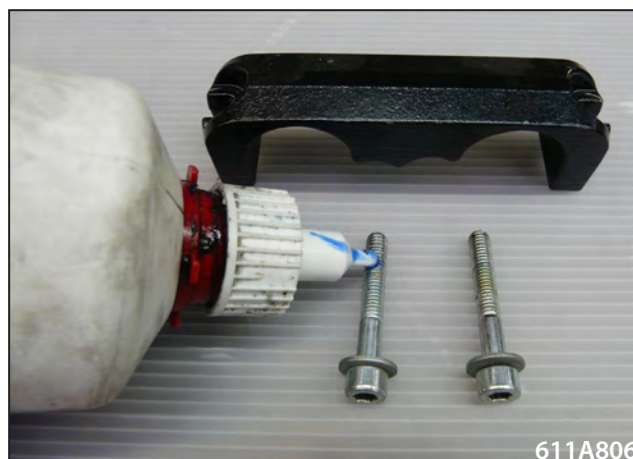
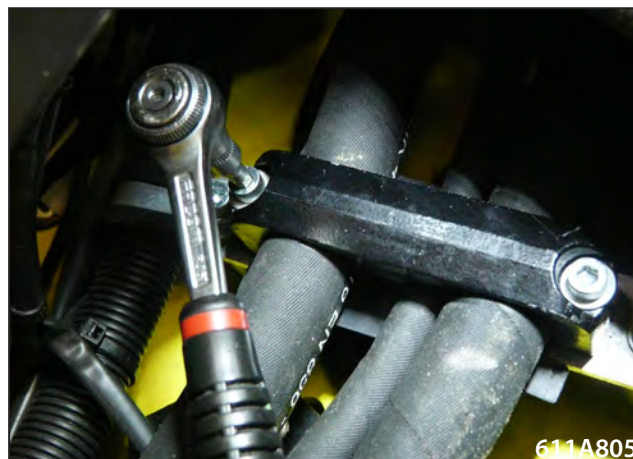

- 1 Re-install hose bundles.
- 2 Fix them using a cable coupling.



- 1 Mount the bearing flange to the chassis using hexagonal screws. Tighten tightly at the tightening torque of 210 Nm.



- 1 Apply the Würth motordich preparation on the bearing, flange and the lid.



- 1 Disconnect water piping.

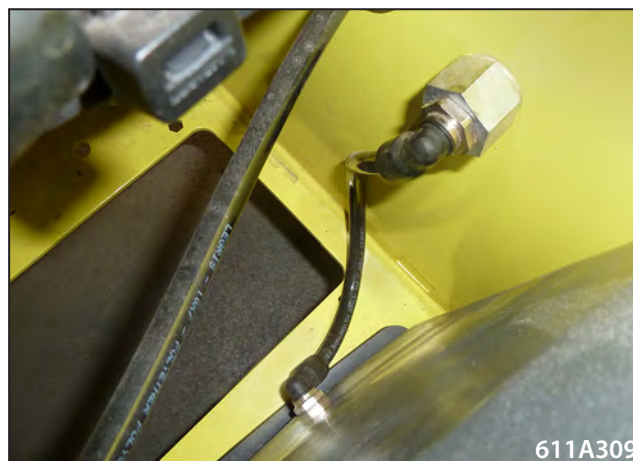

- 1 Disconnect the X9 connector.



- 1 Mount the eye bolt (M8) in the front to the appropriate inner thread.

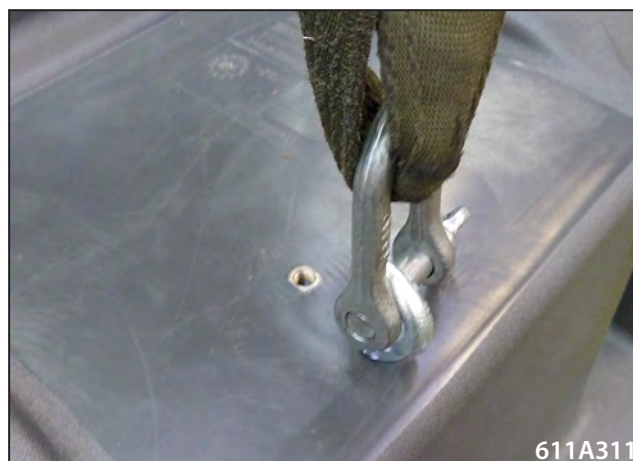

- 1 Now the water tank can be carefully taken out.



Release the canopy by pulling out the lever (1) slightly and raise the canopy.

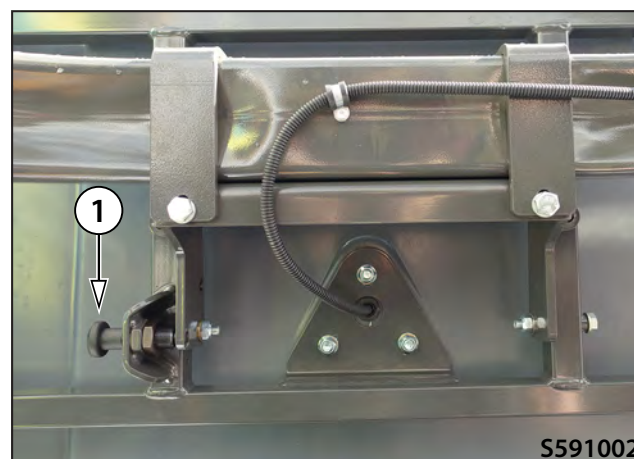

Mount the screws (2x) at the bottom of the plastic canopy.



7 Front drum

- Material:
- 114544 Thrust plate

1 Place the thrust plate on the centre of the shaft.



- Material:
- 114547 Puller tool

1 Screw on the puller tool on the sealing flange.



1 Pre-load the tool using an impact wrench.



1 Heat up the bearing with a gas flame to release it.



1 Insert the SpeedySleeve ring into the assembly tool.



611A455

1 Place the tool on the vibration shaft.



611A456

Using a nylon mallet and the assembly tool for SpeedySleeve ring place the ring to the correct position.



A position of the ring will be determined by the assembly tool



611A457

Mounted SpeedySleeve ring



611A458

- Material:
 - (4x) M8x25 cheese head screw

- 1 Mount the vibration motor on the bearing support with a torque of 25 Nm.



- Material:
 - Screw plug with the inner hexagon G1/4" zinc-plated (1)
 - Seal ring 13.4 / 10.2x1.0 (2)

- 1 Secure the screw plug with a suitable adhesive, e.g. Loxeal 53-84
- 2 Using the screwdriver (SW5) mount the screw plug and the seal ring.

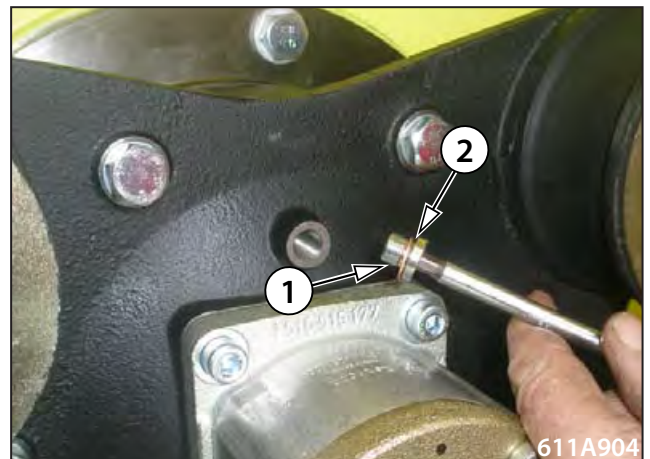

- Material:
 - Screw plug with the inner hexagon G1/4" zinc-plated (1)
 - Seal ring 13.4 / 10.2x1.0 (2)

- 1 Secure the screw plug with a suitable adhesive, e.g. Loxeal 53-84
- 2 Using the screwdriver (SW5) mount the screw plug and the seal ring.

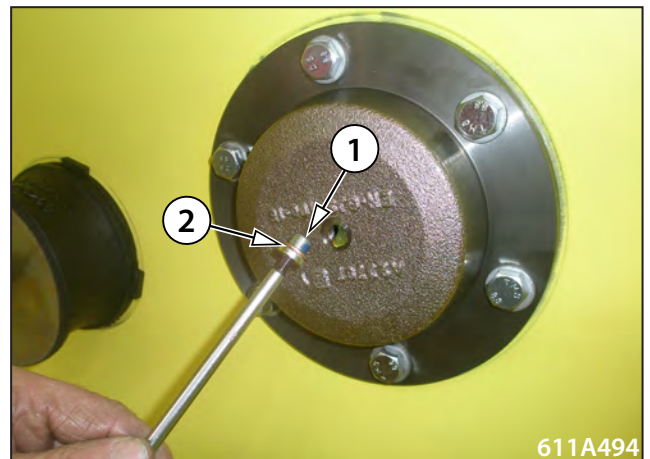

- 1 Introduce the wheel support (1) by means of a crane and locate it on the drum.

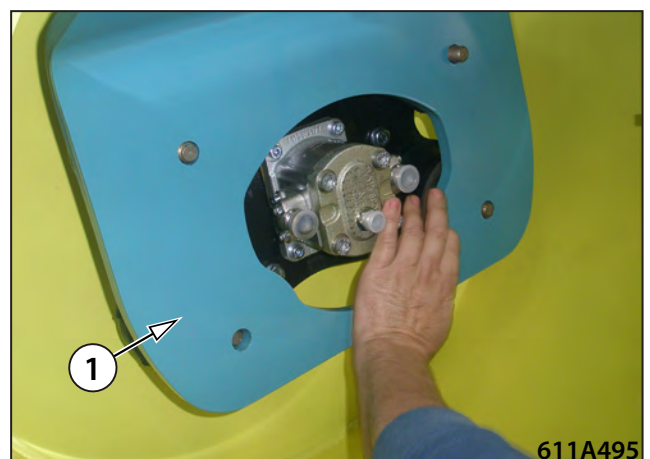

- 1 Place the drum to a suitable workplace.



- 1 Fasten the wheel support on the crane from the side of the travel motor.

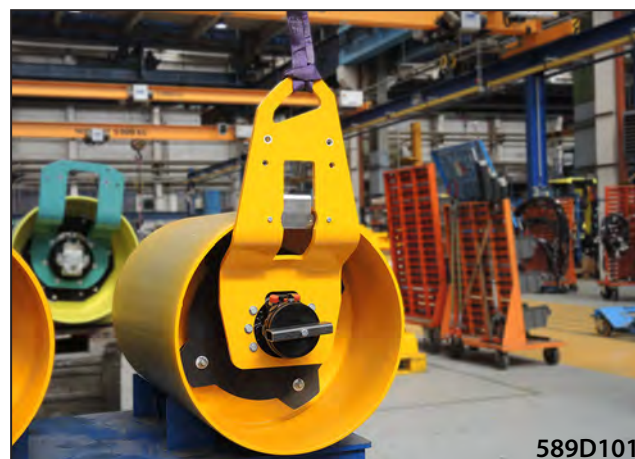

- 1 Fasten the brake equipment to the travel motor.



The wheel support may move.

- 1 (4x) Remove the M16 hexagonal nuts.



8.4.1.3 Drum assembly

Housing pre-assembly

- Material:
 - Housing on the left

1 Clean the housing using a silicon remover.



- Material:
 - Roller bearing NJ 2308 E. TVP2.C3

1 Clean the roller bearing (1) and insert it to the housing.



1 Press the housing (1) and the roller bearing (2) together.

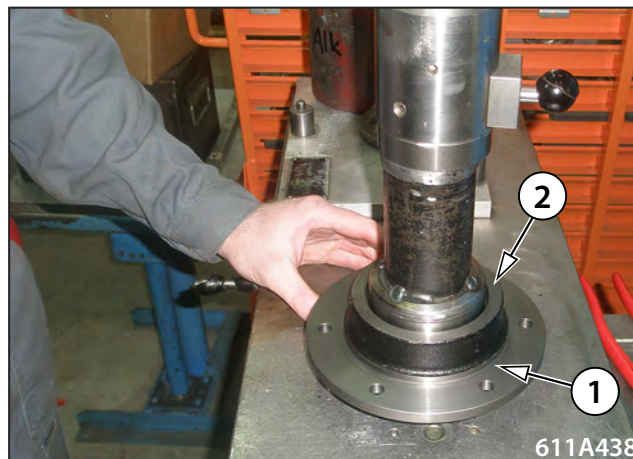

Version with the inner lock ring:

1 Install the inner lock ring.



- 1 Clean the bearing seat with alcohol.



- 1 Apply (green) Loctite 603 on the bearing seat.



- 1 Place a temperature sensor on the inner ring.
 - 2 Heat up the inner ring to the temperature of 110°.
- The value is pre-set by means of the "bearing" symbol (1).



- 1 Mount the heated bearing on the flange.



CLICK HERE TO **DOWNLOAD** THE COMPLETE MANUAL

- Thank you very much for reading the preview of the manual.
- You can download the complete manual from: www.heydownloads.com by clicking the link below



- Please note: If there is no response to CLICKING the link, please download this PDF first and then click on it.

CLICK HERE TO **DOWNLOAD** THE COMPLETE MANUAL

10 Rear axle

11.2 Hydraulic parts

11.2.1 Brake test

11.2.1.1 Check of the parking brake

This test verifies the function of the parking brake. The ability of the parking brake to hold the machine can be checked using the "Brake Test" mode. After starting this mode, the traction force of the machine acts on the stationary machine with the parking brake (P) engaged for a given time.



Perform the test on a level and solid surface.

Check that the area in front of and behind the machine is empty and that there are no persons or obstacles there! Ensure a suitable safe distance in front of the machine, behind the machine as well as on its sides.

Procedure

Place the machine on a flat and solid surface.

Sit in the driver's position and start the engine according to Chapter 2.7.1.

The travel control (11) must be in the parking brake position "P".

Switch to the "Brake test" mode by pressing the brake test button (A) for 5 seconds. While the button is held down, the display shows the "btn br" status.

After 5 seconds, the display shows the "br tSt" status.

Start the test by setting the travel control to the forward travel position.

- The machine must not move off. If the machine moves off, the test is unsuccessful – the machine stops by itself after 3 seconds or it can be stopped by moving the travel control (11) to any position except for the forward position.

The test can be interrupted prematurely by moving the lever anywhere out of the forward position. This stops the traction force. The machine is still in the "Brake test" mode.

For normal operation or to repeat the brake test, stop the "Brake test" mode by moving the travel control (11) back to the parking brake position "P".

To repeat the test, follow the steps above to start the "Brake test" mode.

After an unsuccessful brake test, secure the machine against spontaneous movement by wedges and contact service.

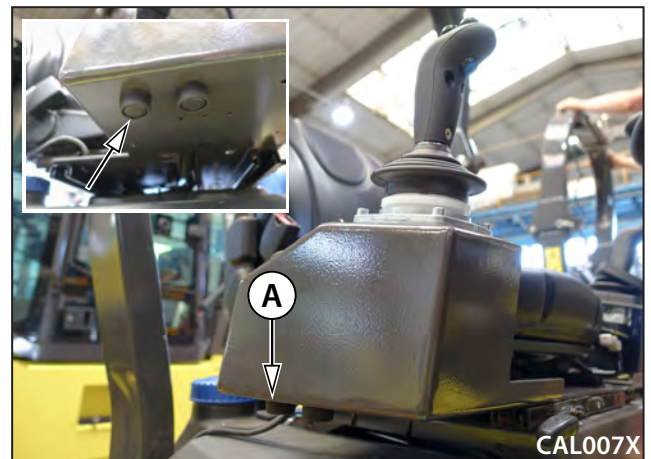
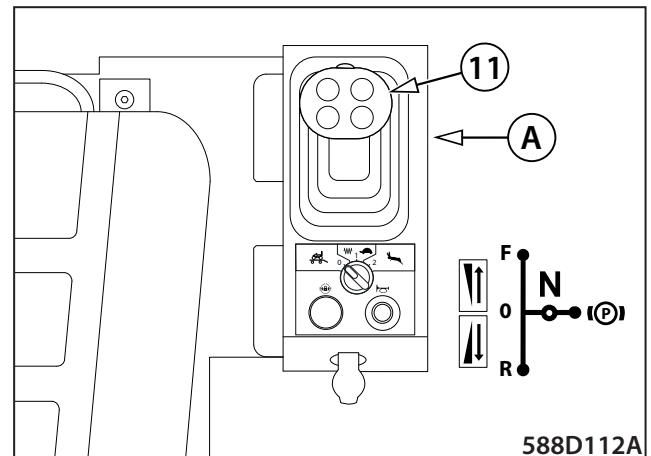

13 Steering

15.1.2 Kubota engine servicing

If you have any questions regarding maintenance and service of the Kubota engine, you can find the relevant information in the Kubota service manual and in the operating manual.

These manuals can be obtained at the on-line platform of Ammann or directly from Kubota.

15.5 Hydraulic oil temperature sensor replacement

When the error code F26 is displayed, check the cable, the connector and replace the sensor.

Drain the hydraulic oil

- Remove the valve (1). Key size 17 mm.
- Mount the hose (2) and the oil drain pan. The minimum drained oil volume is 5 l.
- Start the engine and set the idle speed.
- Be prepared to stop the engine before the oil drain pan is full.

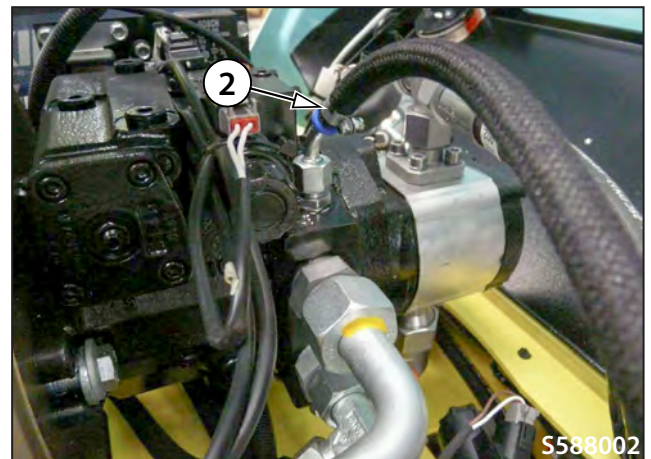
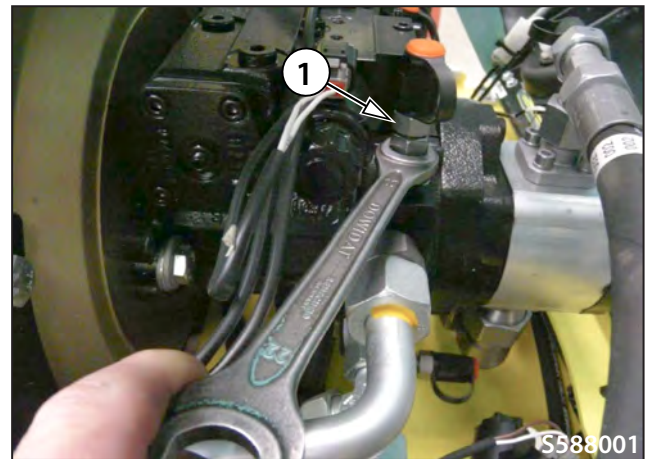

- Secure the articulation joint of the machine against tilting (3).



- 1 Measure resistance of the magnetic coil Y3/Y4.
- 1.1 The resistance value is approximately 6 Ohm.



611A054

- 1 Connect the voltage of 12 V to the magnetic valve.
- 2 The valve (arrow) must visibly switch on.

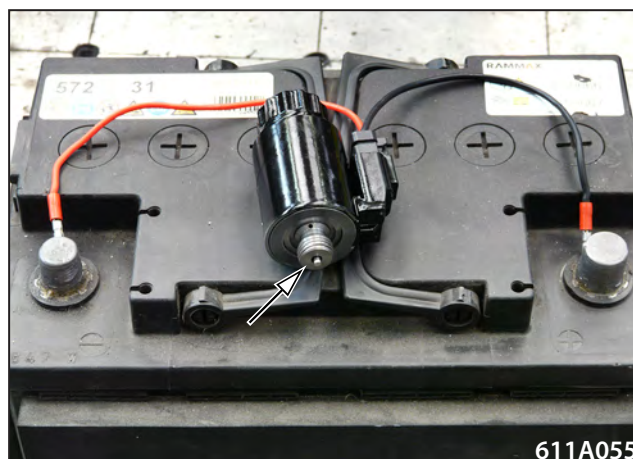

611A055

Change the position of the magnetic coil connector

The position of the connector can be changed by turning the magnet body as needed.

- 1 Release the lock nut (1) of the magnet.
- 1.1 Turn the lock nut (1) by one turn to the left.
- 2 Turn the body of the magnet (2) to the required position.
- 3 Tighten the lock nut again. Tightening torque of the lock nut: 5+1 Nm.

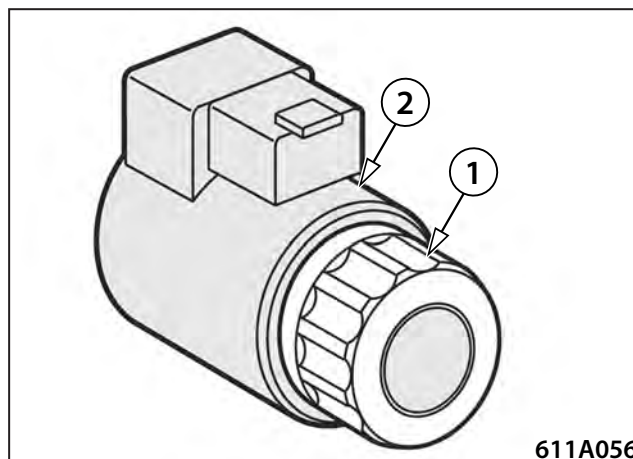

611A056

If the set parameters are not OK, the display shows the "Err" status. The set parameters are not saved and the whole calibration must be repeated.

To complete the calibration, switch off the ignition by turning the key in the ignition box to the "0" position.

To exit the calibration mode without saving, switch off the ignition or press the calibration button for 5 seconds when the tab is not set at B12.

If an error occurs, the message of B12.c "Error" appears on the display. Then it is required to turn off the ignition to the "0" position.

Possible errors:

- Error while saving values (the value is out of range).
- Starting up / turning off the engine in the calibration mode.

Error	Description	Error severity
F300	Intake air temp. error: Low	Low
F301	Intake air temp. error: High	Low
F302	Boost pressure sensor: Low	Low
F303	Boost pressure sensor: High	Low
F304	No input of G sensor (Camshaft position sensor) pulse	Low
F305	G-sensor (Camshaft position sensor) pulse number error	Low
F306	Open circuit of glow relay driving circuit	Low
F307	Ground short of glow relay driving circuit	Low
F308	Glow heater relay driving circuit overheat	Low
F309	QR(IQA) data error	Low
F310	No QR(IQA) data	Low
F311	Main relay is locked in closed position	Low
F312	Ground short of Starter relay driving circuit	Low
F313	Barometric pressure sensor error (Low side)	Low
F314	Barometric pressure sensor error (High side)	Low
F350	Intake air temp. built-in MAF sensor: Low	Low
F351	Intake air temp. built-in MAF sensor: High	Low
F352	EEPROM check sum error	Low
F353	Low coolant temp. in parked regeneration	Low
F354	Parked regeneration time out	Low
F355	Over heat pre-caution	Low
F356	CAN CCVS (ParkingSW and Vehicle speed) frame error	Low
F357	CAN CM1 (Regen SW) frame error	Low
F358	CAN DDC1 (Transmission) frame error	Low
F359	CAN ETC2 (Neutral SW) frame error	Low
F360	CAN ETC5 (Neutral SW) frame error	Low
F361	CAN TSC1 frame error	Low
F362	CAN EBC1 frame error	Low
F363	Error which is out of table. Please connect to ECU and check error with Diagmaster.	Low

- 1 Release apertures and screw them out.
SW may differ depending on the type of the machine. 2.5 + 3 mm.



Apertures must not be loose!! Loose apertures cause problem when driving.

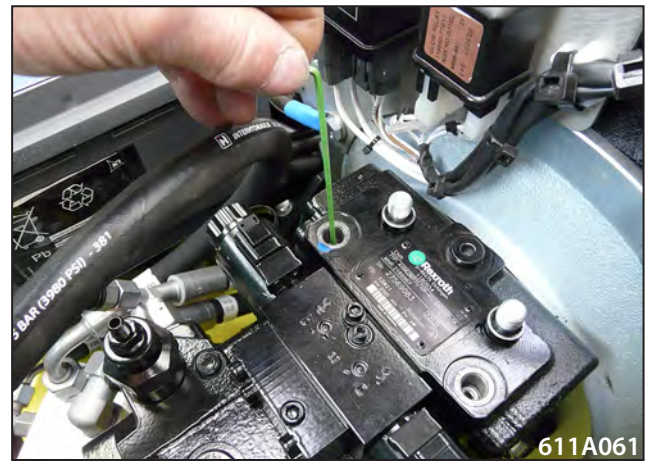

- 1 Loosened apertures are easily taken out by means of a small magnet. Improve as needed.

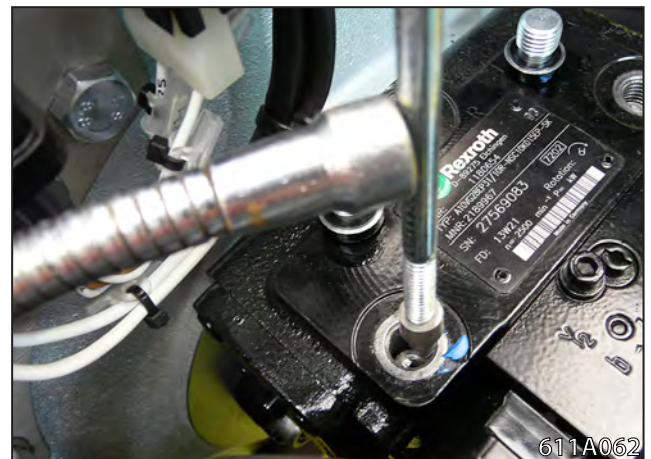

A view of the dismantled aperture holder (1) with apertures.

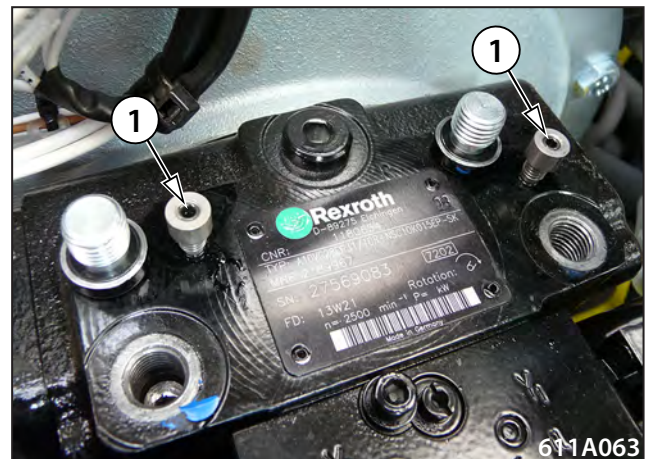

- 1 Loosen the knurled nut.



18.2.9 Brake valve magnetic coil check

Brake valves of ARX 2 only differ in their clamps. The valve is always the same.

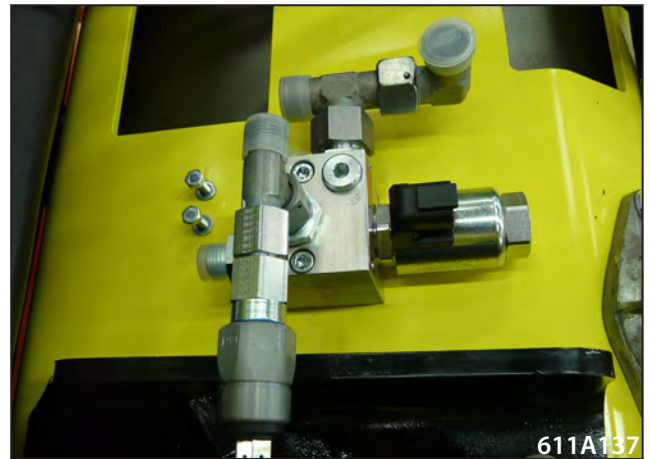

- 1 Dismount the magnetic coil.



- 1 Dismount the magnetic valve.

Note

The maximum torque for remounting is 40 Nm.



A dismantled magnetic valve.

- Nut (1)
- Seal ring (2)
- Magnetic coil (3)
- Magnetic valve (4)

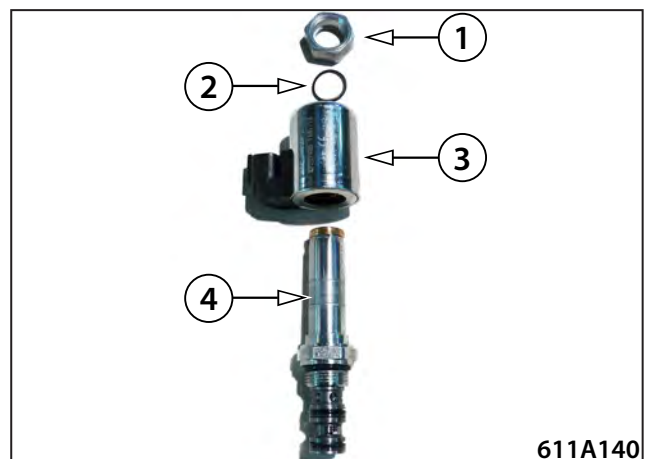

Mount the screws (4x).

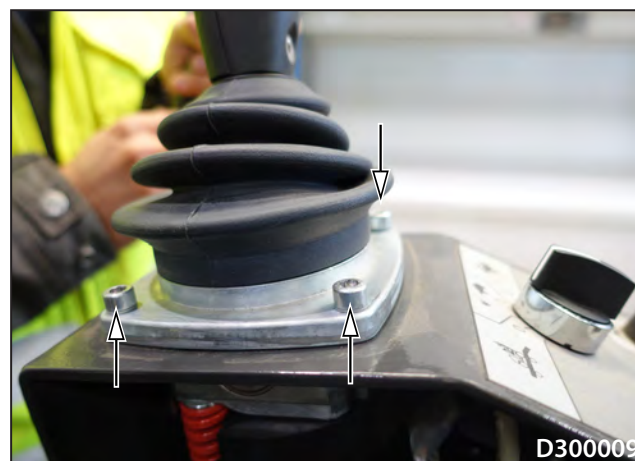

Install the plastic cover.



19.1.1.1 Travel pump magnetic coil check

The travel pump magnetic coil cannot be controlled mechanically.

- 1 Loosen the knurled nut.

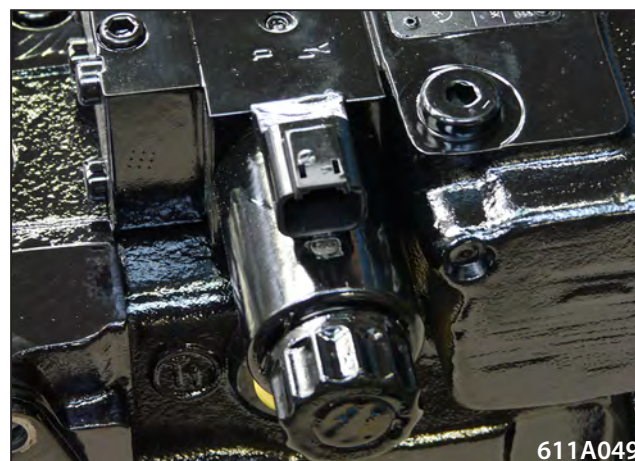

- 1 Dismount the magnetic coil.



















19.3 Electric installations cable harnesses

1.1	Connections.....	39182
1.2	Main harness.....	38857
1.3	Power wiring harness	38864
2	Harness #3	33958
3	Platform harness.....	38936
4.1	Front lights - connections	38300
4.2	Front direction light	34129
4.3	Front position light.....	35541
5.1	Rear lights - connections.....	38302
5.2	Rerar light combined	35543
5.3	Rear direction light.....	35542
6	Beacon	34149
7	Reversing horn.....	34159
8	ROPS lights	34143
9	ROPS beacon lights	34144
10	Green beacon	39605
11	Self-winding belt.....	38950
12	Lights.....	34069
13	Registration plate light.....	34185
14	Seat horn.....	34319
15	ACE Force	39547
16	ACE Force - CM sensor.....	39451
17	ACE Force - HALL sensor.....	35219
18	Teltonics module.....	39695
19	Teltonics harness.....	39698
20	TrackUnit	39591
21	Edge cutter	39243
22	Infrared thermometer	34324

ARX2.1 Tier 4 final
Rear cluster light
Part Number 35543

CABLE HARNESS LEGEND:

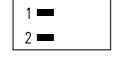
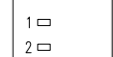
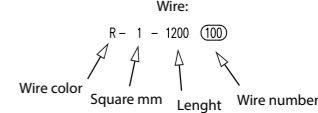
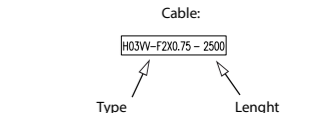
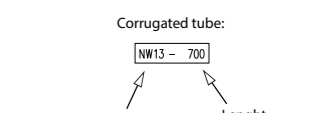
-  Faston
-  Ring tongue
-  Wire ferrule
-  Butt splice
-  Contact
-  Sealing plug
-  Single wire seal
-  Lock nut
-  Insulation sleeve
-  Clip
-  Reducer
-  Clamp
-  T-Manifold
-  Conduit gland SEM straight
-  Faston connector
-  DIN connector
-  DIN connector
-  Receptacle connector
-  Plug connector
- Wire:
 Wire color, R - 1 - 1200 (100)
 Wire color, Square mm, Length, Wire number
- Cable:
 H03VV-F2X0.75 - 2500
 Type, Length
- Corrugated tube:
 NW13 - 700
 Type, Length

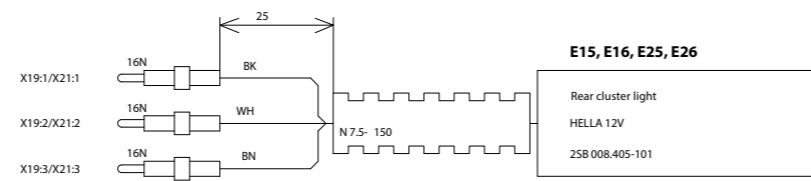
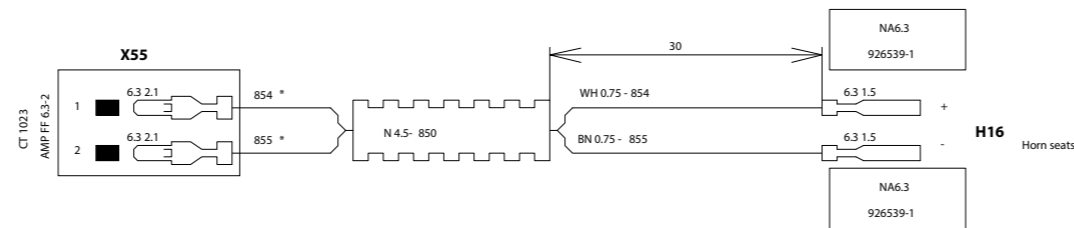

TABLE OF COLOR SYMBOLS:

WH	B	White
BK	C	Black
BN	H	Brown
BU	M	Blue
RD	R	Red
GY	S	Grey
YE	Y	Yellow
GN	Z	Green

ARX2.1 Tier 4 final
 Seat horn
 Part Number 34319



CABLE HARNESS LEGEND:

- Faston
 - Ring tongue
 - Wire ferrule
 - Butt splice
 - Contact
 - Sealing plug
 - Single wire seal
 - Lock nut
 - Insulation sleeve
 - Clip
 - Reducer
 - Clamp
 - T-Manifold
 - Conduit gland SEM straight
 - Faston connector
 - DIN connector
 - DIN connector
 - DIN connector
 - Receptacle connector
 - Plug connector
- Wire:
 R - 1 - 1200 (100)
 Wire color Square mm Length Wire number
- Cable:
 H03VV-F2X0.75 - 2500
 Type Length
- Corrugated tube:
 NW13 - 700
 Type Length

TABLE OF COLOR SYMBOLS:

WH	B	White
BK	C	Black
BN	H	Brown
BU	M	Blue
RD	R	Red
GY	S	Grey
YE	Y	Yellow
GN	Z	Green

CLICK HERE TO **DOWNLOAD** THE COMPLETE MANUAL

- Thank you very much for reading the preview of the manual.
- You can download the complete manual from: www.heydownloads.com by clicking the link below



- Please note: If there is no response to CLICKING the link, please download this PDF first and then click on it.

CLICK HERE TO **DOWNLOAD** THE COMPLETE MANUAL