

Workshop Handbook

66C, 66D turbo

HYDRAULIC SYSTEM

CLICK HERE TO **DOWNLOAD** THE COMPLETE MANUAL

- Thank you very much for reading the preview of the manual.
- You can download the complete manual from: www.heydownloads.com by clicking the link below



- Please note: If there is no response to CLICKING the link, please download this PDF first and then click on it.

CLICK HERE TO **DOWNLOAD** THE COMPLETE MANUAL

66 C turbo 66 D turbo

Group 2200

HYDRAULIC SYSTEM

Group 1700

STEERING SYSTEM

LOADER and STEERING HYDRAULICS

Hydraulic and electrical circuit diagram (3-spool control valve and return to dig system)

Fig. M 304

Electrical components

E 57	Batteries
E 9	Starter motor
E 82	Multiple-blade connector (14 connections)
E 43	Thermostat starter switch
E 85/I	Fuse box
E 85/II	Fuse box
E120	Permanent magnet
E117	Magnetic field switch
E139	Relay (automatic, boom kickout system)
E116	Solenoid (loader lift detent)
E116a	Solenoid (float detent)
E118	Diode
E209	Relay (return to dig system), right
E210	Relay (return to dig system), left
E113	Cable junction box
E128	Cable connector
E215	Magnetic field switch
E216	Magnetic field switch
E212	Indicator lamp (left)
E211	Indicator lamp (right)
E213	Solenoid (bucket dump detent)
E214	Solenoid (bucket crowd detent)
E 28	Battery charging warning lamp
E 30	Engine lubricating oil pressure warning lamp
E111	Emergency steering pump warning lamp

Pressure test points:

- A Pressure test point for pressure from the pressure relief valve 14a
- B Pressure test point for pressure from the unloading (regulating) valve 7 d
- C Pressure test point for pressure from the pressure relief valve 8 a
- D Pressure test point for pressure from the Servo circuit pressure holding valve 12 with engine running, and from the pressure reducing valve 14 h with the engine stationary and loader frame raised.

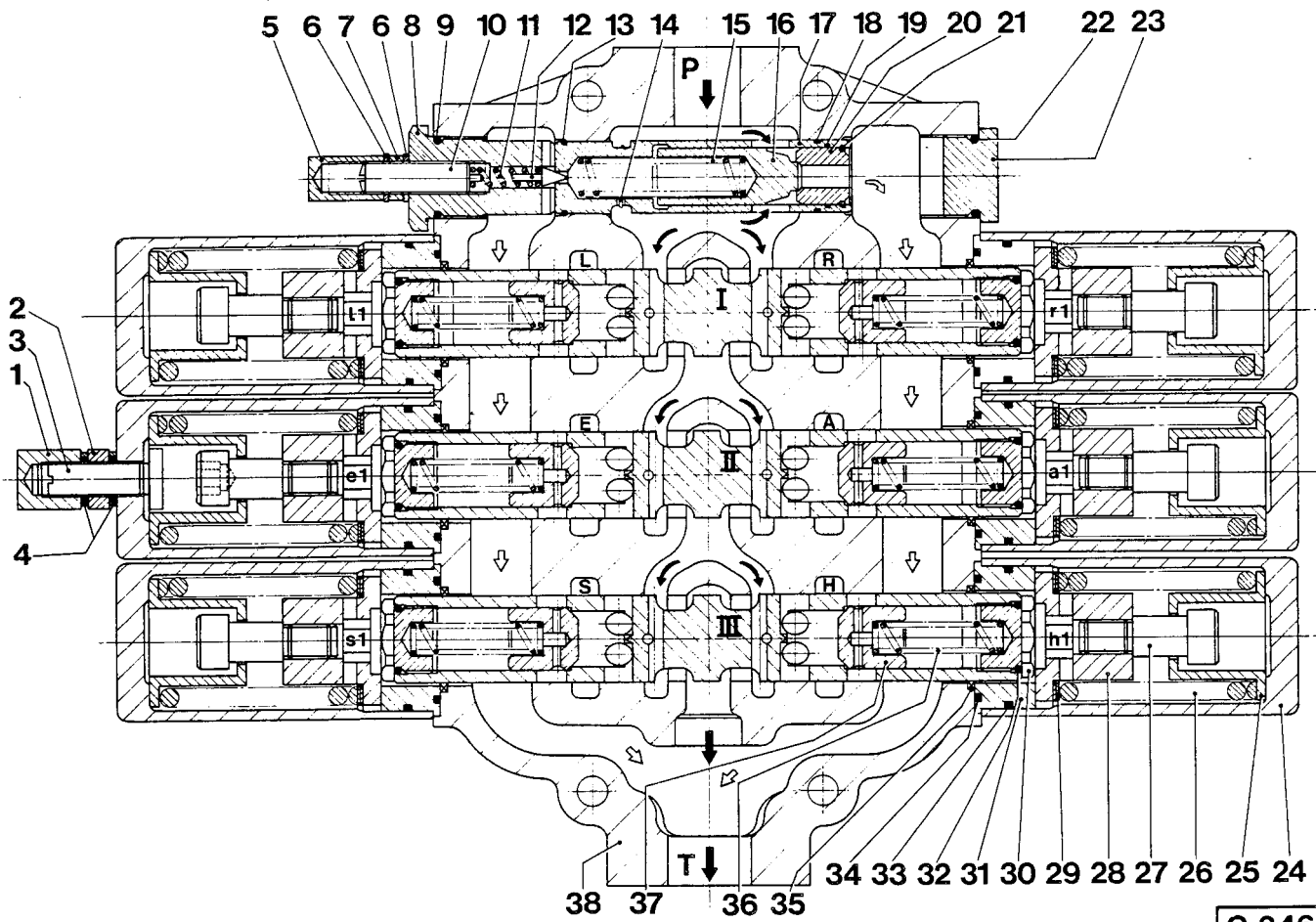

G 346

LOADER HYDRAULICS

Hamworthy float spool and pressure reducing valve (emergency lowering valve)
installed in the V 1013 DDA 55 VS control valve

Fig. G 347

Function of the emergency lowering valve

On servo operated hydraulic systems without an emergency lowering valve, dumping the bucket and lowering the loader frame will not be possible should the servo pump fail.

In the event of servo pump failure, an emergency lowering valve will direct the static pressure trapped in the loader lift cylinder and main control valve into the servo control circuit at a reduced pressure to enable further operation of the main control valve.

When the servo pump is operating normally the line P will be under influence of servo pressure. This pressure is felt back to the rear face of the plunger (10) via the drilling in the plug (13). The plunger will move to the left against tension of the springs (2 and 3) and close the gallery (H) from the servo control circuit.

When the servo control pressure in line P drops due to failure of the servo pump, the tension of the springs (2 and 3) will move the plunger (10) to the right until the annular groove of the plunger opens the gallery H to the gallery X. The static oil trapped in the Gallery (H), which is under induced pressure influence due to the weight of the loader equipment and the load it is carrying acting on the loader lift cylinder piston rod, will now flow at a reduced pressure from the gallery H into gallery X and into the servo control line (P) via the check valve (V) providing the pressure necessary for the operation of the servo control circuit. This pressure is also felt back on the rear face of the plunger (10) moving the plunger to the left against spring (2 and 3) tension until the gallery H is blocked off from the gallery X.

The gallery H will remain blocked off from gallery X when the main control valve is subsequently operated by the servo control valve to lower or dump the bucket.

To prevent an excessive pressure build up of servo pressure due to leak oil at the plunger (10), a pressure relief valve is located inside the plunger.

Should the pressure in the gallery X exceed the nominal value, the poppet valve (9) will open and relieve the excess pressure by discharging oil into the gallery (t) and back to the oil tank.

Valve adjustment:

1. Pressure reducing valve for emergency lowering:

With the engine stopped and the loader frame raised, check the pressure at the servo control circuit pressure test point.

To adjust: Support the loader frame, stop the engine and relieve system pressure by opening the oil tank vent screw. Adjust by adding or removing shims behind the springs (2 and 3).

2. Pressure relief valve:

Remove the cap (1), springs (2 and 3) and travel stop (4). Slacken the nut (6) and screw in the adjusting screw (5) until it abuts the spring (8) then screw it in a further 4 mm and tighten the nut (6). Replace the travel stop, springs and cap. The correct pressure is now set, therefore, a pressure test will not be necessary.

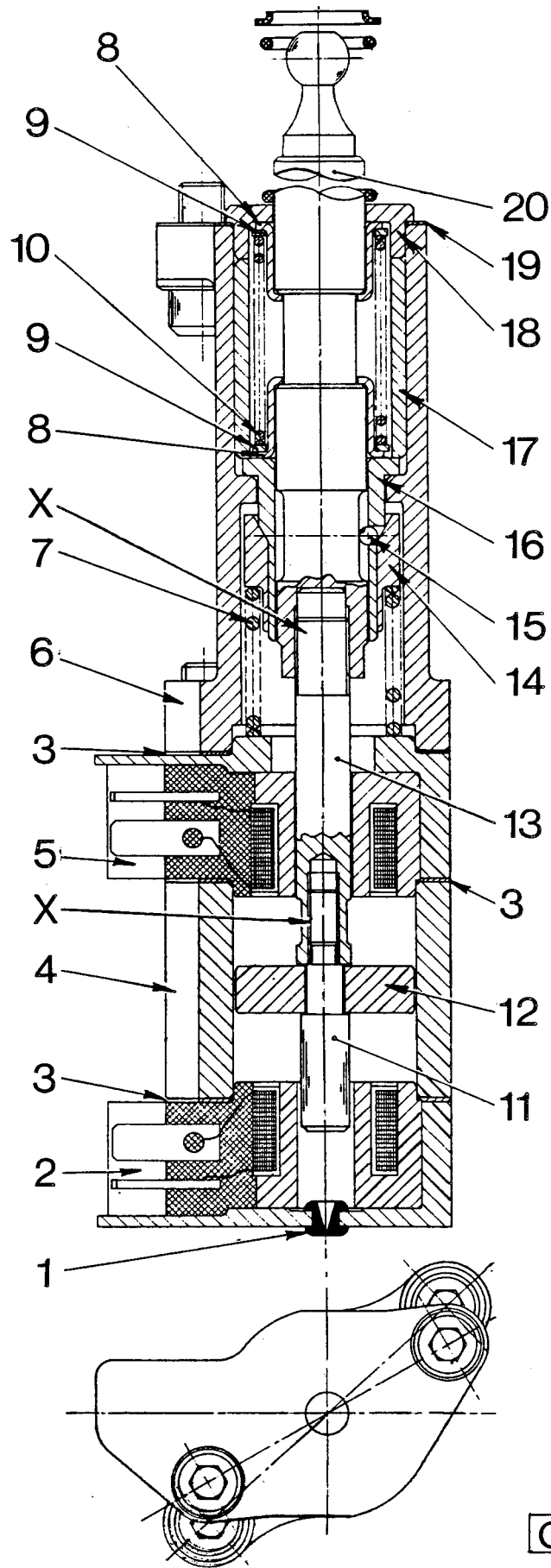

STEERING SYSTEM

Steering valve block

Fig. L 932

Should the main steering hydraulic system (steering pump) fail, the steering valve block automatically directs the output of the emergency steering pump into the main system to maintain system operation.

- 1 Inlet port from demand/regulating valve
- 2 Inlet port from emergency steering pump
- 3 Outlet port to steering
- 4 Outlet port to hydraulic oil tank
- 5 Steering circuit pressure relief valve 180 bar
- 6 Emergency steering circuit pressure relief valve 100 bar
- 7 Shock valve 400 bar
- 8 Emergency steering circuit flow indicator
- 9 Emergency steering circuit warning lamp
- 10 Pressure test point M14 x 1.5

WORKING (LOADER) HYDRAULIC SYSTEM

When the engine is stationary (hence no output from the servo pump) and with the loader arms raised, the weight of the loader equipment will increase the static pressures in the cylinders (15) (piston side). This pressure, via the valve arrangement (22), will be reduced and owing to the non-return valve (25) in the servo control circuit will be routed to the servo control valve (14), thereby allowing further operation of the consumers even when the servo pump has failed, e. g. emergency lowering.

The spool valve (26) in the servo control valve (13) can be locked (detent) in the lift and float positions. The lift position is locked by an electro-magnet (27) via the magnetic field switch (18) which is adjusted by the driver to the desired kick-out height. To prevent the electro-magnet (27) remaining too long under electrical tension, a timer (17) with a connection duration of 1,2 seconds is installed.

With the actuation of the spool valve (28) of the servo control valve (13) a consumer circuit will be connected via the directional valve (19). This directional valve will regulate the pressure at the 2-stage pressure relief valve (21) which is installed in the circuit from 180 bar (2610 psi) to 120 bar (1740 psi), thereby ensuring that the bucket cylinder circuit pressure is regulated to a maximum of 120 bar (1740 psi).

The hydraulic oil is kept within the desired temperature range by the heat exchanger (10). As only a portion of the oil is required for the cooling process, the heat exchanger is installed in the return flow circuit (31) of the steering system.

The by-pass valve (29) protects the heat exchanger from excessive pressures.

DEMAND/REGULATING VALVE

Fig. F 739

Regulating valve

Regarding the control of the working hydraulics requirements, first let us consider the channel connecting the demand valve with the working hydraulics system (connection 34).

The illustration (F 739) shows the channel blocked off by the pressure control spool (4), so that the oil in this channel will react on the check valve (7) opening the valve cone (10) allowing the oil to combine with the oil in the working hydraulics pump circuit. This oil flow combination will continue to exist until the switch-over point (regulating pressure) is reached.

The switch-over point is pre-set by altering the tension of a spring by means of the adjusting screw (15) which braces the control spool (1) and the control piston (2). When the pre-set switch-over pressure is reached the effect will be a displacement of the control piston (2) equal to the occurring working hydraulics pressure. As the control piston (2) braces the control spool (1) a positive displacement of the control spool will take place. With this displacement of the control spool an admission of pressure oil from the working hydraulics into the cylinder bore of the pressure control spool (4) will occur. This admission of oil will cause the pressure control spool (4) to suddenly move against the tension of the return spring (5) leaving the way free for the oil that was deviated from the switch pump (31) to the working hydraulics (34) to return to the oil tank via the connection (35).

In this condition the working hydraulics is supplied by the oil delivered by the working hydraulics pump only until such time the working hydraulics pressure increases and reaches the pre-set pressure of the 2-stage pressure relief valve installed in the main control valve.

SERVO CONTROL VALVE
(3-spool)

Cross sectional view

Fig. G 88

- 2 Bucket spool valve (Tip-in and Dump-out)
- 3 Loader spool valve (Lift, lower and float)
- 6 Spool valve for supplementary attachments
- 7 Magnet - "lower" detent (max. height kick-out)
- 8 Switch for bucket "Tip-in" and "Dump-out"
This switch operates the 2-stage pressure relief valve
in the control valve via the directional valve
- 9 Adjusting point of the switch (8)
- 10 Control lever for loader equipment
- 11 Control lever for supplementary attachments

CONTROL VALVE

Secondary pressure relief valve (shock valve), testing

Fig. F 372

- 1 = Valve for bucket tip-in
- 2 = Valve for bucket dump out
- 3 = Valve for loader arm lift

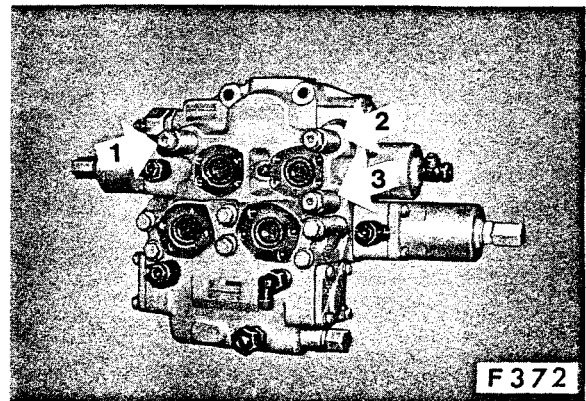

Test instruction I:

Fig. G 1

Testing with the simple to operate OTC-hand pump, type Y-21-1 incorporating a pressure relief valve of 700 bar (10 150 psi) and a pressure gauge of 0 - 400 bar (5800 psi). Other available hand pumps, e. g. track pin press, can also be used.

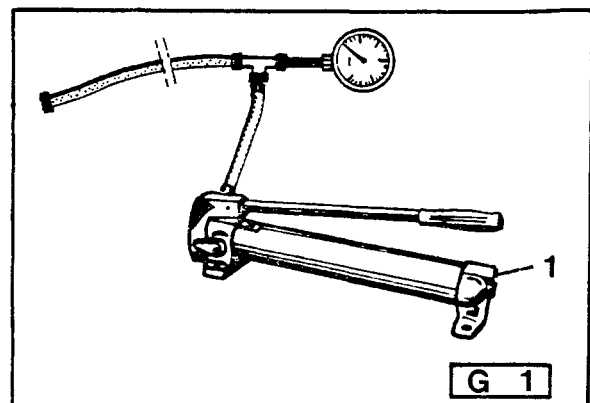

Connecting the hand pump:



Fig. E 230
Support the loader arms and dump out the bucket. Depressurize the system.

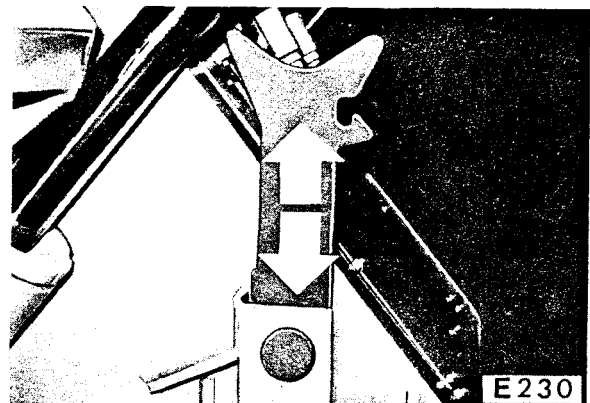
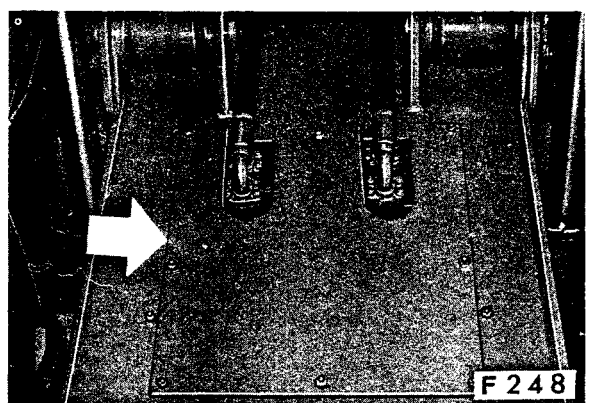

Fig. F 248

Remove the cover plate.



PRESSURE RELIEF VALVE

(Servo control)

Pressure testing and adjusting

Note: The testing and adjusting of the pressure is to be carried out with the working hydraulic's oil warm.

Testing the pressure:

Fig. F 701

The pressure test point (1) for the pressure relief valve (2) is to be found at the right hand side of the distributor gearbox.

Articulate the machine onto left hand lock and stop the engine.

Unscrew the test point screw cap (1) and connect a 0 -25 bar (0 - 362 psi) pressure gauge.

Start the engine.

Pressure = 18,5 bar (268 psi) at maximum engine speed.

In the lower speed range this pressure will not be reached. The pressure will therefore be between 13 - 18,5 bar (188 - 268 psi) depending on engine speed.

Adjusting the pressure:

Figs. F 702 and F 703

The pressure relief valve is to be found on the right hand side of the powershift transmission.

Unscrew the cap nut (1) and loosen the lock nut (3).

To increase the pressure, screw IN the adjusting screw (4).

To decrease the pressure, screw OUT the adjusting screw (4).

Finally tighten the lock nut and replace and tighten the cap nut. Do not forget the seals (2) !

Fig. F 703

A = Connection from the servo hydraulic pump

B = Connection to the servo circuit

C = Return flow to oil tank

D = Pressure test point (plugged)

For clarity the connections A and B are illustrated at 90° to their actual position.

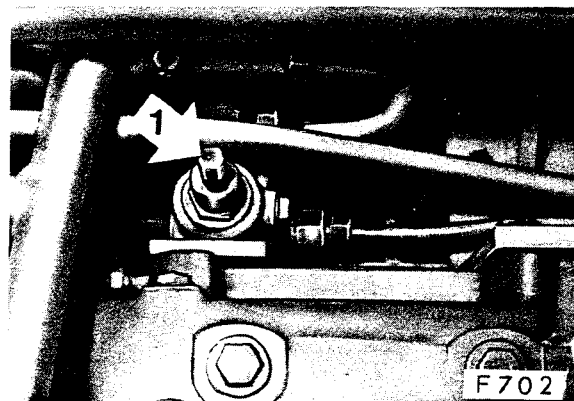
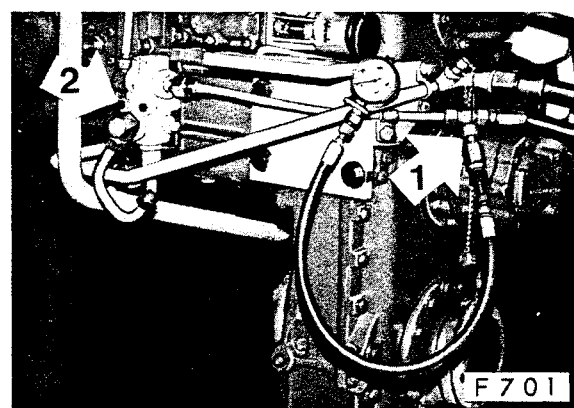
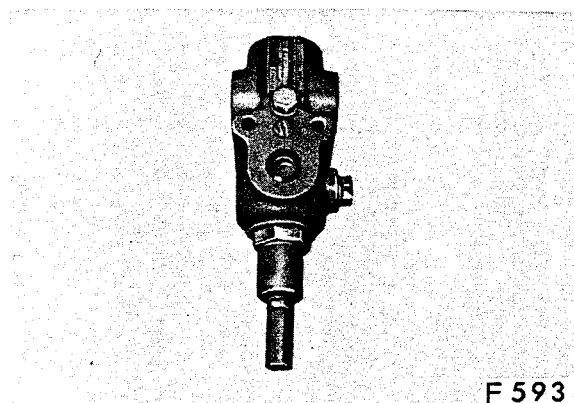

FLOW CAPACITIES - MEASURING

Setting the position of the spool valves in the demand/regulating valve in order to measure the flow capacity of the loader pump and the steering pump

Fig. G 100 (functional drawing)

By displacing the spool valve (17) in the demand valve and the spool valve (4) in the regulating valve by the adjusting screws (A and B), the output of the switch pump (31) will be diverted pressureless into the oil tank (35).

With the spool valves (17 and 4) so set the flow capacities of the loader pump and steering pump can be measured via the connecting points 1 and 2, Fig. G 102 illustrated on page 330.

Measurements:

- Flow capacity of the steering pump at 180 bar (2610 psi)
- Flow capacity of the loader pump at 180 bar (2610 psi)
- Flow capacity of the loader pump at 140 bar (2030 psi)

Setting the position of the spool valves in the demand/regulating valve in order to measure the flow capacity of the switch pump

Fig. G 101 (functional drawing)

The adjusting screw (B) is screwed out so that the spool valve (4) can be pushed back by the spring (5). The adjusting screw (A) remains screwed in as illustrated in the diagram.

The adjusting screw (15) of the regulating valve is screwed in by one turn.

Now the spool valve (4) cannot react thereby preventing the output of the switch pump (31) from flowing back into the oil tank (35). With the spool valves so set the full output of the switch pump will flow into the working (loader) hydraulic circuit (34).

The connecting point (1) for measuring the flow capacities of the loader and switch pump is illustrated in Fig. G 102, page 330. The flow capacities of the loader and switch pumps can only be measured together. The measurement should only be carried out at a pressure of 140 bar (2030 psi). At 180 bar (2610 psi) the engine speed will drop too far.

$$\begin{array}{r}
 \text{Loader pump + switch pump flow capacities (140 bar)} \\
 - \text{Loader pump flow capacity (140 bar)} \\
 \hline
 = \text{Switch pump flow capacity (140 bar)}
 \end{array}$$

After these measurements the regulating valve must be re-adjusted via the adjusting screw (15). (See DEMAND/REGULATING VALVE, testing and adjusting the regulating pressure)

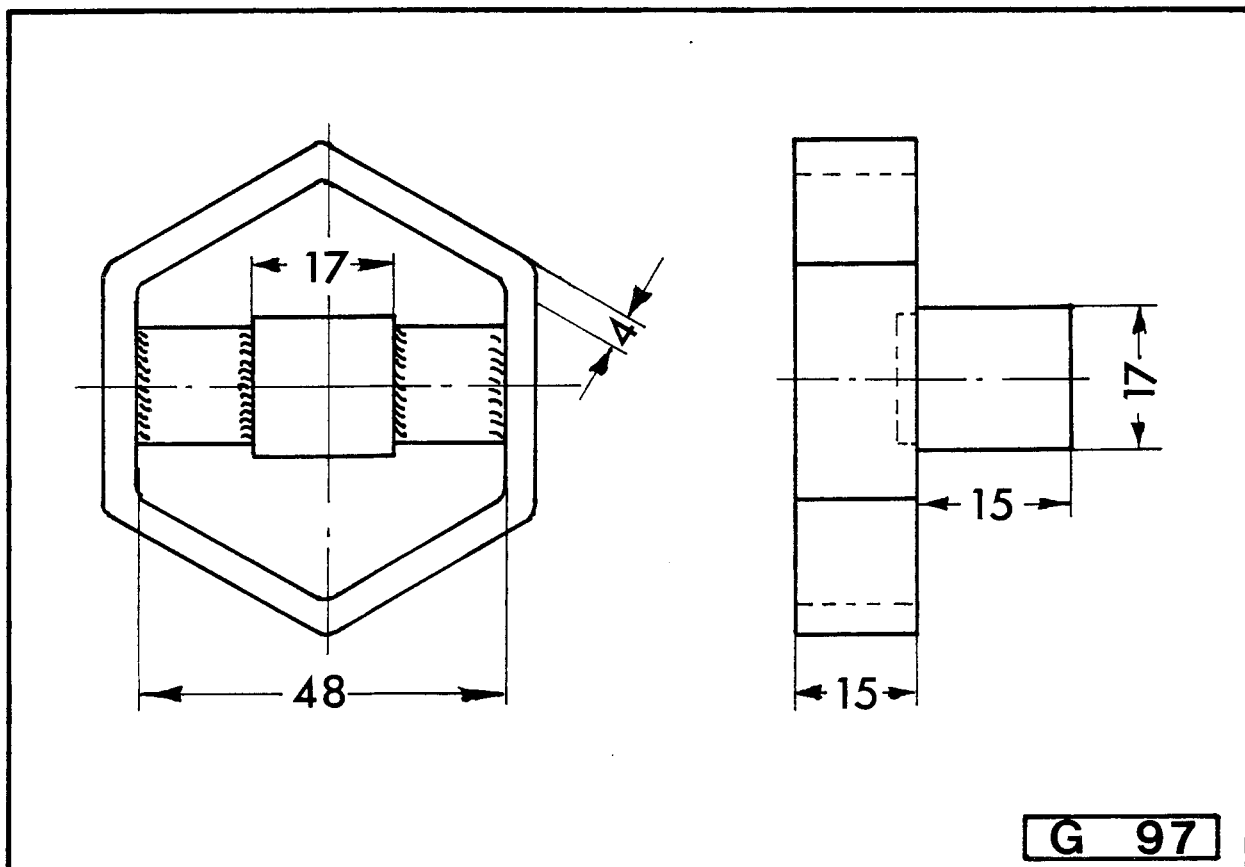
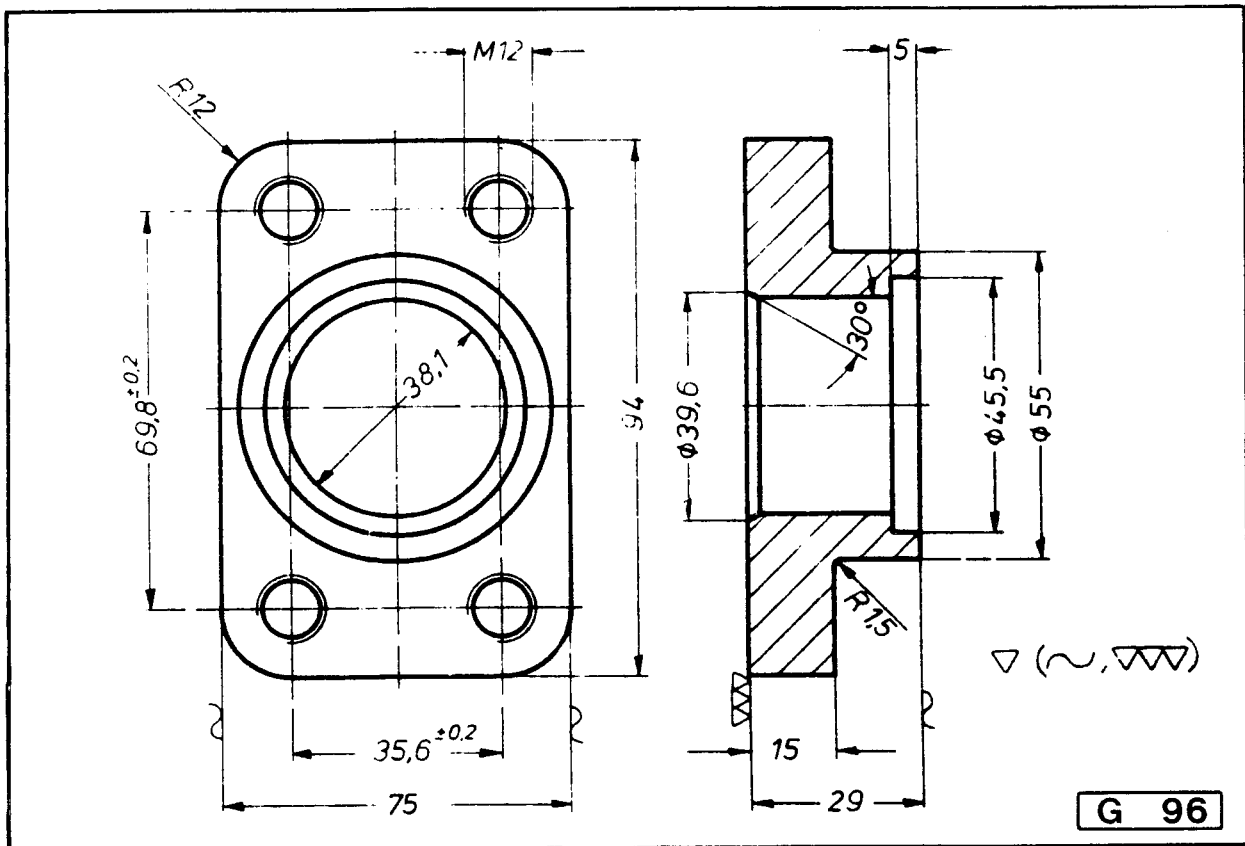

OIL TANK, complete

Oil tank, internal and external fittings

Fig. F 31

		<u>Qty.</u>
1	Closing plug	1
2	Sealing ring	1
3	Nut	31
4	Cover	1
5	Gasket	1
6	Retaining clamps	3
7	<u>Filters, complete</u>	3
8	Filter elements	6
9	<u>Oil tank</u>	1
10	Stud	22
11	Stud	17
+	<u>Inspection glass, complete</u>	1
12	Base plate	1
13	Gaskets	2
14	Plexiglass	1
15	Sealing rings	4
16	Screws	4
16/1	Nuts	4
17	Sealing ring	1
18	Vent screw	1
19	Gasket	1
20	Suction basket	1
21	Closing plug	1
22	Sealing ring	1
23	Spring	1
24	Ball	1
25	Sealing ring	1
26	Drain plug	1

HYDRAULIC PUMP, complete (Switch pump)

Examining the components :

Wash all components in solvent and dry thoroughly.

With a mill file or oil stone, remove all nicks and burrs from the machined surfaces of the end cover and housing.

With an oil stone, remove burrs and light scores from faces and teeth of gears.

Discard pressure thrust plates if scored or show signs of erosion on the gear contact surfaces.

Gears should be replaced as sets, that is:

- a) When the shaft shows pitting or wear at the bearing surfaces in excess of 0,025 mm (0.001 in)
- b) If gears are cracked or badly scored.

All bearings must be replaced, when:

- a) Shaft/gears are renewed
- b) Excessive wear has taken place on needle rollers and cages
- c) Needle rollers are pitted or broken
- d) The needle rollers do not rotate freely and smoothly.

All seals and sealing rings are to be renewed.

Check dowel holes for wear, particularly for elongation, also check the dowels (17) for wear. Renew worn dowels.

Use new spring washers.

CONTROL VALVE, complete
Control valve, external fittings,
removing and refitting

Fig. F 382 and F 383

Screw out the straight threaded connections
(2, 3 and 9).

Screw out the angle threaded connections
(1, 4, 5 and 8).

Screw out the check valve (7).

Replacement follows in the reverse order
as for removal.

To prevent ingress of dirt, all connection
orifices should be plugged.

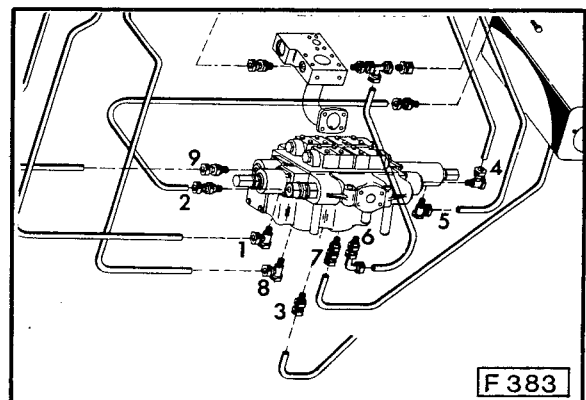
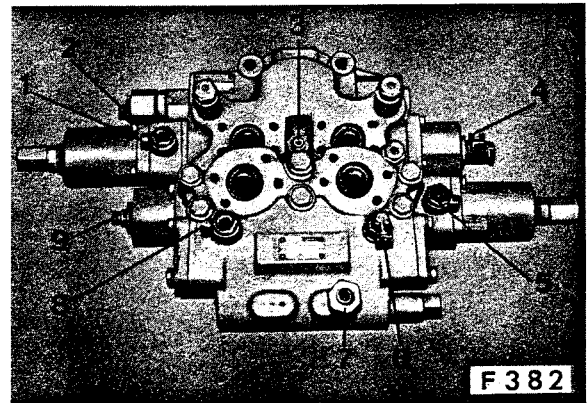

CONTROL VALVE

Pressure valve group, reconditioning

Stripping:

Fig. F 465, F 466 and F 467
Thoroughly clean the float valve and surrounding area.

Screw off the valve cap (13) and remove the sealing ring (3).

Remove the spring (12) and the stop (11).

Remove the spool (6) together with the components (7 to 10) from the housing bore.

Carefully tighten the spool in a vice using soft jaw clamps and unscrew the lock nut (10) and adjusting screw (9).

Take out the valve spring (8) and valve cone (7).

Unscrew the plug screw (2) and remove the 3 sealing rings (3, 4 and 5).

Visual inspection:

Clean all components.
Examine all metal components for wear, distortion and damage. Renew all defective components.

Note: Should the spool surfaces and the bores in the housing be damaged or the valve cone (7) seating in the spool (6) show signs of wear or distortion then the complete float valve must be returned to the manufacturers for reconditioning. Use a replacement assembly.

Re-assembling:

Re-assemble in the reverse order as for removal, paying particular attention to the following points:

- a) Use new sealing rings
- b) Lightly oil all components except threads with hydraulic oil
- c) Secure the closing plug screw (2) using Loctite 69
- d) The spool (6) should not bind in the housing bore.

Finally the pressure valve must be adjusted (see under sub-group 3).

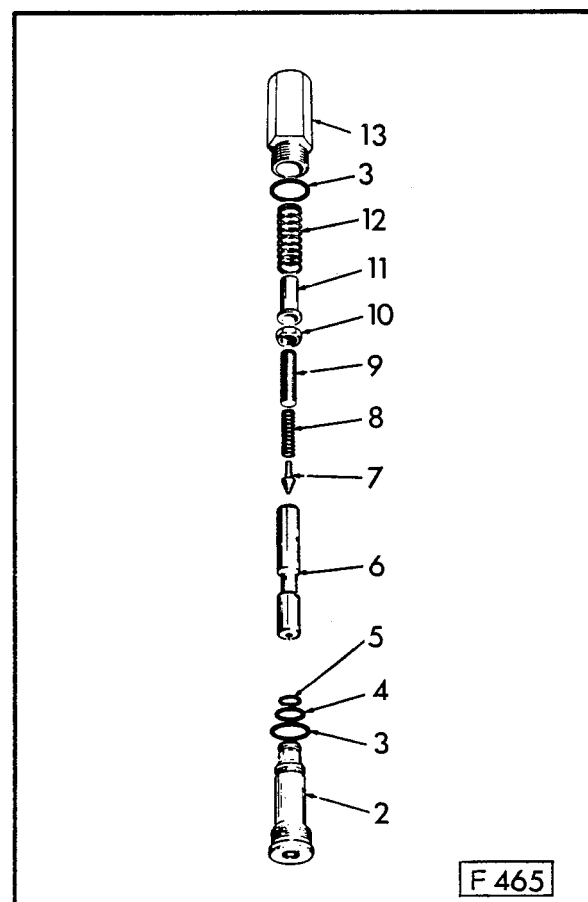
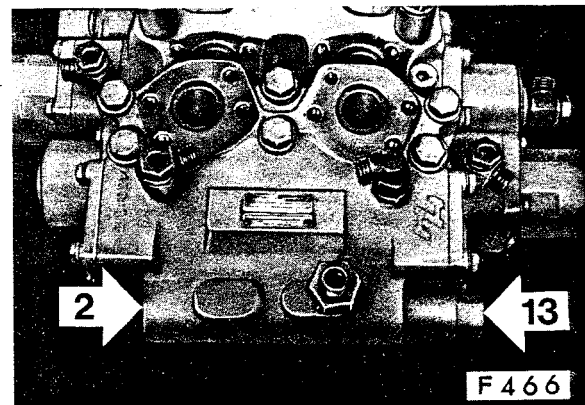

DEMAND/REGULATING VALVE, complete

Fig. F 553

Disconnect the return flow pipe from the demand/regulating valve and remove the pipe ferrule.

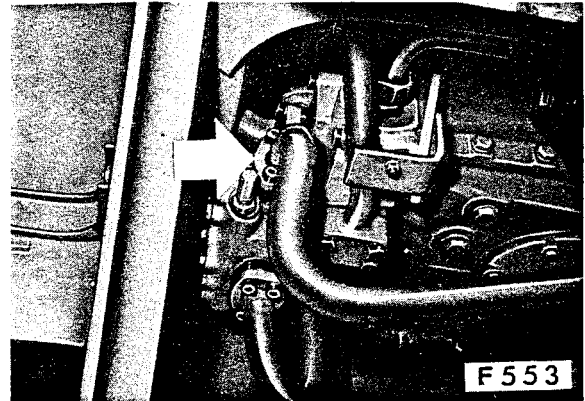

Fig. F 554

Disconnect the demand/regulating valve to steering valve block pressure pipe and remove.

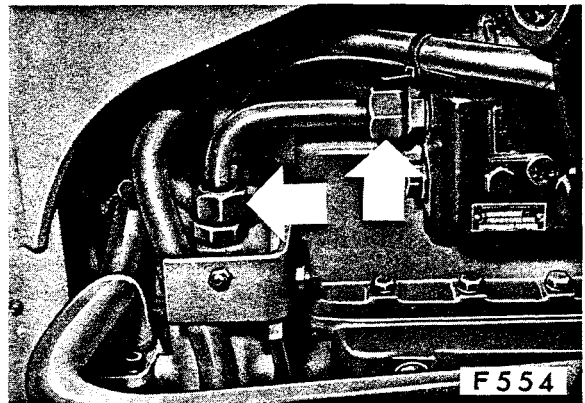

Fig. F 555

Unscrew the hexagon screws and remove together with the spring washers.

Remove the demand/regulating valve.

Replacement follows in the reverse order as for removal.

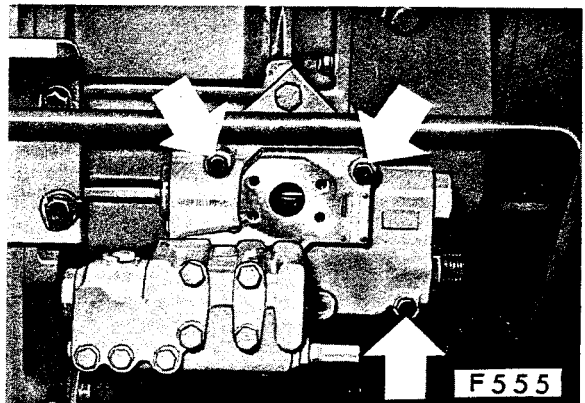

Fig. F 235

Refitting instruction: Use new sealing rings.

Lightly grease the ferrules and sealing rings.

Tighten the screws uniformly and crosswise.

Refill and vent the hydraulic oil tank.

Check for leaks.

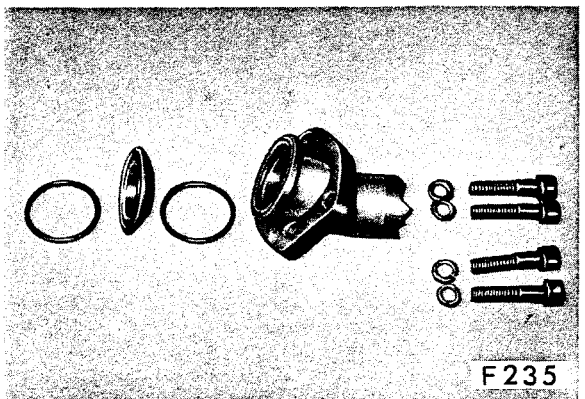

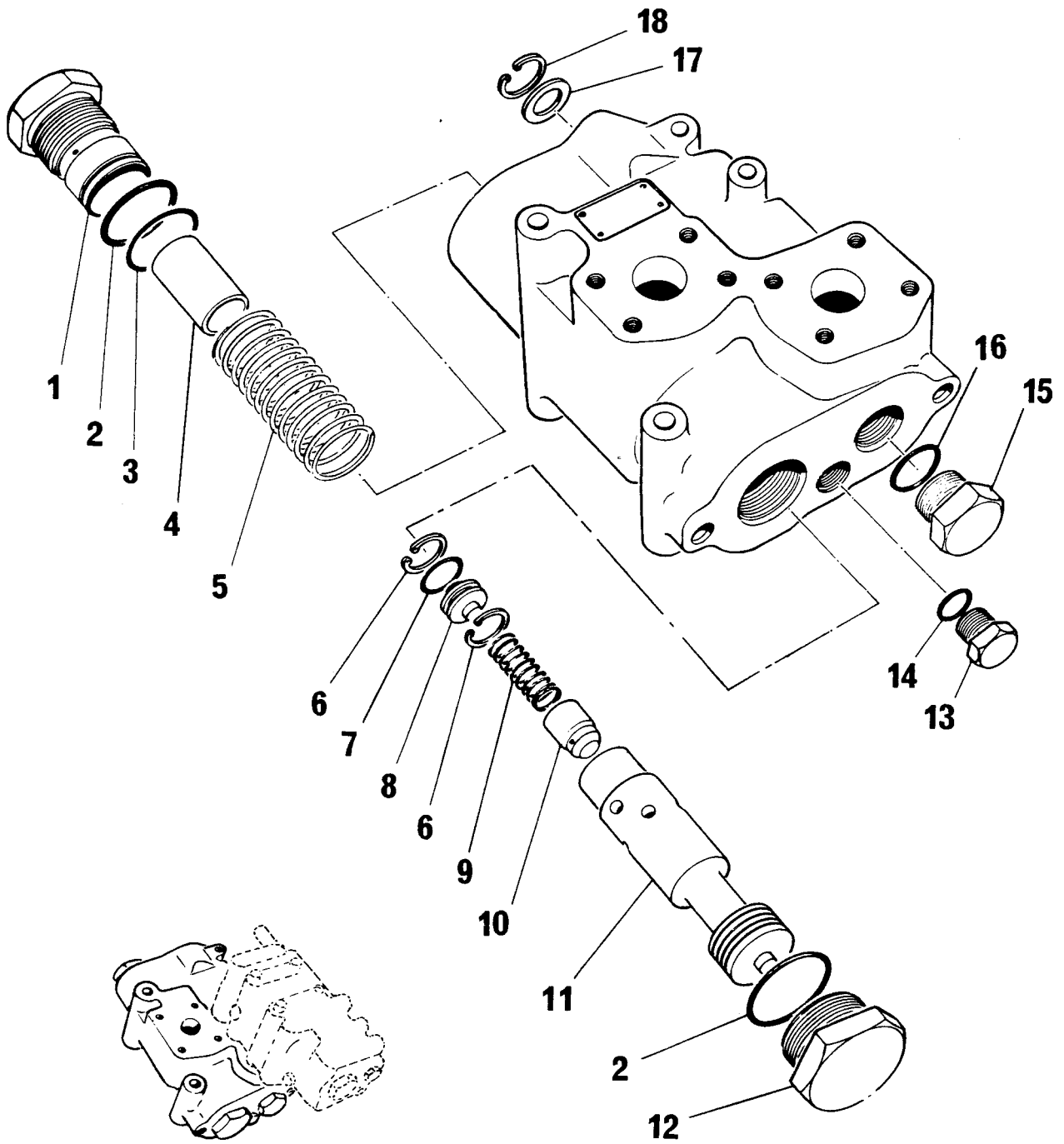

F584

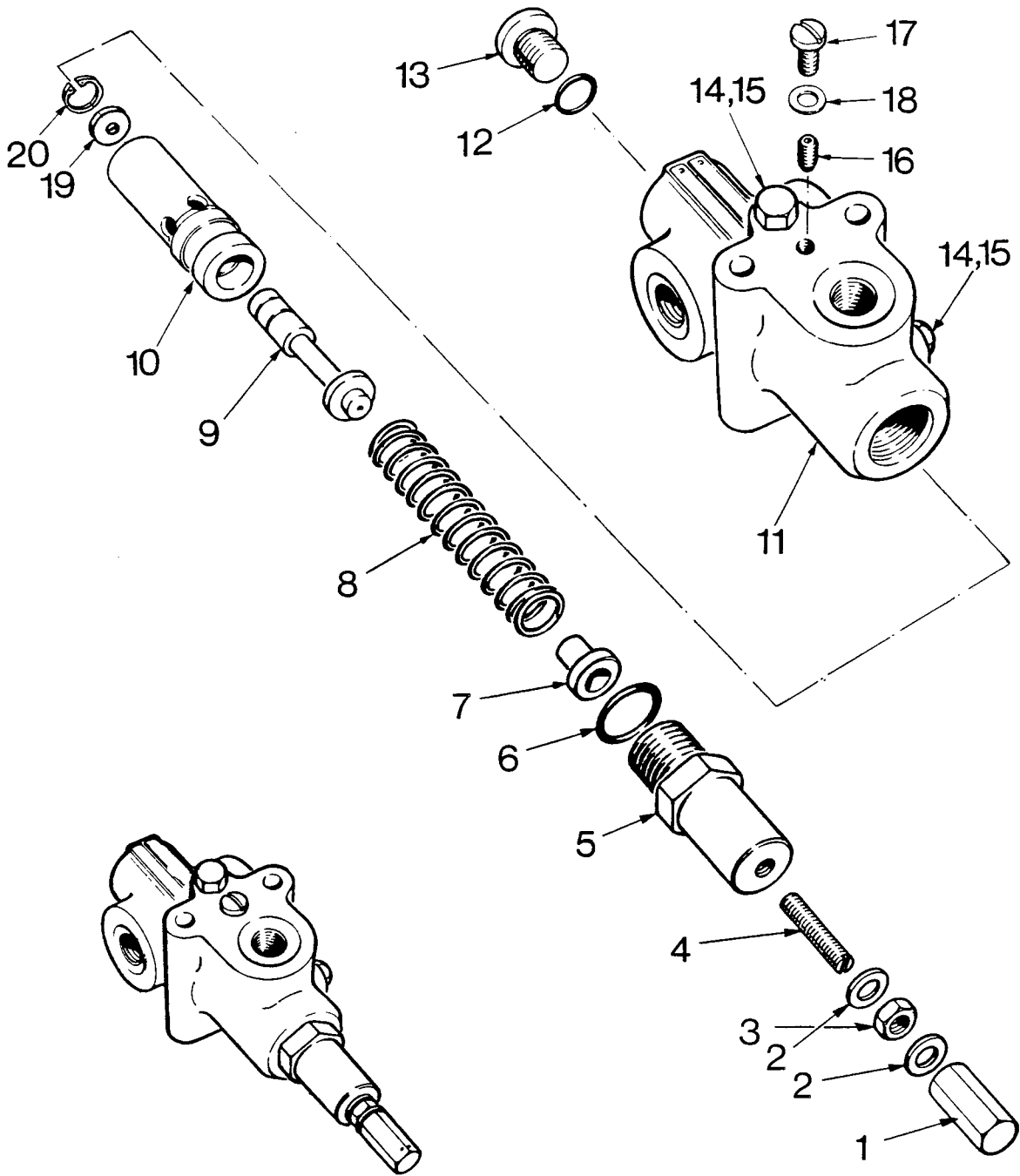

F 597

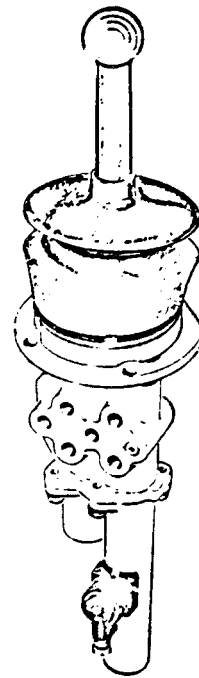
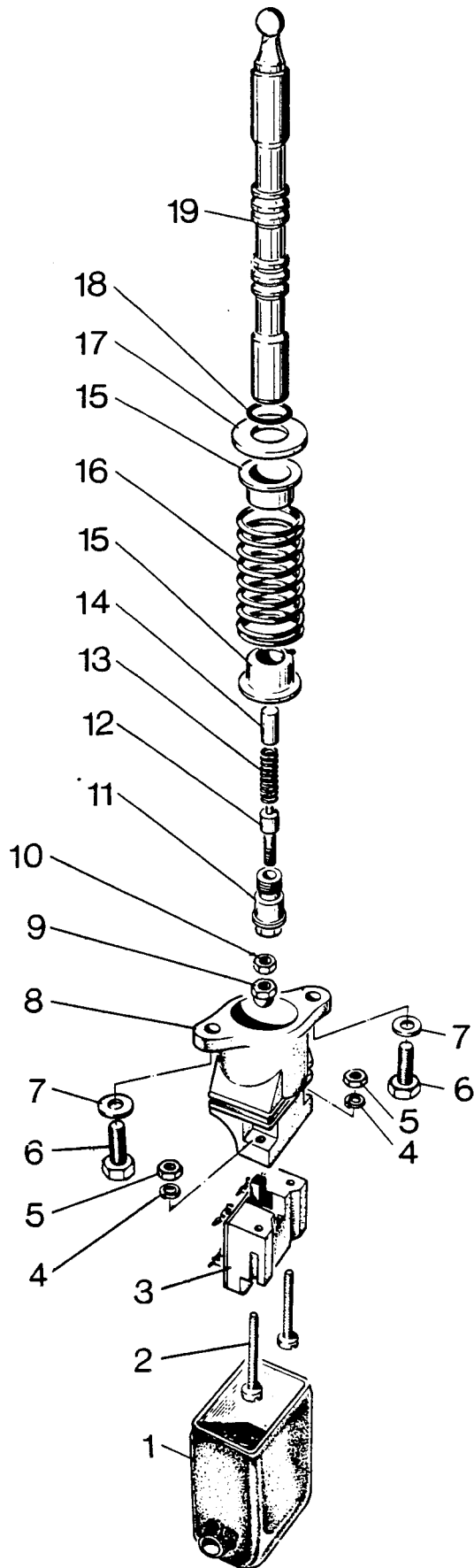

F 600

LIFT CYLINDER, complete

Fig. F 707

Unscrew all 8 hexagonal recessed screws (1) and remove together with the spring washers.

Remove the half flanges (2) and tie up out of the way the two hoses (3).

Refitting instruction: Fit new O-rings in the grooves of the hose flanges.

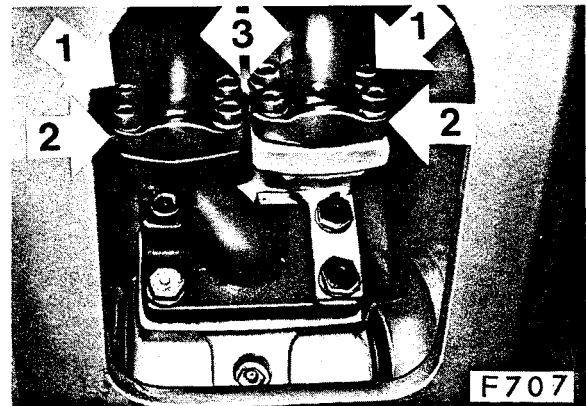

Fig. F 708

Unscrew the hexagonal screws (1).

Remove the retainer plate (2).

Support or suspend the lift cylinder in a sling.

Using the special tool, extract the pivot pin (3) and lift the cylinder from the machine.

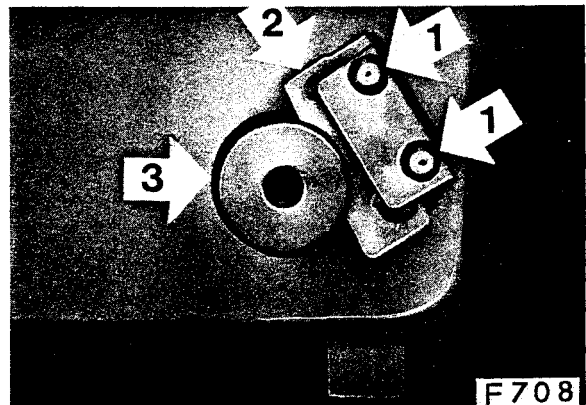

Fig. F 710

Special tool for removing the pivot pin -
Wilbär 5157 B

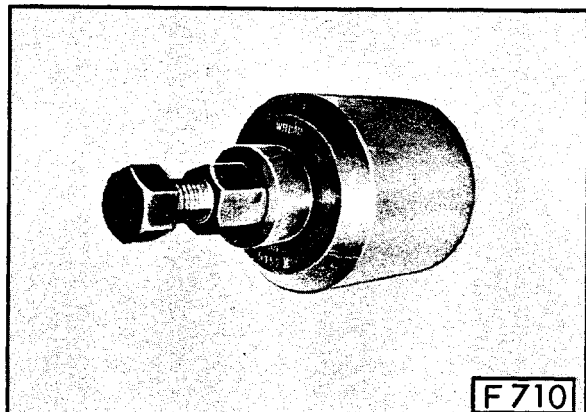

Fig. F 709

Refitting instructions: Use new O-seal rings (1). Before refitting the cylinder, place the O-seal rings over the bearing flanges (2) of the front frame.

After the refitting of the cylinder, the O-seal rings are pushed in between the cylinder and bearing flanges as illustrated in the photograph.

Lightly grease both pivot pins before refitting.

Refitting follows in the reverse order as for removal.

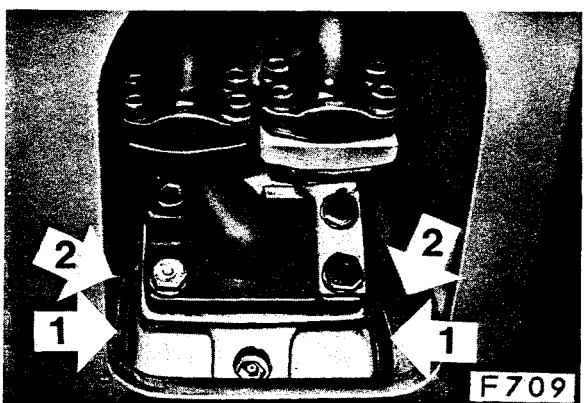

LIFT CYLINDER (Version 1)

Piston seals and guide bands, refitting

Fig. F 752

Note: The piston seal consists of an inner press (back-up)-ring and an outer slide ring (2).

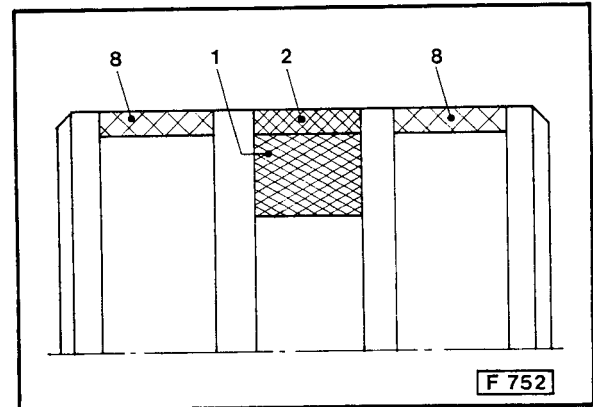

Fig. F 753

Slide the pilot sleeve (3) onto the piston.

Place the press-ring (1) onto the pilot sleeve (3) and with the mandrel (4) push the press-ring into the centre groove of the piston.

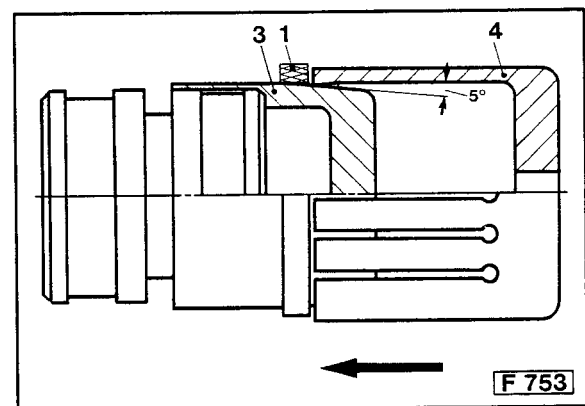

Fig. F 754

Place the slide ring (2) onto the pilot sleeve (3) and with the mandrel (4) push onto the press-ring (1).

Note: To ease the assembly, the slide ring should be pre-heated by immersing in 80° - 90° C (176 - 194° F) warm water.

Fig. F 755

Slide the calibrating sleeve (5) over the piston seal. It should remain on the piston for a certain amount of time in order that the slide ring (2) adapts itself to the sleeve size.

Instead of the calibrating sleeve a piston ring clamp can be used.

Note: In emergency the press-ring and slide-ring can be fitted without use of special tools, but must be carried out with extreme care. Also in this case the slide ring must be left a certain amount of time to adapt to size.

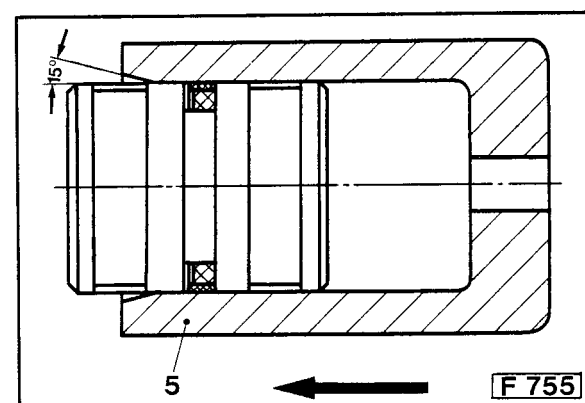
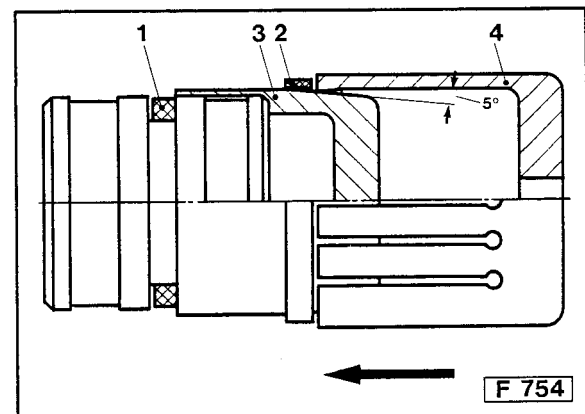

CLICK HERE TO **DOWNLOAD** THE COMPLETE MANUAL

- Thank you very much for reading the preview of the manual.
- You can download the complete manual from: www.heydownloads.com by clicking the link below



- Please note: If there is no response to CLICKING the link, please download this PDF first and then click on it.

CLICK HERE TO **DOWNLOAD** THE COMPLETE MANUAL

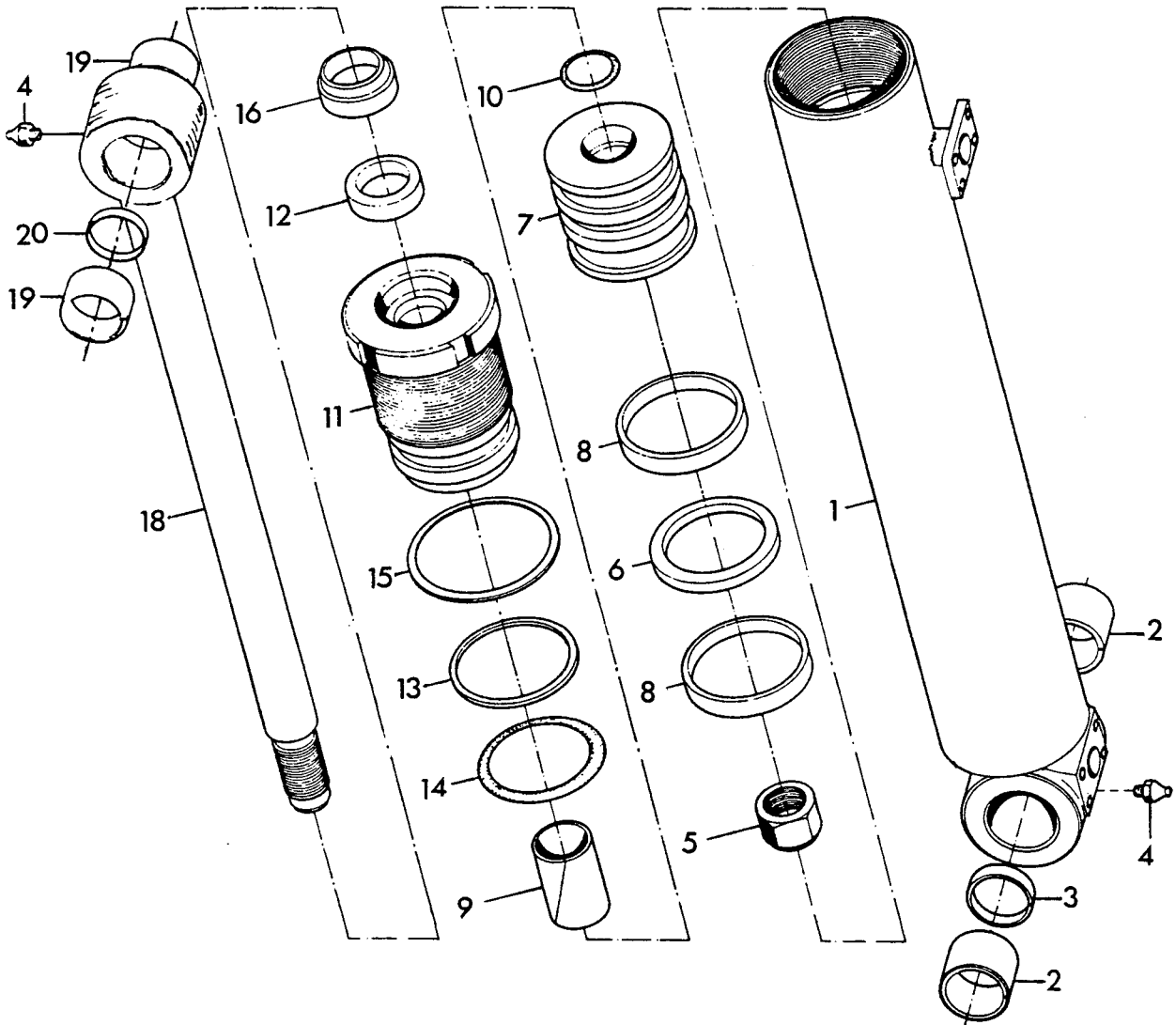

F 759

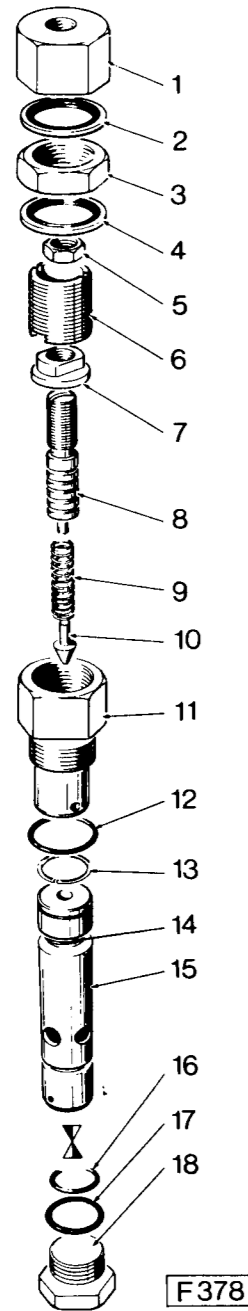

F378

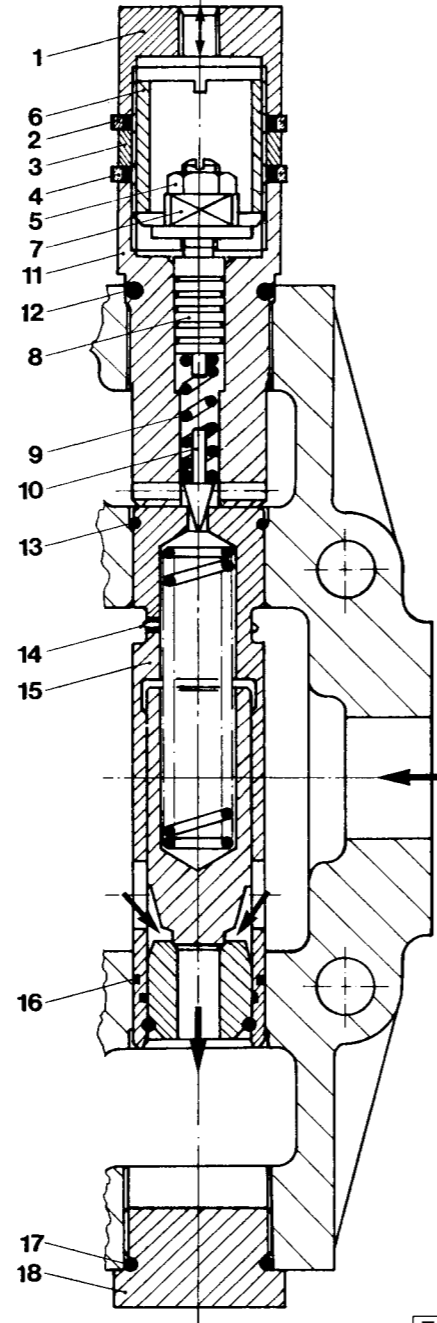

F379

CONTROL VALVE

2-stage pressure relief valve, pressure testing and adjusting

Fig. F 767

Note: With the 2-stage pressure relief valve is the maximum pressures in the working (loader) hydraulics regulated.

Pressures:

- Lifting and lowering = 180 - 185 bar (2610 - 2682 psi)
- Loading and dumping = 120 - 125 bar (1740 - 1812 psi)

The pressures are measured with the engine running at max. speed and a hydraulic oil temperature of 60 - 80° C (140 - 176° F).

Pressure testing:

Fig. F 248

Remove cover plate.
Lift the loader arms and support.

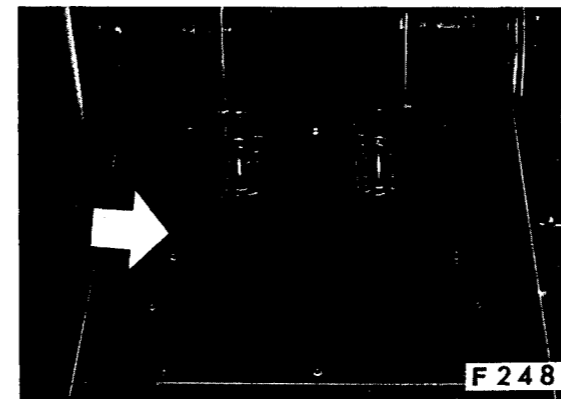
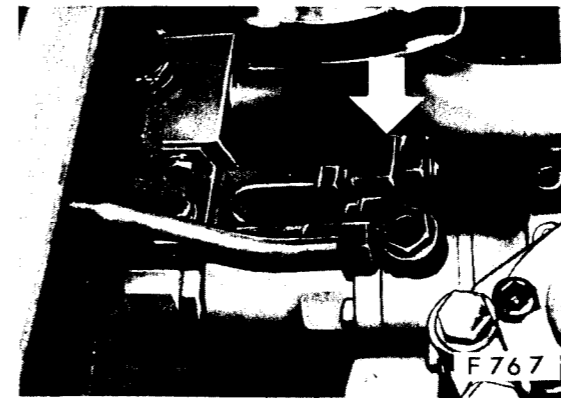
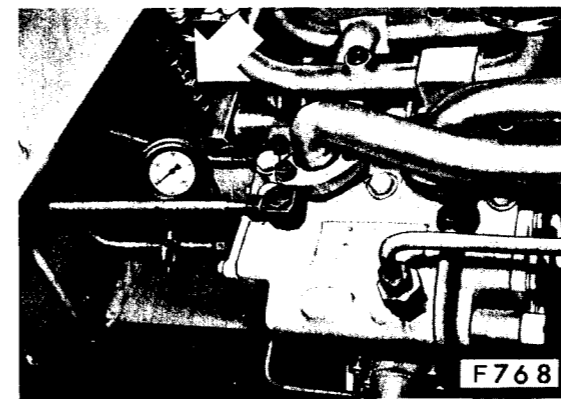

Fig. F 768

Connect a 0 - 400 bar (0 - 5800 psi) pressure gauge.



Note: Position the pressure gauge as far as possible outside of the machine.



Do not work under raised and unsupported loader arms!

Fig. B 162

Start the engine.

Operate the loader arms against limit (crowd) stops (H = lift or S = lower). With the engine running at max. speed the pressure gauge should read 180 - 185 bar (2610 - 2682 psi).

Operate the bucket against limit (crowd) stops (E = load or A = dump). With the engine running at max. speed the pressure gauge should read 120 - 125 bar (1740 - 1812 psi).

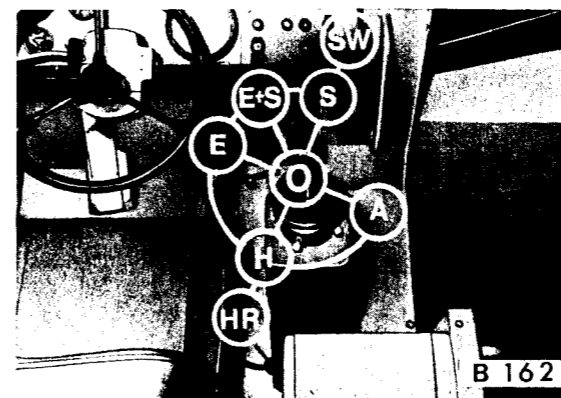

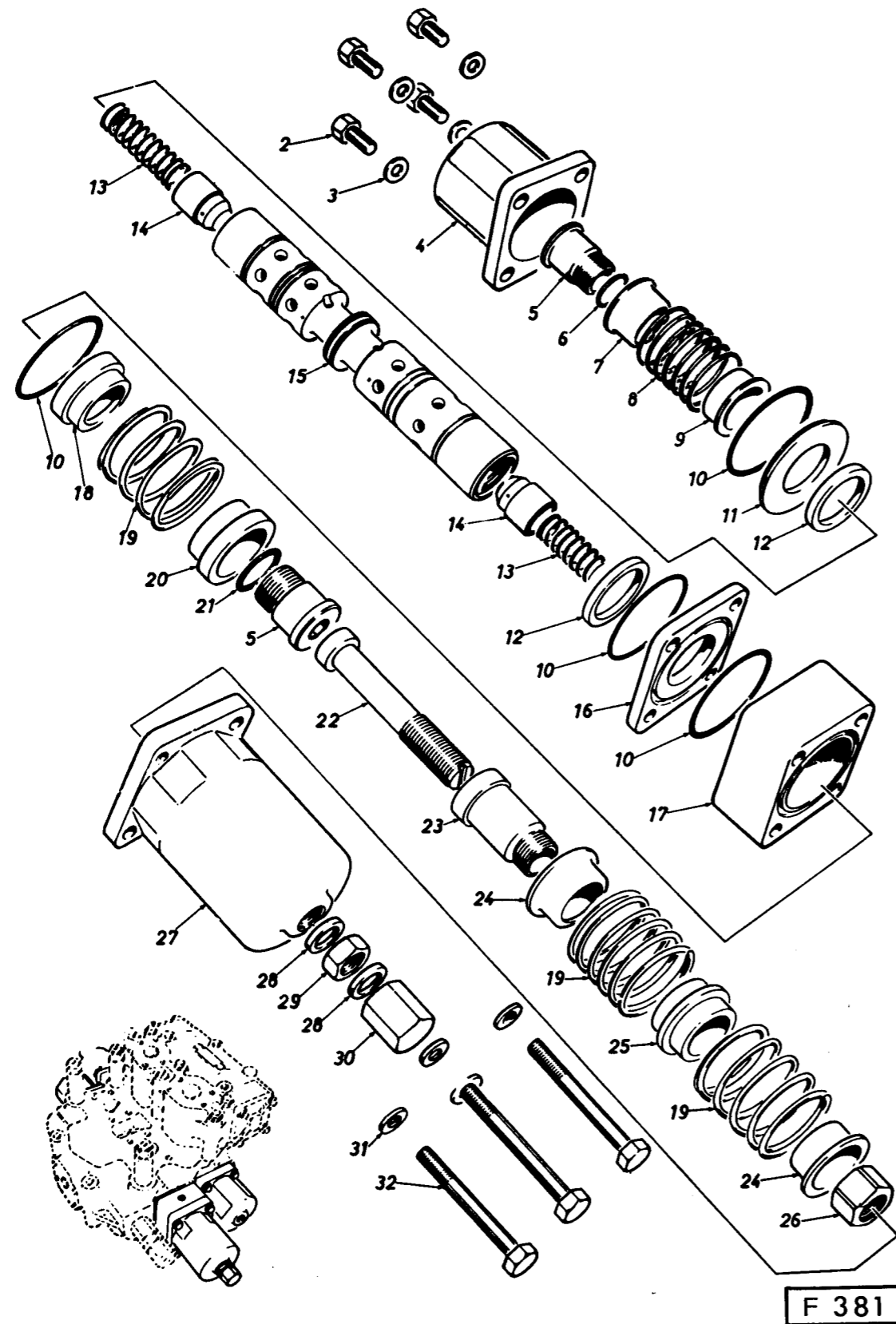

CONTROL VALVE

Spool valves, reconditioningRemoving:

Fig. F 381 and F 556

Thoroughly clean the control valve externally.

Unscrew all 4 bolts (32) and remove the washers (31).

Remove the spring cap (27) complete with the spool valve stroke limiter.

Take off the cover (17) and remove the sealing ring (10) from the groove in the sealing ring carrier (16).

Unscrew all 4 bolts (2) and remove the washers (3).

Remove the spring cap (4) and remove the sealing ring (10).

Screw out both spring bolts (5) from the spool valve (15) using an allen key wrench and remove the sealing rings (6 and 21) from the spring bolts.

Take off the spring collar (7), spring (8), spring collar (9) and seal ring retainer (11).

Remove from the spool valve the spring (13) and the valve cone (14). Mark the valve cone (14) to ensure it is replaced in the same end of the spool valve when re-assembling.

Take off the spring collar (20), spring (19), spring collar (18), seal ring retainer (16) and seal ring (10).

Remove from the other end of the spool valve the spring (13) and valve cone (14). Mark the valve cone to ensure correct re-assembly.

Mark the spool valve (15) to ensure correct re-assembly. Finally remove the spool valve from the housing.

Press out both sealing rings (12).

Note: In cases where, with the control valve in an assembled condition, it is only possible to unscrew one of the two spring bolts (5), the spool valve together with the other spring collars, spring bolt, valve cone and springs which are situated at the opposite end of the removed spring bolt can be removed together as a single unit. Once removed the spool valve can be further stripped by holding the valve carefully in a vice using soft jaw clamps.

The removal procedure for both spool valves is the same. The only difference being is the adjustment of the spool valve stroke limiter.

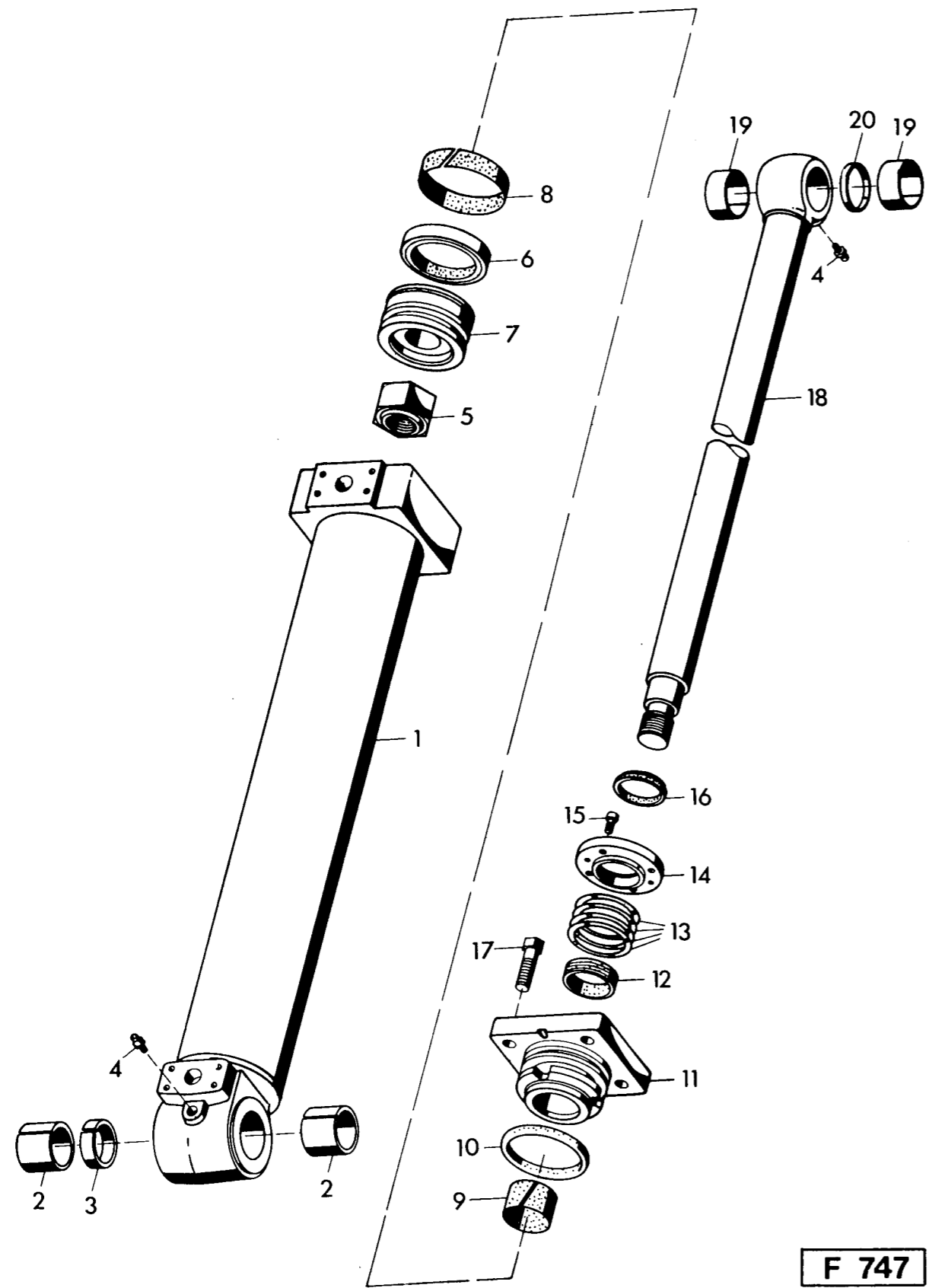

F 747

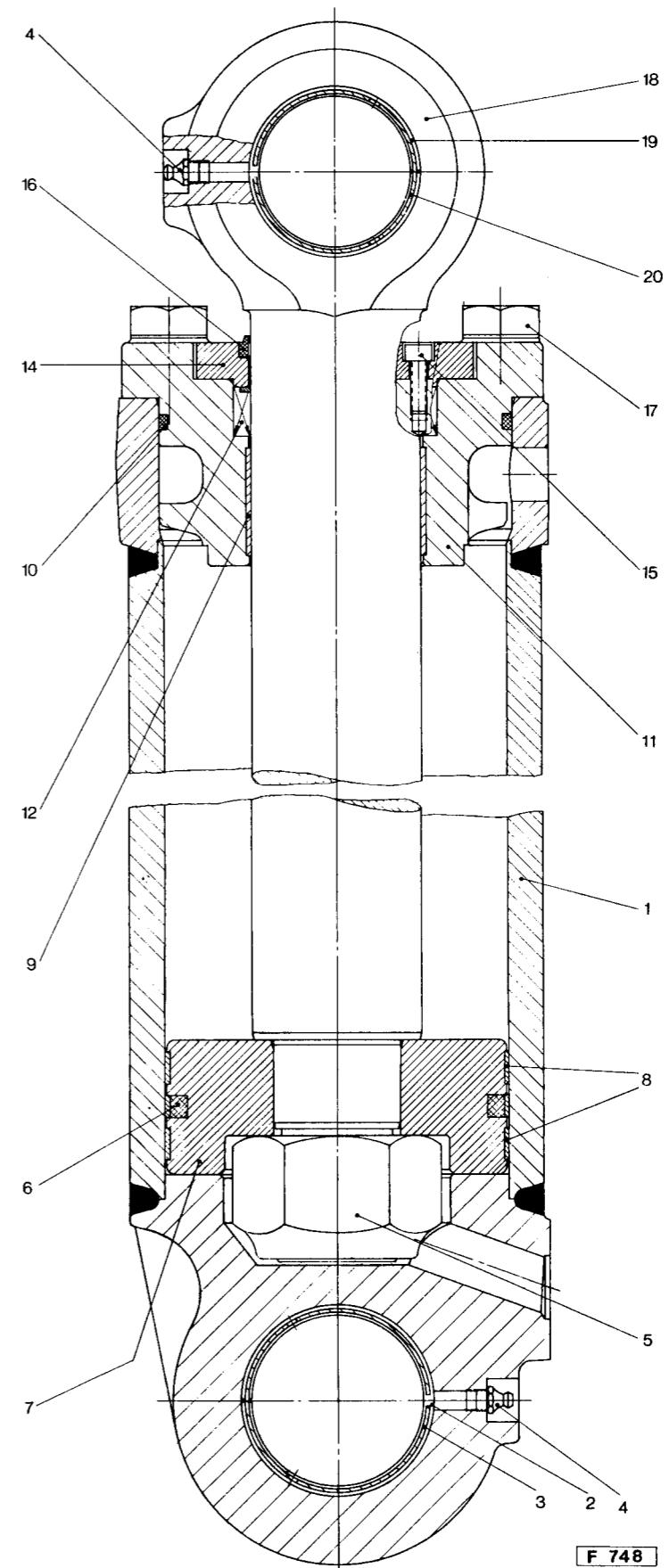

F 748

VORWORT und ERLÄUTERUNGEN

Das vorliegende Handbuch soll den fachkundigen Baumaschinen-Mechaniker bei der Ausführung von Reparaturen und Einstellarbeiten an Baumaschinen unterstützen. Die Arbeitsvorgänge sind so ausführlich beschrieben, daß Demontage und anschließende Montage der Baugruppen ohne Schwierigkeiten erfolgen können.

In den Beschreibungen der Demontage und Montage von Baugruppen stimmen die angezogenen Zahlen mit den Positions-Nummern auf den Bildtafeln überein. Die Bildtafeln sind auf Faltblättern jeweils am Schluß der Demontage- und Montagebeschreibungen angeordnet.

Wenn Sie dieses Reparatur-Handbuch, eventuell zusammen mit anderen Reparatur-Handbüchern für den gleichen Maschinentyp in eine Umschlagmappe mit einem Gruppenregister (Register-Trennblätter aus Karton) einlegen wollen, dann können Sie beides von unserem Ersatzteildienst beziehen.

PREFACE

The Service Manual is intended to assist and instruct workshop personnel to service and repair the machine, and to assist management to determine the facilities required to carry out these activities.

The data and instructions given in this manual apply to all machines unless stated otherwise. Service bulletins will be issued from time to time which may affect procedures given in this manual. Reference to these bulletins should be made before using this manual.

Routine maintenance for the machine is covered by the Operator's Manual issued with each machine.

2500 / 2600

TABELLE DER EMPFOHLENE DICH-, SICHERUNGS- UND SCHMIERMITTEL

Verwendung:	Bezeichnung:
Entfetten der Schrauben	AKTIVATOR T
Sichern der Schrauben	LOCTITE Nr. 270
Einsetzen von Zylinderstiften	LOCTITE Nr. 270
Kleben von O-Ringen	ISAMET A
Abdichten der Gehäusestirnflächen etc.	SIGMA
Einsetzen von Dichtringen	LEAD SEAL Nr. 2
Fett zur Nadellagermontage	VASELINE
Fett zur Dichtringmontage	} Fettqualität siehe ZF-Schmierstoffliste TE -ML 05!
Fett für Dauerfettpackungen	

Hinweis:
 Beim Sichern der Schrauben und Zylinderstifte in Sackbohrungen ist das Sicherungsmittel auf dem Schraubengewinde bzw. dem Zylinderstift und in der Bohrung aufzubringen!

TABLE OF RECOMMENDED SEALING AND LOCKING COMPOUNDS AND LUBRICANTS

Application:	Denomination of the agent:
Degreasing of screws	AKTIVATOR T
Locking of screws	LOCTITE No. 270
Installation of dowels	LOCTITE No. 270
Sticking of O-rings	ISAMET A
Sealing of the housing faces etc.	SIGMA
Installation of oil seals	LEAD SEAL No. 2
Grease for the reassembly of needle roller bearings	VASELINE
Grease for the reassembly of oil seals	} Grease properties see ZF-List of lubricants TE-ML 05!
Grease for permanent grease packings	

Note:
 When locking screws and dowels in blind holes, the locking compound must be applied to the threads of the screw or the dowel resp. as well as to the bore!

ANLEITUNG für TELLERRADVERSCHRAUBUNG an ZF-ACHSEINSÄTZEN (Bild L 1)

Hinweise:

Steht bei Reparaturen von ZF-Achseinsätzen keine geeignete Presse für die Vernietung von Tellerrädern auf die Differentialkörbe zur Verfügung, bietet sich die Möglichkeit der Tellerradverschraubung an.

Die Verschraubung kann ohne Nacharbeit von Teilen vorgenommen werden.

Um einen einwandfreien Reibschluß zu gewährleisten, ist auf eine saubere, fettfreie Auflagefläche zwischen Tellerrad und Differentialkorb zu achten

Achseinsatztypen	Ersatzteil-Nummer
Achseinsatz "B" Skizze 1	3 = M 10 x 1 - 10.9, ZF-Teil-Nr. 0736 101 026 4 = M 10 x 1 - 10 DIN 935 (Anziehdrehmoment $M_A = 73 \text{ Nm}$) 5 = 2,5 x 20 DIN 94
Achseinsatz "D" Skizze 2	3 = 3245 003 M1 4 = 3008 438 X1 (Anziehdrehmoment $M_A = 190 \text{ Nm}$) 5 = entfällt, dafür mit LOCTITE gesichert
Achseinsatz "D" Skizze 3	3 = 3075 656 M1 4 = 3008 439 X1 (Anziehdrehmoment $M_A = 125 \text{ Nm}$) 5 = 1442 994 X1 6 = 3245 005 M1 (Einbau zum Teil nicht erforderlich)
Achseinsatz "H" Skizze 4	3 = 3075 656 M1 4 = 3008 439 X1 (Anziehdrehmoment $M_A = 125 \text{ Nm}$) 5 = 1442 994 X1
Achseinsatz "L" Skizze 5	3 = 3235 060 M1 4 = 3008 440 X1 (Anziehdrehmoment $M_A = 295 \text{ Nm}^*$) 5 = 390 448 X1
Achseinsatz "R"	3 = 3235 063 M1 4 = 3008 440 X1 (Anziehdrehmoment $M_A = 295 \text{ Nm}^*$) 5 = 390 448 X1

Hinweise für Anziehdrehmomente *):

Die angeführten Werte können sich wegen der radialen Lage der Kronenmutter (4) geringfügig ändern.

Wo ein Fehler von etwa 2% zulässig ist, rechnet man: 1 kpm = 10 Nm!

Loosen hex. head screws and remove lock plate.

Loosen both adjusting nuts 43.

Loosen hex. head screws and remove both bearing caps.

Note: Mark bearing cap and axle carrier -
see arrow!

Screw off both adjusting nuts.

Lift differential assembly out of the axle carrier (■).

MONTAGE – zu TAFEL 4:

Achtung – Hinweise beachten!

Wenn Tellerrad oder Antriebsritzel beschädigt sind, müssen beide Teile erneuert werden!

Bei Neueinbau eines kompletten Tellerradsatzes beachten, daß Tellerrad und Antriebsritzel gleiche Paarungsnummern haben!

Bei Austausch eines kompletten Tellerradsatzes oder Achstriebgehäuses – Skizzen A + B beachten!

Erwärmten Innenring des Kegelrollenlagers 15 (ca. 90° C) über den Schaft des Antriebsritzels führen und zur Anlage bringen – siehe Pfeil!

Hinweis: Auf einwandfreie Anlage achten!

Vollrollenlager 39 erwärmen (ca. 90° C) und am Bund des Antriebsritzels zur Anlage bringen. Mit Sicherungsring 40 fixieren.

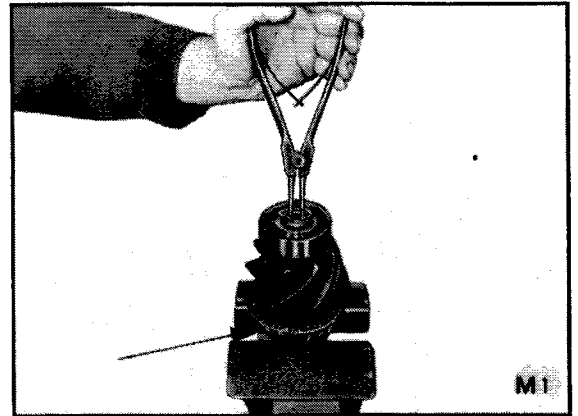

Beide Außenringe der Kegelrollenlager 12 + 14 in der Lagerbuchse 13 zur Anlage bringen (■).

Hinweis: Auf einwandfreie Anlage achten!

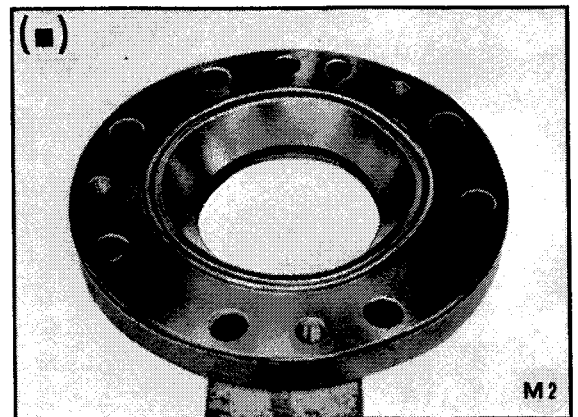

Install shaft seal 9 firmly into the sealing cap 8 until contact is obtained.

Note: Use driver (■)!

Cover outer diameter with sealing compound!

Sealing lip towards the face of the bearing bush!

Cover face of bearing bush with sealing compound.

Lay sealing cap upon bearing bush (pay attention to the marking) and fasten it provisionally - see arrow!

Heat drive flange 4 (about 90° C).

Slide drive flange over the splines of the drive pinion until contact is obtained.

Note: Fill cavity between sealing lip and dust lip of the shaft seal with grease!

Replace washer 3 and install castle nut.

Fasten pre-assembled drive pinion at the drive flange in the special device (■).

Tighten castle nut by means of torque spanner.

Note: Torque limit of the castle nut for ZF-Differential carrier - type

D = 350 Nm

H = 350 Nm

L = 600 Nm

R = 900 Nm

S = 1200 Nm

CAUTION: Standard, however, is the rolling resistance of the DRIVE PINION BEARING - see Fig. M 13 !

Abwechselnd 1 Außenlamelle 62 – siehe Bild M 27 – und 1 Innenlamelle 63 – siehe Bild M 28 – einlegen.

Hinweis: Anzahl und Lamellenpaarung ist von der Höhe des vorgeschriebenen Sperrwertes abhängig!

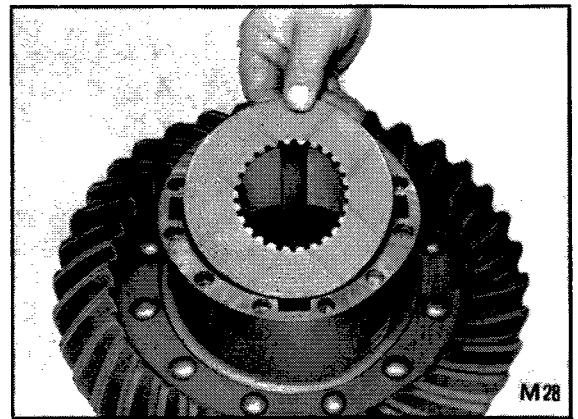
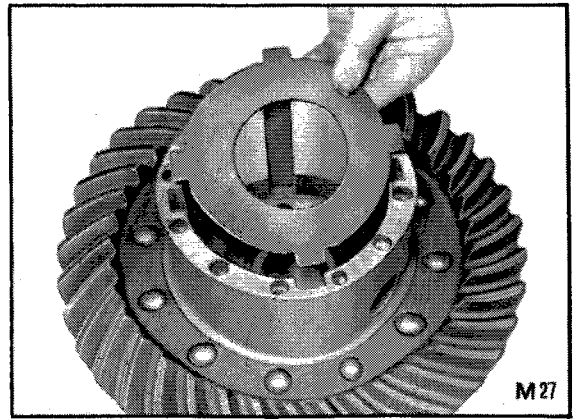

Druckring 64 einsetzen

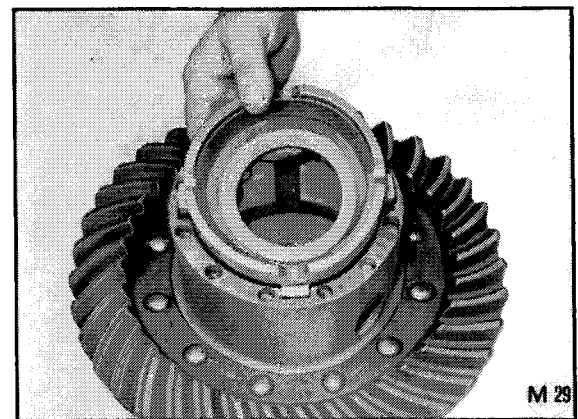

Achskegelrad 65 einsetzen, dabei achten, daß Innenlamellen aufgefädelt werden.

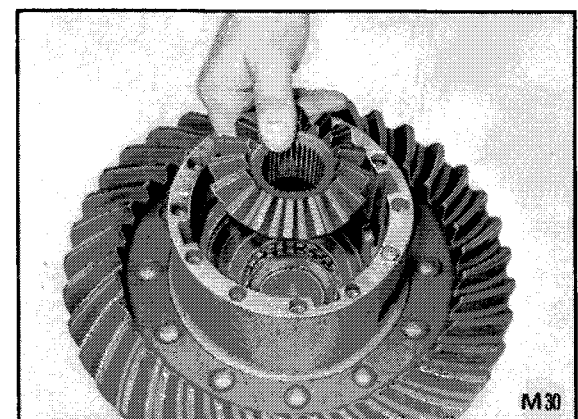

Note: The illustrations M 44 - M 46 are not corresponding with the differential Version with plates, the steps, however, are the same!

Measure BACKLASH:

Note: Install dial indicator - at a right angle - on the outer diameter of the tooth flank/crown wheel.

Measure actual backlash, pay attention that the drive pinion does not move when the crown wheel is moved forwards and backwards!

Backlash should be 0,30 mm, resp. pay attention to the value etched upon the outer diameter of the crown wheel!

Measure RUNOUT of the crown wheel:

Note: Install dial indicator - at a right angle - on the ground side of the crown wheel back.

Rotate the crown wheel carefully and read the runout on the dial indicator.

Admitted runout max. 0,08 mm!

Check CONTACT PATTERN on the crown wheel:

Note: Cover some of the tooth flanks of the crown wheel with oiled red lead and take the contact pattern by rolling the drive pinion.

The found contact pattern should be similar to the EXAMPLES OF CONTACT PATTERNS shown under Section A!

Secure hex. head screws of the bearing cap fastening (see arrow 1) and both adjusting nuts against getting loose - see arrow 2!

Note: The locking components for the adjusting nuts are different according to the differential carrier type!

Press shaft 83 out of the planetary carrier and remove the released components 87-90.

Caution: For the planetary gear bearing/
Version (a) pay attention to the
needles 89 installed in the
planetary gears!

Squeeze circlip 78 out of the stub shaft groove.

Remove sun gear 77 and thrust washer 76.

Unlock and loosen both slotted nuts 75+73 (■).

MONTAGE – zu TAFEL 2 / mit TROMMELBREMSE:
Siehe Seite 123

Ölfangblech 37 über den Bund des Nabenträgers setzen und zur Anlage bringen – siehe Pfeil!

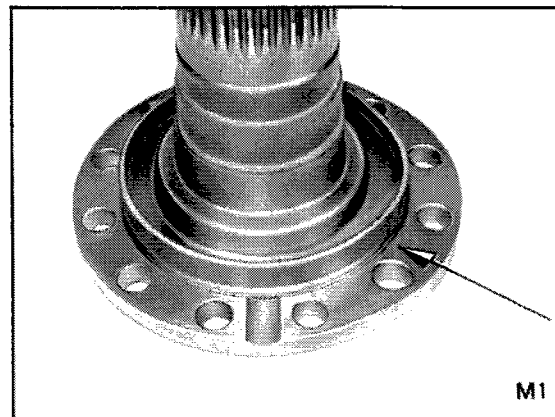

Nabenträger 30 an der Achsbrücke zur Anlage bringen.
Hinweise: Flanschfläche von Achsbrücke mit Dichtmittel versehen!
Einbaulage von Aussparung beachten – siehe Pfeil!

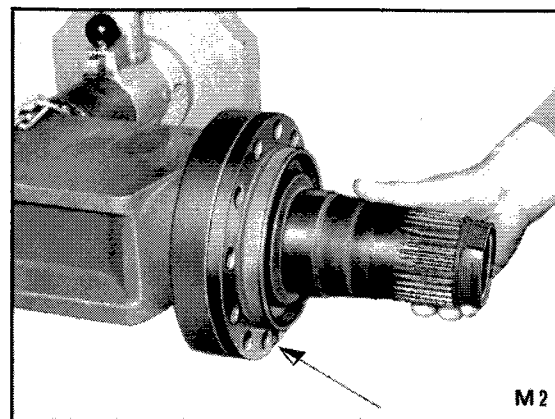

Bremsträgerplatte 31 an der Stirnseite/Nabenträger zur Anlage bringen und befestigen.

Hinweise: Einbaulage bzw. Markierung beachten!
Anziehdrehmoment für Mutter M 18 x 1,5 (10.9) beträgt 460 Nm!

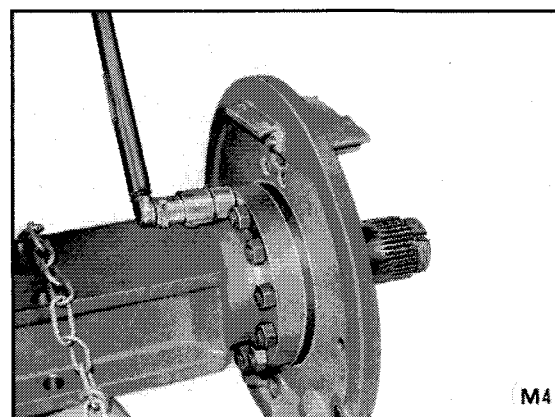
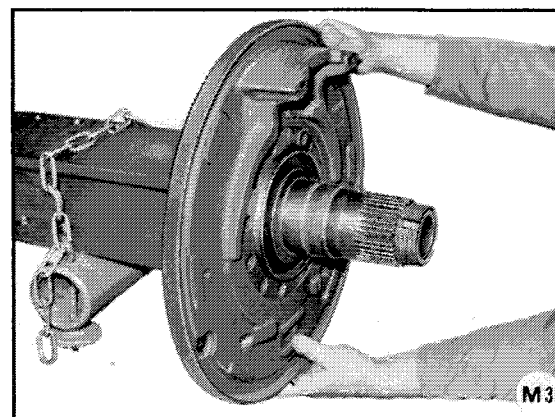

Slide complete gear ring carrier over the splines of the hub carrier and insert it into the hub.

Slide stub shaft carefully through the bore of the axle housing until the splines of the stub shaft have been received in the differential.

Note: The splines of the stub shaft may not become jammed in the differential!

Install the inner slotted nut 73 - see Fig. M 22 and tighten it (■) - see Fig. M 23.

Note: Spray Molykote upon the threads of the hub carrier and upon threads and contact area of the inner slotted nut!

Pay attention that both slotted nuts can be turned by hand on the hub carrier!

Chamfered face of the inner slotted nut towards the outside - see arrow!

Torque limits for the inner slotted nut see Table -

"ADJUSTMENT VALUES FOR WHEEL BEARINGS (HUBS)"

Replace lock plate 74, install outer slotted nut 75 and tight it also (■).

Note: Chamfered side of slotted nut towards the inside!

Axiales Ausmitteln der Steckwelle – siehe dazu auch als Ergänzung:

ANLEITUNG für "Axiales Ausmitteln der Gelenkwelle (Steckwelle)" im Register A!

In die zentrale Bohrung des Planetenträgers Distanzscheibe 80 und Anschlagbolzen 79 einsetzen.

Hinweis: Distanzscheibe und Anschlagbolzen mit Dichtmittel versehen!

Dicke der Distanzscheibe ermitteln:

Maß von Stirnfläche/Planetenträger bis zum eingesetzten Anschlagbolzen feststellen,

z.B: Meßleiste + Endmaß	100,00 mm
- abgelesener Wert	85,10 mm
<hr/>	
Maß I	14,90 mm
<hr/>	

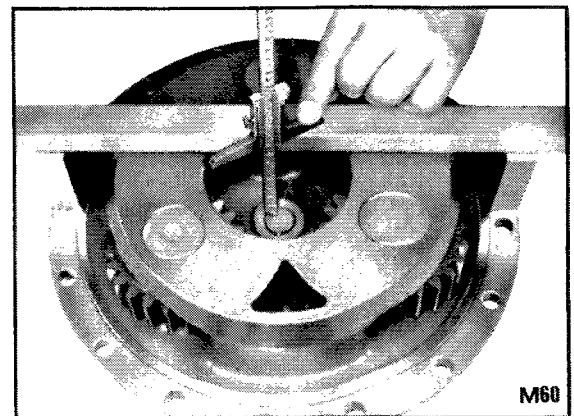

Steckwelle soweit einschieben, bis Sonnenrad an der Anlaufscheibe einwandfrei anliegt!

Maß von Stirnfläche/Nabe bis zur Stirnfläche/Steckwelle feststellen,

z.B.: Meßleiste + Endmaß	100,00 mm
- abgelesener Wert	85,40 mm
<hr/>	
Maß II	14,60 mm
<hr/>	

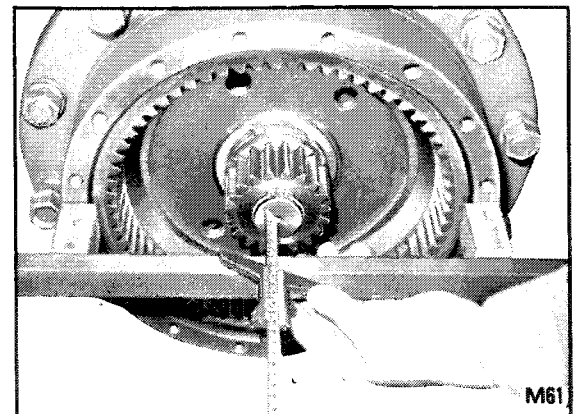

Rechnungsbeispiel:

Maß I	14,90 mm
- Maß II	14,60 mm
<hr/>	
Differenz	0,30 mm
<hr/>	

Hinweise: Erforderliches Axialspiel bei allen Starrachstypen 0,30 - 0,50 mm!

Korrigiert wird dieser Wert durch den Einbau entsprechend dicker Distanzscheiben 80!

Diese Scheiben sind in den Stärken 0,30/0,50/1,00 und 3,00 mm vorhanden.

Press shafts 83 out of the planetary carrier
and remove released components 87-90.

Caution: For planetary pinion bearings/Version
(A), pay attention to the needles 89
installed in the planetary pinions!

Squeeze circlip 78 out of the stub shaft
groove.

Remove sun gear 77 and thrust washer 76.

MONTAGE zu Tafel 2/mit SCHEIBENBREMSE

Kompletten Achseinsatz vor Beginn der Montage in die Achsbrücke einsetzen.

Hinweise: Einbaulage von Achseinsatz beachten – siehe Pfeile!
2 Stiftschrauben (■) in Achsbrücke eindrehen – siehe Pfeile 1!
Flanschfläche von Achsbrücke mit Dichtmittel bestreichen!

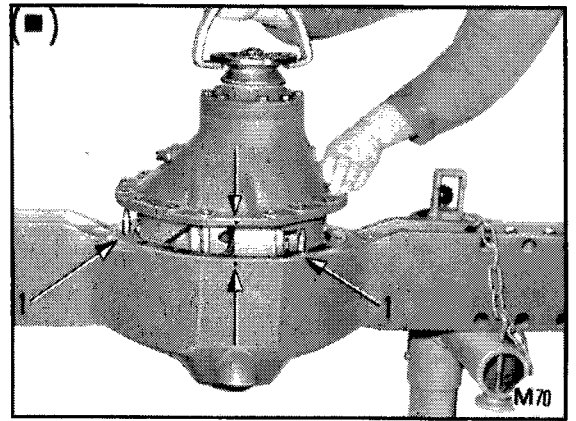

Mit Sechskantschrauben den Achseinsatz befestigen.

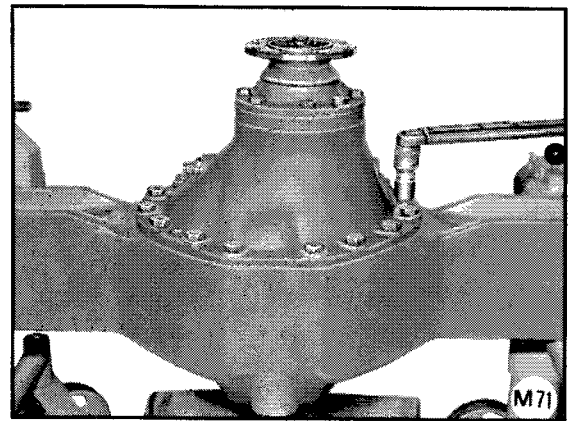

Achsbrücke OHNE BREMSTRÄGER – siehe Bild M 72 – M 74

Hinweis: Bei dieser Ausführung werden die Bremssättel direkt an der Achsbrücke befestigt!

Nabenträger 30 an der Achsbrücke zur Anlage bringen und mit Zylinderschrauben befestigen.

Hinweise: Flanschfläche von Achsbrücke mit Dichtmittel versehen!
Einbaulage von Aussparung beachten – siehe Pfeil/Bild M 73!
Anziehdrehmoment für M 18 x 1,5 (10.9) beträgt 460 Nm!

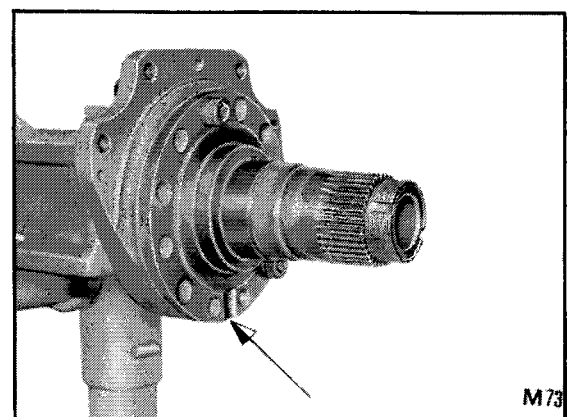
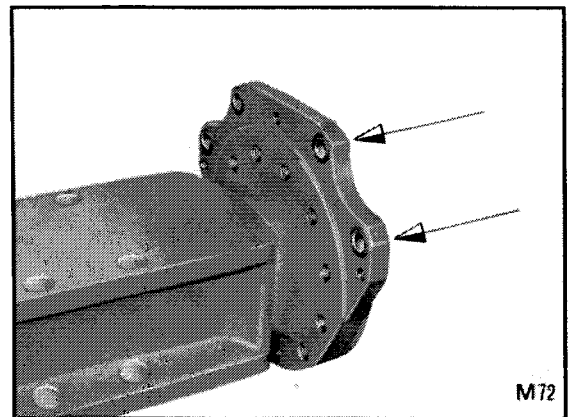

Determine ROLLING RESISTANCE OF THE HUB:

Wrap suitable string around the hub 38 and check rolling resistance by means of commercial pound scale.

Note: The rolling resistance is -

AP-5 ...	-	6,5	-	9,5	Nm (*)
AP-7 ...	-	9,0	-	14,0	Nm (*)
AP-9 ...	-	12,0	-	18,0	Nm (*)
AP-11 ..	-	13,0	-	19,0	Nm (*)
AP-15 ..	-	14,0	-	20,0	Nm (*)
AP-20 ..	-	14,0	-	20,0	Nm (*)
AP-25 ..	-	35,0	-	40,0	Nm (*)
AP-30 ..	-	35,0	-	40,0	Nm (*)

Note ref. (*): For run-in bearings reduce this value for 50%.

Formula for the calculation of the rolling resistance (T):

$$T = F \times R$$

T = Moment of force in Nm (Newtonmeter);

F = Traction power in N (Newton);

R = Radius in m (meter);

Lock both slotted nuts by means of lock plate (see arrows/Fig. M 91)!

Place thrust washer 76 with noses ahead (see arrow) against the face/hub carrier.

Slide sun gear 77 over universal shaft splines and fix by means of circlip 78.

BREMSSATTEL befestigen:

(Brems-Ausführung „B“/Tafel 2 a).

Kompletten Bremssattel vorsichtig über die Bremsscheibe führen und an der Achsbrücke befestigen (Bild M 110-M 111).

WICHTIGE HINWEISE zur Bremssattelbefestigung:

An beiden Stirnseiten der DISTANZSCHEIBE Loctite (Nr. 648) anbringen — siehe Bild M 110/Pfeile!

Gewinde von Paßschraube und Sechskantmutter mit Loctite versehen!

Paßschraube bzw. Sechskantschraube in die vorgesehenen Bohrungen einsetzen!

Paßschraube zuerst festziehen (M 16 x 1,5/12.9 = 380 Nm)!

Abstand zwischen Bremsbelägen und Bremsscheibe mit Fühllehre (Spion) jeweils innen und außen bzw. oben und unten messen!

HINWEISE: Bremssattel muß parallel und mittig zur Bremsscheibe am Bremsträger (Achsbrücke) befestigt werden!

Diese vorgeschriebene Einbaulage wird durch den Einbau entsprechender dicker DISTANZSCHEIBEN korrigiert!

Die Sicherungselemente an der Paß- bzw. Sechskantschraube sind je nach Bremsentype verschieden!

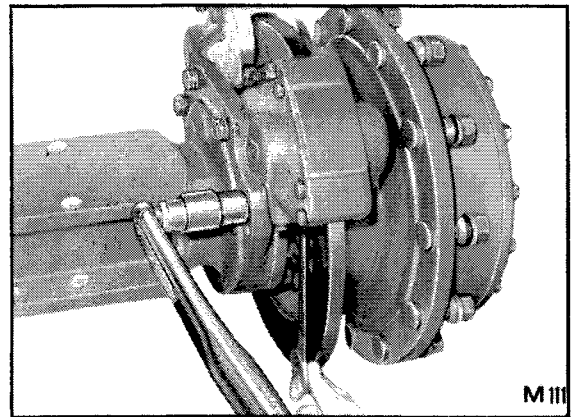
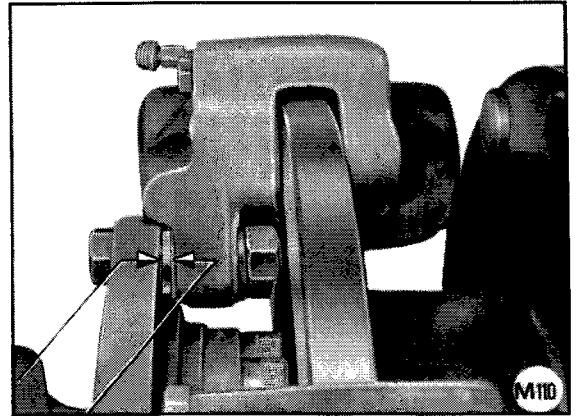

WERKZEUGVERZEICHNIS ZUM DE- UND MONTIEREN VON:

Erläuterungen zu den angeführten ZAHLEN BEI DEN SPALTEN DE- UND MONTAGE:

z.B.: 1/74 = TAFEL/BILDNUMMER

3/1 BILD = REGISTER/fortlaufende BILDNUMMER

DEMONTAGE	MONTAGE	Bezeichnung des Kundendienst-Werkzeuges (■) und dessen Verwendung	Sach-Nr.
	Bild M/2	Aufsetzer (*) HM 804 810 (D-Trieb) _____ zum Einsetzen des Kegelrollenlageraußenringes 0635 401 061 in die Lagerbuchse.	5870 058 022
	Bild M/2	Aufsetzer (*) HM 907 614 (H-Trieb) _____ zum Einsetzen des Kegelrollenlageraußenringes 0635 501 030 in die Lagerbuchse.	5870 058 073
		Aufsetzer (*) HM 813 810 (L-Trieb) _____ zum Einsetzen des Kegelrollenlageraußenringes 0635 501 086 in die Lagerbuchse.	5870 058 079
		Aufsetzer (*) HM 807 010 (L-Trieb) _____ zum Einsetzen des Kegelrollenlageraußenringes 0635 501 051 in die Lagerbuchse.	5870 058 078
		Aufsetzer (*) H 715 311 (R-Trieb) _____ zum Einsetzen des Kegelrollenlageraußenringes 0635 501 084 in die Lagerbuchse.	5870 058 077
		Aufsetzer (*) H 913 810 (R-Trieb) _____ zum Einsetzen des Kegelrollenlageraußenringes 0635 501 612 in die Lagerbuchse	5870 058 081
		Aufsetzer 31 315 (S-Trieb) _____ zum Einsetzen des Kegelrollenlageraußenringes 0635 375 023 in die Lagerbuchse. Nur verwendbar mit Griff 5870 260 004.	5870 050 007
		Griff _____ für Aufsetzer der Werkzeugreihe 5870 050 . . .	5870 260 004
	Bild M/3	Meßwelle _____ in Verbindung mit Paßscheiben zum Ausmessen des Achstriebegehäuses.	5870 500 001
	Skizze	Paßscheiben (D-Trieb) _____ Außen Ø 110 und 112,7 mm.	5870 500 005
		Paßscheiben (H-Trieb) _____ Außen Ø 120 mm	5870 500 006
		Paßscheiben (L-Trieb) _____ Außen Ø 125,4 und 133,3 mm	5870 500 007
		Paßscheiben _____ Außen Ø 152,4 mm	5870 500 008
	Bild M/5	Meßleiste 600 mm lang _____ für diverse Meßvorgänge. Universeller Gebrauch.	5870 200 022
	Bild M/6	Heißluftgebläse 220 V 50 Hz _____	5870 221 500
		Heißluftgebläse 127 V 60 Hz _____ zum Anwärmen von Gehäuse und Lagerteilen. Universeller Gebrauch.	5870 221 501

Hinweis zu (*): Nur verwendbar mit Griff 5870 260 002

AUSGABE:

LIST OF SPECIAL TOOLS FOR THE DISASSEMBLY AND REASSEMBLY:

Explanations to the identified ITEMS SEE COLUMNS DISASSEMBLY AND REASSEMBLY:

e.g.: 1/74 = TABLE NO./ITEM NO.

3/1 FIGURE = SECTION/current FIG. NO.

DISASSEMBLY	REASSEMBLY	Designation and application of the Special Tool (■)	NO. OF Special Tool
Fig. D/16		<u>Fixture adjustable</u> to hold tight the drive flange when loosening and tightening the bevel gear connection.	5870 240 002
Fig. D/18		<u>Suspension hook</u> to lift out and replace the complete bearing cage.	5870 281 003
Fig. D/20		<u>Basic set Rollex I</u> combined with:	5870 026 000
		<u>Grab sleeve "Super" Storage-No. HM 804 848</u> to pull the tapered roller bearing inner race series HM 804 800 off the bevel pinion (D-Drive).	5870 026 012
		<u>Grab sleeve "Super" Storage-No. HM 907 643</u> to pull the tapered roller bearing inner races series HM 907 600 off the bevel pinion (H-Drive).	5870 026 014
		<u>Basic set Rollex II</u> combined with:	5870 027 000
		<u>Grab sleeve "Super" Storage-No. HM 813 841</u> to pull the tapered roller bearing inner race series HM 813 800 off the bevel pinion (L-Drive).	5870 027 013
		<u>Grab sleeve "Super" Storage-No. HM 913 849</u> to pull the tapered roller bearing inner race series HM 913 800 off the bevel pinion. To be used only combined with: (R-Drive) Basic set Rollex III 5870 029 000 or <u>Pressure ring 5870 029 004</u> and hydraulic press	5870 029 003
		<u>Basic set Rollex II</u> combined with:	5870 027 000
		<u>Grab sleeve Storage-No. 31315</u> to pull the tapered roller bearing inner race R 31315 off the bevel pinion (S-Drive).	5870 027 002

Note for (*): To be used only together with handle, Special Tool 5870 260 002

EDITION:



Bild 3
Figure 3

ADJUSTMENT OF THE BACKLASH AND THE BEARING PRELOAD OF A ZF-DIFFERENTIAL CARRIER

Figure 1 - 2:

Screw in both adjusting nuts until the correct backlash, etched upon the outer diameter of the crown wheel and the correct yoke width have been established. (See page "Adjustment Values for ZF-Axles".)

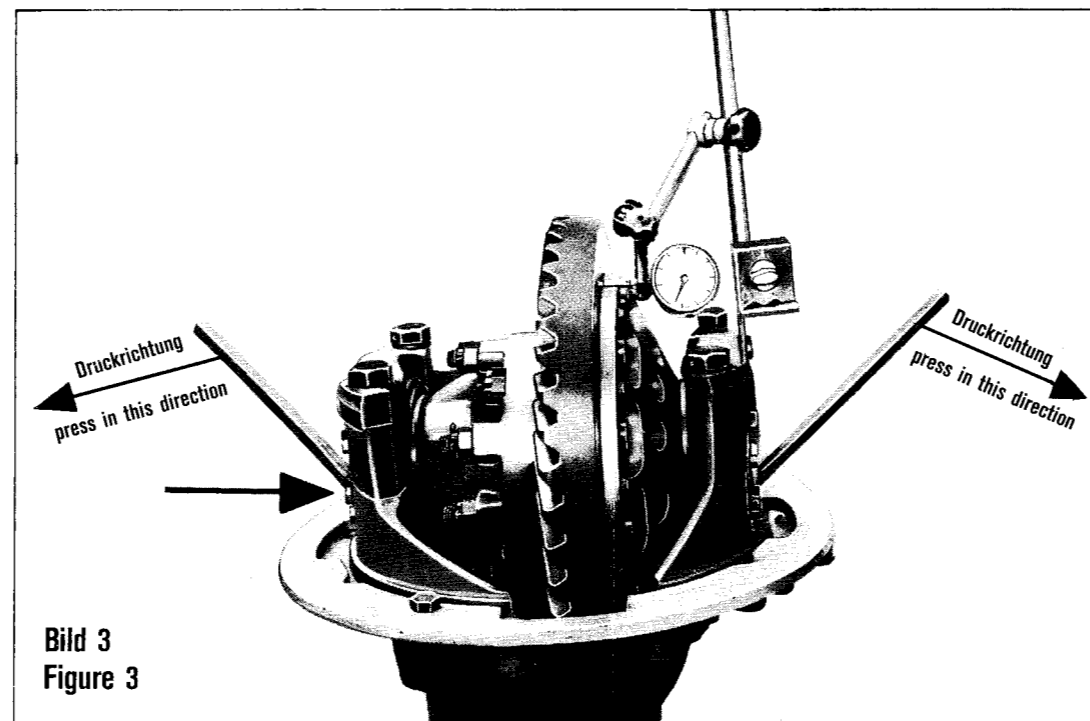
Mount dial indicator to contact the tooth flank of the crown wheel at a right angle.

Determine actual backlash by moving the crown wheel, paying attention, however, not to move the drive pinion.

Since the adjusting nuts cannot be secured infinitely it may happen that the correct backlash of 0,30 mm, indicated upon the crown wheel, cannot be established exactly so that the bearing preload is going to be lightly exceeded or decreased. In this case, the adjusting nuts can be backed off or tightened for a maximum of 1/2 notch for correct securing. After the coating of several tooth flanks of the crown wheel the gear-tooth-contact pattern can be determined by rotating the drive pinion.

Example:

See page "Examples for Gear-Tooth-Contact Patterns of Klingelnberg and Gleason Gear-Tooth Systems".

If there would be greater variations of these Contact Patterns a failure in setting the drive pinion to the correct distance has been made. **This failure must be absolutely corrected!**

A second way is described as follows:

Figure 3:

Install dial indicator - at a right angle - at the machined backface of the crown wheel. Move the differential assembly axially without force, using 2 short pry bars, which must be placed between the adjusting nuts and the side gears. During this operation the dial indicator records the actual end play. Screw in the adjusting nut on the opposite side of the crown wheel (arrow) until the end play is eliminated. Now tighten the adjusting nut for 2 notches.

According to our experiences this will lead to a bearing preload of 2,9 - 4 Nm*) (0,29 - 0,4 kpm) .

Check for runout

Figure 4:

Install dial indicator - at a right angle - at the machined backface of the crown wheel. When the crown wheel is rotated the dial indicator records the runout.

The maximal admissible runout may be 0,08 mm! *) Note: Where an error of 2% is tolerated, we calculate: 1 kpm = 10 Nm



Bild 4
Figure 4

CLICK HERE TO **DOWNLOAD** THE COMPLETE MANUAL

- Thank you very much for reading the preview of the manual.
- You can download the complete manual from: www.heydownloads.com by clicking the link below

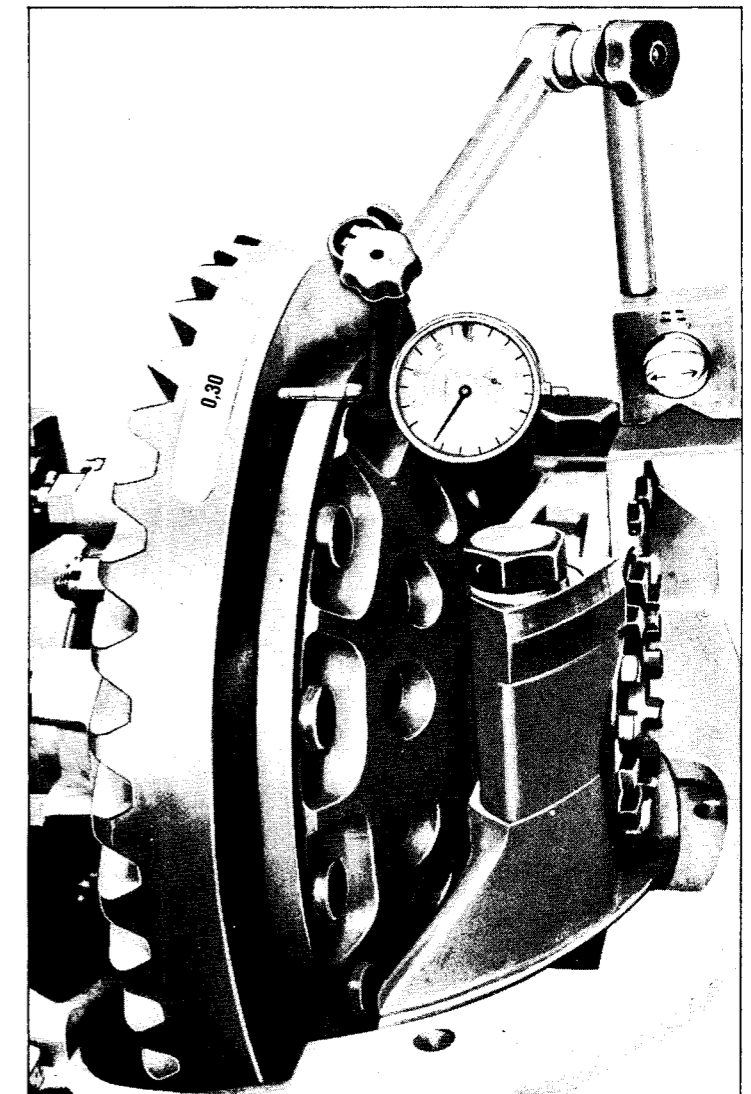

- Please note: If there is no response to CLICKING the link, please download this PDF first and then click on it.

CLICK HERE TO **DOWNLOAD** THE COMPLETE MANUAL