



SUZUKI MOTOR CORPORATION

SUZUKI

SQ420WD

SUPPLEMENTARY WIRING DIAGRAM MANUAL

99512-68D10-015

©



SQ420WD

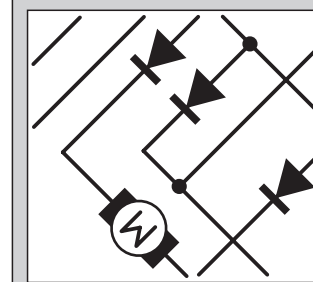

SUPPLEMENTARY
WIRING DIAGRAM MANUAL
ANHANG ZUM HANDBUCH FÜR
VERKABELUNG
MANUEL DES SCHEMAS DE CABLAGE
SUPPLEMENTAIRE
MANUAL DE DIAGRAMA DE CONEXIONES
SUPLEMENTARIO

SUZUKI
Caring for Customers
99512-68D10-015
(英)(独)(仏)(西)

CLICK HERE TO **DOWNLOAD** THE COMPLETE MANUAL

- Thank you very much for reading the preview of the manual.
- You can download the complete manual from: www.heydownloads.com by clicking the link below



- Please note: If there is no response to CLICKING the link, please download this PDF first and then click on it.

CLICK HERE TO **DOWNLOAD** THE COMPLETE MANUAL

CONTENU ET DESCRIPTION DU MANUEL

Ce manuel contient les schémas indiquant les positions d'installation des pièces individuelles (fusibles, relais, blocs de commande), les points de mise à la masse, le circuit d'alimentation et les circuits électriques.

SECTION		DESCRIPTION
Schéma des positions d'implantation des blocs raccord de câblage	8A-3	L'agencement des blocs raccord de câblage utilisés dans ce véhicule est représenté par rapport aux faisceaux de fils électriques en se servant de symboles dans les illustrations.
Positions d'installation des pièces individuelles	8A-4	Indication de la position de chaque fusible, relais et bloc de commande dans le véhicule.
Point de masse	8A-5	Indication des points de mise à la masse sur la carrosserie.
Schéma du circuit d'alimentation	8A-6	Indique le passage du courant électrique de la borne positive de la batterie au fusible principal et chaque fusible du boîtier à fusibles ainsi que les noms des principaux systèmes qui appliquent une charge à chaque fusible indiqué.
Schéma des systèmes électriques	8A-7	Indication du circuit électrique de chaque système, du fusible à la masse. Le schéma est construit de manière à indiquer le sens du courant du haut en bas.
Liste des blocs raccord de câblage	8A-8	Formes des blocs raccord de câblage utilisés dans ce véhicule et agencement de leurs broches comme représenté.

DÉTAILS DES APPLICATIONS

Ce manuel couvre les modèles ci-dessous.

REMARQUE :

Les descriptions de ce manuel peuvent ne pas correspondre exactement au véhicule réparé compte tenu de certaines différences techniques.

MODEL

(X) JSAFTD82V00100001(X) ~

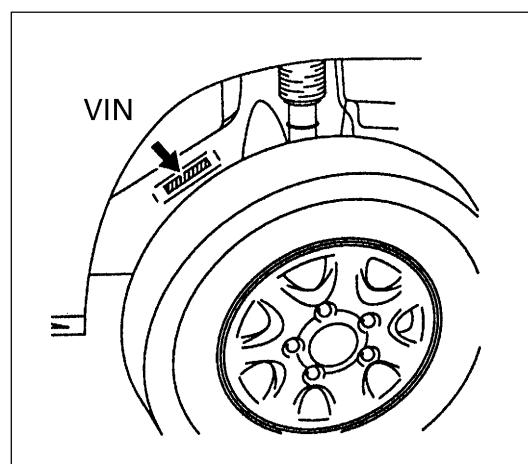

VIN: Numéro d'identification du véhicule

	ENGLISH	DEUTSCH	FRANÇAIS	ESPAÑOL
CONNECTOR NO. STECKER NR. CONNECTEUR NO. CONECTOR N.	CONNECTIVE POSITION	ANSCHLUSSPOSITION	POSITION DE RACCORDEMENT	POSICIÓN DE CONEXIÓN
	BATTERY CABLE	BATTERIEKABEL	CÂBLE DE BATTERIE	CABLE DE LA BATERÍA
A01	MAIN FUSE	HAUPTSICHERUNG	FUSIBLE PRINCIPAL	FUSIBLE PRINCIPAL
A04	STARTING MOTOR	STARTERMOTOR	DÉMARREUR	MOTO DE ARRANQUE
A08	GENERATOR	GENERATOR	GENERATEUR	GENERADOR
A09	ENGINE HARNESS (TO C83)	MOTORKABELBAUM (ZUR C83)	FAISCEAU DE FILS ÉLECTRIQUES DE MOTEU (VERS C83)	MAZO DE CABLES DEL MOTOR (AL C83)

G Q INSTRUMENT PANEL (RHD)
ARMATURENBRETT (RHD)
PANNEAU D'INSTRUMENTS (CONDUITE À DROITE)
TABLERO DE INSTRUMENTOS (RHD)

G: INSTRUMENT PANEL HARNESS
G: ARMATURENBRETT-KABELBAUM
G: FAISCEAU DE FILS ÉLECTRIQUES DE PLANCHE DE BORD
G: MAZO DE CABLES DEL TABLERO DE INSTRUMENTOS

Q: AIR BAG HARNESS , PRETENSIONER WIRE
Q: AIRBAG-KABELBAUM, VORSPANNERKABEL
Q: FAISCEAU DE FILS ÉLECTRIQUES DE SAC GONFLABLE, FIL DE PRETENSIONNEUR
Q: MAZO DE CABLES DEL COLCHEÓN DE AIRE, CABLE DE PRETENSOR

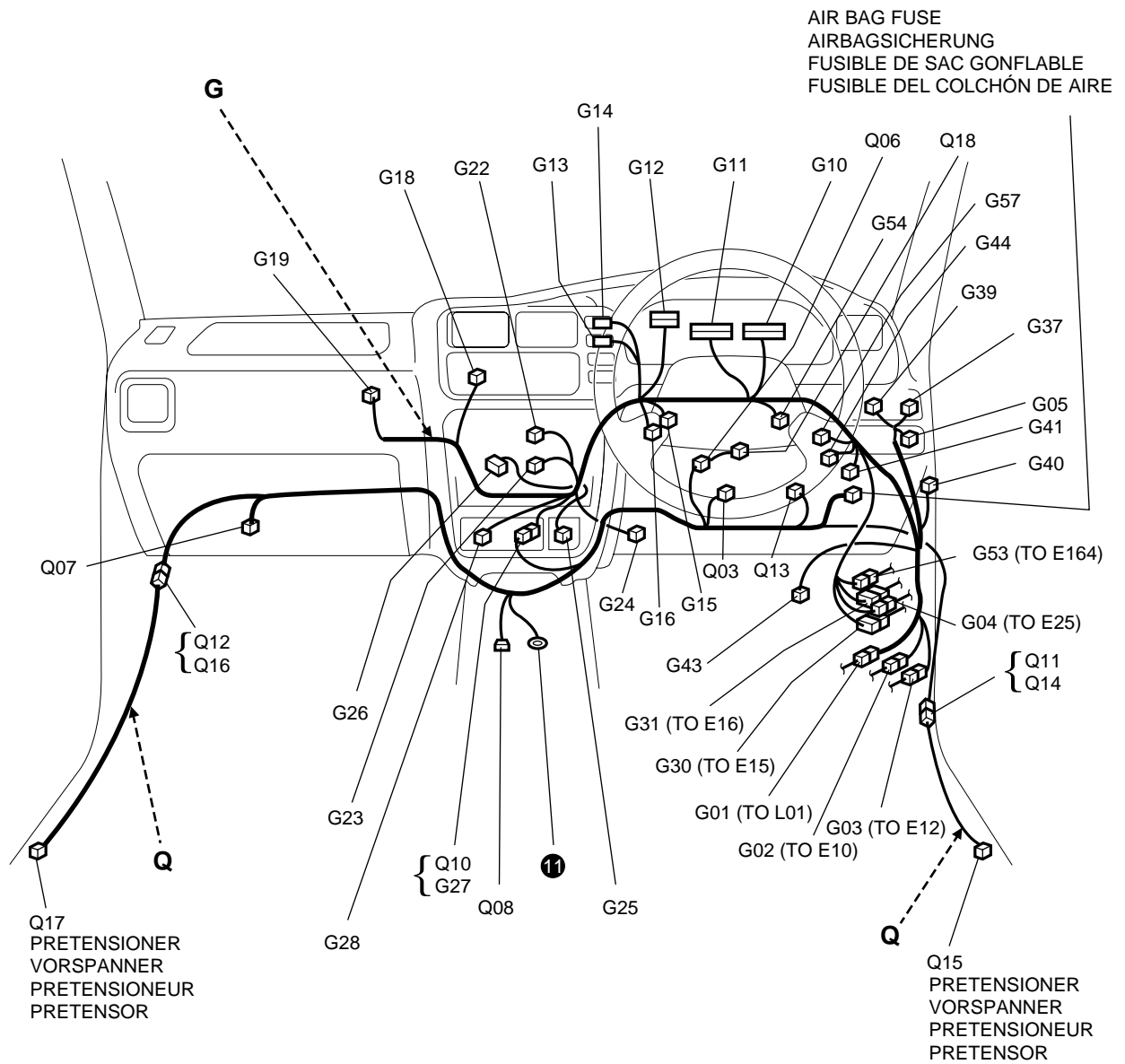

L R FLOOR (RHD)
 BODEN (RHD)
 PLANCHER (CONDUITE À DROITE)
 PISO (RHD)

L:FLOOR HARNESS
 L:BODENWANNEN-KABELBAUM
 L:FAISCEAU DE FILS ÉLECTRIQUES DE PLANCHER
 L:MAZO DE CABLES DEL PISO

R:FUEL WIRE,FUEL PUMP WIRE
 R:KRAFTSTOFFKABEL,KRAFTSFTOFFPUMPENKABEL
 R:FIL DU SYSTÈME D'ALIMENTATION EN
 CARBURANT,
 FIL DE POMPE À ESSENCE
 R:CABLE DE CONTROL DE COMBUSTIBLE,
 CABLE DE BOMBA DEL COMBUSTIBLE

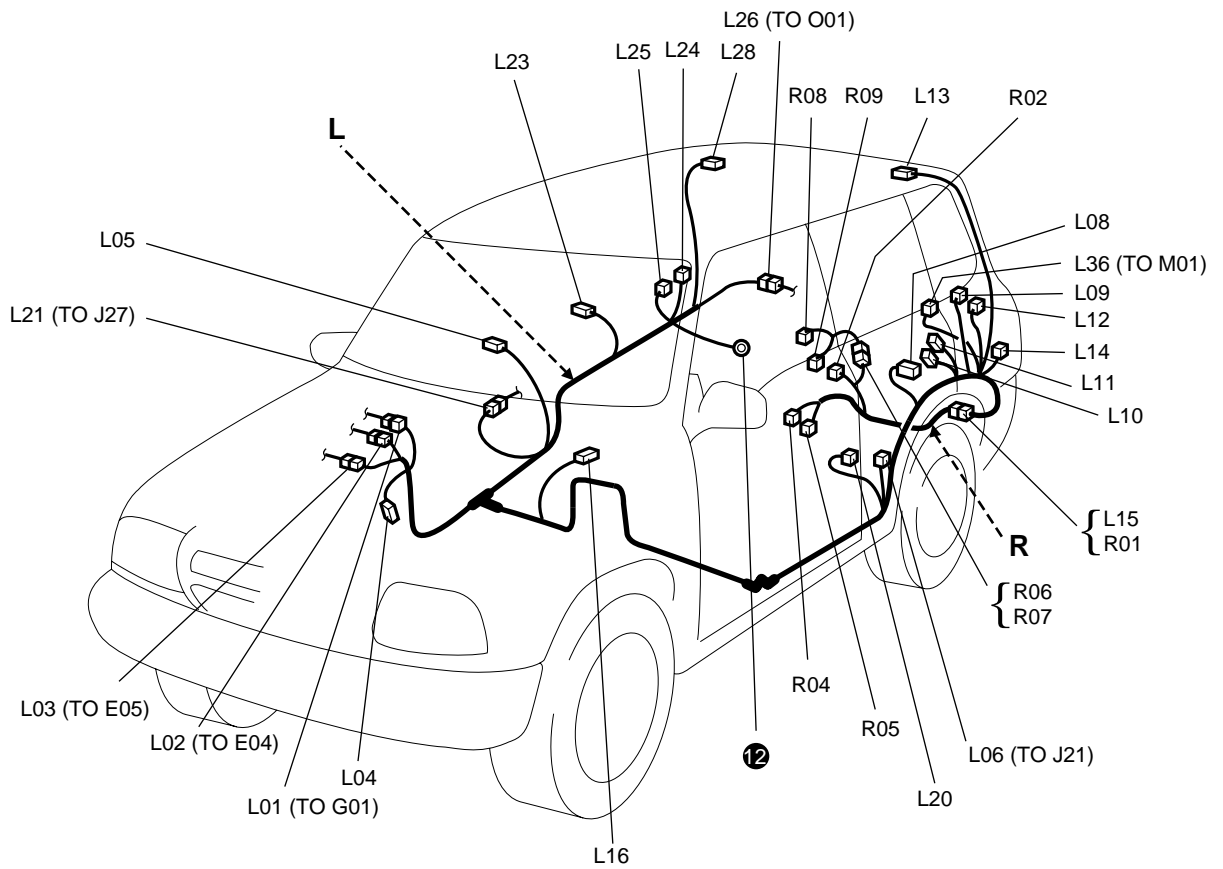

REAR
HINTEN
ARRIÈRE
PARTE TRASERA

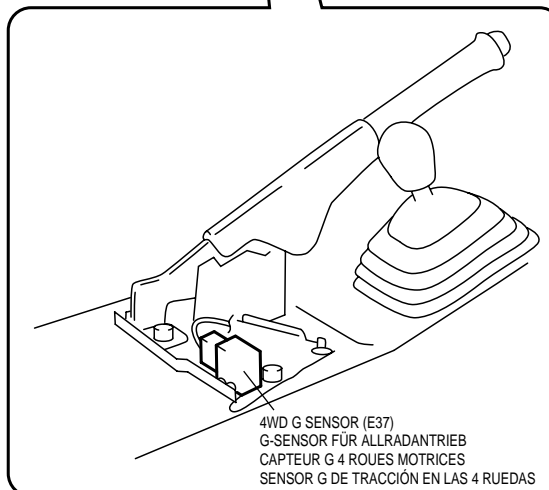
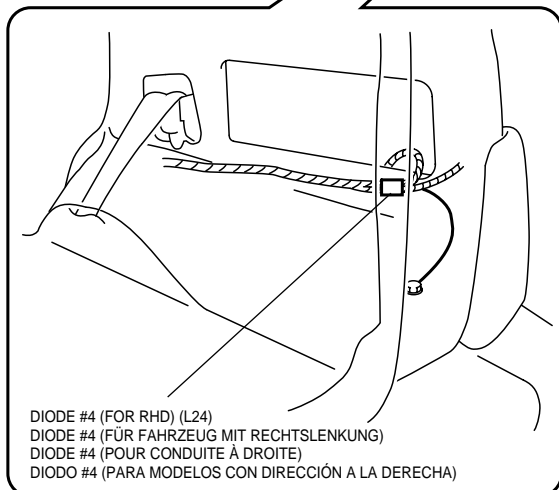
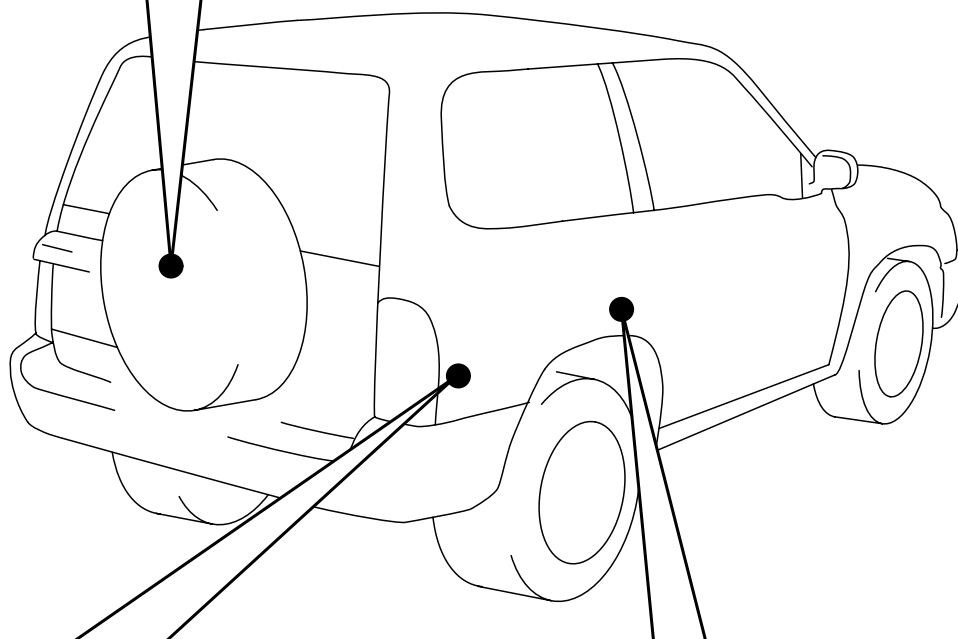
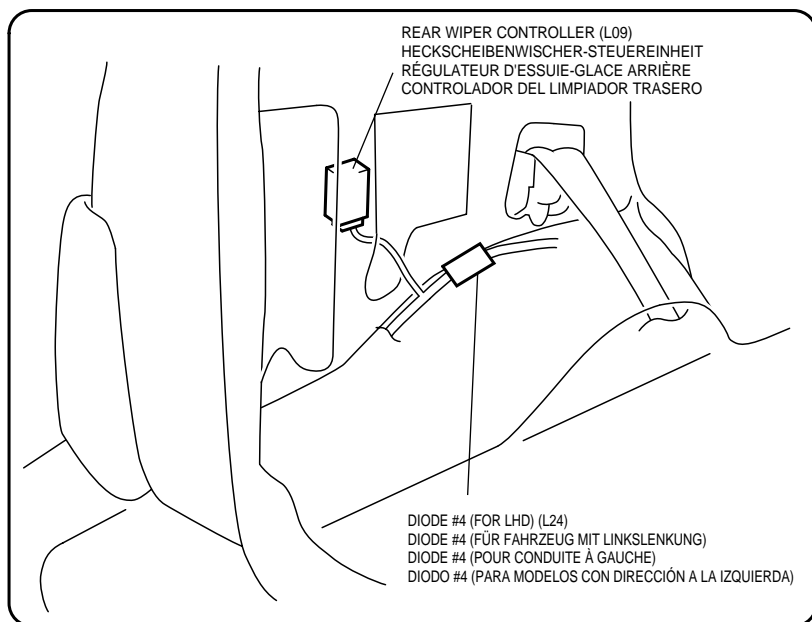

CLICK HERE TO **DOWNLOAD** THE COMPLETE MANUAL

- Thank you very much for reading the preview of the manual.
- You can download the complete manual from: www.heydownloads.com by clicking the link below



- Please note: If there is no response to CLICKING the link, please download this PDF first and then click on it.

CLICK HERE TO **DOWNLOAD** THE COMPLETE MANUAL

A-1 CHARGING SYSTEM
A-1 LADESYSTEM
A-1 SYSTÈME DE CHARGE
A-1 SISTEMA DE CARGA

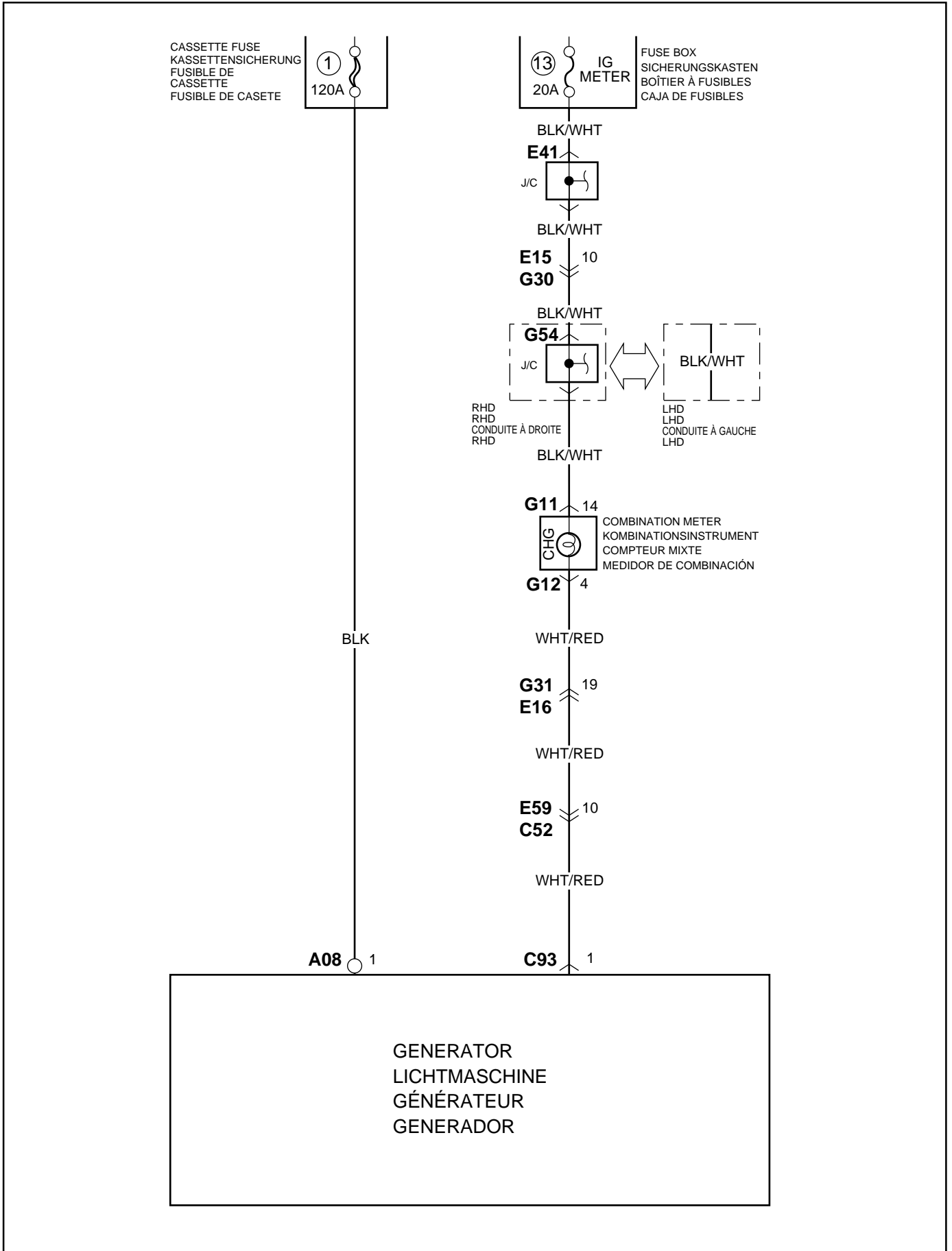

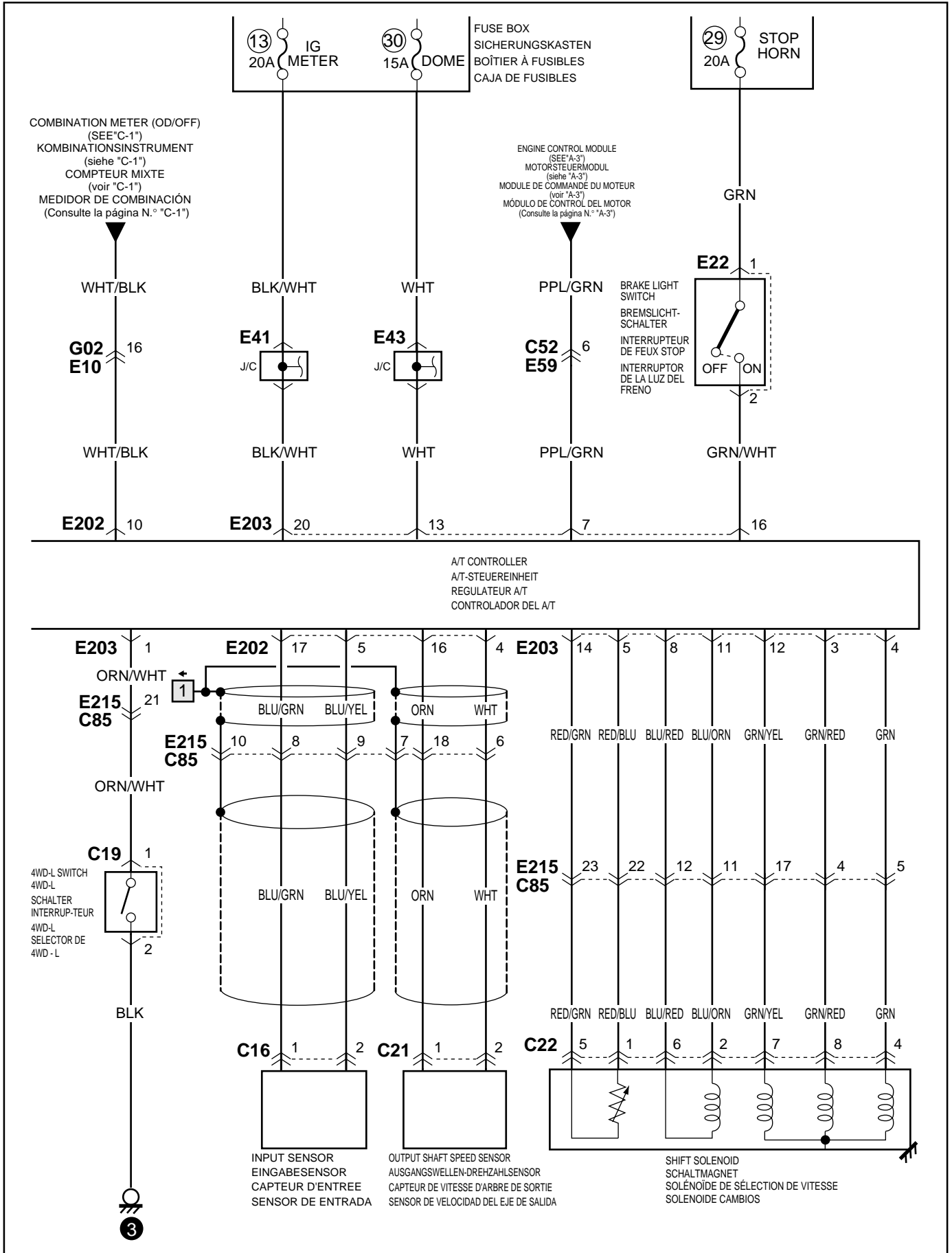

B-6 REMOTE CONTROLLED MIRROR WITH HEATER MIRROR (OPTION)
B-6 FERNGESTEUERTER SPIEGEL MIT BEHEIZTEM SPIEGEL (OPTION)
B-6 RETROVISEUR TELECOMMANDE AVEC RECHAUFFEUR DE RETROVISEUR (OPTION)
B-6 ESPEJO DE CONTROL REMOTO CON CALENTADOR DE ESPEJO (OPCIONAL)

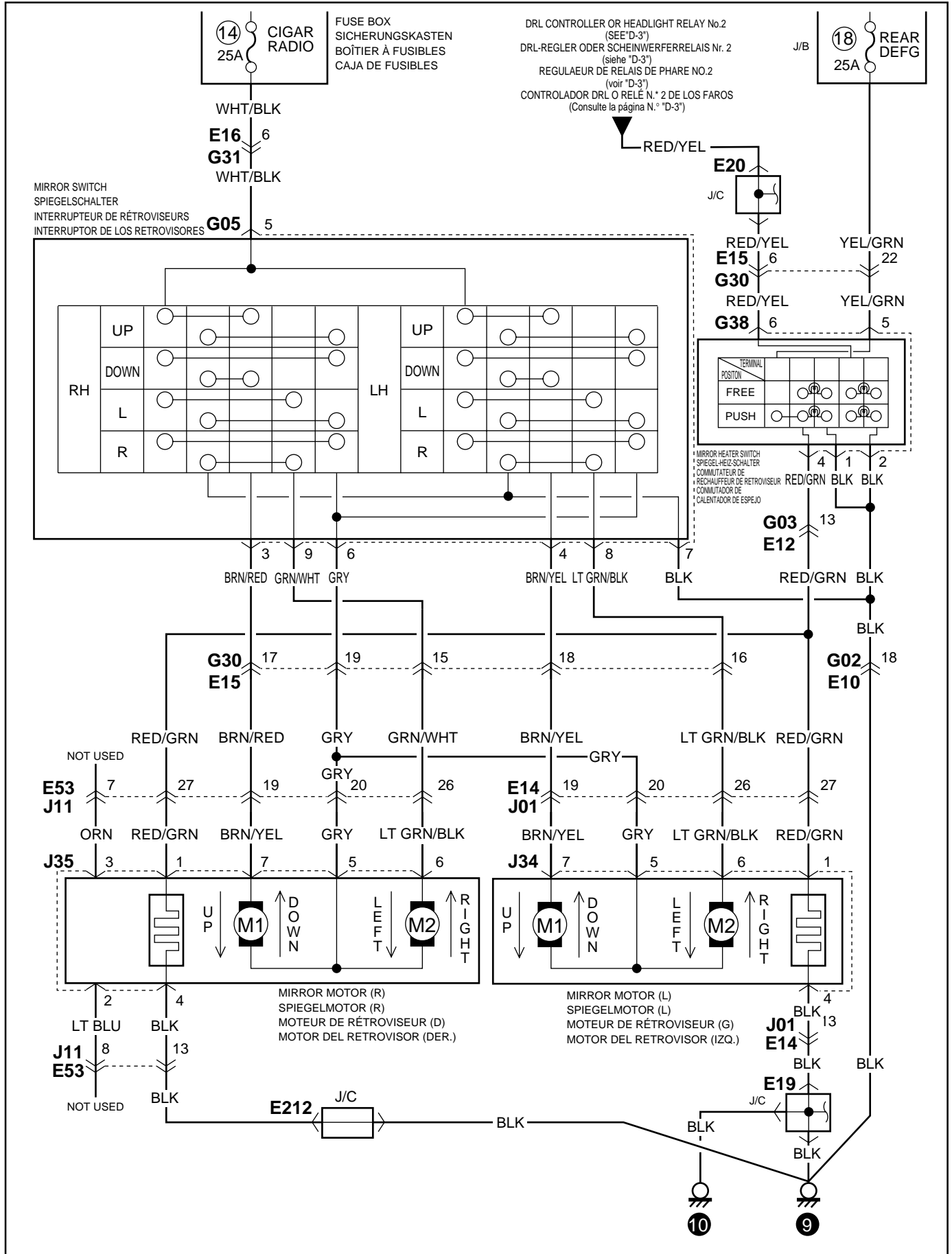

D-1 HEADLIGHT SYSTEM (RHD)
D-1 SCHEINWERFRANLAGE (RHD)
D-1 SYSTÈME DES PHARES (CONDUITE À DROITE)
D-1 SISTEMA DE LOS FAROS (RHD)

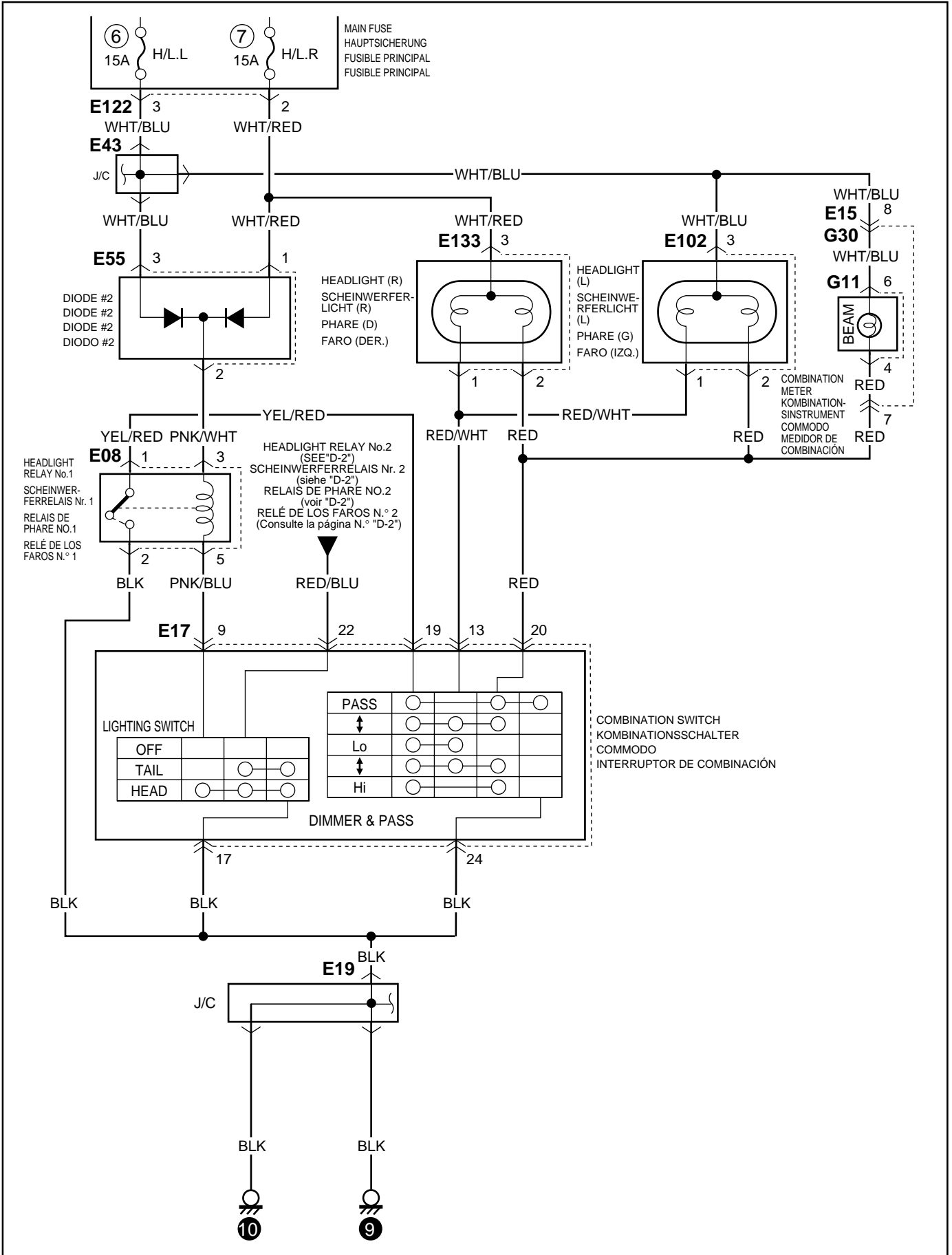

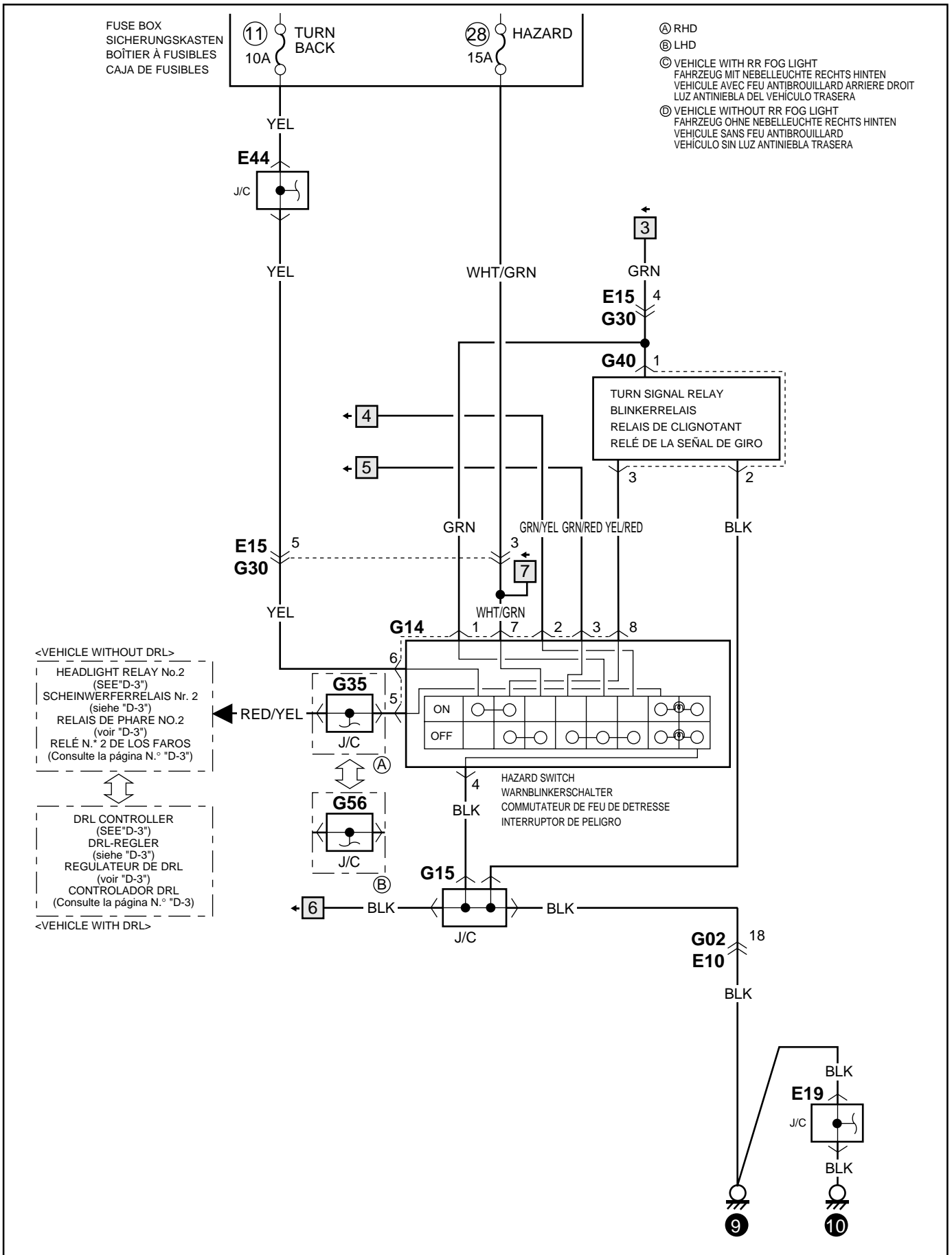

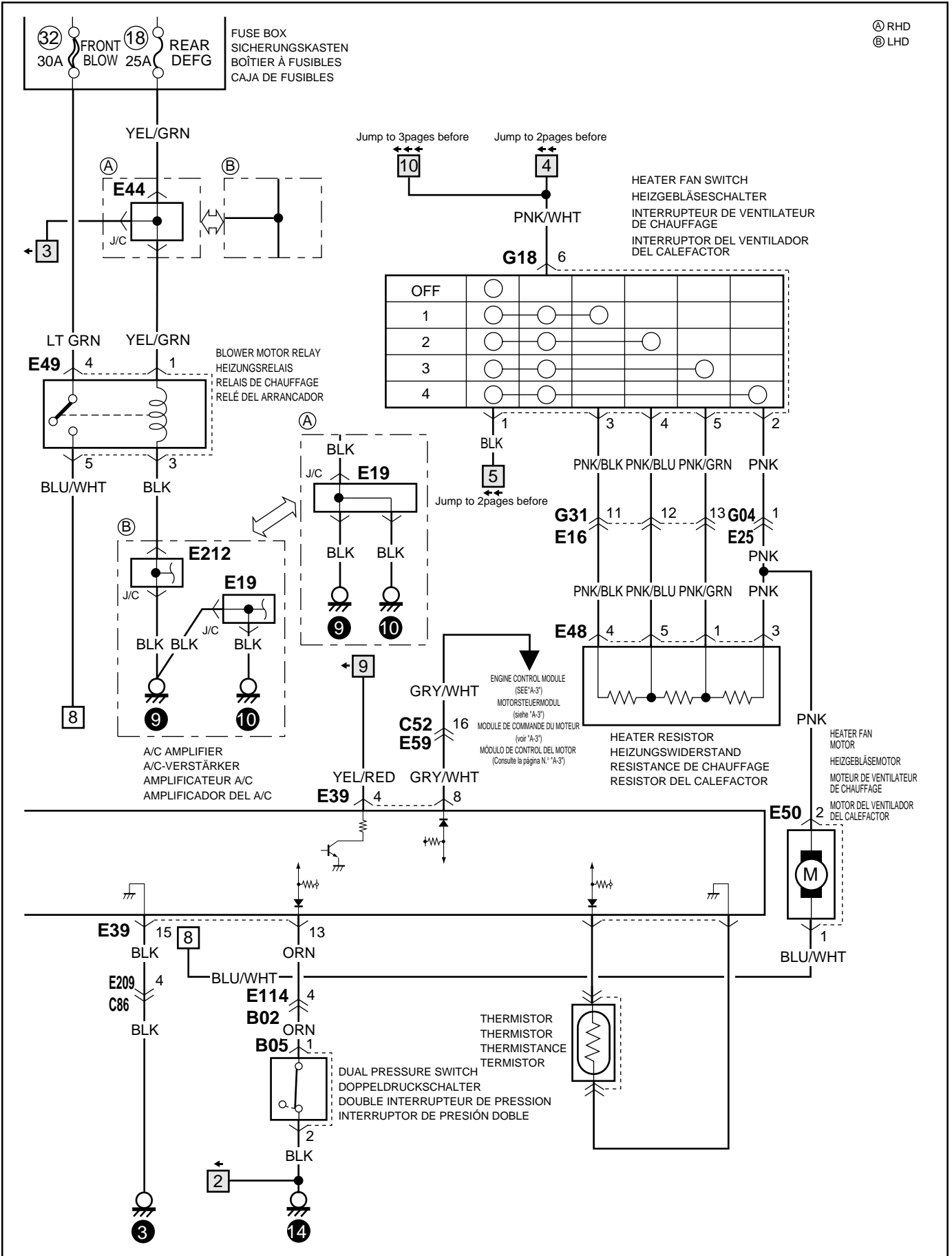











List of connectors
Liste der stecker
Liste des blocs raccord de câblage
Lista de conectores

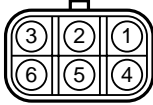

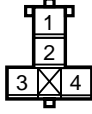

A Connector
 A Stecker
 A Connecteur
 A Conector

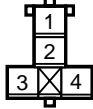
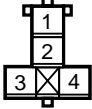
A01	A04	A08	A09 (TO C83)		
					

B Connector
 B Stecker
 B Connecteur
 B Conector

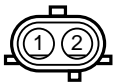
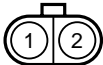
B01(TO E115)	B02(TO E114)	B03	B04	B05	B06
					
B07	B08	B09			
					

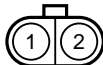
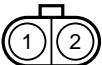
C Connector
 C Stecker
 C Connecteur
 C Conector

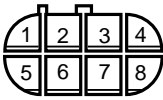
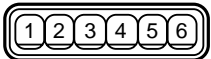
C04	C14	C15	C16	C18	C19
					
C20	C21	C22	C32		
					

NOTE: Connector No. in () means one of the mating intermediate connector./Die in Klammern () ausgüehfrte Stecker-Nr. bezeichnet den zugehörigen Zwischenstecker./
 Le numéro de bloc raccord de câblage indiqué entre parenthèses () correspond au bloc raccord de câblage intermédiaire apparié./
 El N.º de conector entre () indica un conector intermedio correspondiente.

CLICK HERE TO **DOWNLOAD** THE COMPLETE MANUAL

- Thank you very much for reading the preview of the manual.
- You can download the complete manual from: www.heydownloads.com by clicking the link below



- Please note: If there is no response to CLICKING the link, please download this PDF first and then click on it.

CLICK HERE TO **DOWNLOAD** THE COMPLETE MANUAL