

Project description                      BF300C  
 Designazione dell'impianto  
 Drawing number                              71  
 numero disegno

Pages      78  
 pagine

0	1	2	3	4	5	6	7	8	9					
Created Realizzato	L.Zuccarino 18/10/2010	BF300C		Foglio del titolo / copertina					Higher-level function Impianto	=	Page Pagina	1	from pag.	78
Checked Controllato	R.Zaniboni 20/10/2010								Function Funzione	==			71	
									Mounting location Montaggio località	+				

CLICK HERE TO **DOWNLOAD** THE COMPLETE MANUAL

- Thank you very much for reading the preview of the manual.
- You can download the complete manual from: [www.heydownloads.com](http://www.heydownloads.com) by clicking the link below



- Please note: If there is no response to CLICKING the link, please download this PDF first and then click on it.

CLICK HERE TO **DOWNLOAD** THE COMPLETE MANUAL

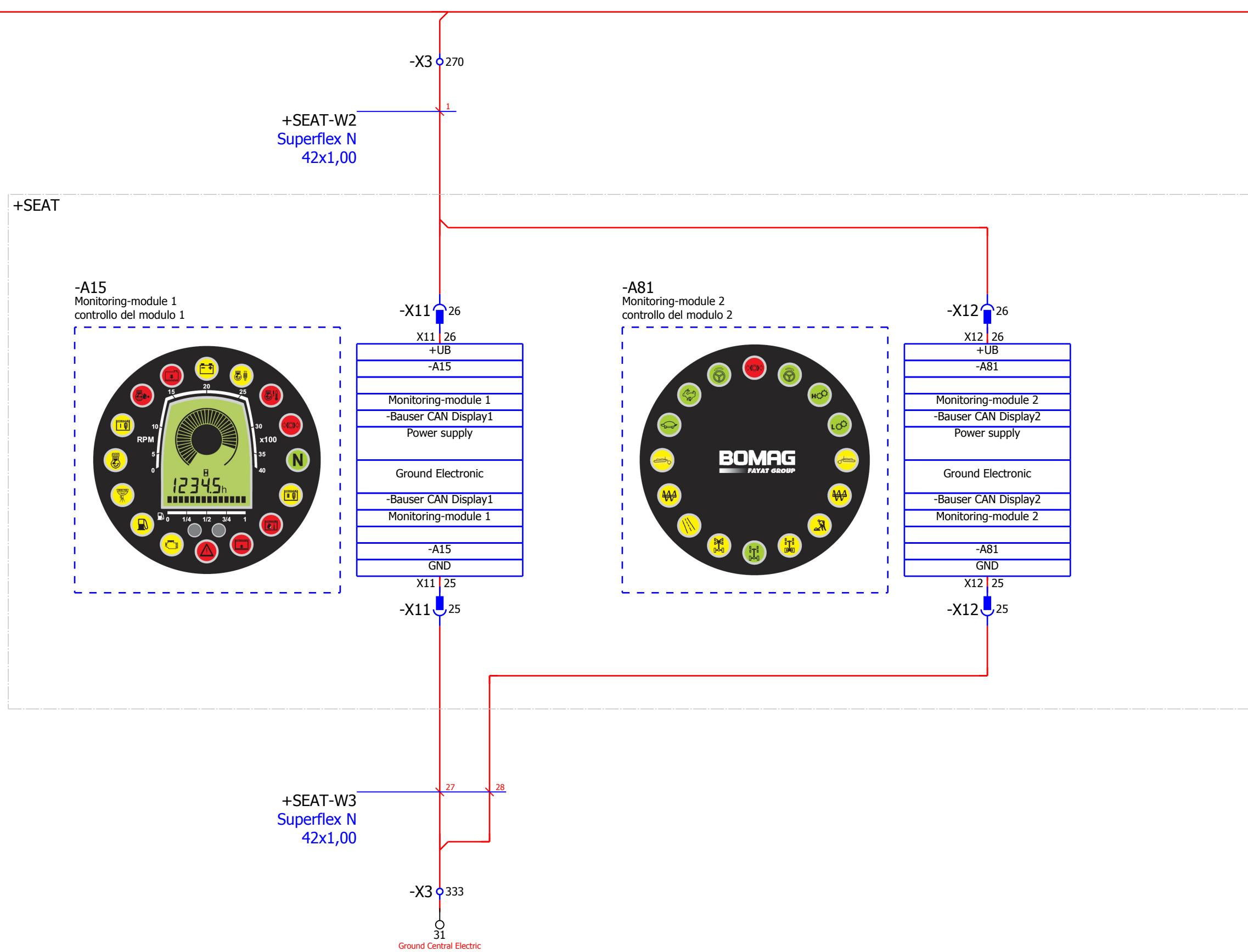

==SUPL/10.8 ~ F173

F173 ~ 24.1

+SEAT

==DRIV/22.8 ~ Neutral

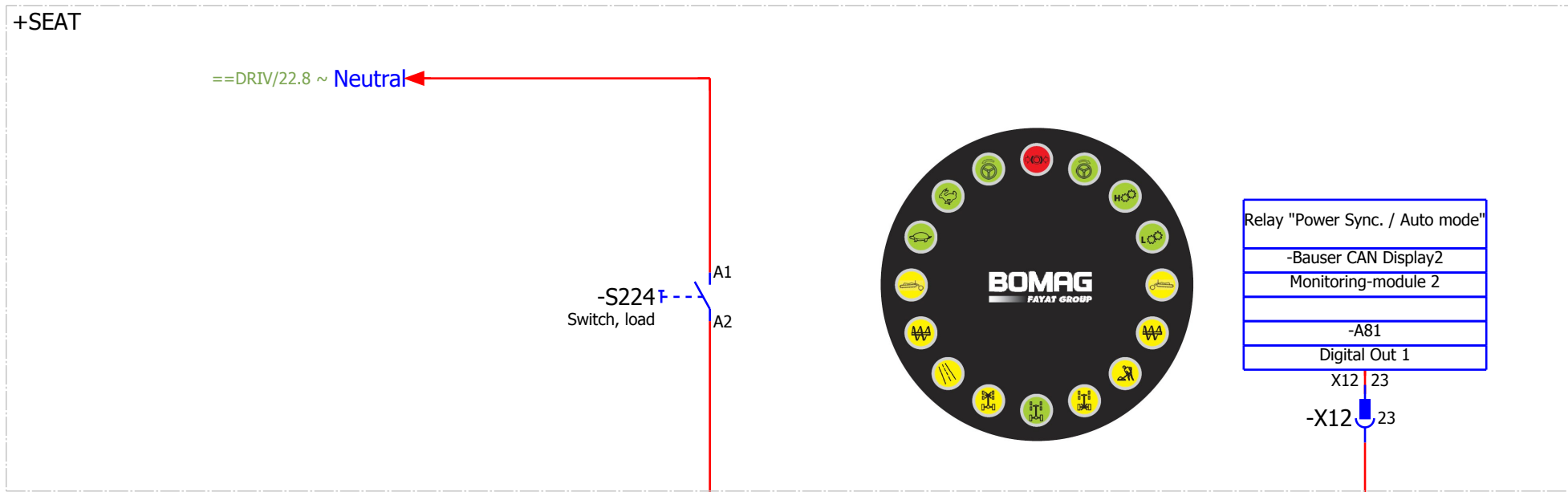

-K162 /23.5  
Relay, automatic mode

30  
87a 87

AUTO\_DLY ~ 24.1

MAN\_DLY ~ 35.4

+SEAT-W2  
Superflex N  
42x1,00

+SEAT-W3  
Superflex N  
42x1,00

==DRIV/19.6 PWR\_REQ\_LOAD

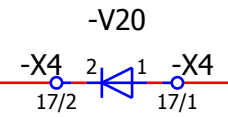
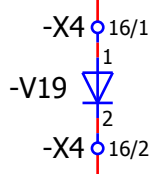
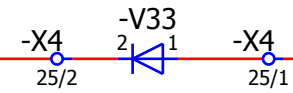

-K163  
Relay, load

-K162  
Relay, automatic mode

-X2 23

-X2 23

Ground Central Electric  
31

31

87

87a 30 ==SUPL/10.2

87

87a 30 /23.7

0

1

2

3

4

5

6

7

8

9

Created  
Realizzato

L.Zuccharino  
18/10/2010

Checked  
Controllato

R.Zaniboni  
20/10/2010

BF300C



Load

Higher-level function	= BF	Page	23	from	78
Implanto		Pagina		pag.	
Function	= PAV	71			
Funzione					
Mounting location	+ EBOX				
Montaggio località					

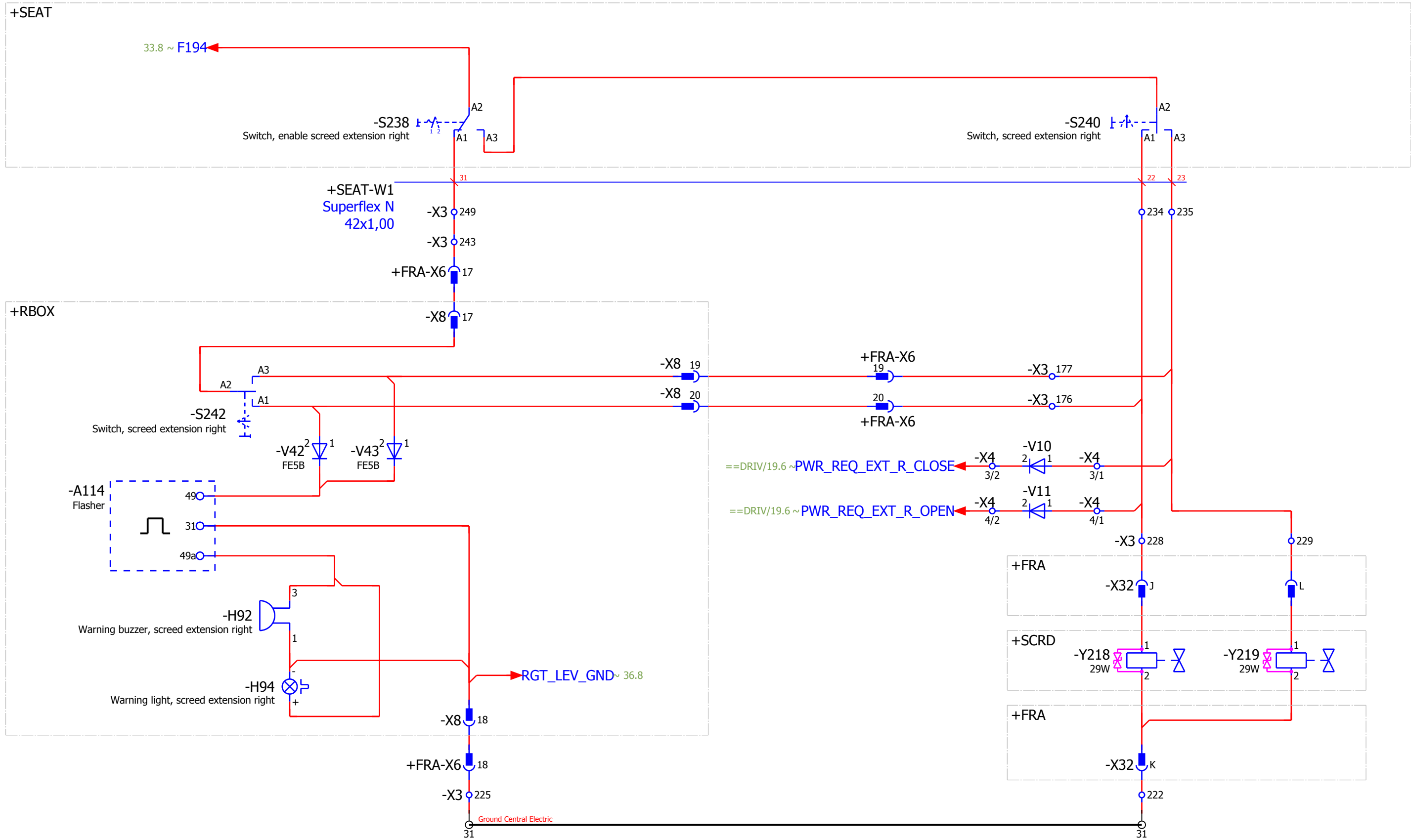

Solenoid valve, screed right open

Solenoid valve, screed right close

0	1	2	3	4	5	6	7	8	9					
Created Realizzato	L.Zuccharino 18/10/2010			Screed extension right					Higher-level function Impianto	= BF	Page Pagina	34	from pag.	78
Checked Controllato	R.Zaniboni 20/10/2010								BF300C	Function Funzione	= PAV	71		
								Mounting location Montaggio località	+ EBOX					

# Device tag list

## l'elenco componenti

Device tag SEF	Page pagina	Path col	Mounting location montaggio località	Higher-level function impianto	Function text	testo funzione	characteristics caratteristiche
F05	9	1	+EBOX	=BF	Fuse, Socket		15A
F13	9	2	+EBOX	=BF	Fuse, ignition Switch		15A
F16	9	8	+EBOX	=BF	Fuse, central lubrication		15A
F22	9	6	+EBOX	=BF	Fuse, working lights rear		25A
F23	9	2	+EBOX	=BF	Fuse, warning horns		10A
F30	9	8	+EBOX	=BF	Fuse, heating operators seat		15A
F41	9	6	+EBOX	=BF	Fuse, rotary beacon		10A
F48	6	2	+BAT	=BF	Fuse, glow plug system		40A
F67	9	4	+EBOX	=BF	Fuse, controller (pot.30)		15A
F104	9	5	+EBOX	=BF	Fuse, working lights front		25A
F148	9	2	+EBOX	=BF	Fuse, controller (Pot. 15)		10A
F157	9	3	+EBOX	=BF	Fuse, solenoid valve starter		30A
F170	9	6	+EBOX	=BF	Fuse, GEN-ON	fusibile, GEN-ON	40A
F171	10	1	+EBOX	=BF	Fuse, traction		10A
F173	10	1	+EBOX	=BF	Fuse, automatic functions		15A
F174	10	2	+EBOX	=BF	Fuse, conveying system		15A
F175	9	3	+EBOX	=BF	Fuse, screed heating pot. 15		15A
F177	10	1	+EBOX	=BF	Fuse, adjustment hoppers		10A
F179	10	4	+EBOX	=BF	Fuse, conveyor		10A
F180	10	4	+EBOX	=BF	Fuse, sensors		10A
F181	10	5	+EBOX	=BF	Fuse, augers		10A
F182	9	3	+EBOX	=BF	Fuse, sensors		5A
F184	10	6	+EBOX	=BF	Fuse, screed leveling		10A
F187	10	3	+EBOX	=BF	Fuse, crown screed		15A
F189	9	7	+EBOX	=BF	Fuse, cleaning		15A
F190	9	7	+EBOX	=BF	Fuse, spraying		15A
F192	10	3	+EBOX	=BF	Fuse, fume exhauster		10A
F194	10	2	+EBOX	=BF	Fuse, screed extension		10A
FM1	22	0	+EBOX	=BF	Multifuse		
FM2	22	0	+EBOX	=BF	-- " --	-- " --	
G01	6	1	+BAT	=BF	Battery	batteria	12V / 100Ah
G02	7	3	+MOT	=BF	Generator	generatore	
H07	16	2	+SEAT	=BF	Warning buzzer, breakdown		
H14	19	2	+FRA	=BF	Back-up alarm buzzer		
H46	40	2	+SEAT	=BF	Indicator light, head lights front		
H47	40	4	+SEAT	=BF	Indicator light, head lights rear		
H90	8	6	+SEAT	=BF	Indicator light, GEN-ON		

# Cable diagram

## lista cavi

Cable name nome cavo =BF+SEAT-W3	Cable type tipo cavo Superflex N		No. of conductors n° cond 42	Cross-section sezione 1,00	Remark nota			
Function text testo funzione	Page pagina	Path col	Target designation from destinazione da	Conductor cond	Target designation to destinazione a	Page pagina	Path col	Function text testo funzione
	22	6	X3 312	1	X27 1	22	6	
	13	5	X3 313	2	X34 C	13	5	
	13	7	X3 314	3	X34 D	13	7	
	16	2	X3 315	4	H07 +	16	2	Warning buzzer, breakdown
	19	2	X3 316	5	X11 23	19	2	
				6				Only used on BF 300 P
				7				
				8				Only used on BF 300 P
				9				Only used on BF 300 P
	13	4	X3 321	10	X34 J	13	4	
	13	4	X3 321	10	X34 M	13	4	
	13	4	X3 321	10	X34 N	13	5	
	40	6	X3 322	11	E72 X2	40	6	Illumination switches
	40	6	X3 322	12	H46 X2	40	2	Indicator light, head lights front
	40	6	X3 322	12	H47 X2	40	4	Indicator light, head lights rear
	8	6	X3 323	13	H90 X2	8	6	Indicator light, GEN-ON
	8	6	X3 323	14	H07 -	16	2	Warning buzzer, breakdown
	9	1	X3 324	15	XS -	9	1	Socket
	9	1	X3 324	16	XS -	9	1	-- " --
	23	5	X3 325	17	X12 23	23	5	
				18				Only used on BF 300 P
				19				Only used on BF 300 P
				20				Only used on BF 300 P
				21				Only used on BF 300 P
	22	2	X3 330	22	X20 2	22	2	
	22	2	X3 330	23	X36 A	22	5	
				24				Only used on BF 300 P

0	1	2	3	4	5	6	7	8	9				
Created Realizzato	L.Zuccharino 18/10/2010	BF300C		Cable diagram W3 Schema cablaggio W3				Higher-level function Impianto	=	Page Pagina	56	from pag.	78
Checked Controllato	R.Zaniboni 20/10/2010							Function Funzione	==	71			
								Mounting location Montaggio località	+				

# Plug overview

## descrizione del connettore

Designation descrizione	Mounting location montaggio località	Function text testo funzione
<b>XS</b>	<b>=BF+SEAT</b>	Socket
Contact contatto	Page pagina	Path col
	9	1
Type tipo	STH6	

Designation descrizione	Mounting location montaggio località	Function text testo funzione
<b>X5</b>	<b>=BF+FRA</b>	Plug, Screed (Screedpanel left)
Contact contatto	Page pagina	Path col
	17	2
Type tipo	Deutsch HDP 24-31 31pol	

1	17	2
2	17	3
3	18	6
4	18	6
5	27	2
6	27	2
7	28	6
8	28	6
9	31	6
10	31	6
11	31	7
12	29	1
13	29	1
14	29	2
15	31	2
16	31	2
17	33	3
18	33	3
19	33	6
20	33	6
21	36	2
22	36	2
23	36	3
24	36	3
25	36	3
26	36	3

Designation descrizione	Mounting location montaggio località	Function text testo funzione
<b>X6</b>	<b>=BF+FRA</b>	Plug, Screed (Screedpanel right)
Contact contatto	Page pagina	Path col
	17	7
Type tipo	Deutsch HDP 24-31 31pol	

1	17	7
2	17	8
3	18	3
4	18	4
5	27	6
6	27	6
7	28	8
8	28	8
9	31	8

Designation descrizione	Mounting location montaggio località	Function text testo funzione
<b>X6</b>	<b>=BF+FRA</b>	Plug, Screed (Screedpanel right)
Contact contatto	Page pagina	Path col
	31	8
Type tipo	Deutsch HDP 24-31 31pol	

10	31	8
11	31	9
12	29	7
13	29	7
14	29	7
15	31	2
16	31	2
17	34	3
18	34	3
19	34	6
20	34	6
21	36	6
22	36	6
23	36	7
24	36	7
25	36	7
26	36	7

Designation descrizione	Mounting location montaggio località	Function text testo funzione
<b>X7</b>	<b>=BF+LBOX</b>	Plug, Screedpanel left
Contact contatto	Page pagina	Path col
	17	2
Type tipo	Deutsch HDP 24-31 31pol	

1	17	2
2	17	3
3	18	6
4	18	6
5	27	2
6	27	2
7	28	6
8	28	6
9	31	6
10	31	6
11	31	7
12	29	1
13	29	1
14	29	2
15	31	1
16	31	1
17	33	3
18	33	3
19	33	4
20	33	4
21	36	2
22	36	2

CLICK HERE TO **DOWNLOAD** THE COMPLETE MANUAL

- Thank you very much for reading the preview of the manual.
- You can download the complete manual from: [www.heydownloads.com](http://www.heydownloads.com) by clicking the link below



- Please note: If there is no response to CLICKING the link, please download this PDF first and then click on it.

CLICK HERE TO **DOWNLOAD** THE COMPLETE MANUAL