

**SECTION B8-B9-B10 ...DIESEL ENGINE OPERATION
AND MAINTENANCE MANUAL AND MAINTENANCE
SCHEDULE MATRIX, TOOL LIST**

CLICK HERE TO **DOWNLOAD** THE COMPLETE MANUAL

- Thank you very much for reading the preview of the manual.
- You can download the complete manual from: www.heydownloads.com by clicking the link below





- Please note: If there is no response to CLICKING the link, please download this PDF first and then click on it.

CLICK HERE TO **DOWNLOAD** THE COMPLETE MANUAL

1 Safety

1.1	General conditions	1-01
1.2	Personnel and organizational requirements	1-02
1.3	Transport	1-03
1.4	Safety requirements when working on the engine	1-04
1.5	Auxiliary materials, fire prevention and environmental protection	1-07
1.6	Standards for warning notices in the publication	1-09

1.6 Standards for warning notices in the publication

 DANGER	In the event of immediate danger. Consequences: Death or serious injury. <ul style="list-style-type: none">• Preventive measures
 WARNING	In the event of possibly dangerous situations. Consequences: Death or serious injury. <ul style="list-style-type: none">• Preventive measures
 CAUTION	In the event of dangerous situations. Consequences: Slight injury or material damage. <ul style="list-style-type: none">• Preventive measures

Note: This Publication contains especially emphasized safety instructions in accordance with the American standard ANSI Z535, which begin with one of the above signal words according to the degree of danger:

Warning notices

1. Read and become acquainted with all cautions and symbols before operating or repairing this product.
2. Pass on all safety instructions to your operating, maintenance, repair and transport personnel!

2.6 Technical Data

2.6.1 8/12/16V 4000 engine data: Standby operation 3D, optimized fuel consumption

Explanation:

CP Ref. value: Continuous power (CP)

FSPRef. value: Fuel stop power (FSP)

A Design value

G Guaranteed value

R Guideline value

L Limit value, up to which the engine can be operated, without change (e.g. of power setting)

N Not yet defined value

- Not applicable

X Applicable

REFERENCE CONDITIONS

Engine model			8V	12V	12V	16 V	16 V
			4000 G61	4000 G21	4000 G61	4000 G21	4000 G61
Application group			3D	3D	3D	3D	3D
Intake air temperature		°C	25	25	25	25	25
Charge-air coolant temperature		°C	55	55	55	55	55
Raw water inlet temperature		°C	-	-	-	-	-
Barometric pressure		mbar	1000	1000	1000	1000	1000
Site altitude above sea level		m	100	100	100	100	100

POWER-RELATED DATA (power ratings are net brake power to ISO 3046)

Number of cylinders			8	12	12	16	16
	Engine rated speed	A	rpm	1500	1500	1500	1500
Fuel stop power ISO 3046	A	kW	985	1330	1465	1760	1940

GENERAL CONDITIONS (for maximum power)

Number of cylinders			8	12	12	16	16
	Intake air depression (new filter) (design)	A	mbar	30	30	30	30
Intake air depression (limit value)	L	mbar	50	50	50	50	50
Exhaust backpressure (design)	A	mbar	30	30	30	30	30
Exhaust backpressure (limit value)	L	mbar	51	51	51	51	51

2.6.3 8/12/16V 4000 engine data: Continuous operation, limited 3C, optimized fuel consumption

Explanation:

CP Ref. value: Continuous power (CP)

FSPRef. value: Fuel stop power (FSP)

A Design value

G Guaranteed value

R Guideline value

L Limit value, up to which the engine can be operated, without change (e.g. of power setting)

N Not yet defined value

- Not applicable

X Applicable

REFERENCE CONDITIONS

Engine model			8V	12V	12V	16 V	16 V
			4000 G61	4000 G21	4000 G61	4000 G21	4000 G61
Application group			3C	3C	3C	3C	3C
Intake air temperature		°C	25	25	25	25	25
Charge-air coolant temperature		°C	55	55	55	55	55
Raw water inlet temperature		°C	-	-	-	-	-
Barometric pressure		mbar	1000	1000	1000	1000	1000
Site altitude above sea level		m	100	100	100	100	100

POWER-RELATED DATA (power ratings are net brake power to ISO 3046)

Number of cylinders			8	12	12	16	16
Engine rated speed	A	rpm	1500	1500	1500	1500	1500
Fuel stop power ISO 3046	A	kW	985	1326	1463	1760	1936

GENERAL CONDITIONS (for maximum power)

Number of cylinders			8	12	12	16	16
Intake air depression (new filter) (design)	A	mbar	30	30	30	30	30
Intake air depression (limit value)	L	mbar	50	50	50	50	50
Exhaust backpressure (design)	A	mbar	30	30	30	30	30
Exhaust backpressure (limit value)	L	mbar	51	51	51	51	51

2.6.5 8/12/16V 4000 engine data: Continuous operation, variable 3B, optimized fuel consumption

Explanation:

CP Ref. value: Continuous power (CP)

FSP Ref. value: Fuel stop power (FSP)

A Design value

G Guaranteed value

R Guideline value

L Limit value, up to which the engine can be operated, without change (e.g. of power setting)

N Not yet defined value

- Not applicable

X Applicable

REFERENCE CONDITIONS

Engine model			8V 4000 G61	12V 4000 G21	12V 4000 G61	16 V 4000 G21	16 V 4000 G61
Application group			3B	3B	3B	3B	3B
Intake air temperature		°C	25	25	25	25	25
Charge-air coolant temperature		°C	55	55	55	55	55
Raw water inlet temperature		°C	-	-	-	-	-
Barometric pressure		mbar	1000	1000	1000	1000	1000
Site altitude above sea level		m	100	100	100	100	100

POWER-RELATED DATA (power ratings are net brake power to ISO 3046)

Number of cylinders			8	12	12	16	16
Engine rated speed	A	rpm	1500	1500	1500	1500	1500
Continuous power ISO 3046 (10% overload capability, design power DIN 6280, ISO 8528)	A	kW	895	1205	1330	1600	1760

GENERAL CONDITIONS (for maximum power)

Number of cylinders			8	12	12	16	16
Intake air depression (new filter) (design)	A	mbar	30	30	30	30	30
Intake air depression (limit value)	L	mbar	50	50	50	50	50
Exhaust backpressure (design)	A	mbar	30	30	30	30	30
Exhaust backpressure (limit value)	L	mbar	51	51	51	51	51

2.6.7 8/12/16V 4000 engine data: Continuous operation, variable 3B, optimized exhaust emission (EPA)

Explanation:

CP Ref. value: Continuous power (CP)

FSPRef. value: Fuel stop power (FSP)

A Design value

G Guaranteed value

R Guideline value

L Limit value, up to which the engine can be operated, without change (e.g. of power setting)

N Not yet defined value

- Not applicable

X Applicable

REFERENCE CONDITIONS

Engine model			8V 4000 G81	12V 4000 G81	16 V 4000 G81
Application group			3B	3B	3B
Intake air temperature		°C	25	25	25
Charge-air coolant temperature		°C	55	55	55
Raw water inlet temperature		°C	-	-	-
Barometric pressure		mbar	1000	1000	1000
Site altitude above sea level		m	100	100	100

POWER-RELATED DATA (power ratings are net brake power to ISO 3046)

Number of cylinders			8	12	16
Engine rated speed	A	rpm	1800	1800	1800
Continuous power ISO 3046 (10% overload capability, design power DIN 6280, ISO 8528)	A	kW	1000	1490	1990

GENERAL CONDITIONS (for maximum power)

Number of cylinders			8	12	16
Intake air depression (new filter) (design)	A	mbar	30	30	30
Intake air depression (limit value)	L	mbar	50	50	50
Exhaust backpressure (design)	A	mbar	30	30	30
Exhaust backpressure (limit value)	L	mbar	51	51	51

COOLING SYSTEM (HT circuit)

Number of cylinders			8	12	16
Coolant temperature (at engine outlet to cooling equipment)	A	°C	95	95	95
Coolant temperature after engine, alarm	R	°C	97	97	97
Coolant temperature after engine, shutdown	L	°C	99	99	99
Coolant antifreeze content, max. permissible	L	%	50	50	50
Pressure loss in the external cooling system, max. permissible	L	bar	0.7	0.7	0.7

COOLING SYSTEM (LT circuit)

Number of cylinders			8	12	16
Coolant temperature before intercooler (at engine inlet from cooling equipment)	A	°C	55	55	55
Coolant antifreeze content, max. permissible	L	%	50	50	50
Pressure loss in the external cooling system, max. permissible	L	bar	0.7	0.7	0.7

LUBE OIL SYSTEM

Number of cylinders			8	12	16
Lube oil operating temperature before engine, from	R	°C	85	85	85
Lube oil operating temperature before engine, to	R	°C	95	95	95
Lube oil temperature before engine, alarm	R	°C	95	95	95
Lube oil temperature before engine, shutdown	L	°C	--	--	--
Lube oil operating pressure before engine, from	R	bar	5.0	5.0	5.0
Lube oil operating pressure before engine, to	R	bar	6.0	6.0	6.0
Lube oil pressure before engine, alarm	R	bar	4.5	4.5	4.5
Lube oil pressure before engine, shutdown	L	bar	4.0	4.0	4.0

FUEL SYSTEM

Number of cylinders			8	12	16
Fuel pressure at supply connection to engine (when engine is starting), min. admissible	L	bar	-0.1	-0.1	-0.1
Fuel pressure at supply connection to engine (when engine is starting), max. admissible	L	bar	1.5	1.5	1.5

3.7 Emergency stop

 CAUTION	An emergency stop causes extreme stress to the engine. Risk of overheating, damage to components! <ul style="list-style-type: none"> • Initiate emergency stop only in emergency situations.
---	---

Emergency stop from LOP

Item	Task
EMERGENCY STOP button	Press. <ul style="list-style-type: none"> • Engine is stopped by switching off power supply to ECU; • Signalization (e.g. by horn, flashing lamp) is released.

After emergency stop from LOP

Item	Task
Switching cabinet, control panel etc. (depending on manufacturer)	Press button for alarm acknowledgement. <ul style="list-style-type: none"> • Audible and visual signalization stops.

22,000 to 30,000 operating hours

Item	Limit years	Operating hours [h]																	
		22,000	22,500	23,000	23,500	24,000	24,500	25,000	25,500	26,000	26,500	27,000	27,500	28,000	28,500	29,000	29,500	30,000	
Engine oil filter	2																		
Engine operation	-																		
Centrifugal oil filter	2	X	X	X	X	X	X	X	X	X	X	X	X	X	X	X	X	X	X
Fuel filter	2	X		X		X		X		X		X		X		X		X	
Valve gear	-		X			X			X			X			X			X	
Belt drive	2		X			X			X			X			X			X	
Air filter	3					X						X						X	
Fuel injectors	-		X															X	
Combustion chambers	4		X															X	
Exhaust turbocharger	18																	X	
Component maintenance	18																	X	
Crankcase breather	18																	X	
Cylinder head	18																	X	
Fuel delivery pump	18																	X	
Extended component maintenance	18																	X	

Exhaust gas black

Component	Probable Cause	Task
Air supply	Air filter clogged	Check signal ring position of service indicator (→ Page 6 - 38).
Fuel injection equipment	Injector defective	Replace (→ Page 6 - 18).
Engine	Overloaded	Contact Service.

Exhaust gas blue

Component	Probable Cause	Task
Engine oil	Too much oil in engine	Drain engine oil (→ Page 6 - 40).
	Oil separator of crankcase breather contaminated	Replace (→ Page 6 - 07).
Exhaust turbocharger, cylinder head, piston rings, cylinder liner	Defective	Contact Service.

Exhaust gas white

Component	Probable Cause	Task
Engine	Not at operating temperature	Run engine to reach operating temperature.
Fuel system	Water in fuel	Check fuel system on fuel prefilter. Drain fuel prefilter (→ Page 6 - 29).
Intercooler	Leaking	Contact Service.

Fault code	Alarm text	Meaning	Task
326	WIRING CYLINDER A6	Faulty wiring to solenoid valve cylinder A6; Misfiring	1. Check wiring. 2. Contact Service.
327	WIRING CYLINDER A7	Faulty wiring to solenoid valve cylinder A7; Misfiring	1. Check wiring. 2. Contact Service.
328	WIRING CYLINDER A8	Faulty wiring to solenoid valve cylinder A8; Misfiring	1. Check wiring. 2. Contact Service.
329	WIRING CYLINDER A9	Faulty wiring to solenoid valve cylinder A9; Misfiring	1. Check wiring. 2. Contact Service.
330	WIRING CYLINDER A10	Faulty wiring to solenoid valve cylinder A10; Misfiring	1. Check wiring. 2. Contact Service.
331	WIRING CYLINDER B1	Faulty wiring to solenoid valve cylinder B1; Misfiring	1. Check wiring. 2. Contact Service.
332	WIRING CYLINDER B2	Faulty wiring to solenoid valve cylinder B2; Misfiring	1. Check wiring. 2. Contact Service.
333	WIRING CYLINDER B3	Faulty wiring to solenoid valve cylinder B3; Misfiring	1. Check wiring. 2. Contact Service.
334	WIRING CYLINDER B4	Faulty wiring to solenoid valve cylinder B4; Misfiring	1. Check wiring. 2. Contact Service.
335	WIRING CYLINDER B5	Faulty wiring to solenoid valve cylinder B5; Misfiring	1. Check wiring. 2. Contact Service.
336	WIRING CYLINDER B6	Faulty wiring to solenoid valve cylinder B6; Misfiring	1. Check wiring. 2. Contact Service.
337	WIRING CYLINDER B7	Faulty wiring to solenoid valve cylinder B7; Misfiring	1. Check wiring. 2. Contact Service.
338	WIRING CYLINDER B8	Faulty wiring to solenoid valve cylinder B8; Misfiring	1. Check wiring. 2. Contact Service.
339	WIRING CYLINDER B9	Faulty wiring to solenoid valve cylinder B9; Misfiring	1. Check wiring. 2. Contact Service.

6.2.2 Instructions and comments on endoscopic and visual examination of cylinder liners

Terms used for endoscopic examination

Use the terms listed below to describe the condition of the cylinder-liner surface in the endoscopic examination report.

Minor dirt scores	Light scoring can take place during the assembly of a new engine (honing products, particles, broken-off burrs). Removed cylinders clearly show such scoring on the running surface under endoscope magnification. Cannot be felt with the fingernail. Findings not critical.
Single scores	Clearly visible scores from hard particles. They usually start in the TDC area and cross through the hone pattern in the direction of stroke. Findings not critical.
Scored area	These areas consist of scores of different length and depth next to one another. In most cases, they are found at the 6-o'clock and 12-o'clock positions (inlet/exhaust) along the transverse engine axis. Findings not critical.
Smoothened area	Smoothened areas are on the running surface but almost the whole honing pattern is still visible. Smoothened areas appear brighter and more brilliant than the surrounding running surface. Findings not critical.
Polished area	Polished areas are on the running surface and show local removal of the honing pattern. Grooves from honing process are not visible any more.
Discoloration	This is caused by oxidation (surface discoloration through oil or fuel) and temperature differences around the liner. It appears rather darker within the honed structure in contrast to the bright metallic running surface. The honing pattern is undisturbed. Discolorations extend in stroke direction and may be interrupted. Findings not critical.
Corrosion fields / spots	Corrosion fields / spots result from water (condensed water) with the valves in the overlap (open) position. They are clearly visible due to the dark color of the honing groove bottom. This corrosion is not critical unless there are corrosion pittings.
Black lines	Black lines are a step towards heat discoloration. They are visible as a clear discoloration from TDC to BDC in the running surface and the start of localized damage to the honing pattern. Cylinders with a number of black lines around the running surface have limited service life and should be replaced.
Discolorations (Heat)	These are caused by a disturbance in the liner / ring tribosystem. Usually they run over the whole ring-travel area (TDC/BDC), starting at the first TDC-ring and becoming more visible from the second TDC-ring onwards and less pronounced from TDC-ring 1. The honing pattern is usually no longer visible and displays a clearly defined (straight) edge to the undisturbed surface. The damaged surface is usually discolored. The circumferential length varies. Liners with heat discoloration starting in the TDC-ring 1 have to be replaced.
Seizures, Seizure marks	Irregular circumference lengths and depths. Can be caused by either the piston skirt or the piston crown. Material deposits on the liner (smear), heavy discoloration. Severe, visible scoring. Replace liner.

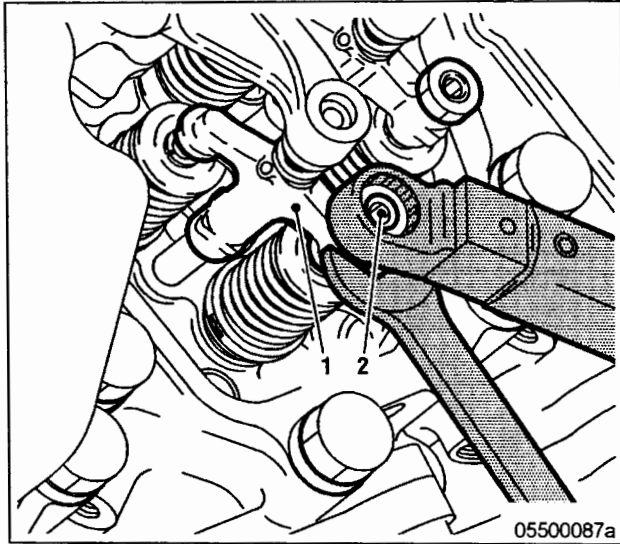

7. Tighten locknut (2) to 35 Nm +5 Nm, holding valve bridge (1) in position with open-end spanner.
8. Check valve bridge balance again.

CLICK HERE TO **DOWNLOAD** THE COMPLETE MANUAL

- Thank you very much for reading the preview of the manual.
- You can download the complete manual from: www.heydownloads.com by clicking the link below



- Please note: If there is no response to CLICKING the link, please download this PDF first and then click on it.

CLICK HERE TO **DOWNLOAD** THE COMPLETE MANUAL

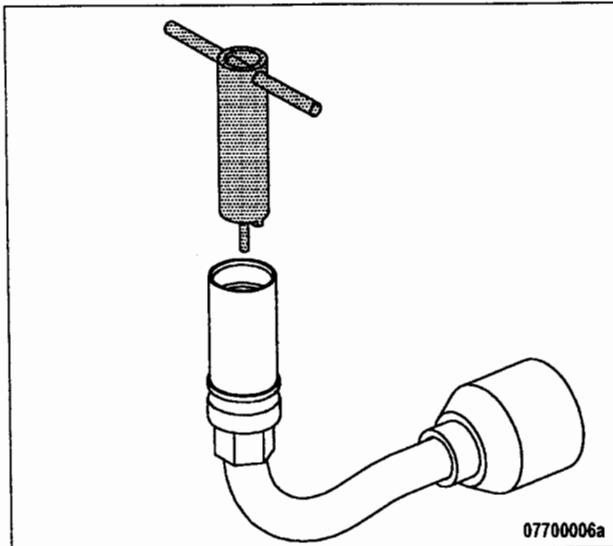

11. Use slotted screwdriver to check thrust ring at both line ends for secure seating.
12. Tighten loose thrust ring to 10 Nm.

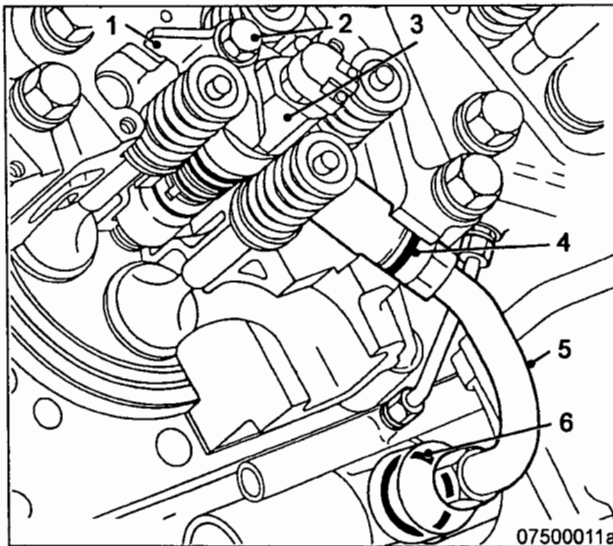

13. Fit hold-down clamp (1) in correct position and install screw (2) by hand.
14. Tighten screw (2) with torque wrench, preliminary tightening torque: 5 Nm to 10 Nm.
15. Coat new O-rings (4) and (6) on with petroleum jelly and fit on HP fuel line (5).
16. Install HP line (5) and tighten preliminarily, tightening torque: 5 Nm to 10 Nm.
17. Tighten screw (2) to 100 +10 Nm.
18. Tighten HP fuel line to 120 Nm +12 Nm.

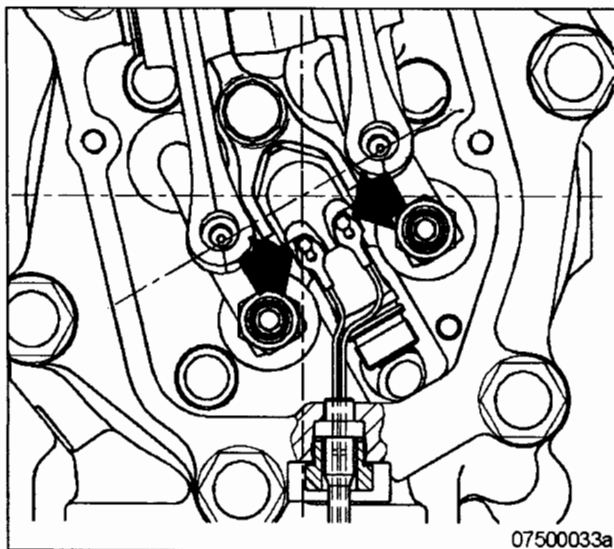

19. Fit cable terminals below the screws on injector and tighten to 1 Nm.

6.8.6 Fuel prefilter – filter element replacement

Preconditions

- Engine is stopped and starting disabled.

Material

Designation / Use	Part No.	Qty.
Diesel fuel		

Spare parts

Designation / Use	Part No.	Qty.
Filter element		
Gasket		



Fuels are combustible.

Risk of fire and explosion!

- Avoid naked flames, electrical sparks and ignition sources.
- Do not smoke.

6.14 Oil Filtration / Cooling

6.14.1 Engine oil filter – Replacement

Preconditions

- Engine is stopped and starting disabled.

Special tools

Designation / Use	Part No.	Qty.
Oil filter wrench		

Material

Designation / Use	Part No.	Qty.
Engine oil		

Spare parts

Designation / Use	Part No.	Qty.
Oil filter		



WARNING

Hot oil.

Oil can contain combustion residues which are harmful to health.

Risk of injury and poisoning!

- Wear protective clothing, gloves, and goggles / safety mask.
- Avoid contact with skin.
- Do not inhale oil vapor.

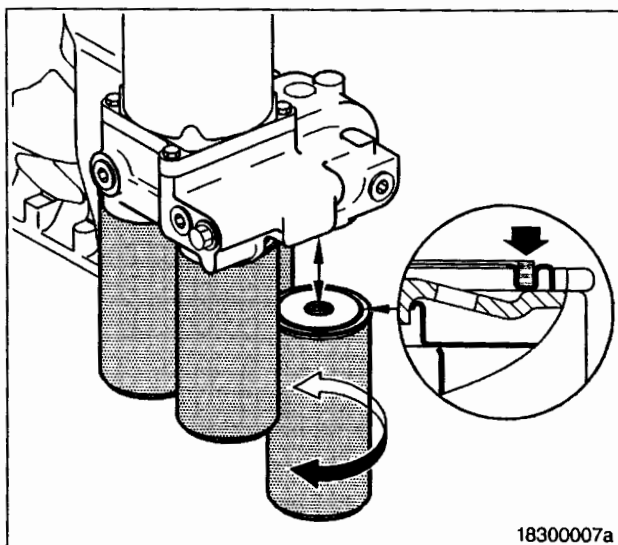

Engine oil filter – Replacement

1. Unscrew oil filter with oil filter wrench.
2. Clean the sealing surface of the filter head.
3. Check condition of the new sealing ring and coat it with oil.
4. Screw on and tighten new oil filter by hand.
5. Replace further oil filters in the same way.
6. Crank the engine with the starting device after each oil change and each filter replacement (→ Page 6-02).
7. Check oil level (→ Page 6-42).

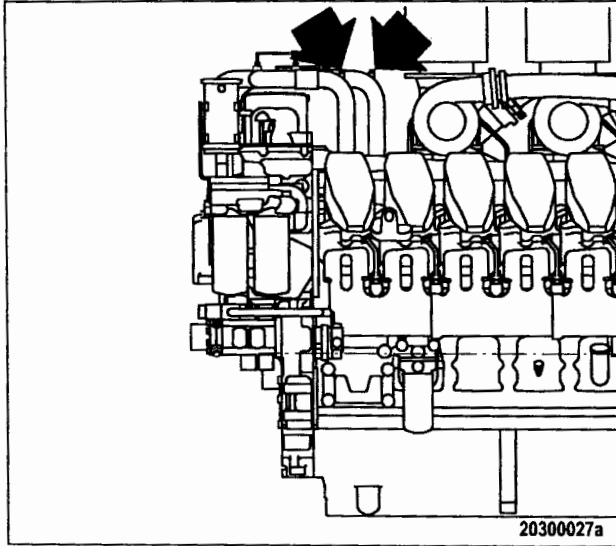
**Charge-air coolant filling**

1. Pour treated coolant via the filling points on the coolant lines from and to the intercooler and via the filler neck of the expansion tank until coolant is visible at the marking plate.
2. Install plugs with new sealing rings at the filling points.
3. Check proper condition of breather valve, clean sealing faces if required.
4. Fit breather valve onto filler neck and close it.

Final steps

1. Start the engine and operate it at idle speed for some minutes.
2. Check coolant level (→ Page 6 – 56).

6.20 General Wiring, Engine / Gearbox / Plant

6.20.1 Engine wiring check

Preconditions

- Engine is stopped and starting disabled.

Material

Designation / Use	Part No.	Qty.
Isopropyl alcohol		

Engine wiring check

1. Check securing screws of cable clamps on the engine and tighten loose screw connections.
2. Make certain that cables are securely seated in clamps and cannot move freely.
3. Check cable binders for secure seating, tighten loose cable binders.
4. Replace defective cable binders.
5. Inspect electrical components visually for damage:
 - connector housings;
 - contacts;
 - connector sockets;
 - cables and terminals;
 - plug-in contacts.
6. If conductors are damaged, contact Service.
7. Clean dirty connector housings, sockets and contacts with isopropyl alcohol.





Abbreviation	Meaning	Explanation
SEL	Stop Engine Light	1st function: Warning lamp (stop engine and rectify fault) 2nd function: Read out fault codes
SID	System Identifier	
SPC	Spare Parts Catalog	
SRS	Synchronous Reference Sensor	TDC cylinder 1
SS	Safety System	Indicated alarm is initiated by the safety system
TBS	Turbocharger Boost Sensor	Monitors charge-air pressure
TC	Tools Catalog	
TCI	Turbo Compressor Inlet	
TCO	Turbo Compressor Outlet	
TD	Transmitter Deviation	Alarm: Sensor-comparison failure
TPS	Throttle Position Sensor	
TRS	Timing Reference Sensor	
T-xyz	Temperature-xyz	Temperature measuring point xyz
UT	Unterer Totpunkt	Bottom dead center (BDC)
VNT	Variable nozzle turbine	
VSG	Variable Speed Governor	
VSS	Vehicle Speed Sensor	

Tool List
Werkzeugliste



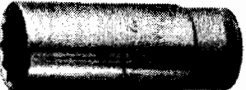
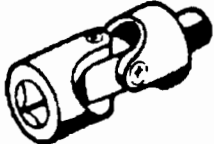

MTU
Diesel Engine
Series 4000

Réf. constructeur : M004029/31DE

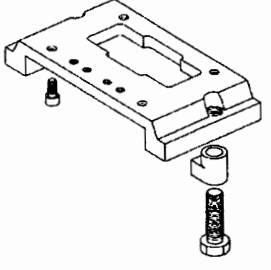
Réf. GPAO : 33519005201 ind1

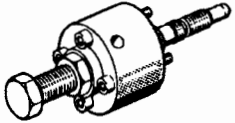
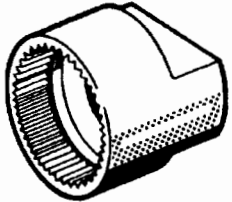
Oz	Sach-Nr. Part Number	Benennung Designation	Stück Qty	Verwendung / Used for Abmessung / Size	Seite/Page 14 von/of 95
	► F3 0004 939	STECKSCHLUESSELEINS. WRENCH SOCKET	1	SW 13, 1/2" 13 A/F, 1/2" sq.	
	► F3 0005 546	EINMAULSCHLUESSEL OPEN-END WRENCH	1	SW 46 open jaw, 46mm	
	► F3 0006 068	DOPPELMAULSCHLUESSEL D.E. OPEN-JAW WRENCH	1	SW 55x60 open jaw DE, 55 – 60mm	
	► F3 0006 120	STECKSCHLUESSELEINS. SOCKET ADAPTER	1	SW 32 1/2" lang, Oel- Drucksensor 32mm, 1/2" sq. dr. ED, clnt level and oil press. sensors	
	► F3 0006 202	KARDANGELENK UNIVERSAL JOINT	1	1/2" 1/2" sq.	
	► F3 0006 211	KNARRE RATCHET	1	1/2" 1/2" sq.	

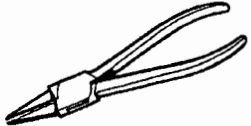

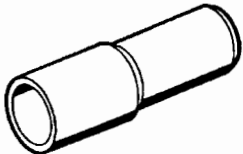
Oz	Sach-Nr. Part Number	Benennung Designation	Stück Qty	Verwendung / Used for Abmessung / Size	Seite/Page 24 von/of 95
	F6 558 528	ADAPTER ADAPTER	1	f. Durchdrehvorr. von unten ansetzen, Truck- Mot. application from below; truck engine	

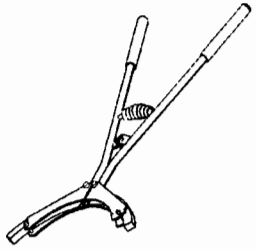
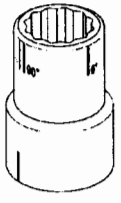
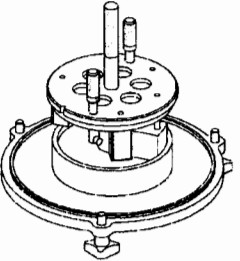
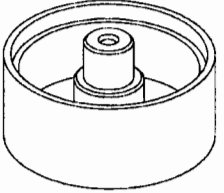
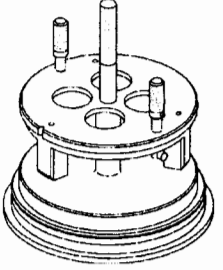
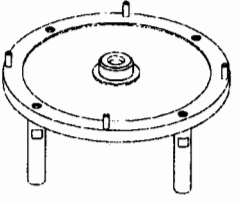

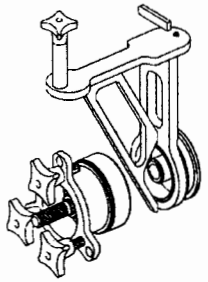
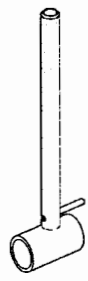
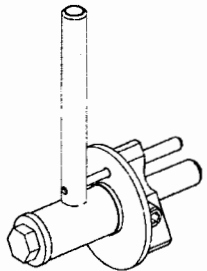
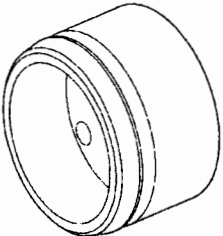
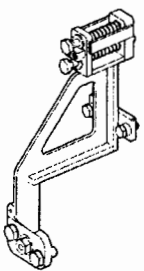

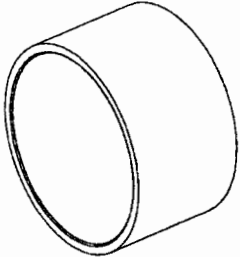
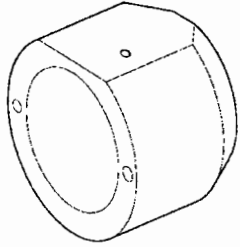
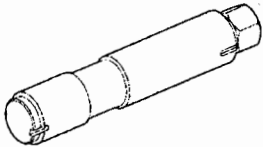
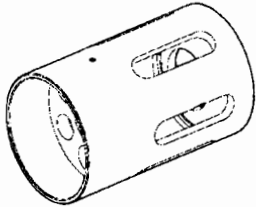
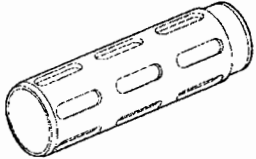
Oz	Sach-Nr. Part Number	Benennung Designation	Stück Qty	Verwendung / Used for Abmessung / Size	Seite/Page 34 von/of 95
	550 589 03 33/00	MONTAGEVORRICHTUNG INST/REMOVAL JIG	1	zur Montage und Demontage von Lenzpumpe 550 200 32 01 für Laufrad For installing/removing the impeller of bilge pump (550 200 32 01).	
	550 589 05 31/00	FESTHALTEVORRICHTUNG RETAINING FIXTURE	1	zur Montage und Demontage von Lenzpumpe 550 200 32 01 für Kupplungsteil For installing/removing the coupling of bilge pump (550 200 32 01).	
	F3 0002 754	ZANGEN F. SICH.RINGE CIRCLIP PLIERS	1	Lenzpumpe 5270040120 montieren, für Sicherungsring For installation of retaining ring in bilge pump (527 004 01 20)	
	F3 0002 760	ZANGEN F. SICH.RINGE CIRCLIP PLIERS	1	zur Montage und Demontage von Lenzpumpe 550 200 32 01 für Sicherungsring Tools for (dis)assembling bilge pump 550 200 32 01 for retaining ring	
	F3 0024 425	STECKSCHLUESSELEINS. SOCKET	1	zur Montage und Demontage von Lenzpumpe 550 200 32 01 SW 24 Tools for (dis)assembling bilge pump 550 200 32 01, 24mm	
	F3 0140 768	EINSCHLAGHUELSE DRIVE-IN SLEEVE	1	zur Montage und Demontage von Lenzpumpe 550 200 32 01 für Kugellager Tools for (dis)assembling bilge pump 550 200 32 01 for ball bearing	

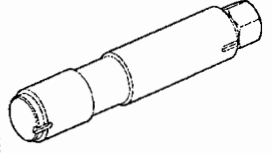
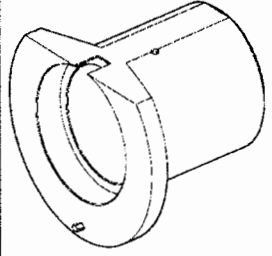
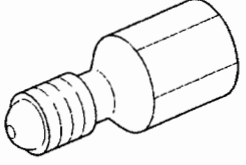
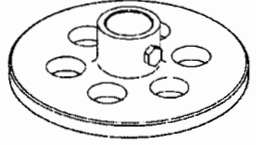
Oz	Sach-Nr. Part Number	Benennung Designation	Stück Qty	Verwendung / Used for Abmessung / Size	Seite/Page 44 von/of 95
	F3 0378 003	KOLBENRINGZANGE PISTON RING PLIERS	1		
	F3 0378 352	STECKSCHLUESSELEINS. SOCKET ADAPTER	1	SW 22 - Pleuelschrauben piston removal	
	F3 0378 425	ZB.EINFUEHRWERKZEUG INSTALLATION JIG <i>dazu / plus</i> +	1	KW-Lager Geräteträger main bearings in equip. carrier; also req'd:	
+ F6 557 152		FIXIERVORRICHTUNG LOCATING JIG	1	KW-Lager main bearing	
	F3 0378 426	ZB.EINFUEHRWERKZEUG INSTALLATION JIG <i>dazu / plus</i> +	1	KW-Lager Schwungradgehäuse main bearing in F/wheel hsng; also req'd:	
+ F6 557 153		FIXIERVORRICHTUNG LOCATING JIG	1	KW-Lager main bearing	

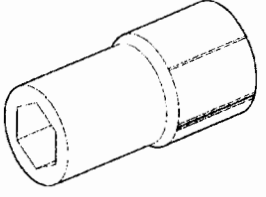
Oz	Sach-Nr. Part Number	Benennung Designation	Stück Qty	Verwendung / Used for Abmessung / Size	Seite/Page 54 von/of 95
	F6 555 738	MONTAGEVORRICHTUNG ASSEMBLY FIXTURE <i>dazu / plus</i> +	1	8V - 20V Motor Nockenwellenlager einbauen 8V - 20V Engine Camshaft bearing installation device; also required:	
	+ F3 0377 671	HALTER RETAINER	1	für Schrumpfwerkzeug Camshaft installation/removal shoe	
	+ F3 0377 672	SCHRUMPFWERKZEUG SHRINKAGE TOOL	1	Nockenwellenlager Camshaft bearing	
	+ F6 555 763	FUEHRUNGSBUCHSE GUIDE BUSHING	1	NW-lager auf Schrumpfwerkzeug aufschieben mounting camshaft bearing to compressor	
	F6 781 643	AUSRICHTVORRICHTUNG ALIGNMENT FIXTURE	1	20 V 4000 Nockenwelle 5280500101 zur KW 5280300101 ausrichten für Nockenwellenrad aufpressen Align 20V 4000 camshaft 5280500101 to crankshaft 5280300101, to press camshaft into place	

Oz	Sach-Nr. Part Number	Benennung Designation	Stück Qty	Verwendung / Used for Abmessung / Size	Seite/Page 64 von/of 95
	► F6 554 706	DISTANZBUCHSE SPACER SLEEVE	1		
	► F6 782 016	DRUCKBUCHSE THRUST BUSH	1		
	► F6 782 017	ZUGSPINDEL DRAW SPINDLE	1		
	+ F6 780 591	FUEHRUNGSHUELSE GUIDE SLEEVE <i>zusätzlich zu besteht aus / plus consists of</i>	1	12V-16V für Schwingungsdämpfer und Mitnehmerflansch 12/16V for vibration damper and follower flange	
	+ F6 781 745	FUEHRUNGSHUELSE GUIDE SLEEVE <i>zusätzlich zu besteht aus / plus consists of</i>	1	verlängert die Führungshülse F6 780 591 um die Ölkühlerlänge Extends the guide sleeve F6 780 591 by the length of the oil cooler	

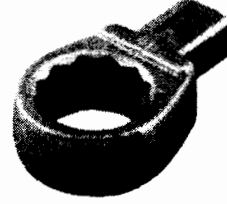
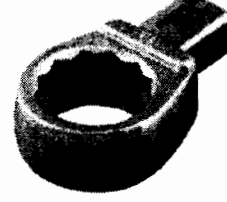
Oz	Sach-Nr. Part Number	Benennung Designation	Stück Qty	Verwendung / Used for Abmessung / Size	Seite/Page 74 von/of 95
	► F6 782 017	ZUGSPINDEL DRAW SPINDLE	1		
	► F6 782 018	DRUCKBUCHSE THRUST BUSH	1		
	+ F6 374 261	REDUZIERSTUECK ADAPTER <i>zusätzlich zu besteht aus / plus consists of</i>	2	R1/4" X R1/4" Nicht im ZB beinhaltet! R1/4"x R1/4"	
	F3 0377 680	EINPRESSWERKZEUG PRESS-IN TOOL	1	für Radialdichtring in DR- Halter KGS for radial seal in DR bracket, non-drive end	
	F3 0379 300	JUSTIERDORN ADJUSTING MANDREL	2	Schwingungsdämpfer Vibration damper	
	F3 0379 767	STECKSCHLUESSELEINS. SOCKET ADAPTER	1	SW 24 60°-65°, 3/4" Schrauben Pos.750 von Kupplung 527 000 03 25 mit Verdrehwinkel anziehen 24mm 60-65°, 3/4"; tighten screws, Item 750 of coupling 527 000 03 25 to angle of rotation	

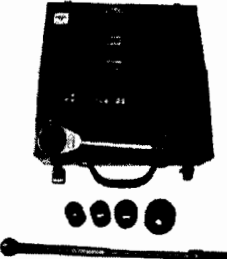
Oz	Sach-Nr. Part Number	Benennung Designation	Stück Qty	Verwendung / Used for Abmessung / Size	Seite/Page 84 von/of 95
	F3 0030 767	RING-EINSTECKWERKZEU RING WRENCH ADAPTER	1	SW 32, 14x18 f. Centalink- Kuppl. CL71 32mm, 14x18 for Centalink CL71 coupling	
	F3 0039 520	RINGEINSTECKSCHLUESS RING WRENCH ADAPTER	1	SW 14, 14 x 18 14mm, 14 x 18	
	F3 0039 526	RINGEINSTECKSCHL. RING WRENCH ADAPTER	1	SW 24, 14x18 f. Ventilbrücke 24mm, 14x18 for valve bridge	
	F3 0039 528	EINSTECK-RINGSCHL. RING WRENCH ADAPTER	1	SW 30, 14x18 f. Centalink- Kuppl. CL71 30mm, 14x18 for Centalink CL71 coupling.	
	F3 0047 798	DREHMOMENTSCHLUESSEL TORQUE WRENCH	1	300 - 800 Nm, 14 X 18 VKT 300 - 800 Nm, 14 x 18	
	F3 0378 843	WERKZEUGSATZ TOOL KIT	1	Hand-Kraftvervielfältiger f. 730Nm Centalinkkup. manual power amplifier for 730Nm Centalink coupling.	

CLICK HERE TO **DOWNLOAD** THE COMPLETE MANUAL

- Thank you very much for reading the preview of the manual.
- You can download the complete manual from: www.heydownloads.com by clicking the link below



- Please note: If there is no response to CLICKING the link, please download this PDF first and then click on it.

CLICK HERE TO **DOWNLOAD** THE COMPLETE MANUAL