

# ***Temis***

**USER AND  
MAINTENANCE MANUAL**

CLICK HERE TO **DOWNLOAD** THE COMPLETE MANUAL

- Thank you very much for reading the preview of the manual.
- You can download the complete manual from: [www.heydownloads.com](http://www.heydownloads.com) by clicking the link below



- Please note: If there is no response to CLICKING the link, please download this PDF first and then click on it.

CLICK HERE TO **DOWNLOAD** THE COMPLETE MANUAL



## A.3 - SAFETY

### A.3.1 - FOREWORD



*This text is of a general nature. Some paragraphs may not apply to your tractor.*

- RENAULT Tractors are **designed and built to give you the best service** for many years. They are designed to provide comfortable and **safe working conditions**.

However, **accidents can easily happen** in agricultural work. It is important to know the dangers and **how to avoid them**.

**WE WOULD LIKE TO DRAW YOUR ATTENTION TO A FEW POINTS WHICH DESERVE EXTRA SPECIAL CARE\***.

### A.3.2 - PRECAUTIONS BEFORE STARTING

- **Caution** is the best guarantee against any risk of accident.
- The driver must be **fully familiar with the tractor** and must understand all the controls, their position and their purpose. It is **essential to read this manual carefully**.
- If the tractor is used by **anybody other** than the owner, he must be **given** all explanations required to allow him to operate the tractor **safely**.
- The driving position must be **clean** (instrument panel, steering wheel, floor and pedals).
- **STEPS MUST BE CLEAN** (free of mud) to avoid slipping when getting in or out of the tractor.

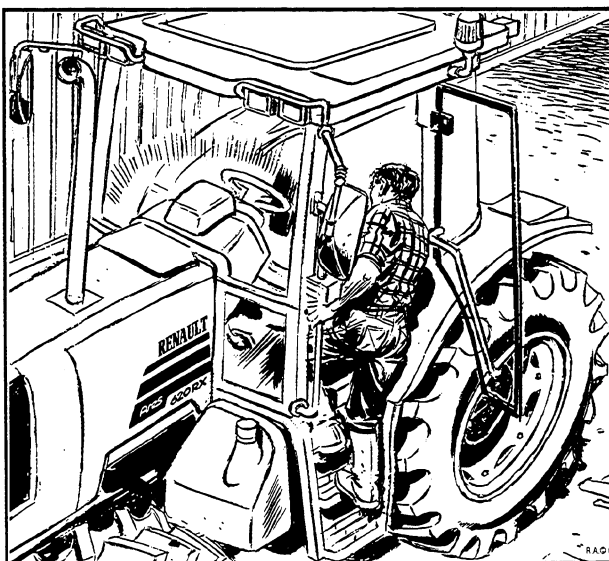

A009

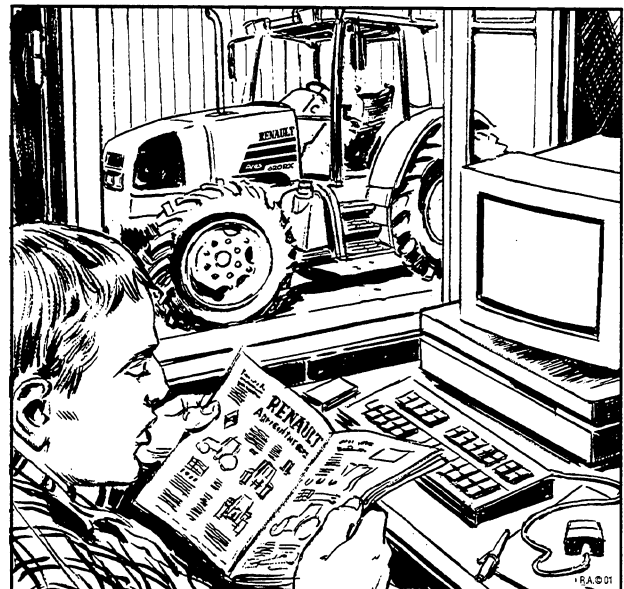

A008

- **Use the steps and handles** provided when getting into or out of the tractor.
- Before starting the engine, make sure that all controls are in the **neutral position**, particularly the power take-off lever.
- Run the engine only in **WELL-VENTILATED** areas.
- Make sure there is nobody nearby before starting the tractor.
- **Completely release the handbrake** before moving off.
- Do not start work if the tractor is not working properly.

*\* This is not an exhaustive list.*



## B.1 - CONTROLS AND INSTRUMENTS (driver's cab)

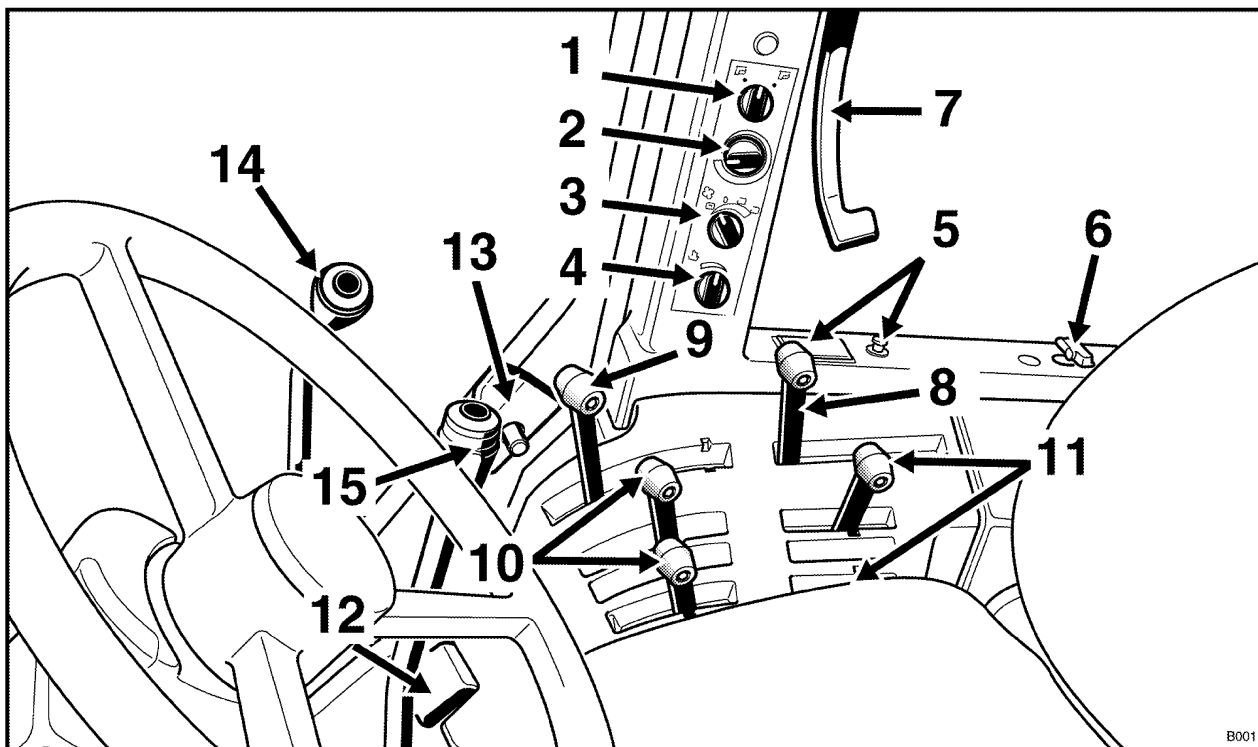

- 1 - Recycling button \*.
- 2 - Air-conditioning system adjustments and On / Off button \*.
- 3 - Air flow adjustment.
- 4 - Heating temperature adjustment.
- 5 - Ashtray with cigarette lighter.
- 6 - 25A connector for connection of electronic toolbox.
- 7 - Side window opening and locking handle.
- 8 - Lifting control level (position display)
- 9 - Lifting control level (draft control)
- 10 - Auxiliary distribution levers (positions 1 and 2).
- 11 - Auxiliary distribution levers (positions 3 and 4).
- 12 - Door open unlocking handle, for closing.
- 13 - Door unlocking pushbutton.
- 14 - Range shift lever.
- 15 - Gear shift lever.

\* If fitted

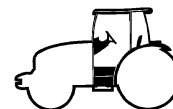

## B.7.2 - PNEUMATIC SEAT \*

- 1 Longitudinal adjustment.  
Actuate the operating handle to free the lock for back and front adjustment.
- 2 Horizontal shock absorber.  
To be used in order to absorb longitudinal accelerations due to the use of the tractor on the road and generally any work at over 7 km/h.
- 3 Weight adjustment.  
Pull the weight adjustment handle once. Wait until the adjustment has been effected. Then, move this handle either up or down in order to adjust the height of the seat. It is necessary to repeat this operation for every driver
- 4 Adjustment of the slope of the back squab of seat.
- 5 Adjustment of the slope of the seat armrests.
- 6 Lumbar adjustment.  
Turn the handle to the left or to the right for moving the lumbar support to a higher or a lower position.
- 7 - Headrest, adjustable.
- 8 - Adjustment of sitting position to be higher or lower.
- 9 - Adjustment of the slope of sitting position.

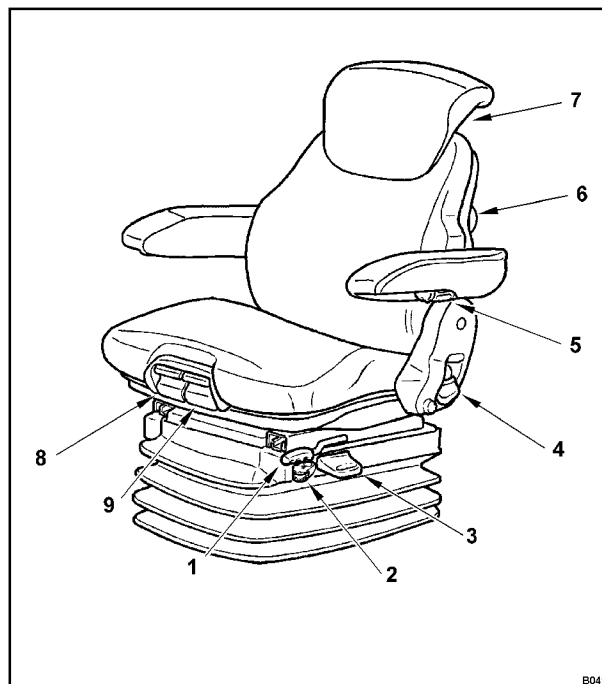

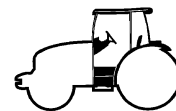

Every  
3 years

## ROUTINE MAINTENANCE

Operations to be carried out  
every 3 years



### AIR CONDITIONING \*

#### DRIER

- Have the drier replaced by your RENAULT agriculture approved repairer.

**IMPORTANT:** The circuit must never be opened (compressor screw, pipework) as this causes all the refrigerant to be lost.

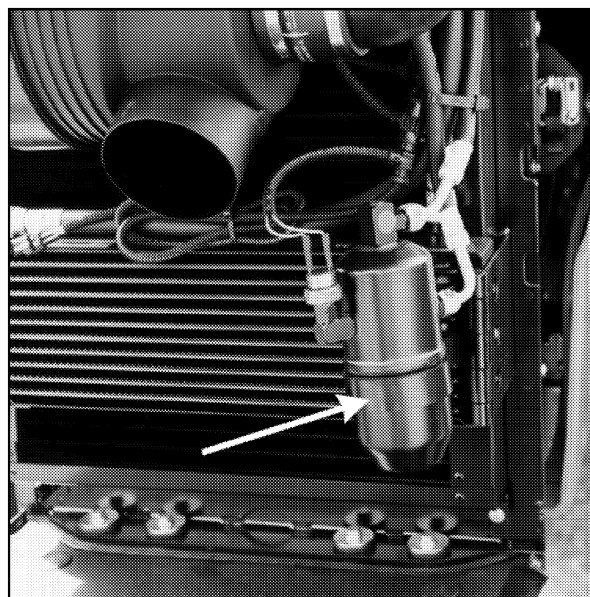

B071



**SAFETY:** If there is a leak, you must wear protective goggles. Refrigerant gas and liquid are dangerous to the eyes.

\* If fitted



## C.2 - MAINTENANCE

### C.2.1 - GENERAL

Knowledge and skill are required to work on the electrical system.

Call in your RENAULT Agriculture agent whenever necessary (to install accessories, a radio, a CB, etc.).

Also:

- Never "patch-up" electric circuits.
- Never replace a blown fuse by a larger fuse: **you could cause a fire.**
- Never work on, for example, the alternator or the fan motor when the engine is running.
- Always disconnect the battery **negative terminal** before working on the electrical circuit.

Finally, if you use a high-pressure washer to clean the tractor, take care not to damage the connections on the various electrical looms.

### C.2.2 - ELECTRIC WELDING

**IMPORTANT:** All forms of electric welding (spot or arc) can damage your tractor's electrical and electronic equipment. You are therefore **strongly advised not to do any welding on the tractor (or even on an implement coupled to the tractor).**

*Note:* For electric welding on the tractor, call the RENAULT Agriculture network.

### C.2.3 - ROUTINE MAINTENANCE

The user can carry out maintenance which **requires no particular professional skills** provided he complies with the maintenance frequencies and instructions given in this manual.

### C.2.4 - FAILURES OR MALFUNCTIONS

- If the tractor suffers a failure.
- Or a malfunction.

Call in your **RENAULT Agriculture agent**. He is the only person with the skills required to efficiently repair your tractor.

You should also call him in if simple adjustments you carry out yourself do not give the required results.

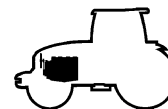

**a) Working at intermediate loads.**

- If, during a particular job, you notice that the engine speed is always **above the rated speed and varies little**, the engine is underloaded and the land is uniform.

In this case, you can **economize** by selecting a higher gear and reducing the engine speed.

**b) Full-load working**

The engine torque curve ensures it can absorb large variations in load without stalling. Select the best gear (depending on the tool and the work) and set the accelerator lever to maximum: the engine speed should be close to the rated value of 2350 rpm TEMIS 550.

- If the **force required drops briefly**, the speed will rise to between the rated speed and the max off-load speed (+ 200 rpm).
- During these **brief increases in load**, the engine can absorb the overload without any problem since the max torque occurs at 1400 rpm. **However, you must not constantly work on overload.** If the engine speed drops to the **max-torque speed too frequently, change your working conditions** (forward speed, working depth, number of shares, etc.) to allow the engine to run at near its rated speed.

## **FUEL**

### **General**

A diesel engine injection system, particularly the injection pump, includes moving parts with a clearance of approx 1 micron.

Any foreign matter, even if measuring only a few microns, is enough to cause serious damage.

Consequently, the fuel must always be perfectly clean and free of any solid particles.

Moreover, it must contain no water since this will inevitably cause problems with the operation of the engine and serious corrosion in the injection system.

### **Filling with fuel (precautions)**

- It is advisable to filter the fuel and fill the tank in the evening, to avoid condensation.

**CAUTION:** The fuel tank cap includes a vent valve or orifice. A faulty valve or clogged hole will lead to a poor fuel supply to the engine, causing incorrect operation, and can distort the tank.

### **Fuel storage precautions**

- Never draw fuel from a drum immediately after handling it.
- Correctly stored fuel remains perfectly clean.
- We recommend the use of a sediment bowl.

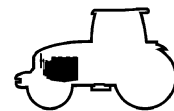

Every  
**500 h**  
or  
yearly

## ROUTINE MAINTENANCE

Operations to be carried out  
every **500 h** or yearly



### FUEL FILTER

- To replace fuel filters:

- 1 - Loosen the bowl (A).
- 2 - Clean the bowl.
- 3 - Fit the new filter.
- 4 - Put the bowl back.

**CAUTION:** After the change of the fuel filter, purge the filter (see purging of the fuel circuit in the present chapter).

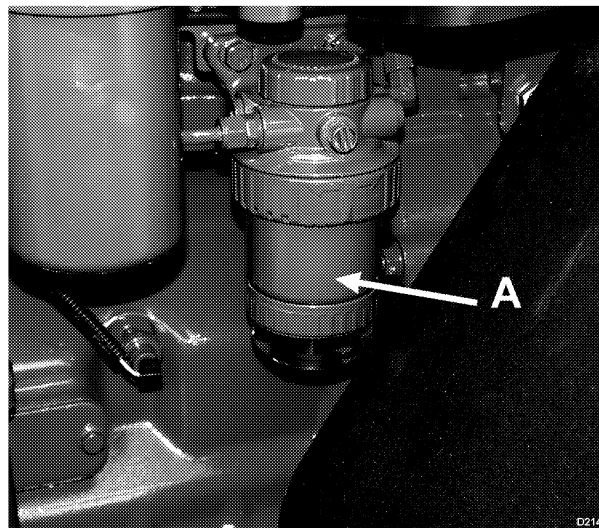

D214

There is a filter (D) which is located between the tank and the injection pump.

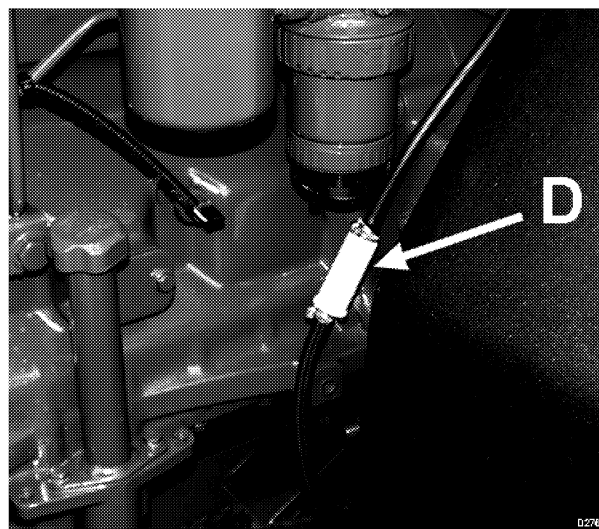

D276

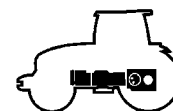

# E - TRANSMISSION

## CONTENTS

<b>E.1 - CHARACTERISTICS .....</b>	<b>E.77</b>
E.1.1 - GEARBOX .....	E.77
E.1.2 - REAR AXLES .....	E.78
E.1.3 - TEMIS MECHANICAL GEARBOX CLUTCHES .....	E.79
E.1.4 - BRAKES .....	E.79
E.1.5 - REAR POWER TAKE-OFF .....	E.80
<b>E.2 - OPERATING INSTRUCTIONS .....</b>	<b>E.81</b>
<b>E.3 - PRESENTATION OF TRACTONIC GEARBOX .....</b>	<b>E.83</b>
<b>E.4 - DESCRIPTION .....</b>	<b>E.84</b>
E.4.1 - DRIVING STATION .....	E.84
E.4.2 - INDICATORS .....	E.84
E.4.3 - USE .....	E.85
E.4.4 - POWERING .....	E.85
E.4.5 - ENGINE STARTING .....	E.85
<b>E.5 - OPERATING THE ELECTRO-HYDRAULIC CONTROLS IN AUTOMATIC     REVERSING GEAR MODE WITH THE SHIFTING TRIPLER .....</b>	<b>E.87</b>
E.5.1 - REVERSAL OPERATION (IN AUTOMATIC REVERSING GEAR / TRIPLER MODE) .....	E.88
E.5.2 - TRIPLER BUTTONS (D) .....	E.89
<b>E.6 - OPERATION OF THE ELECTRO-HYDRAULIC CONTROLS IN REVERSING     GEAR AND AUTOMATIC BRAKING MODE .....</b>	<b>E.90</b>
E.6.1 - REVERSE OPERATION (IN REVERSING GEAR AND AUTOMATIC BRAKING MODE) .....	E.91
E.6.2 - REVERSAL OF THE RUNNING DIRECTION .....	E.92
E.6.3 - REAR AXLE DIFFERENTIAL .....	E.94
<b>E.7 - REAR PTO .....</b>	<b>E.95</b>
E.7.1 - STARTING SAFETY .....	E.95
E.7.2 - START-UP .....	E.95
E.7.3 - RESTART PROCEDURE .....	E.95
E.7.4 - REAR PTO .....	E.97
<b>E.8 - RUNNING SPEED TABLE .....</b>	<b>E.98</b>

CLICK HERE TO **DOWNLOAD** THE COMPLETE MANUAL

- Thank you very much for reading the preview of the manual.
- You can download the complete manual from: [www.heydownloads.com](http://www.heydownloads.com) by clicking the link below



- Please note: If there is no response to CLICKING the link, please download this PDF first and then click on it.

CLICK HERE TO **DOWNLOAD** THE COMPLETE MANUAL

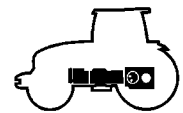

**E.4.3 - USE**

When the tractor is started, the priority mode is **Automatic Reversing gear / Tripler**. If you want to work in **Reversing gear and Automatic Braking mode**, refer to the access procedure on page E.90.

**E.4.4 - POWERING**

- Turn the ignition key to the right to position (I).
- All indicators come on for **3 seconds** so that the driver can check that they operate correctly.
- **After 3 seconds:**  
All indicators go out, except indicator (5) and one of the first 4 indicators \*.

- \* { (5) → No pressure (engine stopped)
- (1) - (2) - (3) - (4)  
→ Status of the automatic reversing gear / tripler when the ignition was cut (last time engine stopped)

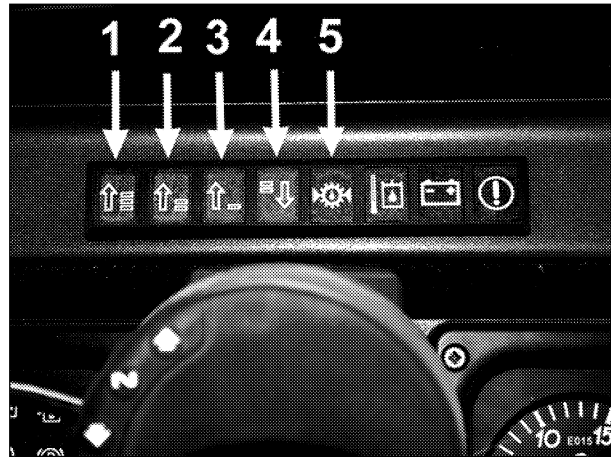
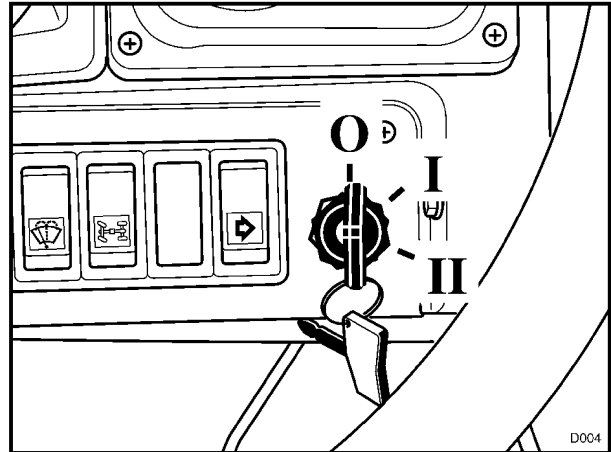

**E.4.5 - ENGINE STARTING**

(See page D.54 of the User's Manual)

**IMPORTANT:** gear levers (A) and speed selection levers (E) must be in neutral. A security system stops starting when a gear is engaged.

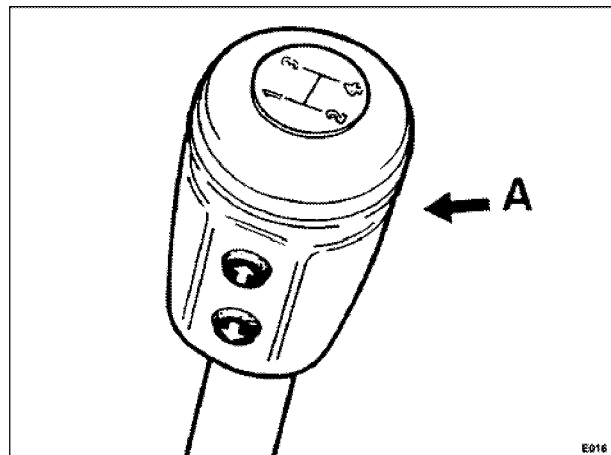

**\*\*CAUTION:** Tractor with progressive system. Only the top neutral point enables starting in position (E).  
When the engine runs, indicator (5) goes out.

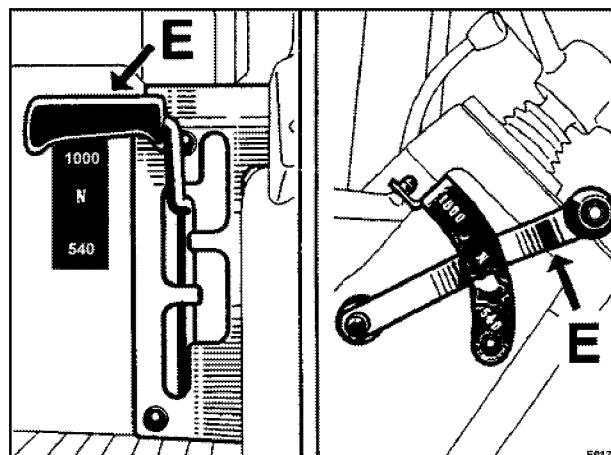

Standard Cab \*\*

Hydrostable Cab

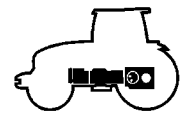

## E.7 - REAR PTO

The PTO clutch control of your tractor is hydraulically powered.

### E.7.1 - STARTING SAFETY

To start the tractor, PTO speed selector lever (1) must be in neutral.

Any position other than the one corresponding to neutral stops the engine from being started.

#### TRACTOR WITH PROPORTIONAL PTO

**CAUTION:** The tractor can only be started when in top neutral point position.

### E.7.2 - START-UP

- Start the engine, then switch it to idle speed.
- Position clutch control lever (2) in position A. The PTO clutch is de-clutched.
- Now select the required PTO speed using lever (1), 540 or 1,000 rpm or proportional \*.
- Gradually return lever 2 to initial clutch position B. Indicator (4) comes on and the PTO rotates.

**PRECAUTIONS:** Leave lever (2) in de-clutched position for the time required to carry out the operation. If you are not going to use the PTO, put lever (1) in neutral and return lever (2) to clutched position B. Indicator (4) goes out.

**IMPORTANT:** Some work with the PTO may, in certain difficult cases, cause the engine to stall. In this case, the implement is blocked and does not rotate. The PTO shaft is under pressure and it is not possible to put lever (1) back in neutral. Under these conditions, the engine cannot be restarted (starting safety).

### E.7.3 - RESTART PROCEDURE

- Press pushbutton (3) and at the same time operate the ignition to briefly activate (5) the starter.

**Note:** one or more brief impulses release the pressure on the PTO shaft and make it possible to turn the lever to neutral.

\* If fitted

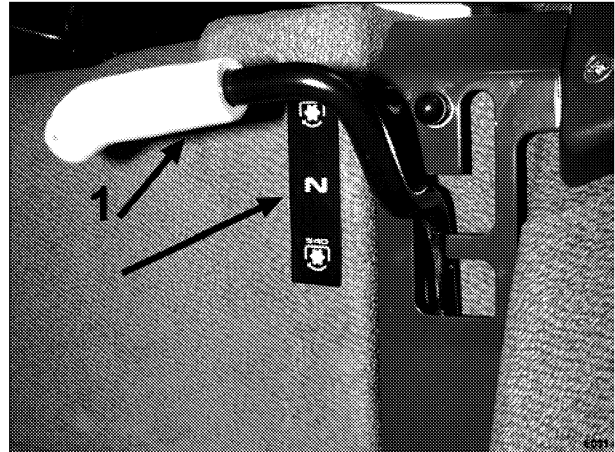

with proportional control \*

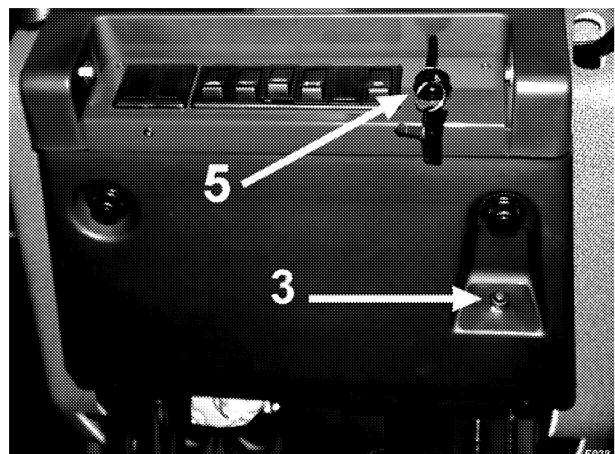
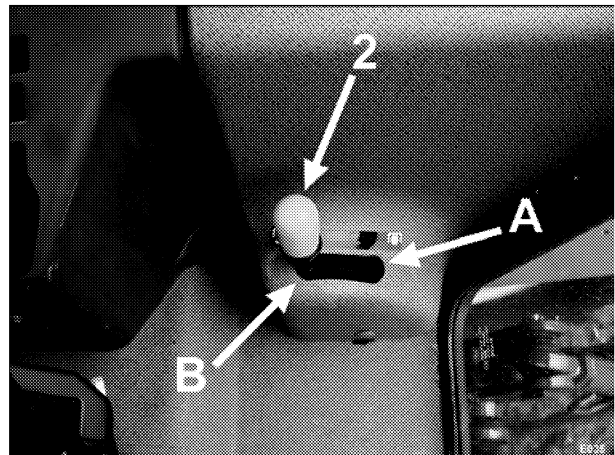

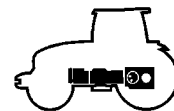

Every  
**750 h**  
or yearly

**ROUTINE MAINTENANCE**

Operations to be carried out  
every **750 h** or yearly



**SERVICE BRAKE \***

Drain - Refill - Bleed the brake circuit.

Brake fluid: **FRELUB HDS SAE  
J1703F DOT 3,4,5**

Quantity: **0.9 L**

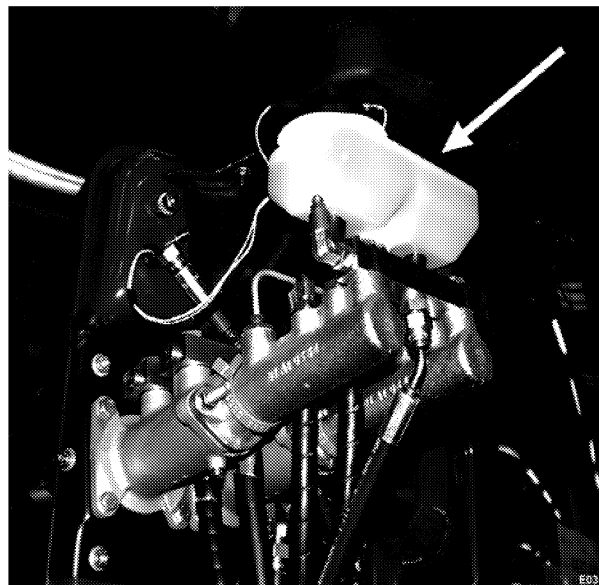

\* Operation to be referred to the RENAULT Agriculture network

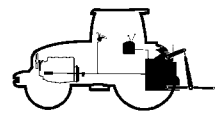

# G - HYDRAULICS - HITCH - COUPLING

## CONTENTS

<b>G.1 - CHARACTERISTICS*</b> .....	<b>G.117</b>
<b>G.2 - MECHANICAL TRACTO-CONTROL HITCH</b> .....	<b>G.121</b>
<b>G.3 - ELECTRONIC TRACTO-CONTROL HITCH TCE 4 *</b> .....	<b>G.124</b>
G.3.1 - CONTROL PANEL .....	G.124
G.3.2 - HITCHING CONDITIONS.....	G.124
G.3.3 - POSITION DISPLAY OPERATION .....	G.124
G.3.4 - STRESS CONTROL OPERATION .....	G.125
G.3.5 - TOP STOP ADJUSTMENT KNOB FUNCTION .....	G.126
G.3.6 - SENSITIVITY ADJUSTMENT KNOB FUNCTION (4) .....	G.126
G.3.7 - WORK POSITION OR TOP STOP PUSHBUTTON FUNCTION.....	G.127
G.3.8 - USE OF MAXIMUM SENSITIVITY .....	G.128
G.3.9 - EXTERNAL CONTROL BUTTON FUNCTIONS.....	G.128
G.3.10 - APPLICATION OF ELECTRONIC TRACTO-CONTROL HITCH TO THE VARIOUS IMPLEMENTS.....	G.128
<b>G.4 - AUXILIARY DISTRIBUTORS.....</b>	<b>G.131</b>
<b>G.5 - REAR COUPLING ADJUSTMENT INSTRUCTIONS.....</b>	<b>G.133</b>
G.5.1 - EFFECT OF COUPLING GEOMETRY ON HITCHING CAPACITY .....	G.133
G.5.2 - ADJUSTING THE HITCH CONNECTION RODS .....	G.134
G.5.3 - ADJUSTING THE UPPER ROD .....	G.135
<b>G.6 - AUTOMATIC COUPLING.....</b>	<b>G.136</b>
G.6.1 - AUTOMATIC HOOKS .....	G.136
G.6.2 - PICK-UP HOOK* .....	G.137
G.6.3 - CRAMER LADDER* .....	G.137
<b>G.7 - MAINTENANCE.....</b>	<b>G.138</b>
G.7.1 - GENERAL.....	G.138

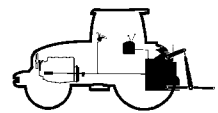

**Safety**

- After position 0, going past a friction point locks in up hitching position.

**IMPORTANT:** This position must be used when transporting mounted implements on roads.

When back in the field, use this knob, while at the same time verifying hitching, to put the implement on the ground.

This is in order to always control:

- The down speed (positioning without impacts if the ground is hard).
- Stop lowering (an unexpected person may be in the storage area).

**G.3.4 - STRESS CONTROL OPERATION**

This knob is used to precisely adjust the stress applied by the implement following detection.

**Use:**

Rotation to 0 implements less stress (implement up) and rotation to 9 implements more stress (implement top-soiling).

**Safety:**

- After 9, passing by a friction point **cancels the stress control**.
- This position is used during special work:

for example, very deep work or when work does not require stress control.

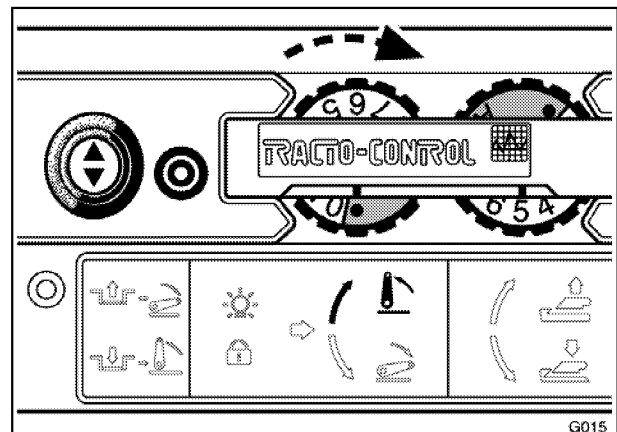

LOCKING

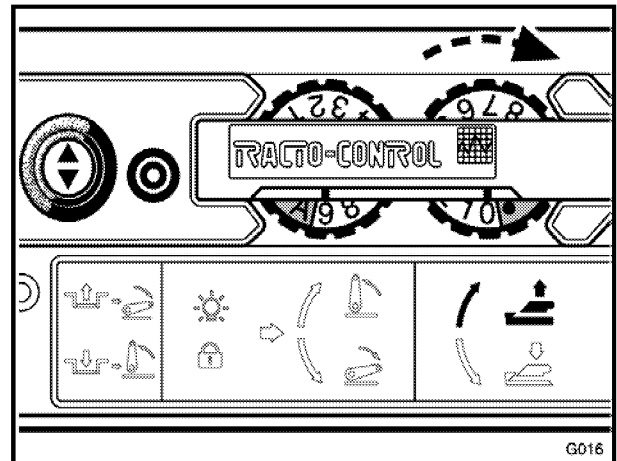

MINIMUM STRESS

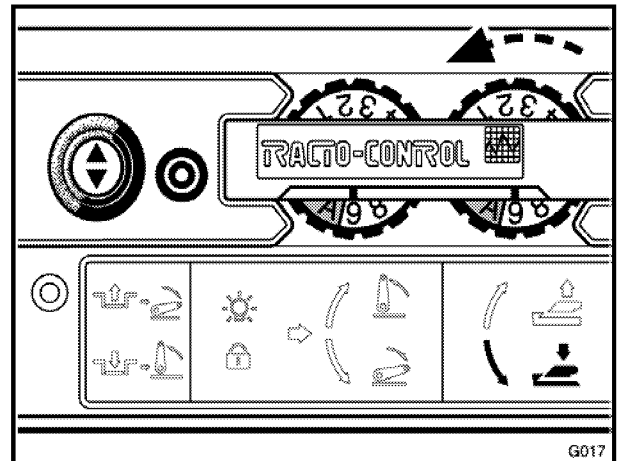

MAXIMUM STRESS

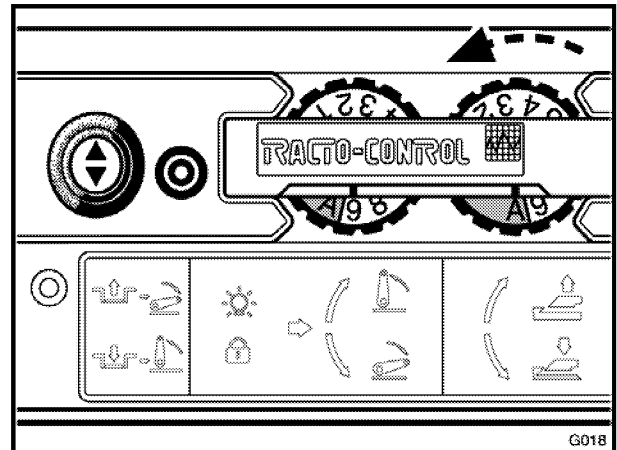

CANCEL

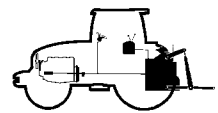

### G.5.3 - ADJUSTING THE UPPER ROD

- **Conditions for adjustment**

- Ball joint end fitting (A) in the coupling of the high point bar.
- Hold the other end with the automatic hook (C) in your hand.

- **Adjustment**

- Hitch the adjusting handle (B) and turn the central body to adjust the length of the rod.

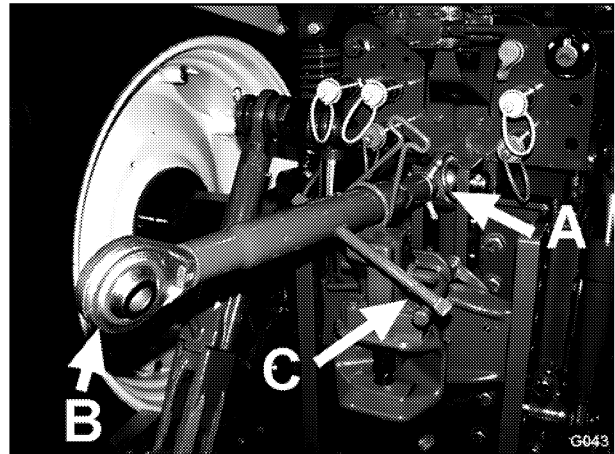

**IMPORTANT:** The following must be checked:

- That the lengths of uncovered thread (D) are the same (max difference 5 mm).
- That the difference between the centre lines (E) of the upper rod does not exceed 770 mm.

**Note:** When adjustment is finished, fold the adjusting handle (C) onto the central body and fit the rod to the implement arm.

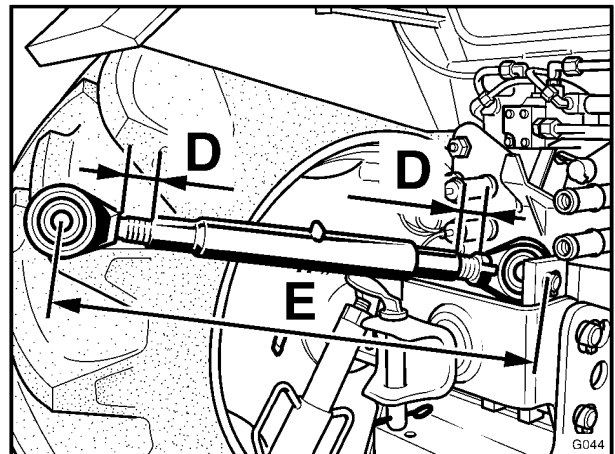

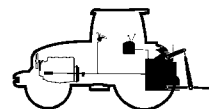

Every  
**1500 h**  
or  
yearly

**ROUTINE SERVICING**  
Operations to be carried out  
every **1500 h** or yearly



### **REPLACING THE STRAINER (INTAKE)**

- **Access:** The strainer (intake) (A) is on the right-hand side of the transmission. Loosen collars 1, 2, 3, 4 and 5 to remove the strainer and replace it.

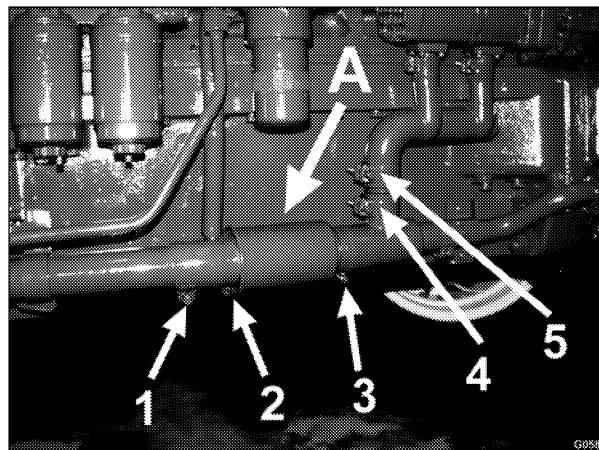

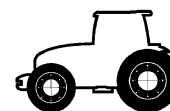

# J - WHEELS AND TYRES

## CONTENTS

J.1 - GENERAL .....	J.156
J.2 - TYRE PRESSURES .....	J.158
J.3 - WATER BALLAST .....	J.159
J.4 - FRONT TRACK: TEMIS 550.....	J.160
J.5 - REAR TRACK: TEMIS 550.....	J.161
J.6 - REAR TRACK: TEMIS 550.....	J.162
J.7 - SETTING THE TRACK .....	J.163
J.7.1 - FRONT DRIVE SHAFT .....	J.163
J.7.2 - STEERING LOCK STOPS.....	J.163
J.7.3 - REAR AXLE .....	J.164
J.8 - RECOMMENDED DISTANCE BETWEEN TYRE AND TRACKS FOR PLOUGHING .....	J.165
J.9 - DUAL WHEELS .....	J.166
J.10 - PRELIMINARY TESTING .....	J.166
J.11 - USING DEEP-WORKING IMPLEMENTS .....	J.166
J.12 - INSTRUCTIONS FOR FITTING NARROW TYRES.....	J.167
J.13 - TABLE OF SERVICE OPERATIONS .....	J.168
ROUTINE SERVICING .....	J.169
EVERY 100 H.....	J.169

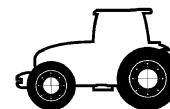

## J.8 - RECOMMENDED DISTANCE BETWEEN TYRE AND TRACKS FOR PLOUGHING (for a rear mounted ploughshare)

### DISTANCE BETWEEN TYRES

When ploughing, the distance between tyres of the tractor varies depending on the width of working per plough body and the number of bodies.

**Note 1:** A correct distance between tyres allows the plough cant to be adjusted properly. This adjustment must be such that the action of the soil against the implement cannot put any side loading onto the tractor. This would tend to make it deviate to the left or right and also absorb some of the tractive effort.

**Note 2:** The track required is equal to the distance between tyres plus the width of one tyre.

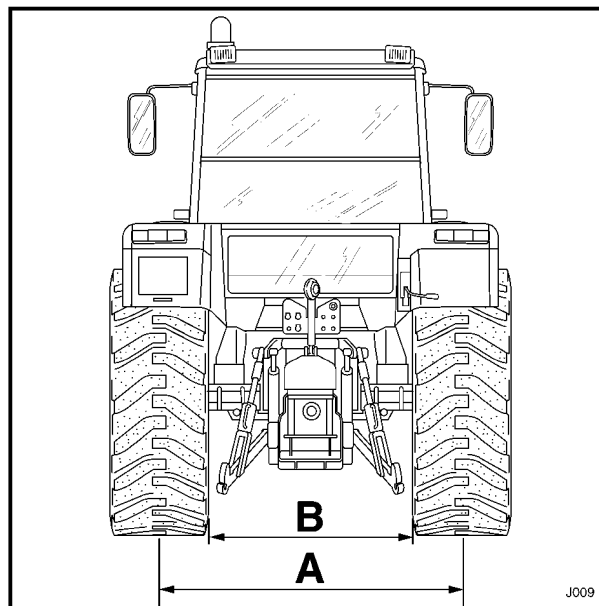

Work width per unit	Work gauge (in mm) with ploughs:								
	Two-furrow and three-furrow*			Four-furrow and five-furrow*			Four-furrow and five-furrow**		
	distance between tyres	Tyre width		distance between tyres	Tyres width		distance between tyres	Tyre width	
		16,9"	18,4"		16,9"	18,4"		16,9"	18,4"
12" (305 mm)	1180 mm	1600	1650	1330 mm	1800	1800	1470 mm	1900	2000
13" (330 mm)	1200 mm	1650	1700	1370 mm	1800	1900	1510 mm	2000	2000
14" (356 mm)	1230 mm	1700	1700	1400 mm	1850	1900	1550 mm	2000	2000
16" (406 mm)	1280 mm	1700	1800	1480 mm	1900	2000	1620 mm	2000	2000
18" (457 mm)	1330 mm	1800	1800	1560 mm	2000	2000	1700 mm	2000	2000

\* Standard II: 870 mm

\* Standard III: 1010 mm



### K.3 - CAPACITIES

- The diagram below shows the quantities of lubricant and fluid to be used for each component.
- Use **only** the recommended lubricants and fluids.
- **Never change the grade of oil or fluid** when topping up.
- Regular changing is essential.

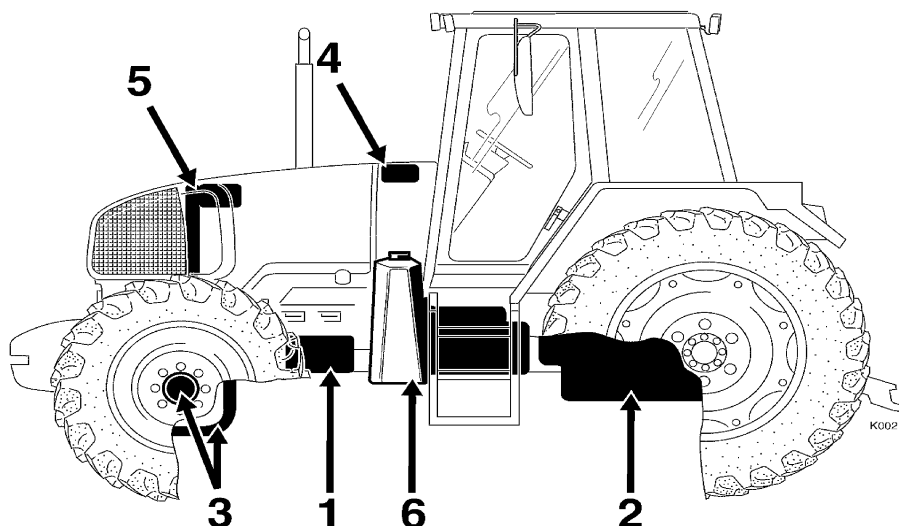

	TRACTOR COMPONENT	CAPACITY		RECOMMENDED LUBRICANT/FLUID
1	<b>ENGINE</b> - Sump: 4 cylinder engines.....	Min <b>10 L</b>	Max <b>12,5 L</b>	<b>ELF TRACTORENAULT SDMMultigrade</b> SAE 15W40 oil for turbocharged or normally-aspirated engines meeting the following specifications: ACEA E2.96 - API CG.4 - MIL.L.2104E - MIL.L.46152C
2	<b>TRANSMISSION / HITCH</b>	mechanical gearbox <b>60 L</b>		<b>G.A. 12</b>
		TRACTONIC gearbox <b>65 L</b>		
3	<b>FRONT AXLE:</b> - Differential casing..... - Final drive TEMIS 550.....	<b>6 L</b> <b>0,6 L/ Final drive</b>		<b>TRANSELF BLS 90</b> Extreme pressure oil for lubricating limited slip or self-locking differentials API GL5 and MIL.L.2105D.
4	<b>BRAKE CIRCUIT</b>	<b>0,9 L</b>		<b>FRELUB HDS SAE J 1703 F - DOT 3,4,5</b>
5	<b>COOLING CIRCUIT</b> - TEMIS 550 .....	<b>18 L</b>		<b>RENAULT Agriculture coolant</b> (Glaceol Type D 50/50 for protection to at least -40°C)
6	<b>FUEL TANK</b> - TEMIS 550 .....	<b>X Version</b> <b>160 L</b>		

\* Remove 2 liters for tractors without heating

CLICK HERE TO **DOWNLOAD** THE COMPLETE MANUAL

- Thank you very much for reading the preview of the manual.
- You can download the complete manual from: [www.heydownloads.com](http://www.heydownloads.com) by clicking the link below



- Please note: If there is no response to CLICKING the link, please download this PDF first and then click on it.

CLICK HERE TO **DOWNLOAD** THE COMPLETE MANUAL