

# F 380A.24

## use and maintenance

Edition ExtraCE 00 27.08.03

### INDEX

Chapter I	INTRODUCTION	page 2
II	SAFETY NORMS	page 3
III	INSTRUCTIONS FOR CRANE USE	page 5
IV	IDENTIFICATION OF THE CRANE MODEL	page 6
V	TECHNICAL DATA	page 7
VI	CRANE NOMENCLATURE	page 9
VII	SAFETY AND PROTECTION DEVICES	page 10
VIII	LIFTING MOMENT LIMITING DEVICE AND CONTROL PANELS	page 11
IX	CONTROLS TO STABILIZE THE VEHICLE	page 16
X	CONTROLS TO OPERATE THE CRANE	page 21
XI	USE OF IMPLEMENTS	page 25
XII	MAINTENANCE INSTRUCTIONS	page 27
XIII	POSSIBLE FAULTS	page 32
XIV	HYDRAULIC AND ELECTRIC SCHEMATICS	page 33
XV	OIL AND LUBRICANT CHARACTERISTICS	page 39
A	INSTRUCTION AND WARNING PLATES	page 40
B	CAPACITY PLATES	page 43

CLICK HERE TO **DOWNLOAD** THE COMPLETE MANUAL

- Thank you very much for reading the preview of the manual.
- You can download the complete manual from: [www.heydownloads.com](http://www.heydownloads.com) by clicking the link below



- Please note: If there is no response to CLICKING the link, please download this PDF first and then click on it.

CLICK HERE TO **DOWNLOAD** THE COMPLETE MANUAL

## Lifting moment limiting device and controls panels

The device called "lifting moment limiting device" preserves the crane structure from overloads, as it prevents any movement which increases the value of the moment up to the maximum established value.

The lifting moment limiting device concerns the following manoeuvres:

- Inner boom descent; the inner boom lift is controlled by the general main pressure valve of the distributor.
- Outer boom lift.
- Outer boom descent.
- Extension of extension boom sections.
- Winch rope lift (if fitted).
- If hydraulic extension is fitted: extension outer boom lift.
- Extension outer boom descent.
- Extension of the jib extension booms section.

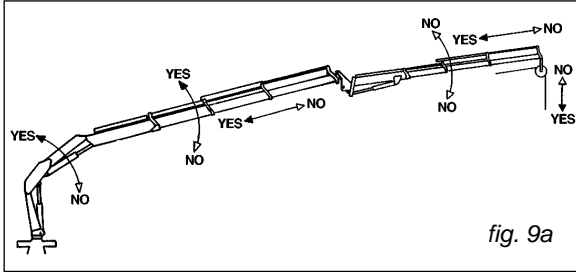

fig. 9a

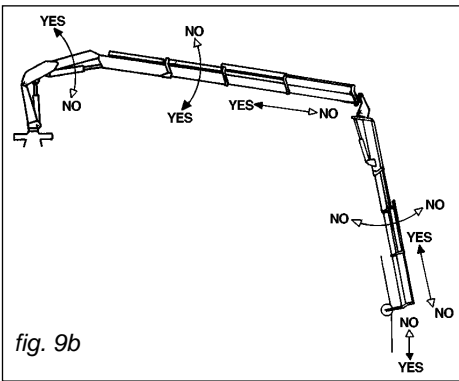

fig. 9b

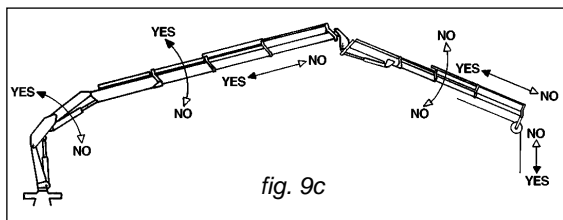

fig. 9c

The crane configurations (fig. 9a-b-c) (and the eventual hydraulic extension) indicate the manoeuvres which are allowed and not allowed by the device, in connection with the horizontal position of the crane and extension outer booms.

### Lifting moment limiting device "INTELLIGENT TYPE" (optional)

This device is fitted close to the distributor, whose specific functions it uses. It utilises an electrohydraulic technology, preventing any movement which causes an increase in the pressure induced by the load in the inner and outer rams of the crane (and in the outer ram for the hydraulic extension if fitted), up to the "critical values" which have been established in the structural test. These values, which are non-exceedable, determine the intervention levels and provide the data for setting the device.

The device is based on hydraulic controls which are activated when the intervention value is reached and block the movements of the relevant distributor levers in one or both directions. Please remember that the device will return the lever of the element being used to neutral position. The condition of intervention is operated by the position of the outer boom (or, if hydraulic extension is fitted, the position of the extension outer boom), on which the electronic signal position (mercury level switch) is read by a special electrovalve. This determines the controls of the locking or unlocking (resetting) of the controls concerned.

### Lifting moment limiting device for two working areas (optional)

In case of one sector of the working area with no sufficient stability of the vehicle (e.g. sector in front of vehicle cab) the limiting device, by means of a special function, allows, using the rotation arc limiter as well as an adjustable electro-hydraulic device, to operate with a reduction of the intervention level.

The reduction of the intervention level reduces the crane capacity values and this reduction value is defined in the vehicle stability calculation.

Consequently the working area is divided in one sector (e.g. body side) where the crane works according to the capacity plate values and another sector (e.g. cab side) where it works with reduced capacity values.

The device has consequently two intervention levels which are activated in relation to the sector of the crane working area always securing the vehicle stability.

### (!) ATTENTION (!)

If the rotation stops by going through the working zone where the crane can operate according to the capacity plate values to the one where it can operate according to the reduced values, it means that one of the following conditions is reached:

- manoeuvre of a load bigger than the one admitted in the reduced sector defined in the vehicle stability calculation
- manoeuvre without load with (at least) one of the inner, outer rams of the crane or the jib (if fitted) extended till the stroke end.

The only one allowed manoeuvre is the crane rotation in the reversed sense, and consequently, an action which respectively allows to reduce the moment or to re-enter the inner ram(s), the crane outer ram, the jib outer ram.

## Manoeuvres to unfold the crane into a working condition (fig. 29)

- Engage the power take off.
- Stabilize the vehicle as described on page 16.

### (!) IT IS FORBIDDEN TO OPERATE FROM THE DOUBLE CONTROL SIDE (!)

#### (!) Operate from ground control distributor side (!)

- Operate the lever **I** (re-entry) to ensure that the extension booms are re-entered.
- Before lifting the inner boom, be sure that the outer ram is closed (operate the lever **H** re-entry function).
- Lift the inner boom over the horizontal line, by operating lever **G** (fig. 30).
- Open the outer boom to the “horizontal” position by operating lever **H**.
- (Eventually) extend the booms of the crane by operating lever **I**.
- Position the hook on the vertical line above the load, operating lever **F** (rotation).

## Manoeuvres to fold the crane into the rest condition

### (!) IT IS FORBIDDEN TO OPERATE FROM THE DOUBLE CONTROL SIDE (!)

#### (!) Operate from ground control distributor side (!)

- Fold the extension booms to their stroke end.
- Lift the inner boom to its stroke end.
- Fold the outer boom to its stroke end.
- Operate the rotation control until the arrows placed on the base and on the column (dust cover) coincide.
- Fold the inner boom to its stroke end; the rest locating pin locates into its seat (fig. 30).
- Lift and re-enter the outriggers to within the overall vehicle width as described at page 16.

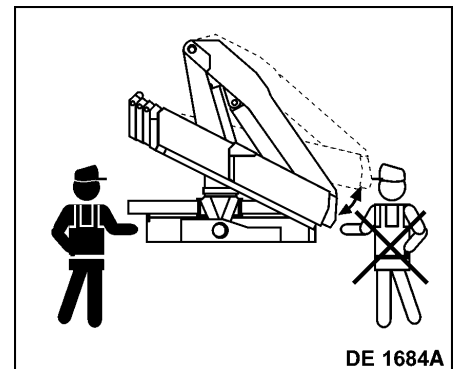

fig. 30

## POSSIBLE FAULTS

Many years experience of our product has allowed us to identify and classify the most common faults which occur. In most cases it requires accurate hydraulic and electric troubleshooting and simple rectification. In the following table we report the most frequent inconveniences and our suggested remedies.

**(!) Checking and adjustment of oil pressures of valve settings must be carried out by an authorized service agent, under penalty of warranty forfeiture.**

### Operations which can be carried out by the user.

<b>Faults</b>	<b>Cause</b>	<b>Remedies</b>
The crane does not rotate properly	<i>Vehicle non in level position</i>	Stabilize the vehicle
	<i>Lack of lubrication</i>	Grease the bushes of the column and the guide shoe
The extension booms do not completely extend or work jerkily	<i>Lack of lubrication of the guide shoes</i>	Grease the guide shoes
Crane controls are not active	<i>Lack of electric energy</i>	Check the fuse, the battery and electric circuit
	<i>Winch end stroke active</i>	See Chapter XI
	<i>The rotation limiting device is activated</i>	See Chapter VIII
Vibrations in crane operations	<i>Shortage of oil</i>	Check the level and top up if necessary
	<i>Obstructed filters</i>	Clean or replace the filter cartridge
Noteable decrease in movement speed	<i>Obstructed filters</i>	Clean or replace the filter cartridge

### Operations to be carried out by a service center.

<b>Faults</b>	<b>Cause</b>	<b>Remedies</b>
The crane does not lift the loads indicated on the capacity plate	<i>Non efficiency of the pump</i>	Replace the pump
	<i>Main pressure valve not properly adjusted, blocked or out of service</i>	Check the pressure, adjust the valve
	<i>Ram seals are not properly fitted</i>	Replace the seals
A boom of the crane does not hold up the load and visually lowers	<i>The safety check valve of the ram is open</i>	Replace the valve
	<i>Oil leaks inside the ram</i>	Defective seals, replace them
The crane does not rotate properly	<i>Valves controlling the rotation not adjusted</i>	Adjust the valves
	<i>Wear of the seals of the rotation cylinder</i>	Replace the seals
The extension booms do not completely extend or work jerkily	<i>Wear of guide shoes</i>	Check the guide shoes wear, replace if necessary
Vibrations in crane operations	<i>Non efficient pump</i>	Check the pump
Noteable decrease in movement speed	<i>Non efficient pump</i>	Check the pump

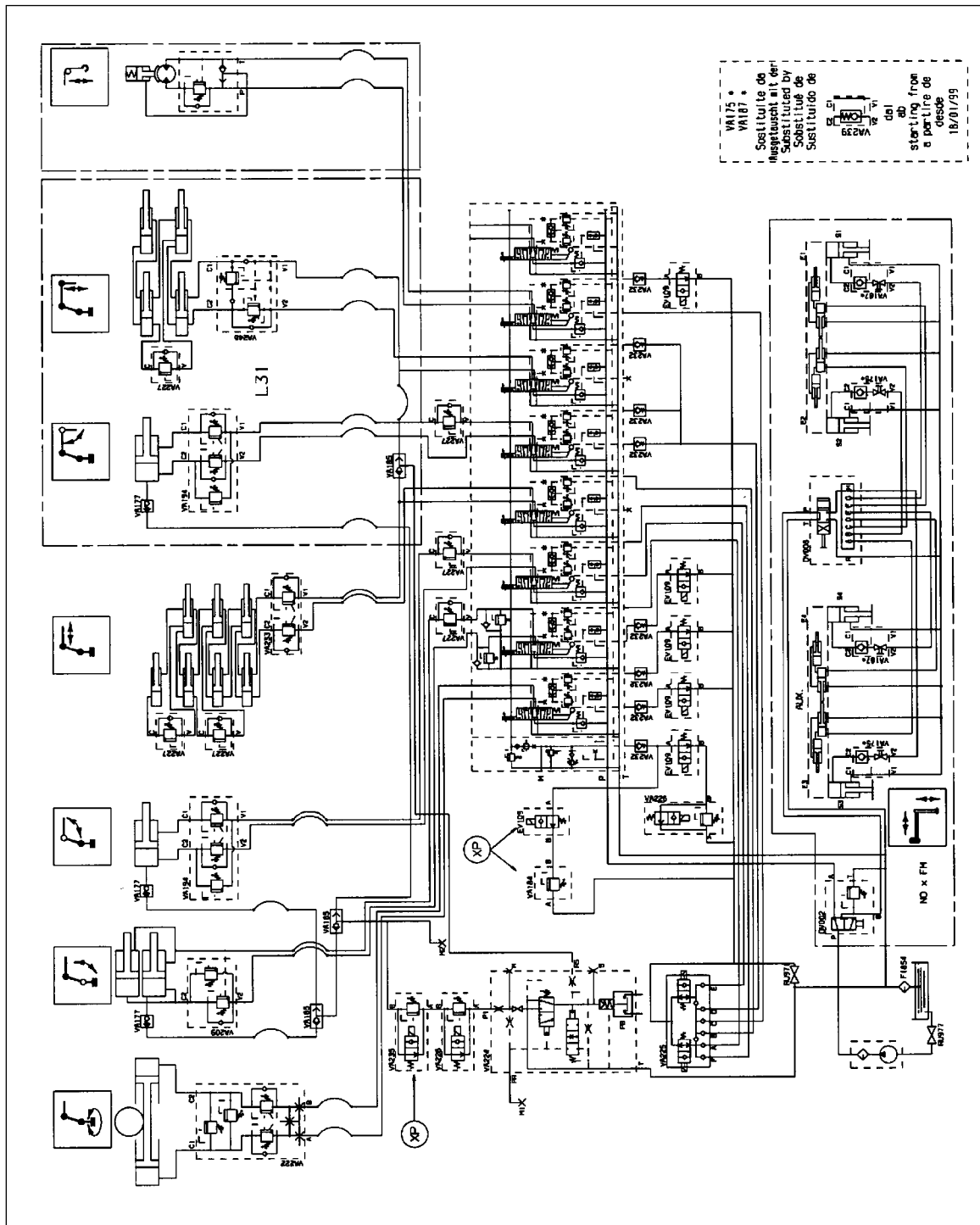

SYMBOL DESCRIPTION

DV005	DEVIATOR	VA194	DOUBLE EFFECT BLOCK VALVE
DV008	DEVIATOR	VA209	SIMPLE EFFECT BLOCK VALVE
EV109	ELECTROVALVE	VA224	LIFTING MOMENT LIMITING DEVICE VALVE
FI854	FILTER	VA225	LEVEL SENSOR VALVE
M1/M2	GAUGE QUICK CONNECTION	VA226	ELECTRIC MAIN WITH BY PASS VALVE
RU971	FAUCET	VA227	SEQUENCE VALVE
RU977	FAUCET	VA232	UNIDIRECTIONAL VALVE
VA239	SIMPLE EFFECT BLOCK VALVE	VA235	ELECTRIC MAIN WITH BY PASS VALVE
VA177	ANTIBURST VALVE FOR LIFTING RAMS	VA246	RIGENERATIV VALVE
VA184	SENSOR VALVE	VA247	OIL FLOW REGULATOR VALVE FOR ROTATION CYLINDER
VA185	SELECTOR VALVE		



CLICK HERE TO **DOWNLOAD** THE COMPLETE MANUAL

- Thank you very much for reading the preview of the manual.
- You can download the complete manual from: [www.heydownloads.com](http://www.heydownloads.com) by clicking the link below



- Please note: If there is no response to CLICKING the link, please download this PDF first and then click on it.

CLICK HERE TO **DOWNLOAD** THE COMPLETE MANUAL