

CLAAS KgaA mbH
Postfach 1163, 33426 Harsewinkel
Tel. +49 (0)5247 12-0
www.claas.com
00 11 329 120
TRACTOR
GB - 07.2006
Printed in France

Atles 926 • 936 • 946

Use and Maintenance

Use and Maintenance – Atles 926 • 936 • 946 – GB – 07.2006

CLICK HERE TO **DOWNLOAD** THE COMPLETE MANUAL

- Thank you very much for reading the preview of the manual.
- You can download the complete manual from: www.heydownloads.com by clicking the link below



- Please note: If there is no response to CLICKING the link, please download this PDF first and then click on it.

CLICK HERE TO **DOWNLOAD** THE COMPLETE MANUAL



CONDITION OF THE TRACTOR

Maintaining the tractor in the best possible condition, by carrying out all routine maintenance (oil changes, level checks, overhauls, adjustments and thorough cleaning) will allow it to be used in the safest and most profitable way.

Check the following items first:

- **High temperature components:** Check that airborne particles such as straw, grass, wood chips etc., do not accumulate in high temperature areas. Clear debris from around the engine and the exhaust system. For tools attached to the front or the side of the tractor, inspect and clean the areas around the attachments for the various supports.
- **Brakes:** Check that the brakes work properly. Check the operation of the hand brake and foot brake.
- **Steering:** Check the operation of the hydrostatic steering.
- **Transmission:** Check the transmission fluid level (especially if external services are used).
- **Hydraulic system:** Check the condition of the system (unions, pipes, hoses), particularly the hoses to the steering actuators.
- **Electrical system:** Check the condition of the electrical system (batteries, wiring, headlights, indicator lights, hazard lights, rotating beacons, windscreen wipers, etc.).
- **Lighting - indicators:** All lighting and indicating equipment must not only be in working order, but must be fully visible; clean them. Carry a spare set of bulbs. Replace any defective element.

Only fit genuine CLAAS parts. The CLAAS network is at your disposal for any parts or products required to keep your tractor in perfect working order.

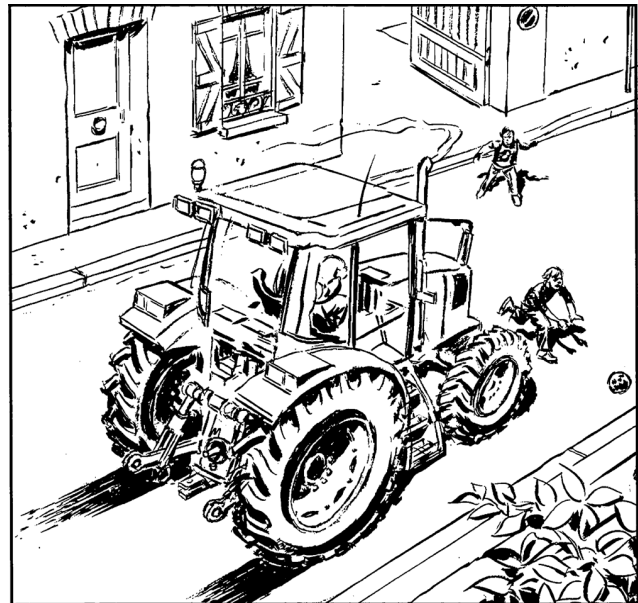

001hsn05





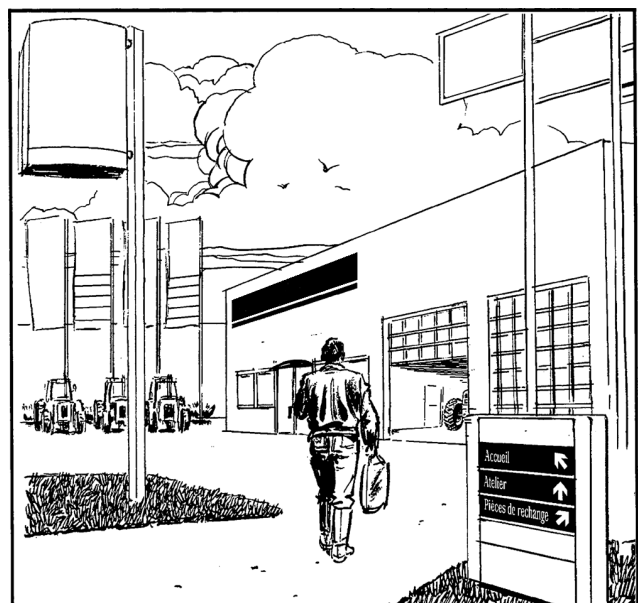



001hsn06

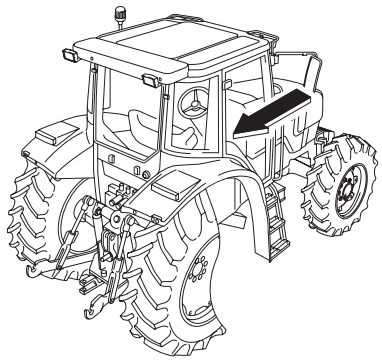

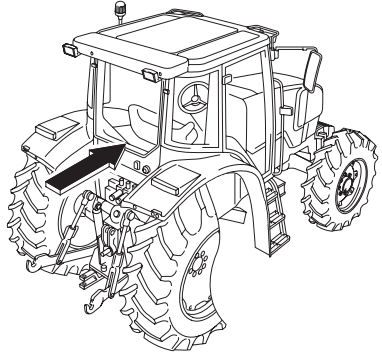
001hsn07

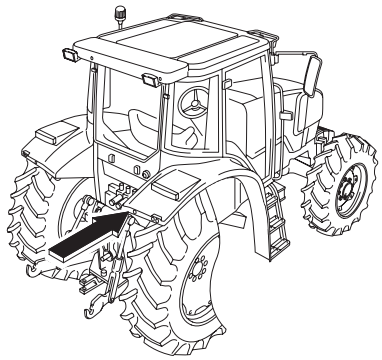

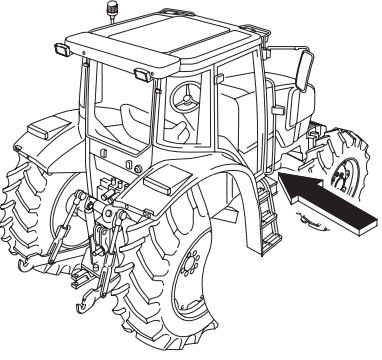
| Warnings | Pictogram | Location |
|--|--|--|
| <p>WARNING: The power take-off must not be used at 1 000 rpm unless the implement is designed to run at this speed (see the user's manual).</p> | <div style="border: 1px solid black; padding: 10px; text-align: center;"> <p>WARNING 1000 REV/MIN P.T.O. MUST NOT BE USED UNLESS IMPLEMENT IS DESIGNED TO BE AT THIS SPEED (SEE OPERATOR HANDBOOK)</p> </div> <p style="text-align: right; font-size: small;">781msn12</p> |  <p style="text-align: right; font-size: small;">781msn27</p> |
| <p>WARNING: To prevent accidents, disconnect hydraulic hoses (of the grab hook) from the tractor distributors immediately after locking on the implement.</p> | <div style="border: 1px solid black; padding: 10px;">  <p>WARNING TO PREVENT ACCIDENTS, DISCONNECT HYDRAULIC RELEASE HOSE PIPE (ON PICKUP HITCH) FROM TRACTOR'S HYDRAULIC SYSTEM, IMMEDIATELY AFTER LATCHING THE IMPLEMENT.</p> </div> <p style="text-align: right; font-size: small;">781msn13</p> |  <p style="text-align: right; font-size: small;">781msn28</p> |
| <p>WARNING: Keep clear of the working zone of the linkage and the power take-off when using external controls.</p> | <div style="border: 1px solid black; padding: 10px;">  <p>WARNING KEEP CLEAR OF LINKAGE WHEN OPERATING EXTERNAL CONTROL</p> </div> <p style="text-align: right; font-size: small;">781msn14</p> |  <p style="text-align: right; font-size: small;">781msn29</p> |
| <p>Do not place the starter terminals in contact with a tool that conducts electricity (danger of sparks).</p> | <div style="border: 1px solid black; padding: 10px;">  <p>▲ DANGER ▲ GEFAHR ▲ PERICOLO ▲ PELIGRO ▲ FARA</p> </div> <p style="text-align: right; font-size: small;">781msn17</p> |  <p style="text-align: right; font-size: small;">781msn31</p> |

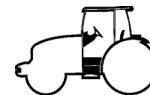

INSTRUMENTS

A - TACHOMETER

B - DIGITAL DISPLAY

- Real driving speed.
- Coolant temperature indicator.
- Fuel level indicator.

C - DIGITAL DISPLAY

- Engine speed (rpm).
- Rear power take-off speed (rpm).
- Front power take-off speed (rpm).
- Total hour meter.
- Trip hour meter.

D - TRANSMISSION DISPLAY

- 1 - Operation ratio: Front memorised.
- 2 - Neutral position indication.
- 3 - Front manoeuvre ratio.
- 4 - Manoeuvre ratio symbol.
- 5 - Transmission management in automatic mode.
- 6 - Indication of error code.
- 7 - Operation ratio: Rear memorised.
- 8 - Indication of forward direction.
- 9 - Engaging the park lock.
- 10 - Crawling range selected.
- 11 - Front axle engagement.
- 12 - Front and rear axle differential locking switch.

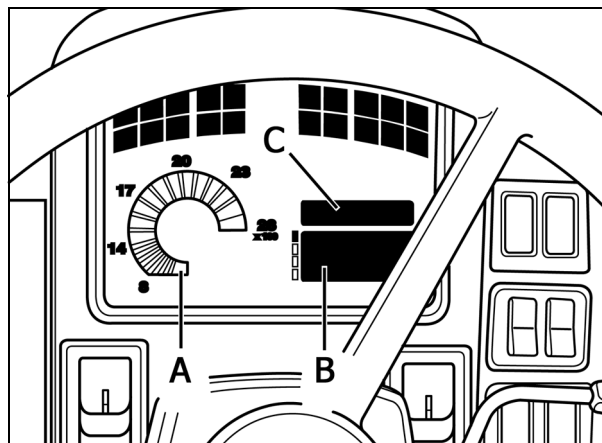

601hsn25

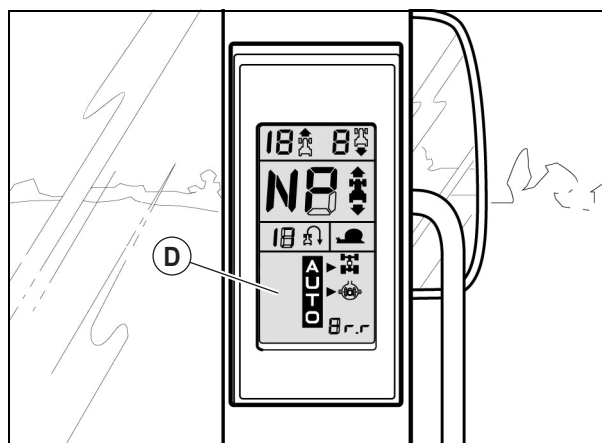

603hsn02

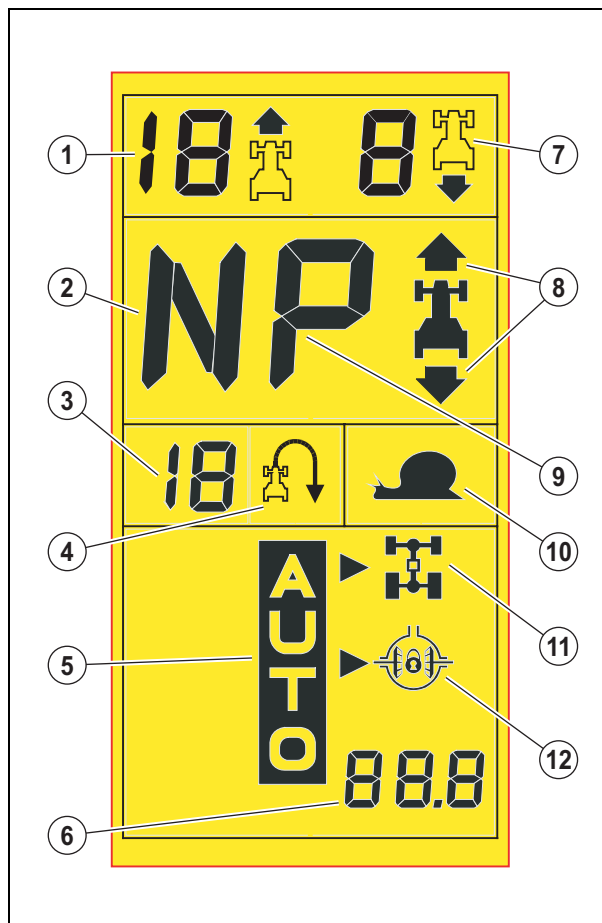

603hsn01



NATURAL VENTILATION

SIDE WINDOW

Opening left-hand side window, can be locked in the closed position and fixed open.

OPENING ROOF (D)

Can be released from inside the cab using handle. Held open by 2 struts.

The design of the opening roof means its direction of opening can be reversed. To do this, undo the ends of the 2 struts (2), remove the hinge pins (3) then turn the opening roof round. Refit parts (2) and (3).

To alter the aperture of the opening roof, set the trunnions (4) to the (A) or (B) positions to obtain the desired aperture.

REAR OPENING WINDOW

Can be released from inside the cab using handle (6).

The panel is held in the open position by 2 struts.

The panel has a rear-view mirror (5) to make visibility of the hitch attachment easier.

WINDSCREEN SUN BLIND

WINDSCREEN

Pull handle (8) to adjust the blind to the required height.

To roll the blind up, press lever (7).



841hsn15

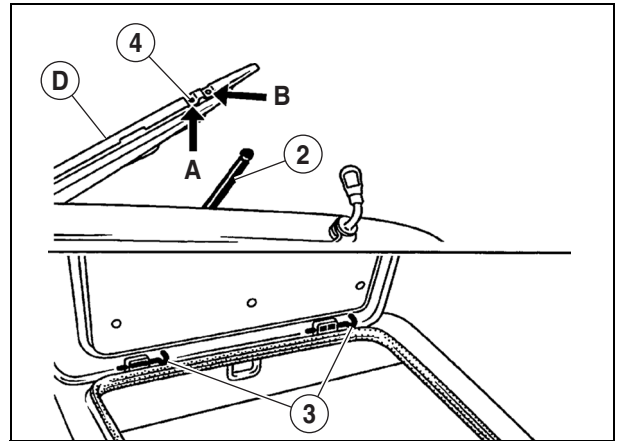

841hsn17



When driving on the public road the doors must be closed and latched.

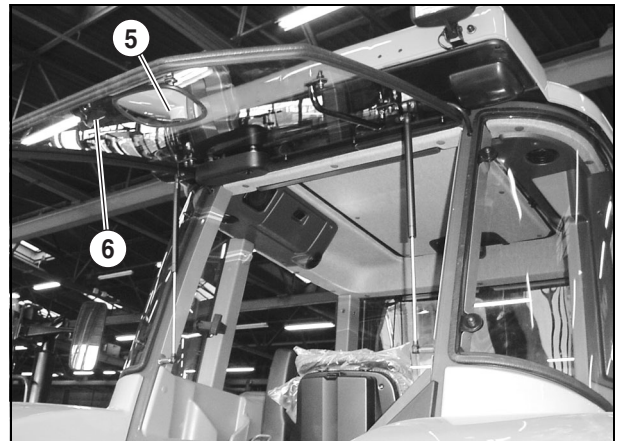

841hpn08

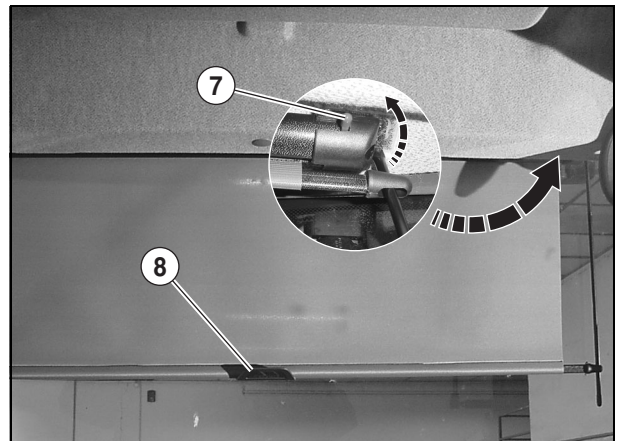

841msn06

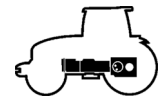

TABLES OF FORWARD SPEEDS

| Road speed in km/h and m.p.h. at 2200 engine rpm for Atlas 926 | | | | | | | | |
|--|----------------------------------|------|---------|------|--------------|-------|---------|-------|
| Gear under torque engaged | With the rear tyres 20.8 R 42 | | | | | | | |
| | Crawl range | | | | Normal range | | | |
| | Forward | | Reverse | | Forward | | Reverse | |
| | km/h | mph | km/h | mph | km/h | mph | km/h | mph |
| 1 | 0,60 | 0,37 | 0,60 | 0,37 | 2,40 | 1,50 | 2,40 | 1,50 |
| 2 | 0,80 | 0,50 | 1,00 | 0,62 | 3,10 | 1,92 | 4,00 | 2,48 |
| 3 | 1,00 | 0,62 | 1,10 | 0,68 | 4,00 | 2,49 | 4,60 | 2,49 |
| 4 | 1,10 | 0,68 | 1,70 | 1,05 | 4,60 | 2,86 | 6,70 | 4,16 |
| 5 | 1,30 | 0,80 | 1,90 | 1,18 | 5,20 | 3,23 | 7,60 | 4,72 |
| 6 | 1,50 | 0,93 | 2,40 | 1,50 | 5,90 | 3,66 | 9,80 | 6,09 |
| 7 | 1,70 | 1,05 | 3,20 | 1,99 | 6,70 | 4,16 | 12,60 | 7,83 |
| 8 | 1,90 | 1,18 | 4,60 | 2,85 | 7,60 | 4,72 | 18,50 | 11,50 |
| 9 | 2,10 | 1,30 | – | – | 8,60 | 5,34 | – | – |
| 10 | 2,40 | 1,50 | – | – | 9,80 | 6,09 | – | – |
| 11 | 2,80 | 1,74 | – | – | 11,10 | 6,89 | – | – |
| 12 | 3,20 | 1,99 | – | – | 12,60 | 7,83 | – | – |
| 13 | 3,60 | 2,23 | – | – | 14,30 | 8,88 | – | – |
| 14 | 4,10 | 2,54 | – | – | 16,30 | 10,13 | – | – |
| 15 | 4,60 | 2,85 | – | – | 18,50 | 11,50 | – | – |
| 16 | 6,00 | 3,72 | – | – | 23,80 | 14,80 | – | – |
| 17 | 7,80 | 4,84 | – | – | 30,80 | 19,20 | – | – |
| 18 | 9,90 | 6,15 | – | – | 39,70 | 24,67 | – | – |

Note: These values are given as an indication only. They are dependent on 3 parameters:

- Tyre inflation pressure ;
- Tyre wear ;
- Wheelspin coefficient.

Only a measurement in the field under working conditions can give an accurate value. The speeds are expressed in km/h, to convert them into mph proceed as follows:

- 1 km/h = 0,621 mph .
- 1 mph = 1,609 km/h.

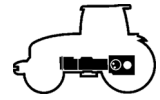

DIFFERENTIAL LOCK

- Do not wait for one wheel to spin before locking the differential.
- Do not lock the differential when the wheel is spinning at high speed.
- When the tractor is started the differential is always unlocked, whatever the state memorised when the engine stopped.

Note: The front axle differential lock is engaged simultaneously with the rear differential lock. Lights (K) and (J) are on. When the differential lock is disengaged, the front axle remains engaged.

TEMPORARY ENGAGEMENT (1)

Engagement of the rear and front differential lock is obtained by pressing button (E). Lights (F), (K) and (J) come on and the front axle is engaged.

To disengage the differential of the front and rear axle, press switch (E) again. Light (K) goes out (the front axle remains engaged and light (J) remains on). An action on the brake pedals definitively disengages the differential lock.

PERMANENT ENGAGEMENT (2)

Hold down button (E) for more than 2 seconds when tractor speed is less than 14 km/h. Warning light (K) flashes. Only an action on the 2 brake pedals can definitively disengage the front and rear differential locks.



602hsn33

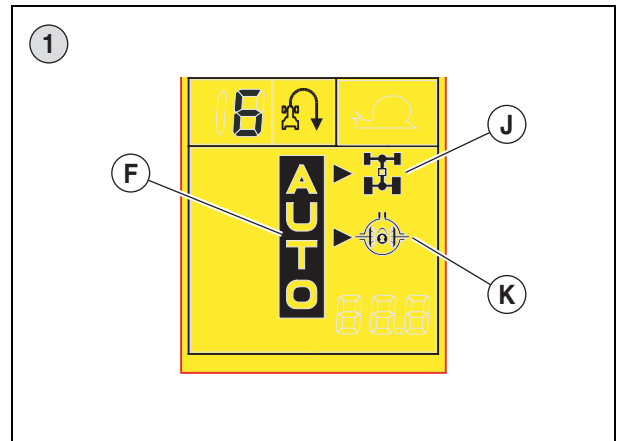

602hsn23

ELECTRONIC MANAGEMENT OF THE DIFFERENTIAL LOCK

TEMPORARY DISENGAGEMENT

The differential lock is disengaged:

- When the linkage arms leave the working position.
- Depending on the speed and the turn angle of the front axle.

1st case: From 0 to 10 km/h.

Differential locking is engaged up to a turn angle of 15°. At a greater angle, it is temporarily disengaged to enable end of field operations.

2nd case: From 10 to 14 km/h.

Differential locking is engaged up to a turn angle of 5°. At a greater angle, it is temporarily disengaged. When the linkage returns to the working position the differential lock is automatically reengaged.

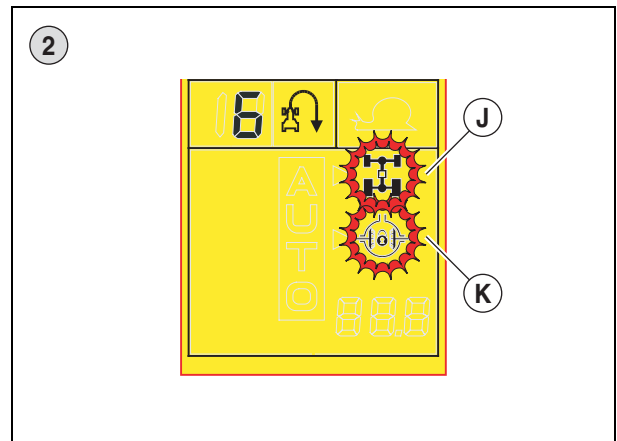

602hsn29

CLICK HERE TO **DOWNLOAD** THE COMPLETE MANUAL

- Thank you very much for reading the preview of the manual.
- You can download the complete manual from: www.heydownloads.com by clicking the link below



- Please note: If there is no response to CLICKING the link, please download this PDF first and then click on it.

CLICK HERE TO **DOWNLOAD** THE COMPLETE MANUAL



DIFFERENTIAL LOCKING

The central electronic unit (UCE) engages the front axle as soon as the differential lock begins to function (front axle/rear axle) by pressing button (C). Lights (B) and (D) come on.

Note: The central electronic unit (UCE) does not disengage the front axle when the differential lock is deactivated (warning light (B) remains on).

For more details about the management of the front and rear differential lock according to the speed and steering angle, refer to chapter E.

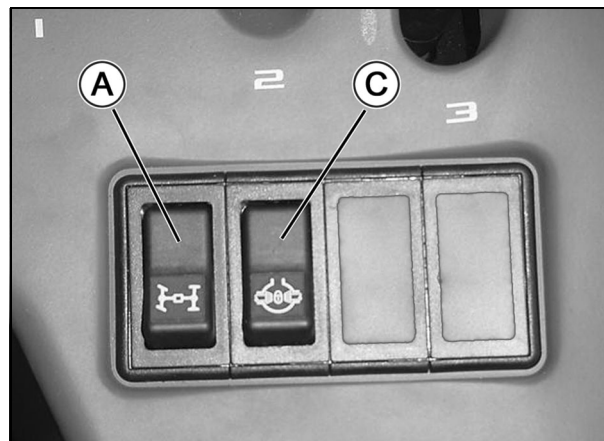

602hsn32

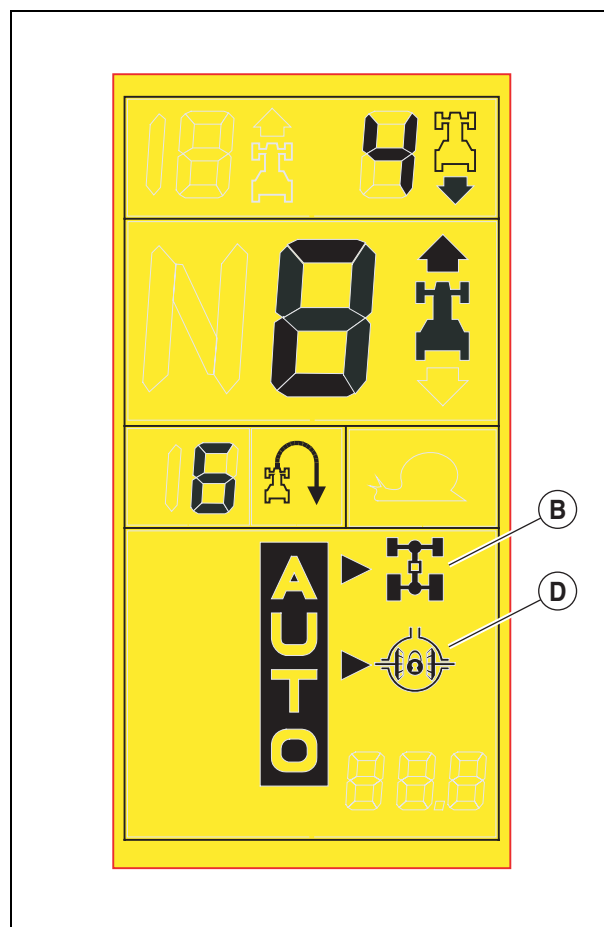

602hsn07

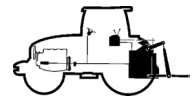

AUXILIARY SPOOL VALVES

Matching power take-offs with indications:

Indication 1 for power-take-offs (1).

Indication 2 for power-take-offs (2).

Indication 3 for power-take-offs (3).

Indication 4 for power-take-offs (4).

Indication 5 for power take-offs (5), (A) and (B).

To facilitate installation of hoses on power takeoffs, the takeoffs are fitted with valves (H).

DUAL EFFECT SPOOL VALVE 1 AND 2

Connection: On the power take-offs (1) and (2).

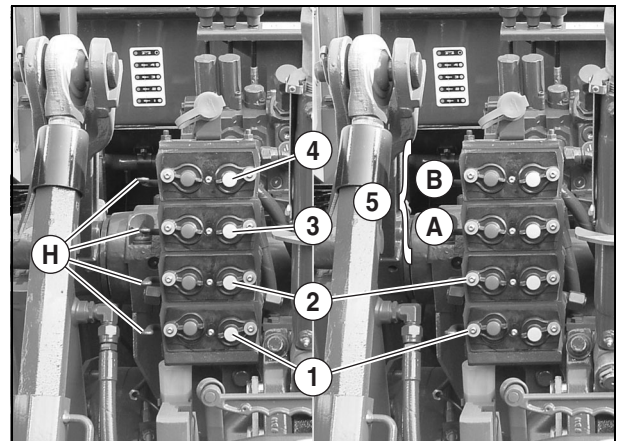

393hsn06

| Lever positions (1)* | | Power take-offs |
|----------------------|--------------|-------------------|
| Position (A) | Power supply | Pressure (red) |
| Position (B) | Neutral | |
| Position (C) | Power supply | Pressure (yellow) |
| Position (D) | Floating | |

*Identical functioning for lever (2)

- Feed is progressive between positions (A), (B) and (C) of the lever.
- The lever is maintained in positions (A) and (C) by a hydraulic locking.

Note: Unlocking by pressure: You do not have to keep holding the spool valve control to fully extend or withdraw a ram. This remains in up or down position, once the ram is fully extended, the increased pressure in the circuit returns the spool valve to neutral.

In the floating position (D), the pressure take-offs communicate with the tank, which allows the hitched implement to follow the undulations of the land. This position is fitted with a lock.

Note: The sleeves (M) immobilise control levers in position (A), (B) or (C).

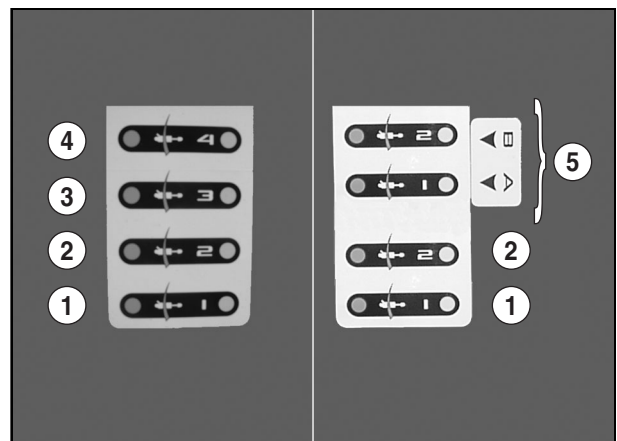

391hpn02

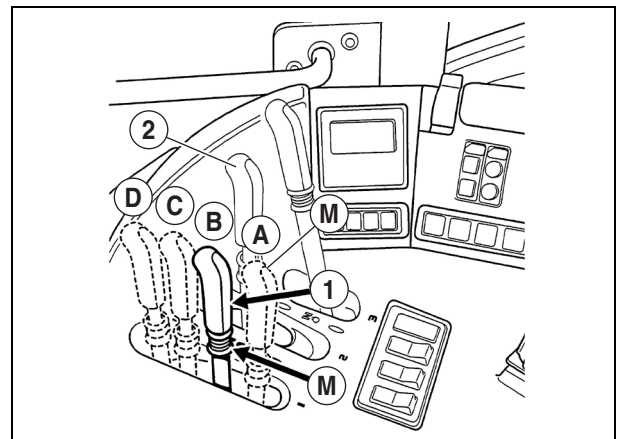

391hsn01



On road, or when the control levers are not used, lock these levers in the neutral position using the sleeves (M).

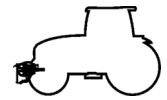

CHARACTERISTICS

FRONT LINKAGE

- 2 double-acting cylinders, controlled by the double-acting auxiliary distributor located in the cab.
- Blocking the circuit by the external valve.

CAPACITY 3 500 KG

- Automatic hooks, standard 3 (3/2 swivel).
- Fixed or floating (work) arm position.
- Foldable arms (Road or working position).

CAPACITY 6 600 KG

- Automatic hooks, standard 3 (3/2 swivel).
- Foldable arms (Road or working position).
- Top thrust rod and nitrogen ball.

DAMPER

On the 3 500 and 6 600 kg versions, a nitrogen ball damper (1) is adapted on the "upwards" lift supply circuit. This damper protects the tractor beam when travelling with heavy loads on the road.

SPECIAL WEIGHING-DOWN WEIGHT

The weighing-down weights are available depending on the tractor equipment. (see chapter K)

FRONT POWER TAKE-OFF

- Drive by direct connection to crankshaft.
- Electro-hydraulic clutch.
- Single-speed gear reducer.
- Power take-off rpm at engine rated rpm:
1000 rpm for 2200 engine rpm.
- 1" 3/8 inch output shaft, 6 splines.
- Continuous admissible power: 103 kW (140 hp).
- Direction of rotation: Clockwise or counterclockwise.
- Electric control with switch on right panel.
- Operating indicator and power takeoff rotation speed display on instrument panel.



411hsn00

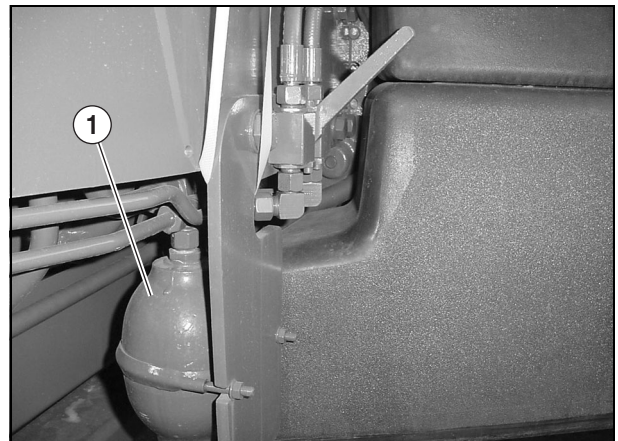

411hsn08



414hpn00

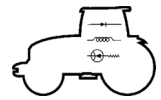

TOTAL WORKED SURFACE FUNCTION

From the previous configuration, pressing key (C) for more than 2 seconds gives access to the total worked surface.

The display unit indicates the total worked surface since the last reset.

The cycle reset is accessible with key (A) which simultaneously resets the partial and total surface worked counter.

Counting may be stopped and manually continued at all times using key (B).

● Lit: Counter stopped.

● BLINKING: Counter on.

Counting is related to the position of the lifting arm (function valid for lifting TCE 15 and 25).

Display : In hectares and tenths of a hectare.

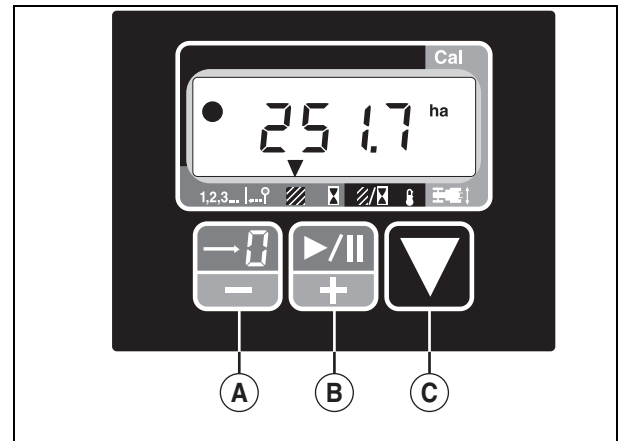

581hsn09

PARTIAL WORKED TIME FUNCTION

With key (C), put index ▼ in front of symbol  .

The display shows the working time since the last reset.

Resetting is accessible at all times using key (A) and does not reset the total worked time counter.

Counting may be stopped and manually continued at all times using key (B).

⌚ Lit: Counter stopped.

⌚ BLINKING: Counter on.

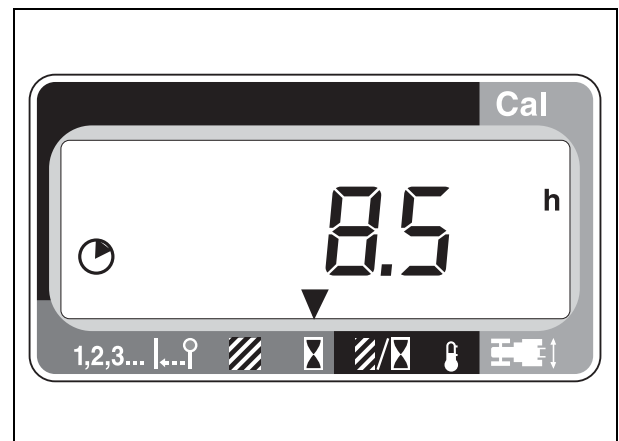

581hsn10

TOTAL WORKED TIME FUNCTION

From the previous configuration, pressing key (C) for more than 2 seconds gives access to the total worked time.

The screen gives the total time worked since the last zero reset.

The cycle reset is accessible with key (A) which simultaneously resets the partial and total worked time counter.

Counting may be stopped and manually continued at all times using key (B).

● Lit: Counter stopped.

● BLINKING: Counter on.

This frequently happens when working heavy land: It stops when the lifting arm moves up and starts again when the arm moves down.

- From 0 to 99,9 h, in hours and tenths of hours

- From 100 to 999 h, in hours

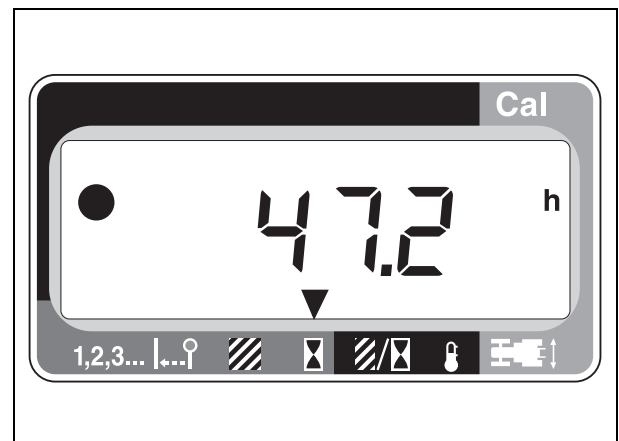

581hsn11



TABLES OF REAR TRACKS

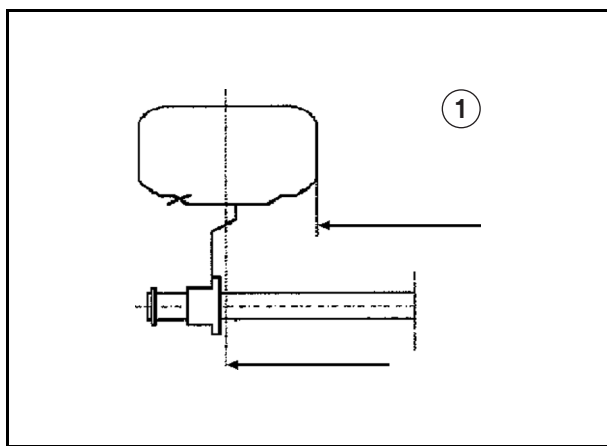

511hsn09

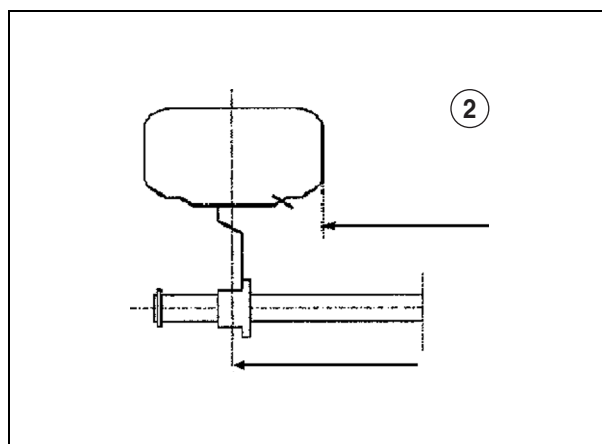

511hsn08

| | | | | | | | | |
|---|--------------|---------------|-------------------|-----------------|----------------|-------------------|-----------------|----------------|
| Type of rear axle: GPA 35 and 36 Smooth | | | | | | | | |
| Atlas 926 - 936 - 946 | | | | | | | | |
| Rims with fixed wheel disc | | | | | | | | |
| Rear tracks (in mm) | | | | | | | | |
| | | | Position 1 | | | Position 2 | | |
| | Tyres | Type | Minimum | Delivery | Maximum | Minimum | Delivery | Maximum |
| ✘ | 20.8 R 42 | DDW 18 L - 42 | 1744 | 1900 | 2261 | 1854 | 1900 | 2356 |
| | 620/70 R 42 | DDW 18 L - 42 | 1833 | 1900 | 2181 | – | 1900 | 2291 |
| | 650/65 R 42 | DDW 18 L - 42 | 1833 | 1900 | 2181 | – | 1900 | 2291 |
| | 650/75 R 38 | DWW 23 A - 38 | 1899 | 1900 | 2191 | – | 1900 | 2281 |
| | 650/85 R 38 | DWW 23 A - 38 | 1869 | 1900 | 2191 | – | 1900 | 2281 |
| | 710/70 R 38 | DWW 23 A - 38 | 1899 | 1900 | 2191 | – | 1900 | 2281 |

✘: Only Atlas 926.

Delivery track in bold.

| Tyre combinations | | | | |
|----------------------|---|-----------|-----------|-----------|
| Forwards | Reverse | Atlas 926 | Atlas 936 | Atlas 946 |
| 420/85 R 30 | 20.8 R 42 | X | | |
| 480/70 R 30 | 620/70 R 42 or 710/70 R 38 | X | | |
| 540/65 R 30 | 650/65 R 42 | X | | |
| 540/65 R 30 | 620/70 R 42, 650/65 R 42 or 710/70 R 38 | | X | X |
| 600/65 R 28 | 710/70 R 38 | | X | X |
| 600/65 R 28 (TOPKer) | 650/75 R 38 (TOPKer) | | X | X |
| 600/65 R 28 (TOPKer) | 650/75 R 38 | X | | |
| 600/70 R 28 (TOPKer) | 650/85 R 38 | X | | |
| 600/70 R 28 (TOPKer) | 650/85 R 38 (TOPKer) | | X | X |



GENERAL

ADVICE

Only regular meticulous maintenance can guarantee the correct operation of your tractor. Follow all the instructions given in this manual.

CLAAS declines all responsibility if maintenance instructions are not followed.

GENERAL CLEANING

Generally clean and inspect, in detail, the tractor whenever necessary. This will enable incipient problems to be detected and inconvenient incidents avoided.

Important: Never spray cold water onto the injector pump with the engine running: The hydraulic head may seize up.

HIGH-PRESSURE CLEANING SYSTEMS

High-pressure cleaning systems are highly effective but, when using them, always take care not to damage the lip seals that protect the tractor's mechanical components. Also avoid directly spraying electrical harness connectors.

ROUTINE MAINTENANCE

The user may perform certain maintenance tasks that do not require specific technical skills, in particular periodic maintenance operations, provided that the frequency and instructions in this manual are respected.

TOUCHING UP PAINTWORK

If bare metal can be seen, the paintwork should be touched up to avoid corrosion. Your CLAAS agent can supply aerosol cans to match the colour of your tractor.

WELDING

All forms of electric welding (spot or arc) can damage your tractor's electrical and electronic equipment. You are therefore strongly advised not to carry out any welding on the tractor (or even on a tool coupled to the tractor).

Important: If electric welding is required on the tractor, call your approved CLAAS agent.

FAILURES OR MALFUNCTIONS

- If the tractor suffers a failure.
- or a malfunction.
- or makes an abnormal noise.

call your CLAAS agent. He alone has the skills needed to correctly repair your tractor. You should also contact him if

simple adjustments you carry out yourself do not give the desired results.

DECREASE IN FLUID LEVEL

If the level of a fluid (oil, coolant etc.) decreases, top up as described in the section "Maintenance Operation". If the gauge remains in the red zone, or if the level drops again, contact your CLAAS approved repairer.

QUANTITY AND TYPE OF OIL

For maintenance operations requiring an oil change (see chapter "K").

GREASE QUALITY

For maintenance operations requiring greasing (see chapter "K").



Operation n° 22

FRONT WEIGHT ATTACHMENT BOLTS: CHECK

Check the tightness of bolt (R): Front weight attachments.

Operation n° 23

CAB "RECYCLED" AIR FILTER: CHECK - REPLACE

- Give a quarter turn to the butterfly screws (5).
- Lower the grille (6).
- Remove and replace the element (B).

Note: Filter (B) is correctly assembled when its foam seal is turned towards the rear of the tractor.

Operation n° 24

FRONT POWER TAKE-OFF BOX OIL: REPLACE

- Position the tractor on a flat horizontal surface.
- Place a suitable recipient under drain plug (S).
- Unscrew the plug (S).
- Once all the oil has drained out, replace the plug.
- Remove the retaining ring and the cover located behind the casing (U) in order to clean the compressed air filter.
- Top up via the filler cap (L) as shown in operation n° 17.

Note: It is advisable to change the filter when it can no longer be cleaned properly.

Operation n° 25

BATTERY TERMINALS: CLEANING - LUBRICATION

Clean and grease battery terminals (T).



Handle the battery with great care because it contains sulphuric acid that must not come into contact with the eyes or skin. If there is any such contact, rinse with copious amounts of water. Keep sparks, incandescence and flames well away from the battery elements: Risk of explosion.

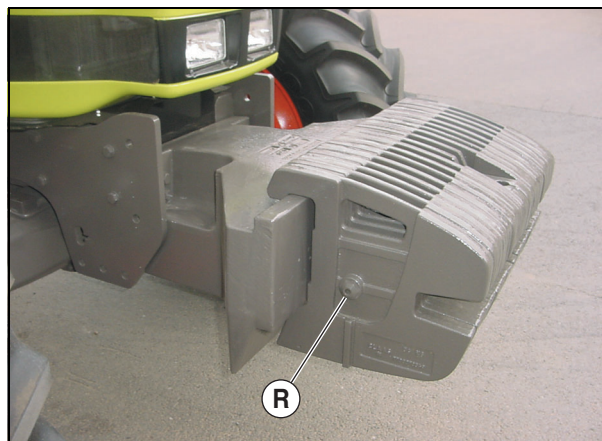

621hsn00

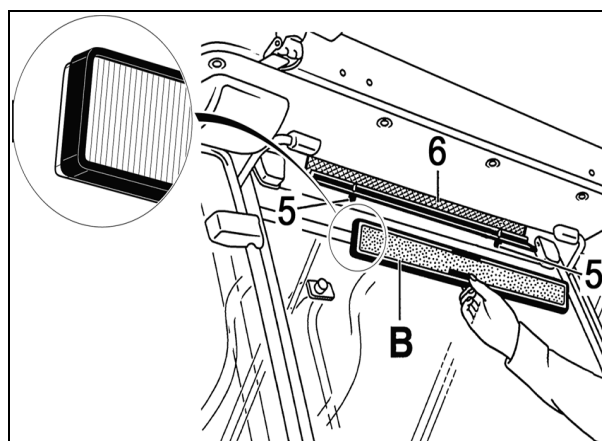

621hsn02



421msn01

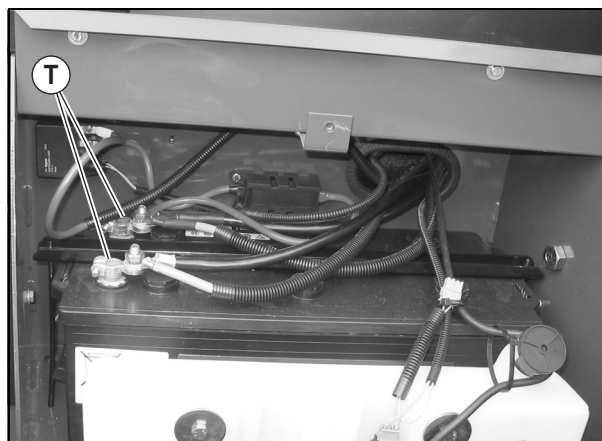

901hsn03



Operation n° 41

BRAKE SYSTEM FLUID: REPLACE

Replacing brake fluid and tank cap.

This operation is to be carried out by your approved CLAAS agent.

Operation n° 42

MAIN CAB AIR FILTER: REPLACE

- Undo nut (1).
- Remove air manifold (2), spring (3), plate (4) and air filter (5).
- Insert a new air filter and reassemble parts (4), (3), (2) and (1).
- To ensure correct assembly of plate (4), place the centre marker to be found under this plate on the air filter side.

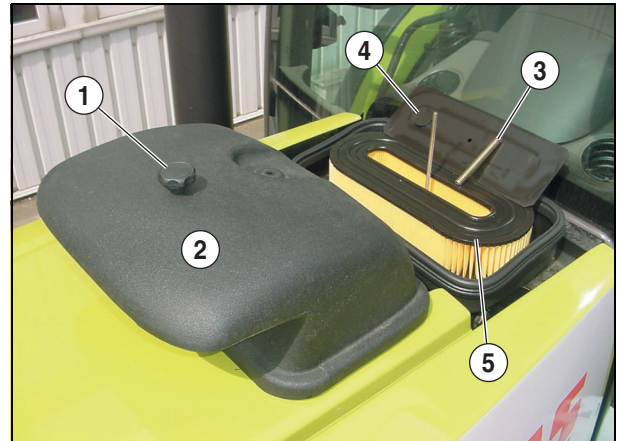

362hsn00

Operation n° 43

HYDRAULIC SYSTEM ACCUMULATOR: CHECK

Check accumulator pressure.

This operation is to be carried out by your approved CLAAS agent.

Operation n° 44

ROCKERS: ADJUSTMENT

Adjusting the valve rockers.

This operation is to be carried out by your approved CLAAS agent.

Operation n° 45

INJECTORS: CHECK

Checking the injectors.

This operation is to be carried out by your approved CLAAS agent.

CLICK HERE TO **DOWNLOAD** THE COMPLETE MANUAL

- Thank you very much for reading the preview of the manual.
- You can download the complete manual from: www.heydownloads.com by clicking the link below



- Please note: If there is no response to CLICKING the link, please download this PDF first and then click on it.

CLICK HERE TO **DOWNLOAD** THE COMPLETE MANUAL