

IMPORTANT

WARNING/CAUTION/NOTE

Please read this manual and follow its instructions carefully. To emphasize special information, the words **WARNING**, **CAUTION** and **NOTE** have special meanings. Pay special attention to the messages highlighted by these signal words.

WARNING:

Indicates a potential hazard that could result in death or injury.

CAUTION:

Indicates a potential hazard that could result in vehicle damage.

NOTE:

Indicates special information to make maintenance easier or instructions clearer.

WARNING:

This service manual is intended for authorized Suzuki dealers and qualified service mechanics only. Inexperienced mechanics or mechanics without the proper tools and equipment may not be able to properly perform the services described in this manual.

Improper repair may result in injury to the mechanic and may render the vehicle unsafe for the driver and passengers.

WARNING:

For vehicles equipped with a Supplemental Restraint Air Bag System:

- Service on and around the air bag system components or wiring must be performed only by an authorized SUZUKI dealer. Refer to “Air Bag System Components and Wiring Location View” under “General Description” in air bag system section in order to confirm whether you are performing service on or near the air bag system components or wiring. Please observe all WARNINGS and “Service Precautions” under “On-Vehicle Service” in air bag system section before performing service on or around the air bag system components or wiring. Failure to follow WARNINGS could result in unintentional activation of the system or could render the system inoperative. Either of these two conditions may result in severe injury.
- If the air bag system and another vehicle system both need repair, Suzuki recommends that the air bag system be repaired first, to help avoid unintended air bag system activation.
- Do not modify the steering wheel, instrument panel or any other air bag system component (on or around air bag system components or wiring). Modifications can adversely affect air bag system performance and lead to injury.
- If the vehicle will be exposed to temperatures over 93°C (200°F) (for example, during a paint baking process), remove the air bag system components (air bag (inflator) modules, SDM and/or seat belt with pretensioner) beforehand to avoid component damage or unintended activation.

CLICK HERE TO **DOWNLOAD** THE COMPLETE MANUAL

- Thank you very much for reading the preview of the manual.
- You can download the complete manual from: www.heydownloads.com by clicking the link below



- Please note: If there is no response to CLICKING the link, please download this PDF first and then click on it.

CLICK HERE TO **DOWNLOAD** THE COMPLETE MANUAL

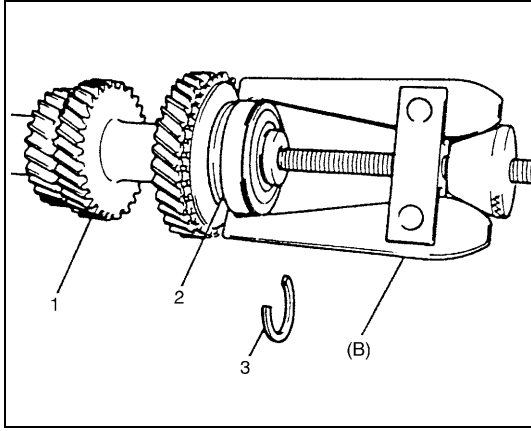

17) Remove circlip (3) of counter shaft (1) front bearing (2) and pull out bearing (2) by using puller.

Special tool
(B) : 09913-60910

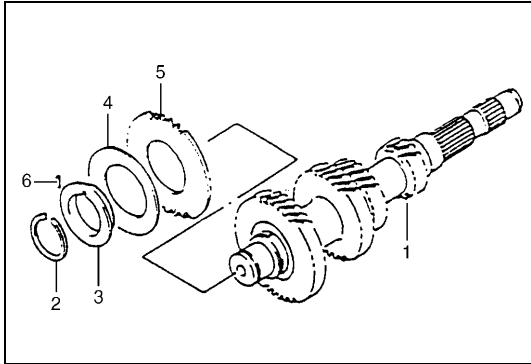

18) Remove circlip (2), friction gear retainer (3), friction gear spring (4), friction gear (5) and pin (6) from counter shaft (1) in that order.

SUB-ASSEMBLY

INPUT SHAFT

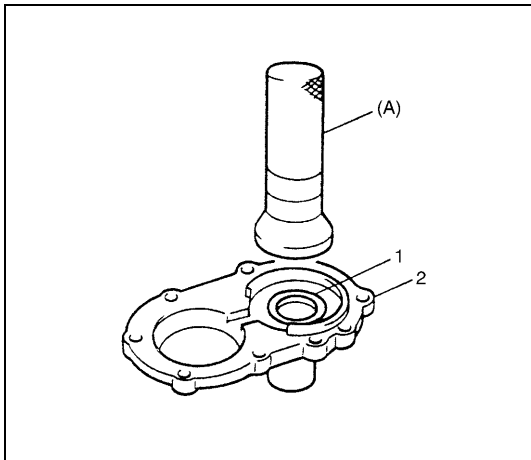

1) Take out oil seal (1) from input shaft oil seal retainer (2) and install new oil seal (1) with special tool and hammer up to case surface.

Unless oil seal (1) is leaky or its lip is excessively hardened, replacement is unnecessary.

Special tool
(A) : 09913-84510

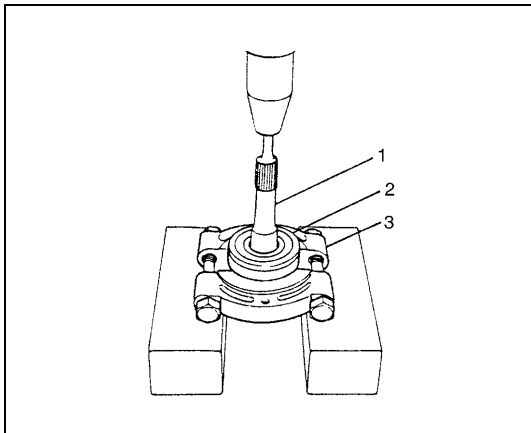

2) Remove circlip of input shaft (1) and pull out bearing (2) with bearing puller (3) and press as necessary.

NOTE:

Sealed bearing must not be washed. Replace it with new one when required.

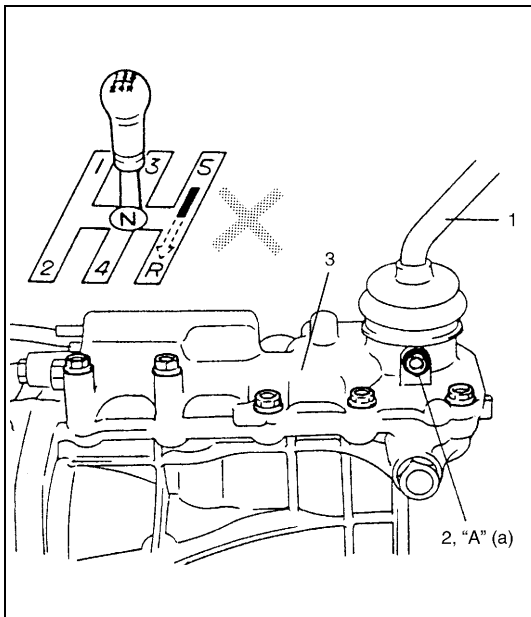
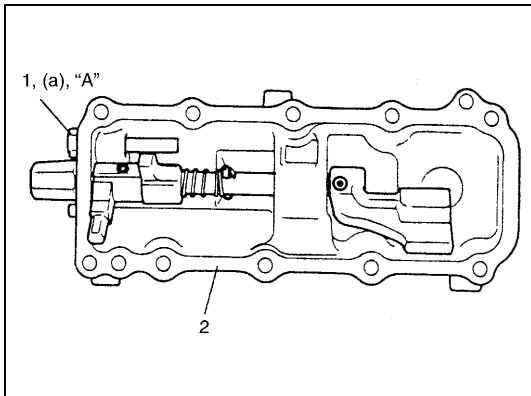
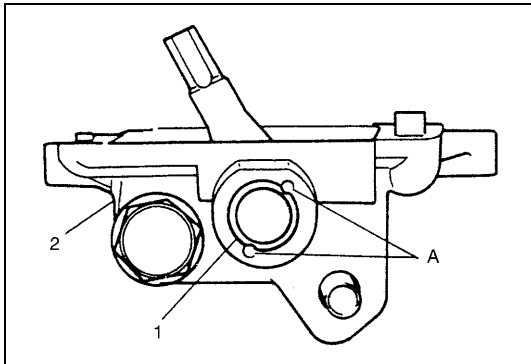
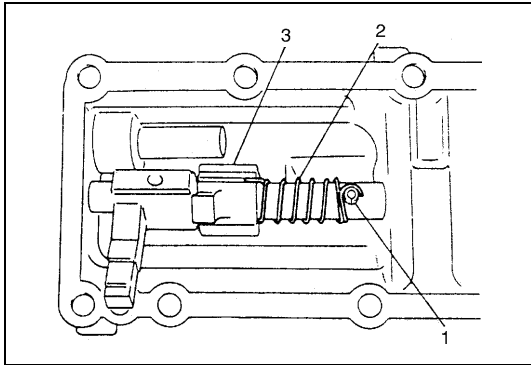

- 3) Drive in spring pin (single short) for reverse gear shift limit yoke.
- 4) Drive in spring pin (double) for shift lever.
- 5) Drive in spring pin (single long) for return spring.
- 6) Fit straight end of shift limit spring (2) into line groove in shift limit yoke (3) and with its other hooked end turned in its winding direction by about 90° from its free state, hook it on spring pin (1).
- 7) Drive in spring pin for shift arm.

- 8) Press-fit case plug (1) into case (2) and caulk it with punch.

"A" : Caulking

- 9) If reverse gear shift limit bolt (1) has been removed, apply thread lock cement "A" to bolt then install and torque it to specification.

"A" : Cement 99000-32020

Tightening torque

Reverse gear shift limit bolt (a) :
23 N·m (2.3 kg-m, 17.0 lb-ft)

2. Gear shift lever case

- 10) Install gear shift lever case (3) to transmission without using sealant for functional check.
- 11) Install shift control lever (1) and check to make sure that it shifts smoothly according to shift pattern as shown in the figure.

NOTE:

- Apply thread lock cement "A" to control lever locating bolts (2) when replaced.
- Be sure to apply sealant to mating surface of gear shift lever case (3) for its final installation.

"A" : Cement 99000-32020

Tightening torque

Control lever locating bolt (a) :
17 N·m (1.7 kg-m, 12.5 lb-ft)

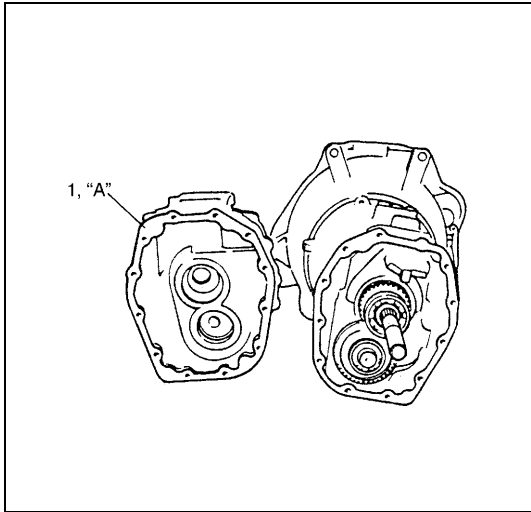

- 7) Clean mating surfaces of both cases, coat mating surface (1) of rear case with sealant evenly and mate it with transmission itself.

“A” : Sealant 99000-31110

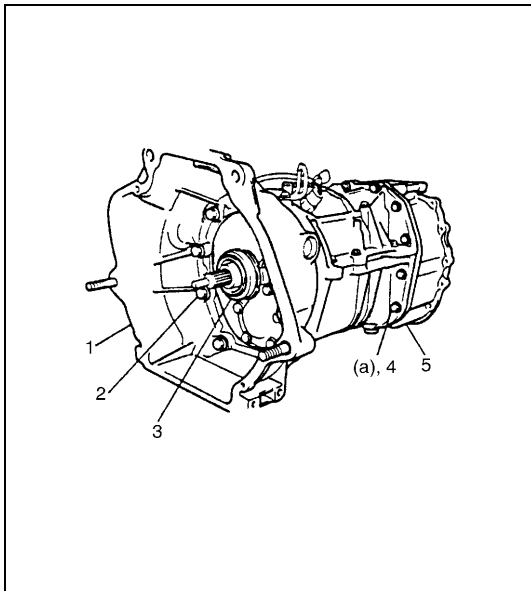

- 8) Install 12 rear case bolts and torque them to specification.

Tightening torque

Rear case bolt (a) : 23 N·m (2.3 kg-m, 17.0 lb-ft)

- | |
|---------------------------|
| 1. Clutch housing |
| 2. Bolt |
| 3. Clutch release bearing |
| 4. Bolt |
| 5. Rear case |

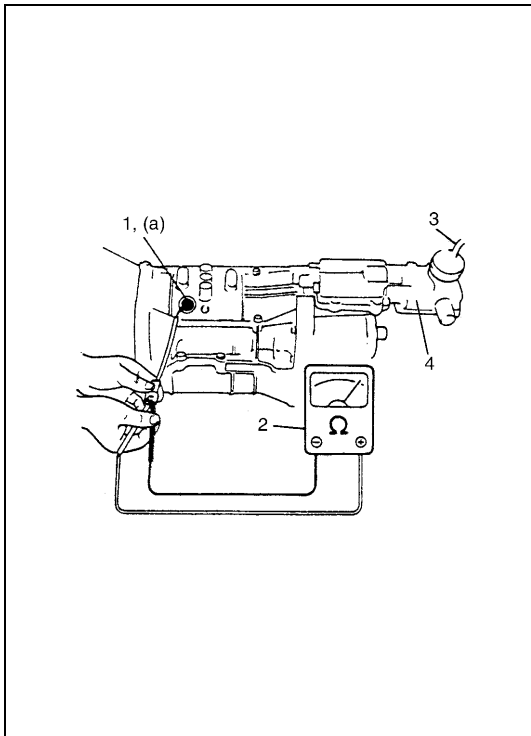

- 9) Install back up light switch (1).

Tightening torque

Back up light switch (a) : 20 N·m (2.0 kg-m, 14.5 lb-ft)

- 10) Install gear shift lever case (4) temporarily to confirm switch function by checking the following.

- Back up light switch (1) should conduct when gear shift control lever (3) is at reverse position.

- 11) After confirming switch function, remove gear shift lever case.

- | |
|-------------|
| 2. Ohmmeter |
|-------------|

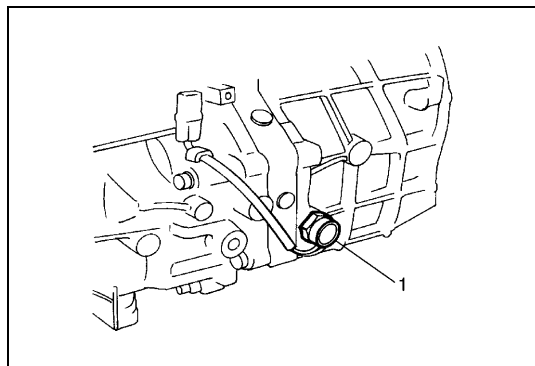

2) Remove back-up light switch (1).

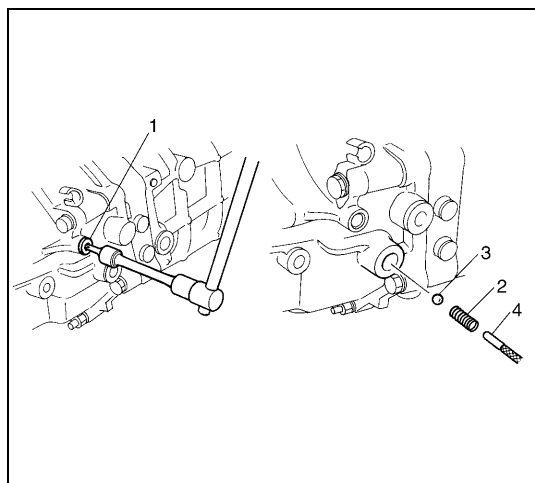

3) Remove locating screw (1), locating spring (2) and locating ball (3) as shown in the figure.

4. Magnet

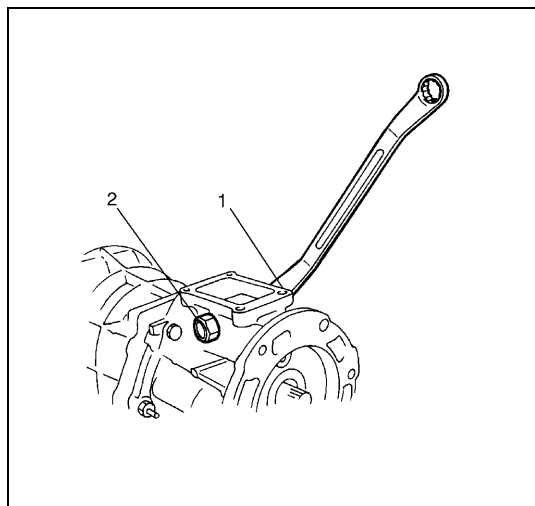

4) Remove return spring low bolt (1) and return spring reverse bolt (2).

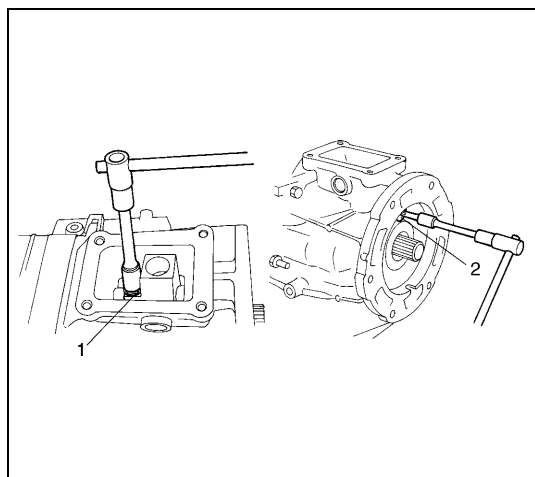

5) Remove gear shift shaft inner bolt (1)/plug (2).

INPUT SHAFT BEARING RETAINER AND OIL SEAL

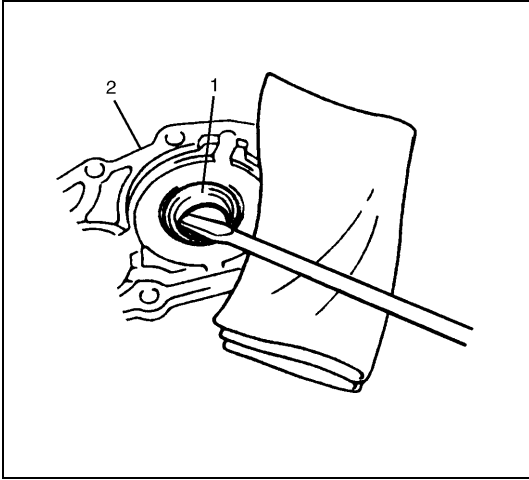

Remove oil seal (1) from bearing retainer (2) by using rod or the like as shown in the figure.

NOTE:

Unless oil seal is leaky or its lip is excessively hardened, replacement is not necessary.

TRANSMISSION REAR CASE

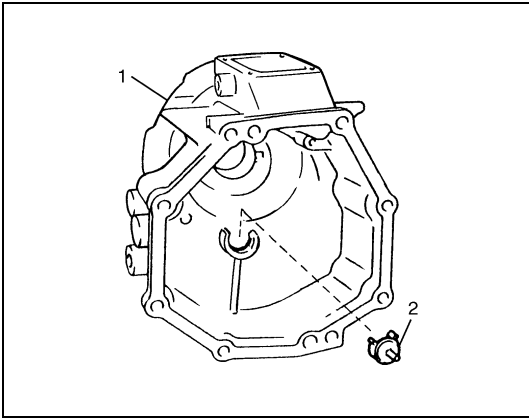

- 1) Remove counter shaft gutter (2) from transmission rear case (1).

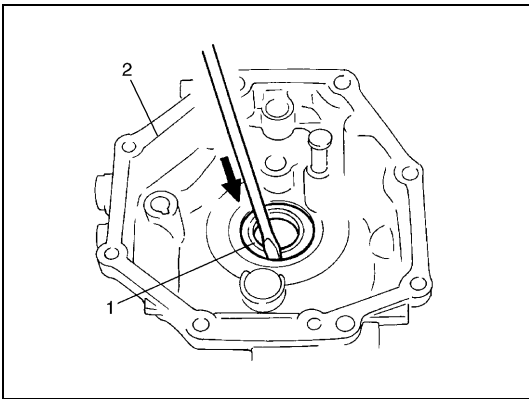

- 2) Take out oil seal (1) from rear case (2).

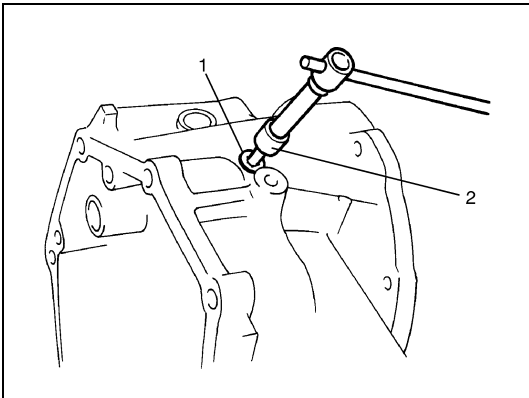

- 3) Remove interlock cam plug (1) by using torx® (2).

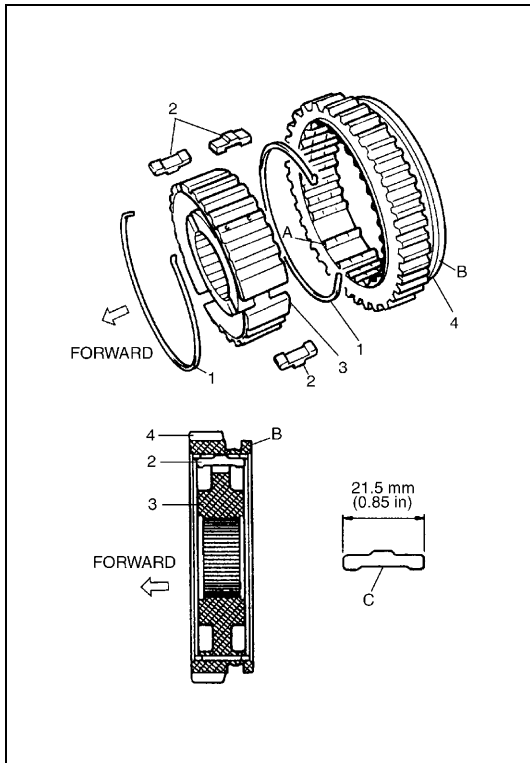

- 8) Assemble low speed synchronizer hub (3), sleeve (4), springs (1) and keys (2) according to the following procedure.
- Slide hub (3) in sleeve (4) with aligning hub slots with key location teeth of sleeve (4).
 - Insert keys (2) in hub slots with depression side of keys (2) face center of hub (3).
 - Install springs (1) to internal circle of key locations with spring end gaps apart at angles about 120 degrees each other, in order to apply spring tension equally to each key.

NOTE:

Before installing hub (3), sleeve (4), springs (1) and keys (2) assembly to main shaft, there is no specific installation direction on each component. However, when installing assembly to main shaft, gear side of sleeve (4) should face to forward direction as shown in the figure.

A :	Key location tooth
B :	Flange
C :	Depression of key

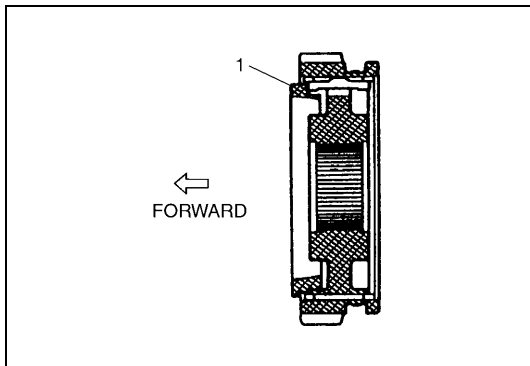

- 9) Install synchronizer ring (1) by matching its key slots to keys as shown in the figure.

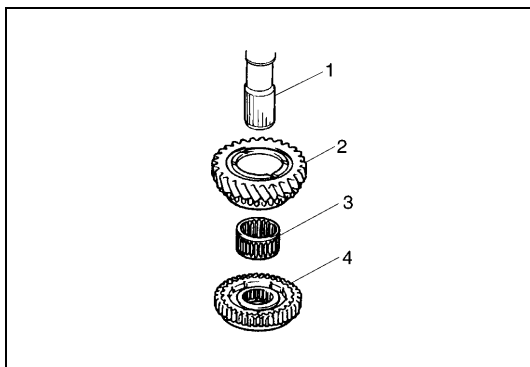

- 10) Insert 2nd gear (2), needle bearing (3) and low speed sleeve/hub assembly (4) with synchronizer ring to main shaft (1).

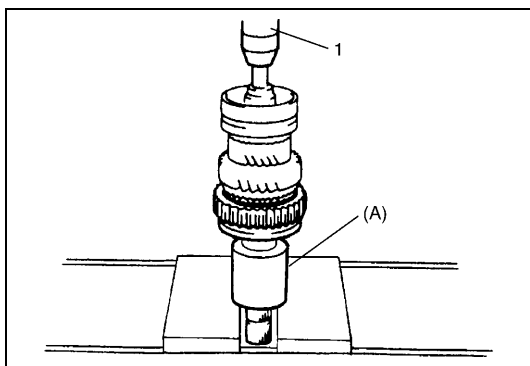

- 11) Press-fit low speed sleeve/hub assembly with special tool and press (1).

Special tool

(A) : 09940-53111

- 12) Check 2nd gear thrust clearance, referring to "MAIN SHAFT ASSEMBLY" in this section.

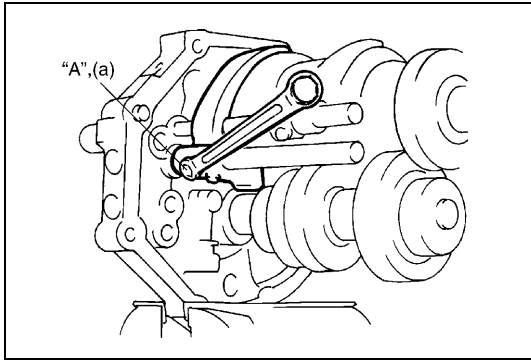

22) Apply thread lock cement "A" to thread of fork bolt and tighten bolt to specification.

"A" : Cement 99000-32020

Tightening torque

Shift fork bolt (a) : 20 N·m (2.0 kg-m, 14.5 lb-ft)

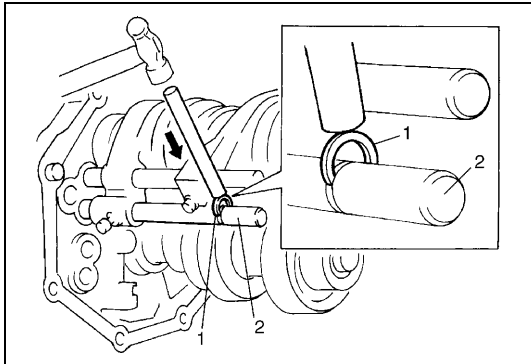

23) Fix with new circlip (1) to low gear shift shaft (2) by using lever or the like and hammer.

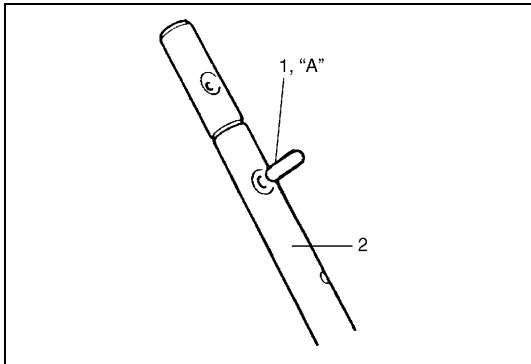

24) Apply grease to locating roller No.2 (1) and install roller (1) to reverse gear shift shaft (2).

"A" : Grease 99000-25010

25) Assemble reverse gear shift link assembly.

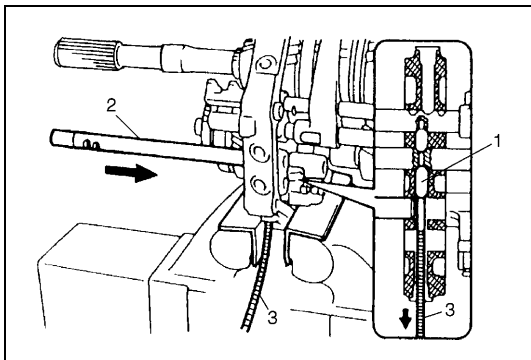

26) Insert reverse gear shift shaft (2) into reverse gear shift link assembly and intermediate case while holding locating roller No.1 (1) with magnet (3).

27) Supporting locating roller No.1 (1) with magnet (3), insert reverse gear shift shaft (2) into reverse gear shift link and intermediate case.

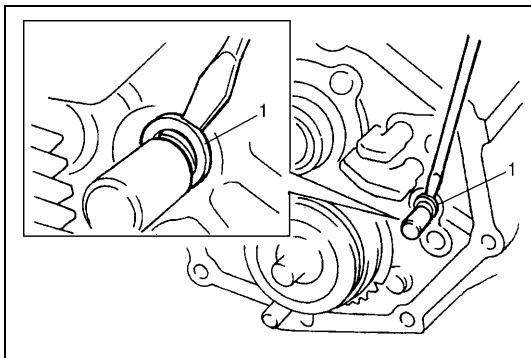

28) Fix with new circlip (1) to reverse gear shift shaft by using rod or the like and hammer.

GENERAL DESCRIPTION

When repairing automatic transmission, it is necessary to conduct the on-vehicle test to investigate where the cause of the trouble lies first.

Then whether overhaul should be done or not is determined. If the transmission is disassembled without such preliminary procedure, not only the cause of the trouble would be unknown, but also a secondary trouble may occur and often time would be wasted.

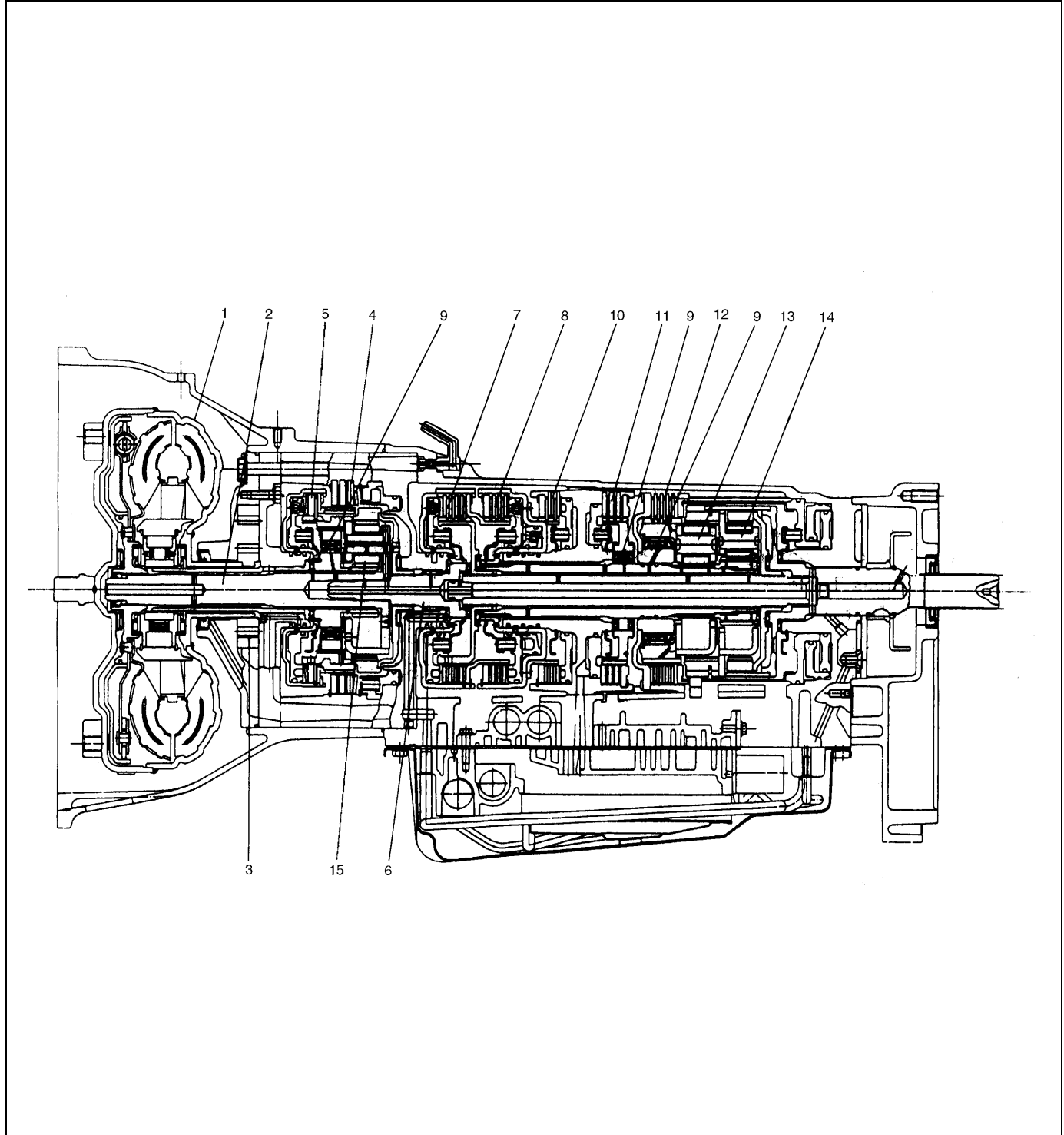

- | | | |
|--------------------------|-------------------------------|------------------------------|
| 1. Torque converter | 6. Forward clutch input shaft | 11. Second brake |
| 2. Overdrive input shaft | 7. Forward clutch | 12. Reverse brake |
| 3. Oil pump | 8. Direct clutch | 13. Front planetary gear |
| 4. Overdrive brake | 9. One-way clutch | 14. Rear planetary gear |
| 5. Overdrive clutch | 10. Second coast brake | 15. Overdrive planetary gear |

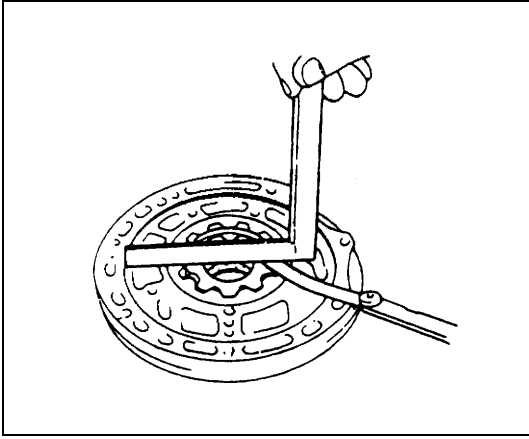

- Check side clearance between inner gear/outer gear and pump body.

Side clearance between inner gear/outer gear and pump body :

Standard : 0.02 – 0.05 mm (0.0008 – 0.0019 in.)

Service limit : 0.1 mm (0.0039 in.)

ASSEMBLY

Assemble each component by reversing removal procedure and noting following points.

- Before installing inner gear and outer gear to pump body, apply A/T fluid to them.
- When installing pump cover, use care so that its splined part will not cause damage to oil seal and use specified torque to tighten it to pump body.

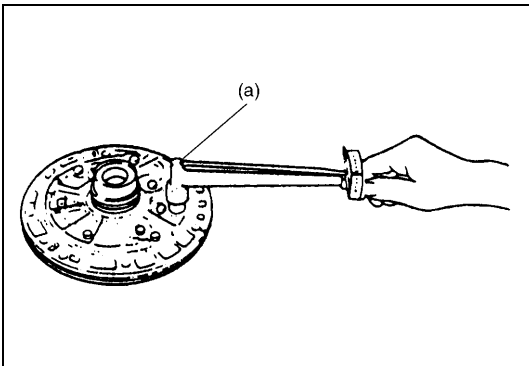

Tightening torque

Oil pump bolt (a) : 7.5 N·m (0.75 kg·m, 5.5 lb-ft)

- When installing O-ring and oil seal, apply enough A/T fluid to them and fit them securely in groove.
- After installation, check that inner gear turns smoothly by making use of torque converter.
- When installing seal ring, it should not be opened more than necessary.
- Fit claws of seal ring securely.

CLICK HERE TO **DOWNLOAD** THE COMPLETE MANUAL

- Thank you very much for reading the preview of the manual.
- You can download the complete manual from: www.heydownloads.com by clicking the link below



- Please note: If there is no response to CLICKING the link, please download this PDF first and then click on it.

CLICK HERE TO **DOWNLOAD** THE COMPLETE MANUAL

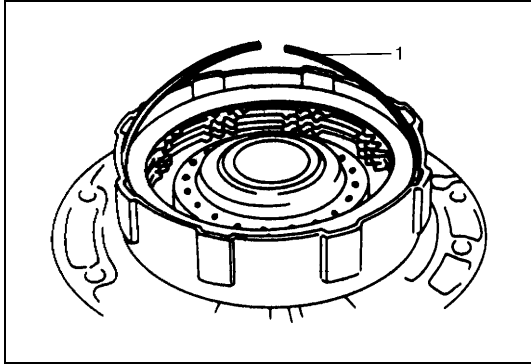

- 5) Remove retaining ring (1) and then remove direct clutch input hub.
- 6) Remove retaining ring and then remove all clutch discs.

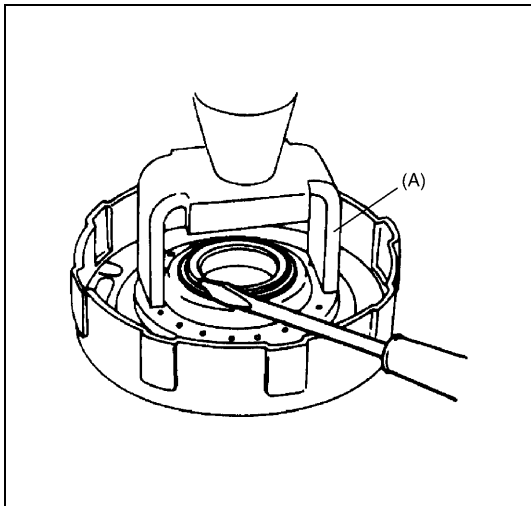

- 7) Using special tool and hydraulic press, compress forward clutch piston return spring and remove retaining return spring.

Special tool
(A) : 09926-98310

CAUTION:

Be careful when applying pressure, for overpressure will cause plate section of piston return spring to deform.

- 8) Remove forward clutch piston return spring.

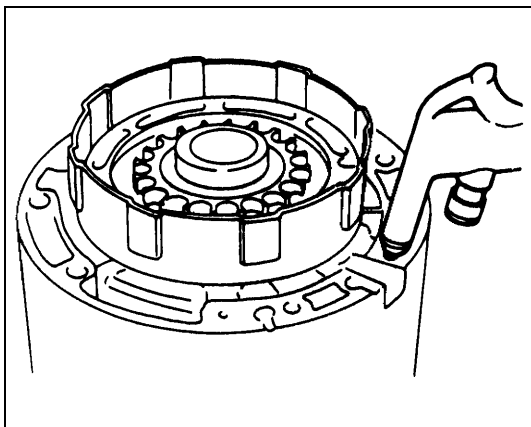

- 9) Install forward clutch to O/D case. Blow low pressure air into fluid hole at the right of cut in O/D case to remove forward clutch piston.

INSPECTION

Forward Clutch Piston

- Shake piston to check that ball is not stuck.
- Blow low pressure air to check ball section for leakage.

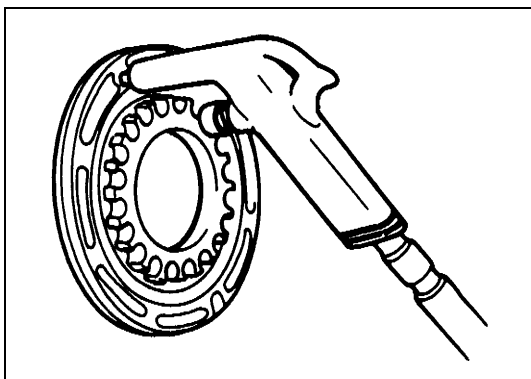

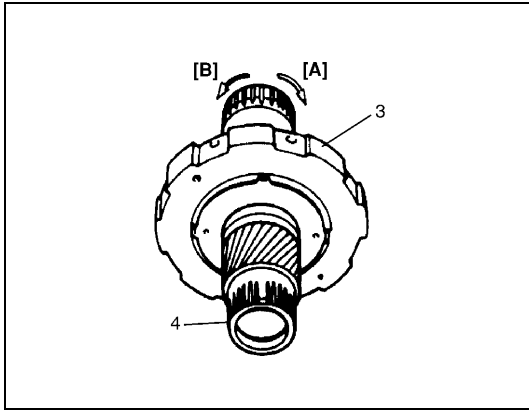

- 15) With B2 brake hub assembly (3) held stationary, turn planetary sun gear (4) clockwise to check that it locks and then counterclockwise to check that it turns smoothly.

[A]: Locks
[B]: Turns

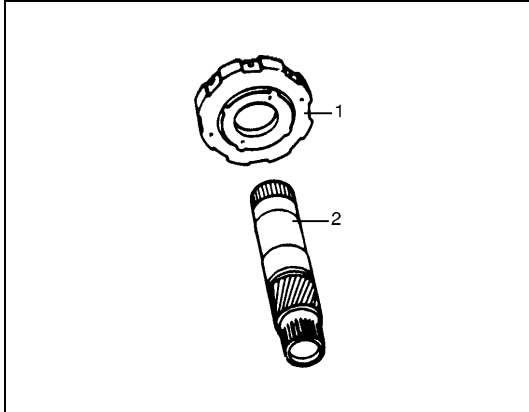

- 16) Remove B2 brake hub assembly (1) from planetary sun gear (2).

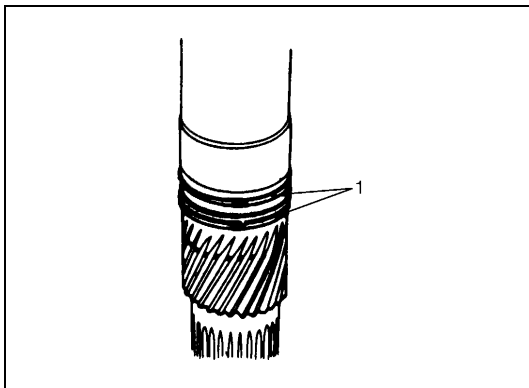

- 17) Remove 2 sun gear seal rings (1) from planetary sun gear.

NOTE:

Use care not to open sun gear seal ring more than necessary.

ASSEMBLY

Assemble components by reversing disassembly procedure and noting the following points.

- Snap both ends of sun gear seal ring (1) securely.
- Do not open sun gear seal ring more than necessary.
- Always use new O-ring and apply A/T fluid before installation.
- When installing O-ring, make sure that it is not kinked or caught.
- Push in brake piston horizontally.
- When installing brake piston return spring, be careful so that spring will not fall or tilt.

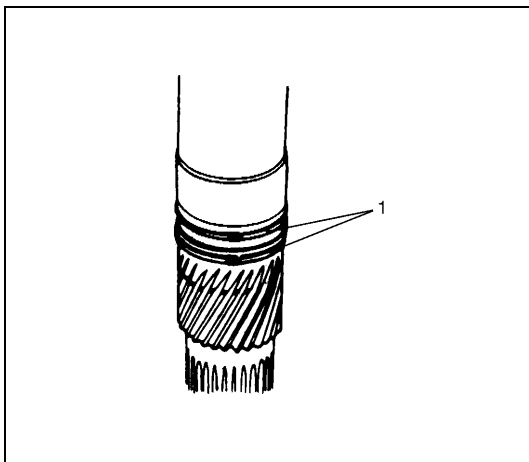

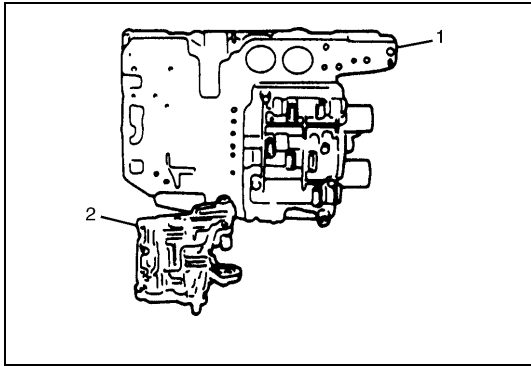

7) Install lower valve body assembly (1) on front upper valve body (2).

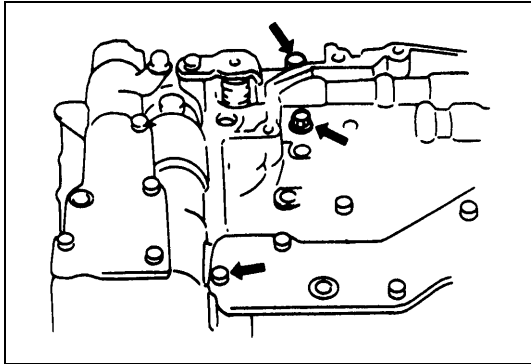

8) Tighten 3 bolts indicated in the figure temporarily.

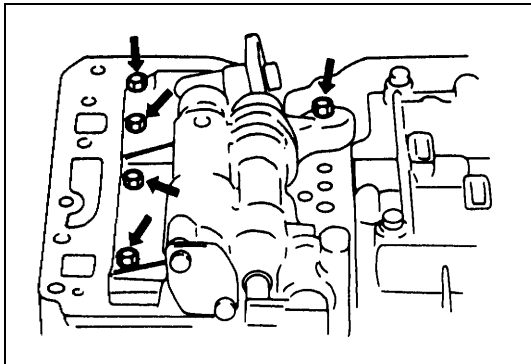

9) Turn over control valve lower body and tighten 5 bolts indicated in the figure temporarily.

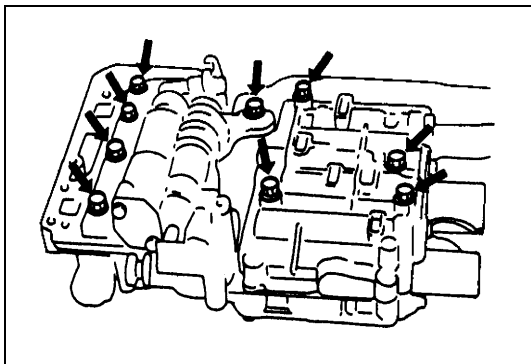

10) Tighten bolts on upper valve body side to specified torque.

Tightening torque

Upper valve body bolt : 5.5 N·m (0.55 kg-m, 4.0 lb-ft)

NOTE:

Tighten bolts by a certain amount of torque evenly and repeat it several times till specified torque is attained.

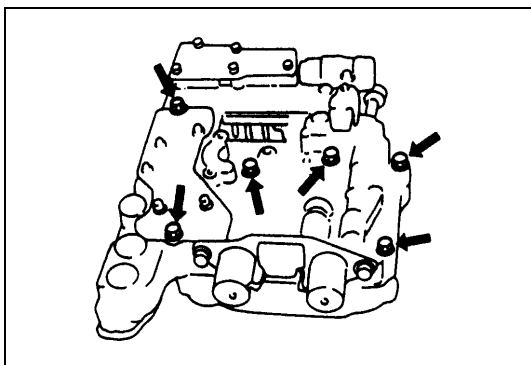

11) Tighten bolts on lower valve body inside to specified torque.

Tightening torque

Lower valve body bolt : 5.5 N·m (0.55 kg-m, 4.0 lb-ft)

NOTE:

Tighten bolts by a certain amount of torque evenly and repeat it several times till specified torque is attained.

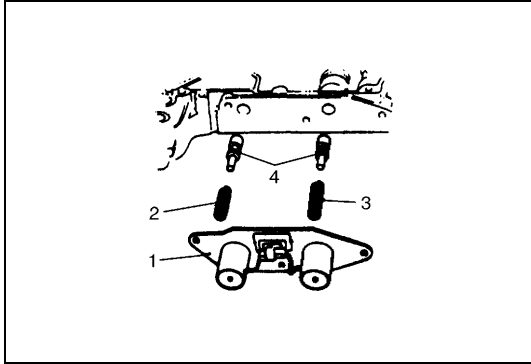

- 6) After removing shift solenoid valve (A & B) (1), remove solenoid valve gasket, low coast modulator valve spring (2), inter coast modulator valve spring (3) and 2 intermediate coast modulator valves (4).

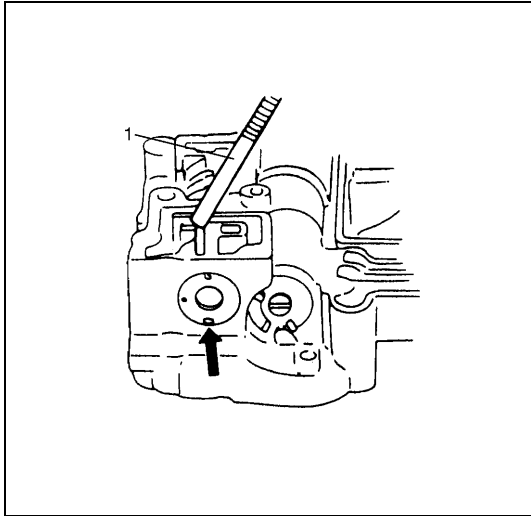

- 7) Pressing TCC (lock-up) control sleeve with finger and using magnet (1), remove locating pin and then remove TCC (lock-up) control sleeve, TCC (lock-up) control valve and TCC (lock-up) control valve spring.

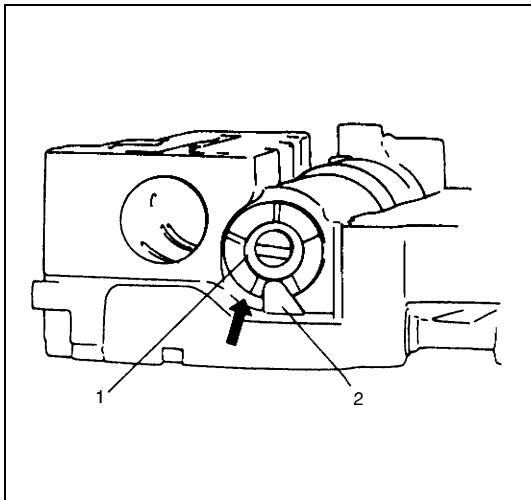

- 8) Check which step of primary regulator valve sleeve (1) (how many steps down from its tip) contacts primary regulator valve sleeve retainer (2).

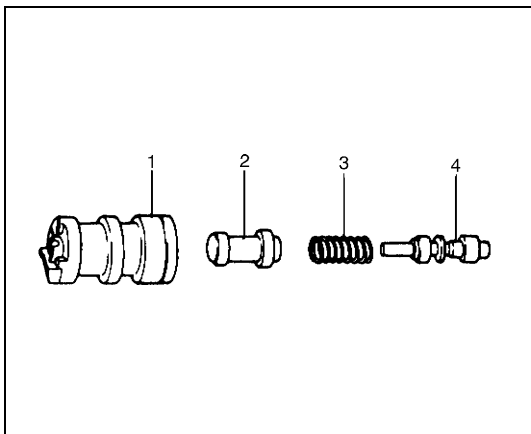

- 9) Pressing primary regulator valve sleeve (1) with finger and using magnet, remove primary regulator valve sleeve retainer and then remove primary regulator valve sleeve (1), primary regulator valve plunger (2), primary regulator valve spring (3) and primary regulator valve (4).

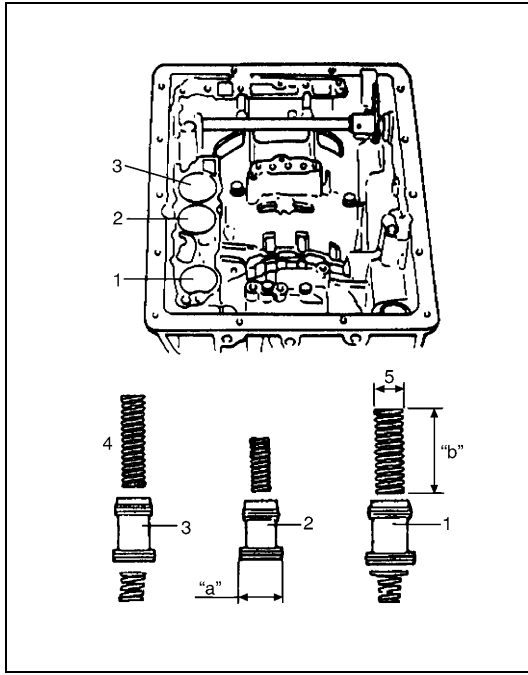

33) Apply A/T fluid to new O-ring and spring and install them to accumulator piston and install accumulator piston to transmission case.

- 4. Upper spring
- 5. Coil outer diameter

Accumulator piston and spring specification (G16 engine) :

Used for	Piston outer diameter "a"	Spring free length "b"	
		Upper spring	Lower spring
Direct clutch accumulator (2)	31.80 – 31.85 mm (1.252 – 1.254 in.)	Upper spring	61.21 mm (2.410 in.)
		Lower spring	–
Forward clutch accumulator (1)	31.80 – 31.85 mm (1.252 – 1.254 in.)	Upper spring	64.68 mm (2.546 in.)
		Lower spring	–
Second brake accumulator (3)	34.80 – 34.85 mm (1.370 – 1.372 in.)	Upper spring	55.18 mm (2.172 in.)
		Lower spring	35.13 mm (1.383 in.)

Accumulator piston and spring specification (J20 engine) :

Used for	Piston outer diameter "a"	Spring free length "b"	
		Upper spring	Lower spring
Direct clutch accumulator (2)	31.80 – 31.85 mm (1.252 – 1.254 in.)	Upper spring	59.82 mm (2.355 in.)
		Lower spring	–
Forward clutch accumulator (1)	31.80 – 31.85 mm (1.252 – 1.254 in.)	Upper spring	64.68 mm (2.546 in.)
		Lower spring	–
Second brake accumulator (3)	34.80 – 34.85 mm (1.370 – 1.372 in.)	Upper spring	55.18 mm (2.172 in.)
		Lower spring	35.13 mm (1.383 in.)

Accumulator piston and spring specification (H25 engine) :

Used for	Piston outer diameter "a"	Spring free length "b"	
		Upper spring	Lower spring
Direct clutch accumulator (2)	31.80 – 31.85 mm (1.252 – 1.254 in.)	Upper spring	43.56 mm (1.715 in.)
		Lower spring	30.80 mm (1.213 in.)
Forward clutch accumulator (1)	31.80 – 31.85 mm (1.252 – 1.254 in.)	Upper spring	64.68 mm (2.546 in.)
		Lower spring	–
Second brake accumulator (3)	34.80 – 34.85 mm (1.370 – 1.372 in.)	Upper spring	58.80 mm (2.135 in.)
		Lower spring	35.13 mm (1.383 in.)

UNIT REPAIR

DISASSEMBLY

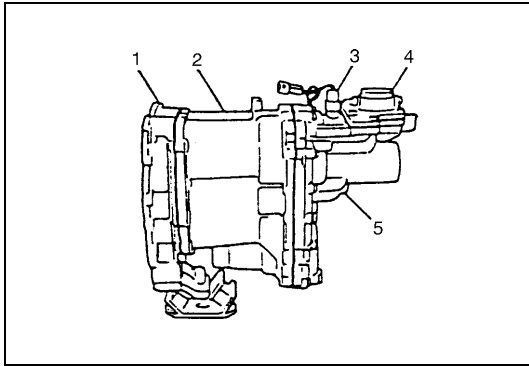

- 1) Remove 4WD switch (3) and take out steel ball.
- 2) Remove 5 bolts and then remove gear shift lever case (4).

- | |
|----------------|
| 1. Front case |
| 2. Center case |
| 5. Rear case |

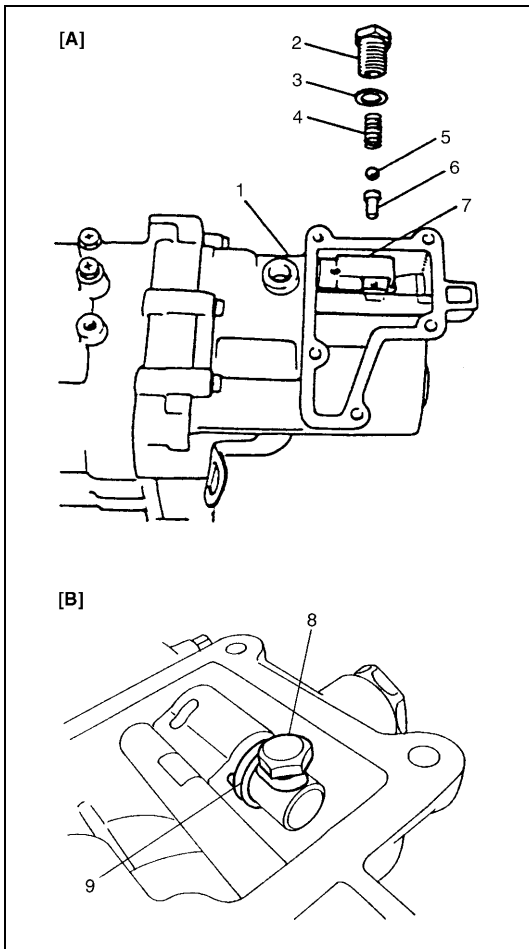

- 3) For transfer for A/T and TYPE 1 manual transmission, after removing bolt of select return system, take out spring (4), steel ball (5) and pin (6).

For transfer for TYPE 2 manual transmission, remove select return spring bolt (8) and then return spring (9).

[A]: For transfer for A/T and TYPE 1 manual transmission

[B]: For transfer for TYPE 2 manual transmission

- | |
|------------------------------|
| 1. Rear case |
| 2. Select return spring bolt |
| 3. Washer (aluminum) |
| 7. Reduction shift yoke |

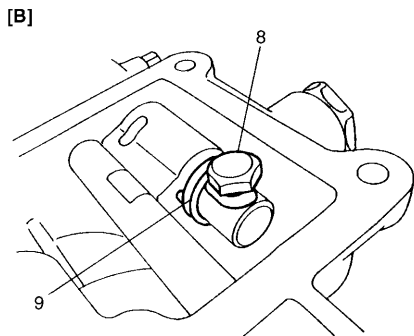

- 4) By hammering special tool, drive spring pin out of reduction shift yoke.

NOTE:

- Pin may drop into case when driven out. Therefore, take it out when case is disassembled.
- After spring pin is removed, yoke may be either taken out.

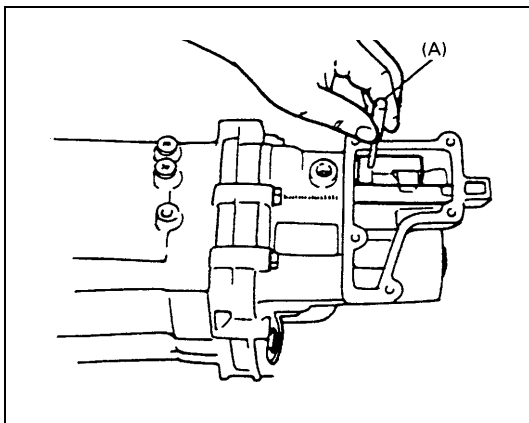

Special tool

(A) : 09922-85811

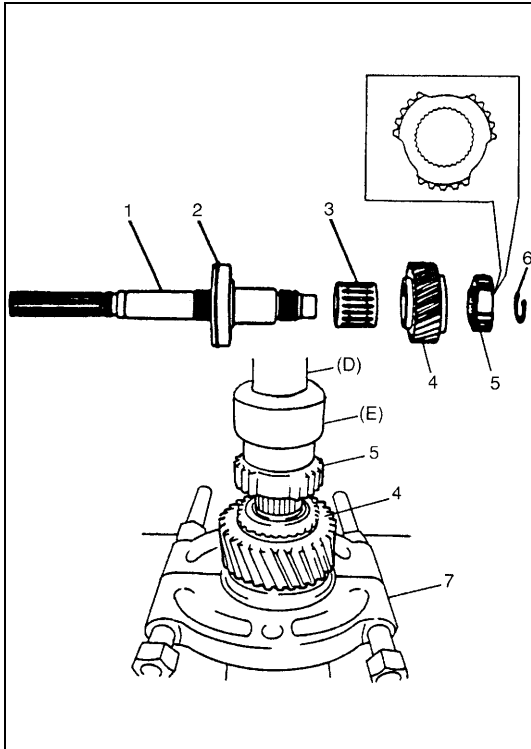

10) Install needle bearing (3) and output low gear (4) and then press-fit reduction clutch hub (5) onto output rear shaft (1) by using press and special tool and secure them with circlip (6). Hub has specific installing direction.

Special tool

(D) : 09925-18011

(E) : 09940-53111

- | |
|------------------|
| 2. Bearing No. 1 |
| 7. Puller |

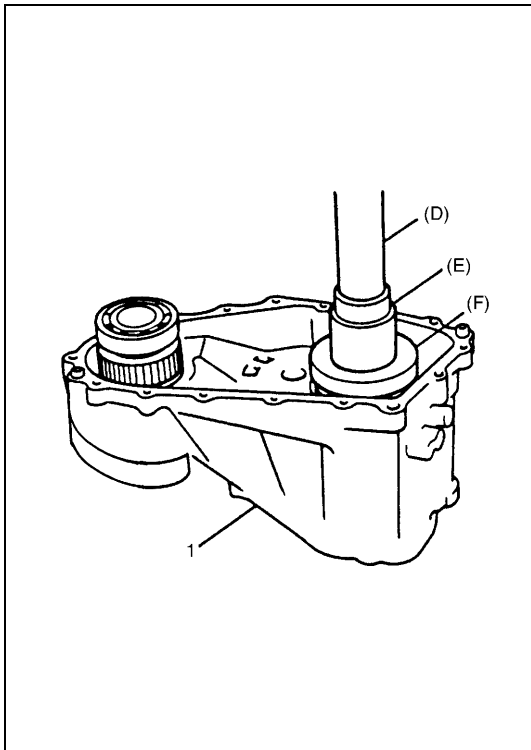

11) Combine special tools and press-fit output rear shaft assembly into center case (1).

NOTE:

Use special tool (F) with its under-cut side faced down (toward bearing).

Special tool

(D) : 09925-18011

(E) : 09940-53111

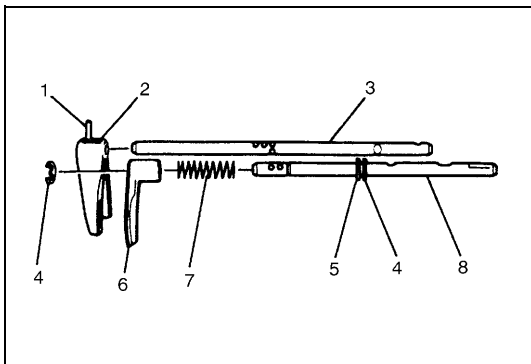

(F) : 09951-26010



12) Install fork to corresponding shift shaft.

- | |
|----------------------------|
| 1. Spring pin |
| 2. Reduction fork |
| 3. Reduction shift shaft |
| 4. Circlip |
| 5. Washer |
| 6. Front drive shift fork |
| 7. Spring |
| 8. Front drive shift shaft |

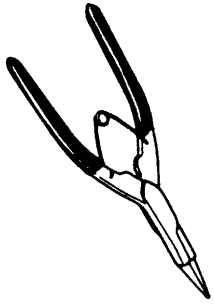
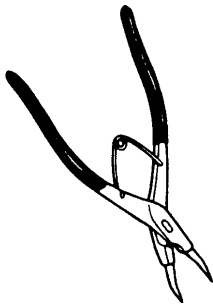
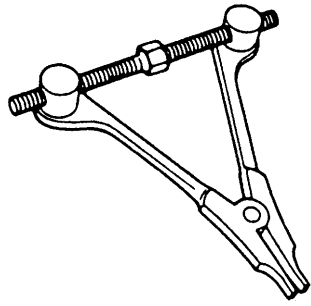
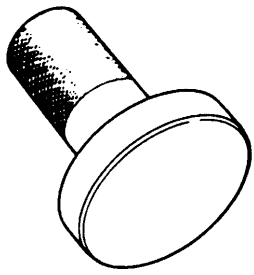
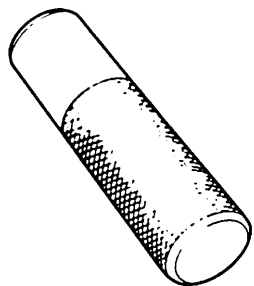
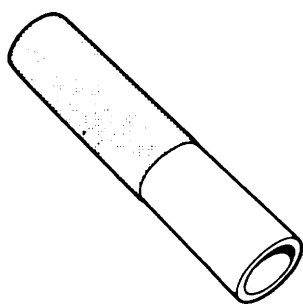
SPECIAL TOOL

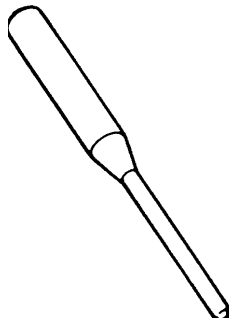
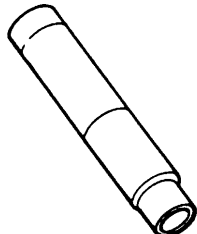
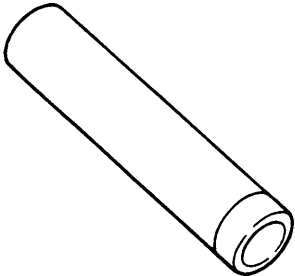
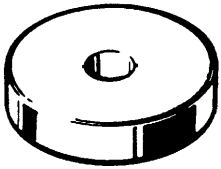
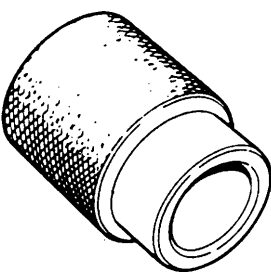
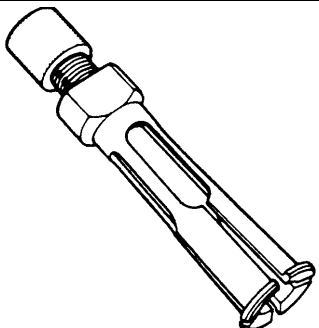
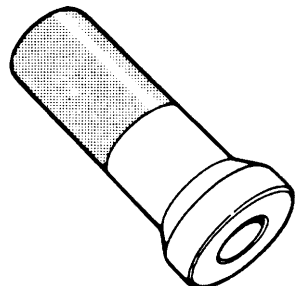
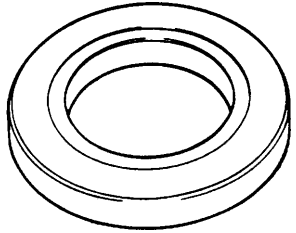
 <p>09900-06107 Snap ring plier (Opening type)</p>	 <p>09900-06108 Snap ring plier (Closing type)</p>	 <p>09912-34510 Separator</p>	 <p>09913-75520 Bearing installer</p>
 <p>09913-80112 Bearing installer</p>	 <p>09913-84510 Bearing installer</p>	 <p>09921-57810 Bearing remover</p>	 <p>09927-18411 Universal puller</p>
 <p>09922-85811 Spring pin remover</p>	 <p>09925-18011 Bearing installer</p>	 <p>09925-98221 Bearing installer</p>	 <p>09926-68310 Bearing installer</p>
 <p>09940-53111 Bearing installer</p>	 <p>09941-64511 Bearing remover</p>	 <p>09951-16080 Bearing installer</p>	 <p>09951-26010 Bush remover plate</p>

SUBASSEMBLY ADJUSTMENT AND REASSEMBLY

Judging from faulty conditions noted before disassembly and what is found through visual check of bearing and gear tooth etc. after disassembly, prepare replacing parts and proceed to reassembly according to procedures as described below.

CAUTION:

- Bevel gear and pinion must be replaced as a set when either replacement becomes necessary.
- When replacing taper roller bearing, replace as inner race & outer race assembly.

DIFFERENTIAL CARRIER

For press-fitting bevel pinion bearing outer races, use special tools as shown in the figure.

CAUTION:

Perform press-fitting carefully so as not to tilt outer race.

Special tool

(A) : 09924-74510

(B) : 09926-68310

(C) : 09913-75510

1. Differential carrier

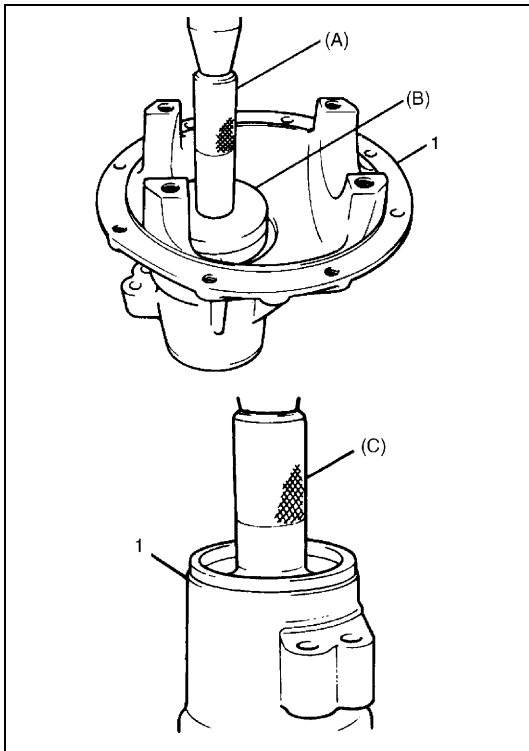

DIFFERENTIAL CASE

- 1) Install differential gears (3), free axle hub (4) and washers (2) to left case (7).
- 2) Install left case to right case (1) and tighten screws (8).

5. Differential pinion shaft

6. Differential pinion

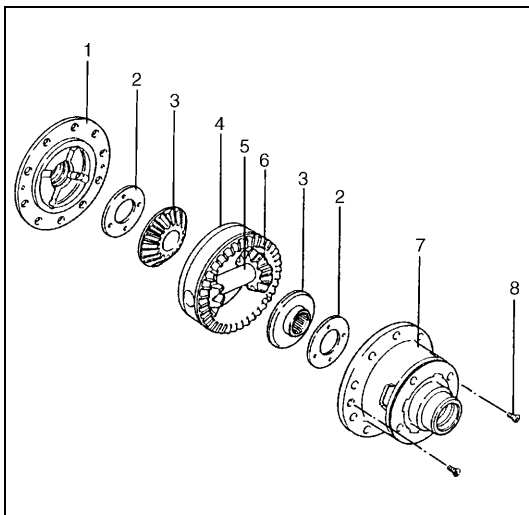

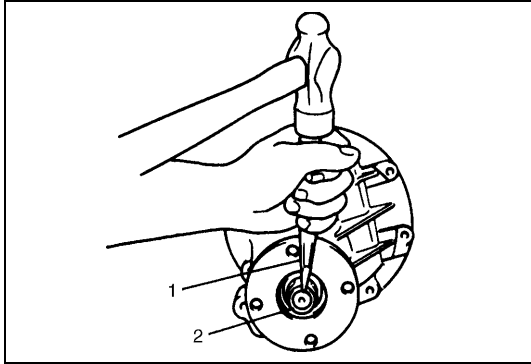

11) Upon completion of gear tooth contact check in step 9), caulk flange nut (2) with caulking tool (1) and hammer.

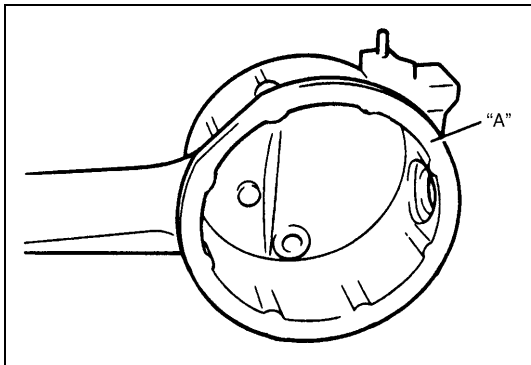

12) Clean mating surfaces of both housing and carrier and apply sealant "A" to housing side evenly.

"A" : Sealant 99000-31110

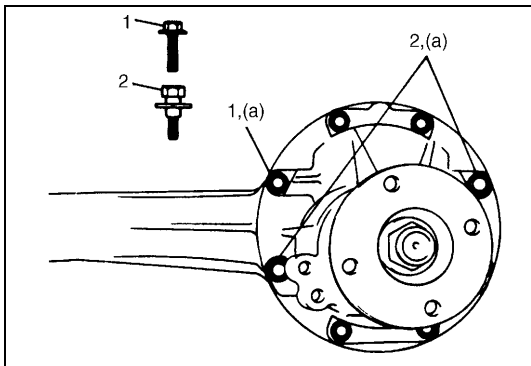

13) With differential assembly installed in housing, position it with 2 reamer bolts (2) and then install other 6 bolts (1).

14) Torque all bolts to specification.

Tightening torque

Differential carrier bolt (a) : 23 N·m (2.3 kg·m, 17.0 lb-ft)

15) Install front drive shaft.

TIGHTENING TORQUE SPECIFICATION

Fastening part	Tightening torque		
	N·m	kg·m	lb-ft
Air inlet union	13	1.3	9.5
Actuator bracket bolts	12	1.2	9.0
Bevel gear bolts	85	8.5	61.5
Bearing cap bolts	60	6.0	43.5
Lock plate bolts	13	1.3	9.5
Front differential carrier bolts	23	2.3	17.0

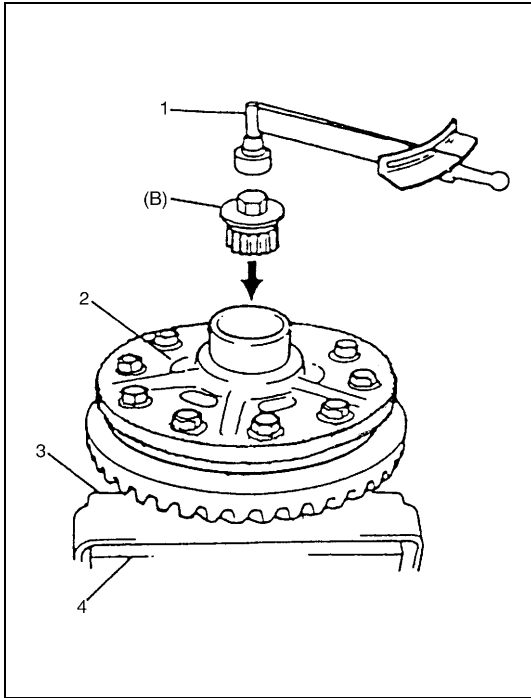

- 6) Install special tool to differential case assembly and check that preload is within specification below. If preload exceeds specified value, check if foreign matter is caught or gear is damaged.

Special tool

(B) : 09928-06010-002

Side gear preload :

Max. 2.5 N·m (0.25 kg·m, 1.8 lb·ft)

- | |
|-------------------------------|
| 1. Torque wrench |
| 2. Differential case assembly |
| 3. Aluminum plate |
| 4. Vise |

FOR 4 DIFFERENTIAL PINION TYPE

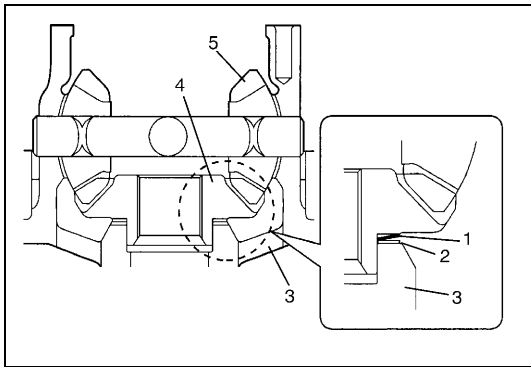

- 1) After applying differential oil to side gear (4), pinions (5), pinion shafts, washer, thrust washer (2) and spring washer (1), install them in differential left case (3).

For correct installing direction of thrust washer (2) and spring washer (1), refer to the figure.

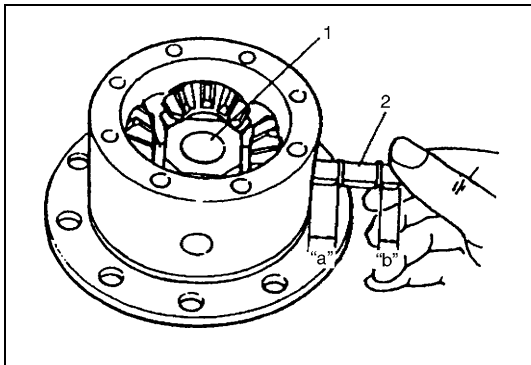

- 2) When installing pinion shaft No.2 (2) (shorter) into differential case and pinion, insert its "a" side into pinion joint (1).

NOTE:

"a" is longer than "b". ("a" > "b")

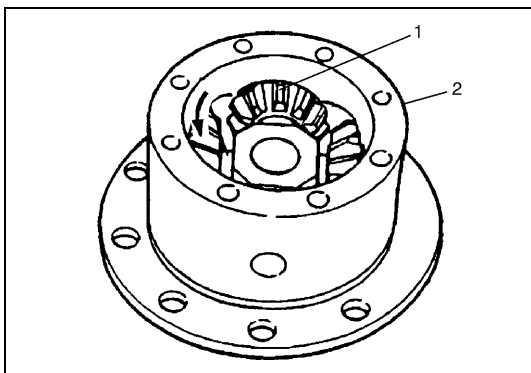

- 3) Check pinion gear (1) for smooth rotation.

- | |
|---------------------------|
| 2. Differential left case |
|---------------------------|

CLICK HERE TO **DOWNLOAD** THE COMPLETE MANUAL

- Thank you very much for reading the preview of the manual.
- You can download the complete manual from: www.heydownloads.com by clicking the link below



- Please note: If there is no response to CLICKING the link, please download this PDF first and then click on it.

CLICK HERE TO **DOWNLOAD** THE COMPLETE MANUAL