



Welcome to the TS3192EN Troubleshooting Manual. We make every effort to keep our service information current and accurate. Because of the time lag involved with writing and printing processes, the transmission TCM may report a code that has not yet been added to this document. If you encounter a code that is not yet in this publication, please call the Allison Transmission Technical Assistance Center at 1-800-252-5283.

**Go to the Table of Contents.**

CLICK HERE TO **DOWNLOAD** THE COMPLETE MANUAL

- Thank you very much for reading the preview of the manual.
- You can download the complete manual from: [www.heydownloads.com](http://www.heydownloads.com) by clicking the link below



- Please note: If there is no response to CLICKING the link, please download this PDF first and then click on it.

CLICK HERE TO **DOWNLOAD** THE COMPLETE MANUAL

## GENERAL DESCRIPTION

The TCM shift calibration determines the available forward ranges for each selector position. Although specific installations vary, typical selector positions for the 1000 and 2000 Product Families are:

**P** — Park. Parking pawl or parking brake is engaged, if available. This position is not available on all shift selectors.

**R** — Reverse.

**N** — Neutral. May be used when starting the engine and for stationary operations. The NSBU Switch disables the starter switch if a range other than **N** (Neutral) or **P** (Park) is selected before starting the vehicle.

**OD** — Overdrive. The highest forward range used for normal driving. The transmission shifts to first range for starting, then automatically upshifts through the ranges (as operating conditions permit) until the highest range is attained.

**D, 2, 1** — Forward Range. The transmission shifts to first range for starting. The range selected on the shift selector is the highest range which will be attained during automatic shifting.

### B. Manual Selector Valve

The manual shift selector shaft is attached to the manual selector valve within the transmission main control valve body. The selector valve has three positions: Reverse, Neutral, and Forward.

**NOTE: For transmissions equipped with a Park position, the selector valve remains in the Neutral position when the selector is moved to Park.**

The Neutral and Reverse selector valve positions (refer to Appendix H—Hydraulic Schematics) exhaust the C1 and C2 rotating clutches. By exhausting C1 and C2 clutches, forward range is inhibited. This provides the capability for the operator to override the electronically commanded ranges if **N** (Neutral) is required.

### C. NSBU Switch

The installation of a transmission-mounted neutral start/reverse signal switch is required. This switch, commonly called an “NSBU Switch” (Figure 1–5), mounts directly onto the transmission housing from the outside and detects the angular position of the shift selector shaft. This position is communicated to the TCM so that certain vehicle control functions can be coordinated with the position of the shift controls. The NSBU switch has redundant circuitry to alert the TCM in the event of a single wire or switch failure.

The neutral signal output of the NSBU switch is typically used as confirmation that the transmission is in **N** (Neutral) before the engine starter is engaged. The NSBU switch is interfaced to the starter circuit with weatherproof electrical connectors. The reverse signal provision may be used to activate vehicle back-up lights and/or reverse warning devices.

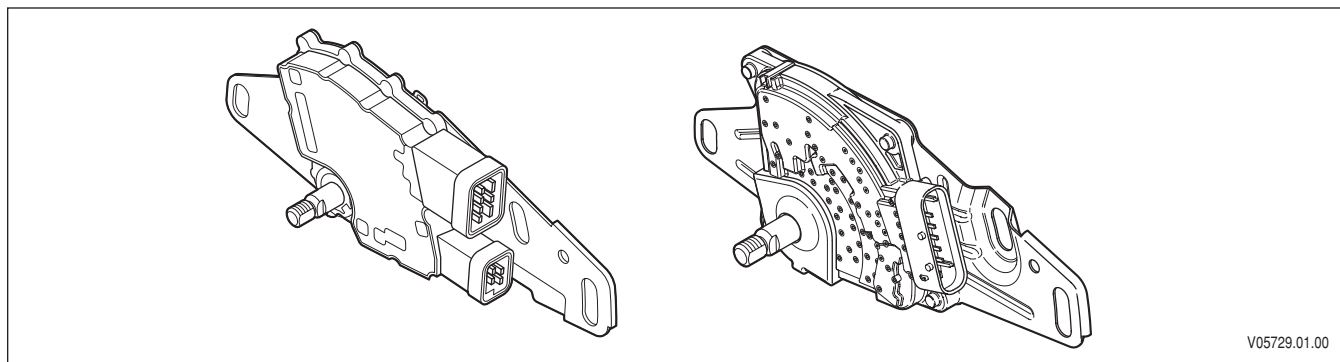

V05729.01.00

Figure 1–5. NSBU Switch

## DEFINITIONS AND ABBREVIATIONS

### 2-4. ABBREVIATIONS

A/N	<b>A</b> ssembly <b>N</b> umber
ABS	<b>A</b> nti-lock <b>B</b> rake <b>S</b> ystem—OEM-provided means to detect and prevent wheel stoppage to enhance vehicle handling. Retarder and engine brakes will not apply when ABS is active.
Amp	<b>A</b> mpere—Unit of electrical current
CAN	<b>C</b> ontroller <b>A</b> rea <b>N</b> etwork—A network for all SAE J1939 communications in a vehicle (engine, transmission, diagnostics, ABS, etc.)
CC	<b>C</b> alibration <b>C</b> ompatibility—First two digits of the CIN
CIN	<b>C</b> alibration <b>I</b> dentification <b>N</b> umber—Used to identify transmission controls software level
CT	<b>C</b> losed <b>T</b> hrottle
DNA	<b>D</b> oes <b>N</b> ot <b>A</b> dapt—Adaptive shift control is disabled.
DNS	<b>D</b> O <b>N</b> OT <b>S</b> HIFT—Refers to the <b>D</b> O <b>N</b> OT <b>S</b> HIFT diagnostic response during which the <b>C</b> HECK <b>T</b> RANS light is illuminated and the transmission will not shift and will not respond to the Shift Selector.
DTC	<b>D</b> iagnostic <b>T</b> rouble <b>C</b> ode
DVOM	<b>D</b> igital <b>v</b> olt/ <b>o</b> hmmeter
ECM	<b>E</b> ngine <b>C</b> ontroller <b>M</b> odule—Available on electronically-controlled engines—provides some relevant data to TCM.
EMI	<b>E</b> lectro <b>M</b> agnetic <b>I</b> nterference
GPI	<b>G</b> eneral <b>P</b> urpose <b>I</b> nterface—Input signal to the TCM to request a special operating mode or condition.
GPO	<b>G</b> eneral <b>P</b> urpose <b>O</b> utput—Output signal from the TCM to control vehicle components (such as PTOs, backup lights, etc.) or allow a special operating mode or condition.
IPC	<b>I</b> nstrument <b>P</b> anel <b>C</b> ontroller
J1939	High-speed vehicle serial data communications link.
LED	<b>L</b> ight- <b>E</b> mitting <b>D</b> iode—Electronic device used for illumination.
L RTP	<b>L</b> ow- <b>R</b> ange <b>T</b> orque <b>P</b> rotection—A feature limiting engine torque in lower ranges to protect the transmission from damage when a stall condition occurs.
NNC	<b>N</b> eutral <b>N</b> o <b>C</b> lutches—Neutral commanded with no clutches applied.
NSBU Switch	<b>N</b> eutral <b>S</b> tart <b>B</b> ackup <b>S</b> witch
NVL	<b>N</b> eutral <b>V</b> ery <b>L</b> ow—The TCM has sensed turbine speed below 150 rpm. This is usually caused by a dragging C1 or C3 clutch or a failed turbine speed sensor. When attained, the C4 and C5 clutches are applied to lock the transmission output.
OBD II	<b>O</b> n <b>B</b> oard <b>D</b> iagnosics <b>S</b> econd generation. EPA mandated specification for vehicle diagnostics.
OEM	<b>O</b> riginal <b>E</b> quipment <b>M</b> anufacturer—Maker of vehicle or equipment.
Ohm	Unit of electrical resistance.
PC	<b>P</b> ersonal <b>C</b> omputer
PCCS	<b>P</b> roduction <b>C</b> alibration <b>C</b> onfiguration <b>S</b> ystem
PCM	<b>P</b> owertrain <b>C</b> ontroller <b>M</b> odule—Electronic device used on some vehicles.
PDM	<b>P</b> arallel <b>D</b> ata <b>M</b> odule

## BASIC KNOWLEDGE

PCCS Load Station is used to reset Autoselect function, to do this it is necessary to clear all power-off data currently stored in the TCM.

- Go to the Maintenance button and select “Erase Power-off Data”
- After selecting “Erase Power-off data”, a message will indicate “PCCS is going to erase Power-off data”. Select “Yes”. Selecting “No” will abort the clearing of Power-off Data.
- After clearing Power-off Data, there will be a prompt to cycle the ignition.

The TCM is now reset to Autoselect and will start looking for supporting engine software.

Drive the vehicle; confirm DTCs have not returned.

**NOTE:** *Transmission shifts will now be in the unadaptive (base) state, so it will be necessary to drive the vehicle to allow shifts to converge.*

Autoselect reset function will be incorporated into the Allison DOC™ For PC service tool at a later date, along with an indication of the current SEM Autoselect status.

## DIAGNOSTIC TROUBLE CODES (DTC)

### 5-5. DIAGNOSTIC TROUBLE CODES (DTCs)

#### DTC LIST AND DESCRIPTION INDEX

DTC	Description	CHECK TRANS Light	Page
P0122	Pedal Position Sensor Circuit Low Voltage	Yes	5-16
P0123	Pedal Position Sensor Circuit High Voltage	Yes	5-20
P0218	Transmission Fluid Over Temperature Condition	No	5-24
P0561	Unrealistic Variations In Vehicle System Voltage	Yes	5-27
P0562	System Voltage Low	Yes	5-31
P0563	System Voltage High	Yes	5-34
P0602	TCM Not Programmed	Yes	5-37
P0606	Controller Internal Performance—Not enabled for Pickups or med duty “04”	Yes	5-38
P0614	Torque Control Data Mismatch—ECM/TCM	Yes	5-39
P0701	Transmission Control System Performance	No	5-41
P0703	Brake Switch Circuit Malfunction—GMT800 only	No	5-43
P0705†	Transmission Range Sensor Circuit (PNRDL input) Not production enabled/could be in development calcs	N/A	
P0706†	Transmission Range Sensor Circuit (Performance) Not production enabled/could be in development calcs	N/A	
P0708	Transmission Range Sensor Circuit High Input	Yes	5-46
P0710†	Transmission Fluid Temperature Sensor Circuit Not production enabled/could be in development calcs	N/A	
P0711	Transmission Fluid Temperature Sensor Circuit Performance	No	5-50
P0712	Transmission Fluid Temperature Sensor Circuit Low Input (High Temperature)	No	5-54
P0713	Transmission Fluid Temperature Sensor Circuit High Input (Low Temperature)	No	5-58
P0716	Turbine Speed Sensor Circuit Performance	Yes	5-62
P0717	Turbine Speed Sensor Circuit No Signal	Yes	5-65
P0719	Brake Switch ABS Input Low	N/A	5-69
P0721	Output Speed Sensor Circuit Performance	Yes	5-71
P0722	Output Speed Sensor Circuit No Signal	Yes	5-75
P0726	Engine Speed Input Circuit Performance	No	5-79
P0727	Engine Speed Input Circuit No Signal	No	5-82
P0731	Incorrect 1st Gear Ratio	Yes	5-85
P0732	Incorrect 2nd Gear Ratio	Yes	5-88
P0733	Incorrect 3rd Gear Ratio	Yes	5-91
P0734	Incorrect 4th Gear Ratio	Yes	5-94
P0735	Incorrect 5th Gear Ratio	Yes	5-97
P0736	Incorrect Reverse Ratio	Yes	5-100
P0741	Torque Converter Clutch System Stuck Off	Yes	5-104
P0742	Torque Converter Clutch System Stuck On	Yes	5-107
P0743	Torque Converter Clutch PWM Solenoid Circuit—Electrical (Previously P1860)	Yes	5-110
P0746	Solenoid A Controlled Clutch Stuck Off (Previously P1720)	Yes	5-115
P0747	Solenoid A Controlled Clutch Stuck On (Previously P1723)	Yes	5-118
P0748	Pressure Control Solenoid A Electrical	Yes	5-121
P0763	Shift Solenoid C Electrical	Yes	5-126

## DIAGNOSTIC TROUBLE CODES (DTC)

### DTC P0122 Pedal Position Sensor Circuit Low Voltage

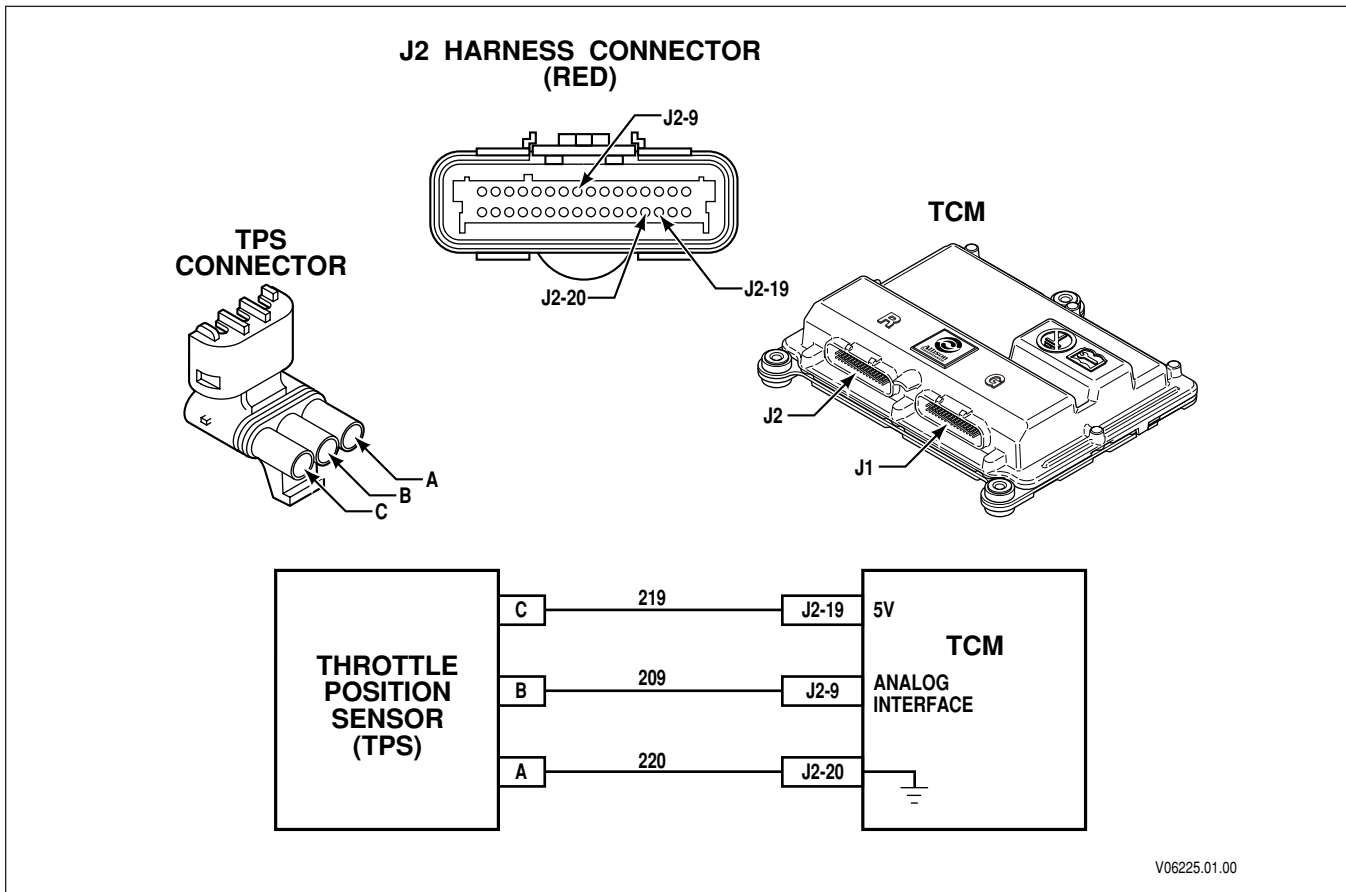

V06225.01.00

#### Circuit Description

The Transmission Control Module (TCM) receives input on throttle position from either a Throttle Position Sensor (TPS) or a signal transmitted by the engine electronic controls.

Vehicles not equipped with electronically-controlled engines have a TPS attached to the engine fuel control linkage. The TPS continuously sends the exact throttle position to the transmission TCM.

The TPS is a sliding resistor sensor (potentiometer) actuated by a mechanical linkage. The TCM delivers a constant voltage to one terminal of the TPS resistive strip. The other TPS terminal connects to ground. The resistor contacts of the TPS are connected to provide a regulated voltage signal input to the TCM.

When actuated by the mechanical throttle cable, the contacts of the resistor move along the resistive strip. As the contacts slide along the resistive strip, a voltage is sent to the TCM. At each increment of 0.178 mm (0.007 inch) along the resistive strip, the contacts deliver a different voltage to the TCM. The different voltages are interpreted as throttle sensor movement. The TCM converts travel distance (mm) into throttle opening percentage.

#### Conditions for Running the DTC

- The components are powered and ignition voltage is greater than 9V and less than 18V (12V TCM) or greater than 18V and less than 32V (24V TCM).
- DTC P0123 Pedal Position Sensor Circuit High Voltage is not active.

## DIAGNOSTIC TROUBLE CODES (DTC)

### DTC P0218 Transmission Fluid Over Temperature Condition *(cont'd)*

Step	Action	Yes	No
2	<ol style="list-style-type: none"> <li>1. Install the Scan Tool.</li> <li>2. Turn ON the ignition, with the engine OFF.</li> <li>3. Record the Failure Record data.</li> <li>4. Clear the DTC.</li> <li>5. Perform the A/T Fluid Checking Procedure (Appendix P).</li> </ol> Was the A/T fluid level check performed?	<i>Go to Step 3</i>	<i>Go to A/T Fluid Checking Procedure. (Appendix P)</i>
3	<ol style="list-style-type: none"> <li>1. Inspect the engine cooling system for the following conditions:                             <ul style="list-style-type: none"> <li>• Air flow restrictions</li> <li>• Air flow blockage</li> <li>• System fluid level and condition</li> <li>• Debris</li> </ul> </li> <li>2. Inspect the transmission cooling system for the following conditions:                             <ul style="list-style-type: none"> <li>• Air flow restrictions</li> <li>• Air flow blockage</li> <li>• System fluid level and condition</li> <li>• Debris</li> <li>• Damaged cooler lines or hoses</li> </ul> </li> </ol> Did you find and correct the condition?	<i>Go to Step 6</i>	<i>Go to Step 4</i>
4	Perform the Main Pressure Check Procedure. Refer to Appendix B. Did you find and correct a pressure problem?	<i>Go to Step 6</i>	<i>Go to Step 5</i>
5	Check for a possible torque converter stator malfunction. A stuck stator would be indicated by no cool-down in neutral after stalling the transmission. Refer to Section 7. Did you find and correct the condition?	<i>Go to Step 6</i>	<i>Go to General Troubleshooting (Section 7)</i>
6	Perform the following procedure in order to verify your repair: <ol style="list-style-type: none"> <li>1. Clear the DTC.</li> <li>2. Using the Scan Tool, monitor the transmission fluid temperature.</li> <li>3. Operate the vehicle under the following conditions.</li> <li>4. Turn ON the ignition, with the engine OFF.</li> <li>5. The TFT must be less than 126°C (258°F) for at least 10 seconds.</li> <li>6. Using the Scan tool, verify that the test to detect this code has run.</li> </ol> Has the test run and passed?	<i>Begin the diagnosis again.</i> <i>Go to Step 1</i>	<i>System OK</i>

## DIAGNOSTIC TROUBLE CODES (DTC)

### DTC P0563 System Voltage High *(cont'd)*

Step	Action	Value(s)	Yes	No
2	1. Install the Scan Tool. 2. Turn ON the ignition, with the engine OFF. 3. Record the failure records. 4. Clear the DTC. 5. Start vehicle engine and inspect the ignition voltage value on the Scan Tool.  <b>NOTE: This DTC sets when ignition voltage is detected above 18V for 12V systems or 32V for 24V systems for 6 out of 10 seconds.</b>  Is the ignition voltage above specified value?	See Conditions for Setting the DTC	<i>Go to Step 4</i>	<i>Go to Step 3</i>
3	1. Start the vehicle, if possible. 2. If the DTC is not active, drive the vehicle. Attempt to duplicate the same operating conditions observed in failure records. Did the DTC return?	—	<i>Go to Step 4</i>	<i>Go to Diagnostic Aids</i>
4	Test the vehicle charging system per the OEM recommended testing procedure. Is the charging system operating properly?	—	<i>Go to Diagnostic Aids</i>	<i>Repair the charging system and go to Step 5</i>
5	In order to verify your repair: 1. Clear DTC. 2. Drive vehicle under conditions shown in failure records when DTC set. Did the DTC return?	—	<i>Begin the diagnosis again. Go to Step 1</i>	<i>System OK</i>

## DIAGNOSTIC TROUBLE CODES (DTC)

### DTC P0708 Transmission Range Sensor Circuit High Input

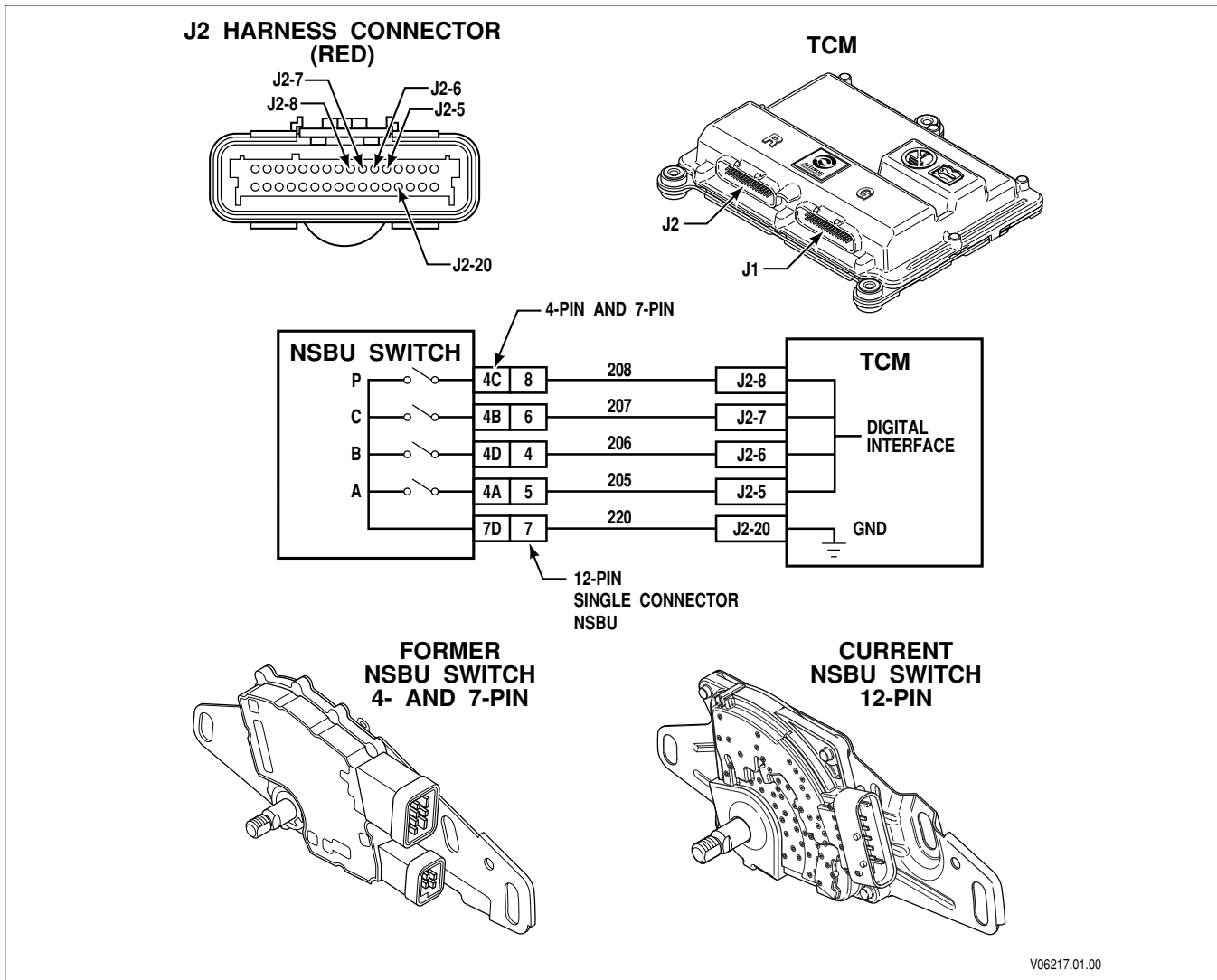

#### Circuit Description

The installation of a transmission-mounted Neutral Start/Back-Up (NSBU) switch is required. This switch mounts directly onto the transmission housing from the outside and detects the angular position of the shift selector shaft. This position is communicated to the Transmission Control Module (TCM) so that certain vehicle control functions can be coordinated with the position of the shift controls. The NSBU switch has redundant circuitry to alert the TCM in the event of a single wire or switch failure.

The neutral signal output of the NSBU switch is typically used as confirmation that the transmission is in **N** (Neutral) before the engine starter is engaged. The NSBU switch is interfaced to the starter circuit with weatherproof electrical connectors. The reverse signal provision may be used to activate vehicle back-up lights and/or reverse warning devices.

#### Conditions for Running the DTC

- The components are powered and ignition voltage is greater than 9V and less than 18V.
- Engine speed is greater than 200 rpm and less than 7500 rpm for 5 seconds.

## DIAGNOSTIC TROUBLE CODES (DTC)

### DTC P0712 Transmission Fluid Temperature Sensor Circuit Low Input (High Temperature)

Step	Action	Value(s)	Yes	No
1	Was the <b>Beginning The Troubleshooting Process</b> (Paragraph 5–4A) performed?	—	<i>Go to Step 2</i>	<i>Go to Beginning The Troubleshooting Process (Paragraph 5–4A)</i>
2	Perform the A/T Fluid Checking Procedure (Appendix P). Is the transmission fluid level correct?	—	<i>Go to Step 3</i>	<i>Go to A/T Fluid Checking Procedure (Appendix P)</i>
3	1. Turn the ignition OFF. 2. Disconnect J2 connector at the TCM and install J 39700 Breakout Box and J 43799 Breakout Box Adapter at J2 connector. 3. With the engine OFF, turn the ignition to the ON position. Measure voltage at J2 connector pins 10 and 20. Is voltage within the specified value?	4.75–5.25V	<i>Go to Step 4</i>	<i>Go to Step 11</i>
4	1. Install the Scan Tool. 2. With the engine OFF, turn the ignition to the ON position. 3. Record the Failure Record data. 4. Clear the DTC. 5. Select TFT on the Scan Tool. Drive the vehicle and inspect for unrealistic TFT readings. Is the TFT reading at or above the specified value? This DTC may indicate a short to ground at wire 210.	150°C (302°F)	<i>Go to Step 5</i>	<i>Go to Diagnostic Aids</i>
5	1. Disconnect the wiring harness from the main transmission connector. 2. Using a DVOM, measure resistance at main transmission connector pins G and H.* Is resistance within the specified values?	3398–3582 Ohms at 20°C (68°F) <i>Refer to TFT Sensor Resistance Table Page 5–13)</i>	<i>Go to Step 6</i>	<i>Go to Step 8</i>
6	1. Reconnect the wiring harness to the main transmission connector. 2. Disconnect J2 connector from the TCM. 3. Using a DVOM, measure resistance at J2 connector pins 10 and 20. Is the resistance within the specified values?	3398–3582 Ohms at 20°C (68°F) <i>Refer to TFT Sensor Resistance Table Page 5–13)</i>	<i>Go to Diagnostic Aids</i>	<i>Go to Step 7</i>

## DIAGNOSTIC TROUBLE CODES (DTC)

- When unrealistic low turbine speed is detected.
  - Engine is running.
  - Shift is not in process.
  - Range attained is not neutral.
  - Transmission fluid temperature is above  $-25^{\circ}\text{C}$  ( $-13^{\circ}\text{F}$ ).
  - Transmission output speed is at or above 150 rpm or engine speed is at or above 400 rpm.

### Conditions for Setting the DTC

DTC P0717 is set when one of the following conditions occur:

- Unrealistic large change in turbine speed. A Failure pending is set if an unrealistic change in transmission turbine speed is detected at or above 800 rpm. The failure pending response is to lock in the current range.
- Unrealistic low value in turbine speed. A failure pending is set if turbine speed is detected below 61 rpm. A failure is set when turbine speed is below 61 rpm and output speed is detected above 500 rpm for more than 1 second.

### Action Taken When the DTC Sets

- When DTC P0717 is active, the following conditions will occur:
  - If failure occurs while in a forward range and a shift has been completed, the transmission will remain in the current range.
  - If failure occurs while in a forward range and a shift is in progress, the transmission will return to the previous range, except in post-shift state; then the transmission will continue to the commanded range.
  - If failure occurs under other conditions, the transmission shifts to 1st, 3rd, or 5th.
  - If the shift selector is moved to **N** (Neutral), **R** (Reverse), or any other forward range, the transmission will lock in **N** (Neutral).
- DTC P0717 is stored in the TCM history.
- The **CHECK TRANS** light illuminates.
- The TCM freezes shift adapts (DNA).
- The TCM inhibits TCC engagement.

### Conditions for Clearing the DTC/CHECK TRANS Light

A Scan Tool may be used to clear the code from the TCM history. The TCM automatically clears the DTC from the TCM history if the vehicle completes 40 warm-up cycles without the DTC recurring.

### Diagnostic Aids

- Inspect the wiring for poor electrical connections at the TCM. Look for the following conditions:
  - A bent terminal.
  - A backed-out terminal.
  - A damaged terminal.
  - Poor terminal tension.
  - A chafed wire.
  - A broken wire inside the insulation.
- You may have to drive the vehicle in order to experience a fault.

## DIAGNOSTIC TROUBLE CODES (DTC)

- When unrealistically low output speed is detected.
  - Engine is running.
  - Shift is not in process.
  - Range attained is not neutral.
  - Transmission fluid temperature is above  $-25^{\circ}\text{C}$  ( $-13^{\circ}\text{F}$ ).
  - Transmission turbine speed is at or above 1050 rpm.
  - Manual selector valve is not being moved to a forward range.

### Conditions for Setting the DTC

DTC P0722 is set when one of the following conditions occur:

- Unrealistic large change in output speed. A failure pending is set if an unrealistic change in transmission output speed is detected at or above 600 rpm. A failure is set if neutral range is attained.
- Unrealistic low value in output speed. A failure pending is set if output speed is detected below 61 rpm. A failure is set when output speed is below 61 rpm and transmission range is 3rd, 4th, or 5th for more than 1 second.

### Action Taken When the DTC Sets

- When DTC P0722 is active, the following conditions will occur:
  - If failure occurs while in a forward range and a shift has been completed, the transmission will remain in the current range.
  - If failure occurs while in a forward range and a shift is in progress, the transmission will return to the previous range, except in post-shift state; then the transmission will continue to the commanded range.
  - If failure occurs under other conditions, the transmission shifts to 1st, 3rd, or 5th.
  - If the shift selector is moved to **N** (Neutral), **R** (Reverse), or any other forward range while the diagnostic response is active, the transmission will lock in **N** (Neutral).
  - If a latched inhibit is present, the transmission locks in neutral.
- DTC P0722 is stored in the TCM history.
- The **CHECK TRANS** light illuminates.
- The TCM freezes shift adapts (DNA).
- The TCM inhibits TCC engagement.

### Conditions for Clearing the DTC/CHECK TRANS Light

A Scan Tool may be used to clear the code from the TCM history. The TCM automatically clears the DTC from the TCM history if the vehicle completes 40 warm-up cycles without the DTC recurring.

### Diagnostic Aids

- Inspect the wiring for poor electrical connections at the TCM. Look for the following conditions:
  - A bent terminal.
  - A backed-out terminal.
  - A damaged terminal.
  - Poor terminal tension.
  - A chafed wire.
  - A broken wire inside the insulation.
- You may have to drive the vehicle in order to experience a fault.

## DIAGNOSTIC TROUBLE CODES (DTC)

### Test Description

The numbers below refer to the step numbers on the diagnostic table.

3. This step tests ignition voltage.
4. This step tests for current first range ratio.
5. This step tests speed sensor readings.
6. This step tests for clutch slippage in first range.
7. This step checks for evidence of clutch failure.

### DTC P0731 Incorrect 1st Gear Ratio

Step	Action	Value(s)	Yes	No
1	Was the <b>Beginning The Troubleshooting Process</b> (Paragraph 5–4A) performed?	—	<i>Go to Step 2</i>	<i>Go to Beginning The Troubleshooting Process (Paragraph 5–4A)</i>
2	Perform the A/T Fluid Checking Procedure (Appendix P) and correct the fluid level if necessary. Did you perform the procedure?	—	<i>Go to Step 3</i>	<i>Go to A/T Fluid Checking Procedure (Appendix P)</i>
3	1. Start the engine. 2. Record the DTC Failure Record data. 3. Using the Scan Tool, measure ignition voltage. Is voltage within the specified value?	9–18V (12V TCM); 18–32V (24V TCM)	<i>Go to Step 4</i>	<i>Resolve voltage problem (Refer to DTC P0562 and P0563)</i>
4	1. Install the Scan Tool. 2. Monitor the gear ratio. Is the correct first range ratio shown?	3.1 for 1000 3.51 for 2000/ 2400	<i>Go to Step 5</i>	<i>Go to Diagnostic Aids</i>
5	1. Turn the ignition ON and drive the vehicle under normal operating conditions. 2. Using the Scan Tool, monitor engine, turbine, and output speed readings. Is speed sensor data erratic or are signal dropouts detected?	—	<i>Go to the appropriate speed sensor DTC</i>	<i>Go to Step 6</i>

## DIAGNOSTIC TROUBLE CODES (DTC)

### DTC P0734 Incorrect 4th Gear Ratio *(cont'd)*

Step	Action	Value(s)	Yes	No
5	<p><b>WARNING:</b> To help avoid injury or property damage caused by sudden and unexpected vehicle movement, do not start a stationary stall test until you:</p> <ul style="list-style-type: none"> <li>• Put the transmission in N (Neutral)...and</li> <li>• Apply the parking brake and service brake...and</li> <li>• Chock the vehicle wheels and take any other steps necessary to prevent the vehicle from moving...and</li> </ul> <p>Warn personnel to keep clear of the vehicle and its path.</p> <p><b>CAUTION:</b> Do not perform a clutch test in fourth or fifth range under stall conditions (above 1400 rpm with brakes held), or possible clutch damage could occur.</p> <ol style="list-style-type: none"> <li>1. Using the Scan Tool, select clutch test mode.</li> <li>2. With brakes applied, move the selector lever to <b>D</b> (Drive).</li> <li>3. With engine at idle, select and attain the range indicated by the DTC. Turbine speed should go to zero.</li> <li>4. Monitor turbine speed while increasing engine speed to 1400 rpm.</li> </ol> <p>Did turbine speed remain at zero?</p>	—	Go to Diagnostic Aids	Go to Step 6
6	<p>Remove the dipstick and inspect the transmission fluid for clutch debris or burnt odor. If necessary, drain a small amount of fluid for this inspection.</p> <p>Are there signs of a clutch failure?</p>	—	Go to Step 7	Go to Step 8
7	<p>Remove the transmission for overhaul or replacement (refer to Mechanic's Tips).</p> <p>Is replacement complete?</p>	—	Go to Step 10	—
8	<p>Inspect the control valve body for stuck or sticking trimmer valves (refer to Mechanic's Tips).</p> <p>Was a valve problem found and repaired?</p>	—	Go to Step 10	Go to Step 9
9	<p>Replace B solenoid (refer to Mechanic's Tips).</p> <p>Is replacement complete?</p>	—	Go to Step 10	—
10	<p>In order to verify your repair:</p> <ol style="list-style-type: none"> <li>1. Clear the DTC.</li> <li>2. Operate the vehicle in all ranges under normal driving conditions.</li> </ol> <p>Did the DTC return?</p>	—	Begin the diagnosis again. Go to Step 1	System OK

## DIAGNOSTIC TROUBLE CODES (DTC)

### DTC P0741 Torque Converter Clutch System Stuck Off *(cont'd)*

Step	Action	Value(s)	Yes	No
3	<p>This condition indicates that the TCC is mechanically stuck OFF. Check for the following conditions:</p> <ul style="list-style-type: none"> <li>• Worn TCC clutch</li> <li>• Faulty solenoid F</li> <li>• Debris in the TCC valve bore (stuck valve)</li> <li>• Clogged or restricted converter relief passage</li> </ul> <p>Did you find and repair a problem?</p>	—	<i>Go to Step 4</i>	—
4	<p>In order to verify your repair:</p> <ol style="list-style-type: none"> <li>1. Clear the DTC.</li> <li>2. Drive the vehicle under conditions noted in failure records.</li> <li>3. Using the Scan Tool, monitor TCC slip speed. The TCC must engage/disengage when commanded.</li> <li>4. Use the Scan Tool, in the test passed section, to confirm the diagnostic test was run.</li> </ol> <p>Did the DTC return?</p>	—	<p><i>Begin the diagnosis again.</i></p> <p><i>Go to Step 1</i></p>	<i>System OK</i>

## DIAGNOSTIC TROUBLE CODES (DTC)

### Diagnostic Aids

- This DTC indicates the on-coming clutch being controlled by solenoid A is not applied or applied too slowly. This could indicate a leak or obstruction in a specific clutch apply circuit. Check the Scan Tool Failure Record data for previous or current range information when the DTC was set to determine the specific shift when the DTC was set. Refer to the Solenoid and Clutch Table (Appendix C) to determine which clutch circuit is suspect.
- If the condition is intermittent, connect the Scan Tool and select the speed sensor indicated by the code. If the signal is erratic, investigate and eliminate the following:
  - Intermittent wiring connection
  - Excessive vibration (driveline or engine torsionals)
  - Irregular sensor gap (loose sensor, loose tone wheel, or damaged tone wheel)
- Inspect and confirm that the OEM engine rating does not exceed the transmission model rating. Also inspect for the presence of an add-on engine power package or module. Whenever the engine horsepower or torque is increased over the transmission factory rating, a shift flare condition may occur leading to the diagnostic code indicated.

**NOTE: Clutch failure due to an OEM engine rating exceeding the Allison transmission rating, or the installation of a engine power package or module will not be covered under the Allison transmission warranty.**

### Test Description

The numbers below refer to the step numbers on the diagnostic table.

3. This step tests the ignition voltage.
4. This step tests for erratic speed sensor readings or signal dropout.
5. This step tests for internal hydraulic leakage.
6. This step tests for clutch capacity.

### DTC P0746 (Previously P1720) Solenoid A Controlled Clutch Stuck Off

Step	Action	Value(s)	Yes	No
1	Was the <b>Beginning The Troubleshooting Process</b> (Paragraph 5–4A) performed?	—	<i>Go to Step 2</i>	<i>Go to Beginning The Troubleshooting Process (Paragraph 5–4A)</i>
2	Perform the A/T Fluid Checking Procedure (Appendix P) and correct the fluid level if necessary. Did you perform the procedure?	—	<i>Go to Step 3</i>	<i>Go to A/T Fluid Checking Procedure (Appendix P)</i>
3	1. Install the Scan Tool. 2. Start the engine. 3. Record the DTC Failure Record data. 4. Use the Failure Record data to determine during which shift the code was set. 5. Using the Scan Tool, measure ignition voltage. Is voltage within the specified value?	9–18V (12V TCM); 18–32V (24V TCM)	<i>Go to Step 4</i>	<i>Resolve voltage problem (Refer to DTC P0562 and P0563)</i>
4	1. Turn the ignition ON and drive the vehicle under normal operating conditions. Make the shift determined in Step 3. 2. Using the Scan Tool, monitor turbine, engine, and output speed sensor readings. Is speed sensor data erratic or are dropouts in signal indicated?	—	<i>Go to the appropriate speed sensor DTC</i>	<i>Go to Step 5</i>

## DIAGNOSTIC TROUBLE CODES (DTC)

### DTC P0763 Shift Solenoid C Electrical

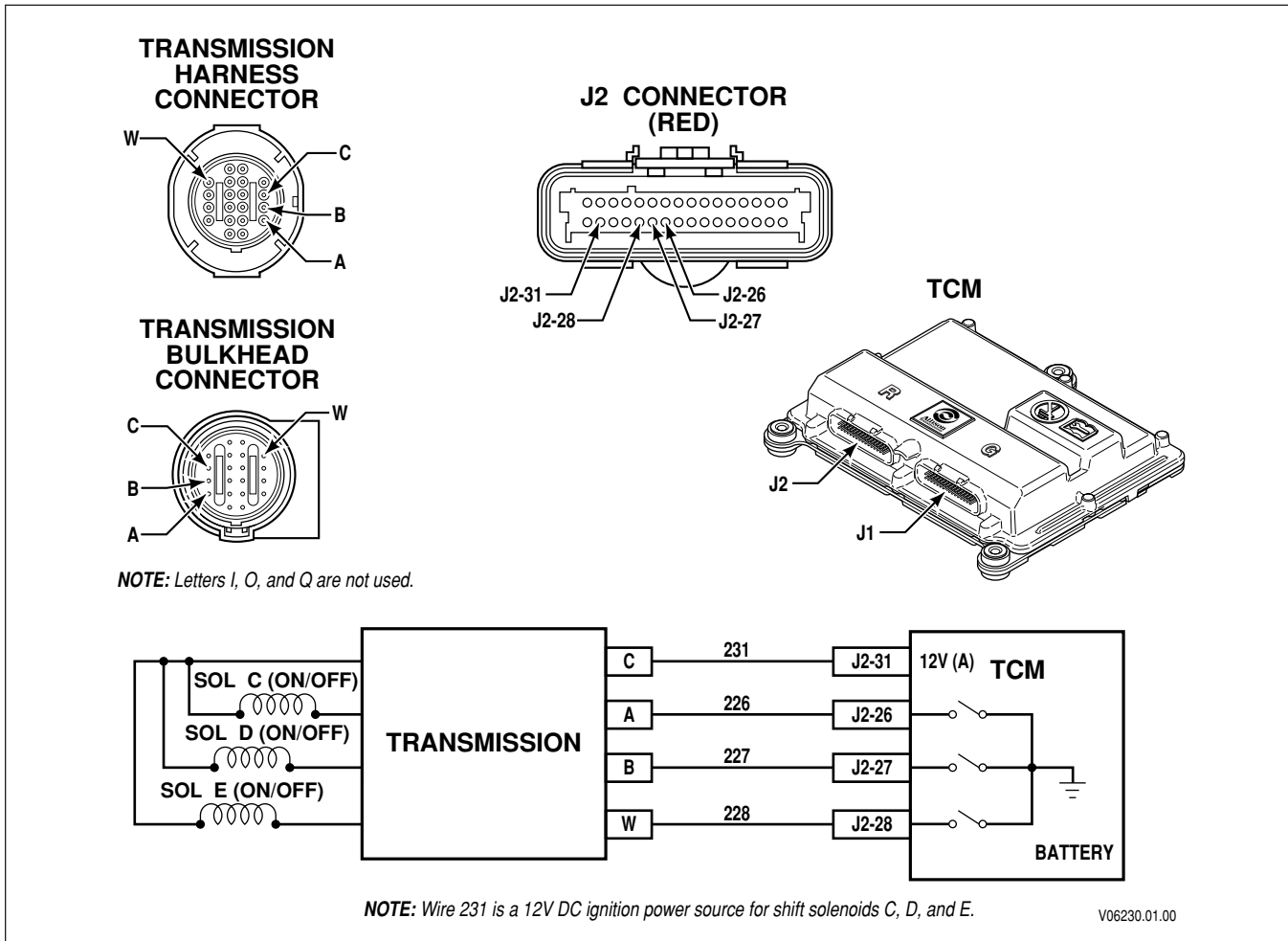

#### Circuit Description

Shift solenoid C is a normally closed (N/C) solenoid that provides control main pressure to stroke the C shift valve. The TCM determines the proper solenoid command logic to move the C shift valve to attain a particular range requested. A pressure switch, located at the end of the shift valve, sends shift valve position feedback to the TCM.

#### Conditions for Running the DTC

- The components are powered and ignition voltage is greater than 9V and less than 18V (12V TCM) or greater than 18V and less than 32V (24V TCM).
- TCM initialization is in process or engine speed is greater than 200 rpm and less than 7500 rpm for 5 seconds.

#### Conditions for Setting the DTC

DTC P0763 is set when the TCM detects one of the following conditions for more than 100 milliseconds:

- Open circuit or short to ground detected when C solenoid is commanded OFF.
- Short to power is detected when C solenoid is commanded ON.

## DIAGNOSTIC TROUBLE CODES (DTC)

### Action Taken When the DTC Sets

- When DTC P0773 is active, the following conditions will occur:
  - If the failure occurs while in a forward range, the transmission shifts to 1st, 3rd, or 5th range.
  - If the shift selector is moved to **N** (Neutral), the transmission will shift to neutral.
  - If the shift selector is moved to **R** (Reverse), the transmission shifts to neutral or reverse.
  - If the shift selector is moved to a forward range or reverse and transmission is compromised by overspeeding or direction change, transmission shifts to neutral.
  - If this failure is present at the solenoid electrical feed wire 231, the response is hydraulic default.
- DTC P0773 is stored in TCM history.
- The **CHECK TRANS** light illuminates on first occurrence.
- The TCM freezes shift adapts (DNA).
- The TCM inhibits TCC engagement.

### Conditions for Clearing the DTC/CHECK TRANS Light

A scan tool may be used to clear the code from the TCM history. The TCM automatically clears the DTC from the TCM history if the vehicle completes 40 warm-up cycles without the DTC recurring.

### Diagnostic Aids

- The diagnostic test performed to detect this DTC is very sensitive. Therefore, there is a high probability that an intermittent circuit condition may be causing this DTC to set. Make sure you check for the following conditions at the OEM harness first and then at the transmission internal harness.
- Inspect the wiring for poor electrical connections at the TCM. Look for the following conditions:
  - A bent terminal.
  - A backed-out terminal.
  - A damaged terminal.
  - Poor terminal tension.
  - A chafed wire.
  - A broken wire inside the insulation.
  - Inspect OEM wiring harness routing, looking for possible contact points where chafing could occur. Moving parts on the vehicle could be contacting the harness. Check for contact at the parking brake drum, suspension components, transmission shift linkage etc.
  - Inspect the internal transmission wiring harness for possible contact areas where chafing may occur.
- When diagnosing for an intermittent short or open, massage the wiring harness while watching the test equipment for a change. It may be necessary to check for shorting to ground at individual wires within a harness to isolate an intermittent condition. Refer to Section 4 — Wire Check Procedures.
- You may have to drive the vehicle in order to experience a fault. Use the data obtained from failure records to determine transmission range and/or certain vehicle operating variables such as temperature, run time, etc. This data can be useful in reproducing the failure mode where DTC was set.
- If the DTC appears to be temperature related, suspect a defective shift solenoid. It is possible for a shift solenoid to be temperature sensitive causing resistance values to fluctuate. This may cause an intermittent DTC to be set.
- If the circuit problem (open or short) is present at the 231 solenoid feed wire, other shift solenoid electrical DTCs may be present (C, D, E electrical codes).

## DIAGNOSTIC TROUBLE CODES (DTC)

### Conditions for Setting the DTC

DTC P0748 is set when one of the following conditions is detected for 125 milliseconds.

- Open circuit — TCM commanded duty cycle between 31 percent and 87 percent with no current present at trim solenoid A.
- Short to ground — TCM commanded duty cycle is over 87 percent with a current of less than 1.0 ampere at trim solenoid A.
- Short to power — TCM commanded duty cycle is under 15 percent with electrical current present.
- Whenever a P0748, P0778 combination is set in failure records, this is generally caused by having the transmission harness disconnected at the main transmission connector while the vehicle ignition is ON. Check the connection at the transmission and clear codes.

### Action Taken When the DTC Sets

- When DTC P0778 is active, the following conditions will occur:
  - If the failure occurs while in a forward range, the transmission will shift to 1st, 3rd, or 5th range.
  - If the shift selector is moved to **N** (Neutral), the transmission will shift to neutral.
  - If the shift selector is moved to **R** (Reverse), the transmission will shift to reverse.
  - If the shift selector is moved to a forward range or reverse and the transmission is compromised by over-speeding or a direction change, the transmission shifts to neutral.
- DTC P0778 is stored in the TCM history.
- The **CHECK TRANS** light illuminates.
- The TCM freezes shift adapts (DNA).

### Conditions for Clearing the DTC/CHECK TRANS Light

A Scan Tool may be used to clear the code from the TCM history. The TCM automatically clears the DTC from the TCM history if the vehicle completes 40 warm-up cycles without the DTC recurring.

### Diagnostic Aids

The diagnostic test performed to detect this DTC is very sensitive. Therefore, there is a high probability that an intermittent circuit condition may be causing this DTC to set. Check for the following conditions at the OEM harness first, then at the transmission internal harness.

- Inspect the wiring for poor electrical connections at the TCM connector and the main transmission connector. Look for the following conditions:
  - A bent terminal.
  - A backed-out terminal.
  - A damaged terminal.
  - Poor terminal tension.
  - A chafed wire.
  - A broken wire inside the insulation.
  - Inspect OEM wiring harness routing, looking for possible contact points where chafing could occur. Moving parts on the vehicle could be contacting the harness. Check for contact at the parking brake drum, suspension components, transmission shift linkage, etc.
  - Inspect the internal transmission wiring harness for possible contact areas where chafing may occur.
- When diagnosing for an intermittent short or open, massage the wiring harness while watching the test equipment for a change. It may be necessary to check for shorting to ground at individual wires within a harness to isolate an intermittent condition. Refer to Section 4 — Wire Check Procedures.

## DIAGNOSTIC TROUBLE CODES (DTC)

### Conditions for Setting the DTC

DTC P0841 is set when C solenoid is commanded ON and C pressure switch status remains OFF for a period of time. The time period is 5 seconds at 0°C (32°F) to -40°C (-40°F). The intent of this DTC is to detect a stuck shift valve, in the destroyed state, a mechanical solenoid failure, or an open circuit.

### Action Taken When the DTC Sets

- When DTC P0841 is active, the following conditions will occur:
  - If the failure occurs while in a forward range, the transmission shifts to 1st, 3rd or 5th range.
  - If the shift selector is moved to **N** (Neutral), the transmission will shift to neutral.
  - If the shift selector is moved to **R** (Reverse), the transmission shifts to reverse.
  - If the shift selector is moved to a forward range or reverse and the transmission is compromised by overspeeding or direction change, the transmission shifts to neutral.
- DTC P0841 is stored in TCM history.
- The **CHECK TRANS** light illuminates.
- The TCM inhibits TCC engagement.
- The TCM freezes shift adapts (DNA).

### Conditions for Clearing the DTC/CHECK TRANS Light

A Scan Tool may be used to clear the code from the TCM history. The TCM automatically clears the DTC from the TCM history if the vehicle completes 40 warm-up cycles without the DTC recurring.

### Diagnostic Aids

- Inspect the wiring for poor electrical connections at the TCM. Look for the following conditions:
  - A bent terminal.
  - A backed-out terminal.
  - A damaged terminal.
  - Poor terminal tension.
  - A chafed wire.
  - A broken wire inside the insulation.
- When a P0841 and P0843 are set in combination, this may indicate an open circuit condition is present at the pressure switch circuit or the shift valve is stuck in the destroyed state. See Section 4 — Beginning the Troubleshooting Process.
- When diagnosing for an intermittent short or open, massage the wiring harness while watching the test equipment for a change. It may be necessary to check for shorting to ground or opens at individual wires within a harness to isolate an intermittent condition. Refer to Section 4 — Wire Check Procedures and Appendix A, Section B.
- You may have to drive the vehicle in order to experience a fault. Use the data obtained from failure records to determine transmission range and/or certain vehicle operating variables such as temperature, run time, etc. This data can be useful in reproducing the failure mode where the DTC was set.
- Multiple inactive pressure switch DTCs may be due to a plugged Control Main Filter. Ensure that the initial 8000 km (5,000 mile) filter change was performed.

CLICK HERE TO **DOWNLOAD** THE COMPLETE MANUAL

- Thank you very much for reading the preview of the manual.
- You can download the complete manual from: [www.heydownloads.com](http://www.heydownloads.com) by clicking the link below



- Please note: If there is no response to CLICKING the link, please download this PDF first and then click on it.

CLICK HERE TO **DOWNLOAD** THE COMPLETE MANUAL

## DIAGNOSTIC TROUBLE CODES (DTC)

### Conditions for Setting the DTC

DTC P0843 sets during steady state operation when C shift valve is in the stroked state (commanded ON) and C pressure switch status is detected as destroyed (commanded OFF). Steady state is defined as attaining a valid range. The intent of this code is to detect an open condition in the pressure switch wiring circuit or the pressure switch.

Later software levels incorporate retry logic that allows the TCM to command C solenoid OFF and ON. If the pressure switch state does not change, and remains in the OFF state, DTCs P0841 and P0843 will set.

### Action Taken When the DTC Sets

- When DTC P0843 is active, the following conditions will occur:
  - If the failure occurs while in a forward range, the transmission shifts to another forward range.
  - If the shift selector is moved to **N** (Neutral), the transmission will shift to neutral.
  - If the shift selector is moved to **R** (Reverse), the transmission shifts to reverse.
  - If the shift selector is moved to a forward range or reverse and the transmission is compromised by overspeeding or direction change, the transmission shifts to neutral.
- DTC P0843 is stored in TCM history.
- The **CHECK TRANS** light illuminates.
- The TCM inhibits TCC engagement.
- The TCM freezes shift adapts (DNA).

### Conditions for Clearing the DTC/CHECK TRANS Light

A Scan Tool may be used to clear the code from the TCM history. The TCM automatically clears the DTC from the TCM history if the vehicle completes 40 warm-up cycles without the DTC recurring.

### Diagnostic Aids

- Inspect the wiring for poor electrical connections at the TCM. Look for the following conditions:
  - A bent terminal.
  - A backed-out terminal.
  - A damaged terminal.
  - Poor terminal tension.
  - A chafed wire.
  - A broken wire inside the insulation.
- When only a DTC P0843 is set, look for an intermittent open condition at the pressure switch circuit or an intermittent hydraulic failure (sticking valve). This code is set when the condition is present more than 3 times during a current drive cycle. See Appendix A, Section B — Finding an Intermittent Fault.
- When a P0843 and P0841 are set in combination, this may indicate an open circuit condition is present at the pressure switch circuit or the shift valve is stuck in the destroyed state. See Section 4 — Beginning the Troubleshooting Process.
- When diagnosing for an intermittent short or open, massage the wiring harness while watching the test equipment for a change. It may be necessary to check for an open condition at individual wires within a harness to isolate an intermittent condition. Refer to Section 4 — Wire Check Procedures and Appendix A, Section B.
- You may have to drive the vehicle in order to experience a fault. Use the data obtained from failure records to determine transmission range and/or certain vehicle operating variables such as temperature, run time, etc. This data can be useful in reproducing the failure mode where the DTC was set.
- Multiple inactive pressure switch DTCs may be due to a plugged Control Main Filter. Ensure that the initial 8000 km (5,000 mile) filter change was performed.

## DIAGNOSTIC TROUBLE CODES (DTC)

### Conditions for Setting the DTC

DTC P0846 sets when D solenoid is commanded ON and D pressure switch status remains OFF for a period of time. The time period is 5 seconds at 0°C (32°F) to –40°C (–40°F). The intent of this DTC is to detect a stuck shift valve, in the destroyed state, a mechanical solenoid failure, or an open circuit.

### Action Taken When the DTC Sets

- When DTC P0846 is active, the following conditions will occur:
  - If the failure occurs while in a forward range, the transmission shifts to another forward range.
  - If the shift selector is moved to **N** (Neutral), the transmission will shift to neutral.
  - If the shift selector is moved to **R** (Reverse), the transmission shifts to reverse.
  - If the shift selector is moved to a forward range or reverse and the transmission is compromised by overspeeding or direction change, the transmission shifts to neutral.
- DTC P0846 is stored in TCM history.
- The **CHECK TRANS** light illuminates.
- The TCM inhibits TCC engagement.
- The TCM freezes shift adapts (DNA).

### Conditions for Clearing the DTC/CHECK TRANS Light

A Scan Tool may be used to clear the code from the TCM history. The TCM automatically clears the DTC from the TCM history if the vehicle completes 40 warm-up cycles without the DTC recurring.

### Diagnostic Aids

- Inspect the wiring for poor electrical connections at the TCM. Look for the following conditions:
  - A bent terminal.
  - A backed-out terminal.
  - A damaged terminal.
  - Poor terminal tension.
  - A chafed wire.
  - A broken wire inside the insulation.
- When a P0846 and P0848 are set in combination, this may indicate an open circuit condition is present at the pressure switch circuit or the shift valve is stuck in the destroyed state. See Section 4 — Beginning the Troubleshooting Process.
- When diagnosing for an intermittent short or open, massage the wiring harness while watching the test equipment for a change. It may be necessary to check for an open condition at individual wires within a harness to isolate an intermittent condition. Refer to Section 4 — Wire Check Procedures and Appendix A, Section B.
- You may have to drive the vehicle in order to experience a fault. Use the data obtained from failure records to determine transmission range and/or certain vehicle operating variables such as temperature, run time, etc. This data can be useful in reproducing the failure mode when the DTC was set.
- Multiple inactive pressure switch DTCs may be due to a plugged Control Main Filter. Ensure that the initial 8000 km (5,000 mile) filter change was performed.

## DIAGNOSTIC TROUBLE CODES (DTC)

### Conditions for Setting the DTC

DTC P0848 sets during steady state operation when D shift valve is in the stroked state (commanded ON) and D pressure switch status is detected as destroked (commanded OFF). Steady state is defined as attaining a valid range. The intent of this code is to detect an open condition in the pressure switch wiring circuit or the pressure switch.

Later software levels incorporate retry logic that allows the TCM to command D solenoid OFF and ON. If the pressure switch state does not change, and remains in the OFF state, DTCs P0848 and P0846 will set.

### Action Taken When the DTC Sets

- When DTC P0848 is active, the following conditions will occur:
  - If the failure occurs while in a forward range, the transmission shifts to another forward range.
  - If the shift selector is moved to **N** (Neutral), the transmission will shift to neutral.
  - if the shift selector is moved to **R** (Reverse), the transmission shifts to reverse.
  - If the shift selector is moved to a forward range or reverse and the transmission is compromised by overspeeding or direction change, the transmission shifts to neutral.
- DTC P0848 is stored in TCM history.
- The **CHECK TRANS** light illuminates.
- The TCM inhibits TCC engagement.
- The TCM freezes shift adapts (DNA).

### Conditions for Clearing the DTC/CHECK TRANS Light

A Scan Tool may be used to clear the code from the TCM history. The TCM automatically clears the DTC from the TCM history if the vehicle completes 40 warm-up cycles without the DTC recurring.

### Diagnostic Aids

- Inspect the wiring for poor electrical connections at the TCM. Look for the following conditions:
  - A bent terminal.
  - A backed-out terminal.
  - A damaged terminal.
  - Poor terminal tension.
  - A chafed wire.
  - A broken wire inside the insulation.
- When only a DTC P0848 is set, look for an intermittent open condition at the pressure switch circuit or an intermittent hydraulic failure (sticking valve). This code is set when the condition is present more than 3 times during a current drive cycle. See Appendix A, Section B — Finding an Intermittent Fault.
- When a P0848 and P0846 are set in combination, this may indicate an open circuit condition is present at the pressure switch circuit or the shift valve is stuck in the destroked state. See Section 4 — Beginning the Troubleshooting Process.
- When diagnosing for an intermittent short or open, massage the wiring harness while watching the test equipment for a change. It may be necessary to check for an open condition at individual wires within a harness to isolate an intermittent condition. Refer to Section 4 — Wire Check Procedures and Appendix A, Section B.
- You may have to drive the vehicle in order to experience a fault. Use the data obtained from failure records to determine transmission range and/or certain vehicle operating variables such as temperature, run time, etc. This data can be useful in reproducing the failure mode when the DTC was set.
- Multiple inactive pressure switch DTCs may be due to a plugged Control Main Filter. Ensure that the initial 8000 km (5,000 mile) filter change was performed.

## DIAGNOSTIC TROUBLE CODES (DTC)

### Conditions for Setting the DTC

DTC P0871 sets when E solenoid is commanded ON and E pressure switch status remains OFF for a period of time. The time period is 5 seconds at 0°C (32°F) to -40°C (-40°F). The intent of this DTC is to detect a stuck shift valve, in the destroyed state, a mechanical solenoid failure, or an open circuit.

### Action Taken When the DTC Sets

- When DTC P0871 is active, the following conditions will occur:
  - If the failure occurs while in a forward range, the transmission shifts to another forward range.
  - If the shift selector is moved to **N** (Neutral), the transmission will shift to neutral.
  - if the shift selector is moved to **R** (Reverse), the transmission shifts to reverse.
  - If the shift selector is moved to a forward range or reverse and the transmission is compromised by overspeeding or direction change, the transmission shifts to neutral.
- DTC P0871 is stored in TCM history.
- The **CHECK TRANS** light illuminates.
- The TCM inhibits TCC engagement.
- The TCM freezes shift adapts (DNA).

### Conditions for Clearing the DTC/CHECK TRANS Light

A Scan Tool may be used to clear the code from the TCM history. The TCM automatically clears the DTC from the TCM history if the vehicle completes 40 warm-up cycles without the DTC recurring.

### Diagnostic Aids

- Inspect the wiring for poor electrical connections at the TCM. Look for the following conditions:
  - A bent terminal.
  - A backed-out terminal.
  - A damaged terminal.
  - Poor terminal tension.
  - A chafed wire.
  - A broken wire inside the insulation.
- When a P0871 and P0873 are set in combination, this may indicate an open circuit condition is present at the pressure switch circuit or the shift valve is stuck in the destroyed state. See Section 4 — Beginning the Troubleshooting Process.
- When diagnosing for an intermittent short or open, massage the wiring harness while watching the test equipment for a change. It may be necessary to check for an open condition at individual wires within a harness to isolate an intermittent condition. Refer to Section 4 — Wire Check Procedures and Appendix A, Section B.
- You may have to drive the vehicle in order to experience a fault. Use the data obtained from failure records to determine transmission range and/or certain vehicle operating variables such as temperature, run time, etc. This data can be useful in reproducing the failure mode when the DTC was set.
- Multiple inactive pressure switch DTCs may be due to a plugged Control Main Filter. Ensure that the initial 8000 km (5,000 mile) filter change was performed.

### Test Description

The numbers below refer to the step numbers on the diagnostic table.

2. This step tests for proper fluid level.
3. This step tests for proper main pressure.

## DIAGNOSTIC TROUBLE CODES (DTC)

### Conditions for Setting the DTC

DTC P0873 sets during steady state operation when E shift valve is in the stroked state (commanded ON) and E pressure switch status is detected as destroyed (commanded OFF). Steady state is defined as attaining a valid range. The intent of this code is to detect an open condition in the pressure switch wiring circuit or the pressure switch.

Later software levels incorporate retry logic that allows the TCM to command E solenoid OFF and ON. If the pressure switch state does not change, and remains in the OFF state, DTCs P0873 and P0871 will set.

### Action Taken When the DTC Sets

- When DTC P0873 is active, the following conditions will occur:
  - If the failure occurs while in a forward range, the transmission shifts to another forward range.
  - If the shift selector is moved to **N** (Neutral), the transmission will shift to neutral.
  - If the shift selector is moved to **R** (Reverse), the transmission shifts to reverse.
  - If the shift selector is moved to a forward range or reverse and the transmission is compromised by overspeeding or direction change, the transmission shifts to neutral.
- DTC P0873 is stored in TCM history.
- The **CHECK TRANS** light illuminates.
- The TCM inhibits TCC engagement.
- The TCM freezes shift adapts (DNA).

### Conditions for Clearing the DTC/CHECK TRANS Light

A Scan Tool may be used to clear the code from the TCM history. The TCM automatically clears the DTC from the TCM history if the vehicle completes 40 warm-up cycles without the DTC recurring.

### Diagnostic Aids

- Inspect the wiring for poor electrical connections at the TCM. Look for the following conditions:
  - A bent terminal.
  - A backed-out terminal.
  - A damaged terminal.
  - Poor terminal tension.
  - A chafed wire.
  - A broken wire inside the insulation.
- When only a DTC P0873 is set, look for an intermittent open condition at the pressure switch circuit or an intermittent hydraulic failure (sticking valve). This code is set when the condition is present more than 3 times during a current drive cycle. See Appendix A, Section B — Finding an Intermittent Fault.
- When a P0873 and P0871 are set in combination, this may indicate an open circuit condition is present at the pressure switch circuit or the shift valve is stuck in the destroyed state. See Section 4 — Beginning the Troubleshooting Process.
- When diagnosing for an intermittent short or open, massage the wiring harness while watching the test equipment for a change. It may be necessary to check for an open condition at individual wires within a harness to isolate an intermittent condition. Refer to Section 4 — Wire Check Procedures and Appendix A, Section B.
- You may have to drive the vehicle in order to experience a fault. Use the data obtained from failure records to determine transmission range and/or certain vehicle operating variables such as temperature, run time, etc. This data can be useful in reproducing the failure mode when the DTC was set.
- Multiple inactive pressure switch DTCs may be due to a plugged Control Main Filter. Ensure that the initial 8000 km (5,000 mile) filter change was performed.

## DIAGNOSTIC TROUBLE CODES (DTC)

### Conditions for Setting the DTC

DTC P0876 sets in two cases:

- When PRNDL and reverse pressure switch do not agree. When reverse range is selected and the reverse pressure switch is detected in the mechanically open/electrically OFF state for more than 1 second.
- When engine shutdown and reverse pressure switch do not agree. When engine shutdown is in process and the reverse pressure switch is detected in an improper state, mechanically open/electrically OFF, for more than a period of time that is temperature dependent. The time period is 5 seconds at 35°C (95°F) to 30 seconds at -20°C (-4°F).

### Action Taken When the DTC Sets

- When DTC P0876 is active, the following conditions will occur:
  - Calibration Dependent — The transmission will either lock-to-neutral or shift to 3rd or 5th range.
  - If the shift selector is moved to **N** (Neutral), the transmission will shift to neutral.
  - if the shift selector is moved to **R** (Reverse), the transmission shifts to reverse.
  - If the shift selector is moved to a forward range or reverse and the transmission is compromised by overspeeding or direction change, the transmission shifts to neutral. If an output speed fault or NSBU fault is present when this test fails, then hydraulic default is implemented.
- DTC P0876 is stored in TCM history.
- The **CHECK TRANS** light illuminates on the second occurrence.
- The TCM freezes shift adapts (DNA).
- The TCM inhibits TCC engagement

### Conditions for Clearing the DTC/CHECK TRANS Light

A Scan Tool may be used to clear the code from the TCM history. The TCM automatically clears the DTC from the TCM history if the vehicle completes 40 warm-up cycles without the DTC recurring.

### Diagnostic Aids

- Inspect the wiring for poor electrical connections at the TCM. Look for the following conditions:
  - A bent terminal.
  - A backed-out terminal.
  - A damaged terminal.
  - Poor terminal tension.
  - A chafed wire.
  - A broken wire inside the insulation.
- When diagnosing for an intermittent short or open, massage the wiring harness while watching the test equipment for a change. It may be necessary to check for shorting to ground at individual wires within a harness to isolate an intermittent condition. Refer to Section 4 — Wire Check Procedures and Appendix A, Section B.
- You may have to drive the vehicle in order to experience a fault. Use the data obtained from failure records to determine transmission range and/or certain vehicle operating variables such as temperature, run time, etc. This data can be useful in reproducing the failure mode when the DTC was set.
- Multiple inactive pressure switch DTCs may be due to a plugged Control Main Filter. Ensure that the initial 8000 km (5,000 mile) filter change was performed. To help reduce multiple pressure switch DTCs from setting due to a plugged control main filter or slow pump prime, later software levels have a time delay up to 30 seconds before a pressure switch test is enabled.

## DIAGNOSTIC TROUBLE CODES (DTC)

### Diagnostic Aids

An Intermittent condition may be the cause of the problem. Return the vehicle to the OEM for further troubleshooting.

### DTC P1779 Engine Torque Delivered To TCM Signal

Step	Action	Yes	No
1	Was the <b>Beginning The Troubleshooting Process</b> (Paragraph 5–4A) performed?	<i>Go to Step 2</i>	<i>Go to Beginning The Troubleshooting Process (Paragraph 5–4A)</i>
2	1. Install the Scan Tool. 2. Start the engine. 3. Record DTC failure records. 4. Clear the DTC and drive the vehicle. Attempt to duplicate the same operating conditions observed in failure records.  <b>NOTE: This DTC indicates that the managed engine torque signal sent from the engine PCM to the transmission TCM is either under or over a set percentage value for a set period of time.</b> Did DTC P1779 return?	<i>Go to Step 3</i>	<i>Go to Diagnostic Aids</i>
3	Inspect the routing of wire 109 (GM wire circuit 2467) between the TCM and PCM. Was chafing or wire damage found?	<i>Go to Step 4</i>	<i>Go to Step 5</i>
4	<b>NOTE: The vehicle OEM has responsibility for all external wiring harness repair. Harness repairs performed by Allison Transmission distributors and dealers are not covered by Allison Transmission warranty.</b> Repair or replace the vehicle wiring harness. Is the repair complete?	<i>Go to Step 6</i>	—
5	Return the vehicle to the OEM to troubleshoot for cause of low or high torque signal. Below are some possible causes for this DTC. <ul style="list-style-type: none"> <li>• Defective engine PCM.</li> <li>• Circuit fault at wire 116.</li> <li>• Improper calibration for engine PCM.</li> </ul> Was problem found and repaired?	<i>Go to Step 6</i>	—
6	In order to verify your repair: <ol style="list-style-type: none"> <li>1. Clear the DTC.</li> <li>2. Drive the vehicle under conditions noted in failure records.</li> <li>3. Use the Scan Tool, in the test passed section, to confirm the diagnostic test was run.</li> </ol> Did the DTC return?	<i>Begin the diagnosis again.</i> <i>Go to Step 1</i>	<i>System OK</i>

## DIAGNOSTIC TROUBLE CODES (DTC)

### DTC P2771 Four-Wheel Drive Switch Circuit *(cont'd)*

Step	Action	Value(s)	Yes	No
16	<p>In order to verify your repair:</p> <ol style="list-style-type: none"> <li>1. Clear the DTC.</li> <li>2. Drive the vehicle under normal operating conditions.</li> <li>3. Using the Scan Tool, monitor the 4WD low status. The 4WD low status must indicate NO when 4WDHI is selected, and YES when 4WDLO is selected.</li> </ol> <p>Did the DTC return?</p>	—	<p><i>Begin the diagnosis again. Go to Step 1.</i></p>	<p><i>System OK</i></p>

## DIAGNOSTIC TROUBLE CODES (DTC)

### DTC U0031 (Previously U1300) J1850 (Class 2) Serial Data Communication Link Low

Step	Action	Yes	No
4	<p><b>NOTE: The vehicle OEM has responsibility for all external wiring harness repair. Harness repairs performed by Allison Transmission distributors and dealers are not covered by Allison Transmission warranty.</b></p> <p>Repair the vehicle wiring harness. Is the repair complete?</p>	Go to Step 6	—
5	<p>Switch the current TCM with a known good unit. Check for proper communication. If this repairs the condition, reinstall the “defective” TCM to verify the TCM failure and then install a new TCM. Is replacement complete?</p>	Go to Step 6	—
6	<p>In order to verify your repair: 1. Connect the Scan Tool. 2. Clear the DTC. Did the DTC return?</p>	<p>Begin the diagnosis again. Go to Step 1</p>	System OK

## DIAGNOSTIC TROUBLE CODES (DTC)

### DTC U1000–U1096 Class 2 Controller State of Health Failure

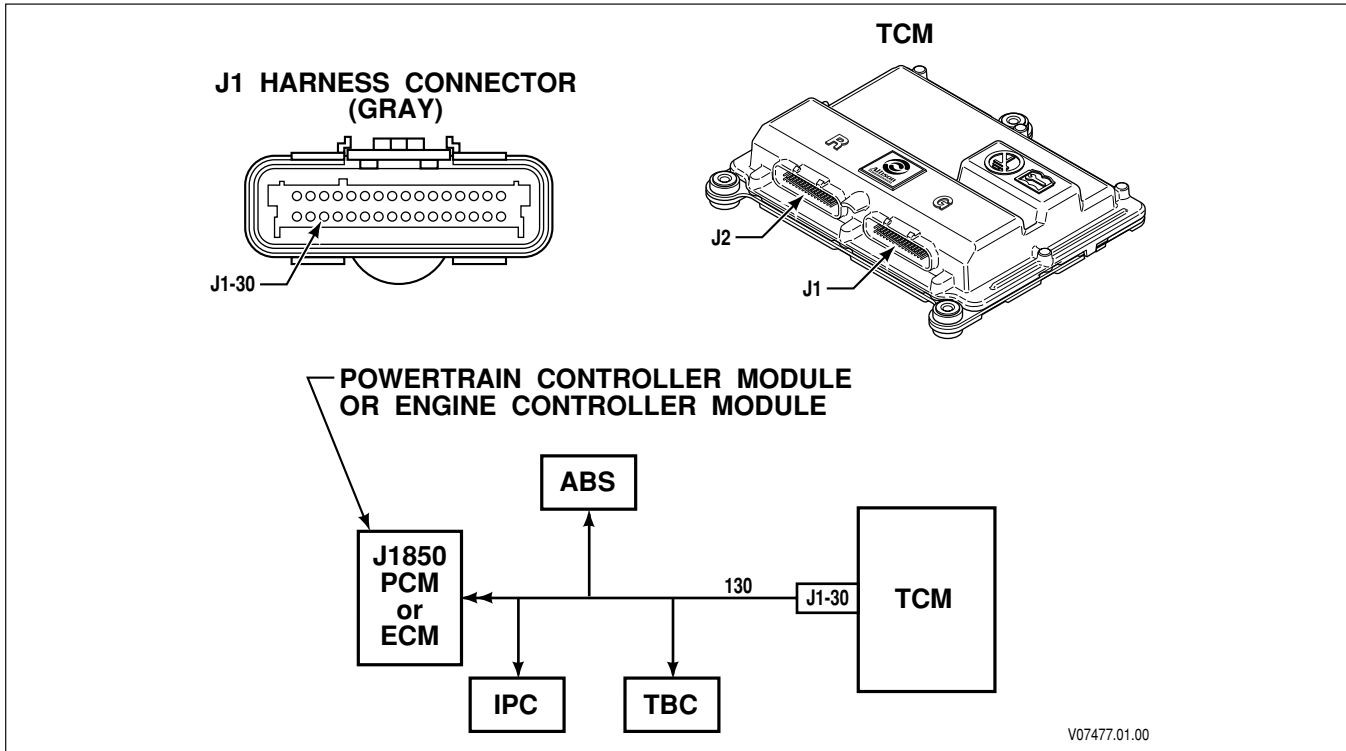

#### Circuit Description

Applications that employ J1850 class 2 serial communication use wire 130 to send operational information and commands among the various control modules. The control modules included are the Powertrain Control Module (PCM), Antilock Brake System Controller (ABS), Truck Body Controller (TBC) and Instrument Panel Cluster (IPC). Each controller sends out a state of health (SOH) message approximately once every second. The TCM uses these SOH messages to monitor the condition of the devices on the class 2 serial link.

The following DTCs identify the specific controller noted:

DTC Number	Control Module
U1000	Class II–Loss of Serial Data Communication
U1016	Powertrain Control Module (PCM)
U1041	Antilock Brake System Module (ABS)
U1064	Truck Body Controller Module (TBC)
U1096	Instrument Panel Cluster Module (IPC)

#### Conditions for Running the DTC

The components are powered and ignition voltage is greater than 9V and less than 18V (12V TCM) or greater than 18V and less than 32V (24V TCM).

## GENERAL TROUBLESHOOTING OF PERFORMANCE COMPLAINTS

Table 7–1. Troubleshooting Performance Complaints (*cont'd*)

Problem	Possible Cause	Suggested Remedy
EXCESSIVE FLARE — ENGINE OVERSPEED ON FULL- THROTTLE UPSHIFTS ( <i>cont'd</i> )	Leaking trim solenoids*	Repair or replace trim solenoids (refer to Service Manual)
	G solenoid mechanical failure	Repair or replace trim solenoids (refer to Service Manual)
	Erratic speed sensor signal	See speed sensor DTCs
	Leaking piston seals or slipping clutch plates in range involved*	Overhaul transmission (refer to transmission Service Manual)
SHUDDER WHEN SHIFTING INTO FORWARD OR REVERSE RANGE	Intermittent short to ground at F (TCC) solenoid circuit (wire 229). Could be accompanied by a P0743—F solenoid electrical DTC. It is possible to have this complaint without a DTC setting on earlier software.* This complaint is worse with pre-N04 software levels due to the different hydraulic schedule. Reverse range is not fully attainable due to TCC valve application blocking C5 feed circuit. This causes the range inhibit light to illuminate.	Repair or replace wire 229
	Low main pressure*	See Low Pressure Section
	Faulty trim solenoid*	Replace solenoid (refer to Service Manual or Mechanic's Tips)
	Sticky trim valve*	Rebuild control valve assembly (refer to Service Manual or Mechanic's Tips)
	C–1 or C-3 clutch failure*	Repair transmission (refer to Service Manual)
ABNORMAL STALL SPEEDS (Stall In First Range — Fifth Range)		
A. High Stall Speeds	Not in gear	Select <b>D</b> (Drive)
	Low fluid level, aerated fluid*	Add fluid to correct level (refer to Mechanic's Tips for proper dipstick calibration)
	Faulty torque converter	Replace torque converter
	Incorrect torque converter	Replace torque converter (refer to transmission Service Manual)
	Clutch pressure low*	See Low Pressure Section and Appendix B

\* See Inhibit Section 2–5

## APPENDIX A—DIAGNOSING INTERMITTENT DTCs

### C. Recurring Conditions

A recurring condition might be:

- Rain
- Outside temperature above or below a certain temperature
- Only on right-hand or left-hand turns
- When the vehicle hits a bump, etc.

If such a condition can be related to the DTC, it is easier to find the cause. If the time between DTC occurrences is very short, troubleshooting is easier than if it is several weeks or more between DTC occurrences.

- Repair parts for the internal wiring harness will be available through the Allison Transmission Parts Distribution Center (PDC). Use the P/N from your appropriate parts catalog or from Appendix E in this manual. Allison Transmission is responsible for warranty on these parts.
- Repair parts for the external harnesses and external harness components must be obtained through the vehicle OEM and the OEM is responsible for warranty on these parts.

APPENDIX D—WIRE/CONNECTOR TABLES

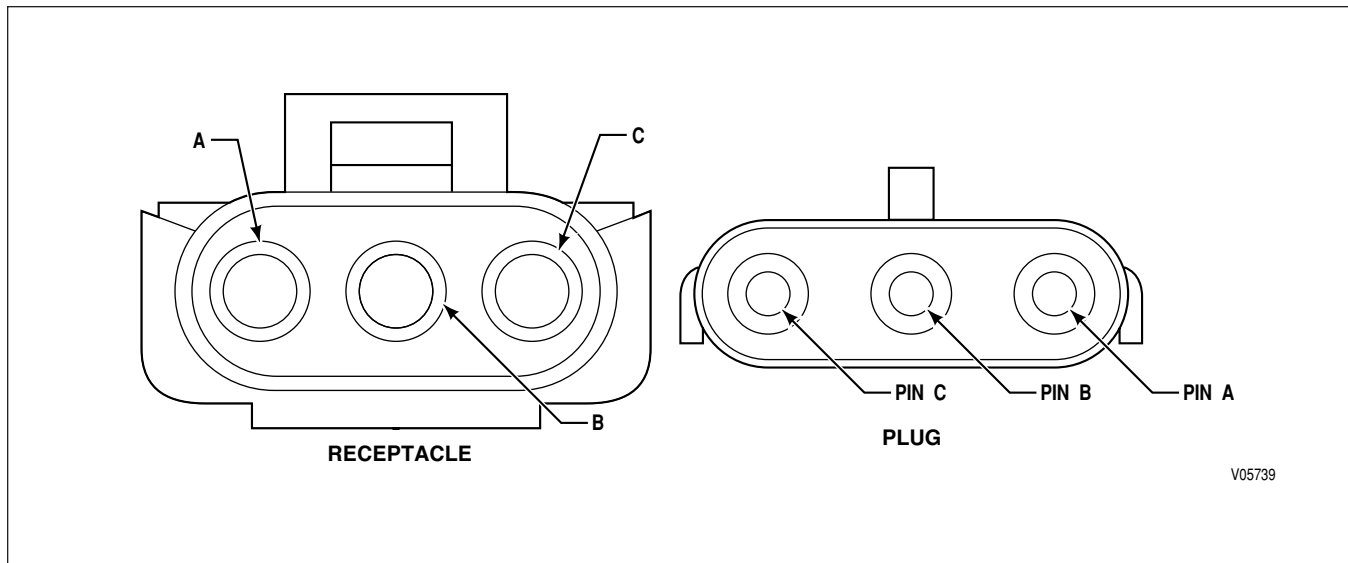
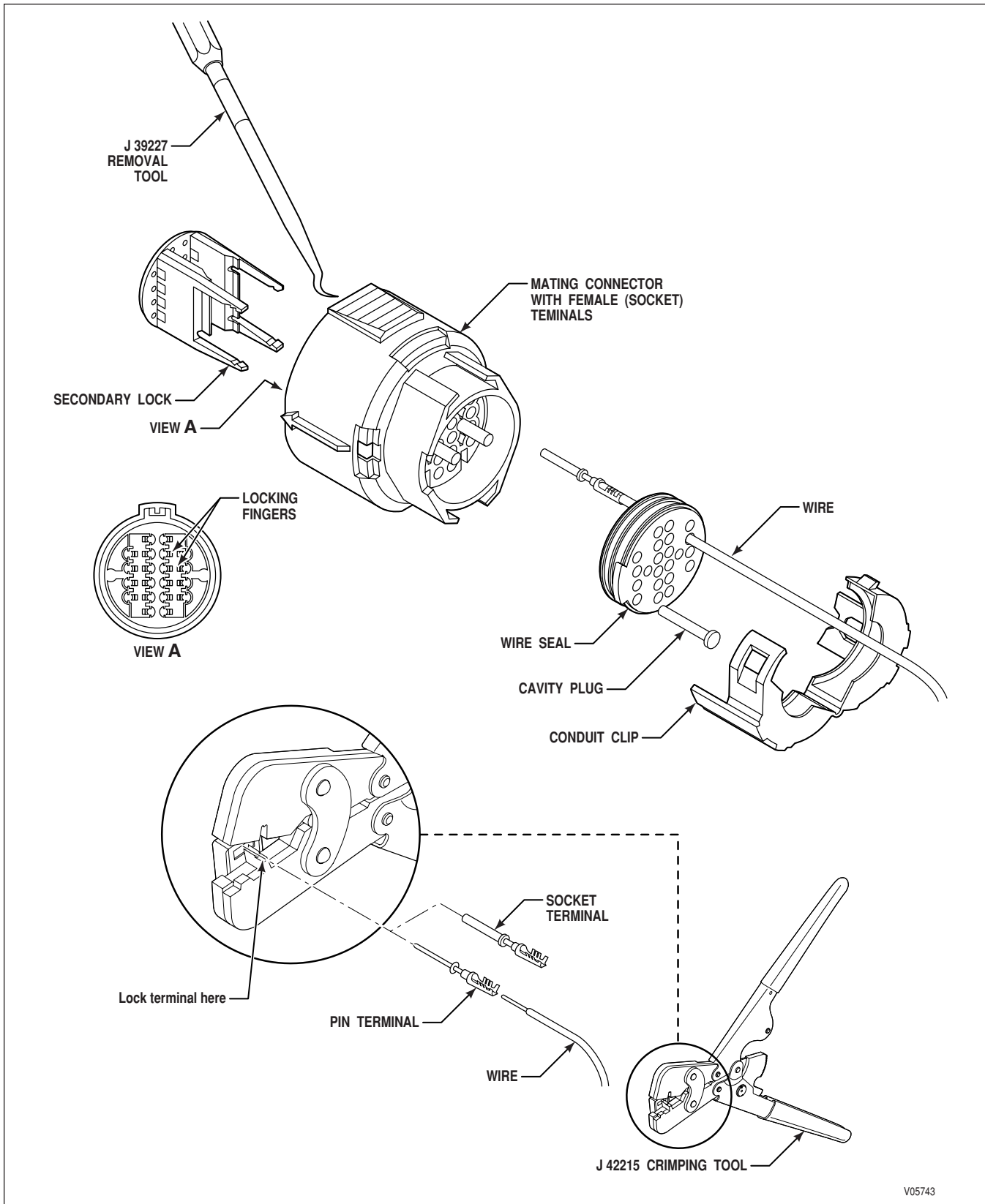

Figure D-5. TPS Connector

THROTTLE POSITION SENSOR CONNECTOR

Terminal No.	Color	Wire No.	Description	Termination Point(s)
A	Green	220	Analog Ground	TCM J2-20
B	Blue	209	TPS Signal	TCM J2-9
C	Pink	219	TPS Hi	TCM J2-19

APPENDIX E—CONNECTOR REPAIR INFORMATION



V05743

Figure E-1B. Delphi-Packard Micro Pack Connector (Main Transmission Connector)

**APPENDIX E—CONNECTOR REPAIR INFORMATION****C. Terminal Crimping** (*cont'd*)

5. Be sure the lock tang is lifted to allow proper reseating of the terminal.
6. Push on the wire until the terminal is completely into the cavity. (A click will be heard and the terminal should stay in place when the wire is lightly pulled.)

**D. Terminal Crimping Using Alternate Tool J 35123**

1. Insert the remover tool in the front side of the connector to release the locktab, and pull the terminal out the rear of the connector. Pull the terminal and wire out the rear of the connector to complete Steps (3) through (7).
2. Push open the terminal holder on the crimper tool J 35123 and insert a terminal into the opening marked 18–16 (Figure E–3, View C) so that the crimp ends point up. Release the terminal holder.
3. Slightly close the crimping tool (close until one click is heard) but do not start to crimp the terminal. Place the terminal on the wire so it is in the same position as it will be when pulled back into the connector. The terminal should be positioned so that the lock tang is on the side of the cavity which has the notch in the middle (for the remover tool).
4. Insert the wire into the terminal until the wire contacts the holder. (By doing this, the core and insulation should be properly positioned for the core and insulation crimp wings.)
5. Squeeze the crimper fully until it opens when released.
6. Open the terminal holder and remove the wire and terminal from the crimping tool.
7. Pull on the terminal to assure a tight crimp.
8. Be sure the lock tang is lifted to allow proper reseating of the terminal.
9. Push on the wire until the terminal is completely into the cavity. (A click will be heard and the terminal should stay in place if the wire is lightly pulled.)

## APPENDIX E—CONNECTOR REPAIR INFORMATION

### **C. Terminal Crimping** (*Figure E-6, View B*) (*cont'd*)

5. Squeeze the crimping tool handle until it releases. The terminal is now crimped onto the wire.
6. Remove the terminal and wire from the crimping tool.
7. Tug on the terminal to be sure the crimp is tight.
8. Install a 25 mm (one inch) long piece of heat shrink tubing over the wire insulation just behind the terminal. Apply heat to shrink and lock the tubing to the insulation.

### **D. Terminal Insertion (all connectors except ECD bulkhead)**

1. Insert the terminal and attached wire through the proper hole in the grommet.
2. Push on the terminal and wire until the terminal clicks into position. Pull gently on the wire to be sure that the terminal is fully seated.

## APPENDIX E—CONNECTOR REPAIR INFORMATION

### NOTES

APPENDIX H—HYDRAULIC SCHEMATICS

HYDRAULIC SCHEMATIC – 1st RANGE  
1000 AND 2000 PRODUCT FAMILIES

G Solenoid Added—3rd Quarter 2003

G Solenoid Lowers Main Pressure  
And Increases Cooler Flow  
When Energized (Typically at  
Low Throttle, Low Speed)

(Shown Energized)

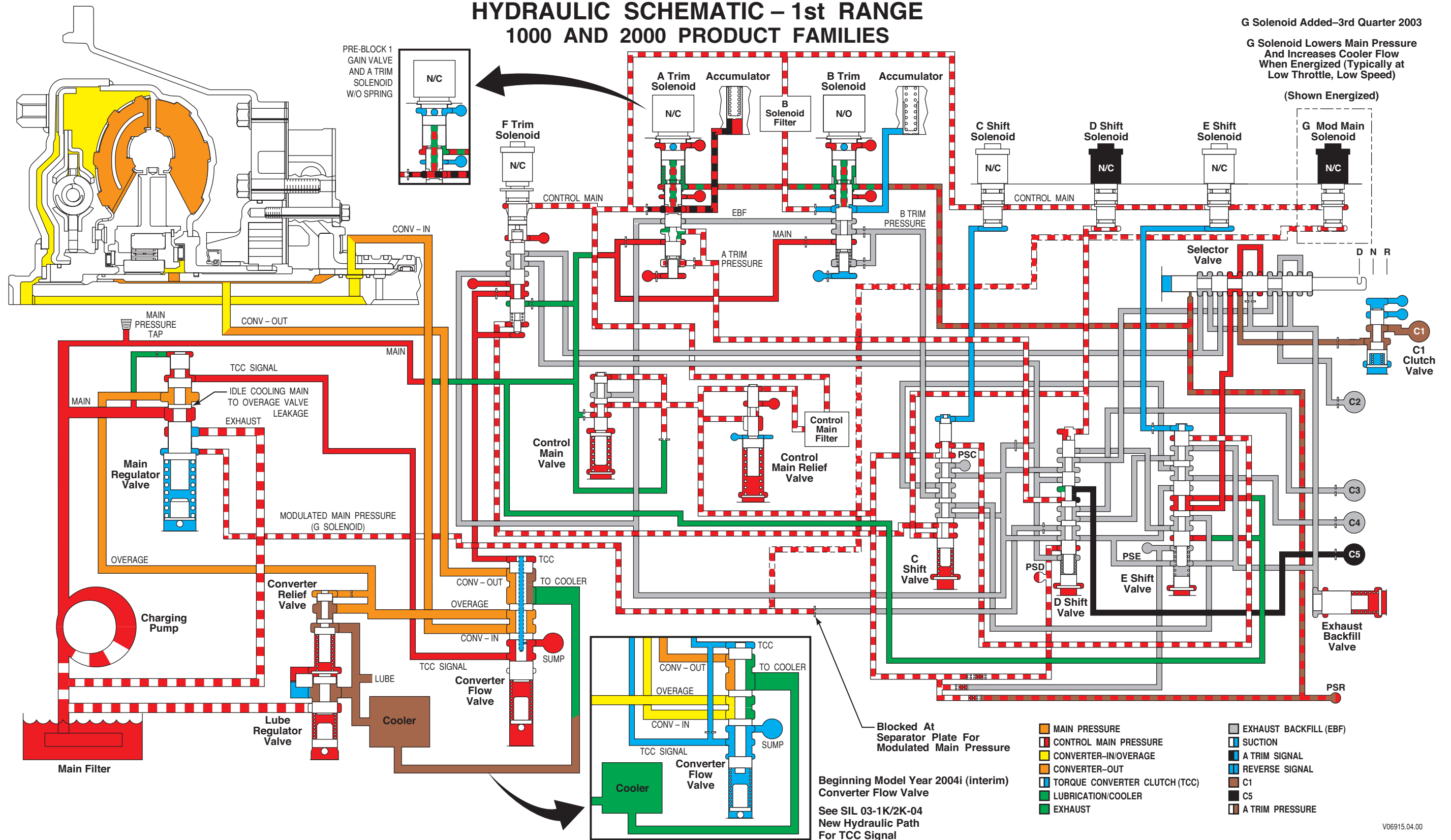

Figure H-4. Hydraulic Schematic — 1st Range

APPENDIX K—RESISTANCE VS. TEMPERATURE

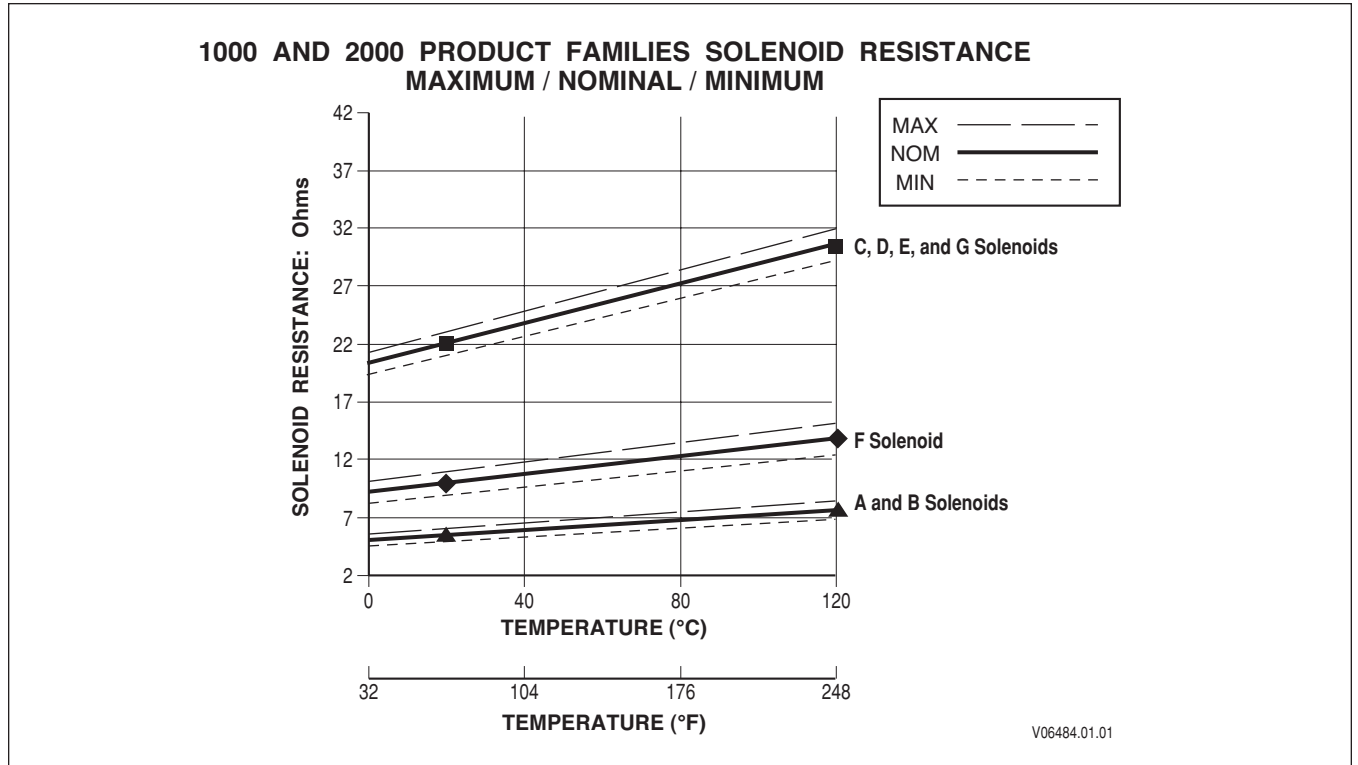

Figure K-1. Solenoid Resistance vs. Temperature Graph

Table K-1. Solenoid Resistance vs. Temperature

Sump Temperature		Solenoid A, B Resistance	Solenoid C, D, E, G Resistance	Solenoid F Resistance
(°C)	(°F)	(Ω)	(Ω)	(Ω)
0	32	4.5	20.0	9.5
20	68	5.5	22.0	10.5
40	104	6.5	24.5	11.5
80	176	7.5	27.0	12.5
120	248	8.5	29.5	13.5

## APPENDIX N—INPUT/OUTPUT FUNCTIONS

### WARNING!

This schematic shows the intended use of the specified controls feature which has been validated in the configuration shown. Any miswiring or use of this feature which differs from that shown could result in damage to equipment or property, personal injury, or loss of life. ALLISON TRANSMISSION IS NOT LIABLE FOR THE CONSEQUENCES ASSOCIATED WITH MISWIRING OR UNINTENDED USE OF THESE FEATURES.

### E. AUXILIARY FUNCTION RANGE INHIBIT

**USES:** Prevents inadvertent range selection when auxiliary equipment (e.g. wheelchair lift) is operating. May also be used to prevent neutral-to-range shifts unless the brake pedal is depressed.

**VARIABLES TO SPECIFY:** None

**VOCATIONS:** Various. Not for use in emergency equipment.

Typical Uses: School bus — brake pedal input  
 Special service bus— wheelchair lift interlock  
 Motorhome — “Door Ajar” interlock

### WARNING!

If this function is enabled in the shift calibration, the function **MUST** be integrated into the vehicle wiring. If the function is available in the shift calibration but will not be used in the vehicle, it **MUST** be disabled in the calibration.

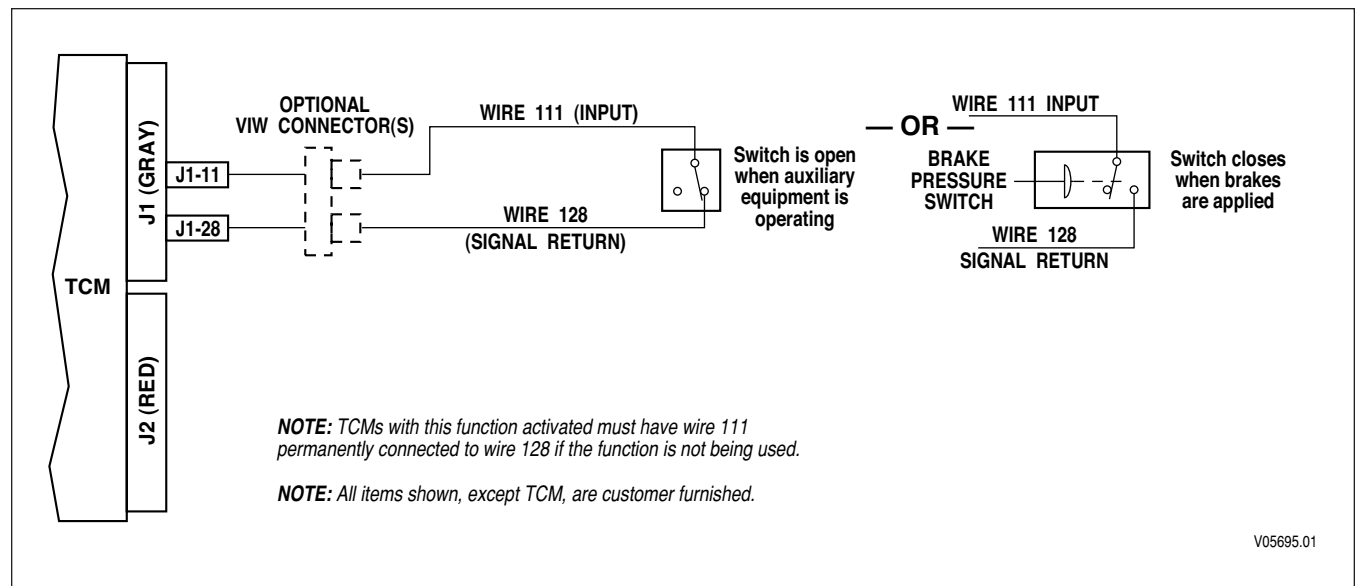

Figure N-3. Auxiliary Function Range Inhibit

CLICK HERE TO **DOWNLOAD** THE COMPLETE MANUAL

- Thank you very much for reading the preview of the manual.
- You can download the complete manual from: [www.heydownloads.com](http://www.heydownloads.com) by clicking the link below



- Please note: If there is no response to CLICKING the link, please download this PDF first and then click on it.

CLICK HERE TO **DOWNLOAD** THE COMPLETE MANUAL