

FR15

Service manual

Transmission

Form 604.06.415

CLICK HERE TO **DOWNLOAD** THE COMPLETE MANUAL

- Thank you very much for reading the preview of the manual.
- You can download the complete manual from: www.heydownloads.com by clicking the link below



- Please note: If there is no response to CLICKING the link, please download this PDF first and then click on it.

CLICK HERE TO **DOWNLOAD** THE COMPLETE MANUAL

Example:

Dimension A	5.40 mm
- Dimension B	<u>3.20 mm</u>

gives 2.20 mm

Correct clearance 2.00 - 2.90 mm.

Carry out any correction by installation of one compensating plate (= inner plate) of corresponding thickness.

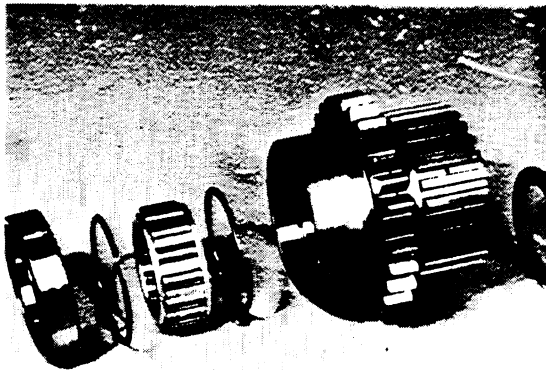

48/1

Install components of spur gear K1 according to the illustration.

NOTE: large contact area of the angle rings showing to the roller cage.

Install components with grease.

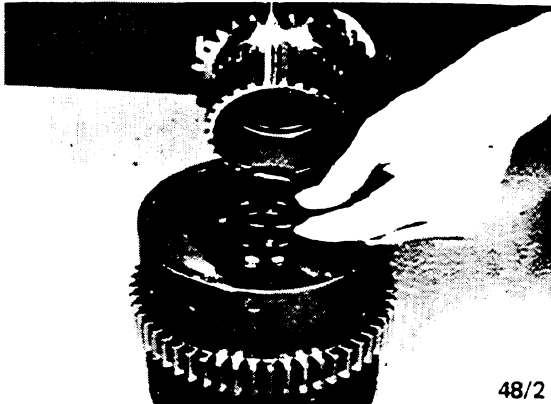

48/2

Replace thrust plate and assemble spur gear.

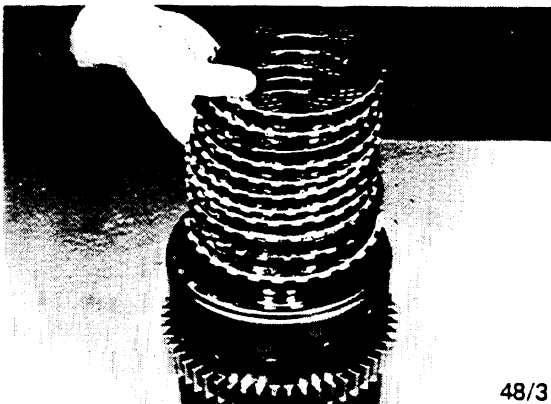

48/3

Assemble plate pack KV (long hub side of piston carrier) as follows:

Insert 1st outer plate $s = 2.40 \text{ mm}$ (*) and lay inner plate $s = 2.50 \text{ mm}$ upon it.

Insert alternating the remaining outer plates (8 pieces) and inner plates (7 pieces) - see also Section 1 "Clutch Assembly Specifications"-page 12.

Install subsequently backing plate and fix plate pack with circlip.

Measure plate play "nominal value 2.00 - 2.90 mm".

(*) 1st outer plate post modification $s = 2.00 \text{ mm}$.

Study SAFETY RULES in the front of this manual thoroughly for the protection of machine and safety of personnel.

	V				R			N		
	1	2	3	4	1	2	3=4	1	2	3=4
M 1				•	○	○	•			
M 2	•				•					•
M 3	○	○	•		○	○	•			
M 4	•	•			•	•			•	•

V = Forward direction;
R = Reverse direction;
N = Neutral.

White points indicate the transmission disengagement consequent to actuation of left brake pedal and parking brake. In this condition, solenoid valves M₁ and M₃ selecting the direction are de-energized.

The transmission disengagement is limited to low ranges (1st and 2nd).

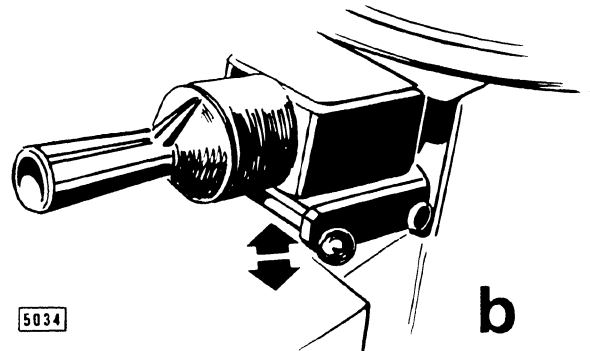
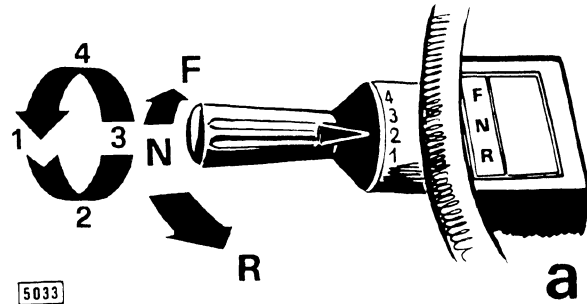

Transmission shift lever (a) and transmission shift lock lever (b).

- F = forward
- N = neutral
- R = reverse

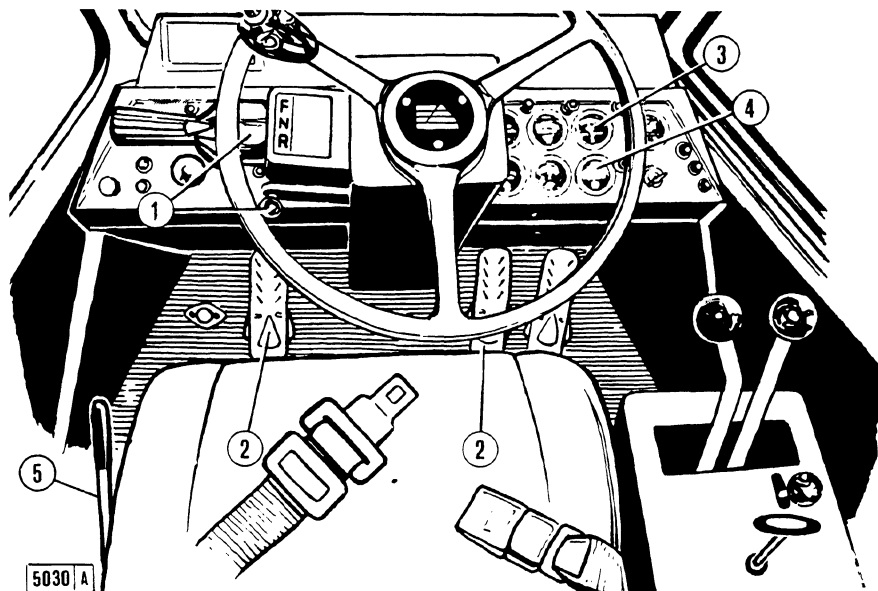



Operating controls and instruments

1. Transmission shift lever - 2. Brake pedals (the right brake pedal does not actuate the transmission neutralizer) - 3. Transmission pressure gauge - 4. Transmission oil temperature gauge - 5. Parking brake (brake on transmission output shaft is actuated while transmission is disengaged).

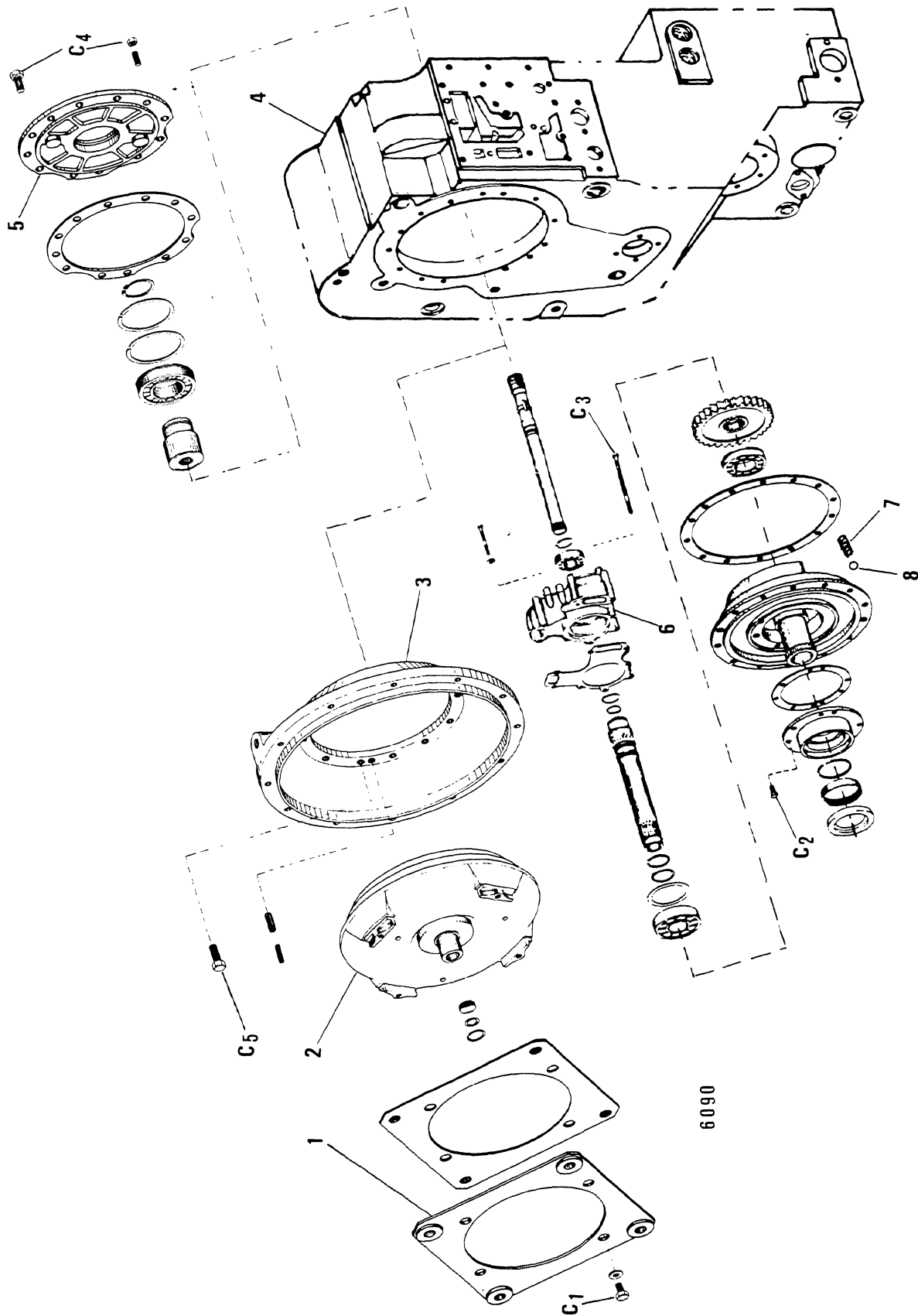
Study SAFETY RULES in the front of this manual thoroughly for the protection of machine and safety of personnel.

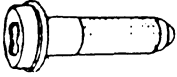
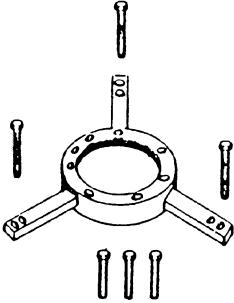
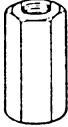
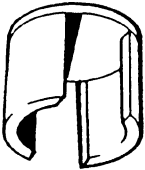

6090

	<p>Driver to secure safety plate of output flange</p>	<p>75297594</p>
	<p>Puller for oil pump</p>	<p>75297584</p>
	<p>Positioning device for transmission shafts</p>	<p>75297583</p>
	<p>Spring compression tool for clutch packs (to be used with vertical press)</p>	<p>75297569</p>
	<p>Alignement tool for clutch packs</p>	<p>75297585</p>

Study SAFETY RULES in the front of this manual thoroughly for the protection of machine and safety of personnel.

CLICK HERE TO **DOWNLOAD** THE COMPLETE MANUAL

- Thank you very much for reading the preview of the manual.
- You can download the complete manual from: www.heydownloads.com by clicking the link below



- Please note: If there is no response to CLICKING the link, please download this PDF first and then click on it.

CLICK HERE TO **DOWNLOAD** THE COMPLETE MANUAL

Insert cable harness (pay attention to the installation position, see arrow) and fasten by means of socket head screws.

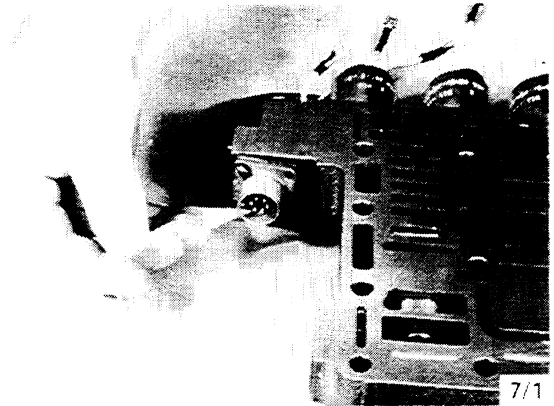

Fasten earth connecting cable (see arrow) and plug the single cables upon the solenoid valves.

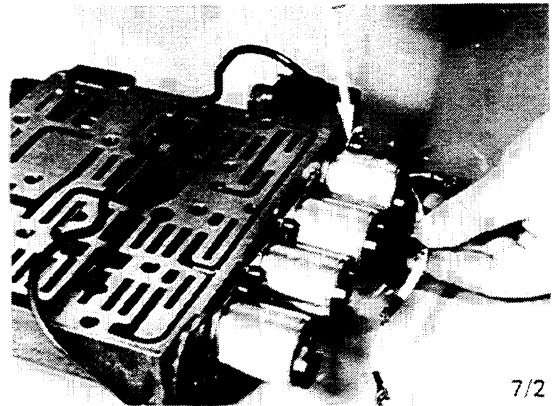

Insert O-ring into the cover and fix cover at the control unit by means of spring clip.

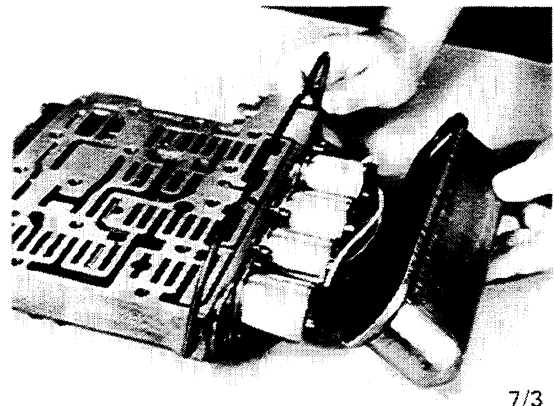

Reassembly of the two-stage valve:

Install piston and spring into the valve body and limit the travel of the piston by means of adjusting pin.

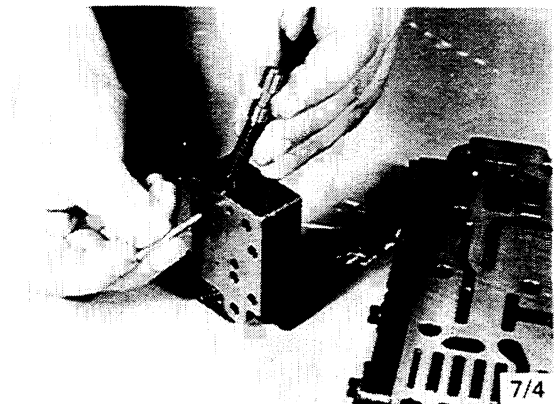

Remove needle bearing out of the piston carrier.

Remove on the opposite side of the piston carrier the piston of KV in the same way.

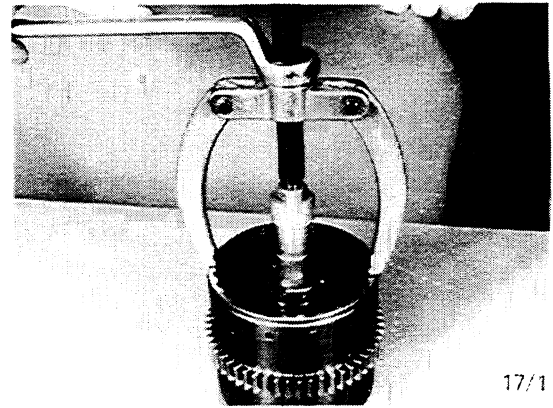

17/1

Take the clutch pack KR/K2 using supporting tool 75297586 with thrust washers towards below out of the housing.

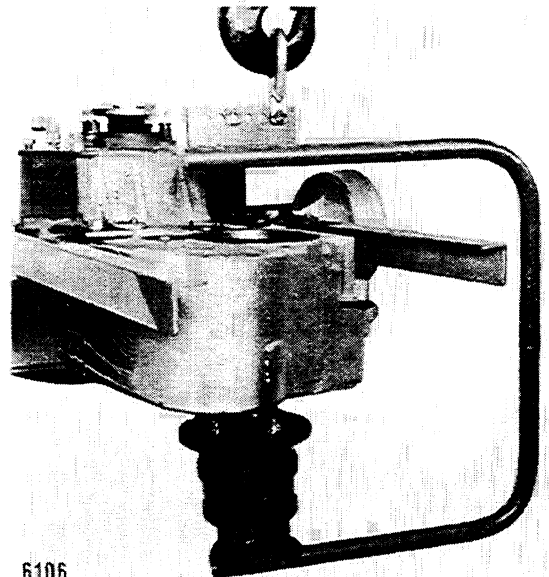

6106

Disassemble clutch pack KR/K2:

Remove spur gear 2nd speed with inserted bearings out of the plate carrier.

Pay attention to the arrangement of bearings and washers!

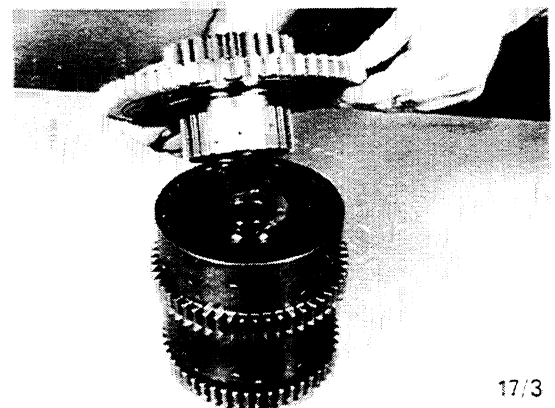

17/3

Illustration shows the spur gear with installed bearing inner race - see arrow!

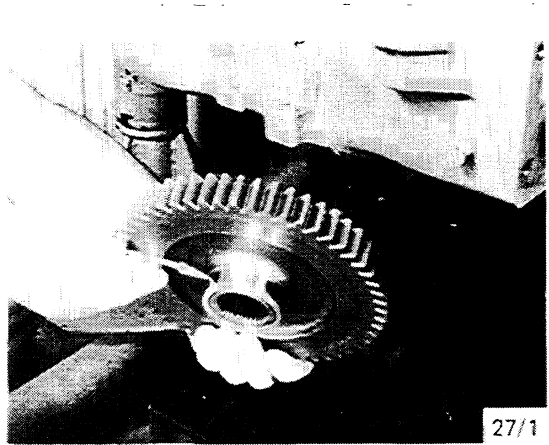

Insert the spur gear through the large housing bore into the installed roller bearing.

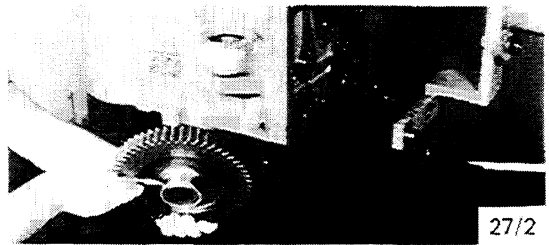

Engage circlip into the groove.

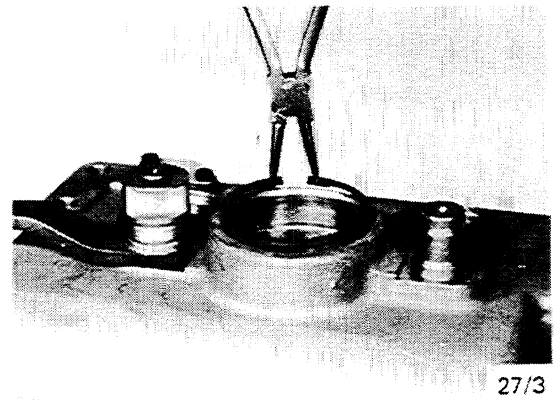

Place heated speedometer worm upon the drive shaft and introduce it into the spur gear.

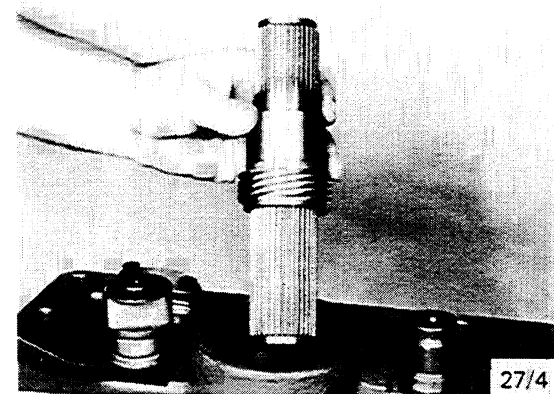

Place thrust plate upon the piston carrier and assemble spur gear/K4.



Install plate pack K3(short hub side of piston carrier).

Repeat same steps as with K4 - see page 35.

Outer plates = 10 pieces

Inner plates = 9 pieces

See also Section 1 "Clutch assembly specifications" page 14.

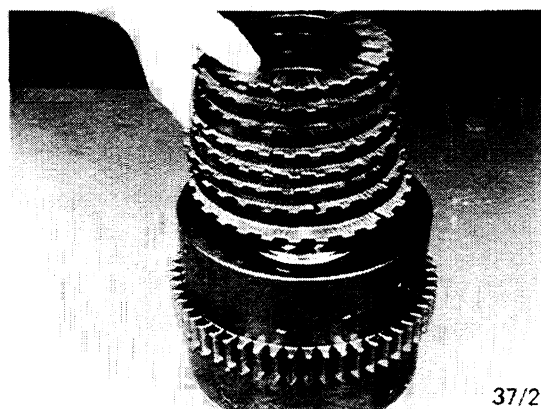
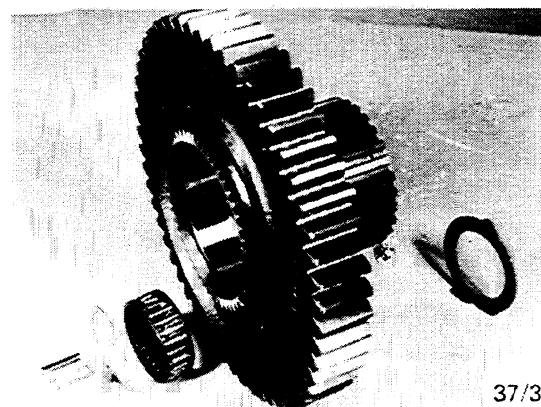
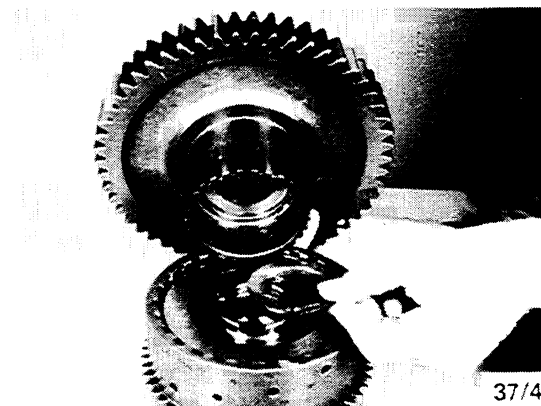

Illustration shows arrangement of the components in the spur gear K3.

Note: install components with grease!



Install thrust plate and assemble spur gear.



KV/K1:

Complete piston carrier as with
K3/K4 - see pages 33-34.

Assemble plate pack K1 (shorthubs of
piston carrier) as follows:

Insert 1 outer plate $s = 2,00$ mm
and lay inner plate $s = 2,50$ mm
upon it.

Insert alternating the remaining
outer plates (7 pieces) and inner
plates (6 pieces) - see also
Section for plate installation!

Install subsequently backing plate
and fix plate pack by means of
circlip.

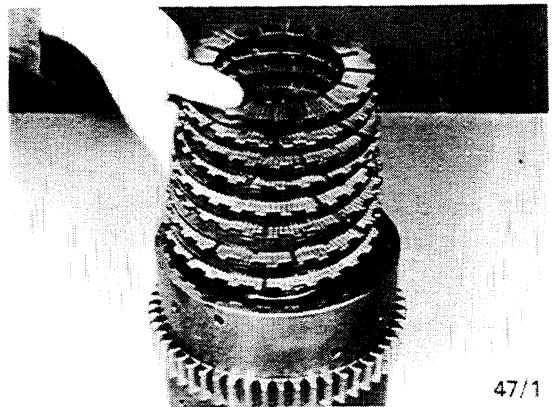

Check plate play:

Determine dimension A from face/
piston carrier to backing plate.

e.g. $5,40$ mm

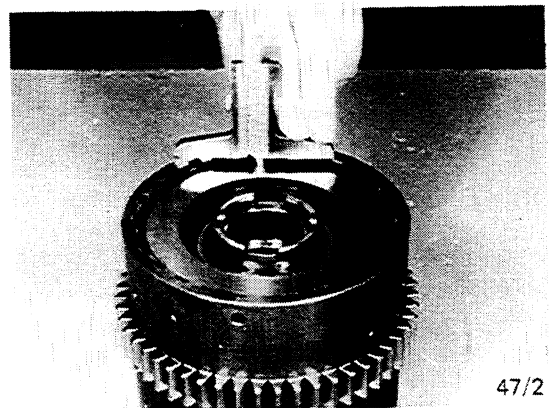

Position backing plate against
snap ring until contact is obtained.

Measure dimension B from face/ piston
carrier to backing plate.

e.g. $3,20$ mm

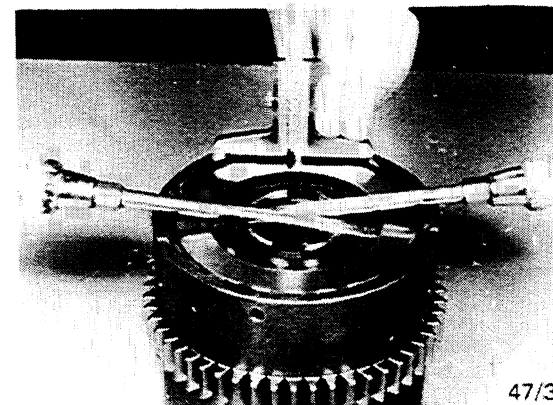

Insert adjusting spring - see arrow - into the groove of the output shaft.



Introduce pre-assembled output shaft into the pump and place bearing in the pump housing firmly against shoulder.

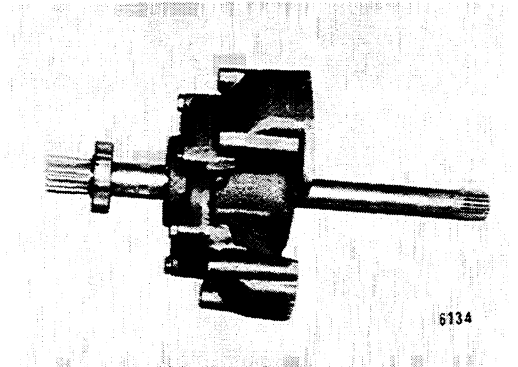

Guide ball bearing over the end of the output shaft and place it firmly against shoulder.

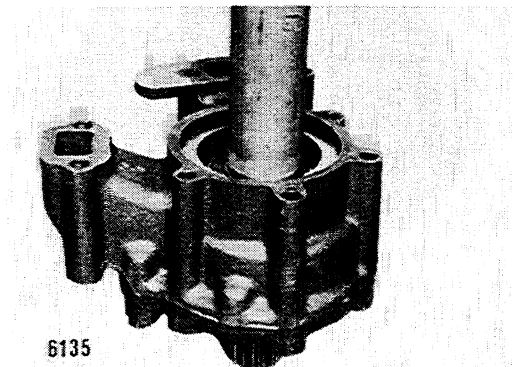

Note: closed bearing seat side on top!

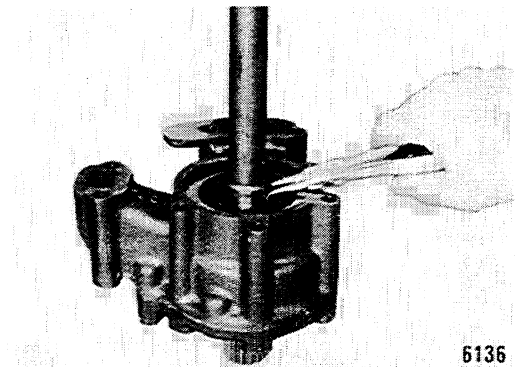

Engage circlip and engage rectangular ring into the recess and squeeze it into position.

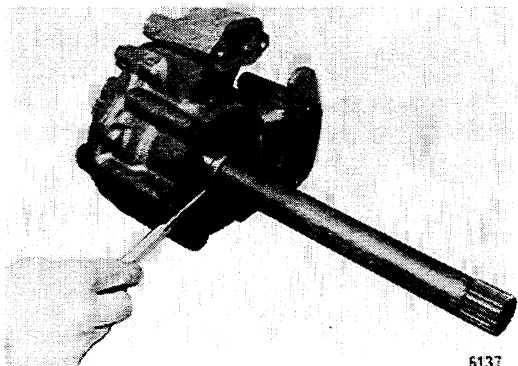

CLICK HERE TO **DOWNLOAD** THE COMPLETE MANUAL

- Thank you very much for reading the preview of the manual.
- You can download the complete manual from: www.heydownloads.com by clicking the link below



- Please note: If there is no response to CLICKING the link, please download this PDF first and then click on it.

CLICK HERE TO **DOWNLOAD** THE COMPLETE MANUAL