

# Workshop Service Manual

# Technician Service Book -

# MF 5600

GBA25  
GBA50  
GPA50

Electrical and hydraulics diagrams

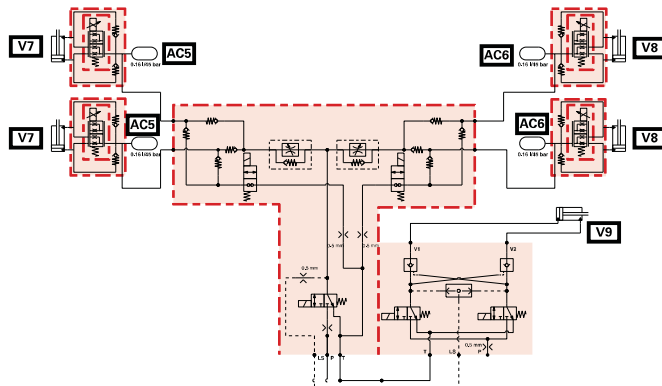
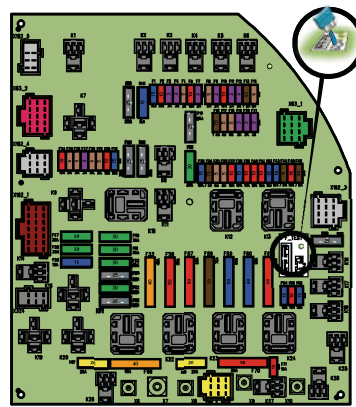

CLICK HERE TO **DOWNLOAD** THE COMPLETE MANUAL

- Thank you very much for reading the preview of the manual.
- You can download the complete manual from: [www.heydownloads.com](http://www.heydownloads.com) by clicking the link below



- Please note: If there is no response to CLICKING the link, please download this PDF first and then click on it.

CLICK HERE TO **DOWNLOAD** THE COMPLETE MANUAL

Steering	
Steering type	Hydrostatic
Type of control	Steering wheel
2-wheel drive Orbitrol displacement	80 cm <sup>3</sup> (4.88 in <sup>3</sup> )
4-wheel drive Orbitrol displacement	125 cm <sup>3</sup> (7.63 in <sup>3</sup> )
Steering ram diameter	36 mm (1.4 in) x 65 mm (2.6 in)
Steering ram stroke	2 x 105 mm (4.1 in)
Working pressure	175 bar (2538 psi) ± 5 bar (73 psi)
Pressure relief valve adjustment pressure	175 bar (2538 psi) ± 5 bar (73 psi)
Shock valve adjustment pressure	225 bar (3263 psi) to 245 bar (3553 psi)
Oil recommended for steering	According to MF CMS M1145 specification

Rear linkage	
Lift ram diameter	75 mm (3.0 in)
Maximum lifting capacity at ball joints	3330 kg (7341 lb)
Working pressure	180 bar (2611 psi)
3-point linkage category	2

Front linkage	
Lift ram diameter	80 mm (3.2 in) / 40 mm (1.6 in)
Maximum lifting capacity at ball joints	2236 kg (4929 lb)
Working pressure	190 bar (2756 psi)
3-point linkage category	2

Rear power take-off (PTO)	
Number of selections possible for rear PTO	540 540/540ECO 540/540ECO/1000
Rotational direction	Clockwise
Clutch type	Multidisc hydraulic
Control pressure	21 bar (305 psi)
Splined shaft type	6 or 21 x 1 <sup>3</sup> / <sub>8</sub> (diameter 35 mm (1.4 in)) splines or 20 x 1 <sup>3</sup> / <sub>4</sub> (diameter 45 mm (1.8 in)) splines

Front power take-off	
Number of selections possible for front PTO	1000 rpm
Rotational direction	Anti-clockwise
Clutch type	Multidisc hydraulic
Splined shaft type	6 or 21 x 1 <sup>3</sup> / <sub>8</sub> (diameter 35 mm (1.4 in)) splines

Electric	
Battery brand	TAB
Battery specifications	12 V - 105 A/H
Starter type	12 Volts
Alternator type	14 V/120 A

## 4 MF 5611 model

Engine	
Brand	AGCO Power
Type	44 AWI
Maximum power hp (kW) (ISO TR14396) at 2000 rpm	112 (82)
Maximum torque (ISO TR14396)	468 Nm (345 lbf ft)
Maximum PTO power hp (kW) (OECD) at PTO 1000 rpm	-
Idle speed	750/850 rpm
Maximum speed	2260 rpm
Engine weight	345 kg (761 lb)
Number of cylinders	4
Engine cubic capacity	4,4 l (1.2 gal (US))
Piston travel	120 mm (4.7 in)
Piston diameter	108 mm (4.3 in)
Compression ratio	17.4:1
Compression pressure	-
Injection pump brand	Bosch
Injection pump type	Common rail CP4.1
Firing order	1-2-4-3
Fuel prefilter filtration capacity	10 µ
Main fuel filter filtration capacity	5 µ
Recommended oil:	API CJ-4 or ACEA-E9
Lubrication system	By gear pump
Oil cooling system	Oil/water heat exchanger
Oil pressure at minimum speed	1 bar (15 psi)
Oil pressure at maximum speed	2,5 bar (36 psi) at 5 bar (73 psi) depending on the temperature
Relief valve adjustment pressure	5 bar (73 psi) (spring pressure)
Air suction type	Turbo air/air
Air preheating type	Grid Heater
Number of valves	4 per cylinder = 16
Inlet valve clearance value	0,35 mm (0.01 in) ± 0,05 mm (0.002 in)
Exhaust valve clearance value	0,35 mm (0.01 in) ± 0,05 mm (0.002 in)
Engine cooling system	Coolant
Fan type	Viscostatic
Thermostat begins to open at	83 °C (181 °F)
Liquid temperature from - to +	-35 °C (-31 °F) to 106 °C (223 °F)
Block preheater	110 or 220 volts
Fuel preheater	Not available

Rear axle transmission	
Gearbox type	GBA25
Transmission type	Dyna-4, Dyna-6
Number of gears	16 gears

Steering	
Steering type	Hydrostatic
Type of control	Steering wheel
2-wheel drive Orbitrol displacement	80 cm <sup>3</sup> (4.88 in <sup>3</sup> )
4-wheel drive Orbitrol displacement	125 cm <sup>3</sup> (7.63 in <sup>3</sup> )
Steering ram diameter	40 mm (1.6 in) x 70 mm (2.8 in)
Steering ram stroke	2 x 108 mm (4.3 in)
Working pressure	175 bar (2538 psi) ± 5 bar (73 psi)
Pressure relief valve adjustment pressure	175 bar (2538 psi) ± 5 bar (73 psi)
Shock valve adjustment pressure	225 bar (3263 psi) to 245 bar (3553 psi)
Oil recommended for steering	According to MF CMS M1145 specification

Rear linkage	
Lift ram diameter	85 mm (3.3 in)
Maximum lifting capacity at ball joints	4206 kg (9273 lb)
Working pressure	180 bar (2611 psi)
3-point linkage category	2

Front linkage	
Lift ram diameter	80 mm (3.2 in) / 40 mm (1.6 in)
Maximum lifting capacity at ball joints	2236 kg (4929 lb)
Working pressure	190 bar (2756 psi)
3-point linkage category	2

Rear power take-off (PTO)	
Number of selections possible for rear PTO	540 540/540ECO 540/540ECO/1000
Rotational direction	Clockwise
Clutch type	Electrohydraulic
Control pressure	21 bar (305 psi)
Splined shaft type	6 or 21 x 1 <sup>3</sup> / <sub>8</sub> (diameter 35 mm (1.4 in)) splines or 20 x 1 <sup>3</sup> / <sub>4</sub> (diameter 45 mm (1.8 in)) splines

Front power take-off	
Number of selections possible for front PTO	1000 rpm
Rotational direction	Anti-clockwise
Clutch type	Multidisc hydraulic
Splined shaft type	6 or 21 x 1 <sup>3</sup> / <sub>8</sub> (diameter 35 mm (1.4 in)) splines

Electric	
Battery brand	TAB
Battery specifications	12 V - 105 A/H
Starter type	12 Volts
Alternator type	14 V/120 A and optional 175 A

## **C - GTA5050 transmission dimensions and attachment points**

1	Dimensions and weights .....	39
2	Attachment points .....	41

**140 CP front axle**

Reference	Measured specification	140 CP front axle
(G)	Distance between flanges	1506 mm (59.3 in) to 2006 mm (79.0 in)
(H)	Centre-to-centre distance between studs	152,4 mm (6.0 in)
(I)	Centring diameter	117,42 mm (4.6 in)
(J)	Screw length	NC
(K)	Screw diameter	M16 x 1.5
(L)	Number of screws	6

**Rear axle**

Reference	Measured specification	GPA54 rear axle
(G)	Distance between flanges for GPA 54	1680 mm (66.2 in)
(H)	Centre-to-centre distance between studs	203,20 mm (8.0 in)
(I)	Centring diameter	149,35 mm (5.9 in)
(J)	Stud length	41 mm (1.6 in)
(K)	Stud diameter	M18 x 1.5
(L)	Number of studs	8

# 1 Retaining compounds and sealing products

## General

The Loctite compounds mentioned in this manual are referred to by their industrial name.

For repair purposes, use their commercial names or the corresponding Massey Ferguson references listed in the table below.

Loctite product type	Operation
221	Standard threadlock
241	
242	Medium threadlock
270	Strong threadlock
496	Glue (for metals)
510	Standard sealant
518	Sealant for flat surfaces and paper seals
542	Thread sealant
549	Oil-resistant surface sealant
573	Surface sealant (engine, gearbox)
574	
577	Threaded union sealant (prevents loosening and leakages caused by vibrations)
603	Retainer for cylindrical assemblies (bearings, rings etc.)
638	Strong retainer for cylindrical assemblies (bearings, rings etc.)
648	Strong retainer for cylindrical assemblies (resistant to high temperatures)
706	Degreasing cleaner
5206	Metallic surface sealant (gearbox housing, engine sump)
5910	± Flexible surface sealant
5922	Sealant paste for ± flexible unions (sensor attachments etc.)
7100	Leakage detector for pneumatic systems

**NOTE:** Use the product "Form A gasket 2" when sealing between plastic material and cast iron or steel.

## Application method for Loctite products

- Remove all traces of previous sealants and corrosion
  - mechanically: wire brush or emery cloth
  - chemically: "DECAPLOC 88" (Leave the product to take effect then scrape off and wipe clean).
- Degrease the components with dry solvent: preferably use "Super Solvant Sec LOCTITE 706".
- Allow the solvents to evaporate
- Apply the recommended type of LOCTITE product to the parts:
  - for blind tapped holes, apply a quantity of the product to the last threads at the bottom of the hole.
  - for cylindrical fittings, apply the product on the two mating faces using a clean brush.
  - for mating faces, apply a bead to one of the two faces, circling the holes, and then tighten as quickly as possible.

### NOTE:

- Do not use too much of the compound, in order to avoid locking adjacent parts.
- Do not attempt to retighten after 5 minutes of curing, in order to avoid breaking the film of compound.
- If the ambient temperature is less than +10 °C (50,00 °F), and to ensure quicker setting of Loctite products, (except SILICOMET), use LOCTITE T 747 activator after phase 2 on at least one of the two parts. Excess product outside the joint will not harden (anaerobic products — curing takes place only when there is no oxygen).

## 2 - Error codes

A	Indicator light panel .....	3
B	Error codes .....	11

## B - Error codes

1	Instrument panel error codes . . . . .	13
2	SisuDiesel Tier 4i engine error codes . . . . .	15
3	Transmission error codes for Dyna-4/Dyna-6 . . . . .	28
4	Power take-off error codes for Dyna-4/Dyna-6 . . . . .	31
5	Suspended front axle error codes. . . . .	32
6	Error codes for linkage without multifunction armrest . . . . .	33
7	Error codes for linkage with multifunction armrest . . . . .	34
8	Armrest error codes . . . . .	35
9	Hydraulic valve error codes. . . . .	36
10	Electrohydraulic unit error codes for spool valves 1 and 2 . . . . .	37
11	Air conditioning error codes . . . . .	38

No.		F MI	Components concerned	Causes	Standard modes	EGR/SCR Technology modes
E	3031	10	AdBlue™ or DEF tank temperature sensor	Abnormal rate change during heating cycle		SCR Technology
E	3031	14	AdBlue™ or DEF tank temperature sensor	Deicing time exceeded		SCR Technology
E	3031	16	AdBlue™ or DEF tank temperature sensor	Temperature above normal		SCR Technology
E	3349	8	CAN bus	Torque and speed control delay has been exceeded		
E	3361	3	AdBlue™ or DEF metering module	Low side short-circuited to +12 V		SCR Technology
E	3361	4	AdBlue™ or DEF metering module	High side short-circuited		SCR Technology
E	3361	5	AdBlue™ or DEF metering module	High side short-circuited to +12 V or open circuit		SCR Technology
E	3361	6	AdBlue™ or DEF metering module	Low side short-circuited to earth (-) or open circuit		SCR Technology
E	3361	11	AdBlue™ or DEF metering module			
E	3361	14	AdBlue™ or DEF metering module	Abnormal operation		SCR Technology
E	3361	31	AdBlue™ or DEF metering module	Operating temperature too high		
E	3363	3	AdBlue™ or DEF tank pre-heating liquid control valve	Short circuit to +12 V		SCR Technology
E	3363	4	AdBlue™ or DEF tank pre-heating liquid control valve	Shortcut to Ground		SCR Technology
E	3363	5	AdBlue™ or DEF tank pre-heating liquid control valve	Open circuit		SCR Technology
E	3363	31	AdBlue™ or DEF tank pre-heating liquid control valve	Excessive temperature		SCR Technology
E	3509	31	EEM4 controller	5 V DC supply 1 out of range		
E	3510	31	EEM4 controller	5 V DC supply 2 out of range		
E	3511	31	EEM4 controller	5 V DC supply 3 out of range		
E	3512	3	EEM4 controller	12 V supply 1 above normal		
E	3512	4	EEM4 controller	12 V supply 1 below normal		
E	4090	16	AdBlue™ or DEF system	NOx emissions value too high		SCR Technology
E	4090	18	AdBlue™ or DEF system	NOx emissions value not permitted		SCR Technology
E	4201	2	Crankshaft speed sensor	Irregular signal	2	
E	4201	31	Crankshaft speed sensor	No signal	2	
E	4332	0	AdBlue™ or DEF system	Excess pressure detected		SCR Technology
E	4332	11	AdBlue™ or DEF system	Metering pump fault		SCR Technology

## 4 Power take-off error codes for Dyna-4/Dyna-6

No.	Components concerned	Causes
T141	<b>X7</b> - Rear PTO solenoid valve	Short circuit to +12 V
T142	<b>X7</b> - Rear PTO solenoid valve	Open circuit
T143	<b>X7</b> - Rear PTO solenoid valve	Short circuit to 0 V
T144		Excessive drop in PTO engine speed
T145		PTO switch is activated but the PTO is not activated
T146		Engine speed too high (> 1780 rpm) in economy PTO mode
T147		PTO clutch power too high

## **3 - Fuse box, electrical diagrams, harnesses, hydraulics diagrams and pneumatic diagrams**

A	Fuse box, electrical diagrams and harnesses .....	3
B	Hydraulics diagrams .....	353
C	Pneumatic diagrams .....	373











# 1 Fuse box

## 1.1 Description of fuse boxes for MF 5608/MF 5609/MF 5610 tractors

### Functions of the fuse box elements

F	Fuse
SH	Shunt (shunts are fuses)
K	Relay
X	Connector

### Fuse power and size

Amperage	Size	Color
3	Small	
5	Small	
7.5	Small	
10	Small	
15	Small	
15	Average	
20	Average	
(25)	Average	
(30)	Average	
(50)	Large	
(60)	Large	

Number	Amperage	Size	Protected function
F1	5A	Small	Fuse board earth
F2	3 A	Small	Functions <ul style="list-style-type: none"> <li>- K6 relay control circuit supplying the +ACC<sup>(1)</sup> for the tractor</li> <li>- Battery isolator "wake-up" via the +ACC<sup>(1)</sup> position of the ignition key</li> </ul>
F3	10 A	Small	Radio supply +BAT <sup>(3)</sup>
F4	15 A	Small	Power supply: <ul style="list-style-type: none"> <li>- Rear windscreen wiper motor and switch</li> <li>- Extreme cold weather pump motor</li> </ul>
F5	25 A	Average	Front windscreen wiper motor and control unit
F6	25 A	Average	Main beam lights on hand rail and grille
F7	15 A	Small	Dipped beam lights on hand rail and grille
F8	30 A	Average	Right-hand pillar power socket + BAT <sup>(3)</sup>
F9	10 A	Small	K17 relay power circuit supplying + BAT <sup>(3)</sup> for the hydraulic-pumps coupling solenoid valve
F10	5 A	Small	Battery circuit breaker and emergency stop switch
F11	15 A	Small	Switches for functions 3 and 4 on Multi Function Joystick
F12	10 A	Small	Functions <ul style="list-style-type: none"> <li>- K6 relay power circuit supplying the +ACC<sup>(1)</sup> for the tractor</li> <li>- Battery circuit breaker +ACC<sup>(1)</sup></li> </ul>
F13	5 A	Small	Auto-Guide™ + BAT <sup>(3)</sup>
F14	10 A	Small	Right-hand pillar power socket +APC <sup>(2)</sup>
F15	30 A	Average	Hazard warning light unit +BAT <sup>(3)</sup>
F16	25 A	Average	<ul style="list-style-type: none"> <li>- Work lights on hand rails</li> <li>- Work lights on fenders</li> <li>- Indicator light for work lights</li> </ul>
F17	30 A	Average	<ul style="list-style-type: none"> <li>- Work lights on bottom hand rails</li> <li>- Work light on front power socket</li> <li>- Information about the work light module on the bottom hand rail</li> </ul>
F18	20 A	Average	<ul style="list-style-type: none"> <li>- Roof rotary beacons</li> <li>- Rotary beacon on front power socket</li> <li>- Keypad information for rotary beacons on roof and on front power socket</li> </ul>
F19	25 A	Average	<ul style="list-style-type: none"> <li>- Work lights at rear of roof</li> <li>- Information about the work light module at rear of roof</li> </ul>
F20	30 A	Average	<ul style="list-style-type: none"> <li>- Work lights at front of roof</li> <li>- Information about the work light module at front of roof</li> </ul>
F21	30 A	Average	+ BAT <sup>(3)</sup> Work light module on grille
F22	50 A	Large	Not used
F23	60 A	Large	K28 relay power circuit supplying the + BAT <sup>(3)</sup> to the Isobus connectors
F24	50 A	Large	Isobus connector outside cab +BAT <sup>(3)</sup>

- X85** - Trailer connection side lights NA/left-hand side light EEC
- X86** - Trailer connection for 20-A power socket NA/Reversing light EEC
- X87** - Linkage lifting/lowering switch on right-hand fender (ML260)
- X87** - Linkage lifting switch on right-hand fender
- X88** - Rear right-hand indicator light extension NA
- X89** - Earth (chassis)
- X90** - Pillar harness/left-hand fender harness junction
- X91** - Rear left-hand indicator
- X92** - Rear left-hand side light and stop light
- X93** - Work light on rear left-hand fender
- X94** - PTO switch on left-hand fender
- X95** - Hydraulic spool valve switch on right-hand fender
- X96** - Hydraulic spool valve switch on left-hand fender
- X97** - Linkage lifting/lowering switch on left-hand fender (ML260)
- X97** - Linkage lifting switch on left-hand fender
- X98** - Rear left-hand indicator light extension NA
- X99** - PTO and linkage console harness/cab transmission harness junction
- X100** - Instrument panel harness earth (chassis)
- X101** - Instrument panel harness/electric rear-view mirror harness junction
- X102** - Right-hand fender lighting harness/trailer connector harness junction
- X103** - Armrest harness/cab transmission harness junction
- X104** - Autotronic 5 TECU
- X105** - Datatronic CCD
- X106** - T-handle
- X107** - Headland mode switch (Headland Management function)
- X108** - FingerTIP 3
- X109** - FingerTIP 4
- X110** - FingerTIP 5
- X110** - FingerTIP 6
- X111** - Dyna-TM dynamic transmission mode switch
- X112** - Joystick
- X113** - 6-button keypad on armrest
- X114** - Supply on fuse box for 3<sup>rd</sup> spool valve
- X115** - Supply on fuse box for 4<sup>th</sup> spool valve
- X116** - +12 V battery supply (for lighting module)
- X117** - Isobus +12 V battery power socket
- X118** - Automatic power take-off switch
- X119** - Rear linkage lifting/lowering switch
- X120** - Datatronic CCD navigation keyboard
- X121** - Rear linkage height/depth adjustment thumb wheel
- X122** - Hand throttle
- X123** - High/low speed range (Hare/Tortoise) shift switch
- X124** - Pedal/Lever mode switch
- X125** - SV1 speed setting potentiometer
- X126** - SV2 speed setting potentiometer
- X127** - Front PTO ON/OFF switch

## 2.2 Identification of electrical connectors from X501 to X1000

---

- X501** - PTO 2
- X502** - PTO 3
- X503** - PTO 4
- X504** - Cab transmission harness/console harness junction
- X505** - Valve relay for SCR Technology engine
- X506** - Engine harness/extreme cold additional harness (urea) junction
- X507** - Extreme cold water pump
- X508** - Transformer 230 V/12 V
- X509** - 10-A in-line fuse
- X510** - Valtra Terminal
- X511** - Italian number plate light
- X512** - Additional heater switch
- X513** - Additional heater assembly
- X514** - Front left-hand ram supply
- X515** - Front right-hand ram supply
- X516** - Rear left-hand ram supply
- X517** - Rear right-hand ram supply
- X518** - Front supply
- X519** - Rear supply
- X520** - Front solenoid valve
- X521** - Rear solenoid valve
- X522** - Front left-hand ram sensor
- X523** - Front right-hand ram sensor
- X524** - Rear left-hand ram sensor
- X525** - Rear right-hand ram sensor
- X526** - Reverse station Autotronic 5
- X527** - Reverse station brake pedal
- X528** - Reverse station Power Control lever
- X529** - Reverse station throttle pedal
- X530** - Reverse station clutch pedal
- X531** - Seat position sensor
- X532** - Connection 1 of the steering position controller
- X533** - Reverse station operation indicator light
- X534** - Reverse station harness/steering column junction
- X535** - Reverse station harness/transmission harness junction
- X536** - Connection 2 of the steering position controller
- X537** - Reverse station ParkLock switch
- X538** - Quick access switch on tractor terminal
- X539** - Power-assisted steering setting potentiometer
- X540** - Reverse station harness/steering column junction
- X541** - Temperature info shunt for automatic air-conditioning
- X542** - Windscreen washer pump
- X543** - Range display
- X544** - AutoDrive
- X545** - Range switch

**EFD00140\_41** - High beam lamps and low beam lamps on grille and hand rails for tractors with linkage controls in the right-hand pillar

**EFD00141\_72** - Work lights for tractors with linkage controls in the right-hand pillar

**EFD00141\_74** - Work lights and high beam lamps on hand rails for tractors with linkage controls in the right-hand pillar

**EFD00141\_83** - Work lights for tractors with linkage controls in the right-hand pillar

**EFD00141\_84** - Work lights and high beam lamps on hand rails for tractors with linkage controls in the right-hand pillar

**EFD00142\_8** - Dyna-4/Dyna-6 brake lights

**EFD00142\_9** - Dyna-4 brake lights

**EFD00143\_27** - Rotary beacon for tractors with linkage controls in the right-hand pillar

**EFD00144\_8** - Control module located in the right-hand pillar and including linkage controls

**EFD00145\_13** - NA trailer connector

**EFD00145\_14** - EAME trailer connector

**EFD00146\_9** - Automatic air conditioning backlighting

**EFD00146\_10** - Manual air conditioning backlighting

**EFD00146\_11** - Manual air conditioning backlighting for tractors with high-visibility roof

**EFD00172\_6** - Front accessory connection socket

### **Engine function**

**EFD00148\_10** - Horn

**EFD00148\_11** - Horn

**EFD00149\_12** - EGR battery charging + starting

**EFD00149\_14** - Battery charging + starting

**EFD00150\_8** - Air filter vacuum sensor

**EFD00151\_21** - AGCO Power engine electronic injection for tractors with multifunction armrest

**EFD00151\_22** - AGCO Power engine electronic injection for tractors without multifunction armrest

**EFD00152\_14** - DANA suspended front axle

**EFD00154\_4** - Fuel preheater

**EFD00173\_5** - Sensor detecting water in the fuel

**EFD00175\_4** - EGR system - Engine installation

**EFD00175\_6** - SCR Technology

### **Linkage function**

**EFD00160\_24** - Open Center rear linkage 57 l (15.1 gal (US)) Dyna-4 for tractors without multifunction armrest

**EFD00160\_25** - Open Center rear linkage 100 l (26.4 gal (US)) Dyna-4 for tractors without multifunction armrest

**EFD00160\_26** - Open Center rear linkage 57 l (15.1 gal (US)) Dyna-4 and Dyna-6 for tractors with municipal cab

**EFD00160\_27** - Open Center rear linkage 100 l (26.4 gal (US)) Dyna-4 and Dyna-6 for tractors with municipal cab

**EFD00161\_10** - Dyna-6 and Dyna-4 front linkage

**EFD00161\_11** - Dyna-6 and Dyna-4 front linkage

**EFD00172\_6** - Front accessory connection socket

**EFD00176\_9** - Mechanical ALO loader

**EFD00176\_11** - Mid Mounted pack

**2.9 EFD00101\_15 - Dyna-4 differential lock**

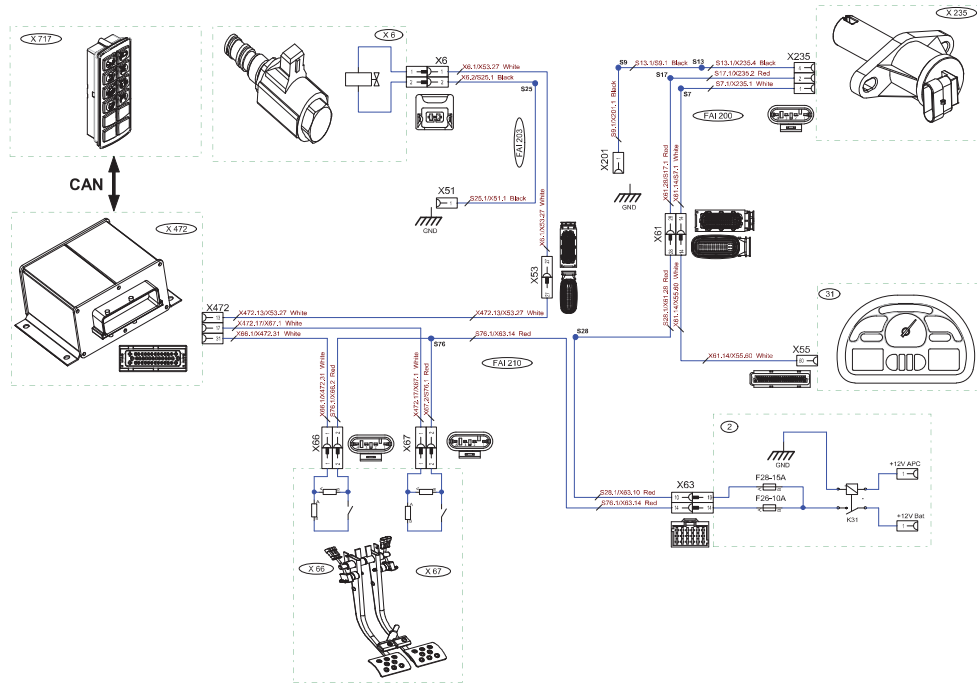

Fig. 16.

EFD00101\_15

B035230

2.19 EFD00111\_27 - Dyna-6 GTA2550 Open Center transmission\_3/4 (short console)

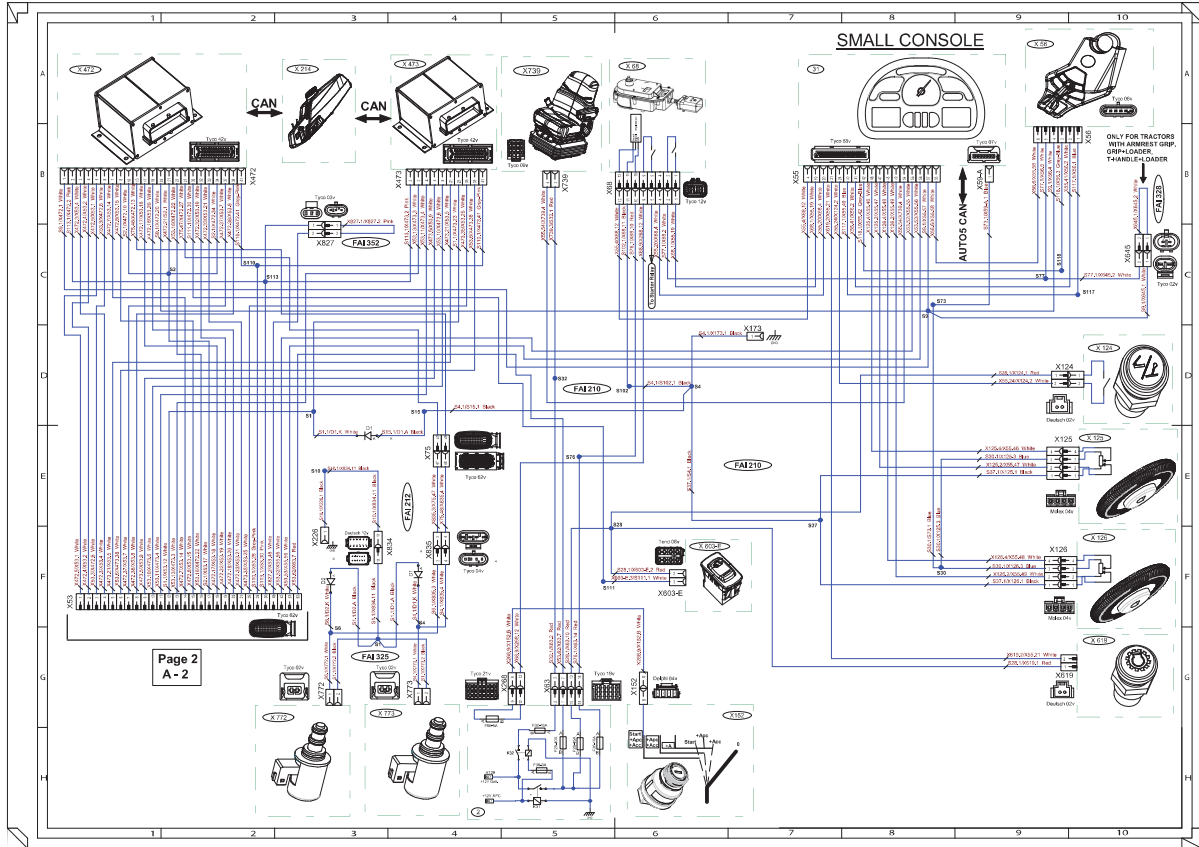

Fig. 26.

EFD00111\_27\_3/4

B044038

2.29 EFD00117\_28 - Additional heater

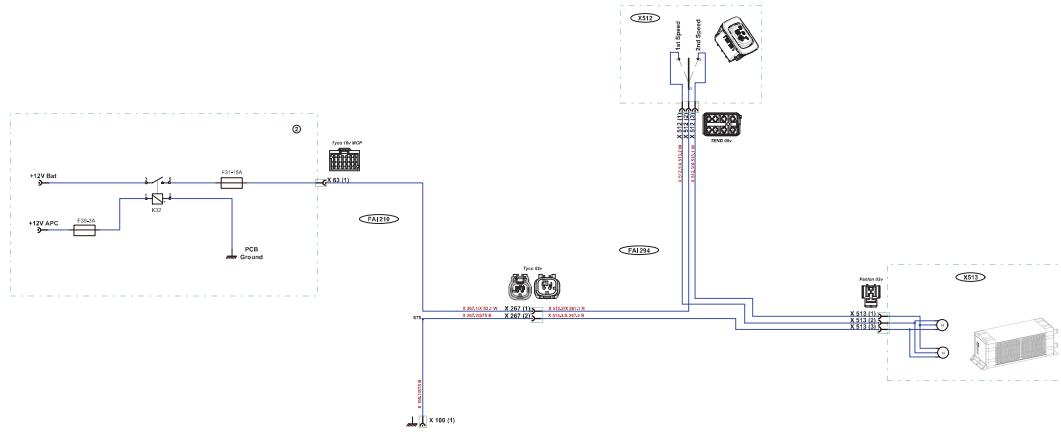

Fig. 36.

EFD00117\_28

032311

**2.39 EFD00121\_11 - Dyna-4 parking brake**

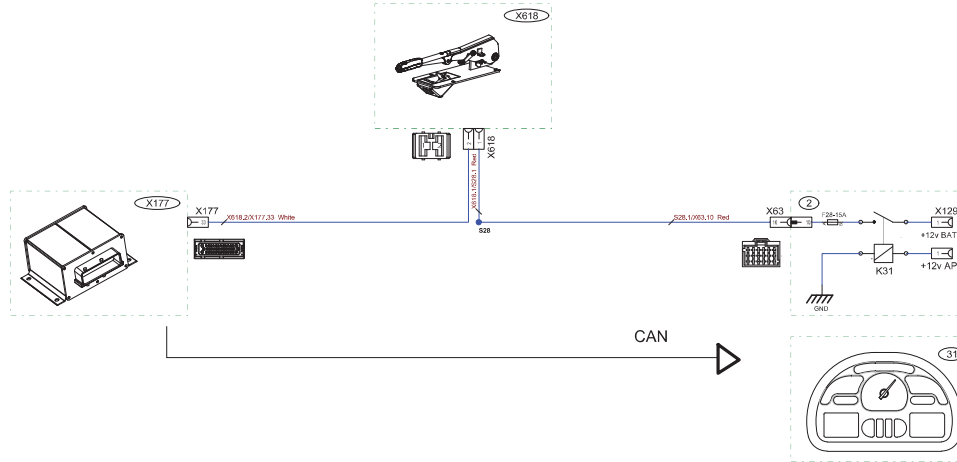

Fig. 46.

EFD00121\_11

B035280



**2.57 EFD00131\_29 - Dyna-6 and Dyna-4 CAN network\_1/6 with linkage control in the pillar (tractor CAN for tractors with multifunction armrest)**

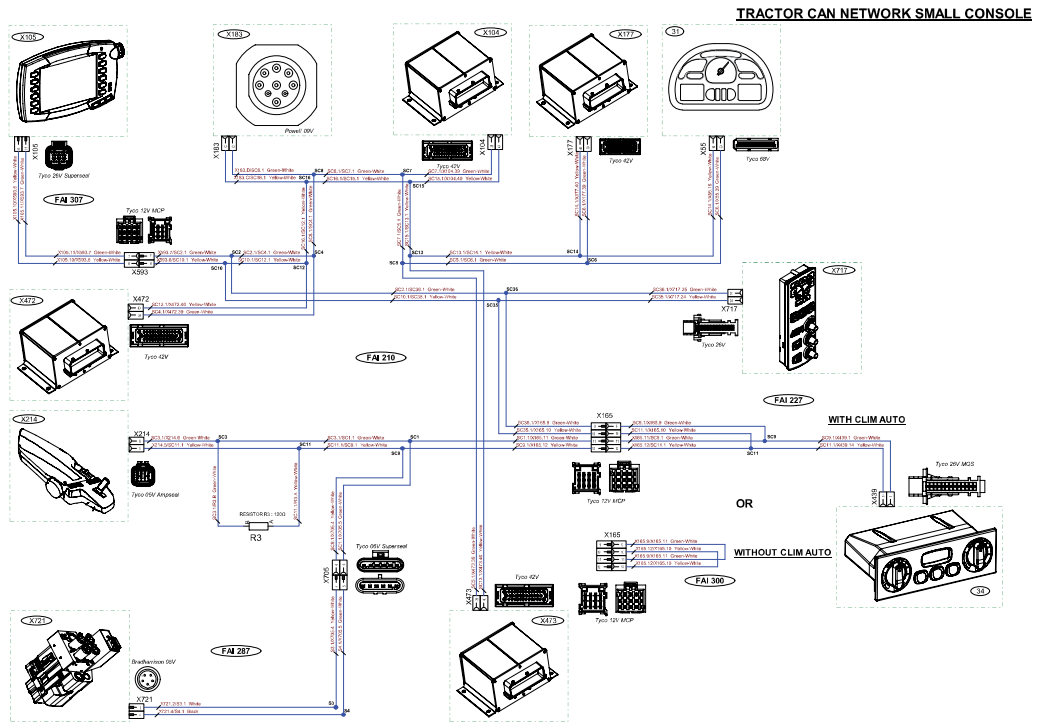

Fig. 64.

EFD00131\_29

B042899



**2.77 EFD00136\_53 - Indicators and hazard warning lights for tractors with high-visibility roof and linkage controls in the right-hand pillar — NA**

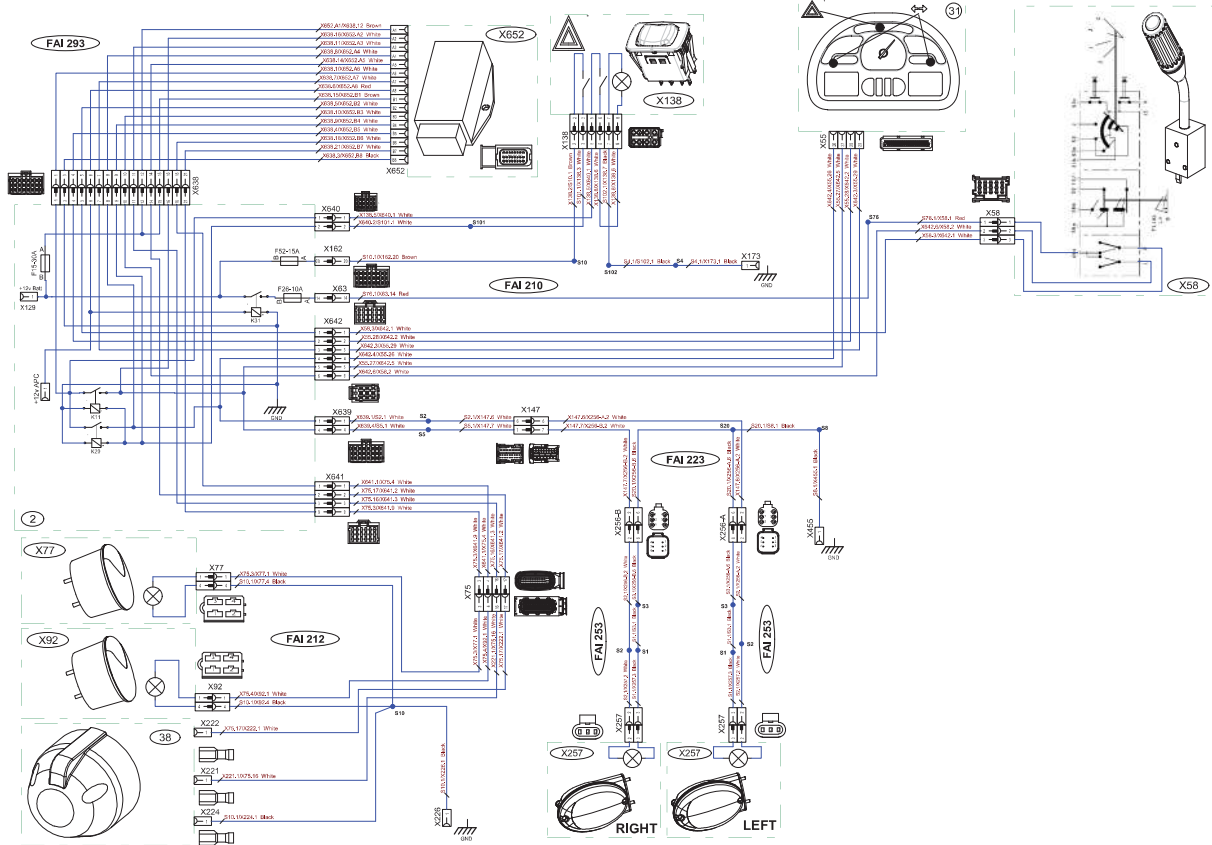

Fig. 84.

EFD00136\_53

1044212

CLICK HERE TO **DOWNLOAD** THE COMPLETE MANUAL

- Thank you very much for reading the preview of the manual.
- You can download the complete manual from: [www.heydownloads.com](http://www.heydownloads.com) by clicking the link below



- Please note: If there is no response to CLICKING the link, please download this PDF first and then click on it.

CLICK HERE TO **DOWNLOAD** THE COMPLETE MANUAL

**2.87 EFD00140\_36 - High beam lamps and low beam lamps on grille for tractors with linkage controls in the right-hand pillar**

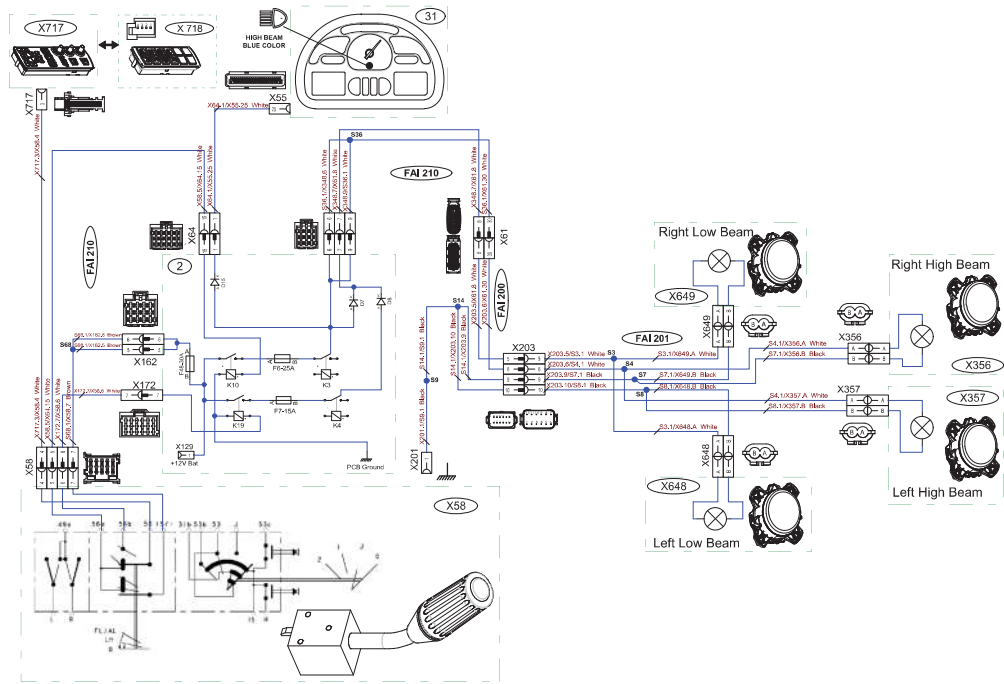

Fig. 94.

EFD00140\_36

B035341

**2.97 EFD00143\_27 - Rotary beacon for tractors with linkage controls in the right-hand pillar**

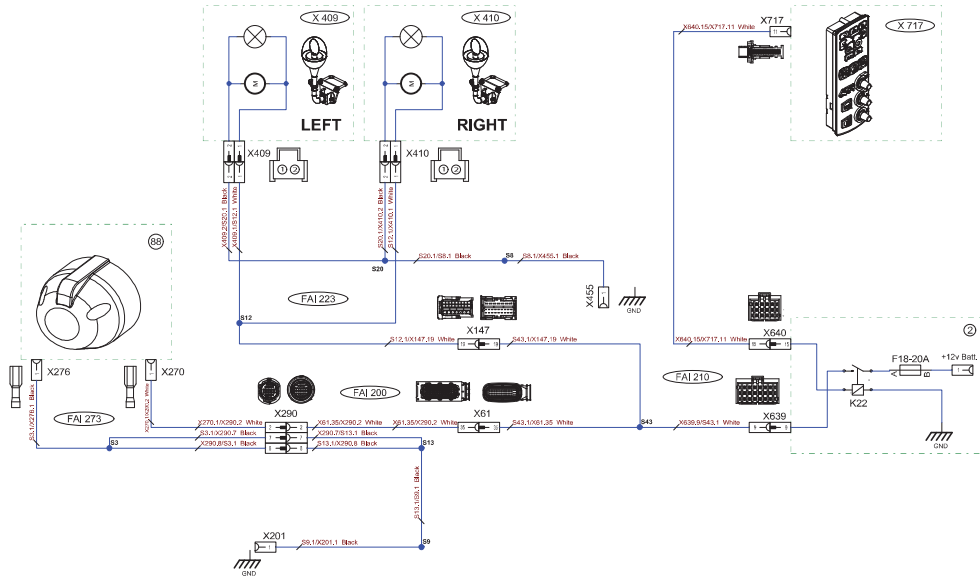

Fig. 104.

EFD00143\_27

B035355



**2.117 EFD00154\_4 - Fuel preheater**

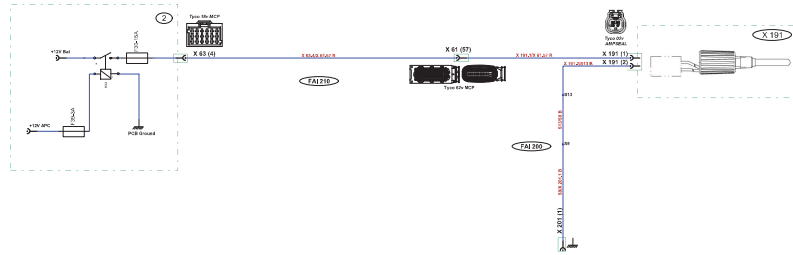

Fig. 124.

EFD00154\_4

B032-029

2.127 EFD00169\_15 - Dyna-6 and Dyna-4 controller power supply\_4/4

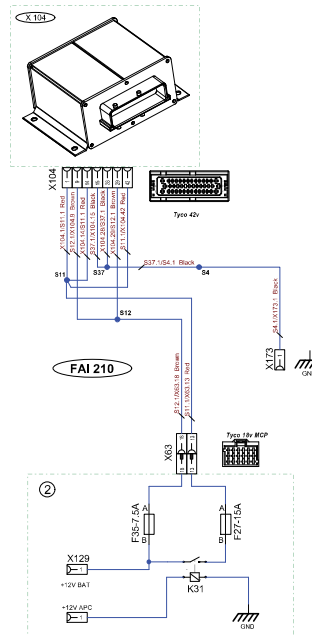

Fig. 134.

EF00069\_15

1042610



**3.2 FAI200 - Engine harness - steering angular sensor - 4382431\_1/2**

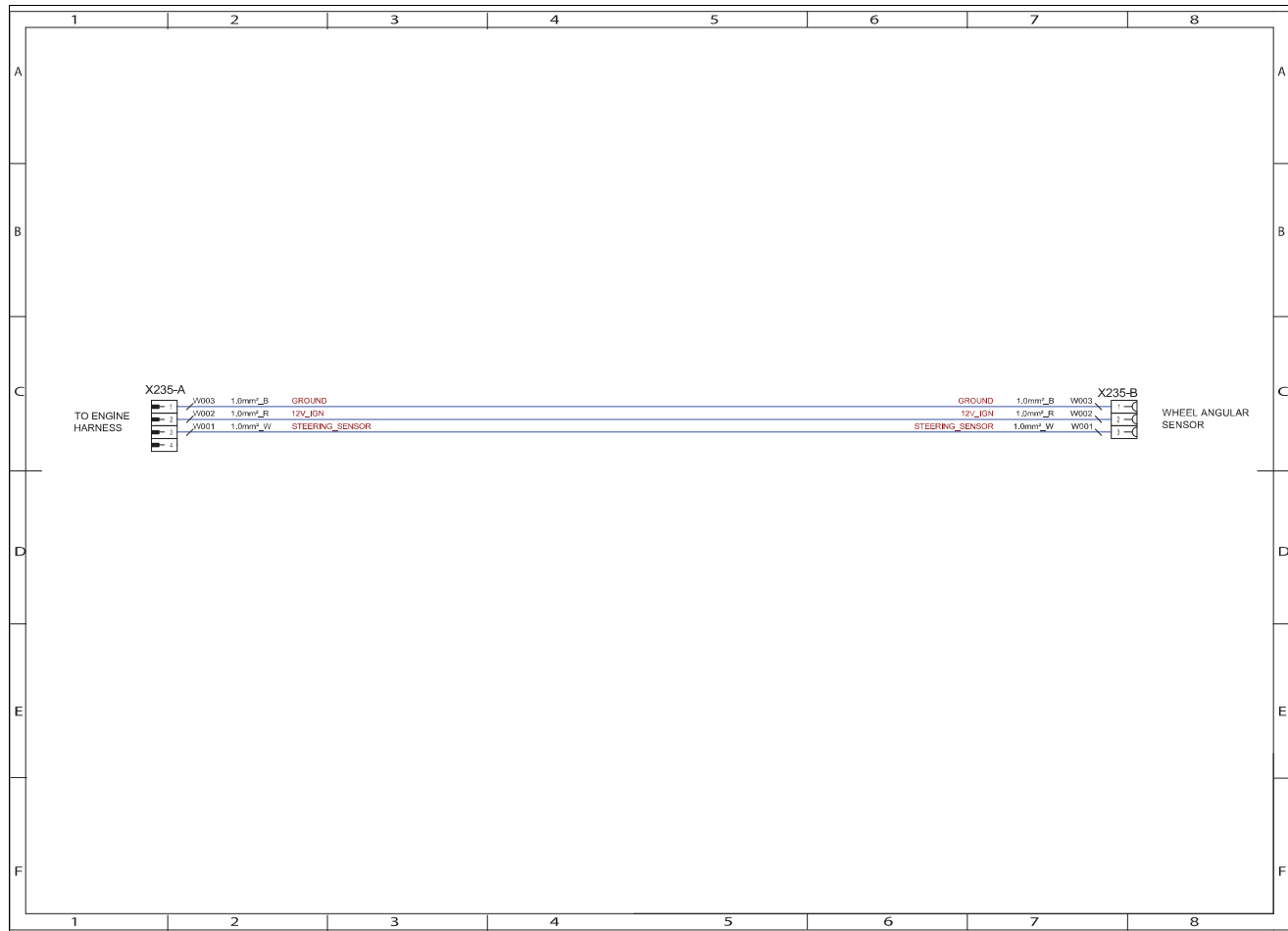
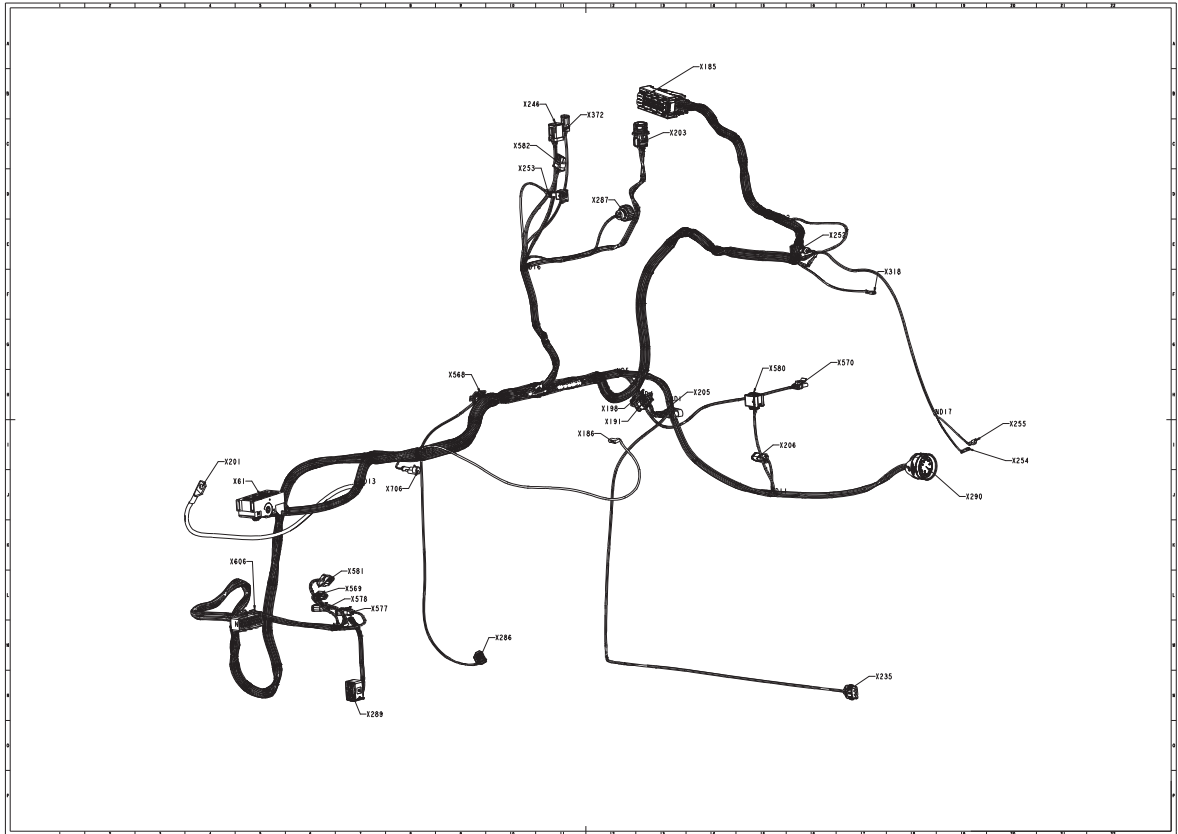

Fig. 151.

FM200-4382431M1-01\_10

0039442

### 3.12 FAI200 - Engine harness - Tier4i 4 cylinders - 4379583\_4/4



FAI200-4379583-02\_2/5

Fig. 161.

B045/80

### 3.22 FAI202 - Suspended front axle harness - 4380434\_2/2

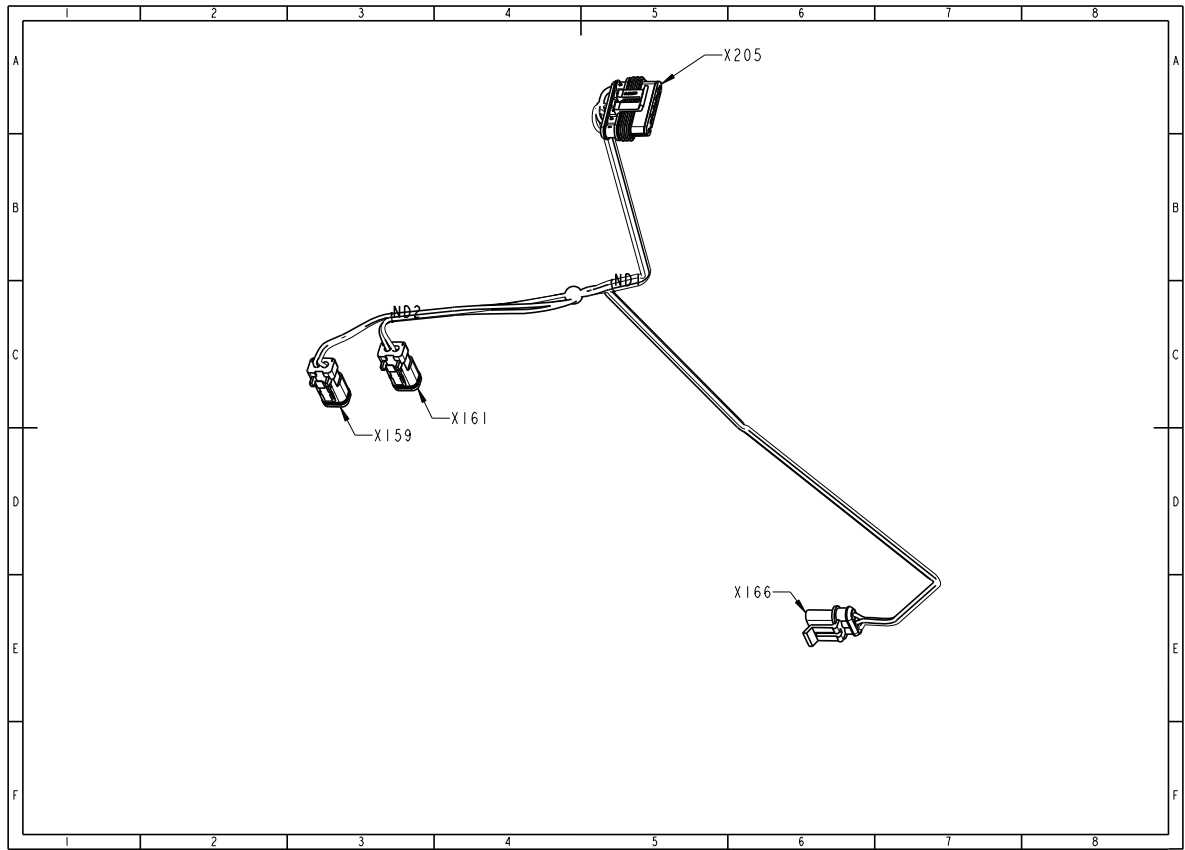

FAI202-4380434M-F01\_2/2

Fig. 171.

B045/81

**3.32 FAI210 - Cab transmission harness - Dyna-6 long console - 4374075\_4/8**

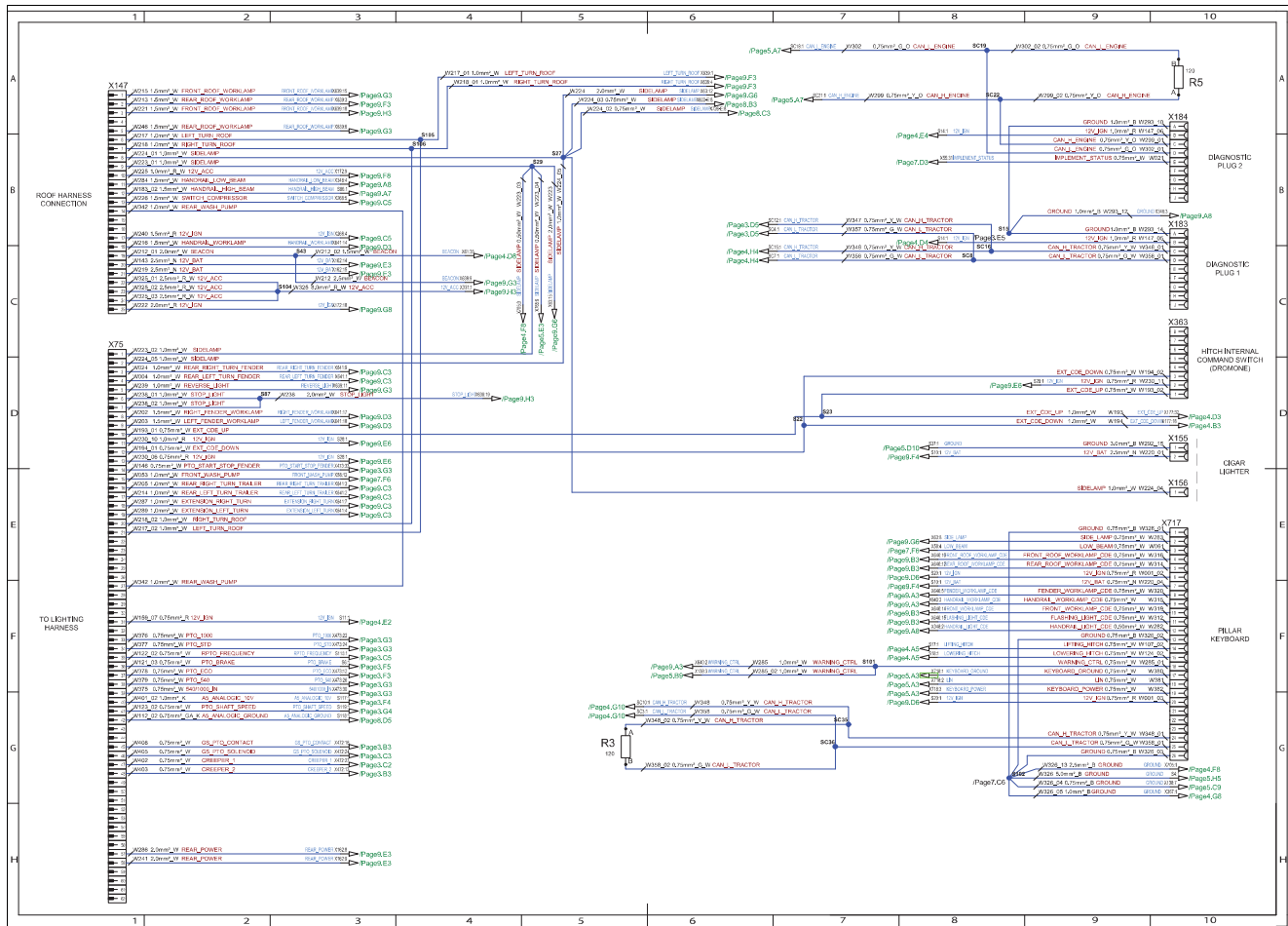

Fig. 181.

FAI210-4374075M5-05\_09

1039413





**3.62 FAI210 - Cab transmission harness Dyna-6 - 4378779\_4/8**

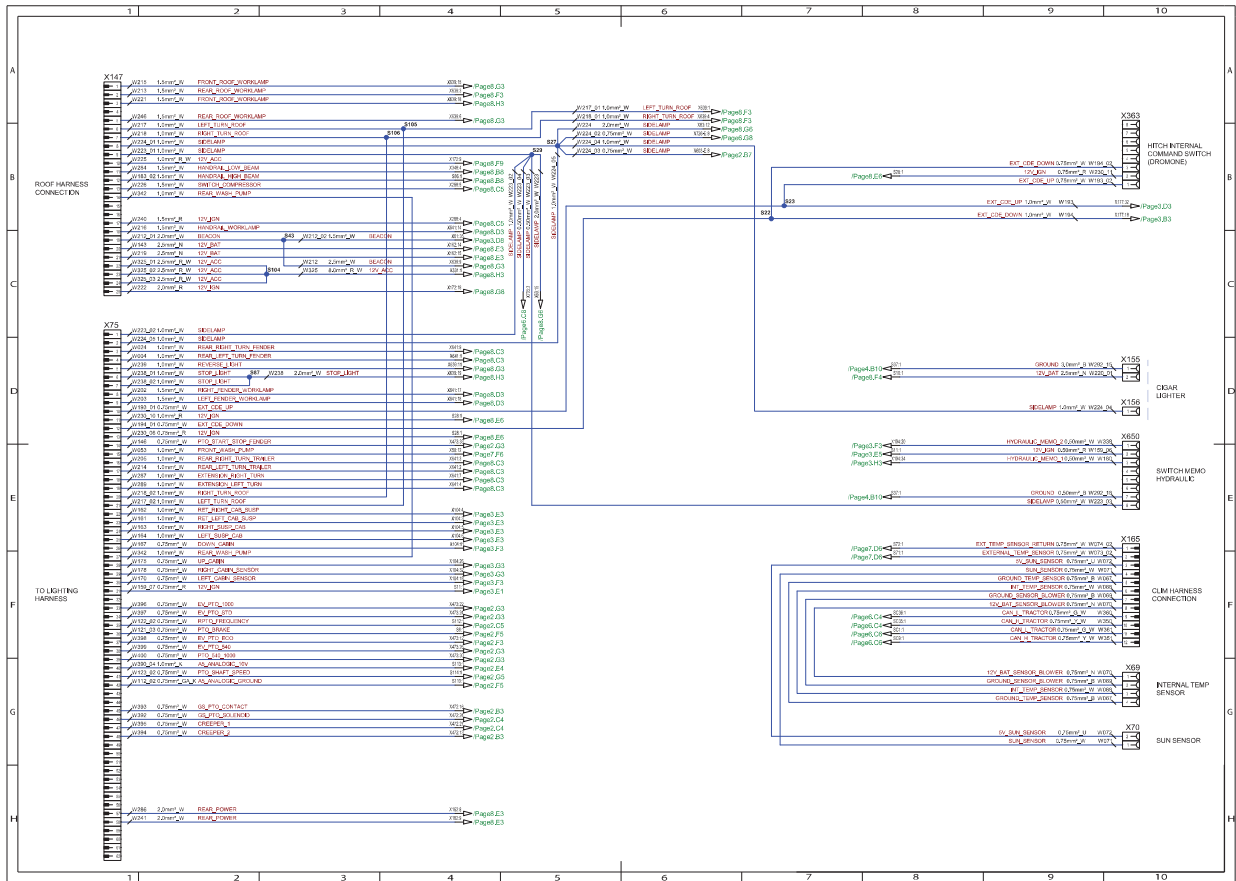

Fig. 211.

B042/08

3.72 FAI212 - Lighting harness EAME - 4377264\_3/3

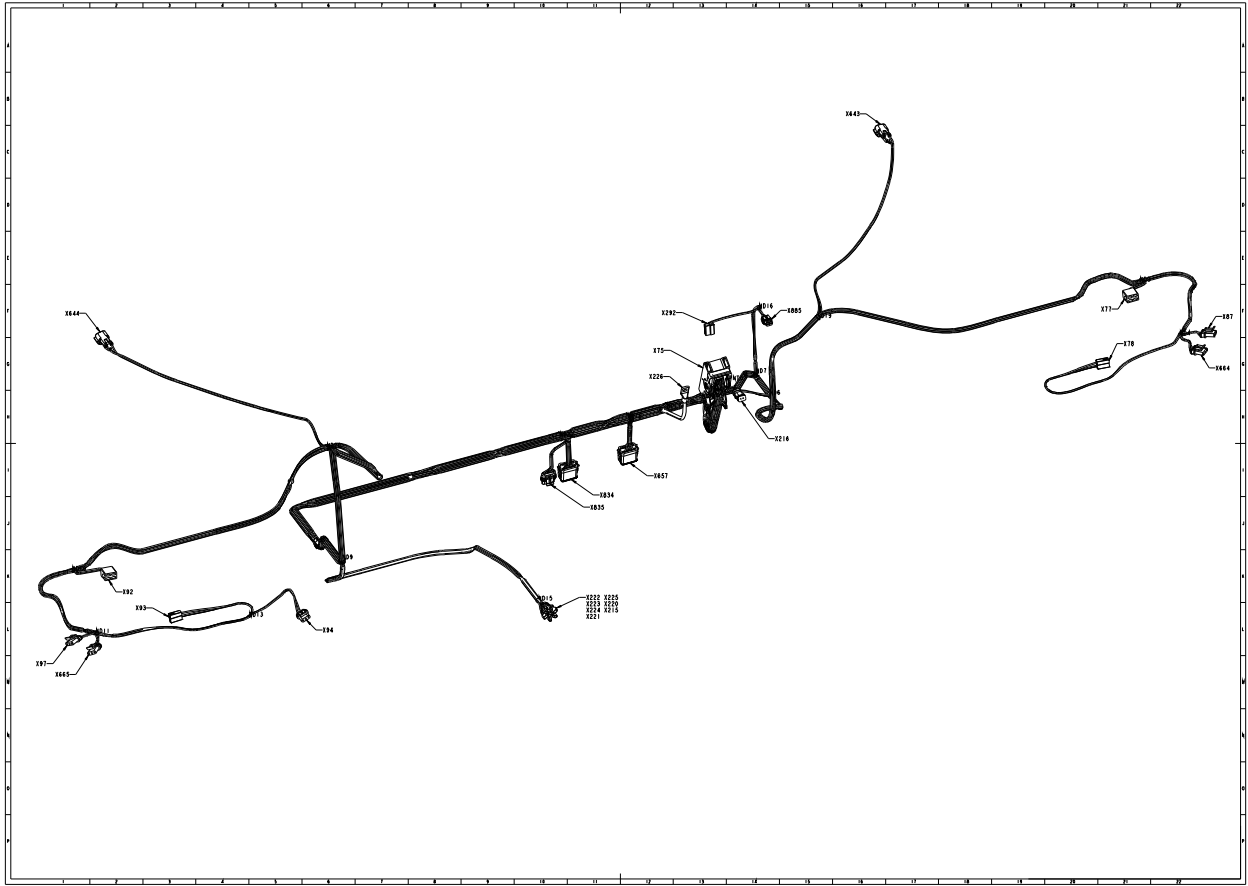

Fig. 221.

1042/50

3.82 FAI223 - Roof harness high visibility - 4375395\_3/3

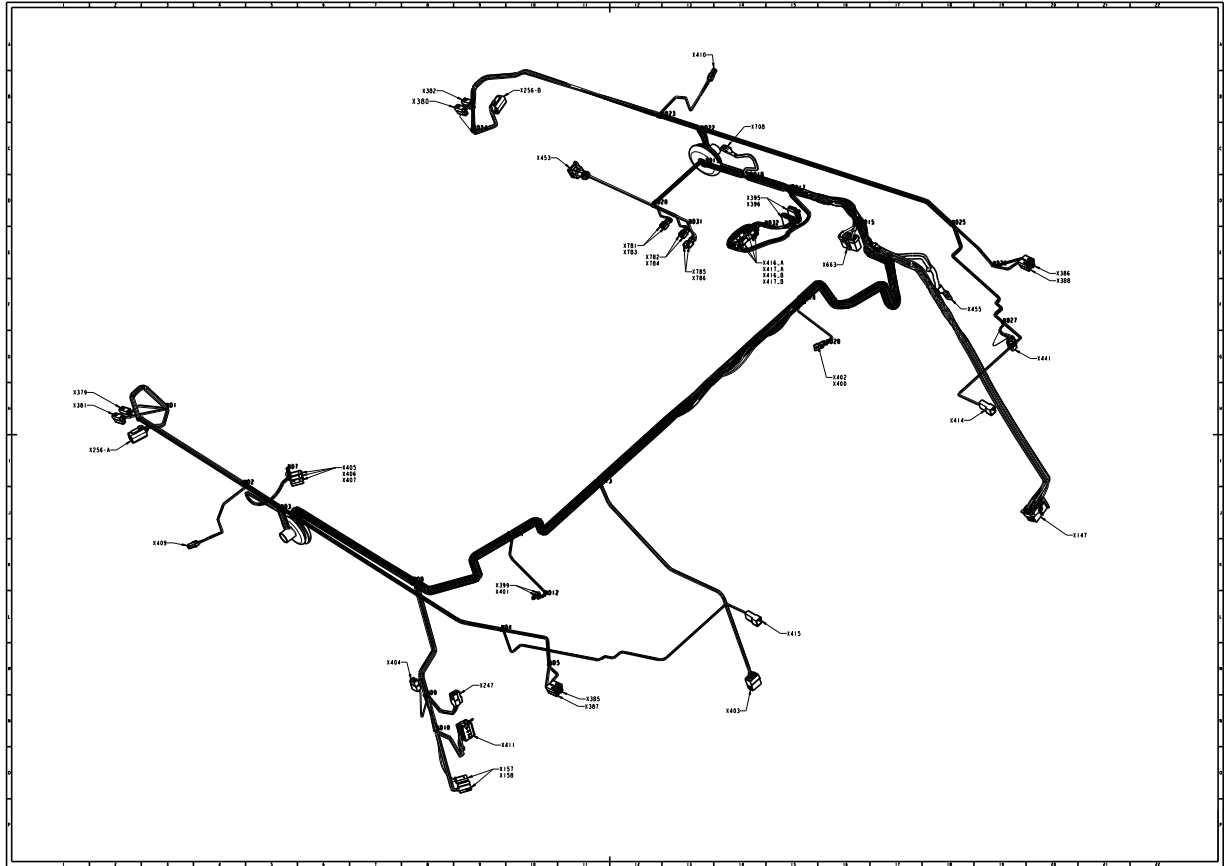
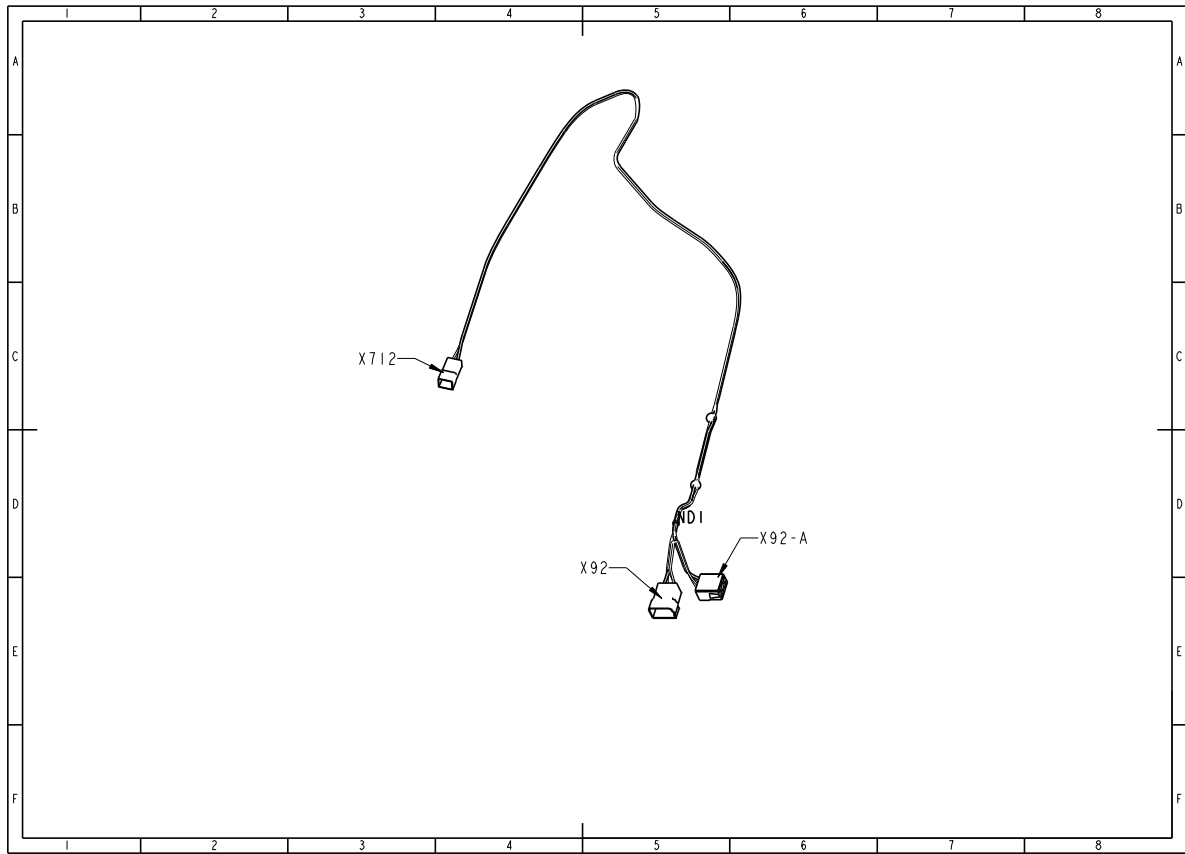

Fig. 231.

FAI223-4375395-402\_40

0036540

### 3.92 FAI228 - Number plate lighting harness - 4357222\_2/2



FAI228 - 4357222/1-4/2\_2/2

Fig. 241.

0033950

**3.102 FAI261 - Isobus harness - 4353133**

X632	
1	•
2	•
3	•
4	•
5	•
6	•

2	W2_CAN_4_H 0.75mm <sup>2</sup> YELLOW
3	W1_CAN_4_L 0.75mm <sup>2</sup> GREEN
4	W2_CAN_4_H 0.75mm <sup>2</sup> YELLOW
5	W1_CAN_4_L 0.75mm <sup>2</sup> GREEN

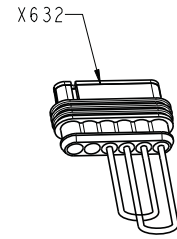

Fig. 261.

F4DF4303133M-01

B045-187

### 3.112 FAI287 - ALO loader harness internal without multi-function armrest - 4378879\_2/2

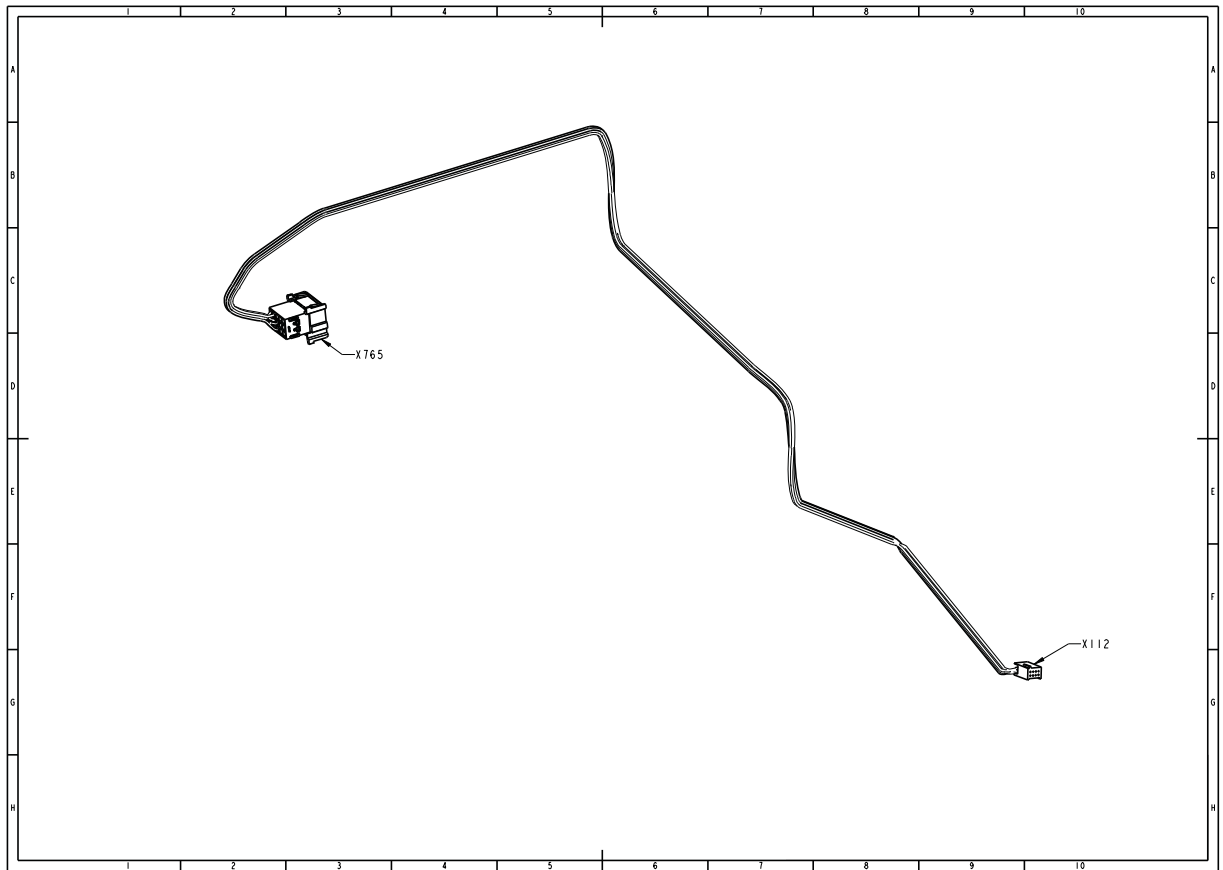

Fig. 281.

FAI287 - 4378879\_2/2\_315

0036603

3.122 FAI294 - Additional heater harness - 4299327\_2/2

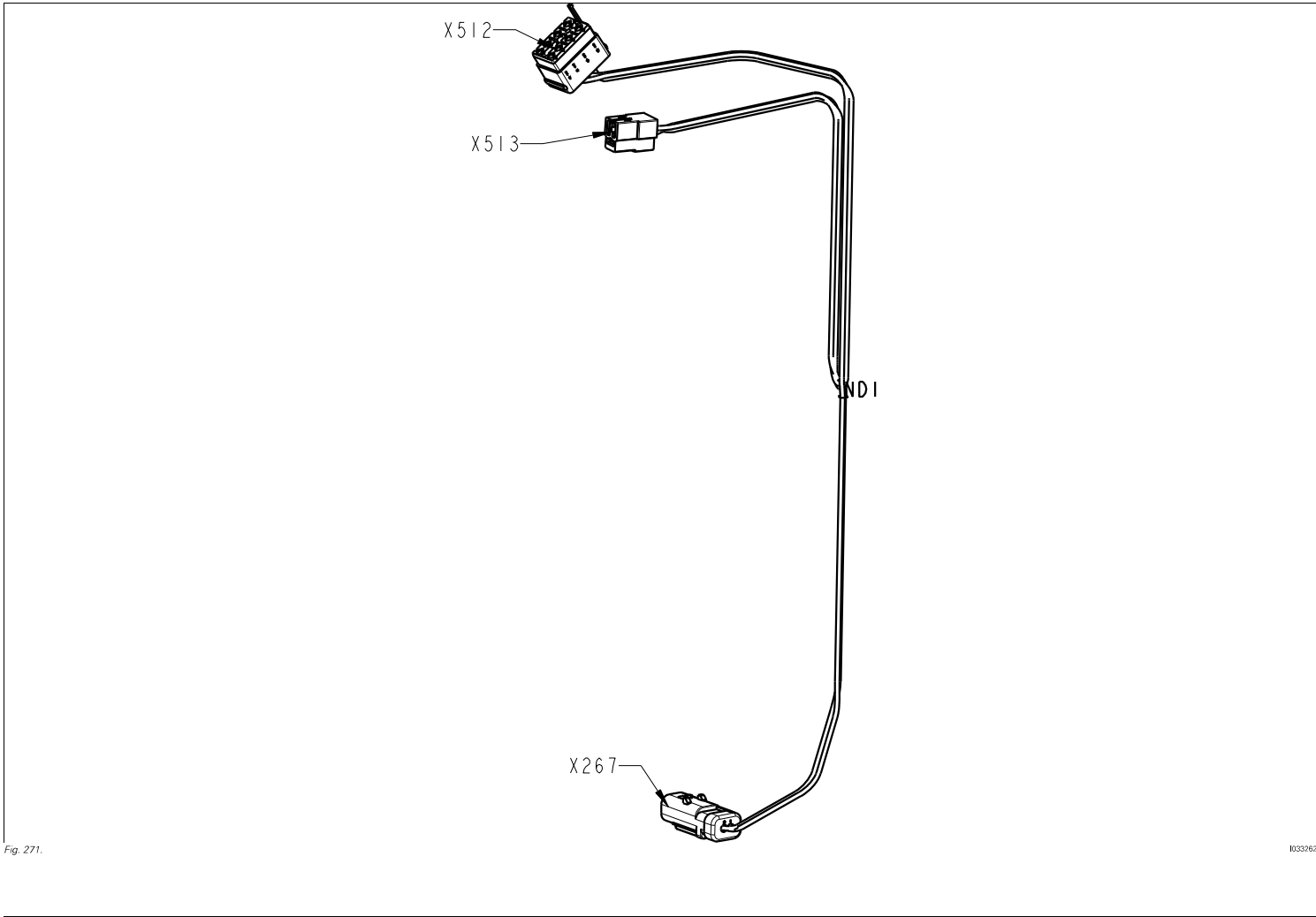
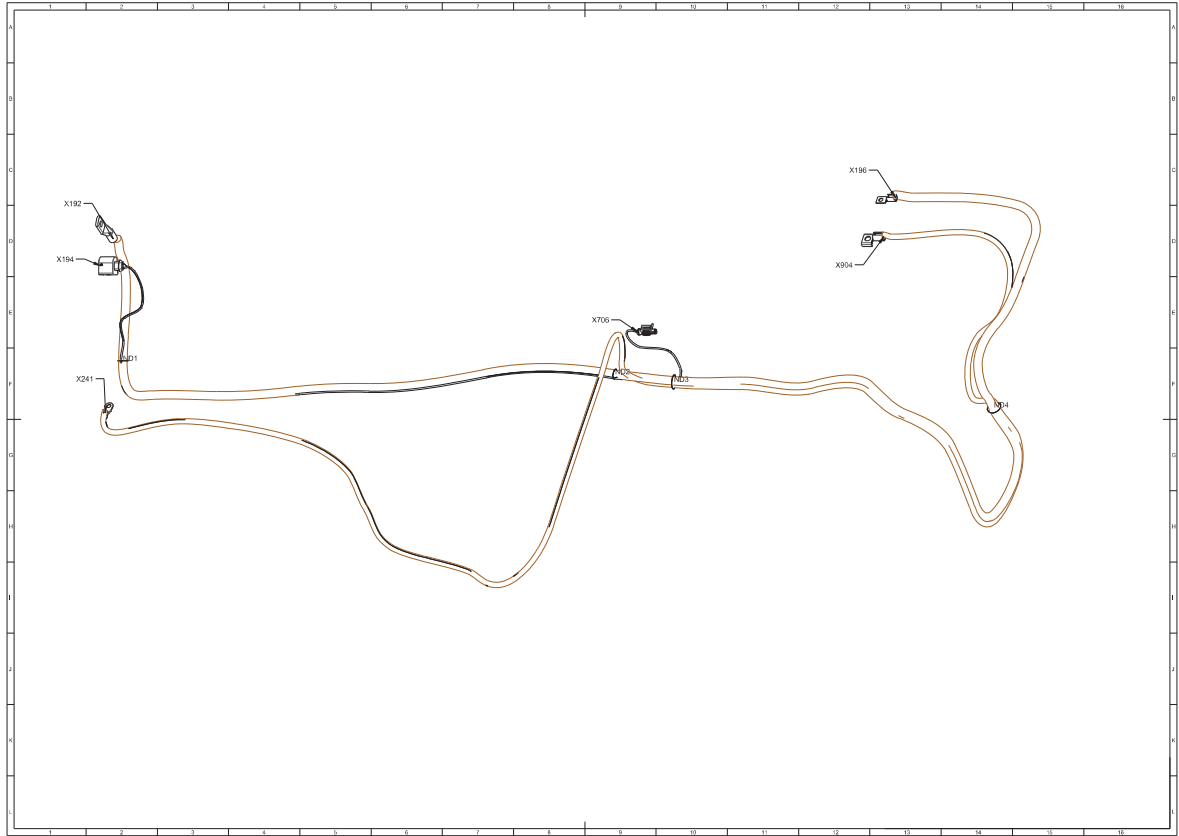

Fig. 271.

003262

### 3.132 FAI314 - Right-hand alternator harness - 4389688\_2/2



FAI314-4389688V2-02\_1/2

Fig. 281.

B045504

**3.142 FAI325 - Power take-off electric selector harness - 3-speed for 5608, 5609 and 5610 tractors - 4377656\_2/2**

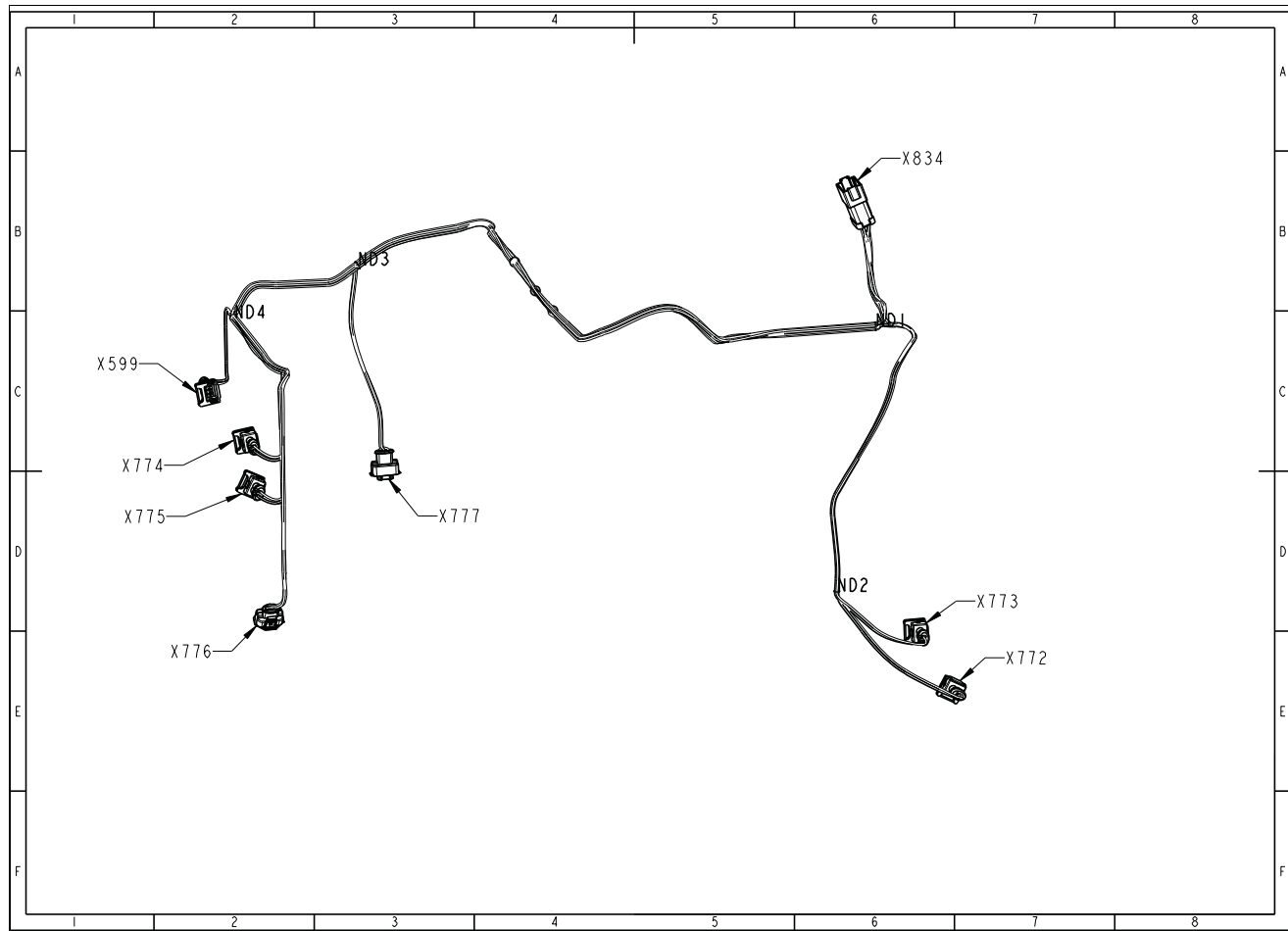
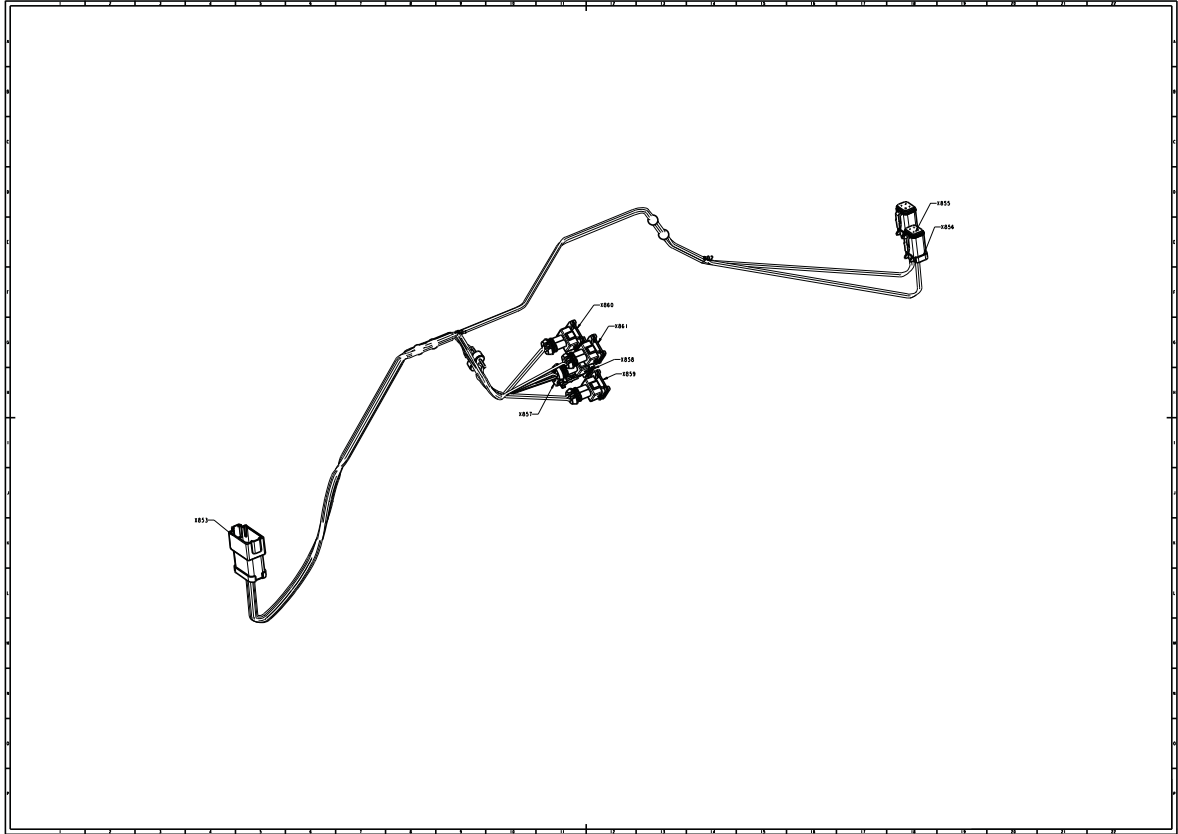

Fig. 291.

FAI325-4377656M2-02\_3/0

B039-104

### 3.152 FAI357 - External Mid Mounted harness - 4353713\_2/2



FAI357-4353713M2-2/2

Fig. 301.

1046037

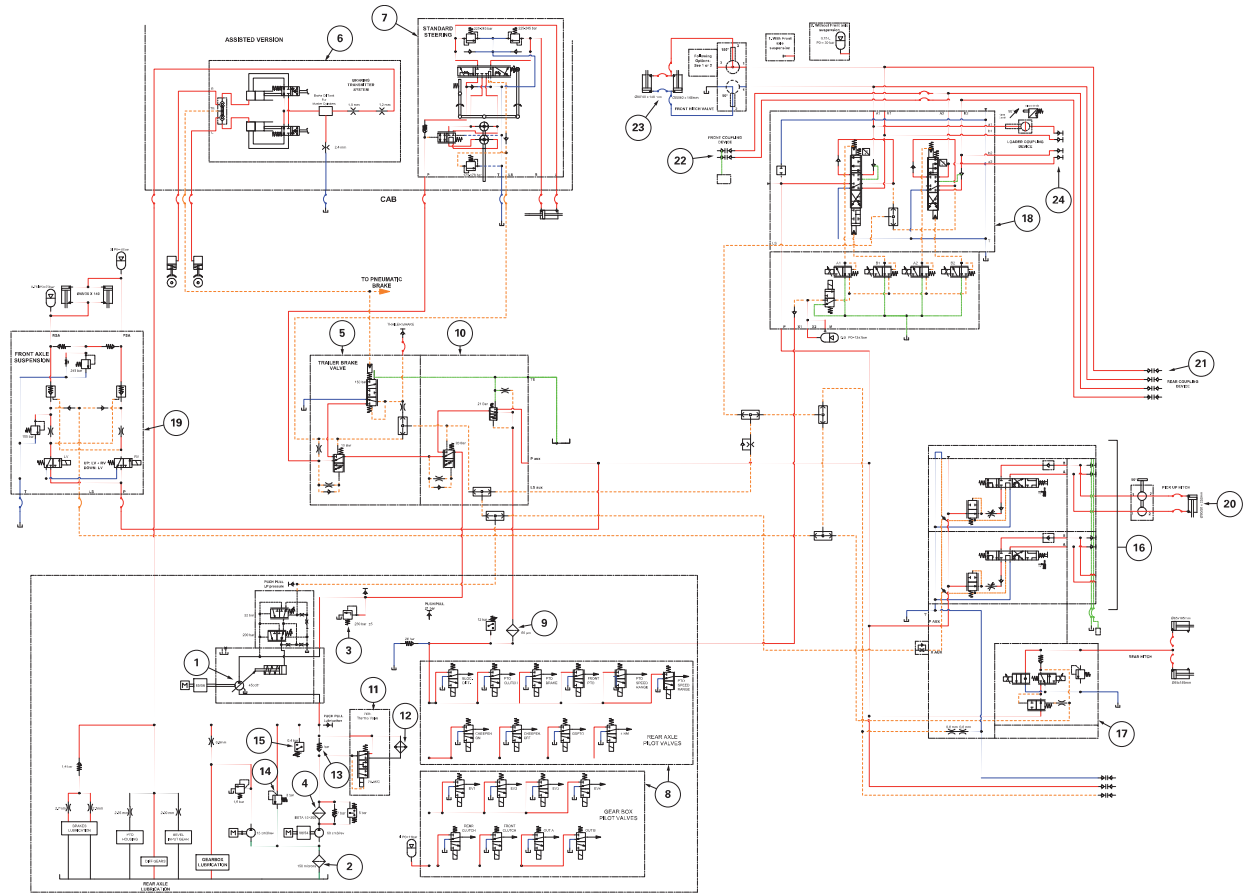

Fig. 3.

1044198

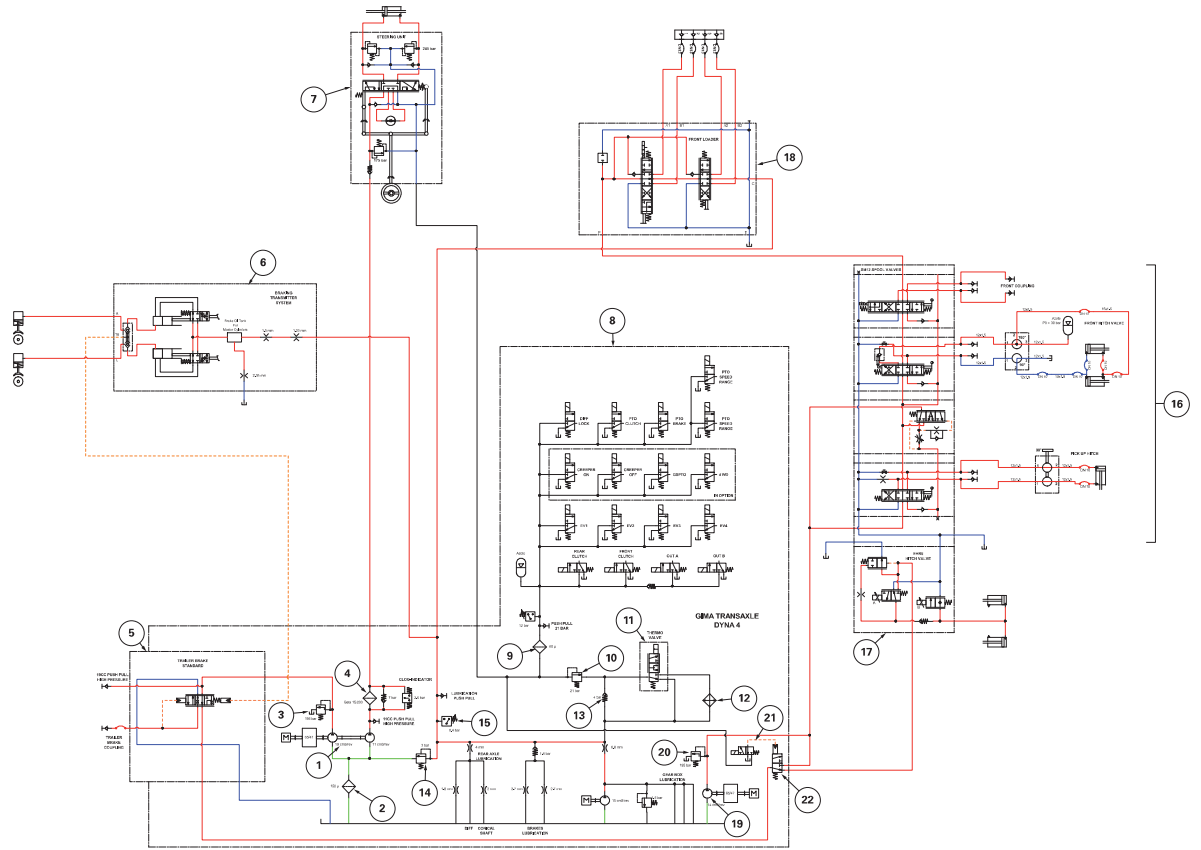

Fig. 8.

1038374

## A - Bleeding

1	Bleeding the main brake system .....	5
2	Bleeding the trailer brake system.....	8
3	Fuel system: bleeding.....	9

# 1 Forward speed calibration

## General

This calibration allows improved precision of forward speed depending on:

- the different tyre sizes available
- radar (if fitted)

## Procedure

1. Mark out a 100 m (328 ft) (depending on the unit of measurement selected) on a firm surface.
2. Start up the tractor, and then press and hold the display selector switch (A) for 15 seconds.

**NOTE:** The daily hourmeter resets to 0 after 5 seconds.

3. "CAL" should appear on the screen [fig. 1](#).
4. Drive the tractor forwards at normal working speed.  
**NOTE:** The tractor must be moving at a constant speed before starting out on the measured course. Otherwise, the calibration is not correct.
5. Press the display selector switch (A) when the starting line of the 100 m (328 ft) course has been passed.

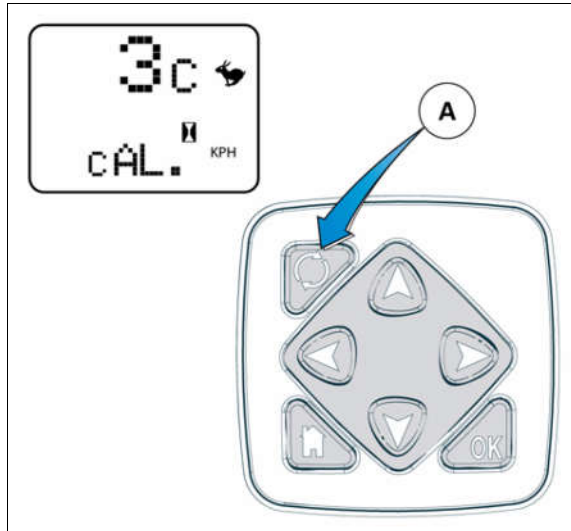

Fig. 1.

1036450

6. "run" should appear on the screen [fig. 2](#).
7. Press the display selector switch (A) when the finish line of the course has been passed.
8. Press the display selector switch (A). The constant forward speed (theoretical) measured during calibration is displayed.
9. Press the display selector switch (A) again. The actual constant forward speed (radar) measured during calibration is displayed on tractors fitted with radar.
10. Press the display selector switch (A) one final time to return the instrument panel to normal operating mode.

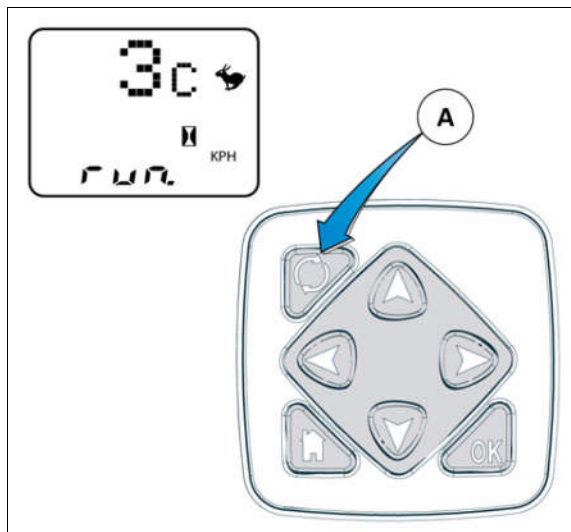

Fig. 2.

1036448

CLICK HERE TO **DOWNLOAD** THE COMPLETE MANUAL

- Thank you very much for reading the preview of the manual.
- You can download the complete manual from: [www.heydownloads.com](http://www.heydownloads.com) by clicking the link below



- Please note: If there is no response to CLICKING the link, please download this PDF first and then click on it.

CLICK HERE TO **DOWNLOAD** THE COMPLETE MANUAL