

# INTRODUCTION

---

## TO THE READER

- This manual is written for an experienced technician to provide technical information needed to maintain and repair this machine.
- Be sure to thoroughly read this manual for correct product information and service procedures.
- If you have any questions or comments, at if you found any errors regarding the contents of this manual, please contact using "Service Manual Revision Request Form" at the end of this manual.  
(Note: Do not tear off the form. Copy it for usage.):  
Publications Marketing & Product Support  
Hitachi Construction Machinery Co. Ltd.  
TEL: 81-298-32-7173  
FAX: 81-298-31-1162

---

## ADDITIONAL REFERENCES

- Please refer to the materials listed below in addition to this manual.
  - The Operator's Manual
  - The Parts Catalog
  - Operation Manual of the Engine
  - Parts Catalog of the Engine
  - Hitachi Training Material

---

## MANUAL COMPOSITION

- This manual consists of three portions: the Technical Manual (Operational Principle), the Technical Manual (Troubleshooting) and the Workshop Manual.
- Information included in the Technical Manual (Operational Principle):  
technical information needed for redelivery and delivery, operation and activation of all devices and systems.
- Information included in the Technical Manual (Troubleshooting):  
technical information needed for operational performance tests, and troubleshooting procedures.
- Information included in the Workshop Manual:  
technical information needed for maintenance and repair of the machine, tools and devices needed for maintenance and repair, maintenance standards, and removal/installation and assemble/disassemble procedures.

---

## PAGE NUMBER

- Each page has a number, located on the center lower part of the page, and each number contains the following information:

Example : T 1-3-5

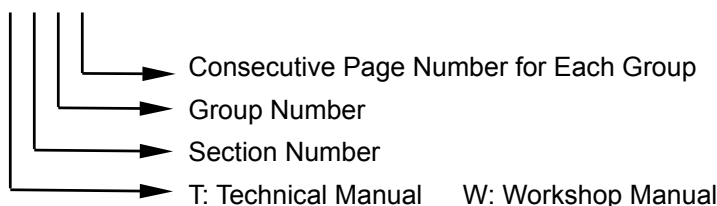

CLICK HERE TO **DOWNLOAD** THE COMPLETE MANUAL

- Thank you very much for reading the preview of the manual.
- You can download the complete manual from: [www.heydownloads.com](http://www.heydownloads.com) by clicking the link below



- Please note: If there is no response to CLICKING the link, please download this PDF first and then click on it.

CLICK HERE TO **DOWNLOAD** THE COMPLETE MANUAL

## SAFETY

---

### KEEP RIDERS OFF MACHINE

- Riders on machine are subject to injury such as being struck by foreign objects and being thrown off the machine.
  - Only the operator should be on the machine. Keep riders off.
  - Riders also obstruct the operator's view, resulting in the machine being operated in an unsafe manner.

014-E01B-0379

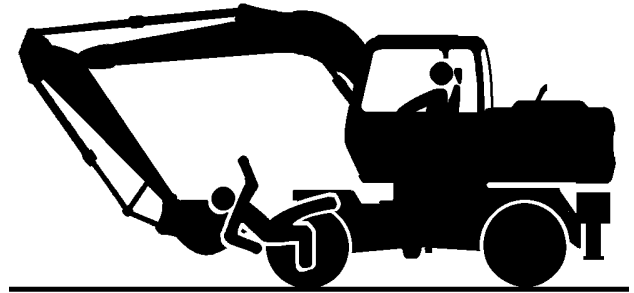

SA-091

---

### PROVIDE SIGNALS FOR FOBS INVOLVING MULTIPLE NUMBERS OF MACHINES

- For jobs involving multiple numbers of machines, provide signals commonly known by all personnel involved. Also, appoint a signal person to coordinate the job site. Make sure that all personnel obey the signal person's directions.

018-E01A-0481



SA-481

---

### CONFIRM DIRECTION OF MACHINE TO BE DRIVEN

- Incorrect steering wheel shift lever operation may result in serious injury death.
  - Before driving the machine, confirm the position of the undercarriage in relation to the operator's position. If the travel motors are located in front of the cab, the machine will move in reverse when travel pedals/levers are operated to the front.

017-E01A-0491

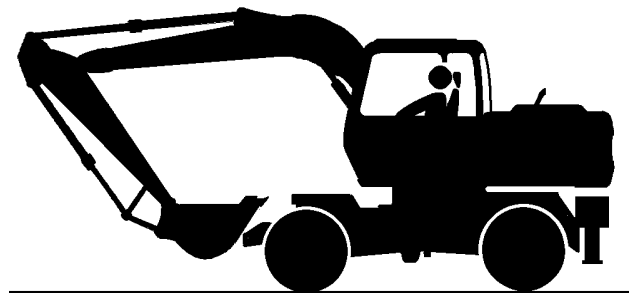

SA-092

## SAFETY

---

- If a maintenance procedure must be performed with the engine running, do not leave machine unattended.
- If the machine must be raised, maintain a 90 to 110 angle between the boom and arm. Securely support any machine elements that must be raised for service work.
- Never work under a machine raised by the boom.
- Inspect certain parts periodically and repair or replace as necessary. Refer to the section discussing that part in the "MAINTENANCE" chapter in the operator's manual.
- Keep all parts in good condition and properly installed.
- Fix damage immediately. Replace worn or broken parts. Remove any buildup of grease, oil, or debris.
- When cleaning parts, always use nonflammable detergent oil. Never use highly flammable oil such as fuel oil and gasoline to clean parts or surfaces.
- Disconnect battery ground cable (-) before making adjustments to electrical systems or before welding on the machine.
- Illuminate your work area adequately but safely.
- Use a portable safety light for working inside or under the machine.
- Make sure that the bulb is enclosed by a wire cage.  
The hot filament of an accidentally broken bulb can ignite spilled fuel or oil.
- Sufficiently illuminate the work site. Use a maintenance work light when working under or inside the machine.
- Always use a work light protected with a guard. In case the light bulb is broken, spilled fuel, oil antifreeze fluid, or window washer fluid may catch fire.

S500-E02B-0497



SA-028



SA-527



SA-037

## SAFETY

---

### SERVICE AIR CONDITIONING SYSTEM SAFELY

- If spilled onto skin, refrigerant may cause a cold contact burn.
  - Refer to the freon container for proper use when servicing the air conditioning system.
  - Use a recovery and recycling system to avoid venting freon into the atmosphere.
  - Never let the freon stream make contact with the skin.



513-E01A-0405

SA-405

### HANDLE CHEMICAL PRODUCTS SAFELY

- Direct exposure to hazardous chemicals can cause serious injury. Potentially hazardous chemicals used with your machine include such items as lubricants, coolants, paints, and adhesives.
  - A Material Safety Data Sheet (MSDS) provides specific details on chemical products: physical and health hazards, safety procedures, and emergency response techniques.
  - Check the MSDS before you start any job using a hazardous chemical. That way you will know exactly what the risks are and how to do the job safely. Then follow procedures and use recommended equipment.

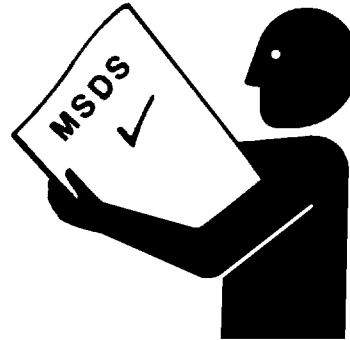

S515-E01A-0309

SA-309

## GENERAL / Precautions for Disassembling and Assembling

### Precautions for Using Nylon Sling

1. Follow the precautions below to use nylon slings safely.
  - Attach protectors (soft material) on the corners of the load so that the nylon sling does not directly contact the corners. This will prevent the nylon sling from being damaged and the lifted load from slipping.
  - Lower the temperature of the lifted load to lower than 100 °C (212 °F). If unavoidably lifting a load with a temperature of 100 °C (212 °F) or more, reduce the load weight.
  - Do not lift acid or alkali chemicals.
  - Take care not to allow the sling to become wet. The load may slip.
  - When required to use more than one sling, use slings with the same width and length to keep the lifted load balanced.
  - When lifting a load using an eyehole, be sure to eliminate any gaps between the sling and load. (Refer to the right illustration.) Reduce the load weight so that it is less than 80 % of the sling breaking force.
  - Avoid using twisted, bound, connected, or hitched slings.
  - Do not place any object on twisted or bent slings. (Refer to the right illustration.)
  - When removing the slings from under the load, take care not to damage the nylon slings. Avoid contact with protrusions.
  - Avoid dragging slings on the ground, throwing slings or pushing slings with a metal object.
  - When using with other types of slings (wire rope) or accessories (shackle), protect the joint so that the nylon sling is not damaged.
  - Store the nylon slings indoors so they won't deteriorate with heat, sun light, or chemicals.

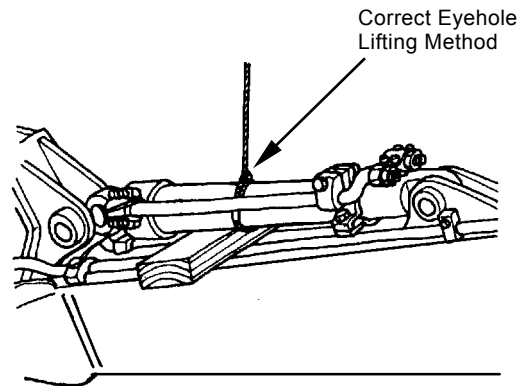

W102-04-02-016

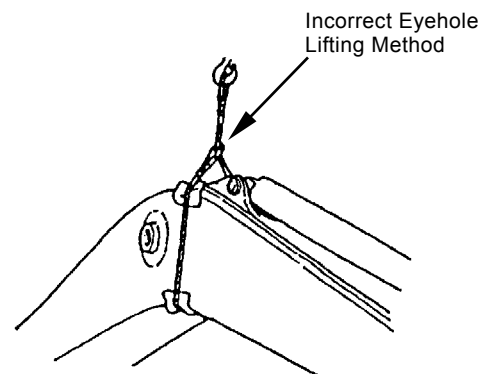

W105-04-01-008

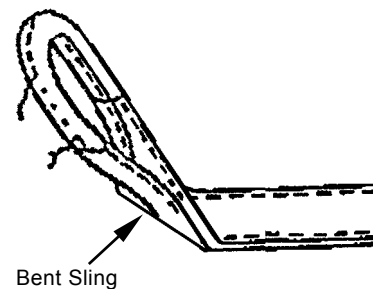

W162-01-01-009

# GENERAL / Tightening

## Screw-In Connection

Depending on types of screw and sealing, different types of screw fittings are used.

**IMPORTANT:** Be sure to confirm that the thread pitch and thread type (tapered or straight) are the correct type before using any screw-in connection.

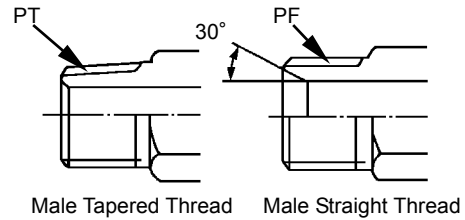

W105-01-01-018

Male Tapered Thread		
Wrench Size mm	Tightening Torque N·m (kgf·m, lbf·ft)	
Hose Fittings	FC material	SS material
19	14.5 (1.5, 10.5)	34 (3.5, 25)
22	29.5 (3.0, 21.5)	49 (5.0, 36)
27	49 (5.0, 36)	93 (9.5, 69)
36	69 (7.0, 51)	157 (16, 116)
41	108 (11, 80)	205 (21, 151)
50	157 (16, 116)	320 (33, 235)
60	195 (20, 144)	

## Seal Tape Application

Seal tape is used to seal clearances between male and female threads, so as to prevent any leaks between threads.

Be sure to apply just enough seal tape to fill up thread clearances. Do not overwrap.

### • Application Procedure

Confirm that the thread surface is clean and, free of dirt or damage.

Apply seal tape around threads as shown. Wrap seal tape in the same direction as the threads.

## Low-Pressure-Hose Clamp Tightening Torque

Low-pressure-hose clamp tightening torque differs depending on the type of clamp.

T-Bolt Type Band Clamp:

4.4 N·m ( 0.45 kgf·m, 3.25 lbf·ft )

Worm Gear Type Band Clamp:

5.9 to 6.9 N·m (0.6 to 0.7 kg·m, 4.3 to 5.1 lbf·ft)

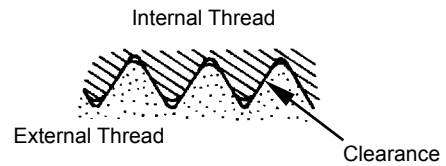

W105-01-01-019

Leave one to two pitch threads uncovered

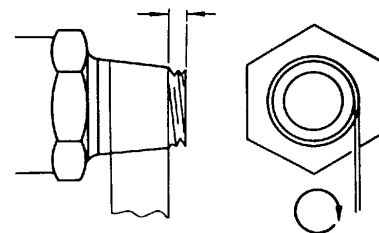

M114-07-041

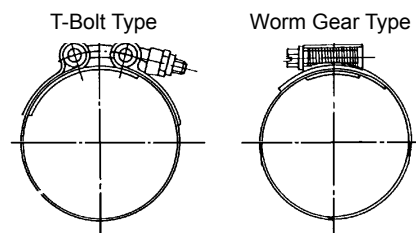

M114-07-043

M114-07-042

---

---

# SECTION 2 UPPERSTRUCTURE

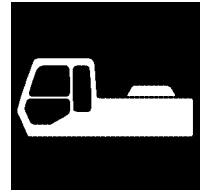

## — CONTENTS —

### Group 1 Cab

- Remove and Install Cab ..... W2-1-1
- Dimensions of the Cab Glass.....W2-1-7

### Group 2 Counterweight

- Remove and Install Counterweight ..... W2-2-1

### Group 3 Main Frame

- Remove and Install Main Frame .....W2-3-1

### Group 4 Pump Device

- Remove and Install Pump Device ..... W2-4-1
- Disassemble Pump Device .....W2-4-4
- Assemble Pump Device .....W2-4-12
- Disassemble Regulator .....W2-4-24
- Assemble Regulator .....W2-4-26
- Disassemble Solenoid Valve .....W2-4-28
- Assemble Solenoid Valve .....W2-4-30
- Disassemble and Assemble
  - Pilot Pump .....W2-4-32
- Maintenance Standard .....W2-4-34

### Group 5 Control Valve

- Remove and Install Control Valve..... W2-5-1
- Disassemble Control Valve
  - (4-Spool Section) ..... W2-5-2
- Disassemble Control Valve
  - (5-Spool Section) ..... W2-5-8
- Disassemble and Assemble
  - 4-Spool and 5-Spool Sections..... W2-5-14
- Assemble Control Valve
  - (4-Spool Section) ..... W2-5-16
- Assemble Control Valve
  - (5-Spool Section) ..... W2-5-24
- Remove and Install
  - Auxiliary Control Valve ..... W2-5-33
- Disassemble Auxiliary Control Valve ... W2-5-34
- Assemble Auxiliary Control Valve ..... W2-5-36

### Group 6 Swing Device

- Remove and Install Swing Device ..... W2-6-1
- Disassemble Swing Reduction Gear ..... W2-6-4
- Assemble Swing Reduction Gear ..... W2-6-10
- Disassemble Swing Motor ..... W2-6-18
- Assemble Swing Motor ..... W2-6-22
- Maintenance Standard ..... W2-6-26

## UPPERSTRUCTURE / Cab

### Remove Cab Glass

Procedures to remove left-hand cab glass, lower glass of the door and upper front glass



**CAUTION:** When removing broken or cracked glass beware of the danger of glass shards that may cause serious injury. Before removing, gummed tape or something like should be used to paste the broken or cracked glass ready to reinforce them so as to prevent hurt from occurring. Be sure to remove glass pieces away. Take protective measures before removing. Reinforce broken or cracked glass with gummed tape to assist in safe removal.

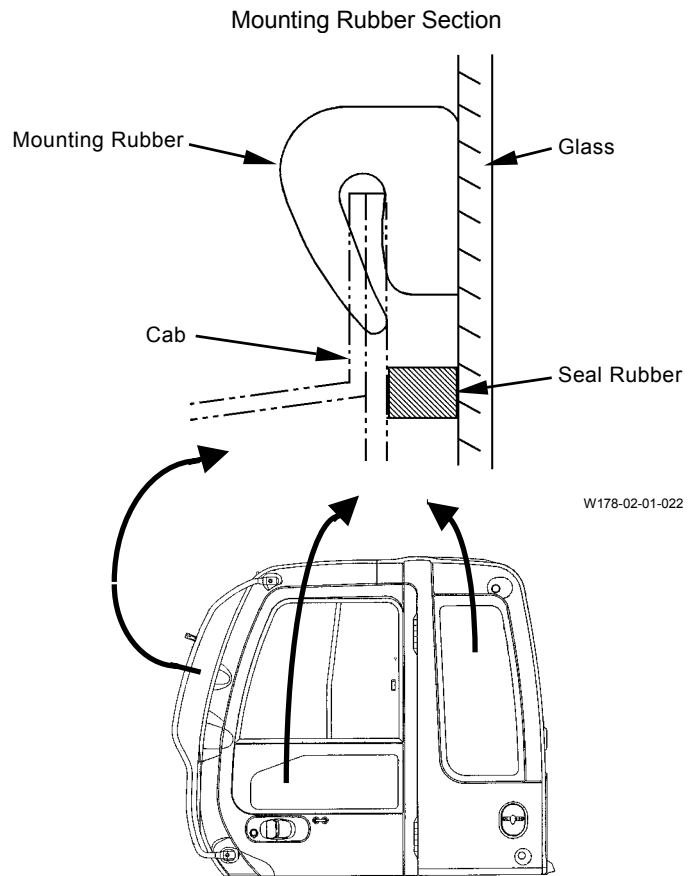

1. Insert bamboo spatula into position A in mounting rubber to pry the mounting rubber apart along all periphery. It is easier to remove glass when air is entered between cab and mounting rubber.
2. Tap glass from the side in cab by palm of the hand to take the glass off. Two men are required to do the work.

**IMPORTANT:** Be sure to install the cab glass and mounting rubber using the special bonding agent. The cab glass may fall if the special bonding agent is not used. The cab glass assembly cannot be replaced individually. Be sure to change the cab glass as an assembly.

The upper front glass is arched-fringed. If this glass needs to be replaced, contact with the nearest HITACHI dealers to replace it as an assembly.

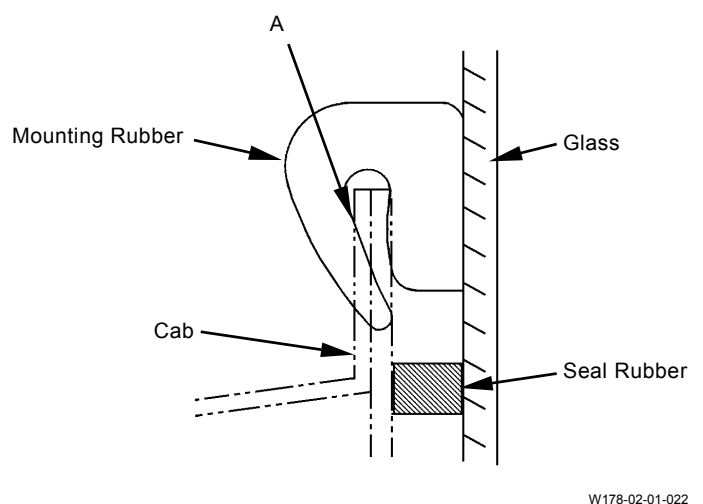

## UPPERSTRUCTURE / Pump Device

### REMOVE AND INSTALL PUMP DEVICE

**CAUTION:** Be sure to bleed air from hydraulic oil tank before starting the work.  
(Refer to “Bleeding Air from Hydraulic Oil Tank” on page W1-4-1.)

#### Removal

1. Remove bolts (2) (3 used) to remove bracket (1) and engine cover (3).
2. Disconnect connectors (7 places).

**CAUTION:** Pump device weight: 170 kg (375 lb)

**IMPORTANT:** Attach the identification tag onto the disconnected hoses for re-assembly.

3. Disconnect main hoses (8) (2 used) and hoses (7) (2 used) from pump device (5). Cap open ends.  
┌ : 8 mm, 10 mm
4. Disconnect suction pipe (6) from pump device (5).  
┌ : 10 mm
5. Disconnect suction hoses (9) (2 used) and pilot hoses (10) (6 used) from pump device (5).  
┌ : 17 mm, 19 mm  
┌ : 10 mm
6. Disconnect the hoses (2 used) below the gear pumps.  
┌ : 27 mm
7. Remove plate (4) between the engine room and pump device (5) room.  
┌ : 17 mm, 19 mm

**IMPORTANT:** Do not install the eyebolt to the regulator, which is with solenoid valves (pump 2 side).

8. Attach eyebolts (M12, Pitch 1.75 mm) (ST 0002) to pump device (5). Lift and hold pump device (5).
9. Remove the pump device (5) mounting bolts (8 used) then lift pump device (5) off.  
┌ : 17 mm

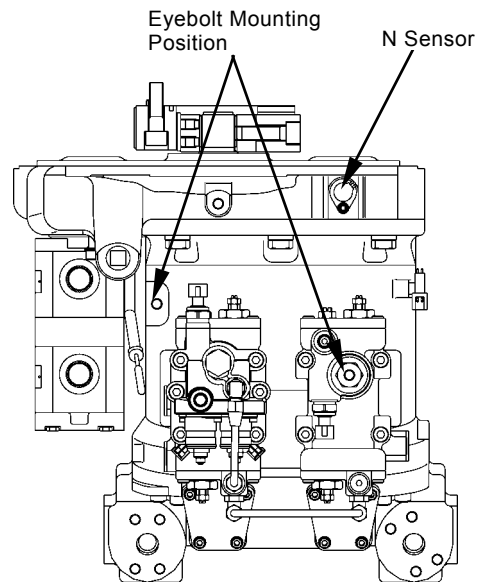
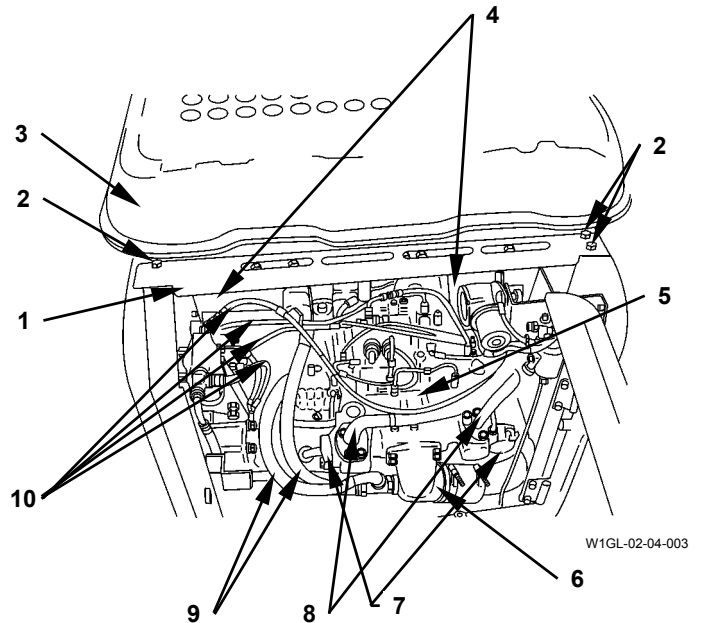

## UPPERSTRUCTURE / Pump Device

23. Remove stopper (24) from pump casing (51).

**CAUTION:** Pump casing weight: 70 kg (154 lb)

24. Lift pump device (51) and place the pump casing on the wooden blocks with mission side facing down. Wooden block size: 100 mm or more in width and height.

25. Remove shafts (13, 19) from pump casing (51) using special tool (ST 1470) (ST 1471). At this time, bearings (10, 12) are removed with the shafts.

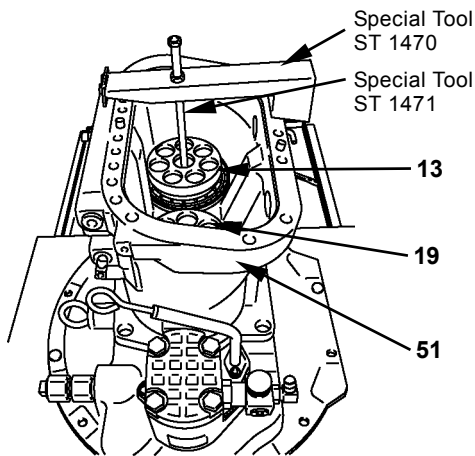

W178-02-04-054

26. Remove slide ring (20) from shaft (19).

27. Remove bearing nut (9) from shafts (13, 19) using special tool (ST 3058).

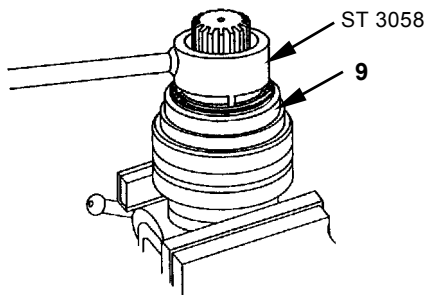

W137-02-04-023

28. Remove bearings (10, 12) as well as ring (11) from shafts (13, 19) with a press.

**CAUTION:** Pump casing weight: 42 kg (93 lb)

29. Lift pump casing (51), and position the regulator with the mounting surface facing up.

30. Remove retaining rings (50) (2 used), oil seals (49) (2 used) from pump casing (51).

31. Remove retaining ring (40) from gear casing (47) and remove retaining ring (41) from gear shaft (44).

32. Pull out upper ball bearing (42) and gear shaft (44) from gear casing (47) using special tool (ST 1393).

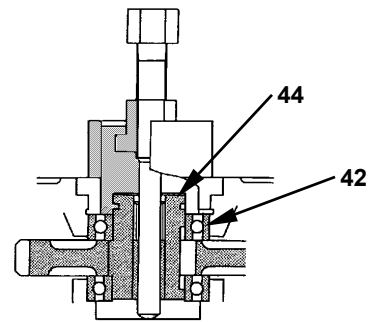

W178-02-04-009

33. Remove gear (43) and ball bearing (42) from gear casing (47).

34. Install a shackle to the bolt hole on the periphery of gear casing (47), lift and turn gear casing (47) over.

35. Remove retaining ring (45), oil seal (46) from gear casing (47).

## UPPERSTRUCTURE / Pump Device

34. Install springs (16) (2 used) to center shafts (15) (2 used).

35. Insert center shafts (15) (2 used) and plungers (17) (14 used) into rotors (18) (2 used).

36. Insert a file's shank etc. into the center hole of center shaft (15), rotate the center shaft to install pin (14) into the groove of rotor (18). (Both right and left pump)

 **NOTE:** If the pin does not enter into the groove of the rotor, selector head (66) cannot be assembled to pump casing (51).

37. Apply a film of LOCTITE LI829 to the threads of pins (61) (4 used), and then install the pins to valve plates (62, right) and (77, left).

 : 7 mm

 : 9.8 N·m (1 kgf·m, 7.2 lbf·ft)

**IMPORTANT:** Take care to the mounting direction of right regulator (62).

38. Insert pins (61) (2 used) for right valve plate (62) into the hole of levers (60) (2 used) for right regulator (2), and install retaining rings (58) (2 used).

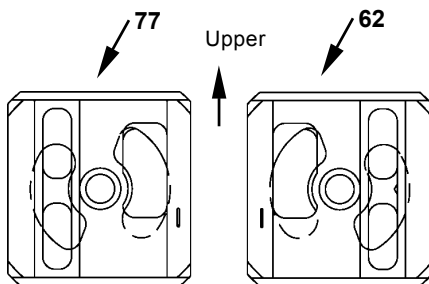

W178-02-04-014

**IMPORTANT:** Take care to the mounting direction of left regulator (77).

39. Insert pins (61) (2 used) for left valve plate (77) into the hole of levers (60) (2 used) for left regulator (6), and install retaining rings (58) (2 used).

40. Install O-rings (56) (2 used), (55) (10 used), (7) (4 used) and spring pins (54) (2 used) into pump casing (51).

41. Install right regulator (2) into pump casing (51), according to the following procedure.

- Adjust the sleeve position so that the grooves in both sleeves on the right regulator are in a line.
- Put the right regulator on the pump casing, install pin (59) for link (79) into the both grooves in the sleeve.
- Move the right regulator, so that spring pin (54) extended from the pump casing can enter into the right regulator.
- Install the right regulator into the pump casing with socket bolts (1) (4 used).

 : 8 mm

 : 49 N·m (5 kgf·m, 36 lbf·ft)

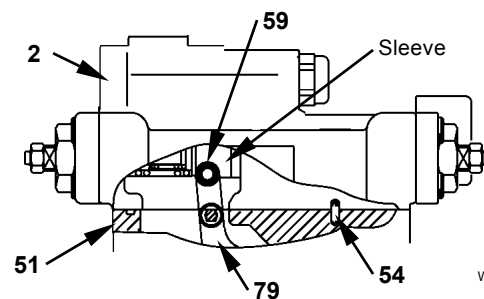

W178-02-04-015

42. Install left regulator (6) onto pump casing (51) in the same procedure as step 41, and secure the left regulator with socket bolts (3, 5) (2 used each).

 : 8 mm

 : 49 N·m (5 kgf·m, 36 lbf·ft)

43. Install backup ring (63), O-ring (64) and O-rings (8) (6 used) into pump casing (51).

44. Insert servo pistons (73) (2 used) into selector head (66).

45. Install pin (74) into servo piston (73), fix the servo piston with set screw (72). (Both right and left servo pistons)

Beforehand, apply a film of LOCTITE LI829 to the threads of the set screw.



 : 6 mm

 : 34.3 N·m (3.5 kgf·m, 25 lbf·ft)

## UPPERSTRUCTURE / Pump Device

### Assemble Solenoid Valve

1. Install filters (16, 20) onto body (17).

 : 6 mm  
 :  $10^{+3}_{-0}$  N·m ( $1^{+0.3}_{-0}$  kgf·m,  $7.2^{+2.2}_{-0}$  lbf·ft)

2. Install wave washer (15) and plate (14) on body (17).

 **NOTE:** When body (17) is horizontally inserted, apply a film of grease to wave washer (15) and plate (14) to prevent them from coming off.  
After assembling, check for straight position of plate (14).

3. Install O-rings (8, 9, 10) to sleeve (11).

4. Insert spool (12) into sleeve (11), then install spring (7), retaining ring (6) and diaphragm (5) on spool (12).

 **NOTE:** Install and let diaphragm (5) crimp towards out.  
After installing, check that spool (12) moves smoothly.

**IMPORTANT:** When installing sleeve (11), keep the sleeve end and body (17) end in the same position.  
In addition, when installing the sleeve, be sure not to pry and cause damage to O-ring.

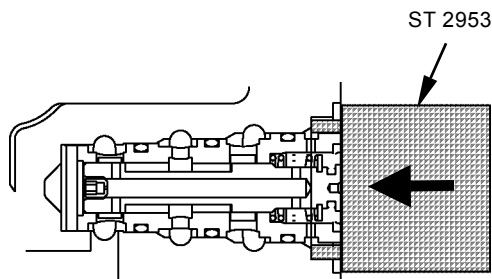

5. Using special tool (ST 2953), install sleeve (11) assembly to body (17).

 **NOTE:** When there is no special tool (ST 2953) available, tighten solenoid (2) alternately with socket bolts (1) (2 used). Then sleeve (11) end and body (17) end should be placed in the same position. Install the solenoid.



W178-02-04-052

6. Install solenoid (2) to body (17) with socket bolt (1) (2 used).

 : 4 mm  
 :  $5^{+2}_{-0}$  N·m ( $0.5^{+0.2}_{-0}$  kgf·m,  $3.6^{+1.4}_{-0}$  lbf·ft)

## UPPERSTRUCTURE / Control Valve

---

- Disassemble travel spool

13. Clamp spool (8) with wooden pieces in a vise. Remove bolt (56), spring seat (57), spring (58), and spring seat (59).

 : 8 mm

- Disassemble bucket spool

14. Clamp spool (9) with wooden pieces in a vise. Remove bolt (60), spring seat (61), spring (62) and spring seat (63).

 : 8 mm

15. Heat the plug (64) part of spool (9) with a drier to melt LOCTITE. Remove plug (64) using special tool (ST 5909).

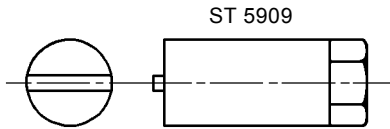

W157-02-05-049

16. Remove sleeve (67), spring (68) and poppet (69) from spool (9).

17. Turn over spool (9) and clamp it in a vise. Heat the plug (74) part of spool (9) with a drier to melt LOCTITE. Remove plug (74) using special tool (ST 5909).

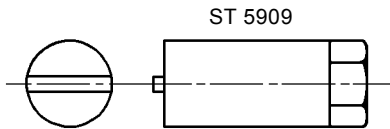

W157-02-05-049

18. Remove spring (71) and poppet (70) from spool (9).

- Disassemble boom 1 spool

19. Clamp spool (10) with wooden pieces in a vise. Remove bolt (75), spring seat (76), spring (77) and spring seat (78).

 : 8 mm

20. Heat the plug (79) part of spool (10) with a drier to melt LOCTITE. Remove plug (79) using special tool (ST 5909).

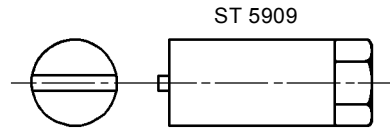

W157-02-05-049

21. Turn over spool (10) and clamp it in a vise. Heat the plug (86) part of spool (10) with a drier to melt LOCTITE. Remove plug (86) using special tool (ST 5909).

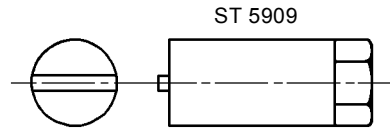

W157-02-05-049

22. Remove spring (83) and poppet (82) from spool (10).

- Disassemble arm 2 spool

23. Clamp spool (11) with wooden pieces in a vise. Remove bolt (87), spring seats (88, 89), springs (90, 91), and spring seats (92, 93).

 : 8 mm

## UPPERSTRUCTURE / Control Valve

---

- Be sure to read "Precautions for Disassembly and Assembly" thoroughly on page W1-1-1 before starting the disassembly work.

### Disassemble

1. Remove socket bolts (283, 292) from housing (1) to remove flanges (284, 293), O-rings (285, 294), springs (286, 295) and poppet (287, 296).

 : 8 mm

2. Remove plug (288), O-ring (289), spring (290) and poppet (291) from housing (1).

 : 6 mm

3. Remove socket bolts (321, 326) from housing (145) to remove flanges (322, 327), O-rings (323, 328), springs (324, 329) and poppets (325, 330).

 : 8 mm



**CAUTION: Housing (1) weight: 75 kg (165 lb)  
Housing (145) weight: 74 kg (163 lb)**

4. Remove socket bolt (331), and separate housing (1) and housing (145).

 : 14 mm

5. Remove O-rings (297 to 320) from the mounting surface of the housing.

### Assemble

1. Install O-rings (297 to 320) onto the mounting surface of the housing.



**CAUTION: Housing (1) weight: 75 kg (165 lb)  
Housing (145) weight: 74 kg (163 lb)**

2. Connect housing (1) and housing (145) with socket bolt (331).

 : 14 mm

 : 167 to 177 N·m  
(17 to 18 kgf·m, 123 to 130 lbf·ft)

3. Install poppets (325, 330), springs (324, 329), O-rings (323, 328), flanges (322, 327) and socket bolts (321, 326) into housing (145).

 : 8 mm

 : 61±3 N·m  
(6.3±0.3 kgf·m, 45.6±2.2 lbf·ft)

4. Install poppet (291), spring (290), O-ring (289) and plug (288) into housing (1).

 : 6 mm

 : 76±3 N·m  
(7.8±0.3 kgf·m, 56.4±2.2 lbf·ft)













5. Install poppets (287, 296), springs (286, 295), O-rings (285, 294), flanges (284, 293) and socket bolts (283, 292) into housing (1).

 : 8 mm

 : 61±3 N·m  
(6.3±0.3 kgf·m, 45.6±2.2 lbf·ft)

## UPPERSTRUCTURE / Control Valve

---

- Be sure to read “Precautions for Disassembly and Assembly” thoroughly on page W1-1-1 before starting the assembly work.
1. Install poppet (273), spring (272), plug (271), spring (270) and sleeve (269) into poppet (274).
  2. Install spool (263), spring (262) and spring seat (261) onto body (264). Temporarily tighten plug (259).  
 : 36 mm
  3. Install the poppet (274) assembly into housing (145). Install body (264) with socket bolt (265).  
 : 8 mm  
 : 61±3 N·m (6.3±0.3 kgf·m, 45.6±2.2 lbf·ft)
  4. Completely tighten plug (259), which was temporarily tightened in step 2.  
 : 36 mm  
 : 98 N·m (10 kgf·m, 72 lbf·ft)
  5. Install poppet (248), spring (247), plug (246), spring (245) and sleeve (244) into poppet (249).
  6. Install spool (238), spring (237) and spring seat (236) into body (239), then temporarily tighten plug (234).  
 : 36 mm
  7. Install the poppet (249) assembly into housing (145). Install body (239) with socket bolt (240).  
 : 8 mm  
 : 61±3 N·m (6.3±0.3 kgf·m, 45.6±2.2 lbf·ft)
  8. Completely plug (234) which was temporarily tightened in step 6.  
 : 36 mm  
 : 98 N·m (10 kgf·m, 72 lbf·ft)
  9. Install poppet (226), spring (225), O-ring (224), flange (223) and socket bolt (222) into housing (145).  
 : 8 mm  
 : 61±3 N·m (6.3±0.3 kgf·m, 45.6±2.2 lbf·ft)

## UPPERSTRUCTURE / Control Valve

---

### Disassemble Auxiliary Control Valve

- Be sure to read "Precautions for Disassembly and Assembly" thoroughly on page W1-1-1 before starting any repair work.

1. Loosen socket bolts (45) (2 used), (48), and (49) to remove covers (46, 50) and O-rings (47, 56).

 : 6 mm

**IMPORTANT: Remove the spool (57) assembly (51 to 59) while carefully moving them. If they stick, even a little, try it again instead of pulling roughly.**

2. Remove spool (57) assembly (51 to 59) from housing (62).

3. Secure spool (57) with wooden pieces in a vice. Remove end spool (51), seat (52), springs (53, 54) and seat (55).

 : 8 mm

**IMPORTANT: As the set pressure may be changed, be sure not to disassemble overload relief valve assemblies (1 to 18) and (19 to 36).**

4. Remove overload relief valve assembly (1 to 18) and (19 to 36) from housing (62).

 : 32 mm

 **NOTE:** As each set pressure is different, be sure to install overload relief valve assemblies (1 to 18) and (19 to 36) correctly.

5. Remove sleeve (41) assembly (37 to 42) from housing (62).

 : 36 mm

6. Pull out spring (43) and poppet (44) from housing (62).

7. Secure seat (37) in a vice. Remove sleeve (41), spring (40), valve (39), and O-rings (38, 42).

 : 36 mm

 **NOTE:** As plate (61) is installed with drive screw (60), be sure not to disassemble the plate.

## UPPERSTRUCTURE / Swing Device

**IMPORTANT:** The hole for the spring pin located on the 1st stage carrier is not a through one. Take care to the tapping-in distance when tapping the spring pin in.

13. Tap spring pin (5) on the 1st stage carrier (21) assembly into pin (4) using special tool (ST 1462). Stop tapping when the spring pin is driven to the middle of the pin hole. Do not try to tap spring pin (5) to the end.
14. Remove pin (4), planetary gear (7), needle bearing (6), thrust plate (8) from 1st stage carrier (21).
15. Remove remaining two sets of pin (4), planetary gear (7), needle bearing (6), thrust plate (8) from 1st stage carrier (21) according to the removing procedure in step 13 and step 14.
16. Remove thrust plate (3) from 1st stage carrier (21).

**IMPORTANT:** The surface of the pin except for both ends is a rotating surface for the needle bearing.  
**Take care not to damage it.**

17. Clamp the pin (4) with a vise. Push the spring pin out using special removing tool (ST 1462). (3 places)
18. Disassemble the 2nd stage carrier (18) assembly according to the removing procedure for the 1st stage carrier (21) assembly. However 6 needle bearings (12) and 6 thrust plates (11) are used on the 2nd stage carrier (18) assembly. Moreover, use ST 1463 as the extractor for spring pin (10).
19. Remove bolt (17) to remove lock plate (16).  
🔧 : 17 mm

20. Remove bearing nut (15) from shaft (30) using special nut removing tool (ST 2926).

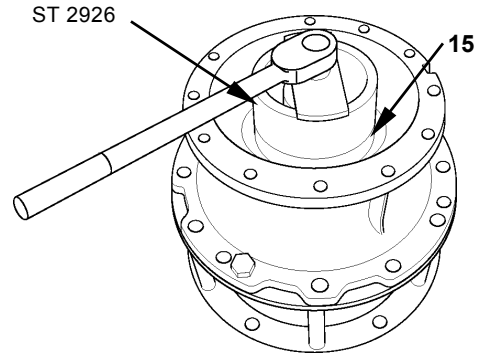

W178-02-06-008



**CAUTION: Housing (25) assembly weight: 110 kg (240 lb)**

21. Install eyebolt (M16) into bolt (23) hole in housing (25). Lift housing (25). Remove bracket (ST 5097), which has been installed at the pinion gear side.  
🔧 : 30 mm
22. After removing bracket (ST 5097), install bracket (ST 1464). Install the housing (25) assembly on a press.  
🔧 : 30 mm

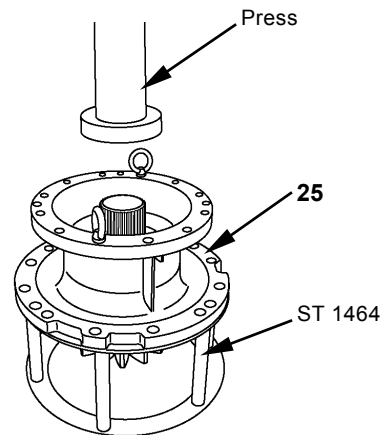

W178-02-06-006

## UPPERSTRUCTURE / Swing Device

**IMPORTANT: Take care to the mounting direction of the 2nd stage carrier.**

24. Install the 2nd stage carrier (18) assembly onto the spline of shaft (30), while the concave part of the boss in bottom side of the carrier comes in contact with lock plate (16).

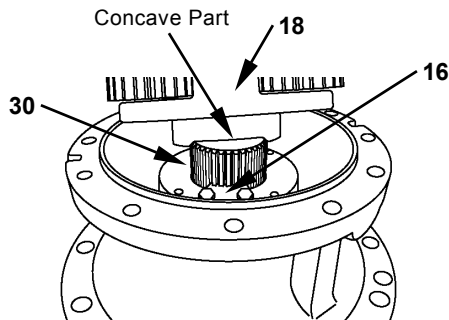

W178-02-06-014

25. Install 2nd stage sun gear (20) into the 2nd stage carrier (18) assembly with the small diameter part of the 2nd stage sun gear facing up.

26. Clean off old THREEBOND and apply new THREEBOND #1215 onto the mounting surface of ring gear (24) inside of housing (25).

27. Install eyebolt (M12) to the motor mounting threaded hole on ring gear (24). Lift the ring gear off, install the ring gear on housing (25) with socket bolts (23) (12 used) while aligning the mating marks.

 : 10 mm

28. Install the 1st stage carrier (21) assembly onto the spline of 2nd stage sun gear (20).

**IMPORTANT: Take care to the mounting direction of the sun gear.**

29. Install 1st stage sun gear (2) into the 1st stage carrier (21) assembly with the stepped side of the sun gear facing down.

30. Install pipe (32) into housing (25) with seal tape wound on the threaded part of the pipe.

 : 18 mm

31. Wind seal tape on drain plug (31), then install drain plug (31) into pipe (32).

 : 8 mm

 : 50 N·m (5 kgf·m, 36 lbf·ft)

32. Fill gear oil into ring gear (24) until the middle part of the 1st stage sun gear (2) is submerged. (Approx. 6.5 L (1.72 US gal.))

33. Clean off the old THREEBOND, then apply new THREEBOND #1212 onto the motor (1) mounting surface of ring gear (24).



**CAUTION: Motor weight: 47 kg (100 lb)**

34. Install eyebolt (M10) to motor (1) and lift motor (1) off. Align the mating marks, and then fasten the swing motor and ring gear (24) with bolts (22) (8 used).

 : 10 mm

 : 88 N·m (9 kgf·m, 65 lbf·ft)

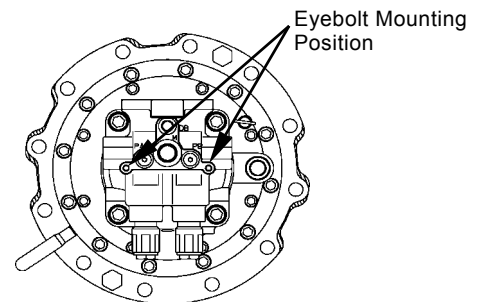

W178-02-06-005

## UPPERSTRUCTURE / Swing Device

### 3. Thickness of shoe

Unit: mm (in)

Standard	Allowable Limit
5.5 (0.22)	5.3 (0.21)

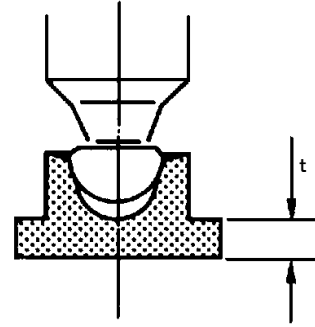

W107-02-06-142

### 4. Thickness of friction plate

Unit: mm (in)

Standard	Allowable Limit
2.0 (0.08)	1.8 (0.07)

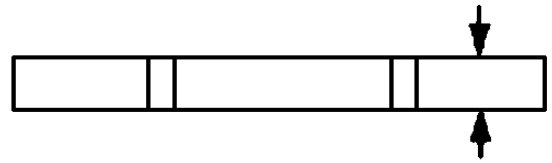

W107-02-06-143

## UPPERSTRUCTURE / Pilot Valve

---

**IMPORTANT:** Do not remove the spool (13) assembly unless necessary.

**IMPORTANT:** When removing spool (13) from spring seats (9) (4 used), push the spool in the spring seat, then direct it towards the bigger hole while remove it. However, do not push the spring seat in more than 6 mm (0.24 in).

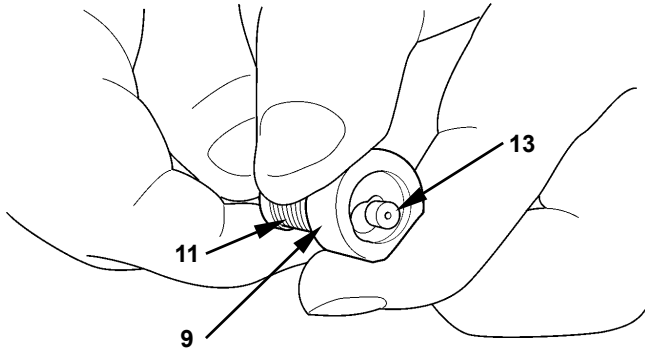

W577-02-06-004

7. Remove spring seats (9) (4 used), springs (11) (4 used) and washers (12) (4 used) from spool (13).
8. Clamp the pilot valve on a vise and secure the pilot valve with the port plate (18) facing upward.
9. Remove socket bolts (20) (2 used) from casing (14).  
 : 6 mm
10. Remove port plate (18), O-ring (15) and bushing (16) from casing (14).

## UPPERSTRUCTURE / Pilot Shut-Off Valve

### REMOVE AND INSTALL PILOT SHUT-OFF VALVE



**CAUTION:** Be sure to bleed air from hydraulic oil tank before starting the work.  
(Refer to “Bleeding Air from Hydraulic Oil Tank” on page W1-4-1.)

#### Removal

1. Remove spring (3).

**IMPORTANT:** Attach identification tags to disconnected hoses for re-assembly.

2. Disconnect hoses (6 to 13) and pipes (14, 15).

 : 17 mm, 19 mm, 22 mm

3. Remove spring pin (5) then remove lever (1).

4. Remove bolts (2) (2 used) and remove pilot shut-off valve (4).

 : 17 mm

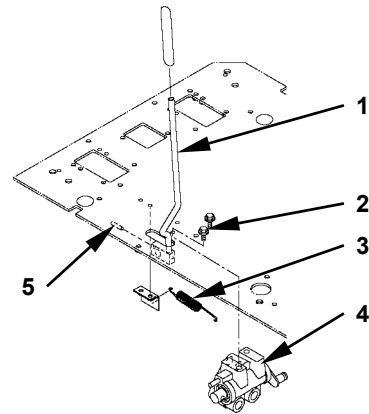

W178-02-08-001

#### Installation

1. Install pilot shut-off valve (4) with bolts (2) (2 used).

 : 17 mm

 : 50 N·m (5.1 kgf·m, 37 lbf·ft)

2. Install lever (1) with spring pin (5).

3. Connect hoses (6 to 13) and pipes (14, 15).

 : 17 mm

 : 24.5 N·m (2.5 kgf·m, 18 lbf·ft)

 : 19 mm

 : 29.5 N·m (3.0 kgf·m, 21.5 lbf·ft)

 : 22 mm

 : 39 N·m (4.0 kgf·m, 28.5 lbf·ft)

4. Install spring (5).

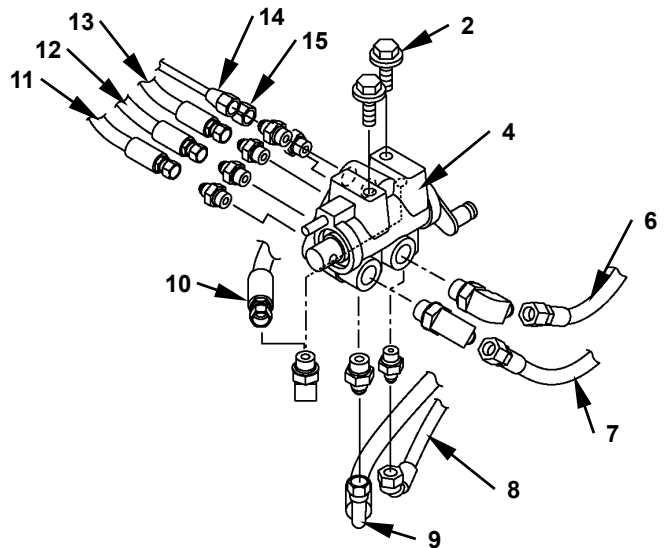

W178-02-08-002

## UPPERSTRUCTURE / Travel Shockless Valve

### REMOVE AND INSTALL TRAVEL SHOCKLESS VALVE



**CAUTION:** Be sure to bleed air from hydraulic oil tank before starting the work.  
(Refer to “Bleeding Air from Hydraulic Oil Tank” on page W1-4-1.)

#### Removal

1. Remove the protection cover above the accumulator charging valve and travel shockless valve (1).

**IMPORTANT: Attach identification tags to disconnected hoses for re-assembly.**

2. Disconnect connectors (4) (2 used) and hoses (3) (5 used). Cap open ends.

 : 19 mm

3. Remove bolts (2) (2 used) and remove travel shockless valve (1).

 : 17 mm

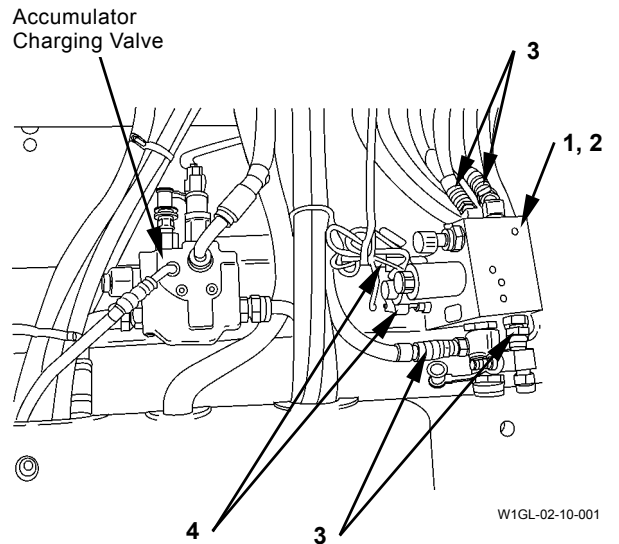

W1GL-02-10-001

#### Installation

1. Install travel shockless valve (1) with bolts (2) (2 used).

 : 17 mm

 : 50 N·m (5.1 kgf·m, 37 lbf·ft)

2. Connect hoses (3) (5 used) and connectors (4) (2 used).

 : 19 mm

 : 29.5 N·m (3.0 kgf·m, 21.5 lbf·ft)



3. Install the removed covers.

## UPPERSTRUCTURE / Solenoid Valve

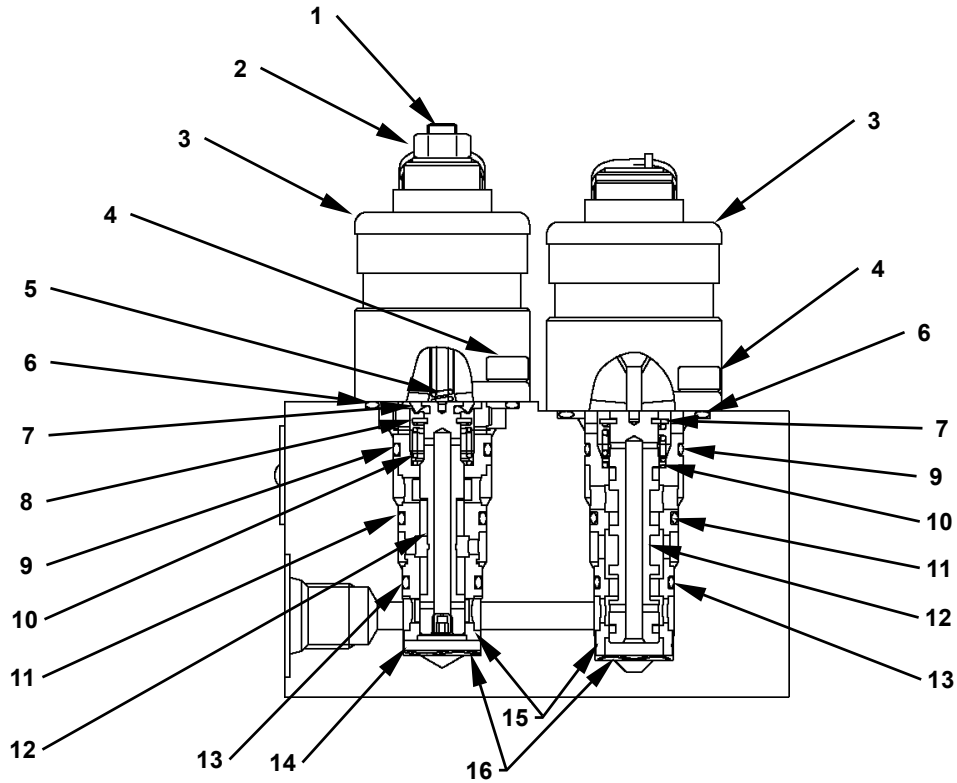
### CONSTRUCTION OF 2-UNIT SOLENOID VALVE (FOR PUMP CONTROL)



T1GL-03-10-001

Item No.	Part Name	Q'ty	Wrench Size (mm)	Tightening Torque			Remark
				N·m	(kgf·m)	(lbf·ft)	
1	Adjust Screw	1					
2	Lock Nut	1	 : 10	5 <sup>+2</sup> <sub>-0</sub>	0.5 <sup>+0.2</sup> <sub>-0</sub>	3.7 <sup>+1.5</sup> <sub>-0</sub>	
3	Solenoid	1					
4	Socket Bolt	2	 : 4	5 <sup>+2</sup> <sub>-0</sub>	0.5 <sup>+0.2</sup> <sub>-0</sub>	3.7 <sup>+1.5</sup> <sub>-0</sub>	
5	Spring	1					
6	O-Ring	1					
7	Diaphragm	1					
8	Washer	1					
9	O-Ring	1					
10	Spring	1					
11	O-Ring	1					
12	Spool	1					
13	O-Ring	1					
14	Plate	1					
15	Sleeve	1					
16	Washer	1					

## UPPERSTRUCTURE / Steering Valve

---

7. Remove seal (11) and dust seal (7) from bushing (9).

 *NOTE: Take care not to damage bushing (9) when removing seal (11).*

8. Remove bearing races (12) (2 used) and thrust needle (13) from spool (19).

9. Remove spool (19) and the sleeve (16) assembly from housing (15).

 *NOTE: Remove the sleeve (16) assembly from housing (15) while slowly turning the sleeve (16) assembly so that sleeve (16) doesn't score housing (15).*

10. Remove pin (18) from the sleeve (16) assembly.
11. Push spool (19) of sleeve (16) inside into forward slightly then remove center springs (17) (6 used) from spool (19).
12. Turn spool (19) lightly while removing it from sleeve (16).
13. Remove O-ring (10) from housing (15)
14. Remove plug (35) from housing (15).
15. Remove spring (37), poppet (38) and valve seat (39) from housing (15) with a magnet.

## UPPERSTRUCTURE / Brake Valve

### REMOVE AND INSTALL BRAKE VALVE

**CAUTION:** Be sure to bleed air from hydraulic oil tank before starting the work.  
(Refer to “Bleeding Air from Hydraulic Oil Tank” on page W1-4-1.)

#### Removal

**IMPORTANT:** Attach tags to the disconnected hoses to aid re-assembling.

1. Disconnect hoses (1) (6 used) from brake valve (2). Cap the disconnected hose ends.

 : 17, 22, 27 mm

2. Remove bolts (4) (4 used) from frame (3) to remove brake valve (2).

 : 17 mm

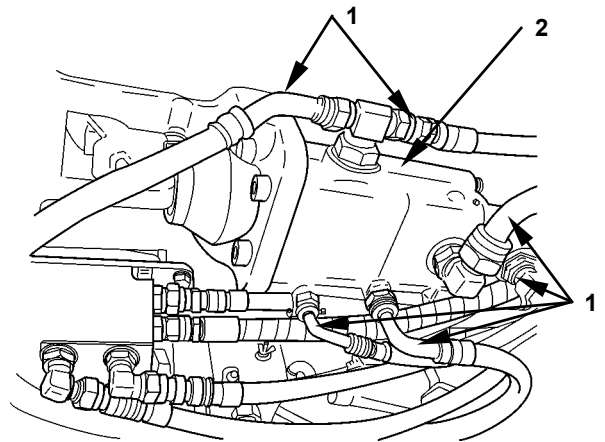

W1F3-02-14-001

#### Installation

1. Install brake valve (2) to frame (3) with bolts (4) (4 used).

 : 17 mm

 : 50 N·m (5.1 kgf·m, 37 lbf·ft)

2. Connect all hoses (1) (6 used) to brake valve (2).

 : 17 mm

 : 24.5 N·m (2.5 kgf·m, 18 lbf·ft)

 : 22 mm

 : 39 N·m (4.0 kgf·m, 29 lbf·ft)

 : 27 mm

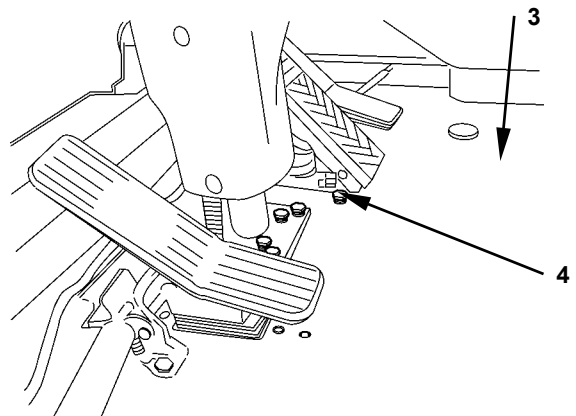

 : 78 N·m (8.0 kgf·m, 58 lbf·ft)



W1F3-02-14-002

## UPPERSTRUCTURE / Brake Valve

---

16. Secure the cylinder assembly in a vice with the S cylinder (39) side facing down.
17. Install bracket (25) to T flange (27) with socket bolts (24) (4 used).  
 : 60 to 75 N·m  
(6.0 to 7.5 kgf·m, 43 to 54 lbf·ft)
18. Install boots (23), stopper (22) and seat (21) to T flange (27).
19. Apply grease onto all pin hole of brake pedal (2), bracket (25), yoke (15) and link (17).
20. Install yoke (15) into brake pedal (2) with pin (12) and spring pin (13).
21. Install roller (18), washers (20) (2 used) onto link (17) with pin (16). Lock them with cotter pin (3).
22. Install the link (17) assembly with pin (10) and bracket (25). Lock them with cotter pin (3).
23. Install boots (11) to the brake pedal (2) assembly, then install it to bracket (25) with pin (8). Lock them with cotter pin (3).
24. Install yoke (15) to link (17) with pin (16), lock them with cotter pin (3).
25. Adjust the play of link (17) with stopper bolt (4) to 0 mm.
26. Secure link (17) with lock nut (6).  
 : 6.0 to 10 N·m  
(0.6 to 1.0 kgf·m, 4.3 to 7.2 lbf·ft)
27. Install rubber (1) onto brake pedal (2).



# UNDERCARRIAGE / Swing Bearing

## Assemble Swing Bearing

**IMPORTANT:** Be sure to apply grease to balls (6) and to supports (9).

**CAUTION:** Swing bearing weight: 220 kg (490 lb)

1. Lift the outer race horizontally and match it with the inner race coaxially. Rotating the outer race, insert balls (6), support (9) into the plug hole one by one with a round bar.

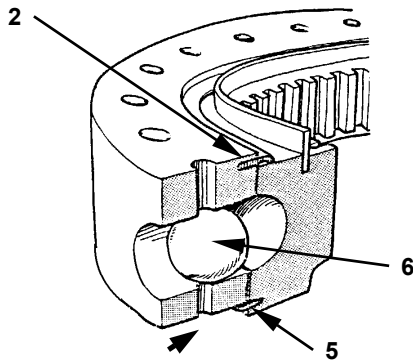

W142-03-01-005

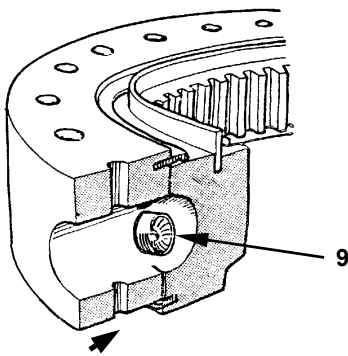

W142-03-01-006

2. Tap plug (4) into outer race (1) and then, drive pin (3) into the pin hole. Crimp the head of pin (3) with a punch.

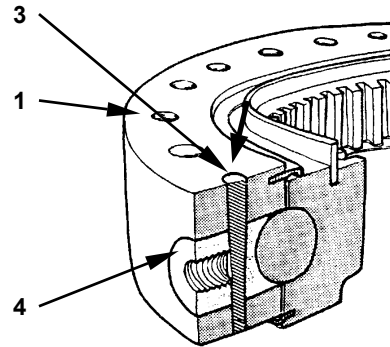

W142-03-01-007

3. Install lifting tools (ST 0050) onto outer race (4) and lift outer race (4). Thoroughly degrease the slots for seals (2, 5). Apply THREEBOND # 1745 (to seal (2)) and # 1735 (to seal (5)). Then assemble seals (2, 5) into the slots.
4. Fill grease 0.5 L (0.132 US gal) (Alvania EP2 grease or equivalent) through the grease fitting (8). Rotate the outer race while filling.

**NOTE:** Fill grease from two places (0.30 L).

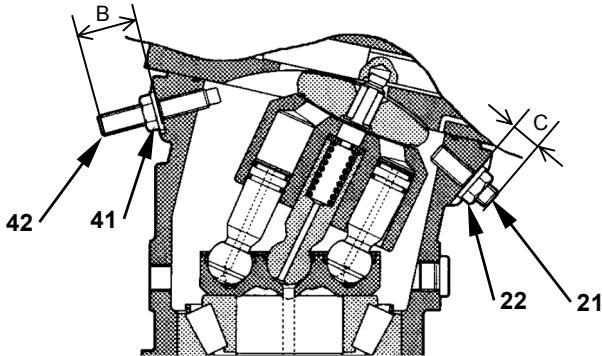

## UNDERCARRIAGE / Travel Motor

12. Record measurements of B, C parts before removing lock nuts (22), (41) and adjusting screws (21), (42).



W1GL-03-02-005

13. Loosen lock nuts (22), (41) to remove adjusting screws (21), (42).

 : 19 mm  
 : 6 mm

14. Install adjusting screw (42) (M12, Pitch 1.75 mm (0.1 in), Length 100 mm (3.9 in)) into the location where adjusting screw (21) is inserted, the angle of center shaft (39) should be zero.

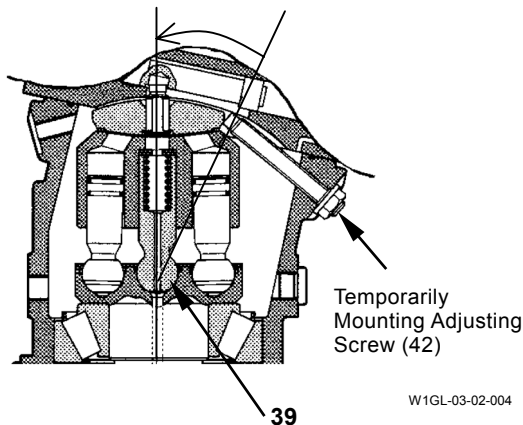

W1GL-03-02-004

15. Put matching marks onto the contact surface of head cover (1) and housing (36). Remove socket bolts (55) (8 used) to remove head cover (1) from housing (36).

 : 14 mm

16. Secure rotor (23) with screw bar (M8, Pitch 1.25 mm (0.05 in), Length 120 mm (4.7 in)) to prevent rotor (23) removing, then remove adjusting screw (42).

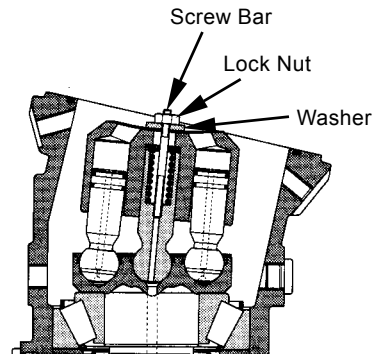

W1GL-03-02-003

17. Place housing (36) horizontally. Remove key (33) from drive shaft (37).

18. Remove retaining ring (34) from housing (36) to remove shim (32).

19. Place housing (36) assembly on press stand with rotor (23) side facing down. Pull drive shaft (37) assembly out.

20. Pull oil seal (31) out from housing (36).

## UNDERCARRIAGE / Travel Motor

---

### Disassemble Brake Valve

1. Remove socket bolts (13) (4 used) to remove cover (12) from valve casing (14).

 : 10 mm

2. Remove socket bolts (3) (4 used) to remove cover (2) from valve casing (14).

 : 10 mm

**IMPORTANT: Be sure to turn counterbalance valve when pulling it out. It may be stuck otherwise.**

3. Turn counterbalance valve (15) while pulling it out from valve casing (14) slowly.



**CAUTION: When removing plug (4), spring (5) will fly out due to spring force.**

4. Remove plugs (4) (2 used), springs (5) (2 used) and check valve (6).

 : 36 mm

5. Pull check valve assembly (11) out from valve casing (14) with a socket wrench.

6. Remove plug (8) from valve casing (14).

7. Pull shuttle valve (10) out from valve casing (14) with a socket wrench.

 : 4 mm

8. Remove plug (16) from valve casing (14).

9. Remove orifice (17) from valve casing (14).

 : 3 mm

## UNDERCARRIAGE / Center Joint

### Assemble Center Joint



**CAUTION:** Body (4) weight: 40 kg (89 lb)

1. Install O-rings (2, 12) into body (4).



**NOTE:** If bushing (3) is removed, be sure to reinstall bushing (3) before reassembling.

2. Install oil seals (5) (15 used) into body (4).

**IMPORTANT:** After installing the seals, apply grease to the inner wall of body (4), and the seals.

3. Put spindle (1) on workbench, install spindle (1) into body (4), align the mating marks made during disassembly.

**IMPORTANT:** Slowly and straightly insert spindle (1) along with the center of body (4), because the clearance between body (4) and spindle (1) is approximately 0.1 mm.

4. Tap body (4) lightly with a plastic hammer, insert body (4) until it touches spindle (1).

5. Install plate (11) onto spindle (1) with bolts (8) (4 used).

 : 17 mm

 : 49 N·m (5 kgf·m, 36 lbf·ft)

6. Install O-ring (7) to body (4) and install O-ring (9) to spindle (1).

7. Install cover (10) with bolts (6) (6 used).

 : 17 mm

 : 49 N·m (5 kgf·m, 36 lbf·ft)

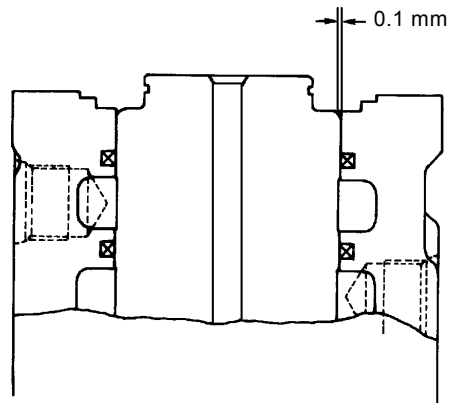

W105-03-03-024

## UNDERCARRIAGE / Transmission

---

1 - Flange	15 - O-Ring	29 - Friction Plate (11 Used)	43 - Shim
2 - Relief Valve	16 - O-Ring	30 - Plate (10 Used)	44 - Friction Plate (6 Used)
3 - Shaft	17 - Seal Ring	31 - Spacer	45 - Piston
4 - Retaining Ring	18 - Backup Ring (2 Used)	32 - Retaining Ring	46 - Disc Spring (3 Used)
5 - O-Ring	19 - Piston	33 - Shim	47 - Gear Case
6 - Drive Case	20 - Retaining Ring	34 - Retaining Ring	48 - Socket Bolt (9 Used)
7 - Plug	21 - O-Ring	35 - U-Ring	49 - Disc Spring (2 Used)
8 - O-Ring	22 - Gasket	36 - O-Ring	50 - Seal
9 - Spring	23 - O-Ring	37 - Bearing	51 - Ring
10 - Bearing	24 - Seal Ring	38 - Sun Gear	52 - O-Ring (2 Used)
11 - Retaining Ring	25 - Plate	39 - Cover	53 - Retaining Ring
12 - Piston Ring (2 Used)	26 - Retaining Ring	40 - Retaining Ring	54 - Pipe
13 - Piston	27 - Ring Gear	41 - Disc Carrier	55 - Hose (2 Used)
14 - Seal Ring	28 - Plate	42 - Plate (6 Used)	129 - Retaining Ring
			130 - Plate

## UNDERCARRIAGE / Transmission

---

47 - Gear Case	89 - Gear	99 - Lock Plate	120 - Thrust Washer (4 Used)
80 - Bearing	90 - Seal	100 - Bolt (2 Used)	121 - Pinion Gear (4 Used)
81 - Cover	91 - Cover	112 - Plate	122 - Differential Case
82 - Bolt (4 Used)	92 - Bearing	113 - Roll Pin (2 Used)	123 - Socket Bolt (8 Used)
83 - Cap	93 - Seal	114 - Bearing (2 Used)	124 - Socket Bolt (4 Used)
84 - Drive Pinion	94 - Plate	115 - Nut (2 Used)	125 - Spring Pin (4 Used)
85 - Bushing	95 - Flange	116 - Bevel Gear	126 - Spring Pin (4 Used)
86 - Bolt (12 Used)	96 - Bolt (8 Used)	117 - Differential Case	127 - Spider
87 - O-Ring	97 - O-Ring	118 - Thrust Washer (2 Used)	
88 - O-Ring	98 - Plate	119 - Side Gear (2 Used)	

## UNDERCARRIAGE / Transmission

---

1 - Flange	15 - O-Ring	29 - Friction Plate (11 Used)	43 - Shim
2 - Relief Valve	16 - O-Ring	30 - Plate (10 Used)	44 - Friction Plate (6 Used)
3 - Shaft	17 - Seal Ring	31 - Spacer	45 - Piston
4 - Retaining Ring	18 - Backup Ring (2 Used)	32 - Retaining Ring	46 - Disc Spring (3 Used)
5 - O-Ring	19 - Piston	33 - Shim	47 - Gear Case
6 - Drive Case	20 - Retaining Ring	34 - Retaining Ring	48 - Socket Bolt (9 Used)
7 - Plug	21 - O-Ring	35 - U-Ring	49 - Disc Spring (2 Used)
8 - O-Ring	22 - Gasket	36 - O-Ring	50 - Seal
9 - Spring	23 - O-Ring	37 - Bearing	51 - Ring
10 - Bearing	24 - Seal Ring	38 - Sun Gear	52 - O-Ring (2 Used)
11 - Retaining Ring	25 - Plate	39 - Cover	53 - Retaining Ring
12 - Piston Ring (2 Used)	26 - Retaining Ring	40 - Retaining Ring	54 - Pipe
13 - Piston	27 - Ring Gear	41 - Disc Carrier	55 - Hose (2 Used)
14 - Seal Ring	28 - Plate	42 - Plate (6 Used)	129 - Retaining Ring
			130 - Plate

## UNDERCARRIAGE / Axle

### REMOVE AND INSTALL AXLE

**CAUTION:** Be sure to bleed air from hydraulic oil tank before starting the work. (Refer to “Bleeding Air from Hydraulic Oil Tank” on page W1-4-1.)

#### Removal of Front Axle

1. Loosen mounting nuts (1) (20 used) from tires (3) (4 used) and tire rings (2) (2 used).  
🔧 : 30 mm

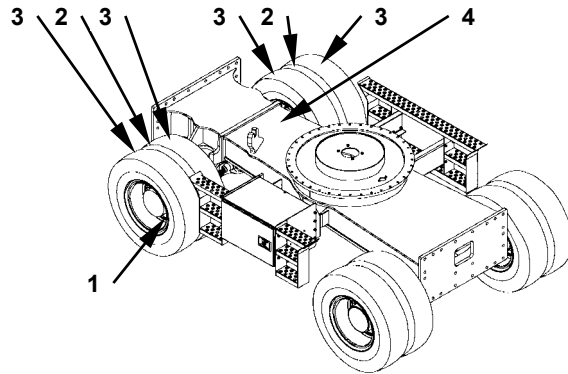

W1GL-03-05-003

2. Jack up frame (4) with tire (3) floated then put the blocks under the machine.

**CAUTION:** Tire (3) weight: 98 kg (220 lb)  
Tire ring (2) weight: 17 kg (38 lb)

3. Remove nuts (1) (20 used) to remove tires (3) (4 used) and tire rings (2) (2 used).  
🔧 : 30 mm
4. Disconnect brake hoses (5) (2 used) and grease hose (10).  
🔧 : 17 mm, 22 mm
5. Disconnect steering hoses (2 used).  
🔧 : 22 mm

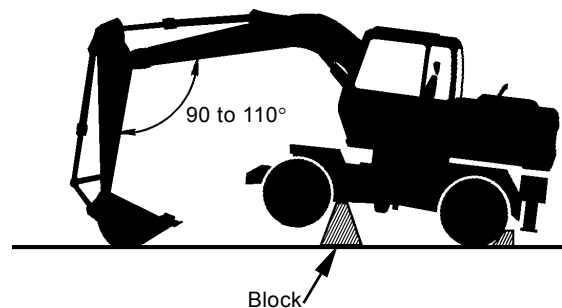

SA-096

**CAUTION:** Propeller shaft weight: 20 kg (44 lb)

6. Remove nuts (12) (8 used) to remove propeller shaft (11).  
🔧 : 14 mm
7. Remove nuts (6) (2 used) to remove bolt (8).  
🔧 : 24 mm

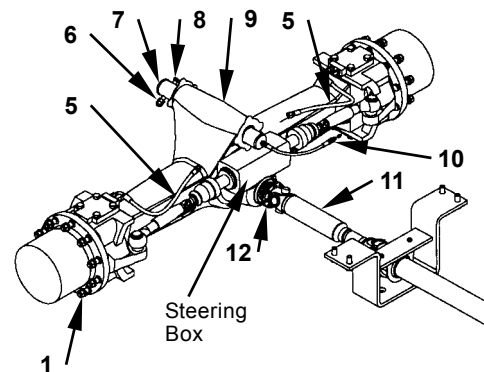

W1GL-03-05-001

**CAUTION:** Front axle (9) weight: 590 kg (1300 lb)

**CAUTION:** Pin (7) weight: 18 kg (40 lb) (Outer Diameter 70 mm (2.8 in))

8. Lift front axle (9) off to remove pin (7), then remove front axle (9).

CLICK HERE TO **DOWNLOAD** THE COMPLETE MANUAL

- Thank you very much for reading the preview of the manual.
- You can download the complete manual from: [www.heydownloads.com](http://www.heydownloads.com) by clicking the link below



- Please note: If there is no response to CLICKING the link, please download this PDF first and then click on it.



CLICK HERE TO **DOWNLOAD** THE COMPLETE MANUAL

## UNDERCARRIAGE / Axle

---

14. Remove retaining ring (42) and plate (41) from ring gear (35).
15. Remove backup ring (33) and O-ring (32) from ring gear (35).
16. Remove O-ring (25) from hub carrier (24).
17. Remove backup ring (31) and O-ring (32) from joint housing (17).
18. Remove the hub carrier (24) assembly from joint housing (17).
19. Remove outer races of bearings (22, 26), bushing (23) and gasket ring (21) from hub gear (24).

**IMPORTANT: When removing bearing pins (19, 30), the inner race of bearing (5) should be removed together. Take care not to damage it.**

20. Remove bolts (29) (4 used) to remove bearing pin (30) and O-rings (3, 70) (2 used) from body (2).  
 : 24 mm
21. Remove bolts (20) (4 used) to remove bearing pin (19), shim (18) and O-ring (3) from body (2).  
 : 24 mm
22. Remove joint housing (17) from body (2).
23. Pull double joint shaft (14) out from body (2).
24. Remove seal rings (4) (2 used), O-rings (3) (2 used) and bearing inner races (2 used) from bearing pins (19, 30).
25. Remove shaft seals (7, 15) from joint housing (17) and body (2).
26. Remove outer races (2 used) of bearing (5) and seal rings (6) (2 used) from body (2). The other side should be removed in the same way.

 **NOTE:** Remove bushings (8, 16) from body (2) and joint housing (17) if necessary.

27. Remove bolts (10) (2 used), bolts (13) (7 used) and nuts (11) (3 used) to remove the differential assembly from body (2).  
 : 19 mm

## UNDERCARRIAGE / Axle

32. Install the planetary carrier (63) assembly to the hub carrier (24) assembly and secure them with bolts (61) (2 used).

 : 8 mm

 : 86 N·m (9 kgf·m, 65 lbf·ft)

33. Install plug (1) into body (2) and install plug (62) into planetary carrier (63).

Supply oil into the differential and the wheel hub, then install plugs (9, 71).

 : 8 mm

 : 69 N·m (7.0 kgf·m, 50 lbf·ft)

 : 22 mm

 : 79 N·m (8.0 kgf·m, 58 lbf·ft)

Differential

Front: 11.0 L (2.9 US gal.)

Rear: 13.0 L (3.4 US gal.)

Wheel Hub Front, Rear:

Each 2.0 L (0.5 US gal.) ×2

34. After assembling the front axle, install straight edge to adjust toe-in.

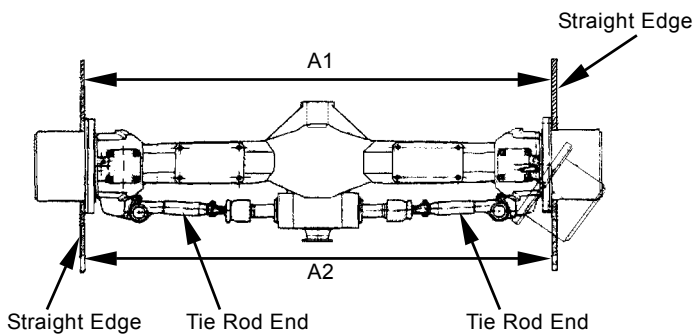

W1GL-03-05-017

Measure the dimension A1 between the notch marked on straight edge, and measure the dimension A2 after rotating both sides of wheel hub to 180°. Then adjust with tie rod end so that dimension of A1 and A2 is the same.

## UNDERCARRIAGE / Axle

### Assemble Rear Axle

1. Apply THREEBOND on the mating surface on knuckle (9) and body (4).
2. Align the mating marks, install knuckle (9) onto body (4) with bolts (18) (16 used).  
🔧 : 27 mm  
🔩 : 390 N·m (40 kgf·m, 209 lbf·ft)
3. Install screen sheet (10) and seal (42) to knuckle (9).
4. Install the outer race of bearing (12), bushing (13) and the outer race of bearing (16) to hub carrier (14) in order, then install gasket ring (11) together.
5. Install the inner race of bearing (12) to knuckle (9).
6. Install ring gear (31) to hub carrier (14), then temporarily tighten it with bearing nut (29).  
🔩 : 1200 to 1400 N·m  
(122 to 143 kgf·m, 880 to 1030 lbf·ft)
7. Measure the preload of hub carrier (14).  
Preload: 13 to 18 N·m  
(1.3 to 1.8 kgf·m, 9.4 to 13 lbf·ft)
8. If the preload is within specified value, remove bearing nut (29) and ring gear (31).
9. Install plate (24) and retaining ring (23) to ring gear (31).
10. Install rings (19, 36) and U-rings (20, 37) to piston (22).  
Apply grease after installing them.
11. Install piston (22) to the ring gear (31) assembly and secure it with bolts (27) (8 used), spring guides (26) (8 used), springs (25) (8 used) and nuts (21) (8 used).  
🔧 : 10 mm
12. Install bolt so that the dimension A should be 0.5 to 1.0 mm (0.02 to 0.04 in).  
🔧 : 10 mm  
🔩 : 10 N·m (1.1 kgf·m, 8 lbf·ft)
13. After adjusting, secure nuts (21) (8 used) with LOCTITE #242.

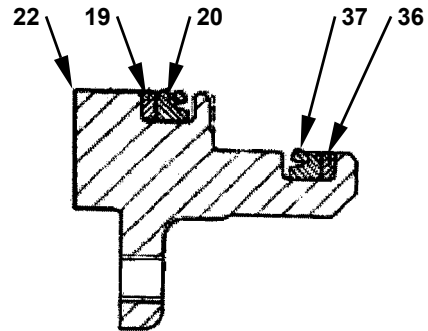

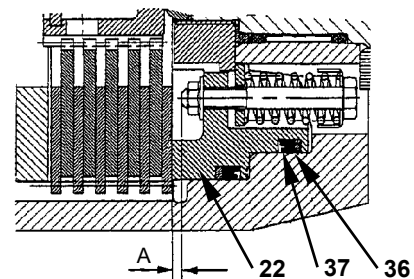

W1GL-03-05-011



W1GL-03-05-012

## UNDERCARRIAGE / Axle

---

17. Install the inner race of bearings (11) (2 used) to the differential.
18. Install roll pins (17) (2 used) to caps (10) (2 used).
19. Install the outer races (2 used) of bearing (11) to the differential.
20. Insert the differential assembly into housing (8) and install nuts (12) (2 used) together.
21. Install the differential assembly with caps (10) (2 used) and bolts (9) (4 used).
  -  : 22 mm
  -  : 195 N·m (20 kgf·m, 145 lbf·ft)
22. After adjusting the backlash and preload of bevel gear (16) and drive pinion (15), secure nut (12) with roll pins (17) (2 used).
  - The backlash is stamped on side surface of bevel gear (16) and the end of drive pinion (15).
  - Preload of drive pinion (15)  
1.0 to 1.4 N·m (0.1 to 0.14 kgf·m, 0.7 to 1.0 lbf·ft)

---

## UNDERCARRIAGE / Axle Lock Cylinder

---

### Disassemble Axle Lock Cylinder

- Be sure to read "Precautions for Disassembly and Assembly" thoroughly on page W1-1-1 before starting any repair work.



**CAUTION: Axle lock cylinder weight:  
61 kg (135 lb)**

1. Place the axle lock cylinder on a workbench horizontally.
2. Remove socket bolts (1) (4 used) to remove check valve (2).



**CAUTION: Housing (3) weight: 35 kg (78 lb)  
Rod (4) weight: 23.5 kg (52 lb)**

3. Supply air to the hole of the housing (3) port to push rod (4) out.
4. Remove retaining ring (5) from housing (3) to remove dust seal (6, 7).

### Assemble Axle Lock Cylinder

- Be sure to read "Precautions for Disassembly and Assembly" thoroughly on page W1-1-1 before starting any repair work.



**CAUTION: Housing (3) weight: 35 kg (78 lb)  
Rod (4) weight: 23.5 kg (52 lb)**

1. Install seal (7), dust seal (6) and retaining ring (5) to housing (3).

**IMPORTANT: Apply hydraulic oil to the inner surface of housing (3) and seals (6, 7).**

2. Install rod (4) to housing (3).



**CAUTION: Axle lock cylinder weight:  
61 kg (135 lb)**

3. Temporarily install check valve (2) to the housing (3) assembly with socket bolts (1) (2 used).

## UNDERCARRIAGE / Propeller Shaft

### Installation

1. Install bearing assembly (18) to propeller shaft (5).

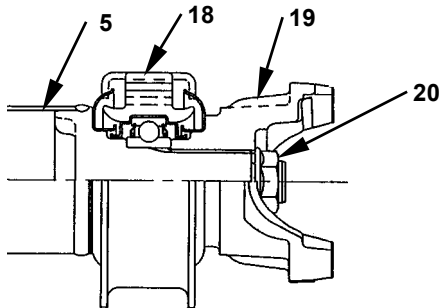

Detail of Part B

W1GL-03-08-002

2. Install yoke (19) to propeller shaft (5) then tighten it with nut (20).

 : 32 mm

 : 370 to 440 N·m

(38 to 45 kgf·m, 275 to 325 lbf·ft)

 **CAUTION: The propeller shaft (5) assembly weight: 30 kg (66 lb)**

3. Insert the yoke (19) mounting side of propeller shaft (5) into bracket (4) then install the flange (7) side to the transmission with nuts (8) (8 used).

 : 14 mm

 : 108 N·m (11 kgf·m, 80 lbf·ft)

4. Install the propeller shaft (5) assembly to bracket (4) with bolts (3) (2 used).

 : 17 mm

 : 65 N·m (6.6 kgf·m, 48 lbf·ft)

**IMPORTANT: Check that inside of needle bearings (15) (2 used) has no contaminant. Take care not to contaminate the needle bearing because it maybe shorten the service life of the needle bearing.**

5. Apply grease on needle bearings (15) (2 used) and install them to spider (14).

 **CAUTION: The propeller shaft (2) assembly weight: 20 kg (44 lb)**

6. Install the propeller shaft (2) assembly to yoke (19) with bolts (9) (4 used) and bearing strap (6).

 : 11 mm

 : 61 to 81 N·m

(6.3 to 8.2 kgf·m, 46 to 59 lbf·ft)

7. Install the flange (10) side to the transmission with nuts (1) (8 used).

 : 14 mm

 : 108 N·m (11 kgf·m, 80 lbf·ft)

8. Install grease fitting (12) to fork (13) then supply grease.

## FRONT ATTACHMENT / Front Attachment

**⚠ CAUTION: Boom foot pin (12) weight:  
45 kg (100 lb)**

11. Remove bolt (15), spring washer (16), plate (14) and block (13) from the plate of boom foot pin (12).

 : 27 mm

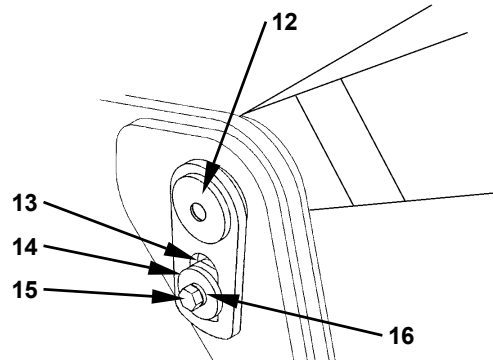

W178-04-01-001

**⚠ CAUTION: Front attachment weight:  
3330 kg (7350 lb)**

12. Attach a wire rope onto the boom. Slightly hoist to take up any slack of wire rope.

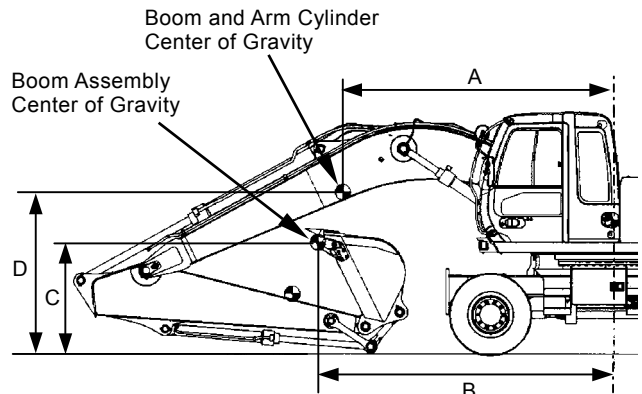

W1GL-04-01-002

13. Insert a bar between the plate of boom foot pin (12) and the bracket. Slightly pull the plate out.

14. Pull boom foot pin (12) out while rotating the plate slowly by hand.

**✎ NOTE:** When boom foot pin (12) cannot be removed, adjust the position of the boom foot pin (12) hole by hoisting and lowering the front attachment.

15. After hoisting the front attachment, move the machine backward.

16. Place the front attachment on wooden blocks.

Unit: mm (in)

A	3492 (137.5)
B	3813 (150)
C	1422 (56)
D	2064 (81.3)

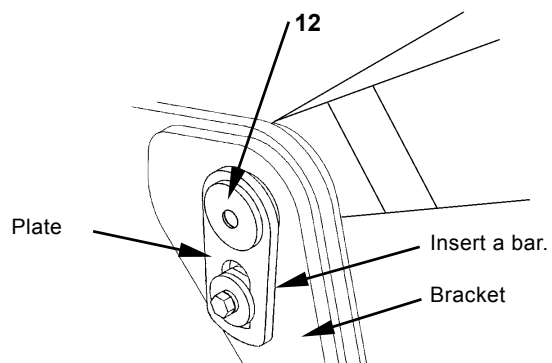



W178-04-01-001

## FRONT ATTACHMENT / Front Attachment

5. Remove the caps from hoses and pipings. Install bucket cylinder hoses (7) and arm cylinder hoses (8).

 : 41 mm

 : 205 N·m (21 kgf·m, 151 lbf·ft)

 : 36 mm

 : 175 N·m (18 kgf·m, 130 lbf·ft)

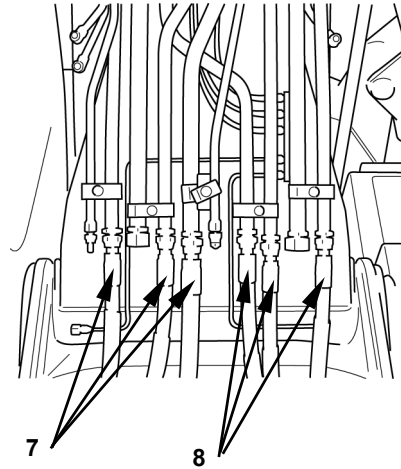

W1GL-04-01-009



**CAUTION: Boom cylinder weight:  
172 kg (380 lb)**

6. Install the boom cylinder.  
Refer to "Install Boom Cylinder" on page W4-2-12.

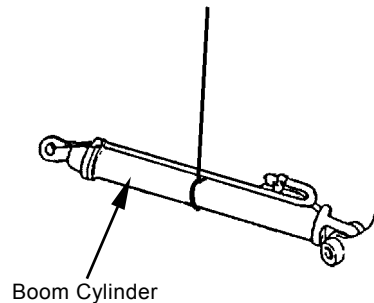

W105-04-02-040

7. Hoist the boom cylinder by a crane. Insert thrust plates (2) (2 used), and then drive in pin (3) to install boom cylinders to both sides.

8. Install stopper (5) and secure it with bolt (6) and nuts (4) (2 used). (2 places both left and right)

 : 30 mm

 : 550 N·m (56 kgf·m, 405 lbf·ft)

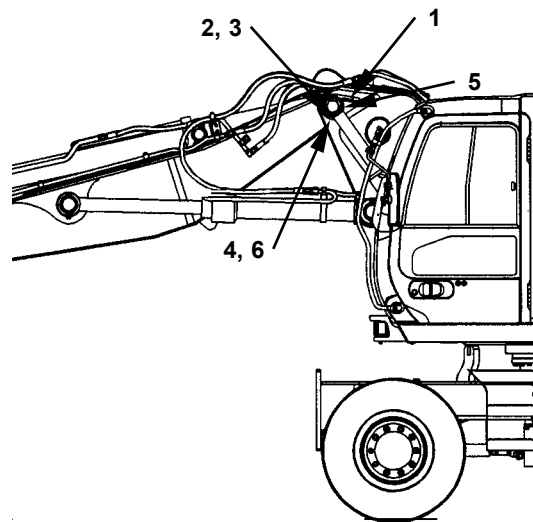

W1GL-04-01-008

## FRONT ATTACHMENT / Cylinder

### Install Bucket Cylinder

**IMPORTANT:** When pressing the bushing in, if a hammer is used, the bushing may be damaged. Use a press.

**CAUTION:** Prevent person from injury. Metal fragments may fly when a hammer is used to install the pins. Be sure to wear necessary protection, such as goggles, hardhats and etc.

**CAUTION:** Bucket cylinder weight:  
145 kg (320 lb)

1. Lift bucket cylinder (1). Align cylinder tube side pin hole with the bucket cylinder mounting hole on arm. Install thrust plate (10) and pin (11).
2. Insert bolt (15) into arm stopper (14) and pin (11). Install nut (13).  
🔧 : 180 N·m (18.5 kgf·m, 133 lbf·ft)
3. Connect the bucket cylinder hoses (12) (2 used).  
🔧 : 36 mm  
🔧 : 175 N·m (18 kgf·m, 130 lbf·ft)
4. Remove wire (9) from rod (8) of bucket cylinder (1).

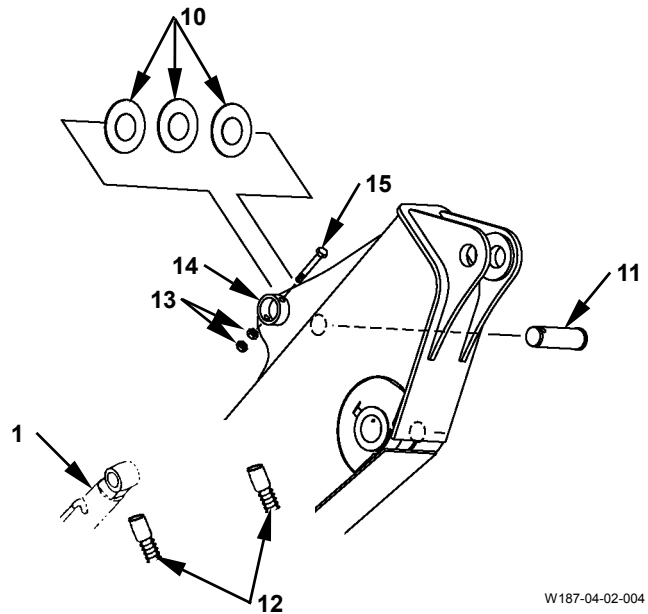

W187-04-02-004

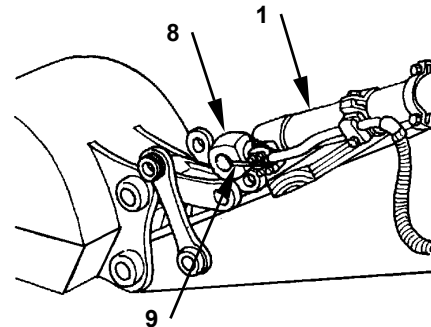

W102-04-02-005

## FRONT ATTACHMENT / Cylinder

### Remove Positioning Cylinder (2-Piece Boom Only)

**CAUTION:** Prevent person from injury. Metal fragments may fly when a hammer is used to remove the pins. Be sure to wear necessary protection, such as goggles, hardhat and etc.

**CAUTION:** Positioning cylinder weight:  
167 kg (370 lb)

1. Attach a nylon sling to positioning cylinder (3). Lift and hold positioning cylinder (3).
2. After stopping the engine, push the pressure release button on the air breather to release any remaining pressure from the hydraulic oil tank. Then remove the cap. Release the positioning circuit pressure. (Refer to "Hydraulic Circuit Pressure Release Procedure" on page W4-1-1.)
3. Remove nuts (5) (2 used) and bolt (1) from stopper (4) of the second boom.
4. Drive pin (2) into the second boom at approx. 160 mm (6.3 in)
5. Disconnect hoses (6) (2 used) and hoses (7) (3 used) from positioning cylinder (3). Attach a cap onto the open ends.
6. Remove nuts (10) (2 used) and bolt (11) from stopper (8) of the first boom. Drive pin (9) in with a bar and hammer.

**CAUTION:** Positioning cylinder weight:  
167 kg (370 lb)

7. Lift positioning cylinder (3) off.

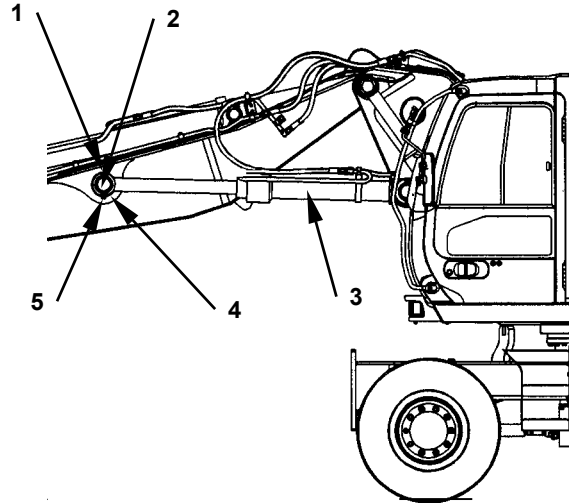

W1GL-04-01-008

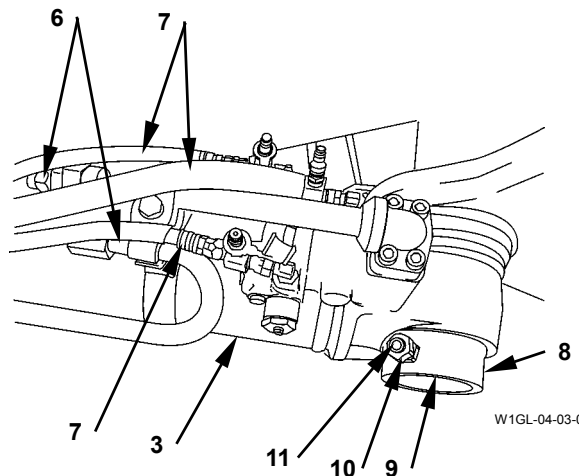

W1GL-04-03-004

## FRONT ATTACHMENT / Cylinder

### Assemble Boom (Monoblock/2-Piece), Positioning and Bucket Cylinders

1. Press bushing (5) into cylinder head (7).

Tools for installing bushing:

Boom (Monoblock)/Bucket	: 80 mm (ST 8019)
Boom (2-Piece)	: 85 mm (ST 8020)
Positioning	: 95 mm (ST 8021)

#### **IMPORTANT: Be sure to install rings in correct direction.**

2. Install U-ring (3), backup ring (2), buffer ring (4), and snap ring (6) to cylinder head (7).

3. Install wiper ring (1) to cylinder head (7) with a plastic hammer.

Tools for installing wiper ring :

Boom (Monoblock)/Bucket	: ST 8019/1297
Boom (2-Piece)	: ST 8020/1298
Positioning	: ST 8021/1299

4. Install O-ring (10) and backup ring (9) to cylinder head (7).

5. Install O-ring (18), backup rings (16) (2 used), seal ring (17), and slide rings (19, 20) (2 used for each) to piston (15).

6. Install the cylinder head (7) assembly into piston rod (11).

Tools for installing cylinder head:

Boom (Monoblock)/Bucket	: ST 8019/2345
Boom (2-Piece)	: ST 8020/2362
Positioning	: ST 8021/2363

#### **IMPORTANT: Be sure that the slit in cushion seal (14) is facing piston and that the oil groove in cushion bearing (13) is facing correct direction.**

7. Install cushion bearing (13) to piston rod (11). Install the piston (15) assembly to the piston rod (11).

In case of the boom and positioning cylinders, install cushion seal (14).

8. Install shim (21) to cylinder rod (11). Tighten nut (24) using special tool (ST 5908) while aligning the mating mark on the rod with that on nut (24).

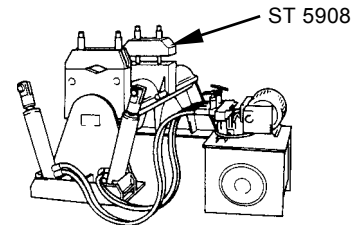

W158-04-02-022

Tools for tightening nut:

Boom (Monoblock)/Bucket	: 90 mm (ST 3263)
Boom (2-Piece)	: 95 mm (ST 3075)
Positioning	: 100 mm (ST 3264)

Boom cylinder (Monoblock)

⚔ : 4780 N·m (490 kgf·m, 3530 lbf·ft)

Boom cylinder (2-Piece)

⚔ : 5470 N·m (560 kgf·m, 4030 lbf·ft)

Positioning cylinder

⚔ : 6850 N·m (700 kgf·m, 5050 lbf·ft)

Bucket cylinder

⚔ : 6570 N·m (670 kgf·m, 4850 lbf·ft)

9. Align the holes of piston rod (11) and nut (24), then install steel ball (23).

10. Crimp the head of set screw (22) at two places with a punch.

⚔ : 57±10.5 N·m

(5.8±1.1 kgf·m, 42±7.7 lbf·ft)

#### **IMPORTANT: Take care not to damage rings. Install the piston rod (11) assembly into cylinder tube (12) while aligning it with the center of cylinder tube (16).**

11. Horizontally secure cylinder tube (12) on a workbench. Insert the piston rod (11) assembly into cylinder tube (12).

12. Install cylinder head (7) into cylinder tube (12) with socket bolts (8) (12 used).

Boom/ Bucket cylinder

⚔ : 265 N·m (27 kgf·m, 195 lbf·ft)

Positioning cylinder

⚔ : 370 N·m (38 kgf·m, 270 lbf·ft)



## FRONT ATTACHMENT / Hose-Rupture Safety Valve

### REMOVE AND INSTALL HOSE-RUPTURE SAFETY VALVE











#### Removal of Hose-Rupture Safety Valve for Arm Cylinder

1. After stopping the engine, push the pressure release button on the air breather to release any remaining pressure from the hydraulic oil tank. Then remove the cap.  
Release the arm circuit pressure. (Refer to "Hydraulic Circuit Pressure Release Procedure" on page W4-1-1.)

#### **IMPORTANT: Attach identification tags to the hydraulic hoses and pipes for re-assembly.**

2. Disconnect hoses (2) and (5) (2 used) from hose-rupture safety valve (6).  
Attach a cap onto the open ends.  
 : 17 mm, 19 mm, 27 mm
3. Remove socket bolts (4) (4 used) then remove pipe (3) from hose-rupture safety valve (6).  
 : 10 mm
4. Remove socket bolts (1) (4 used) then remove hose-rupture safety valve (6) from the arm cylinder.  
 : 10 mm

#### Installation of Hose-Rupture Safety Valve for Arm Cylinder

1. Install hose-rupture safety valve (6) onto the arm cylinder with socket bolts (1) (4 used).  
 : 10 mm  
 : 93±2 N·m (9.5±0.2 kgf·m, 69±1.5 lbf·ft)
2. Install pipe (3) onto hose-rupture safety valve (6) with socket bolts (4) (4 used).  
 : 10 mm  
 : 108 N·m (11 kgf·m, 80 lbf·ft)
3. Connect hoses (2) and (5) (2 used).  
 : 17 mm  
 : 24.5 N·m (2.5 kgf·m, 18 lbf·ft)  
 : 19 mm  
 : 29.5 N·m (3.0 kgf·m, 21.5 lbf·ft)  
 : 27 mm  
 : 78 N·m (8 kgf·m, 58 lbf·ft)

**IMPORTANT: Fill hydraulic oil to the specified level. Start the engine. Check the connections for any oil leakage.**

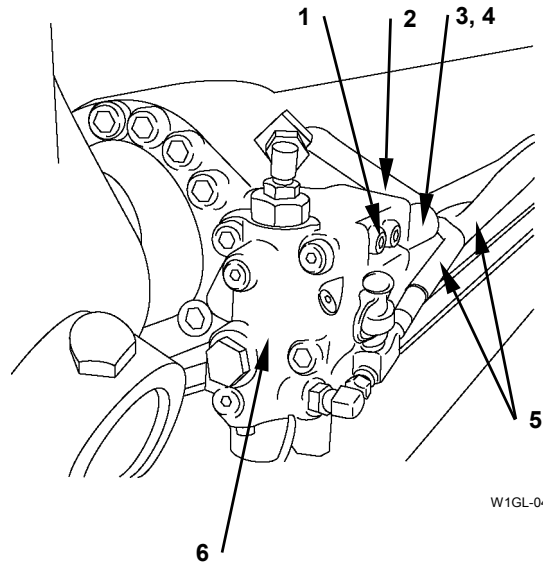

W1GL-04-03-005



## PERFORMANCE CURVE

### MODEL AA-6BG1TRA

#### CONDITION:

Ambient condition	: JIS standard	Air cleaner	: None
Break-in	: More than 30 hours	Alternator	: No Load
Cooling fan	: 650φ	Exhaust silencer	: None

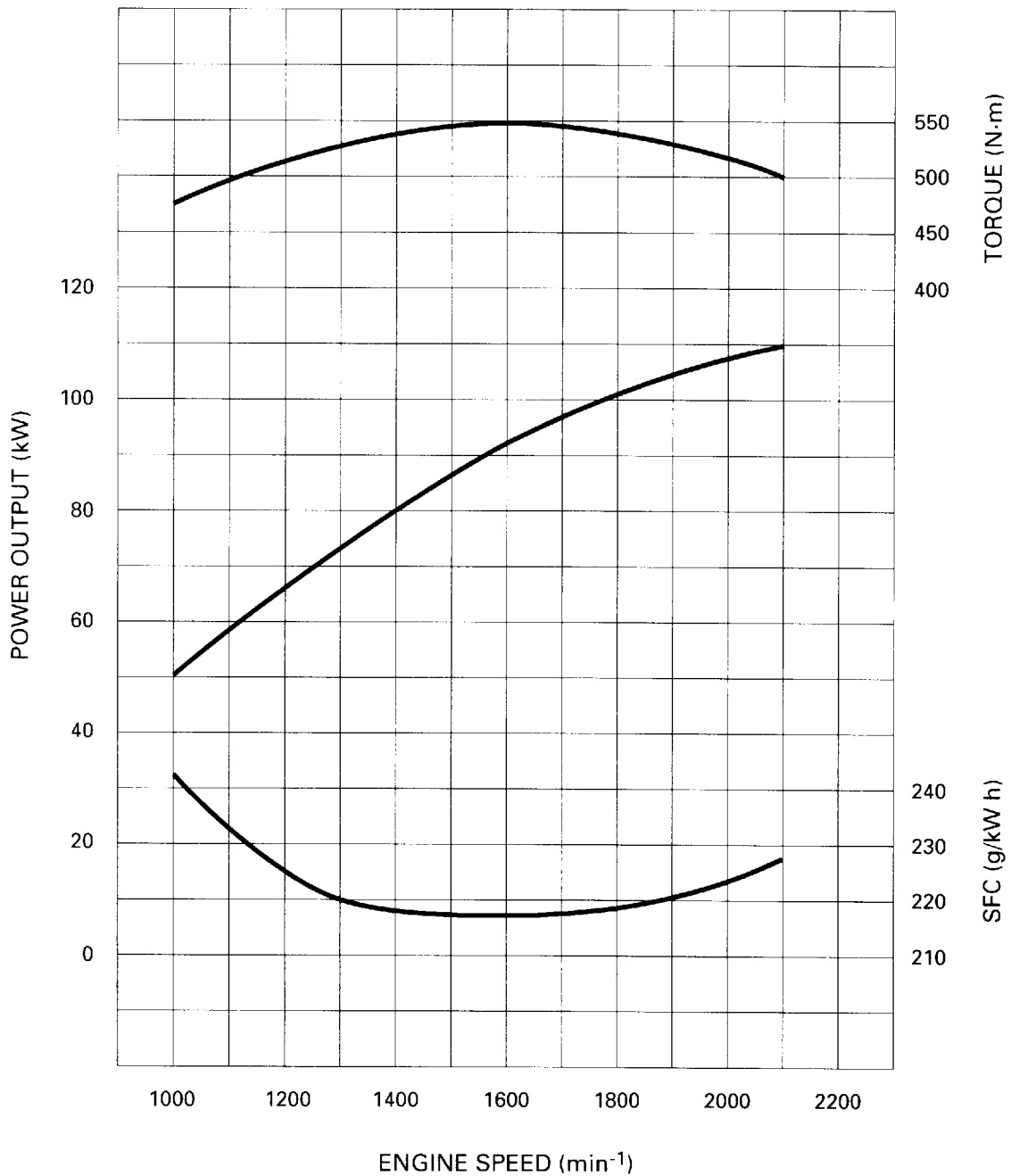

Oil Pan and Dipstick

N·m (kgf·m/lb.ft)

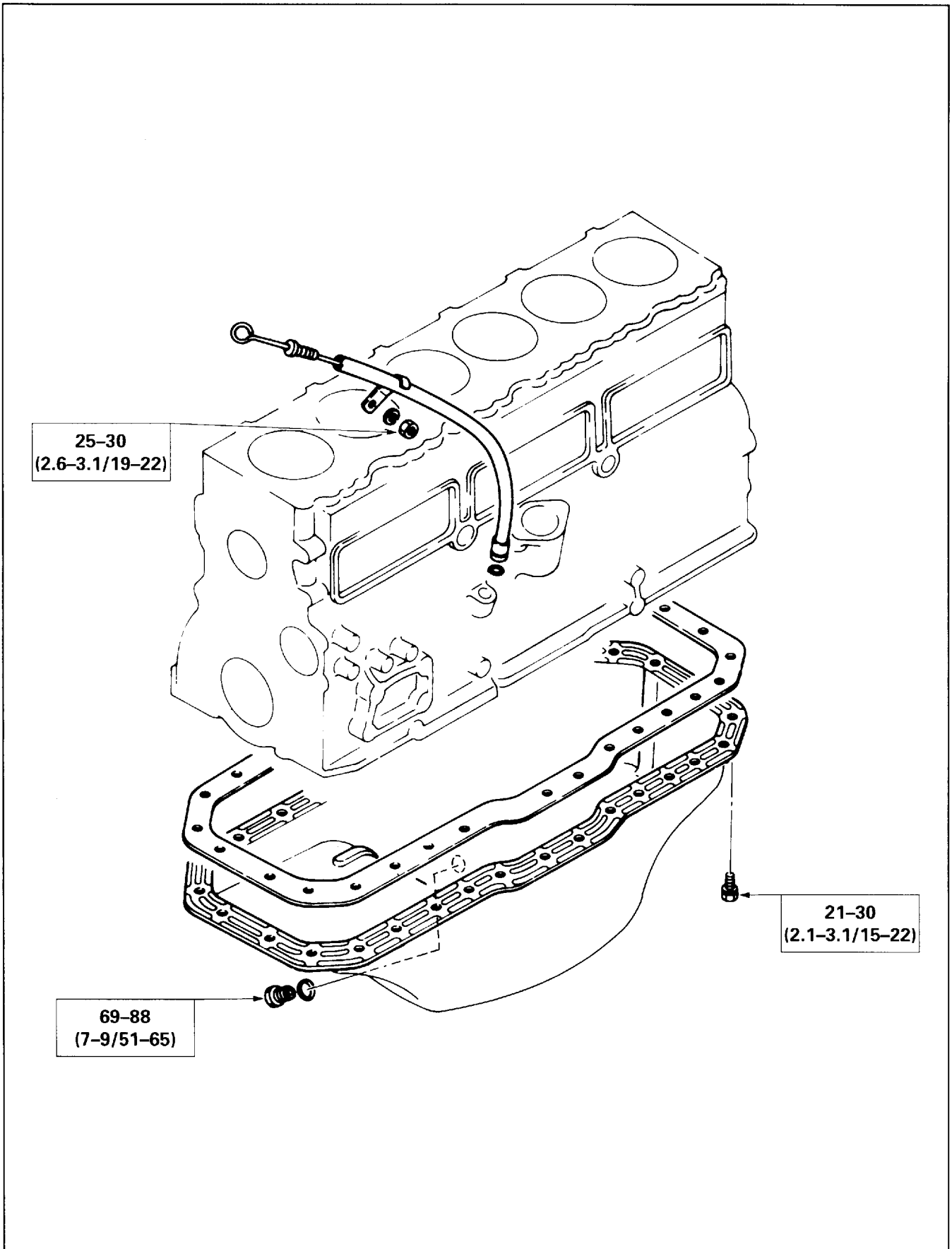

SECTION 2

**MAINTENANCE**

TABLE OF CONTENTS

ITEM	PAGE
Lubricating system .....	2- 2
Fuel system .....	2- 3
Cooling system .....	2- 7
Valve clearance adjustment .....	2- 7
Injection timing .....	2- 9
Compression pressure measurement.....	2-14
Turbocharger inspection .....	2-15
Engine repair kit.....	2-16
Recommended lubricants.....	2-17
Engine oil viscosity chart .....	2-17

**Note:** Maintenance intervals such as fuel or oil filter changes should be referred to INSTRUCTION BOOK.

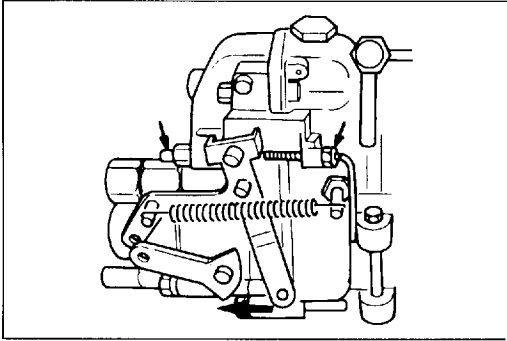

6. Hold the fuel control lever at the fully open position.

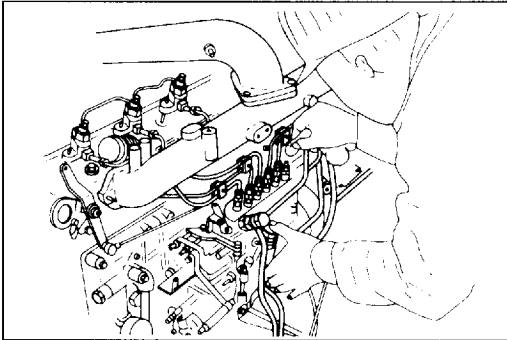

7. Slowly turn the crankshaft pulley clockwise, at the same time, continue to feed the fuel with pumping the priming pump.

When the fuel stop to flow out from the No. 1 delivery valve holder, stop the pump instantaneously.

This crankangle position is the injection starting of the engine.



8. Observe and make sure that mark (injection starting angle line  $\alpha^\circ$ ) on the crankshaft pulley is aligning with the pointer.

The timing line shows the injection starting angle of the engine.

Blow out the remaining fuel from the delivery valve holder.

Make sure that there is no fuel being delivered from the priming pump.

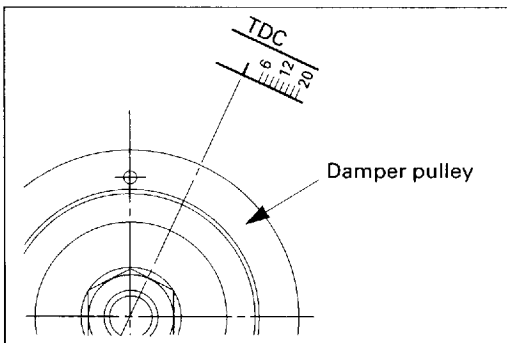

015ES002

**Note**

6BG1 engine has eight timing notch lines punched on the crankshaft damper pulley.

These notched lines must be aligned for correct engine timing.

Refer to the illustration.

	Degree
Injection Timing B.T.D.C	104

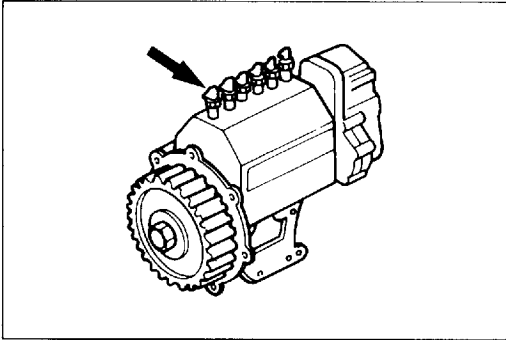

## Important Operations

### 9. Injection Pump with Injection Pump Gear

Use the shipping plugs (or something similar) to seal the injection pump delivery valve ports. This will prevent the entry of foreign material.

### Flange Mounted Injection Pump Removal

- 1) Remove the injection pump flange bolts.
- 2) Pull the injection pump with the injection pump drive gear free.

Refer to the illustration.

## PISTON AND CONNECTING ROD DISASSEMBLY STEPS

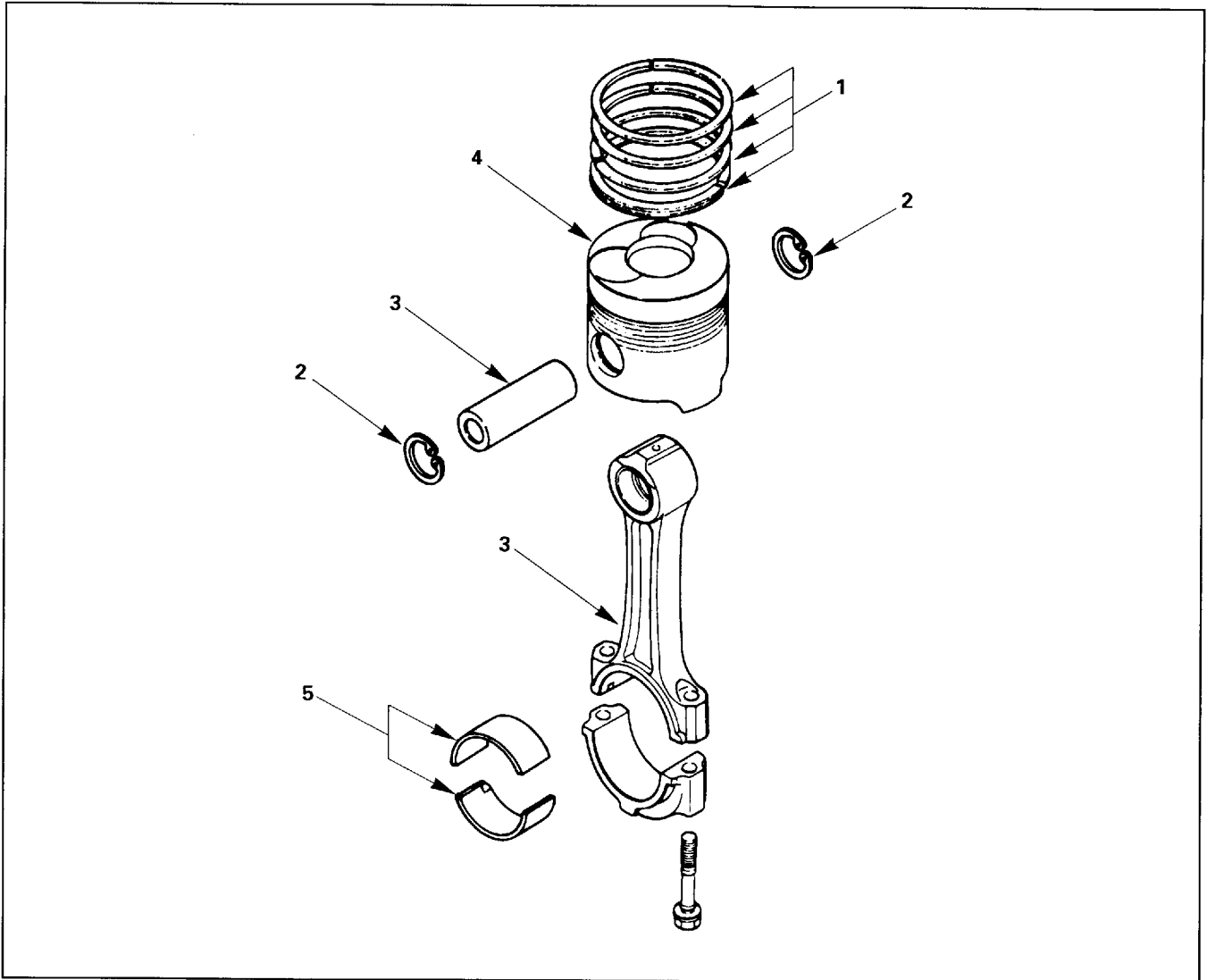

### Disassembly Steps

- ▲ 1. Piston rings
- ▲ 2. Snap ring
- ▲ 3. Piston pin and connecting rod
- 4. Piston
- 5. Connecting rod bearing

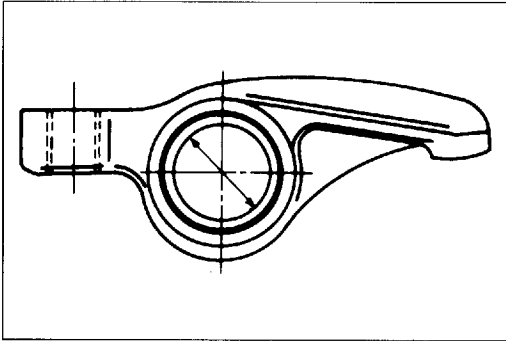

**Rocker Arm Shaft and Rocker Arm Clearance**

1. Use a vernier caliper to measure the rocker arm bushing inside diameter.

mm (in)

	Standard	Limit
Rocker Arm Bushing Inside Diameter	19.01–19.03 (0.749–0.750)	19.05 (0.751)

2. Measure the rocker arm shaft outside diameter.

Replace either the rocker arm or the rocker arm shaft if the clearance exceeds the specified limit.

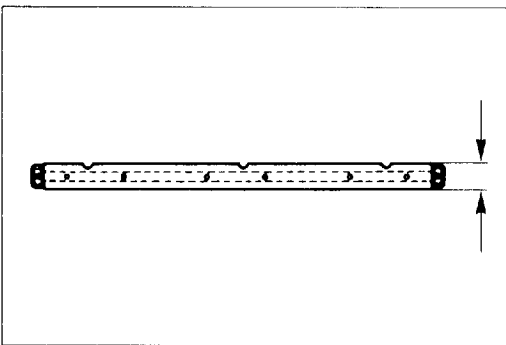

mm (in)

	Standard	Limit
Rocker Arm Bushing and Rocker Arm Shaft Clearance	0.01–0.05 (0.0004–0.0020)	0.2 (0.0079)

3. Check that the rocker arm oil port is free of obstructions.

If necessary, use compressed air to clean the rocker arm oil port.

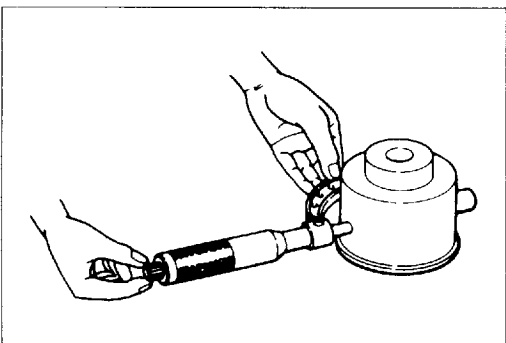

**IDLER GEAR AND IDLER GEAR SHAFT**

1. Use a micrometer to measure the idler gear shaft outside diameter.

If measured diameter exceeds specified limit, replace the idler gear shaft.

mm (in)

	Standard	Limit
Idler Gear Shaft Outside Diameter	44.945–44.975 (1.769–1.771)	44.9 (1.768)

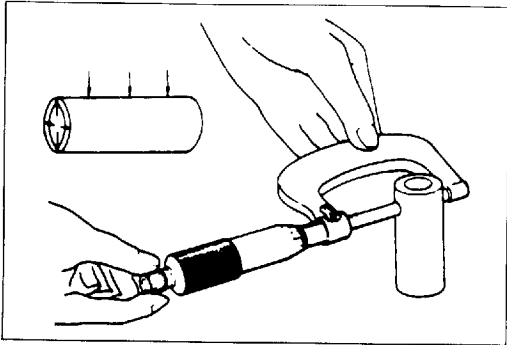

## PISTON PIN

### Piston Pin Outside Diameter



Use a micrometer to measure the piston pin outside diameter at several points.

If the measured piston pin outside diameter exceeds the specified limit, the piston pin must be replaced.

mm (in)

	Standard	Limit
Piston Pin Outside Diameter	35.000–35.005 (1.3780–1.3781)	34.95 (1.3760)

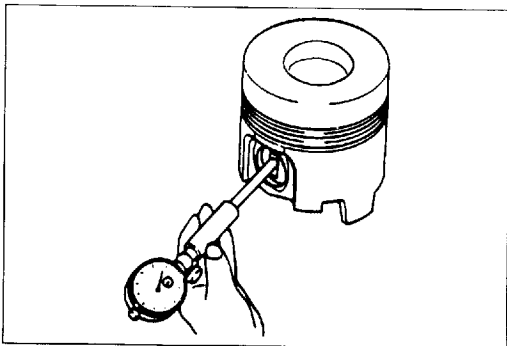

### Piston Pin and Piston Clearance



Use an inside dial indicator to measure the piston pin hole.

mm (in)

	Standard
Piston Pin Hole Diameter	35.010–35.018 (1.3783–1.3787)

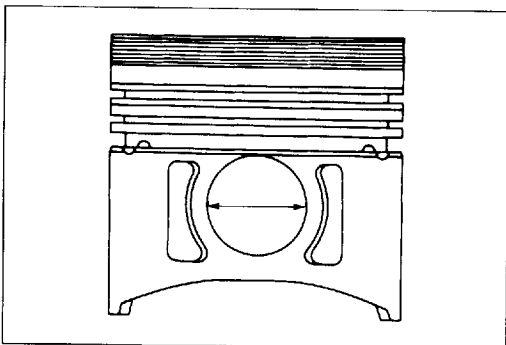

### Piston Pin and Piston Pin Hole Clearance

Determine the clearance between the piston pin and the piston pin hole by calculating the difference between the piston pin hole diameter and the piston pin outside diameter.

mm (in)

	Standard	Limit
Piston Pin and Piston Pin Hole Clearance	0.010–0.023 (0.00039–0.0009)	0.050 (0.00197)

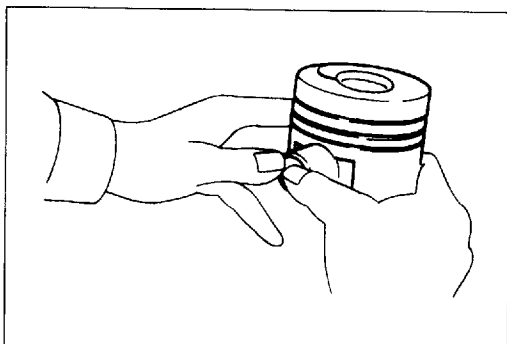

If an inside dial indicator is not available, use the following procedure to check the piston pin fit.

1. Use a piston heater to heat the piston to approximately 60°C (140°F).
2. Push strongly against the piston pin with your thumbs.

The piston pin fitting should feel tight.

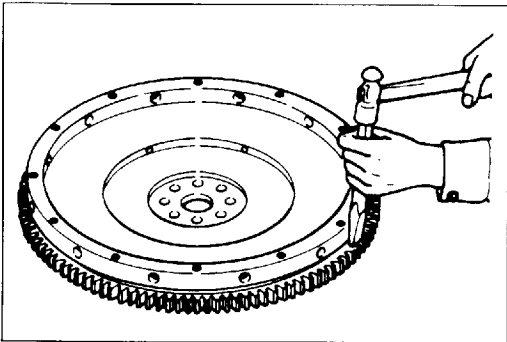

## FLYWHEEL

### Ring Gear Inspection

Inspect the ring gear.

If the ring gear teeth are broken or excessively worn, the ring gear must be replaced.

### Ring Gear Replacement

#### Ring Gear Removal

Strike around the edges of the ring gear with a hammer and chisel to remove it.



#### Ring Gear Installation

1. Heat the ring gear evenly with a gas-burner to invite thermal expansion.

Do not allow the temperature of the ring gear to exceed 200°C (390°F).

2. Use a hammer to install the ring gear when it is sufficiently heated.

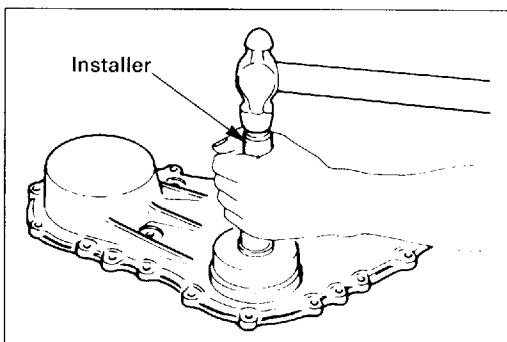
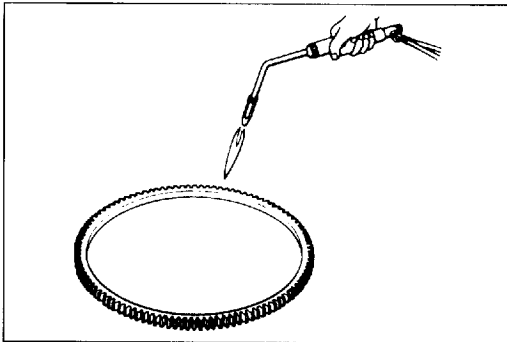

## TIMING GEAR CASE COVER

### Crankshaft Front Oil Seal Replacement

#### Removal



Use an adapter and a hammer to remove the crankshaft front end oil seal.

#### Installation



Use the crankshaft front oil seal installer to install the crankshaft front oil seal.



Crankshaft Front Oil Seal Installer: 9-8522-0034-0

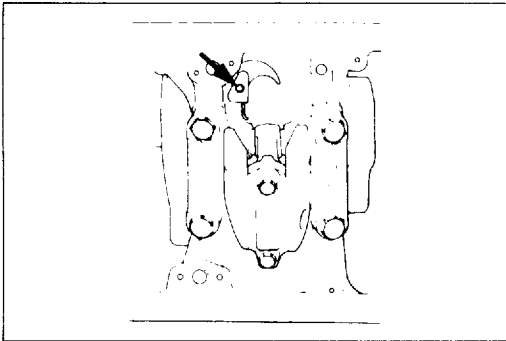

**Important Operations**



**1. Oil Jet**

Install the oil jets taking care not to damage the oil jet nozzles.

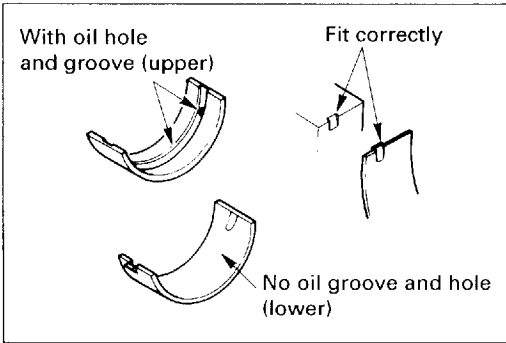

N·m (kgf·m/lb.ft)

Oil Jet Torque	16-25 (1.6-2.6/12-19)
----------------	-----------------------



**2. Crankshaft Bearing (Upper Half)**



**5. Crankshaft Bearing (Lower Half) and Crankshaft Bearing Cap**

The Crankshaft Bearing Configuration

	With Oil Groove	Without Oil Groove
Bearing Upper Half	All Upper Halves	—
Bearing Lower Half	—	All Lower Halves

Take care not to misinstall the bearing halves.

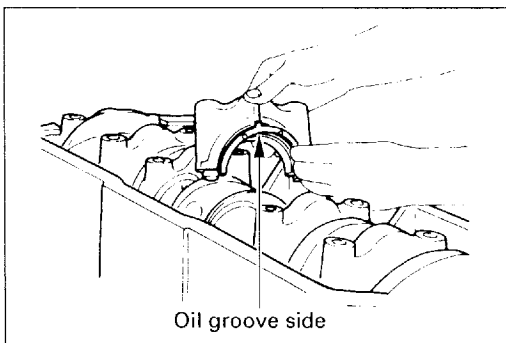

**4. Thrust Bearing**

Install the thrust bearings with the oil groove side facing the crankshaft sliding face.

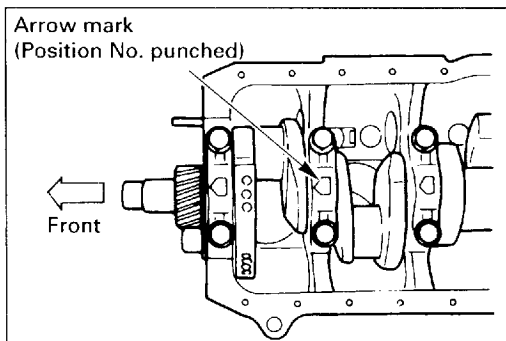

**5. Crankshaft Bearing Cap**

- 1) Lubricate the bearing cap bolts with engine oil.
- 2) Install the bearing caps to the crankshaft.

The arrow mark must be pointing to the front of the engine.

- 3) Tighten the bearing cap bolts to the specified torque a little at a time in the numerical order shown in the illustration.

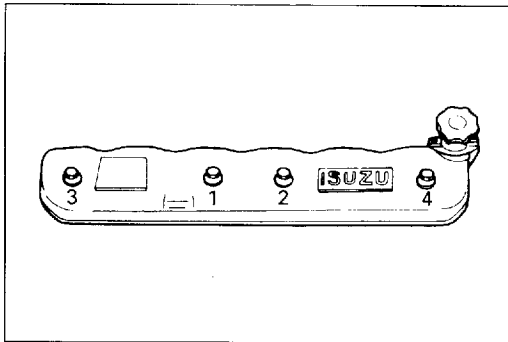

**Important Operations**

**1. Cylinder Head Cover**

- 1) Check that the rocker arms, the rocker arm shafts, and the valve springs are thoroughly lubricated with engine oil.

If required, relubricate these parts.

- 2) Place the cylinder head cover gasket on the cylinder head cover.

Check the head cover gasket for looseness.

- 3) Tighten the cylinder head cover bolts to the specified torque a little at a time in the sequence shown in the illustration.



N·m (kgf·m/lb.ft)

Cylinder Head Cover Bolt Torque	7.8 – 9.8 (0.8 – 1.0/5.8 – 7.2)
---------------------------------	---------------------------------



**4. Fan Belt**

Adjust the fan belt tension.

Refer to MAINTENANCE for the fan belt tension adjustment.

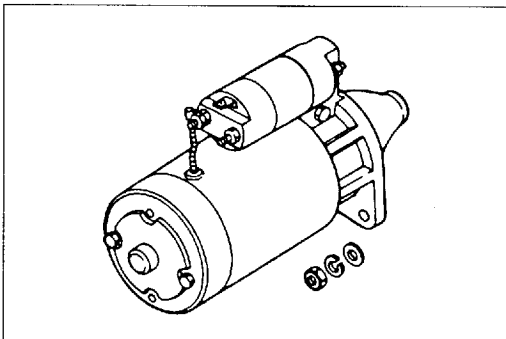

**5. Starter**

Install the starter to the flywheel housing and tighten the bolts to the specified torque.

N·m (kgf·m/lb.ft)

Starter Fixing Bolts Torque	75 – 91 (7.6 – 9.3/55 – 67)
-----------------------------	-----------------------------

# OIL PUMP



## DISASSEMBLY

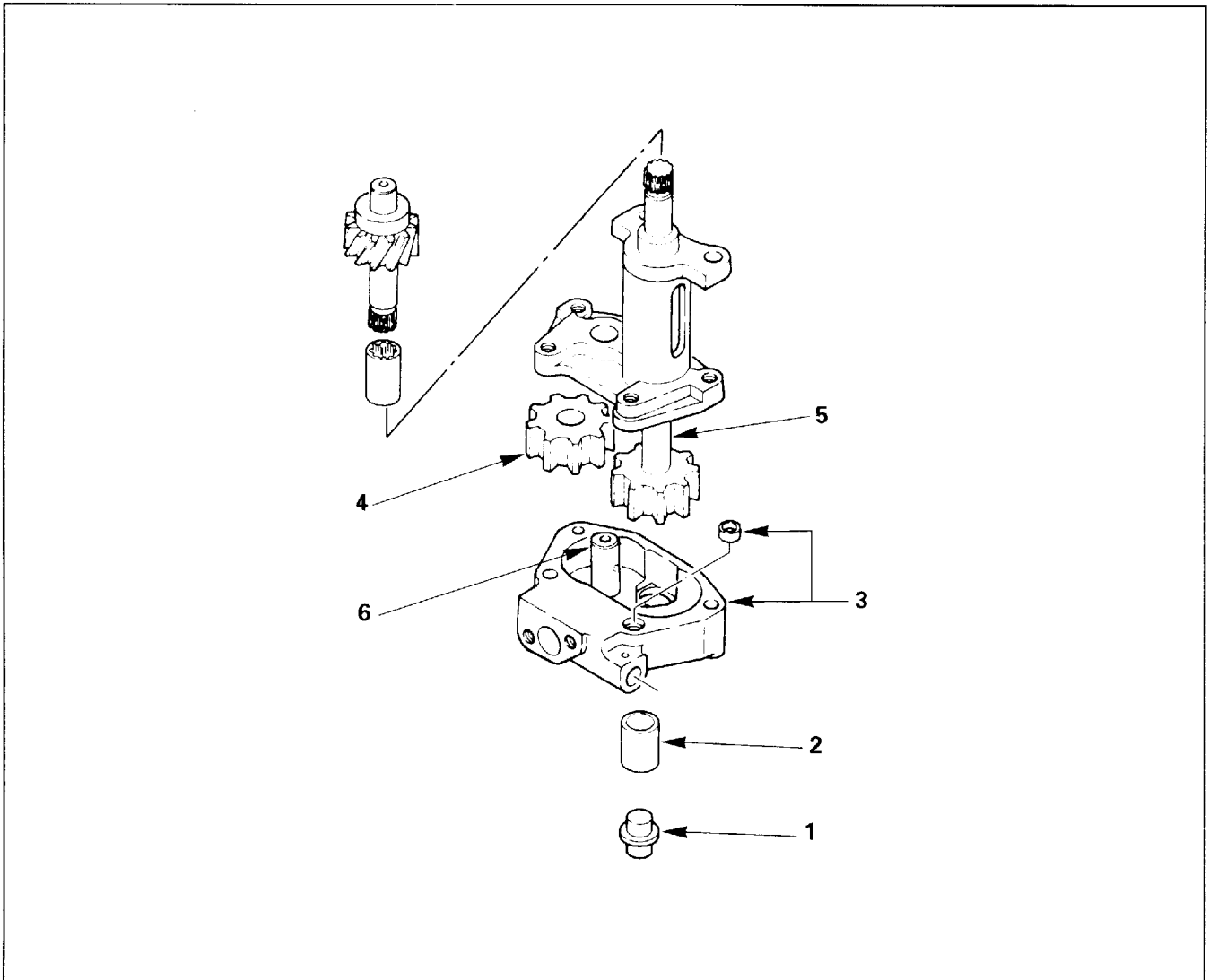

### Disassembly Steps

1. Strainer
2. Suction pipe
3. Cover and dowel
4. Driven gear
5. Drive shaft and gear
6. Driven gear shaft

# INJECTION NOZZLE



## DISASSEMBLY

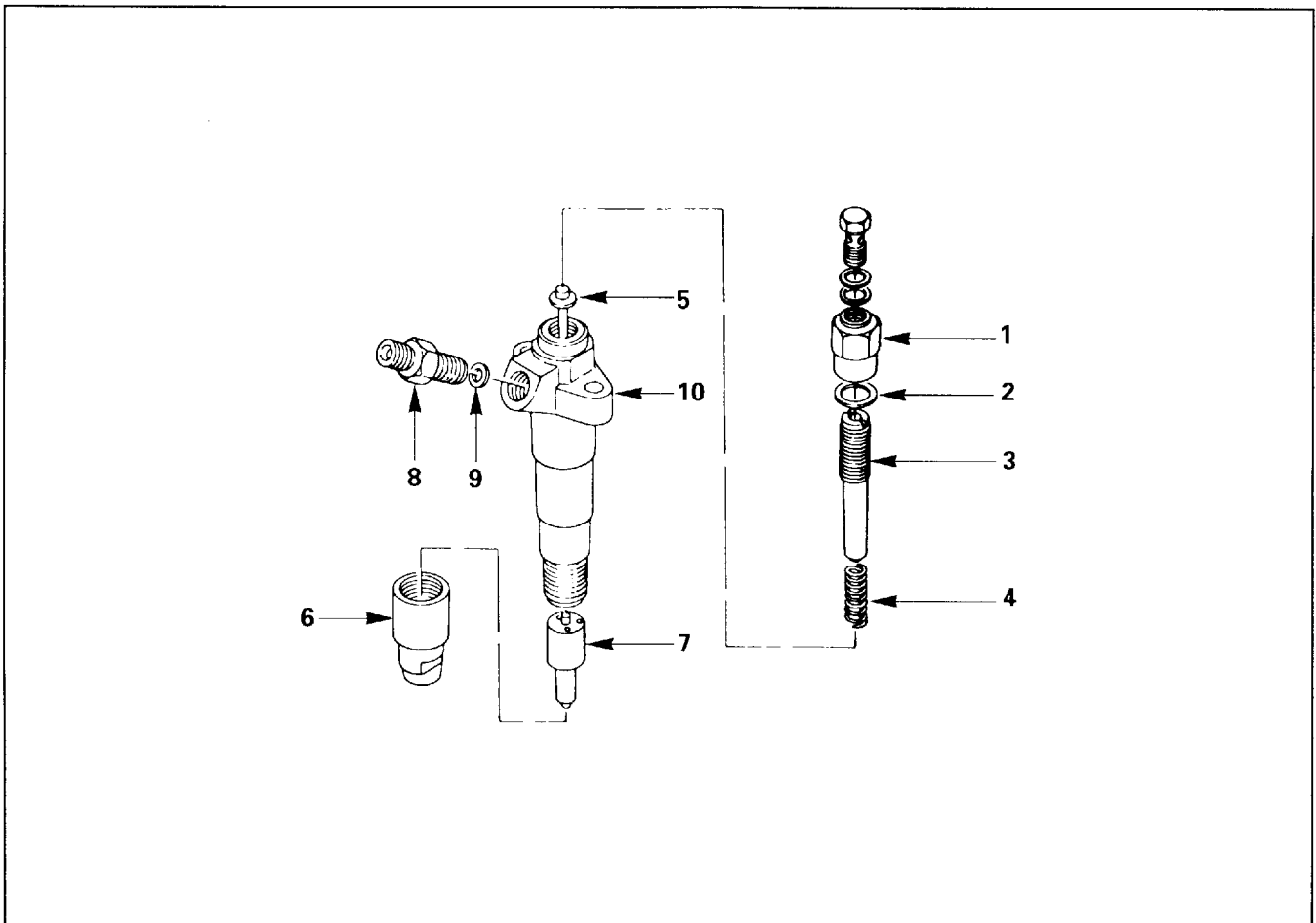

### Disassembly Steps

- |                           |                             |
|---------------------------|-----------------------------|
| 1. Nozzle holder cap nut  | 6. Retaining nut            |
| 2. Cap nut gasket         | ▲ 7. Injection nozzle       |
| 3. Nozzle adjusting screw | 8. Injection pipe connector |
| 4. Push rod spring        | 9. Connector gasket         |
| 5. Nozzle holder push rod | 10. Nozzle holder body      |

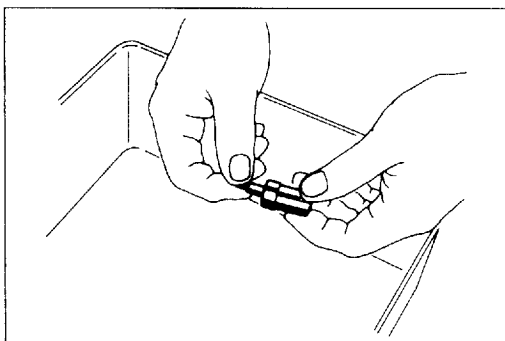

### Important Operation

#### 7. Nozzle

Remove the nozzle assembly from the nozzle body.  
Keep the parts separately to maintain the proper needle valve to body combination.

## TURBOCHARGER IDENTIFICATION

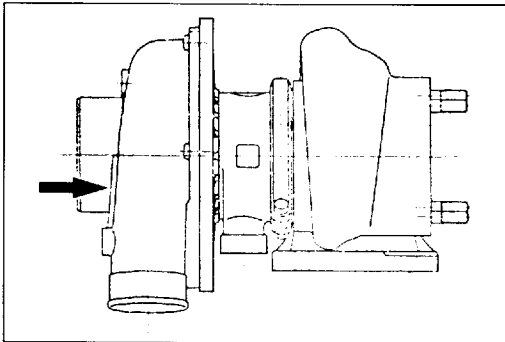

### IDENTIFICATION

The IHI Turbocharger nameplate gives the date of manufacture and other important information required to identify the unit when service inquiries or part orders are made.

The arrow in the illustration indicates the location of the Turbocharger nameplate.

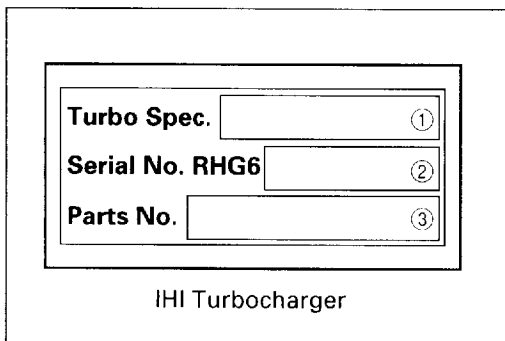

The turbocharger nameplate has the following information stamped on it. Refer to the illustration at the left.

- (1) Turbo Specification Number, Production Year and Month
- (2) Production Date, Daily Serial Number
- (3) ISUZU Parts Number

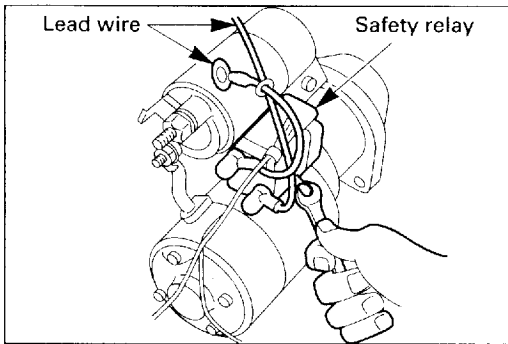

**DISASSEMBLY**

**Removal of Safety Relay**

Remove the nut M10 (17 mm/0.669 in) and bolt M5 (8 mm/0.315 in) from the magnetic switch.

Then remove 2 pieces of the bolt M6 (10 mm/0.393 in).

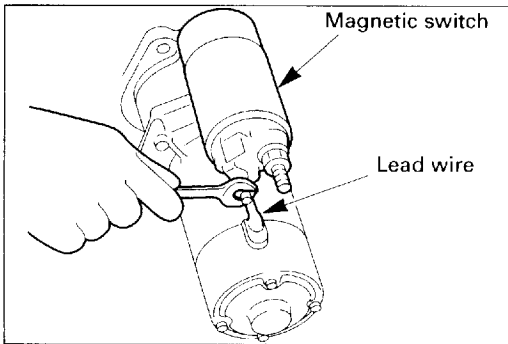

**Disconnection of Lead Wire**

Remove the nut M10 (17 mm/0.669 in) from the magnetic switch and disconnect the lead wire.

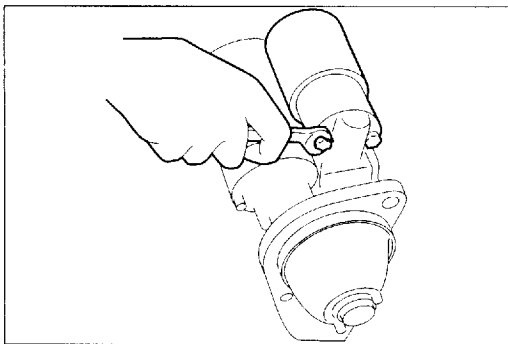

**Removal of Magnetic Switch**

Remove 2 pieces of the bolts M6 (10 mm/0.393 in).

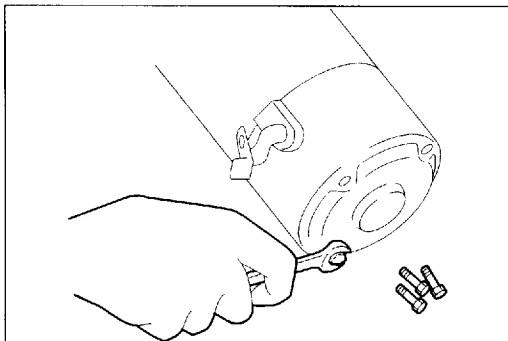
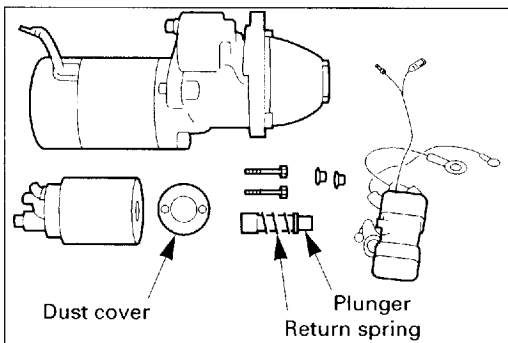

**Removal of Rear Cover**

Remove 2 pieces of the brush holder tightening screw M4 and then remove 2 pieces of the through bolt M6 (10 mm/0.393 in).

Then, remove the rear cover and the yoke using a straight screwdriver.

## ALTERNATOR IDENTIFICATION

The alternator identification plate is attached to the alternator rear bracket. The ISUZU part number, the manufacturer's code number, and other important information are stamped on the plate.

Refer to the identification plate together with the "Main Data and Specifications" Tables and accompanying charts in this Manual when requesting service assistance from a qualified electrical repair shop.

If you are unable to locate the data applicable to your engine, please contact ISUZU MOTORS LIMITED through your machine supplier.

### mitsubishi IDENTIFICATION PLATE

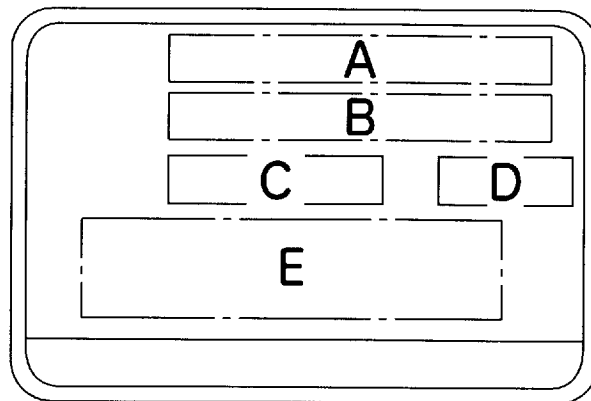

- A: Isuzu part number
- B: Manufacturer's short type name
- C: System voltage output
- D: Manufacturer's lot no.
- E: Bar code

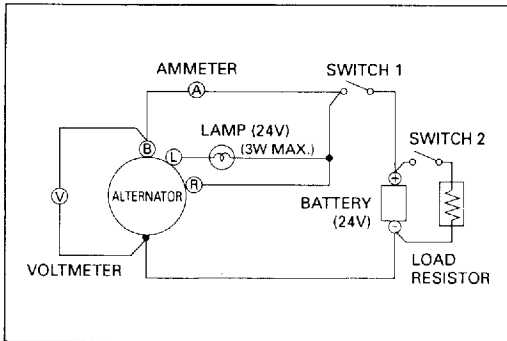

## BENCH TEST

To check the alternator on a test bench, proceed as follows:

### Regulated Voltage Test

- (1) Make connections as shown in Fig.

Use a 0–100 ampere scale ammeter and a 0–30 volt scale voltmeter.

Use a variable load resistor of capacity 0–50 ampere minimum.

- (2) Close switch 1. Open switch 2.

Lamp should light. If the lamp does not light, check voltage at terminal-L.

When the voltage is nearly to battery voltage check the alternator.

When the voltage is low the lamp or relational wiring is open circuit.

- (3) Slowly increase the alternator speed.

Be sure the lamp goes out until the alternator speed reaches to approx.  $1300 \text{ min}^{-1}$ .

Observe the voltage.

If the voltage is uncontrolled with speed and increases above 30V, a defective IC regulator is suspected.

If the voltage does not increase higher than battery voltage, this means alternator does not generate.

Recheck the alternator.

- (4) Increase the alternator speed to approx.  $500 \text{ min}^{-1}$  and take the ammeter reading.

If the ammeter reading is 5A or less, take the voltmeter reading without changing the alternator speed (approx.  $500 \text{ min}^{-1}$ ).

The reading is the regulated voltage.

If the ammeter reading is more than 5A, continue to charge battery until the reading falls to less than 5A or replace the battery with a fully charged one.

If the regulated voltage does not meet specifications limits, it will have to be replaced.

## UNSTABLE LOW IDLING

Checkpoint	Trouble Cause	Remedy
Continued from the previous page		
OK		
Injection pump	Defective governor lever operation	Repair or replace the governor lever
Injection pump	Broken plunger spring	Replace the plunger spring
Injection pump	Worn plunger	Replace the plunger assembly
Injection pump	Worn camshaft	Replace the camshaft
Injection pump	Worn roller tappet	Replace the roller tappet
OK		
Valve clearance	Valve clearance improperly adjusted	Adjust the valve clearance
OK		
Compression pressure	Blown out cylinder head gasket Worn cylinder liner Piston ring sticking or broken Improper seating between the valve and the valve seat	Replace the related parts

## DARK EXHAUST SMOKE

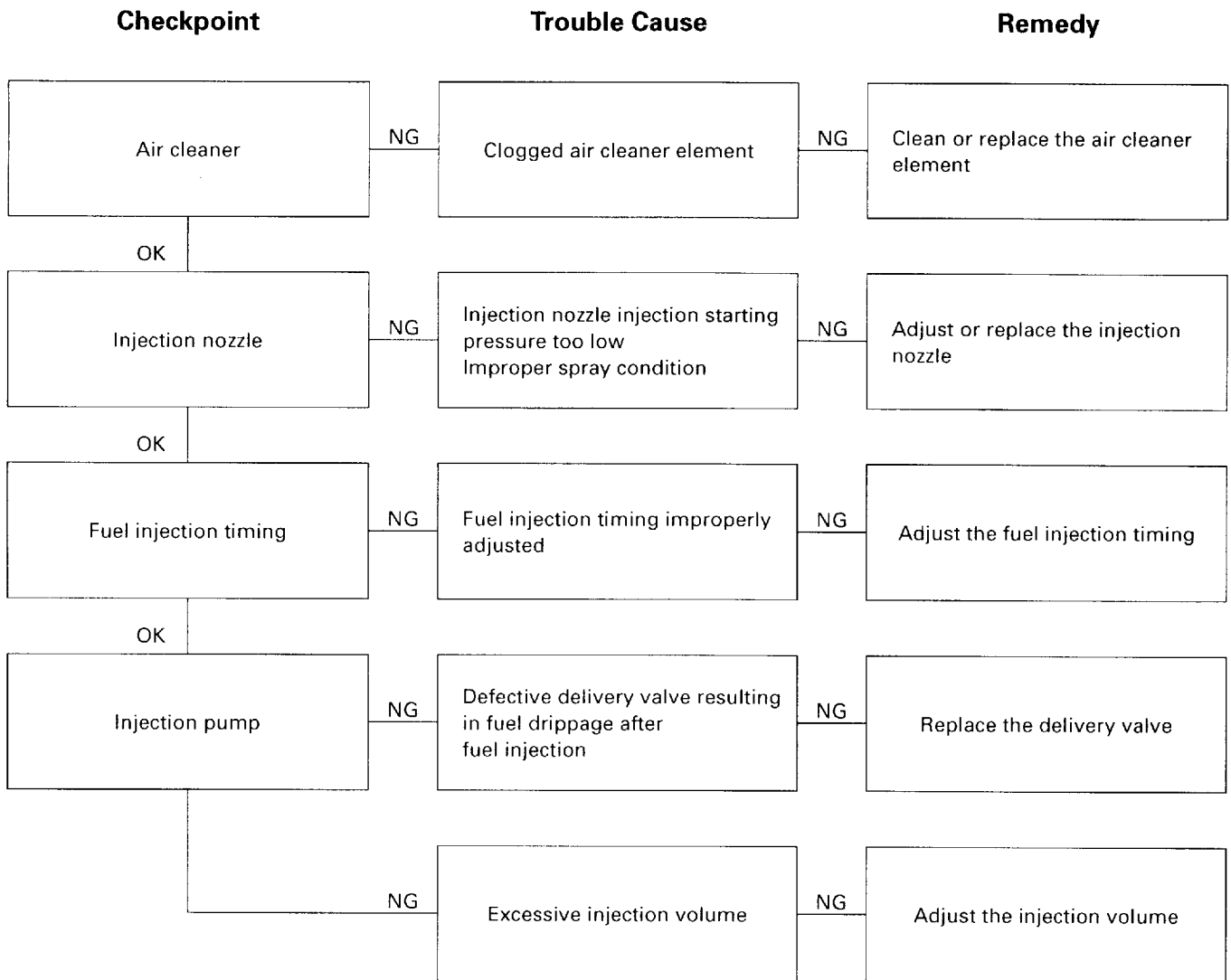

## SECTION 13

**REPAIR STANDARDS****GENERAL RULES**

1. These tables provide standards relating the repair of the following diesel engine;  
Model AA-6BG1TRA
2. These Repair Standards are based on inspection items, together with dimensions, assembly standards, limit values, and repair procedures.
  - (1) Nominal dimensions are the standard production values.
  - (2) Assembly standards considered to be the values used as objectives during the assembly procedures which follow repairs; as a result, they may be somewhat at variance with the assembly dimensions of a new engine.
  - (3) Limit values refer to the measured values resulting from wear, etc., beyond which a part must not be used. If a measured value falls beyond the limit value, the part involved must be repaired or replaced.
  - (4) "Repair Procedures" indicates normal repair methods.
  - (5) Unless otherwise stated, the unit of numerical values in tables should be taken to refer to millimeters. mm (in).
3. Explanation of Terms Used in Tables
  - (1) The dimension of "wear" refers to the difference between the dimensions of a part which is not worn (or the "nominal dimension" of a part without wear) and the dimension of the part suffering from the most wear (the dimension of the worn part).
  - (2) Uneven wear means the difference between the maximum and minimum wear values.
4. When repairs are requested on the overall engine, first perform bench tests to determine what parts require repairs, then perform the minimum disassembly and repairs required to correct the problems. When repairs on a specific engine part are requested, repairs to be made in reference to the relevant items in accordance with the repair standards listed in this manual.



Major Category	Name of Part	Inspection Item	Nominal Dimension	Assembly Standard Value	Limit	Repair Procedure	Comments
Valve System	Valves	Valve clearance (inlet & exhaust) (cold)		0.4 (0.016)		Adjust	
		Clearance between rocker arm shaft and rocker arm		0.01 – 0.05 (0.0004 – 0.002)	0.2 (0.0079)	Replace bushing or shaft	
		Rocker arm shaft wear		18.98 – 19.00 (0.747 – 0.748)	Dia. 18.85 (0.742)	Replace	
Intake System	Air cleaner	Air cleaner element condition					Special order item from manufacturer

SECTION 14

CONVERSION TABLE

TABLE OF CONTENTS

ITEM	PAGE
LENGTH .....	14- 2
AREA .....	14- 3
VOLUME .....	14- 3
MASS .....	14- 5
PRESSURE .....	14- 6
TORQUE .....	14- 7
TEMPERATURE .....	14- 8

LENGTH

MILLIMETERS TO INCHES

mm	in.	mm	in.	mm	in.	mm	in.
1	0.0394	26	1.0236	51	2.0079	76	2.9921
2	0.0787	27	1.0630	52	2.0472	77	3.0315
3	0.1181	28	1.1024	53	2.0866	78	3.0709
4	0.1575	29	1.1417	54	2.1260	79	3.1102
5	0.1969	30	1.1811	55	2.1654	80	3.1496
6	0.2362	31	1.2205	56	2.2047	81	3.1890
7	0.2756	32	1.2598	57	2.2441	82	3.2283
8	0.3150	33	1.2992	58	2.2835	83	3.2677
9	0.3543	34	1.3386	59	2.3228	84	3.3071
10	0.3937	35	1.3780	60	2.3622	85	3.3465
11	0.4331	36	1.4173	61	2.4016	86	3.3858
12	0.4724	37	1.4567	62	2.4409	87	3.4252
13	0.5118	38	1.4961	63	2.4803	88	3.4646
14	0.5512	39	1.5354	64	2.5197	89	3.5039
15	0.5906	40	1.5748	65	2.5591	90	3.5433
16	0.6299	41	1.6142	66	2.5984	91	3.5827
17	0.6693	42	1.6535	67	2.6378	92	3.6220
18	0.7087	43	1.6929	68	2.6772	93	3.6614
19	0.7480	44	1.7323	69	2.7165	94	3.7008
20	0.7874	45	1.7717	70	2.7559	95	3.7402
21	0.8268	46	1.8110	71	2.7953	96	3.7795
22	0.8661	47	1.8504	72	2.8346	97	3.8189
23	0.9055	48	1.8898	73	2.8740	98	3.8583
24	0.9449	49	1.9291	74	2.9134	99	3.8976
25	0.9843	50	1.9685	75	2.9528	100	3.9370

101	3.9764	111	4.3701	121	4.7638	131	5.1575
102	4.0157	112	4.4094	122	4.8031	132	5.1969
103	4.0551	113	4.4488	123	4.8425	133	5.2362
104	4.0945	114	4.4882	124	4.8819	134	5.2756
105	4.1339	115	4.5276	125	4.9213	135	5.3150
106	4.1732	116	4.5669	126	4.9606	136	5.3543
107	4.2126	117	4.6063	127	5.0000	137	5.3937
108	4.2520	118	4.6457	128	5.0394	138	5.4331
109	4.2913	119	4.6850	129	5.0787	139	5.4724

INCHES TO MILLIMETERS

in.	mm	in.	mm	
	1/64	0.3969	33/64	13.0969
	1/32	0.7938	17/32	13.4938
	3/64	1.1906	35/64	13.8906
1/16		1.5875	9/16	14.2875
	5/64	1.9844	37/64	14.6844
	3/32	2.3813	19/32	15.0813
	7/64	2.7781	39/64	15.4781
1/8		3.1750	5/8	15.8750
	9/64	3.5719	41/64	16.2719
	5/32	3.9688	21/32	16.6688
	11/64	4.3656	43/64	17.0656
3/16		4.7625	11/16	17.4625
	13/64	5.1594	45/64	17.8594
	7/32	5.5563	23/32	18.2563
	15/64	5.9531	47/64	18.6531
1/4		6.3500	3/4	19.0500
	17/64	6.7469	49/64	19.4469
	9/32	7.1438	25/32	19.8438
	19/64	7.5406	51/64	20.2406
5/16		7.9375	13/16	20.6375
	21/64	8.3344	53/64	21.0344
	11/32	8.7313	27/32	21.4313
	23/64	9.1281	55/64	21.8281
3/8		9.5250	7/8	22.2250
	25/64	9.9219	57/64	22.6219
	13/32	10.3188	29/32	23.0188
	27/64	10.7156	59/64	23.4156
7/16		11.1125	15/16	23.8125
	29/64	11.5094	61/64	24.2094
	15/32	11.9063	31/32	24.6063
	31/64	12.3031	63/64	25.0031
1/2		12.7000	1	25.4000

CLICK HERE TO **DOWNLOAD** THE COMPLETE MANUAL

- Thank you very much for reading the preview of the manual.
- You can download the complete manual from: [www.heydownloads.com](http://www.heydownloads.com) by clicking the link below



- Please note: If there is no response to CLICKING the link, please download this PDF first and then click on it.

CLICK HERE TO **DOWNLOAD** THE COMPLETE MANUAL