

PART NO. TTLBE50-EN-00

HITACHI

Reliable solutions

Technical Manual

Troubleshooting

ZX170W-6

Wheeled Excavator

ZX170W-6 WHEELED EXCAVATOR TECHNICAL MANUAL TROUBLESHOOTING

 **Hitachi Construction Machinery Co., Ltd.**

URL:<http://www.hitachi-c-m.com>

PRINTED IN JAPAN (K) 2016, 12

TTLBE50-EN-00

Service Manual consists of the following separate Part No.

Technical Manual (Operational Principle)	: Vol. No.TOLBE50-EN
Technical Manual (Troubleshooting)	: Vol. No.TTLBE50-EN
Workshop Manual	: Vol. No.WLBE50-EN
Engine Manual	: Vol. No.ETDC150-EN, EWDC150-EN

CLICK HERE TO **DOWNLOAD** THE COMPLETE MANUAL

- Thank you very much for reading the preview of the manual.
- You can download the complete manual from: www.heydownloads.com by clicking the link below



- Please note: If there is no response to CLICKING the link, please download this PDF first and then click on it.

CLICK HERE TO **DOWNLOAD** THE COMPLETE MANUAL

SAFETY

Recognize Safety Information

- These are the **SAFETY ALERT SYMBOLS**.
 - When you see these symbols on your machine or in this manual, be alert to the potential for personal injury.
 - Follow recommended precautions and safe operating practices.



SA-2644

Understand Signal Words

- On machine safety signs, signal words designating the degree or level of hazard - **DANGER**, **WARNING**, or **CAUTION** - are used with the safety alert symbol.
 - **DANGER** indicates an imminently hazardous situation which, if not avoided, will result in death or serious injury.
 - **WARNING** indicates a potentially hazardous situation which, if not avoided, could result in death or serious injury.
 - **CAUTION** indicates a potentially hazardous situation which, if not avoided, may result in minor or moderate injury.
 - **DANGER or WARNING safety signs** are located near specific hazards. General precautions are listed on **CAUTION safety signs**.
 - Some safety signs are occasionally used on this machine that do not use any of the designated signal words mentioned above after the safety alert symbol.
- **CAUTION** also calls attention to safety message in this manual.
- To avoid confusing machine protection with personal safety messages, a signal word **IMPORTANT** indicates a situation which, if not avoided, could result in damage to the machine.
-  **NOTE**: Indicates an additional explanation for a piece of information.



IMPORTANT



SA-1223

SAFETY

Investigate Job Site Beforehand

- When working at the edge of an excavation or on a road shoulder, the machine could tip over, possibly resulting in serious injury or death.
 - Investigate the configuration and ground conditions of the job site beforehand to prevent the machine from falling and to prevent the ground, stockpiles or banks from collapsing.
 - Make a work plan. Use machines appropriate to the work and job site.
 - Reinforce ground, edges and road shoulders as necessary. Keep the machine well back from the edges of excavations and road shoulders.
 - When working on an incline or on a road shoulder, employ a signal person as required.
 - Confirm that your machine is equipped with a FOPS cab before working in areas where the possibility of falling stones or debris exist.
 - When the ground footing is weak, reinforce the ground before starting work.
 - When working on frozen ground, be extremely alert. As ambient temperatures rise, footing becomes loose and slippery.
 - Beware the possibility of fire when operating the machine near flammable materials such as dry grass.



SA-085

SAFETY

Object Handling

- If a lifted load should fall, any person nearby may be struck by the falling load or may be crushed underneath it, resulting in serious injury or death.
 - When using the machine for craning operations, be sure to comply with all local regulations.
 - Do not use damaged chains or frayed cables, slings, or ropes.
 - Before craning, position the upperstructure with the travel motors at the rear.
 - Move the load slowly and carefully. Never move it suddenly.
 - Keep all persons well away from the load.
 - Never move a load over a person's head.
 - Do not allow anyone to approach the load until it is safely and securely situated on supporting blocks or on the ground.
 - Never attach a sling or chain to the bucket teeth. They may come off, causing the load to fall.

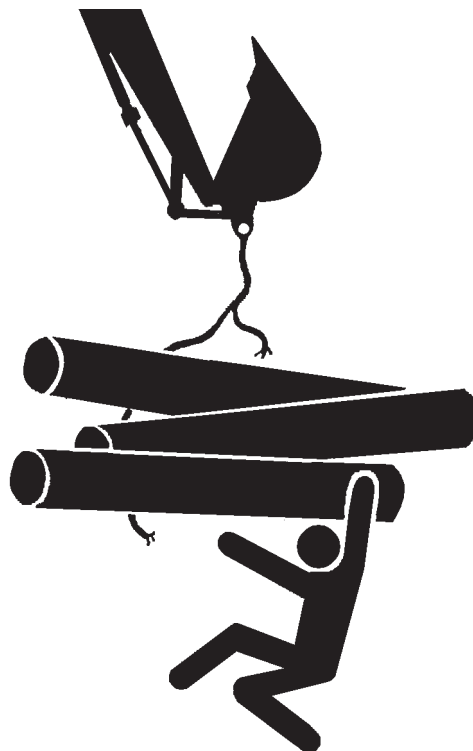

SA-014

Protect Against Flying Debris

- If flying debris hit eyes or any other part of the body, serious injury may result.
 - Guard against injury from flying pieces of metal or debris; wear goggles or safety glasses.
 - Keep bystanders away from the working area before striking any object.
 - Always close the front windows, doors, door windows and the overhead window when operating the machine.

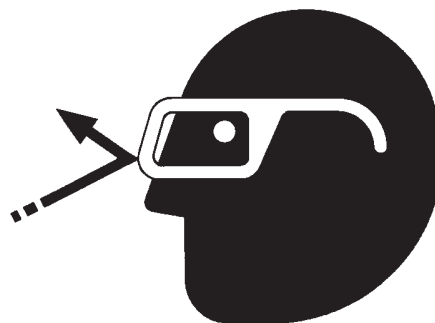

SA-432

SAFETY

Evacuating in Case of Fire

- If a fire breaks out, evacuate the machine in the following way:
 - Stop the engine by turning the key switch to the OFF position if there is time.
 - Use a fire extinguisher if there is time.
 - Exit the machine.
- In an emergency, if the cab door or front window can not be opened, break the front or rear window pane with the emergency evacuation hammer to escape from the cab. Refer to the explanation pages on the Emergency Evacuation Method in the operator's manual.



SA-393



SS-1510

Beware of Exhaust Fumes

- Prevent asphyxiation. Engine exhaust fumes can cause sickness or death.
 - If you must operate in a building, be sure there is adequate ventilation. Either use an exhaust pipe extension to remove the exhaust fumes or open doors and windows to bring enough outside air into the area.
 - White smoke may be generated during the aftertreatment device regeneration. Do not attempt to do aftertreatment device manual regeneration in a badly ventilated indoors.

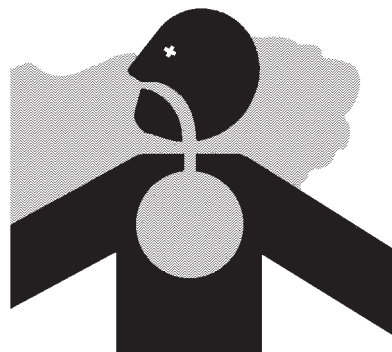

SA-016

SAFETY

Notes on Protection of Operator's Station when the Machine Rolls Over

The cab corresponds to the structure to protect the operator by absorbing impact energy when the machine rolls over (Roll-Over Protective Structure (ROPS)).

However, when modifying the machine or installing a special attachment causing the machine mass to exceed the maximum operating mass described in the ROPS certification, the cab cannot fulfill its protective function, possibly causing serious injury or death.

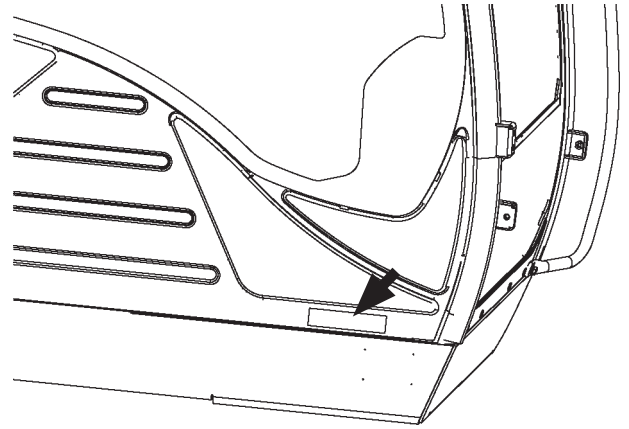

SS-3636

In order to safeguard the protective structure, follow the instructions below.

- Consult your authorized dealer before welding parts or drilling a hole on the cab, which possibly reduces the cab strength.
- Be sure to always fasten the seat belt when operating the machine. If the machine rolls over without operator fastening the seat belt, the operator may become injured, may be thrown out from the cab and/or may become crushed under the machine even though the cab has the protective structure.

The ROPS certification is valid under the following conditions.

- The machine mass is lower than the maximum operating mass described in the ROPS certification.
- The ROPS is properly installed.
- No modification is made to the ROPS.
- The ROPS is free from damage.

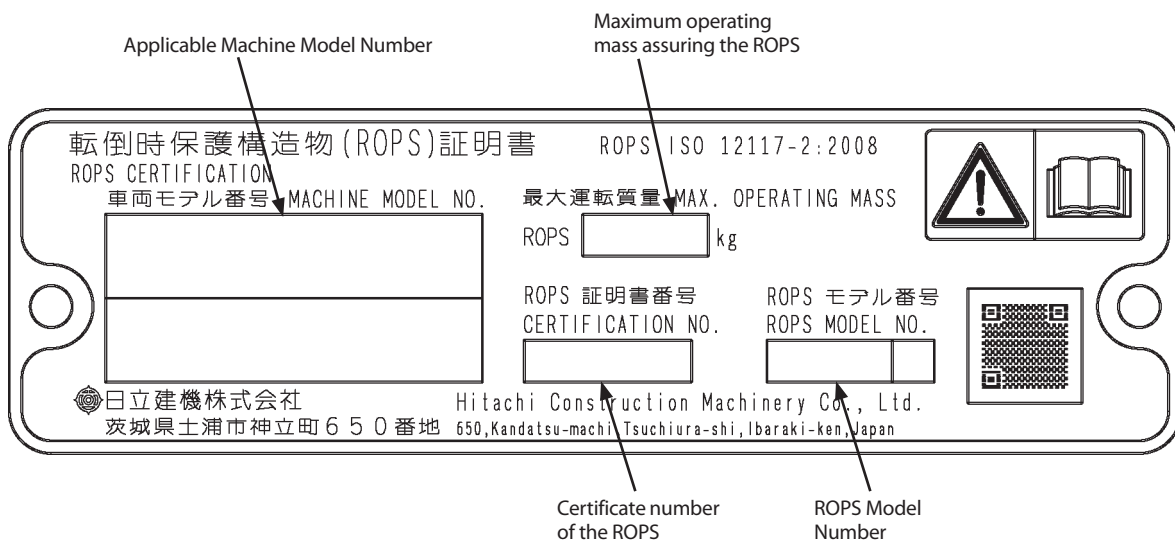

SS-3671

SECTION 4 OPERATIONAL PERFORMANCE TEST

Group 2 Standard

Performance Test Designation	Unit	Performance Standard	Remark	Reference Page
ENGINE COMPRESSION PRESSURE	MPa	3.04±0.2	Engine speed: 200 min ⁻¹	Refer to Engine Manual.
VALVE CLEARANCE (IN, EX)	mm	0.4	With the engine cold	Refer to Engine Manual.
LUBRICANT CONSUMPTION (Rated output)	mL/h	30 or less	Hour meter: 2000 hours or less	T4-3-5
TRAVEL SPEED	km/h			T4-4-1
Fast Speed Mode		Travel speed 35 km/h spec.: 35.0 ^{+1.0} _{-3.0} Travel speed 20 km/h spec.: 20.0±2.0	Engine speed control mode selection switch: Pedal mode, Travel mode switch: Fast	
Slow Speed Mode		Travel speed 35 km/h spec.: 8.6±0.5 Travel speed 20 km/h spec.: 4.9±0.5	Engine speed control mode selection switch: Pedal mode, Travel mode switch: Slow	
Very Slow Speed		2.5±0.3	Engine speed control mode selection switch: Creeper mode	
Brake Function Check	N			T4-4-3
Service Brake		Tire: Locked		
Parking Brake		Tire: Locked		
Parking Brake Function Check	mm/5 min	0		T4-4-5
SWING SPEED	sec/3 rev	15.7±1.5	Bucket: empty	T4-4-6
SWING FUNCTION DRIFT CHECK	mm/180°	860 or less	Bucket: empty	T4-4-8
SWING MOTOR LEAKAGE	mm/5 min	0	Bucket: loaded Weight: 825 kg	T4-4-10
MAXIMUM SWINGABLE SLANT ANGLE	deg	18 or more	Bucket: loaded Weight: 825 kg	T4-4-12
SWING BEARING PLAY	mm	0.2 to 1.25	Allowable limit: 2.8	T4-4-14

SECTION 4 OPERATIONAL PERFORMANCE TEST

Group 2 Standard

Main Pump P-Q Diagram

- P-Q Control (Torque Control)
(Reference: Measured at Test Stand)
 - Rated Pump Speed: 2000 min⁻¹
 - Hydraulic Oil Temperature: 50±5 °C

 NOTE: Refer to T4-5-19.

Points on P-Q Line

	Delivery Pressure (P) MPa	Flow Rate (Q) L/min
A	4.9	236±3
B	12.7	[234]
C	17.6	185±6
D	20.6	[160]
E	25.5	130±6
F	34.3	86±10

[] is a reference value.

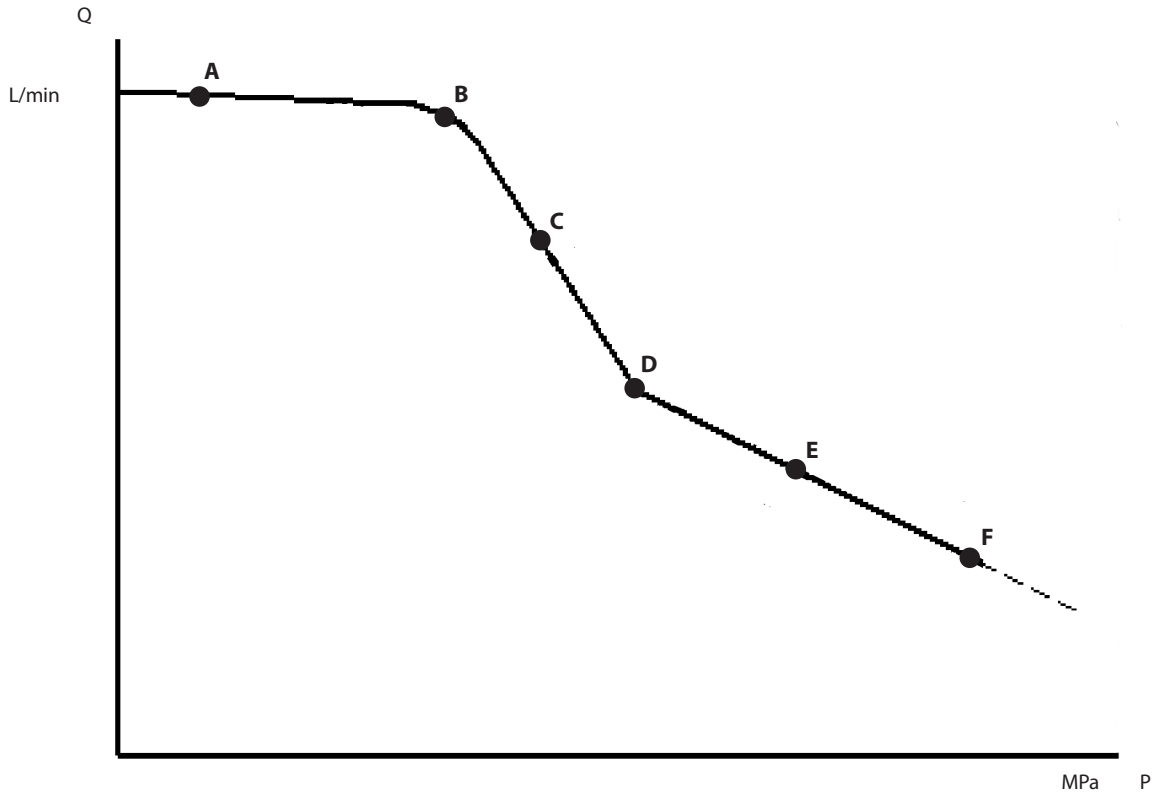

P- Delivery Pressure

Q- Flow Rate

T178-04-05-001

SECTION 4 OPERATIONAL PERFORMANCE TEST

Group 2 Standard

Item	Unit	Reference Value	Measured Value				Remark
			First	Second	Third	Average	
Tgt Pump 1 Displacement	cm ³						
Control lever in neutral		21					
Boom raise		10					When relieving
Boom lower		-					
Arm roll-in		19.5					When relieving
Arm roll-out		19.5					When relieving
Bucket roll-out		51.5					When relieving
Bucket roll-in		51.5					When relieving
Combined operation of boom raise, arm roll-in, and bucket roll-in		26					When relieving
Tgt Pump 2 Displacement	cm ³						
Control lever in neutral		21					
Boom raise		10					When relieving
Boom lower		-					
Arm roll-in		19.5					When relieving
Arm roll-out		19.5					When relieving
Bucket roll-out		21					When relieving
Bucket roll-in		21					When relieving
Combined operation of boom raise, arm roll-in, and bucket roll-in		26					When relieving

SECTION 4 OPERATIONAL PERFORMANCE TEST

Group 3 Engine Test

• Engine Speed Control Mode Selection Switch: Pedal Mode

Item	Accelerator Pedal	Power Mode Switch	Auto-Idle Switch	Work Mode	Test Conditions
Slow Idle Speed	Not depressed	PWR	OFF	Digging Mode	FNR switch: F position or R position, Brake switch: OFF or Axle lock position, Engine control dial: Slow Idle position
Fast Idle Speed (Working accelerator)	Fully depressed	PWR	OFF	Digging Mode	FNR switch: N position, Brake switch: OFF or Axle lock position, Auto axle lock switch: ON, Engine control dial: Fast Idle position
Fast Idle Speed (Travel relief operation)	Fully depressed	PWR	OFF	Digging Mode	Travel mode switch: Fast position, Brake switch: OFF or Axle lock position, *Raising the machine off the ground, Travel operation with the brake depressed

*Method raising the machine off the ground

As for the machine attached with the outrigger or blade in front and rear of the chassis, raise the machine off the ground by using the outrigger and blade.

⚠ CAUTION: Securely support the raised machine by using blocks.

As for the machine attached with the outrigger or blade only in rear of the chassis, raise the front wheels by lowering the front attachment as illustrated in the right.



TLAB-04-05-100

SECTION 4 OPERATIONAL PERFORMANCE TEST

Group 4 Machine Performance Test

Measurement:

1. Select the following conditions.

Engine Control Dial	Power Mode	Auto-Idle Switch	Work Mode	Brake Switch	Auto Axle Lock Switch
Fast Idle	PWR	OFF	Digging Mode	Work Brake or Axle Lock	ON

2. Operate the swing control lever to full stroke and swing the upperstructure.
3. Measure the time required to swing 3 turns when the swing speed is a constant speed.
4. Check the time in both clockwise and counterclockwise directions.
5. Repeat the measurement three times and calculate the mean values.

Evaluation:

Refer to Operational Performance Standard.

Remedy:

Refer to Troubleshooting B.

SECTION 4 OPERATIONAL PERFORMANCE TEST

Group 4 Machine Performance Test

- Measurement of the cycle time of the blade cylinder:
Raise the machine off the ground by using the front attachment. Keep the space to allow the move up and down blade.

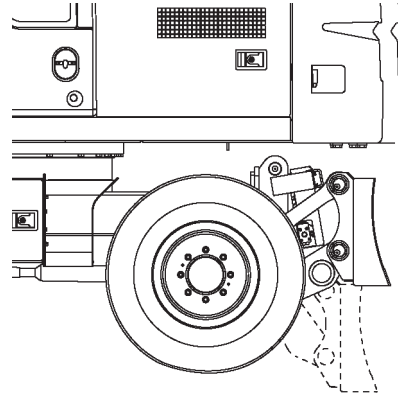

TCJB-04-04-001

 NOTE: The illustration shows the rear blade.

- Measurement of the cycle time of the outrigger cylinder:
Raise the machine off the ground by using the front attachment. Keep the space to allow the move up and down outrigger.

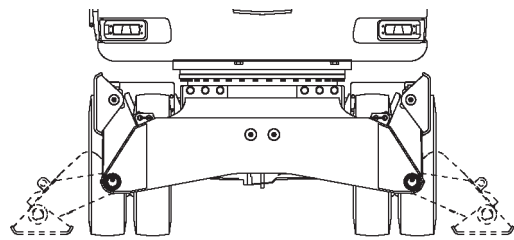

TCJB-04-04-002

 NOTE: The illustration shows the rear outrigger.

- Measurement of the cycle time of the positioning cylinder:
Fully extend the boom and bucket cylinders. Fully retract the arm cylinder.
2. Maintain the hydraulic oil temperature at 50 ± 5 °C.

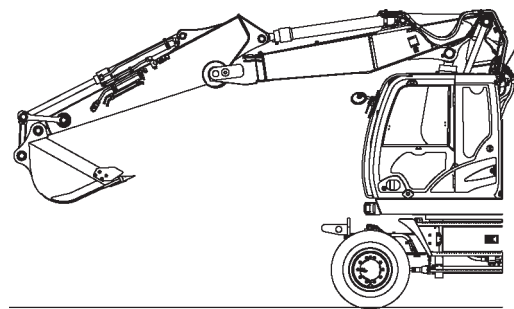

TLAA-04-04-002

SECTION 4 OPERATIONAL PERFORMANCE TEST

Group 4 Machine Performance Test

Measurement:

1. Select the following conditions.

Engine Control Dial	Power Mode	Auto-Idle Switch	Work Mode	Brake Switch
Fast Idle	PWR	OFF	Digging Mode	Work Brake

2. Raise the boom and swing the upperstructure in full stroke at the same time. Measure the time required to swing the upperstructure 90 degrees and height (H) of the bucket teeth. (The bucket should be empty.)
3. Repeat the measurement three times and calculate the mean values.

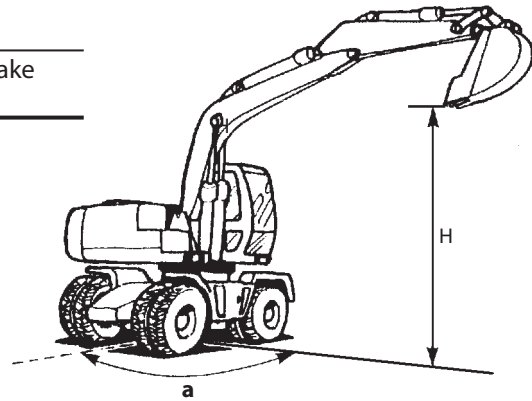

T212-07-03-007

Evaluation:

Refer to Operational Performance Standard.

a- 90 Degrees

Remedy:

Refer to Troubleshooting B.

SECTION 4 OPERATIONAL PERFORMANCE TEST

Group 5 Component Test

Pump 1/Pump 2 Flow Rate Control Solenoid Valve Set Pressure

Use MPDr. and a pressure gauge at the same time.

Preparation:

1. Stop the engine.
2. Push the air bleed valve on top of the hydraulic oil tank and bleed air.
3. Disconnect hose (7) from the solenoid valve to be measured. Install tee (4), hose (5), adapter (3), adapter (6), and pressure gauge (2) between disconnected hose (7) and solenoid valve unit (1).

 : 19 mm, 22 mm

Connect MPDr. and select the monitoring function.

4. Start the engine. Confirm that no oil leakage is observed at the pressure gauge (2) connection.
5. Maintain the hydraulic oil temperature at 50 ± 5 °C.

Measurement:

1. Select the following conditions.

Engine Control Dial	Power Mode	Auto-Idle Switch	Work Mode
Fast Idle	PWR	OFF	Digging Mode
Slow Idle	PWR	OFF	Digging Mode

2. Perform the following procedures for the solenoid valve to be measured.
 - Pump 1 Flow Rate Control Solenoid Valve (9): Turn Manual Regeneration Request ON by using MPDr..
 - Pump 2 Flow Rate Control Solenoid Valve (8): Descend the slope without depressing the accelerator pedal.
3. Read the values on both MPDr. and pressure gauge (2).
4. Repeat the measurement three times and calculate the mean values.

Evaluation:

Refer to Operational Performance Standard.

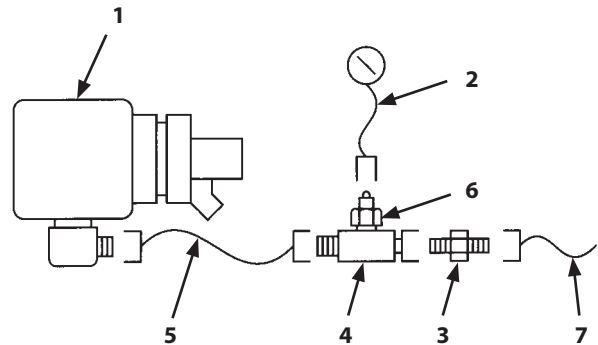

T157-05-04-002

- | | |
|-----------------------------|----------------------|
| 1- Solenoid Valve Unit | 5- Hose (4334307) |
| 2- Pressure Gauge (ST 6942) | 6- Adapter (ST 6069) |
| 3- Adapter (ST 6460) | 7- Hose |
| 4- Tee (ST 6450) | |

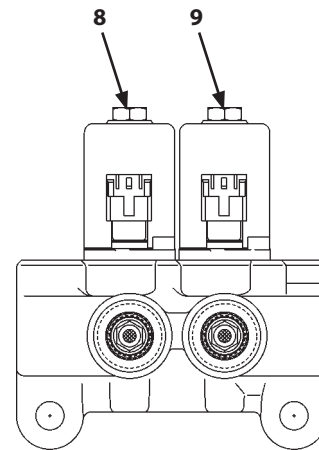

TLAA-01-02-001

- | | |
|--|--|
| 8- Pump 2 Flow Rate Control Solenoid Valve | 9- Pump 1 Flow Rate Control Solenoid Valve |
|--|--|

SECTION 4 OPERATIONAL PERFORMANCE TEST

Group 5 Component Test

Overload Relief Valve Set Pressure

Summary:

1. The circuit pressure must be increased by applying an external force while blocking the return circuit of the control valve. However, this measuring method is hazardous and the results obtained with this method are unreliable.
2. Accordingly, the overload relief valve assembly should be removed from the machine and checked on a specified test stand at a correct oil flow rate.
3. Measure the pressure on the machine is not recommended because of above mentioned reasons. If the measurement on the machine is required, please substitute the measurement of the main relief set pressure. The main relief set pressure can be also measured by using MPDr..

Preparation:

1. Stop the engine.
2. Push the air bleed valve on top of the hydraulic oil tank and bleed air.
3. Remove the plug from the delivery pressure check port of the main pump to be measured. Install adapter (ST 6069), hose (ST 6943), and pressure gauge (ST 6941) to the delivery pressure check port of the main pump to be measured.

 : 19 mm

 : 6 mm

4. Connect MPDr. and select the monitoring function. Start the engine. Confirm that no oil leakage is observed at the pressure gauge connection.
5. Maintain the hydraulic oil temperature at 50±5 °C.

Measurement:

1. Select the following conditions.

Engine Control Dial	Power Mode	Auto-Idle Switch	Work Mode
Fast Idle	PWR	OFF	Digging Mode

2. Slowly operate the bucket, arm, or boom control levers. Operate each cylinder to the stroke end (extend, retract) and relieve the main relief valve.
3. Read the pressure on the pressure gauge at this time.
4. Perform the measurement for the bucket, arm, and boom in sequence.
5. Repeat the measurement three times and calculate the mean values.

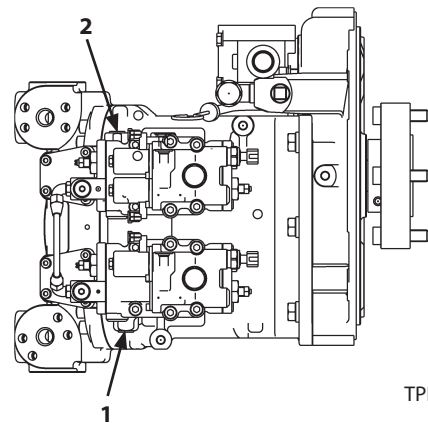

TPP3-03-01-002

- 1- Pump 1 Delivery Pressure Check Port
- 2- Pump 2 Delivery Pressure Check Port

SECTION 4 OPERATIONAL PERFORMANCE TEST

Group 5 Component Test

Swing Motor Drainage

Summary:

1. Measure the amount of oil draining from the swing motor while swinging the upperstructure and check the swing motor performance.
2. Secure absolute safety for the measuring persons as well as for the surrounding while measuring.
3. The amount of drain oil from the swing motor will change depending on the hydraulic oil temperature. Keep the hydraulic oil temperature.

Preparation:

1. Maintain hydraulic oil temperature at 50 ± 5 °C. Rotate the swing motor and warm the inside of the motor.
2. Stop the engine. Push air bleed valve (1) on top of the hydraulic oil tank and bleed air from the hydraulic oil tank.
3. Disconnect drain hose of the swing motor at the return pipe side. Install plug (ST 6214) to the return pipe.

 : 19 mm, 22 mm

Preconditions for Measurement:

1. Select the following conditions.

Engine Control Dial	Power Mode	Auto-Idle Switch	Work Mode
Fast Idle	PWR	OFF	Digging Mode

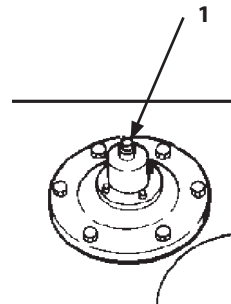

TDAA-04-05-008

1- Air Bleed Valve

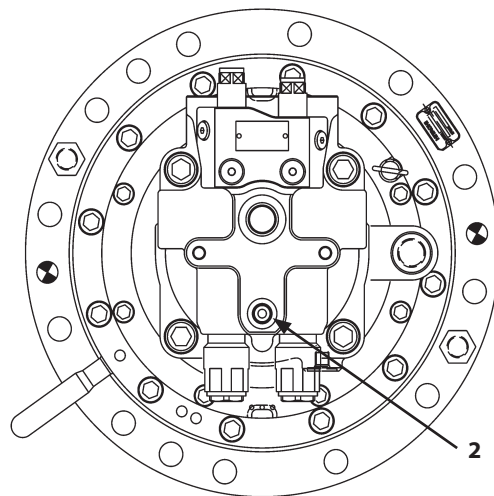

TPP3-03-02-002

2- Drain Hose Connecting Hole

SECTION 4 OPERATIONAL PERFORMANCE TEST

Group 5 Component Test

Brake Warning Pressure (Pressure- Decreasing)

⚠ CAUTION: If air is mixed in the brake system, the brake function is reduced and serious hazard may occur. Bleed air from the brake system after removing and installing the brake pipe lines and changing hydraulic oil. (Refer to TROUBLESHOOTING / Troubleshooting B.)

Summary:

Measure the pressure at the output port of the accumulator when the buzzer sounds while decreasing the accumulated brake pressure.

Preparation:

⚠ CAUTION: Install the measuring equipment under a machine. Install it on a flat and solid ground in order to prevent running away and an operating error. Raise the machine off the ground and support the machine by using blocks.

1. Stop the engine.
2. Push the air bleed valve on top of the hydraulic oil tank and bleed air.

Machine Jack-Up Method:

Raise the machine off the ground by using the blade and outrigger in case they are equipped for front and rear of the chassis.

Raise the front wheels off the ground by using the front attachment as illustrated in case the blade or outrigger is equipped for only rear of the chassis.



TLAB-04-05-100

SECTION 4 OPERATIONAL PERFORMANCE TEST

Group 6 Adjustment

How to Check Manual Regeneration Switch

When manual regeneration switch (1) or CAB harness has been repaired or replaced, check that manual regeneration switch (1) is operated normally.

Procedure

1. Start the engine.
2. Start MPDr.. Select the Aftertreatment Device Forced Manual Regeneration Control function.
3. The monitor will display Manual Regeneration Request screen (A) within 60 seconds and the Manual Regeneration Switch (1) indicator starts blinking.
4. The Manual Regeneration Switch (1) indicator is lit and the manual regeneration starts.
5. When the Manual Regeneration starts, stop the Aftertreatment Device Forced Manual Regeneration control by using MPDr..
6. Stop the engine and stop MPDr..

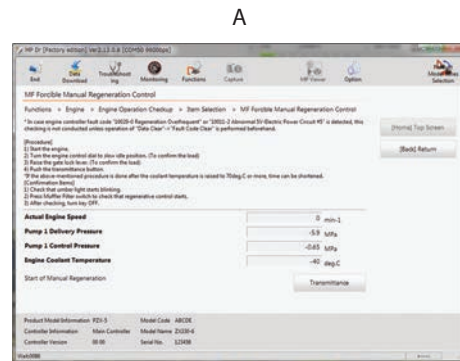

TDC1-04-06-008EN

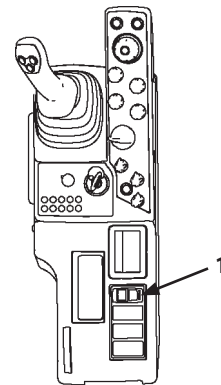

MDAA-01-330

SECTION 5

TROUBLESHOOTING

CONTENTS

Group 1 Diagnosing Procedure

Introduction.....	T5-1-1
Diagnosis Procedure.....	T5-1-2
Electrical System Inspection.....	T5-1-5
Precautions for Inspection and Maintenance.....	T5-1-6
Instructions for Disconnecting Connectors.....	T5-1-8
Fuse Inspection.....	T5-1-10
Fusible Link Inspection.....	T5-1-13
Battery Voltage Check.....	T5-1-14
Alternator Check.....	T5-1-15
Continuity Check.....	T5-1-16
Voltage and Current Measurement.....	T5-1-18
Check by False Signal.....	T5-1-26
Test Wire Harness.....	T5-1-27
Electric Lever Check.....	T5-1-29

Group 2 Monitor

Outline.....	T5-2-1
Operating Procedures of Service Menu.....	T5-2-2
Setting Menu.....	T5-2-50
Inspection of Engine Oil Level, Coolant Level, Hour Meter, and Fuel Gauge.....	T5-2-55
Fuel Gauge, Coolant Temperature Gauge, DEF Gauge.....	T5-2-56

Group 3 e-Service

Outline.....	T5-3-1
List of Operation Data.....	T5-3-2
Communication System.....	T5-3-4

Group 4 Component Layout

Main Component.....	T5-4-1
Electrical System (Overview).....	T5-4-5
Electrical System (Cab).....	T5-4-7
Electrical System (Switch Panel).....	T5-4-8
Electrical System (Controller, Relays).....	T5-4-10
Electrical System (Around Air Cleaner).....	T5-4-12
Electrical System (Relays).....	T5-4-13
Electrical System (Lights).....	T5-4-14
Engine.....	T5-4-15
Aftertreatment Device.....	T5-4-16
Pump Device.....	T5-4-17
Around Pump Device.....	T5-4-18
Control Valve.....	T5-4-19
Signal Control Valve.....	T5-4-20
Swing Shockless Valve.....	T5-4-21
Swing Device.....	T5-4-22

Travel Shockless Valve.....	T5-4-22
Accumulator Charging Valve.....	T5-4-22
Brake Valve.....	T5-4-22
Solenoid Valve Unit.....	T5-4-23
Transmission Control Solenoid Valve.....	T5-4-25
Travel Device.....	T5-4-25
Around DEF Tank.....	T5-4-26
Layout of Attachment Spec. Parts.....	T5-4-27
Auxiliary Control Solenoid Valve Unit.....	T5-4-28
Breaker Relief Solenoid Valve.....	T5-4-28
Selector Valve Control Valve.....	T5-4-28
Components in Control Valve.....	T5-4-30
Pilot Port.....	T5-4-48

Group 5 Troubleshooting A

Troubleshooting A (Base Machine Diagnosis By Using Fault Codes) Procedure.....	T5-5-1
MC1 Fault Code List.....	T5-5-3
MC2 Fault Code List.....	T5-5-22
ECM Fault Code List.....	T5-5-40
DCU Fault Code List.....	T5-5-54
Monitor Controller (Monitor) Fault Code List.....	T5-5-61
Monitor Controller (Information) Fault Code List.....	T5-5-62
Air Conditioner Controller Fault Code List.....	T5-5-65
Communication Terminal Fault Code List.....	T5-5-66
MC1 Fault Codes 11000 to 11002.....	T5-5-67
MC1 Fault Code 11003.....	T5-5-68
MC1 Fault Codes 11006, 11007, 11009.....	T5-5-70
Monitor Controller (Monitor) Fault Codes 13002, 13003, 13005.....	T5-5-70
CAN0 Harness Check.....	T5-5-71
ISO-CAN (Engine) Harness Check.....	T5-5-74
MC Fault Codes 11008, 11010, 11016.....	T5-5-77
Monitor Controller (Monitor) Fault Codes 13004, 13006, 13007.....	T5-5-77
CAN1 Harness Check.....	T5-5-78
MC1 Fault Code 11100.....	T5-5-83
MC1 Fault Code 11101.....	T5-5-84
MC1 Fault Codes 11200, 11202, 11205.....	T5-5-85
MC1 Fault Codes 11206, 11208.....	T5-5-86
MC1 Fault Codes 11301 to 11303.....	T5-5-87
MC1 Fault Codes 11305 to 11307.....	T5-5-88
MC1 Fault Codes 11310, 11311.....	T5-5-89
MC1 Fault Code 11325.....	T5-5-90
MC1 Fault Codes 11995, 11997.....	T5-5-91

SECTION 5 TROUBLESHOOTING

Group 1 Diagnosing Procedure

- Switch Lever and Remove Type

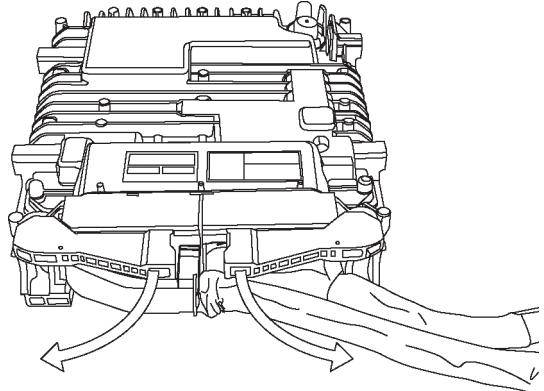

TDC1-05-01-004

- Pull Lock and and Remove Type

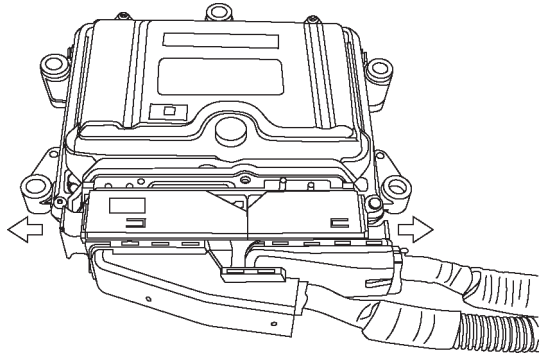

TDC1-05-01-003

- Lower Lock, Pull, and Remove Type

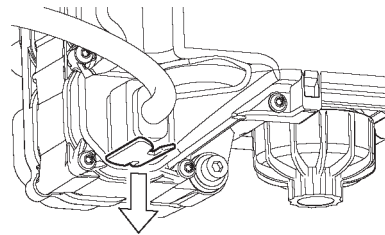

TDC1-05-01-005

SECTION 5 TROUBLESHOOTING

Group 1 Diagnosing Procedure

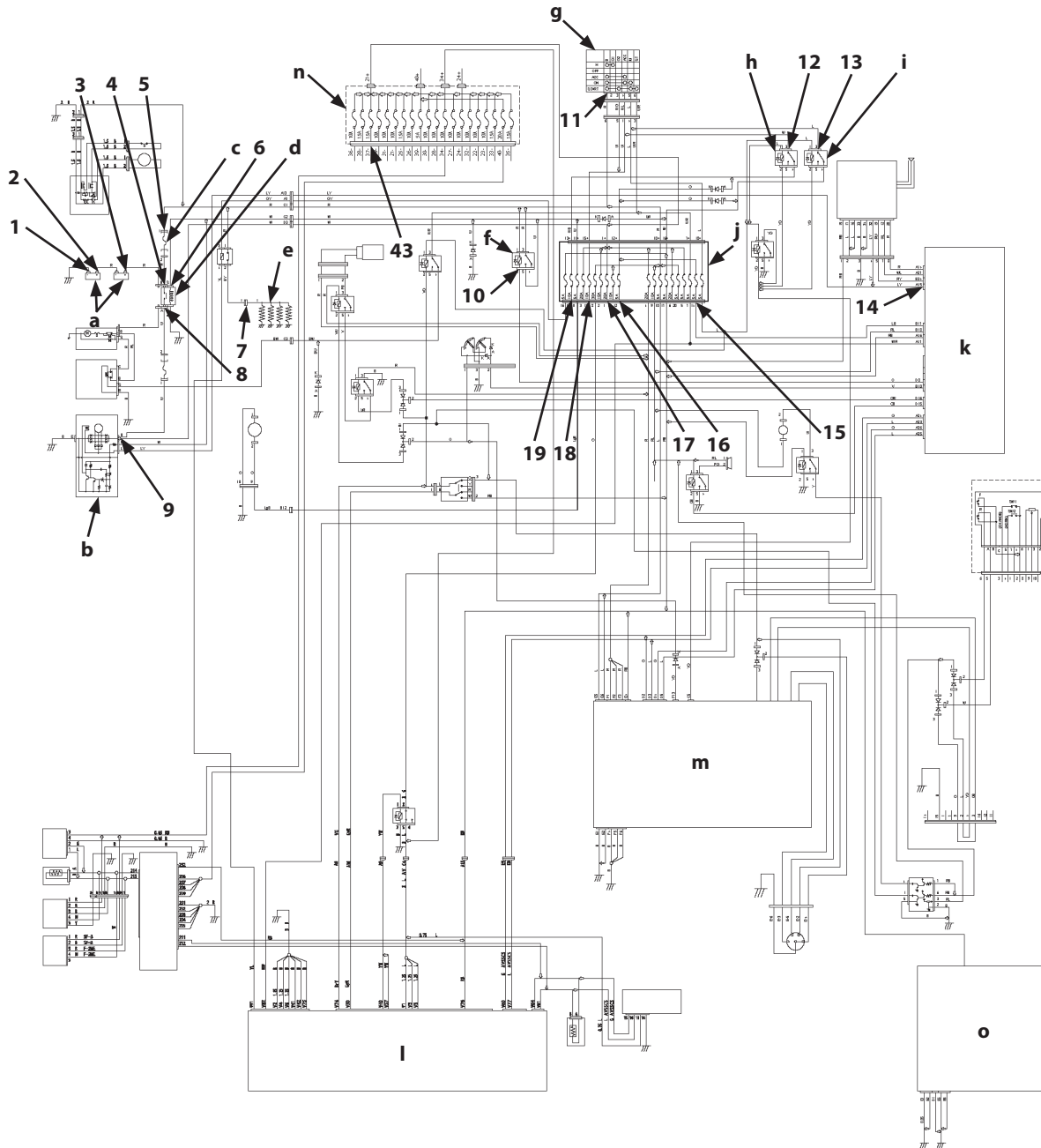

TLBE-05-01-001

- | | | | |
|------------------|--------------------|----------------------------|---------------|
| a- Battery | e- Glow Plug | i- Key Switch ON Cut Relay | m- MC1 |
| b- Alternator | f- Load Dump Relay | j- Fuse Box 1 | n- Fuse Box 2 |
| c- Fusible Link | g- Key Switch | k- Monitor Controller | o- MC2 |
| d- Battery Relay | h- ACC Cut Relay | l- ECM | |

SECTION 5 TROUBLESHOOTING

Group 1 Diagnosing Procedure

Electric Lever Check

Blade/Outrigger, Positioning, Auxiliary

Measure main output voltage and sub output voltage of the electric lever.

Measure output voltage when operating the control lever from neutral (b) to port 1 side (a) and to port 2 side (c).

- Main output voltage check: between connector terminal #3 and the body
- Sub output voltage check: between connector terminal #1 and the body

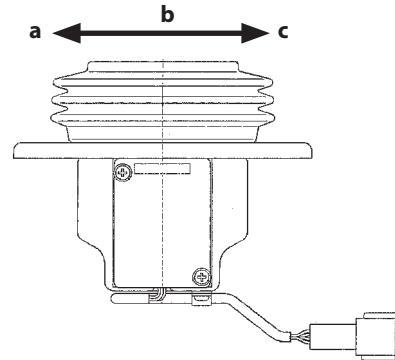

T1MG-03-09-018

Connector (Lever end)

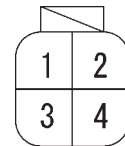

T24P-05-03-004

- a- Port 1 Side
- b- Neutral

- c- Port 2 Side

Assist 1, 2

Measure output voltage of assist switches 1 (d) and 2 (e).

Measure output voltage when operating assist switches 1 (d) and 2 (e) from neutral (b) to port 1 side (a) and to port 2 side (c).

- Output voltage check: between connector terminal #3 and the body

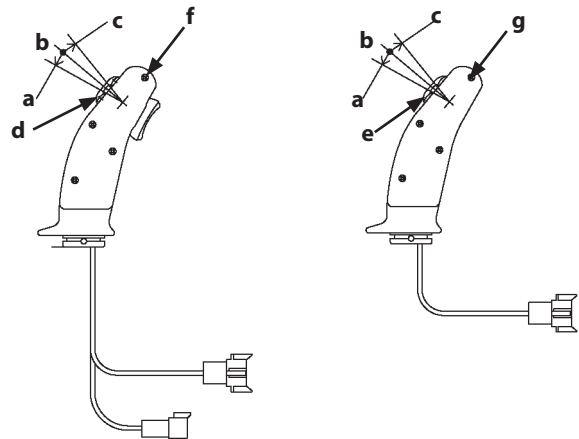

TLAA-05-01-002

Connector (Lever end)

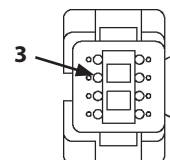

TLBE-05-01-009

- a- Port 1 Side
- b- Neutral
- c- Port 2 Side
- d- Assist Switch 1

- e- Assist Switch 2
- f- Left Control Lever
- g- Right Control Lever

SECTION 5 TROUBLESHOOTING

Group 2 Monitor

Item	Unit	Data
Inducement Level	0: Normal 1: Level 1 2: Level 2 4: Level 3	Current engine output restriction status
EXH FLUID Light	0: Lighting 1: Blinking	Alarm lighting/blinking status when urea SCR system is abnormal
EXH. SYSTEM Light	0: OFF 1: ON	Alarm ON/OFF status when urea SCR system is abnormal
Engine DERATE Light	0: OFF 1: ON	Alarm ON/OFF status at engine output restriction (Level 2)
Repeat Offence Flag	0: Normal 1: Monitoring	Status at monitoring of engine output restriction reappearance (REPEAT OFFENCE)
Directed Engine Speed	min ⁻¹	Input signal from engine control dial
Common Rail Pressure DP	MPa	Calculated value from control signal of common rail pressure and input signal from common rail pressure sensor
Regeneration Status 1	0: Normal 1: Regeneration 2: Required manual regeneration	Regeneration status of aftertreatment device
Coolant Temperature	°C	Input signal from coolant temperature sensor
Fuel Temperature	°C	Input signal from fuel temperature sensor
Engine Oil Pressure	kPa	Input signal from engine oil pressure sensor
Common Rail Pressure	MPa	Input signal from common rail pressure sensor
Atmospheric Pressure	kPa	Input signal from atmospheric pressure sensor
EGR Cooler1 Inlet Temp.	°C	Input signal from EGR cooler inlet temperature sensor
EGR Cooler1 Outlet Temp.	°C	Input signal from EGR cooler outlet temperature sensor
Intake Air Temperature	°C	Input signal from MAF sensor/intake-air temperature sensor
Boost Temperature	°C	Input signal from boost temperature sensor/boost pressure sensor
IAT in Manifold	°C	Input signal from intake manifold temperature sensor
DOC Outlet Exhaust Temp	°C	Input signal from DOC outlet exhaust temperature sensor
DOC Inlet Exhaust Temp	°C	Input signal from DOC inlet exhaust temperature sensor

SECTION 5 TROUBLESHOOTING

Group 2 Monitor

Item	Unit	Data
Warning Buzzer	OFF/ON	Overload alarm ON/OFF status
Assist Main Switch Indicator*	OFF/ON	Assist main switch ON/OFF status
Electric Lever Pilot Cut	OFF/ON	Pilot cut-off solenoid valve ON/OFF status
Bucket Lock Valve*	OFF/ON	Bucket roll-out pilot shut-off solenoid valve ON/OFF status
Outrigger/Blade ON/OFF Valve O/P 4	OFF/ON	Blade/outrigger solenoid valve (rear, left) ON/OFF status
Outrigger/Blade ON/OFF Valve O/P 3	OFF/ON	Blade/outrigger solenoid valve (rear, right) ON/OFF status
Outrigger/Blade ON/OFF Valve O/P 2	OFF/ON	Blade/outrigger solenoid valve (front, left) ON/OFF status
Outrigger/Blade ON/OFF Valve O/P 1	OFF/ON	Blade/outrigger solenoid valve (front, right) ON/OFF status
ON/OFF Valve Output 9	OFF/ON	-
ON/OFF Valve Output 8	OFF/ON	-
Boom Angle*	V	Input signal from boom angle sensor
Arm Angle*	V	Input signal from arm angle sensor

 NOTE: *: Option

SECTION 5 TROUBLESHOOTING

Group 2 Monitor

Communication Terminal Status

1. Turn select/set switch (3) and select Communication Terminal Status (4) on Service Menu. When pushing select/set switch (3), the Communication Terminal Status screen appears. (Figure A)
2. Each data of the communication terminals is displayed. (Refer To List of Communication Terminal Status.)
3. When pushing back switch (1), the previous screen appears.
4. When pushing the return to basic screen switch (2), the basic screen appears.

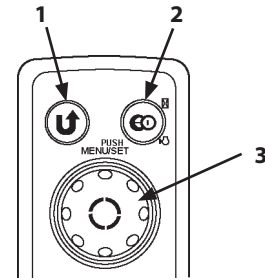

TDAA-05-02-030

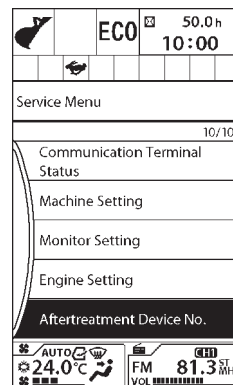

TDC1-05-02-011EN

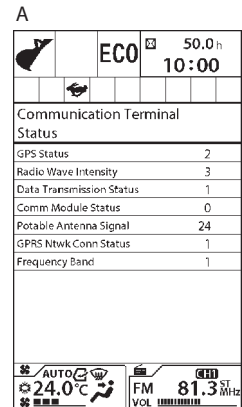

TDC1-05-02-034EN

SECTION 5 TROUBLESHOOTING

Group 2 Monitor

ATT5

Item	Unit	Minimum Adjustment	Adjustable Range	Initial Value
ATT 5 Type	0 to 10	-	0 to 10	6
ATT 5 No.	0 to 5	-	1 to 5	1
ATT 5 Pump 1 Maximum Flow Rate	L/min	0.5	69.5 to 139.5	139.5
ATT 5 Pump 2 Maximum Flow Rate	L/min	0.5	69.5 to 139.5	139.5
ATT 5 Engine Speed	min ⁻¹	10	-500 to 200	0
ATT 5 Relief Valve*	0 to 2	-	0 to 2	1
ATT 5 Selector Valve*	0, 1	-	0, 1	0
ATT 5 Auxiliary Flow Combiner Valve*	0, 1	-	0, 1	0
ATT 5 Breaker Relief Pressure	MPa	0.2	2 to 36	21
ATT 5 ATT Relief Pressure	MPa	0.2	10 to 36	27.4

ATT 6 to 11

Item	Unit	Minimum Adjustment	Adjustable Range	Initial Value
ATT 6 to 11 Type	0 to 10	-	0 to 10	0
ATT 6 to 11 No.	0 to 5	-	1 to 5	0
ATT 6 to 11 Pump 1 Maximum Flow Rate	L/min	0.5	69.5 to 139.5	139.5
ATT 6 to 11 Pump 2 Maximum Flow Rate	L/min	0.5	69.5 to 139.5	139.5
ATT 6 to 11 Engine Speed	min ⁻¹	10	-500 to 200	0
ATT 6 to 11 Relief Valve*	0 to 2	-	0 to 2	0
ATT 6 to 11 Selector Valve*	0, 1	-	0, 1	0
ATT 6 to 11 Auxiliary Flow Combiner Valve*	0, 1	-	0, 1	0
ATT 6 to 11 Breaker Relief Pressure	MPa	0.2	2 to 36	36
ATT 6 to 11 ATT Relief Pressure	MPa	0.2	10 to 36	27.4

 NOTE: *: Option

SECTION 5 TROUBLESHOOTING

Group 2 Monitor

Maintenance Mode

1. Turn select/set switch (3) and select Maintenance Mode (4) on Service Menu. When pushing select/set switch (3), the Maintenance Mode screen appears. (Figure A)
2. When pushing select/set switch (3), the color of selected item data is changed. Turn select/set switch (3), change the data, and push select/set switch (3).

 **NOTE:** Setting Value:

1: Maintenance Mode: ON

0: Maintenance Mode: OFF

3. Turn select/set switch (3) and select a check mark. When pushing select/set switch (3), the setting has been completed.
4. When Maintenance Mode is ON, maintenance mode alarm (5) is displayed on the basic screen.
5. When pushing back switch (1), the previous screen appears.
6. When pushing the return to basic screen switch (2), the basic screen appears.

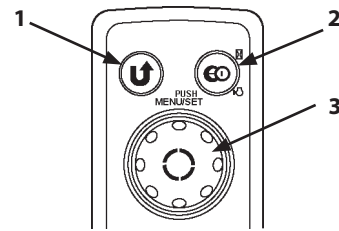

TDA-05-02-030

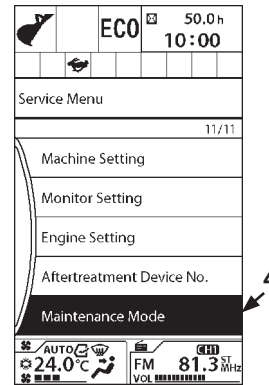

TDC1-05-02-204EN

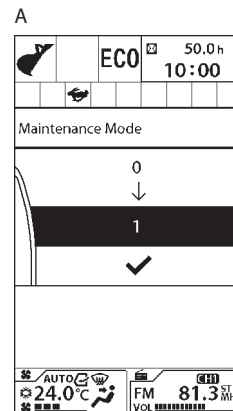

TDC1-05-02-205EN

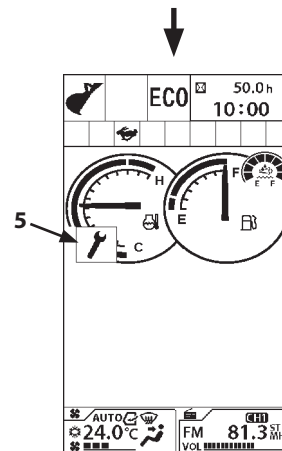

TDC1-05-02-203EN

SECTION 5 TROUBLESHOOTING

Group 3 e-Service

Item		Details
Attachment Operating Hours	Breaker Operating Hours	Total operating hours selecting breaker during a day. (Hours are recorded by attachment information from MC1.)
	Pulverizer Operating Hours	Total operating hours selecting pulverizer during a day. (Hours are recorded by attachment information from MC1.)
	Crusher Operating Hours	Total operating hours selecting crusher during a day. (Hours are recorded by attachment information from MC1.)
	Vibrating Hammer Operating Hours	Total operating hours selecting vibrating hammer during a day. (Hours are recorded by attachment information from MC1.)
	Bucket Operating Hours or Others	Total operating hours selecting bucket during a day. (Hours are recorded by attachment information from MC1.)
No Load Time		Total machine's waiting hours during a day. (Hours are recorded by each pressure sensor information from MC1.)
Engine Operating Hour Distribution Data		Engine operating hour distribution during a day. (Operating hours are recorded when the condition that the engine is operated continues over 5 minutes.)
Loaded Time Distribution Data		Machine operating hour distribution during a day. (Operating hours are recorded only when pilot pressure is continuously detected for more than 5 minutes while the engine runs.)
Latitude		Final position during a day. (Signal from GPS antenna.)
Longitude		Final position during a day. (Signal from GPS antenna.)

 **NOTE:** The daily operation in this table is equivalent to the hours between 0:00 and 23:59:59 counted by the monitor controller built-in clock. In case the engine is kept operated beyond 0:00, such data are recorded as those for the following day.

SECTION 5 TROUBLESHOOTING

Group 4 Component Layout

Column Display

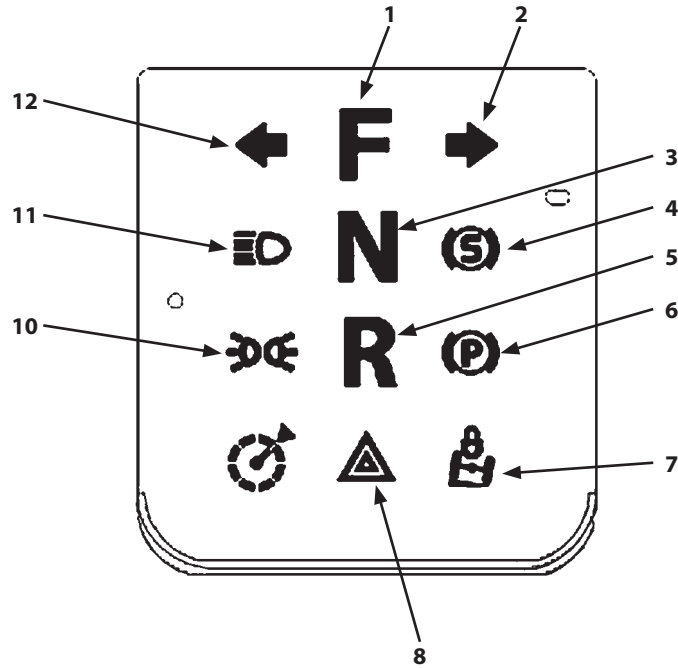

TLAA-01-02-007

- | | | |
|----------------------------------|-----------------------------|----------------------------------|
| 1- Travel Forward Indicator | 5- Travel Reverse Indicator | 10- Clearance Light Indicator |
| 2- Turn Signal Indicator (Right) | 6- Parking Brake Indicator | 11- High Beam Indicator |
| 3- Neutral Indicator | 7- Axle Lock Indicator | 12- Turn Signal Indicator (Left) |
| 4- Working Brake Indicator | 8- Hazard Light Indicator | |

SECTION 5 TROUBLESHOOTING

Group 4 Component Layout

Control Valve

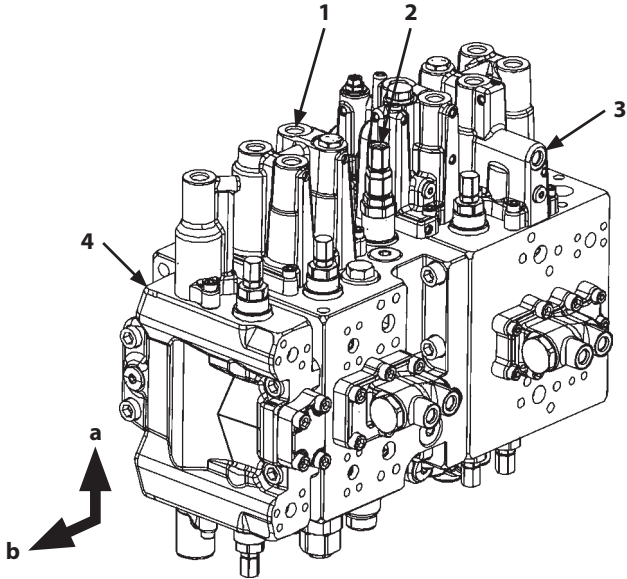

TLAA-03-03-004

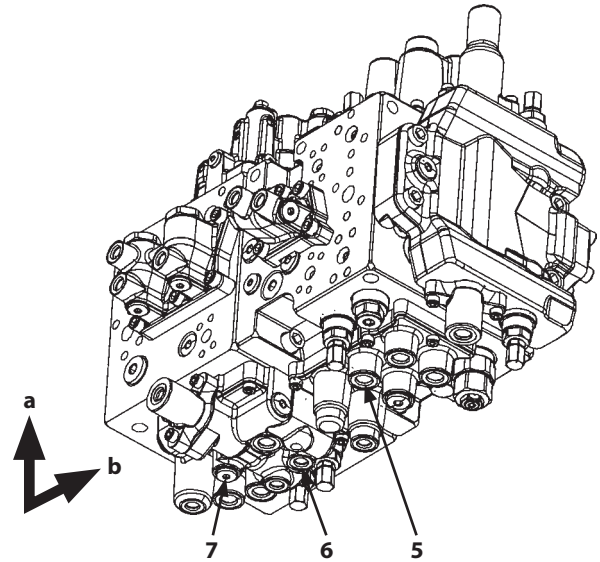

TLAA-03-03-003

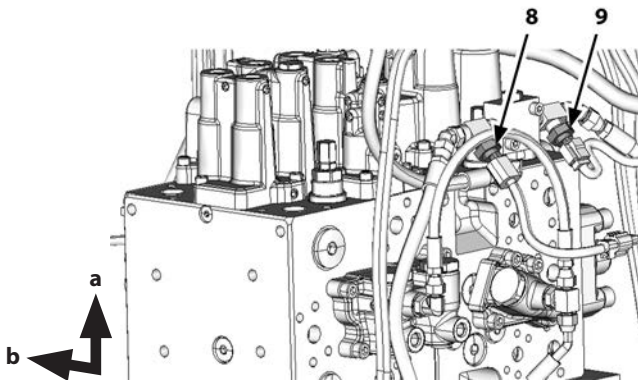

TLBE-01-02-010

a- Machine Upper Side

b- Machine Front Side

1- Pressure Sensor (Bucket Roll-In) Connecting Position

4- Positioning/Auxiliary 2 Block

7- Pressure Sensor (Arm Roll-Out) Connecting Position

9- Pressure Sensor (Blade/Outrigger) (2-Piece Boom)

2- Main Relief Valve

5- Pressure Sensor (Bucket Roll-Out) Connecting Position

8- Pressure Sensor (Positioning) (2-Piece Boom)

3- Pressure Sensor (Arm Roll-In) Connecting Position

6- Pressure Sensor (Boom Raise) Connecting Position

SECTION 5 TROUBLESHOOTING

Group 4 Component Layout

(Blank)

SECTION 5 TROUBLESHOOTING

Group 4 Component Layout

Section D-D

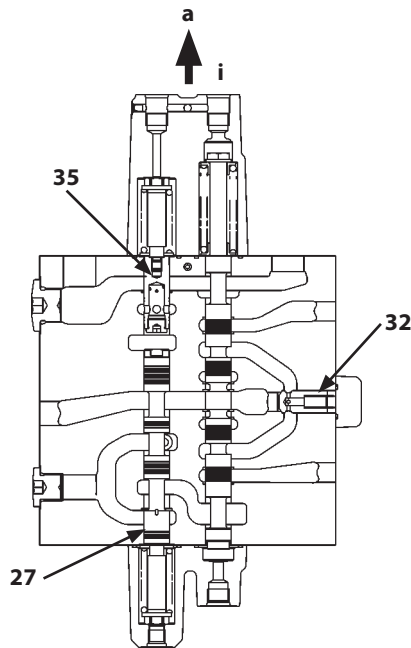

TLAA-03-03-011

Section E-E

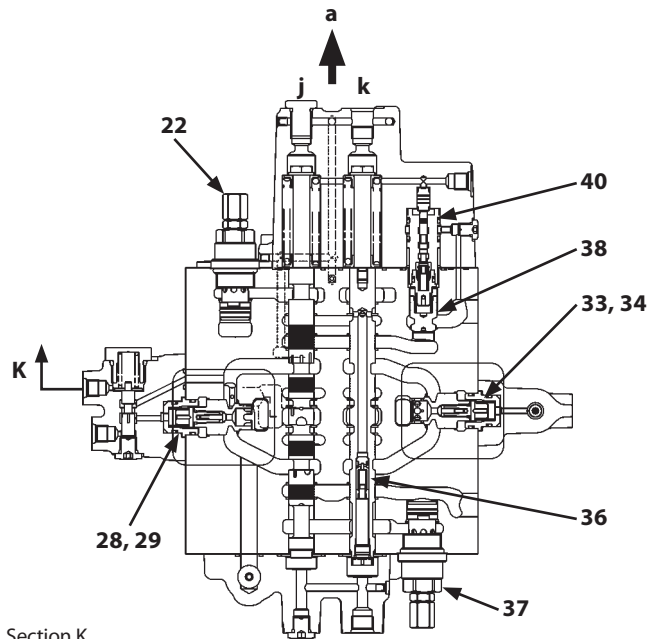

TLAA-03-03-012

Section K

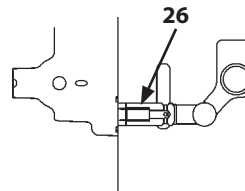

TLAA-03-03-100

a- Machine Top

i- Swing

j- Arm 2

k- Arm 1

- | | | | |
|--|--|--|---|
| 1- Check Valve (Main Relief Circuit) | 15- Bucket Regenerative Valve | 29- Arm 2 Flow Rate Control Valve (Poppet Valve) | 42- Auxiliary Flow Rate Control Valve (Poppet Valve) |
| 2- Main Relief Valve | 16- Overload Relief Valve (Bucket: Rod Side) | 30- Load Check Valve (Digging Regenerative Circuit) (Unused) | 43- Auxiliary Flow Rate Control Valve (Selector Valve) |
| 3- Check Valve (Main Relief Circuit) | 17- Overload Relief Valve (Bucket: Bottom Side) | 31- Digging Regenerative Valve (Unused) | 44- Overload Relief Valve (Auxiliary) |
| 4- Load Check Valve (Positioning/Auxiliary 2 Parallel Circuit) | 18- Boom Flow Rate Control Valve (Poppet Valve) | 32- Load Check Valve (Swing Tandem Circuit) | 45- Overload Relief Valve (Auxiliary) |
| 5- Load Check Valve (Bucket, Blade/Outrigger Parallel Circuit) | 19- Boom Lower Meter-In Cut Valve | 33- Arm 1 Flow Rate Control Valve (Poppet Valve) | 46- Load Check Valve (Blade/Outrigger Tandem Circuit) |
| 6- Check Valve (Auxiliary Flow Combiner Circuit) | 20- Boom Flow Rate Control Valve (Selector Valve) | 34- Arm 1 Flow Rate Control Valve (Selector Valve) | 47- Overload Relief Valve (Blade/Outrigger: Bottom Side) |
| 7- Auxiliary Flow Combiner Valve | 21- Boom Regenerative Valve | 35- Arm Regenerative Valve | 48- Overload Relief Valve (Blade/Outrigger: Rod Side) |
| 8- Load Check Valve (Blade/Outrigger Parallel Circuit) | 22- Overload Relief Valve (Boom: Bottom Side) | 36- Arm Regenerative Valve (Arm 1 Spool) | 49- Load Check Valve (Positioning/Auxiliary 2 Tandem Circuit) |
| 9- Load Check Valve (Orifice) (Bucket) | 23- Boom Anti-Drift Valve (Check Valve) | 37- Overload Relief Valve (Arm: Bottom Side) | 50- Overload Relief Valve (Positioning/Auxiliary 2) |
| 10- Make-Up Valve (Travel (Reverse) Side) | 24- Overload Relief Valve (Boom: Rod Side) | 38- Arm Rod Anti-Drift Valve (Check Valve) | 51- Overload Relief Valve (Positioning/Auxiliary 2) |
| 11- Make-Up Valve (Travel (Forward) Side) | 25- Boom Anti-Drift Valve (Selector Valve) | 39- Overload Relief Valve (Arm: Rod Side) | 52- Pump 1 |
| 12- Bucket Flow Rate Control Valve (Poppet Valve) | 26- Load Check Valve (Arm 2 Tandem Circuit) | 40- Arm Rod Anti-Drift Valve (Selector Valve) | 53- Pump 2 |
| 13- Bucket Flow Rate Control Valve (Selector Valve) | 27- Bypass Shut-Out Valve | 41- Load Check Valve (Boom 2 Parallel Circuit) | |
| 14- Bucket Regeneration Cut Valve | 28- Arm 2 Flow Rate Control Valve (Selector Valve) | | |

CLICK HERE TO **DOWNLOAD** THE COMPLETE MANUAL

- Thank you very much for reading the preview of the manual.
- You can download the complete manual from: www.heydownloads.com by clicking the link below



- Please note: If there is no response to CLICKING the link, please download this PDF first and then click on it.

CLICK HERE TO **DOWNLOAD** THE COMPLETE MANUAL

SECTION 5 TROUBLESHOOTING

Group 4 Component Layout

Pilot Valve Side

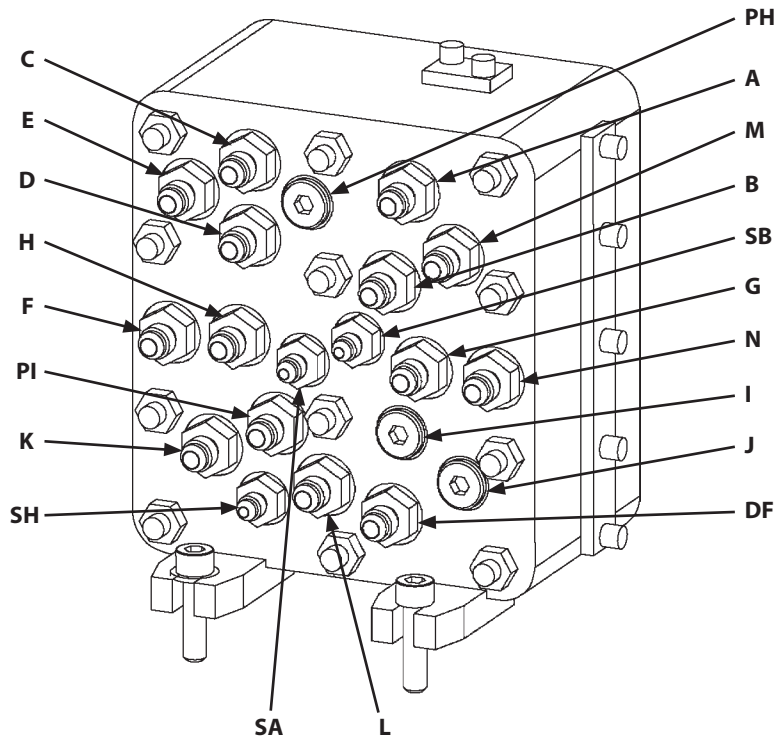

TLBE-03-09-001

Control Valve Side

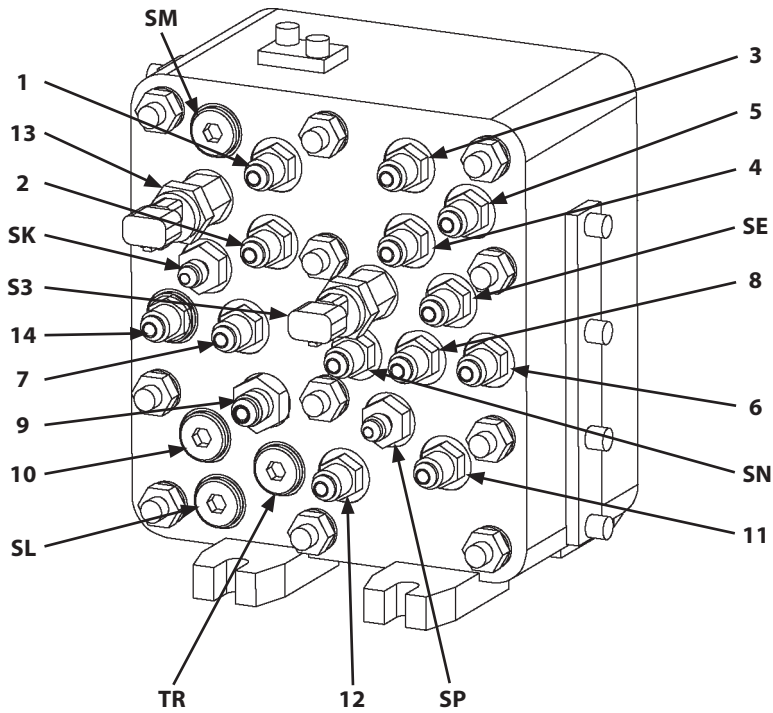

TLBE-03-09-002

SECTION 5 TROUBLESHOOTING

Group 5 Troubleshooting A

Fault Code	Trouble	Cause	Symptoms in Machine Operation When Trouble Occurs	Remedy
11206-3	Pump 1 Flow Control Pressure Sensor Circuit High Input	Voltage: more than 4.8 V	Even if the control lever is operated, the engine speed does not return to the fast idle speed at ECO mode. Machine is kept to travel at slow speed.	Check the wire harness. Replace the pump 1 control pressure sensor.
11206-4	Pump 1 Flow Control Pressure Sensor Circuit Low Input	Voltage: less than 0.1 V	Even if the control lever is operated, the engine speed does not return to the fast idle speed at ECO mode. Machine is kept to travel at slow speed.	Check the wire harness. Replace the pump 1 control pressure sensor.
11208-3	Pump 2 Flow Control Pressure Sensor Circuit High Input	Voltage: more than 4.8 V	Even if the control lever is operated, the engine speed does not return to the fast idle speed at ECO mode. Machine is kept to travel at slow speed.	Check the wire harness. Replace the pump 2 control pressure sensor.
11208-4	Pump 2 Flow Control Pressure Sensor Circuit Low Input	Voltage: less than 0.1 V	Even if the control lever is operated, the engine speed does not return to the fast idle speed at ECO mode. Machine is kept to travel at slow speed.	Check the wire harness. Replace the pump 2 control pressure sensor.

SECTION 5 TROUBLESHOOTING

Group 5 Troubleshooting A

Fault Code	Trouble	Cause	Symptoms in Machine Operation When Trouble Occurs	Remedy
11425-2	Implement Brake P/S Valve Abnormal FB	Solenoid valve output: 140 mA or more, feedback current: more than 920 mA and less than 70 mA; both are detected.	Work brake is not applied.	Check the wire harness.
11425-3	Implement Brake P/S Valve FB High Current	Current: more than 920 mA	Work brake is kept applied.	Check the wire harness.
11425-4	Implement Brake P/S Valve FB Low Current	Current: less than 70 mA	Work brake is not applied.	Check the wire harness.
11428-2	Arm 2 Flow Rate Control P/S Valve Abnormal FB	Solenoid valve output: 140 mA or more, feedback current: more than 920 mA and less than 70 mA; both are detected.	Combined operation of arm roll-in and bucket roll-in: Bucket roll-in operation speed is slow.	Check the wire harness.
11428-3	Arm 2 Flow Rate Control P/S Valve FB High Current	Current: more than 920 mA	Arm operation speed becomes slow.	Check the wire harness.
11428-4	Arm 2 Flow Rate Control P/S Valve FB Low Current	Current: less than 70 mA	Combined operation of arm roll-in and bucket roll-in: Bucket roll-in operation speed is slow.	Check the wire harness.

SECTION 5 TROUBLESHOOTING

Group 5 Troubleshooting A

Fault Code	Trouble	Cause	Symptoms in Machine Operation When Trouble Occurs	Remedy
15020-3	Auxiliary Monitoring Pressure Sensor Circuit High Input	Voltage: more than 4.6 V	Attachment operation is stopped.	Check the wire harness.
15020-4	Auxiliary Monitoring Pressure Sensor Circuit Low Input	Voltage: less than 0.1 V	Attachment operation is stopped.	Check the wire harness.
15021-3	Outrigger/Blade Monitoring Pressure Sensor Circuit High Input	Voltage: more than 4.6 V	Blade/outrigger operation is stopped.	Check the wire harness.
15021-4	Outrigger/Blade Monitoring Pressure Sensor Circuit Low Input	Voltage: less than 0.1 V	Blade/outrigger operation is stopped.	Check the wire harness.

SECTION 5 TROUBLESHOOTING

Group 5 Troubleshooting A

Fault Code	Trouble	Cause	Symptoms in Machine Operation When Trouble Occurs	Remedy
15530-2	Positioning 2 P/V Abnormal Current FB	Feedback current: more than 920 mA and less than 60 mA; both are detected.	Positioning operation is stopped.	Check the wire harness.
15530-3	Positioning 2 P/V Abnormal High Current FB	Current: more than 920 mA	Positioning operation is stopped.	Check the wire harness.
15530-4	Positioning 2 P/V Abnormal Low Current FB	Current: less than 56 mA	Positioning operation is stopped.	Check the wire harness.
15531-5	Outrigger/Blade ON/OFF Valve 1 (Front Left) Open Circuit	The circuit of blade/outrigger solenoid valve (front left) is abnormal.	Blade/outrigger (front left) operation is stopped.	Check the wire harness.
15532-5	Outrigger/Blade ON/OFF Valve 2 (Front Right) Open Circuit	The circuit of blade/outrigger solenoid valve (front right) is abnormal.	Blade/outrigger (front right) operation is stopped.	Check the wire harness.

SECTION 5 TROUBLESHOOTING

Group 5 Troubleshooting A

Fault Code		Trouble	Cause	Symptoms in Machine Operation When Trouble Occurs	Operating Rank					
SPN-FMI	DTC				A	B	C	D	E	F
1485-5	P0685	Abnormal Main Relay Circuit (Inactivation)	Voltage in the main relay system is 1 V or less with the main relay coil output ON.	The engine cannot start.				○		
1485-6	P0687	Abnormal Main Relay Circuit (Kept closed)	Even if receive the signal of the main relay coil output OFF, the main relay is kept ON.	Electrical power is kept supplying to the machine.	○					
10001-2	P0409	EGR Position Error	EGR position sensor signal are stock in a low or high stage.	Engine power decreases. Engine speed decreases.						○
10001-13	P1404	Abnormal EGR Zero-point Calibration	Zero point calibration value is not within the specification.	Engine power decreases. Engine speed decreases.						○
10002-2	P0404	Abnormal EGR Valve Control Circuit	Difference between the target valve lift and actual position is more than 20 %.	Engine power decreases. Engine speed decreases.						○

SECTION 5 TROUBLESHOOTING

Group 5 Troubleshooting A

Fault Code		Trouble	Cause	Symptoms in Machine Operation When Trouble Occurs	Operating Rank								
SPN-FMI	DTC				A	B	C	D	E	F			
10042-12	10529-12	-	Abnormal DEF/AdBlue Sensor Unit (Abnormal DEF/AdBlue Quality Sensor (Open or Short Circuit))	Short or open circuit, or internal malfunction of DEF quality sensor circuit.	Engine power decreases. Engine speed decreases.						○		
		P206D	Abnormal DEF/AdBlue Sensor Unit (Abnormal DEF/AdBlue Quality Sensor (Open Circuit))	Open circuit of DEF quality sensor circuit.	Engine power decreases. Engine speed decreases.							○	
		P206C	Abnormal DEF/AdBlue Sensor Unit (Abnormal DEF/AdBlue Quality Sensor (Short Circuit))	Short circuit of DEF quality sensor circuit.	Engine power decreases. Engine speed decreases.							○	
		P206A	DEF/AdBlue Quality Sensor Reset Error	Internal malfunction of DEF quality sensor.	Engine power decreases. Engine speed decreases.							○	
10530-12	P20E9	Abnormal DEF/AdBlue Pressure (High Pressure Error 1050 kPa)	Pressure: 1050 kPa or more.	Engine power decreases. Engine speed decreases.							○		
10532-12		-	Abnormal DEF/AdBlue Sensor Unit (Abnormal DEF/AdBlue Tank Temperature Sensor (Open or Short Circuit))	Signal voltage is abnormal.	Engine power decreases. Engine speed decreases.							○	
		P205D	Abnormal DEF/AdBlue Sensor Unit (Abnormal DEF/AdBlue Tank Temperature Sensor (Open Circuit))	Signal voltage is high.	Engine power decreases. Engine speed decreases.							○	
		P205C	Abnormal DEF/AdBlue Sensor Unit (Abnormal DEF/AdBlue Tank Temperature Sensor (Short Circuit))	Signal voltage is low.	Engine power decreases. Engine speed decreases.							○	
10533-12	P20E8	Abnormal DEF/AdBlue Pressure (Low Pressure in Normal Condition)	Pressure: 650 kPa or less.	Engine power decreases. Engine speed decreases.							○		
10536-12	P20A2	Abnormal Reverting Valve (Short Circuit at GND Side)	Short circuit between control circuit and GND.	Engine power decreases. Engine speed decreases.							○		

SECTION 5 TROUBLESHOOTING

Group 5 Troubleshooting A

MC1 Fault Codes 11000 to 11002

Fault Code	Trouble	Cause
11000-2	Abnormal EEPROM	Faulty MC1
11001-2	Abnormal RAM	Faulty MC1
11002-2	Abnormal A/D Converter	Faulty MC1

 **NOTE:** *When the engine and the machine is operated normally with the fault code displayed after retrial, the machine can be operated as it is.*

SECTION 5 TROUBLESHOOTING

Group 5 Troubleshooting A

**MC Fault Codes 11008, 11010, 11016
Monitor Controller (Monitor) Fault Codes
13004, 13006, 13007****Preparation**

- Check the wiring connections first.
- Check the CAN1 harness between the controllers.
(Refer to CAN1 Harness Check.)

Fault Code	Trouble	Inspection Method	Cause
11008-2	(MC) IC Communication Error 2	Continuity check (open circuit)	Open circuit in wire harness
		Discontinuity check	Short circuit in wire harness
11010-2	(MC) Monitor Controller Communication Error 2	Continuity check (open circuit)	Open circuit in wire harness
		Discontinuity check	Short circuit in wire harness
11016-2	(MC) Option Controller Communication Error 2	Continuity check (open circuit)	Open circuit in wire harness
		Discontinuity check	Short circuit in wire harness
13004-2	(Monitor Controller) Main Controller Communication Error 2	Continuity check (open circuit)	Open circuit in wire harness
		Discontinuity check	Short circuit in wire harness
13006-2	(Monitor Controller) ICF Communication Error 2	Continuity check (open circuit)	Open circuit in wire harness
		Discontinuity check	Short circuit in wire harness
13007-2	(Monitor Controller) Body Controller Communication Error	Continuity check (open circuit)	Open circuit in wire harness
		Discontinuity check	Short circuit in wire harness

SECTION 5 TROUBLESHOOTING

Group 5 Troubleshooting A

MC1 Fault Codes 11301 to 11303

Preparation

- Check the wiring connections first.
- Connect test harness (ST 6703) and dummy sensor equivalent to #4436535.
- Before inspection, set the key switch to the ON position.

Fault Code	Trouble	Procedure	Inspection Method	Evaluation	Cause
11301-3	Swing Pilot Pressure Sensor Circuit High Input	1	Measure voltage between B and the body.	Voltage: more than 4.8 V	YES: Short circuit in wire harness #1 and #2 NO: Go to Procedure No. 2.
		2	Measure voltage between A and C (GND).	0 V	YES: Open circuit in wire harness #3 NO: Faulty sensor
11301-4	Swing Pilot Pressure Sensor Circuit Low Input	1	Retry by using MPDr..	Un-displayed fault code	YES: Faulty sensor NO: Go to Procedure No. 2.
		2	Measure voltage between A and the body.	0 V	YES: Open circuit in wire harness #1 NO: Open circuit in wire harness #2
11302-3	Boom Raise Pilot Pressure Sensor Circuit High Input	1	Measure voltage between B and the body.	Voltage: more than 4.8 V	YES: Short circuit in wire harness #1 and #2 NO: Go to Procedure No. 2.
		2	Measure voltage between A and C (GND).	0 V	YES: Open circuit in wire harness #3 NO: Faulty sensor
11302-4	Boom Raise Pilot Pressure Sensor Circuit Low Input	1	Retry by using MPDr..	Un-displayed fault code	YES: Faulty sensor NO: Go to Procedure No. 2.
		2	Measure voltage between A and the body.	0 V	YES: Open circuit in wire harness #1 NO: Open circuit in wire harness #2
11303-3	Arm Roll-in Pilot Pressure Sensor Circuit High Input	1	Measure voltage between B and the body.	Voltage: more than 4.8 V	YES: Short circuit in wire harness #1 and #2 NO: Go to Procedure No. 2.
		2	Measure voltage between A and C (GND).	0 V	YES: Open circuit in wire harness #3 NO: Faulty sensor
11303-4	Arm Roll-in Pilot Pressure Sensor Circuit Low Input	1	Retry by using MPDr..	Un-displayed fault code	YES: Faulty sensor NO: Go to Procedure No. 2.
		2	Measure voltage between A and the body.	0 V	YES: Open circuit in wire harness #1 NO: Open circuit in wire harness #2

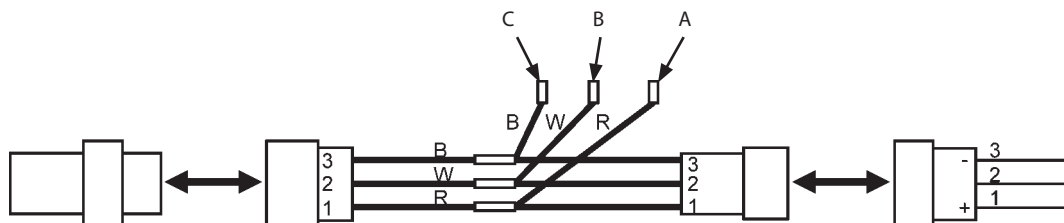

TDFB-05-01-002

SECTION 5 TROUBLESHOOTING

Group 5 Troubleshooting A

MC1 Fault Code 11409

Preparation

- Check the wiring connections first.

Fault Code	Trouble	Procedure	Inspection Method	Evaluation	Cause
11409-2	Aftertreatment Device Regenerative (Pump 1 Flow Rate Increase) Solenoid Valve Abnormal Feedback	1	Measure resistance between solenoid valve #1 and #2.	0/∞ Ω (Specification: 22 Ω)	YES: Faulty solenoid valve NO: Go to Procedure No. 2.
		2	Measure voltage between solenoid valve harness end #1 and the body.	0 V	YES: Open circuit in wire harness #1 NO: Go to Procedure No. 3.
		3	Monitor Aftertreatment Device Regeneration P/S Valve Output (SZ) FB.	0 mA	YES: Open circuit in wire harness #2 NO: Short circuit in wire harness #1 and #2
11409-3	Aftertreatment Device Regenerative (Pump 1 Flow Rate Increase) Solenoid Valve Feedback High Current	1	Measure resistance between solenoid valve #1 and #2.	0 Ω (Specification: 22 Ω)	YES: Faulty solenoid valve NO: Short circuit in wire harness #1 and #2
11409-4	Aftertreatment Device Regenerative (Pump 1 Flow Rate Increase) Solenoid Valve Feedback Low Current	1	Measure resistance between solenoid valve #1 and #2.	∞ Ω (Specification: 22 Ω)	YES: Faulty solenoid valve NO: Go to Procedure No. 2.
		2	Measure voltage between solenoid valve harness end #1 and the body.	0 V	YES: Open circuit in wire harness #1 NO: Open circuit in wire harness #2

Connector (Wire harness end)

- Solenoid Valve Connector



TDC1-05-05-026

SECTION 5 TROUBLESHOOTING

Group 5 Troubleshooting A

MC1 Fault Codes 11460, 11461

Preparation

- Check the wiring connections first.

Fault Code	Trouble	Procedure	Inspection Method	Evaluation	Cause
11460-2	T/M Switch Hi Line Open Circuit	1	Measure voltage between solenoid valve harness end #2 and the body.	0 V	YES: Open circuit in wire harness #2
					NO: Open circuit in wire harness #1
11461-2	T/M Switch Lo Line Open Circuit	1	Measure voltage between solenoid valve harness end #2 and the body.	0 V	YES: Open circuit in wire harness #2
					NO: Open circuit in wire harness #1

Connector (Wire harness end)

- Solenoid Valve Connector



T81R-05-03-006

SECTION 5 TROUBLESHOOTING

Group 5 Troubleshooting A

MC2 Fault Codes 15014, 15015

Preparation

- Check the wiring connections first.
- Before inspection, set the key switch to the ON position.

Fault Code	Trouble	Procedure	Inspection Method	Evaluation	Cause
15014-3	Lever Stroke Signal 1 (Main) Sensor Circuit High Input	1	Measure voltage between terminal #4 and the body.	Voltage: more than 4.55 V	YES: Short circuit in wire harness #1 and #4
					NO: Faulty blade/outrigger lever
15014-4	Lever Stroke Signal 1 (Main) Sensor Circuit Low Input	1	Retry by using MPDr..	Un-displayed fault code	YES: Faulty blade/outrigger lever NO: Go to Procedure No. 2.
		2	Measure voltage between terminal #1 and the body.	0 V	YES: Open circuit in wire harness #1 NO: Go to Procedure No. 3.
		3	Measure voltage between #1 and #3 (GND).	0 V	YES: Open circuit in wire harness #3 NO: Open circuit in wire harness #4
15015-3	Lever Stroke Signal 2 (Sub) Sensor Circuit High Input	1	Measure voltage between terminal #2 and the body.	Voltage: more than 4.85 V	YES: Short circuit in wire harness #1 and #2
					NO: Faulty blade/outrigger lever
15015-4	Lever Stroke Signal 2 (Sub) Sensor Circuit Low Input	1	Retry by using MPDr..	Un-displayed fault code	YES: Faulty blade/outrigger lever NO: Go to Procedure No. 2.
		2	Measure voltage between terminal #1 and the body.	0 V	YES: Open circuit in wire harness #1 NO: Go to Procedure No. 3.
		3	Measure voltage between #1 and #3 (GND).	0 V	YES: Open circuit in wire harness #3 NO: Open circuit in wire harness #2

Connector (Wire harness end)

- Blade/Outrigger Lever



T24P-05-03-004

SECTION 5 TROUBLESHOOTING

Group 5 Troubleshooting A

MC2 Fault Code 15032

Preparation

- Check the wiring connections first.

Fault Code	Trouble	Procedure	Inspection Method	Evaluation	Cause
15032-3	Pedal Signal Sum Fatal High Input	1	Monitor Pedal Signal 1 (Main).	over 2.5 V	YES: Short circuit in wire harness #1 and #4 NO: Go to Procedure No. 2.
		2	Monitor Pedal Signal 2 (Sub).	over 2.5 V	YES: Short circuit in wire harness #1 and #2 NO: Faulty positioning pedal (electric lever)
15032-4	Pedal Signal Sum Fatal Low Input	1	Monitor Pedal Signal 1 (Main).	less than 2.5 V	YES: Open circuit in wire harness #4 NO: Go to Procedure No. 2.
		2	Monitor Pedal Signal 2 (Sub).	less than 2.5 V	YES: Open circuit in wire harness #2 NO: Faulty positioning pedal (electric lever)

Connector (Wire harness end)

- Positioning Pedal

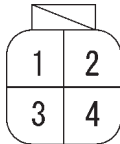

T24P-05-03-004

SECTION 5 TROUBLESHOOTING

Group 5 Troubleshooting A

MC2 Fault Code 15527

Preparation

- Check the wiring connections first.

Fault Code	Trouble	Procedure	Inspection Method	Evaluation	Cause
15527-2	Assist 3 P/V Abnormal Current FB	1	Measure resistance between solenoid valve #1 and #2.	0/∞ Ω (Specification: 22 Ω)	YES: Faulty solenoid valve NO: Go to Procedure No. 2.
		2	Measure voltage between solenoid valve harness end #1 and the body.	0 V	YES: Open circuit in wire harness #1 NO: Go to Procedure No. 3.
		3	Monitor Assist 3 P/S Output FB.	0 mA	YES: Open circuit in wire harness #2 NO: Short circuit in wire harness #1 and #2
15527-3	Assist 3 P/V Abnormal High Current FB	1	Measure resistance between solenoid valve #1 and #2.	0 Ω (Specification: 22 Ω)	YES: Faulty solenoid valve NO: Short circuit in wire harness #1 and #2
15527-4	Assist 3 P/V Abnormal Low Current FB	1	Measure resistance between solenoid valve #1 and #2.	∞ Ω (Specification: 22 Ω)	YES: Faulty solenoid valve NO: Go to Procedure No. 2.
		2	Measure voltage between solenoid valve harness end #1 and the body.	0 V	YES: Open circuit in wire harness #1 NO: Open circuit in wire harness #2

Connector (Wire harness end)

- Solenoid Valve Connector



TDC1-05-05-026

SECTION 5 TROUBLESHOOTING

Group 5 Troubleshooting A

Monitor Controller (Information) Fault Code 13311

Fault Code	Trouble	Procedure	Inspection Method	Evaluation	Cause
13311-3	Fuel Level Sensor Circuit High Input	1	Measure resistance between sensor #1 and #2.	The value is not within the specification of below table.	YES: Faulty sensor. NO: Go to Procedure No. 2.
		2	Measure voltage between sensor harness end #1 and the body.	0 V	YES: Open circuit in wire harness #1. NO: Open circuit in wire harness #2.
13311-4	Fuel Level Sensor Circuit Low Input	1	Measure resistance between sensor #1 and #2.	The value is not within the specification of below table.	YES: Faulty sensor. NO: Short circuit in wire harness #1 and #2.

 **NOTE:**

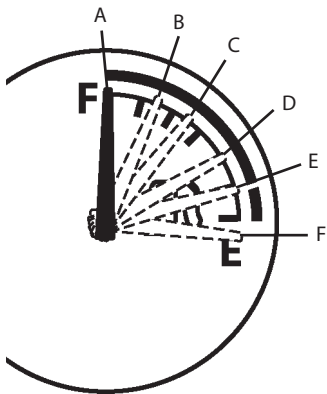
Fuel Gauge	No.	Fuel Level (%)	Fuel Sensor (Ω)
	A	100 (FULL)	$10^{0.4}$
	B	75	26
	C	50	38 ± 5
	D	25	53
	E	6	-
	F	0 (EMPTY)	90^{+10}_0

TLAA-05-02-082

Connector (Wire harness end)

- Fuel Sensor



TDCD-05-06-010

SECTION 5 TROUBLESHOOTING

Group 6 Troubleshooting B

Parts	Power Digging Switch	Pilot Shut-Off Switch (Pilot Shut-Off Lever)	Manual Regeneration Switch
Item			
Function	This switch shifts 4-spool solenoid valve unit (SG) and activates power digging. ON: 0 V→Pressure increases. OFF: 5 V→Pressure does not increase.	This switch shifts pilot shut-off solenoid valve.	This switch performs manual regeneration of the aftertreatment device.
Symptoms in control system when trouble occurs	Open circuit: Pressure does not increase. Short circuit: Pressure increase only for 8 seconds after the key switch is turned ON.	Open circuit: Pilot shut-off switch is always OFF. Pilot shut-off solenoid valve is not shifted. Even if lever is operated with pilot shut-off lever in UNLOCK position, all actuators are not operated. Short circuit: Pilot shut-off switch is always ON. Engine does not start. If shorted circuit occurs while engine running and even if lever is operated with pilot shut-off lever in LOCK position, actuator is operated.	Open circuit: Manual regeneration switch is always OFF. Even if manual regeneration switch is turned ON, aftertreatment device is not regenerated. Short circuit: Manual regeneration switch is always ON.
Symptoms in machine operation when trouble occurs.	Same as shown above	Same as shown above	Same as shown above
Evaluation by Fault Code	-	-	-
Evaluation by Monitoring	MC1: Power Boost Switch	MC1: Pilot Control Shut-Off Lever Switch	ECM: Manual Regeneration Switch
Evaluation by using Test Harness	-	-	-
Note	-	-	-
Descriptions of Control (Operational Principle Section in T/M)	T2-2	T2-5	T2-2

SECTION 5 TROUBLESHOOTING

Group 6 Troubleshooting B

Parts	Auto Axle Lock Switch	Work Brake Release Switch	Travel N Sensor
Item			
Function	This switch shifts auto axle lock.	This switch releases work brake and makes the machine travel.	This sensor displays speedometer according to the travel N sensor output. This sensor detects travel motor rotation speed for creeper mode travel speed control, travel motor excessive rotation control, and forward/reverse shifting restriction control.
Symptoms in control system when trouble occurs	No signals arrive to MC1.	No signals arrive to MC1.	Speedometer does not work. Travel motor excessive rotation control and forward/reverse shifting restriction control are not activated.
Symptoms in machine operation when trouble occurs	Axle is kept locked.	Work brake can not be released even if depressing the brake pedal.	Speedometer does not work. Engine speed does not decrease when traveling on a down slope.
Evaluation by Fault Code	-	-	-
Evaluation by Monitoring	MC1: Auto Axle Lock Switch	MC1: Working Brake Release Switch	MC1: Speed, Speed Pulse
Evaluation by using Test Harness	-	-	-
Note	-	-	-
Descriptions of Control (Operational Principle Section in T/M)	T2-2	T2-2	T2-2

SECTION 5 TROUBLESHOOTING

Group 6 Troubleshooting B

Parts Item	Travel Motor Displacement Angle Control Solenoid Valve	Transmission Control Solenoid Valve
Function	This valve shifts travel motor displacement angle.	This valve controls parking brake and travel mode in transmission.
Symptoms in control system when trouble occurs	High current: Travel motor displacement angle is fixed in the minimum inclination. Low current: Travel motor displacement angle is fixed in the maximum inclination.	When travel mode selector solenoid valve is stuck in neutral position, parking brake is kept applied despite of operating FNR switch. When travel mode selector solenoid valve is stuck in Fast or Slow position, Fast/Slow of transmission are not shifted despite of operating travel mode switch.
Symptoms in machine operation when trouble occurs	Same as shown above	Same as shown above
Evaluation by Fault Code	11422	11460, 11461
Evaluation by Monitoring	MC1: Travel Motor Displ Ctrl P/S O/P, Travel Motor P/S Output FB	-
Evaluation by using Test Harness	-	-
Note	-	-
Descriptions of Control (Operational Principle Section in T/M)	T2-2, T3-8	T2-2, T3-13

SECTION 5 TROUBLESHOOTING

Group 6 Troubleshooting B

Parts	Arm 1 Flow Rate Control Valve Control Spool	Bucket Flow Rate Control Valve Control Spool
Item		
Function	This spool is shifted by arm roll-in pilot pressure and supplies selection pressure to arm flow rate control valve 1 of 6-spool side of control valve.	This spool is shifted by arm roll-in pilot pressure and supplies boom raise pilot pressure to bucket flow rate control valve as selection pressure.
Symptoms in control system when trouble occurs	If spool is stuck in fully open position, arm speed becomes slow when performing arm single operation. (Arm flow rate control is activated constantly.) If spool is stuck in fully closed position, swing power is lack when performing combined operation of swing and arm roll-in. (Arm flow rate control is deactivated.)	If spool is stuck in fully open position, bucket speed becomes slow when performing combined operation of boom raise and bucket. (Bucket flow rate control is inoperable.) If spool is stuck in fully closed position, boom can not be raised when combined operation of bucket, arm roll-in and boom raise.
Symptoms in machine operation when trouble occurs.	Same as shown above	Same as shown above
Evaluation by Fault Code	-	-
Evaluation by Monitoring	-	-
Evaluation by using Test Harness	-	-
Note	-	-
Descriptions of Control (Operational Principle Section in T/M)	T3-9	T3-9

SECTION 5 TROUBLESHOOTING

Group 6 Troubleshooting B

All Actuator System Troubleshooting			
Trouble Symptom	A-1	A-2	A-3
All actuators do not work.	All actuators do not work.	All actuator operation speed are slow.	Travel operation speed is slow when performing travel single operation. Bucket single operation speed is slow. Boom is difficult to be raised when performing arm level crowding operation (All problems occur at the same time).
Parts			
MC1	○	●	
ECM		○	
Monitor Controller	○		
Torque Control Solenoid Valve		●	
Pilot Shut-Off Solenoid Valve	●		
Pump 2 Delivery Pressure Sensor			
Pressure Sensor (Swing)			
Pressure Sensor (Arm Roll-In)			
Pilot Shut-Off Switch	●		
Pilot Shut-Off Relay	●		
Security Relay	●		
Spool			
Main Relief Valve		○	
Arm 1 Flow Rate Control Valve			
Main Pump		●	●
Regulator		○	●
Pilot Pump		●	
Pilot Valve			
Pilot Relief Valve		●	
Pump 1 Flow Rate Control Valve (Signal Control Valve)			●
Pump 2 Flow Rate Control Valve (Signal Control Valve)			
Arm 1 Flow Rate Control Valve Control Spool (Signal Control Valve)			
Remark			

SECTION 5 TROUBLESHOOTING

Group 6 Troubleshooting B

Trouble Symptom	T-7
	Axle lock is not activated.
Parts	
MC1	○
Main Pump	
Regulator	
Brake Solenoid Valve	
Axle Lock Solenoid Valve	●
Travel Motor Displacement Angle Control Solenoid Valve	
Travel Mode Selector Solenoid Valve	
FNR Switch	
Travel Mode Switch	
Brake Switch	●
Engine Speed Control Mode Selection Switch	
Work Brake Release Switch	
Brake Pressure Sensor	
Brake Remain Pressure Sensor	
Travel N Sensor	
Control Valve	
Accumulator Charging Valve	
Brake Valve	
Transmission	
Front Axle	
Rear Axle	
Travel Motor	
Center Joint	
Pilot Valve	
Axle Lock Cylinder	○
Operate Check Valve (Axle Lock Cylinder)	●
Remark	

SECTION 5 TROUBLESHOOTING

Group 6 Troubleshooting B

E-4 ECO mode is faulty.

	Specification (min ⁻¹)	Remark
Fast Idle Speed (ECO mode)	1450±50	No load

Preparation

- In case other trouble symptoms occur, perform troubleshooting of these troubles first.
- The sensors detect the conditions necessary to operate ECO mode. Therefore, if these sensors fails, the power mode does not shift to ECO mode.
- Pump 1, 2 control pressure sensors, pump 1, 2 delivery pressure sensors are also related to the ECO mode control. However, if these sensors fail, other operating functions will be also affected.
- Refer to SYSTEM/Control System/ECO Mode Control.
- Check the wiring connections first.

Procedure	Inspection Method	Condition	Evaluation	Cause
1	Check continuity between MC1 harness end #F9 and the body.	Power Mode Switch: ON	$\infty \Omega$	YES: Open circuit in wire harness between power mode switch and MC1
				NO: Go to Procedure No. 2
2	Monitor Power Mode Switch and turn ON the power mode switch.	Key Switch: ON	OFF is displayed	YES: Faulty power mode switch
				NO: Faulty MC1

Connector (Wire harness end)

- MC1-F Connector

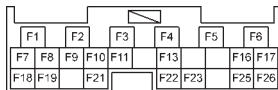

TLBE-05-06-001

SECTION 5 TROUBLESHOOTING

Group 6 Troubleshooting B

A-3 Travel operation speed is slow when performing travel single operation. Bucket single operation speed is slow. Boom is difficult to be raised when performing arm level crowding operation. (All problems occur at the same time.)

Preparation

- The pump 1 flow rate is minimized due to some reasons. Travel and bucket, which are driven by pressure oil from pump 1, move very slowly.
- Pressure oil from pump 2 is also routed to the arm and boom cylinders, and then the arm and boom can move at a slightly slow speed during single operation. However, during arm level crowding operation, pressure oil is routed to the arm prior to the boom, and then the boom hardly rise.
- Refer to SYSTEM/Hydraulic System.

Procedure	Inspection Method	Condition	Evaluation	Cause
1	Monitor Pump 1 Control Pressure.	Engine speed control mode selection switch: Pedal mode Operate the accelerator pedal.	Pressure increase according to accelerator pedal stroke.	YES: Faulty pump 1 regulator NO: Stuck pump 1 flow rate control valve in signal control valve or malfunction of maximum pump 1 flow rate limit control solenoid valve

SECTION 5 TROUBLESHOOTING

Group 6 Troubleshooting B

F-5 Bucket roll-in single operation speed is slightly slow. Bucket roll-in single operation does not move smoothly.

Preparation

- The bucket flow rate control valve or bucket regenerative valve may be faulty.
- Refer to COMPONENT OPERATION/Control Valve.

Procedure	Inspection Method	Condition	Evaluation	Cause
1	Measure pressure at port SK of signal control valve.	Combined relief operation of boom raise, arm roll-in, and bucket roll-in	The measured values are out of the specification. (Specification: approx. 3.9 MPa)	YES: Stuck of bucket flow rate control valve control spool in signal control valve NO: Go to Procedure No. 2
2	Disassemble and inspect the bucket flow rate control valve.	-	There is abnormality.	YES: Faulty bucket flow rate control valve NO: Go to Procedure No. 3
3	Disassemble and inspect the bucket regenerative valve.	-	There is abnormality.	YES: Faulty bucket regenerative valve NO: Find out cause of trouble by tracing other trouble symptoms.

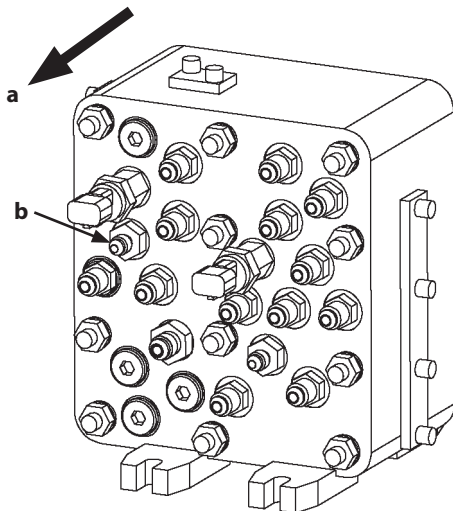

TLBE-03-09-004

a- Control Valve Side

b- Port SK

SECTION 5 TROUBLESHOOTING

Group 6 Troubleshooting B

Travel System Troubleshooting

T-1 Machine does not travel.

- When all following conditions exist, the machine can travel.
 FNR Switch : Forward or Reverse position
 Brake Switch : OFF position or Axle lock position
- Faulty transmission and/or axle (front and/or rear) may be the cause of this trouble. Check if a noise is emitted from each section.
- Check if parking brake indicator, work brake indicator, and neutral indicator on the monitor in the steering column monitor are OFF.
- Air mixing in the transmission hydraulic circuit may cause the parking brake to drag. Bleed air from the transmission by referring to T5-6-120.
- When other actuators (front attachment and swing) are operated normally, pumps 1, 2, pilot pump, pilot filter, and pilot relief valve are considered to be normal.
- Check the wiring connections first.

Procedure	Inspection Method	Condition	Evaluation	Cause
1	Monitor FNR Switch (F).	FNR switch: Forward position	OFF is displayed.	YES: Faulty FNR switch or open circuit in wire harness between FNR switch and MC1 NO: Go to Procedure No. 2
2	Monitor FNR Switch (R).	FNR switch: Reverse position	OFF is displayed.	YES: Faulty FNR switch or open circuit in wire harness between FNR switch and MC1 NO: Go to Procedure No. 3
3	Monitor Brake Switch (OFF).	Brake switch: OFF position	ON is displayed.	YES: Faulty brake switch or open circuit in wire harness between brake switch and MC1 NO: Go to Procedure No. 4
4	Monitor Forward Travel Pilot Cut.	FNR switch: Reverse position	OFF is displayed.	YES: Faulty travel forward Pi cut solenoid valve or open circuit in wire harness between the travel forward Pi cut solenoid valve and MC1 NO: Go to Procedure No. 5
5	Monitor Reverse Travel Pilot Cut.	FNR switch: Forward position	OFF is displayed.	YES: Faulty travel reverse Pi cut solenoid valve or open circuit in wire harness between the travel reverse Pi cut solenoid valve and MC1 NO: Go to Procedure No. 6

SECTION 5 TROUBLESHOOTING

Group 6 Troubleshooting B

B-3 Work brake is not applied.

- Check if the brake switch is in the work brake position or the auto axle lock switch is in the ON position before starting the troubleshooting.
- When the brake switch is in the work brake position or the auto axle lock switch is in the ON position, the work brake is applied. If the work brake is not applied with either switch set in the specified position, the circuit in harness between MC1 and brake switch may be open.
- When the speedometer is normal, the travel N sensor may be normal.
- When other actuators (front attachment, swing, and travel) are operated normally, the pilot pump is considered to be normal.
- Check the wiring connections first.

Procedure	Inspection Method	Condition	Evaluation	Cause
1	Monitor Brake Switch (S).	Brake switch: Work brake position	OFF is displayed.	YES: Faulty brake switch or open circuit in wire harness between brake switch and MC1 NO: Go to Procedure No. 2
2	Monitor Auto Axle Lock Switch.	Auto axle lock switch: ON	OFF is displayed.	YES: Faulty auto axle lock switch or open circuit in wire harness between the auto axle lock switch and MC1 NO: Go to Procedure No. 3
3	Monitor Brake Pressure.	Depress the brake pedal to the stroke end	Less than 6.4 MPa	YES: Faulty brake valve NO: Go to Procedure No. 4
4	Monitor Working Brake Release Switch.	Depress the brake pedal several times	Only ON is displayed.	YES: Faulty work brake release switch or open circuit in wire harness between the work brake release switch and MC1 NO: Go to Procedure No. 5
5	Monitor Working Brake P/S Output.	Brake switch: Work brake position or Auto axle lock switch: OFF position Work brake release switch: OFF	Less than 3.3 MPa	YES: Faulty brake solenoid valve or open circuit in wire harness between brake solenoid valve and MC1 NO: Faulty MC1

SECTION 5 TROUBLESHOOTING

Group 6 Troubleshooting B

Applicability of Exchange Inspection Method

Fault Code	Trouble	Remedy
11200-3	Pump 1 Delivery Pressure Sensor Circuit High Input	Exchange inspection method is applicable. (Wire Harness/Sensor)
11200-4	Pump 1 Delivery Pressure Sensor Circuit Low Input	
11202-3	Pump 2 Delivery Pressure Sensor Circuit High Input	
11202-4	Pump 2 Delivery Pressure Sensor Circuit Low Input	
11205-3	Pump 4 Delivery Pressure Sensor Circuit High Input	
11205-4	Pump 4 Delivery Pressure Sensor Circuit Low Input	
11310-3	Brake Pressure Sensor Circuit High Input	
11310-4	Brake Pressure Sensor Circuit Low Input	
11311-3	Brake Remaining Pressure Sensor Circuit High Input	
11311-4	Brake Remaining Pressure Sensor Circuit Low Input	
11206-3	Pump 1 Flow Control Pressure Sensor Circuit High Input	Exchange inspection method is applicable. (Wire Harness/Sensor)
11206-4	Pump 1 Flow Control Pressure Sensor Circuit Low Input	
11208-3	Pump 2 Flow Control Pressure Sensor Circuit High Input	
11208-4	Pump 2 Flow Control Pressure Sensor Circuit Low Input	
11301-3	Swing Pilot Pressure Sensor Circuit High Input	Exchange inspection method is applicable. (Wire Harness/Sensor)
11301-4	Swing Pilot Pressure Sensor Circuit Low Input	
11302-3	Boom Raise Pilot Pressure Sensor Circuit High Input	
11302-4	Boom Raise Pilot Pressure Sensor Circuit Low Input	
11303-3	Arm Roll-in Pilot Pressure Sensor Circuit High Input	
11303-4	Arm Roll-in Pilot Pressure Sensor Circuit Low Input	
11305-3	TravelForwardPilot Pressure Sensor Circuit High Input	
11305-4	TravelForwardPilot Pressure Sensor Circuit Low Input	
11306-3	TravelReversePilot Pressure Sensor Circuit High Input	
11306-4	TravelReversePilot Pressure Sensor Circuit Low Input	
11307-3	Front Pilot Pressure Sensor Circuit High Input	
11307-4	Front Pilot Pressure Sensor Circuit Low Input	
11325-3	Bucket Roll-In Pilot Pressure Sensor Circuit High Input	
11325-4	Bucket Roll-In Pilot Pressure Sensor Circuit Low Input	
11995-3	Arm Roll-Out Pilot Pressure Sensor Circuit High Input	
11995-4	Arm Roll-Out Pilot Pressure Sensor Circuit Low Input	
11997-3	Bucket Roll-Out Pilot Pressure Sensor Circuit High Input	
11997-4	Bucket Roll-Out Pilot Pressure Sensor Circuit Low Input	

SECTION 5 TROUBLESHOOTING

Group 6 Troubleshooting B

Recovery After Parking Brake Release

1. Loosen bleeder (2) to allow grease to be discharged.
2. Start the engine. Select travel mode between fast and slow around 8 or 9 times to release the grease.
3. Tighten bleeder (2).

⚠ WARNING: When engaging the parking brake, grease is discharged. If the discharged grease is kept left on the ground, the following cars may slip, possibly causing dangerous situation.

Take the most priority to notice the following cars and remove the discharged grease as soon as possible.

⚠ DANGER: When the parking brake is released, the machine becomes free to move, possibly creating hazardous conditions.

Before releasing the parking brake or connecting the brake system, be sure to lock tires with wheel stoppers.

⚠ CAUTION: The pressure inside the transmission is high.

Do not loosen bleeder (2) quickly or loosen it too much as bleeder (2) may fly out or high-pressure grease in the transmission may spout out. Loosen carefully and keep away from bleeder (2).

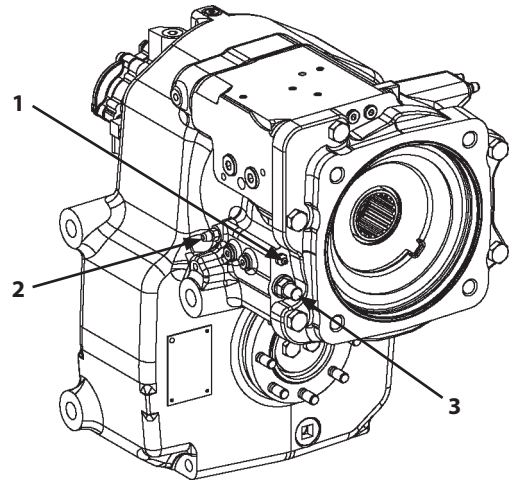

T21W-03-05-014

1- Nipple
2- Bleeder

3- Relief Valve

SECTION 5 TROUBLESHOOTING

Group 7 Air Conditioner

Troubleshooting

IMPORTANT:

- **When replacing the compressor due to the breakage of compressor from internal lock, sufficiently clean the air conditioner circuit or replace all the parts.**
- **When cleaning is insufficient or all the parts are not replaced, the air conditioner may be broken due to contaminants remaining in the circuit.**
- **Using deteriorated LLC (coolant) or low-concentration LLC, the heater core will receive a bad influence and it may lead water leaks and shorten the service life of machine. Replace coolant and manage LLC concentration according to the Operator's Manual.**



NOTE: The fault code of the air conditioner controller is displayed only on the monitor. It is not displayed on MPDr..

SECTION 5 TROUBLESHOOTING

Group 7 Air Conditioner

A: Frosted evaporator

Frosted evaporator	Stop air conditioner and melt ice.			
With voltage applied to magnet clutch	Faulty magnet clutch circuit	Check of clutch circuit	Replace the clutch relay	
	Faulty wiring of frost sensor	Short circuit check	Repair	
	Faulty frost sensor characteristics	Characteristic check	Replace the frost sensor	
	Frost sensor comes off from evaporator (faulty sensitivity)	Reinsert (floating distance from evaporator is 3 mm or less)		
No voltage applied to magnet clutch		Faulty magnet clutch	Replace the magnet clutch.	

B: Lack of refrigerant

Lack of refrigerant	Lack of refrigerant quantity	Charge refrigerant to proper level.	
	Gas leak	Check leak and charge with refrigerant after repairing faulty.	

C: Clogged in refrigeration cycle

Clogged in refrigeration cycle	Clogged receiver tank	Replace	
	Clogged foreign matter in piping	Replace	

D: Faulty expansion valve

Faulty expansion valve	Clogged valve (foreign matter)	Replace the valve.	
	Temporary clogged due to freezing valve (water intrusion)	Thoroughly perform purging after replacing valve and receiver.	

SECTION 5 TROUBLESHOOTING

Group 7 Air Conditioner

(Blank)

SECTION 5 TROUBLESHOOTING

Group 7 Air Conditioner

IMPORTANT:

- Always stop the engine when charging the air conditioner with refrigerant.
- Do not position the refrigerant container upside down during charging operation.
- When changing the refrigerant container during charging operation, be sure to perform the procedure in step 10.
- Charge the low-pressure side hose first.

6. Fully tighten charge hose (5) to manifold gauge (1). Open high pressure valve (2) and valve (9) of refrigerant container (8). Charge with refrigerant (R134a). Close high pressure valve (2) and valve (9) of refrigerant container (8) when high pressure gauge (11) reading reaches 98 kPa.

 **NOTE:** Use warm water of 40 °C or less to warm refrigerant container (8) to aid in charging operation.

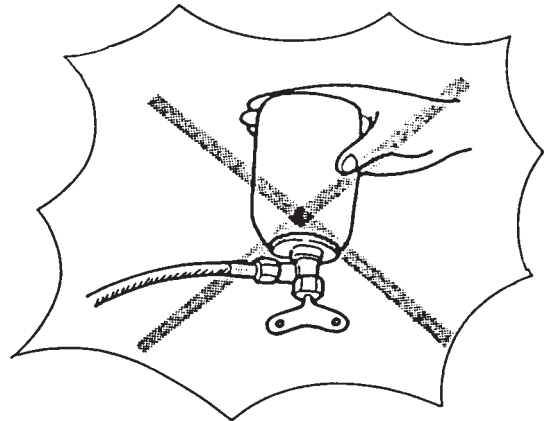

W115-02-10-008

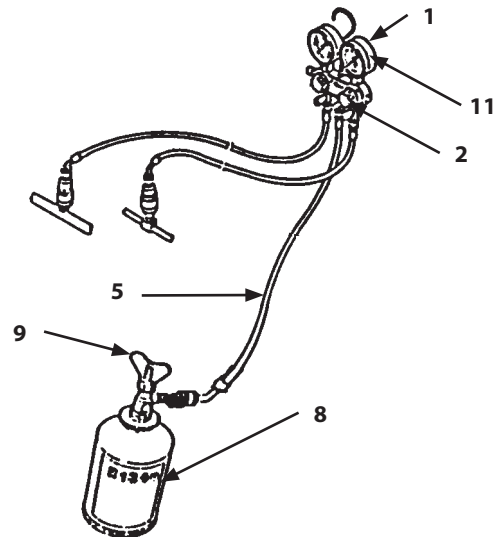

W115-02-10-007

IMPORTANT: Use the leak tester for R134a.

7. After charging, check the line connections for gas leaks using the leak tester.

CLICK HERE TO **DOWNLOAD** THE COMPLETE MANUAL

- Thank you very much for reading the preview of the manual.
- You can download the complete manual from: www.heydownloads.com by clicking the link below



- Please note: If there is no response to CLICKING the link, please download this PDF first and then click on it.

CLICK HERE TO **DOWNLOAD** THE COMPLETE MANUAL