

CLAAS

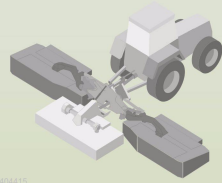

488410

DISCO

Technical systems

SERVICE & PARTS

CLICK HERE TO **DOWNLOAD** THE COMPLETE MANUAL

- Thank you very much for reading the preview of the manual.
- You can download the complete manual from: www.heydownloads.com by clicking the link below



- Please note: If there is no response to CLICKING the link, please download this PDF first and then click on it.

CLICK HERE TO **DOWNLOAD** THE COMPLETE MANUAL

2 DISCO 3000 TC, TRC, AS, FG - Hydraulic system

Hydraulic circuit diagram

Key to diagram

Pos.	Designation	Remark
1010	Oil tank	-
-	-	-
2070	Swath spreader pump	-
2071	Swath spreader motor	-
2072	Lubrication pump	-
-	-	-
3085	Chassis hydraulic cylinder	-
3169	Transport / working hydraulic cylinder	-
3189	Swath spreader hydraulic cylinder	-
-	-	-
6041	Shut-off valve	-
6085	Swath spreader shut-off valve	is actuated when raising the swath spreader
-	-	-
7034	Lock-up valve unit	-
7072	Volume flow controller	2 - 25 litres/min infinitely variable adjustment of swathing belt speed
-	-	-
8001	Quick release coupling	-
-	-	-
Y382	Swath spreader flow controller solenoid coil	-
-	-	-
a	Lock	Transport / working hydraulic cylinder
-	-	-
EW1	Single-acting	Tractor additional control unit. Raise - lower chassis.
EW2	Single-acting	Tractor additional control unit. Raise - lower swath spreader.
DA	Double-acting	Tractor additional control unit. Swing DISCO to working or transport position.

Working / transport position hydraulic cylinder (3169)

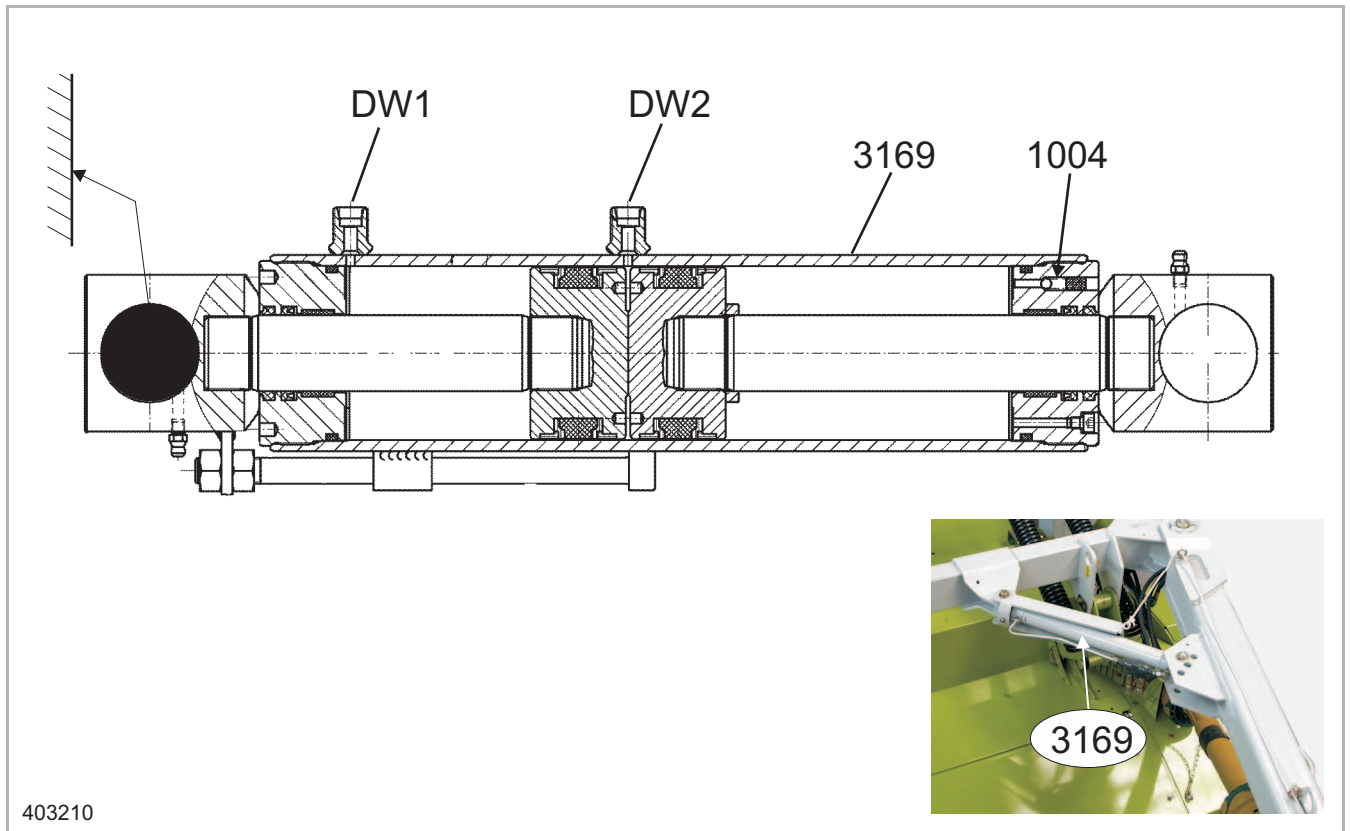

Pos.	Designation	Remark
1004	Vent opening	-
3169	Transport / working hydraulic cylinder	-
-	-	-
DA1	Port	Double-acting additional control unit on tractor
DA2	Plate	Double-acting additional control unit on tractor

Description of function

The working/transport position hydraulic cylinder (3169) folds the mower unit from the transport to the working position and vice versa. The combination of Single- and Double-acting function provides even folding without dead points and abrupt movements.

Working position on slopes

The hydraulic cylinder in the position shown at the top represents the mower unit in working position and tilted downward (slope).

Volume flow is fed via port DA1

for the turning area position

The complete cylinder travels until the left ram reaches the cylinder bottom.

Volume flow is fed via port DA2

for raising to transport position.

The right ram first extends up to the stop, in this process the mower unit is at an angle of about 90°. At the same time, but with a slight delay because of orifice plate 4009, the left ram travels up to the stop and the mower unit reaches a position of around 115°.

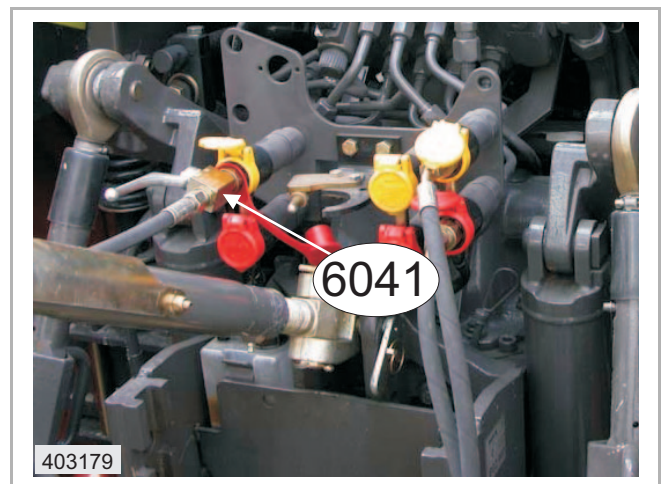
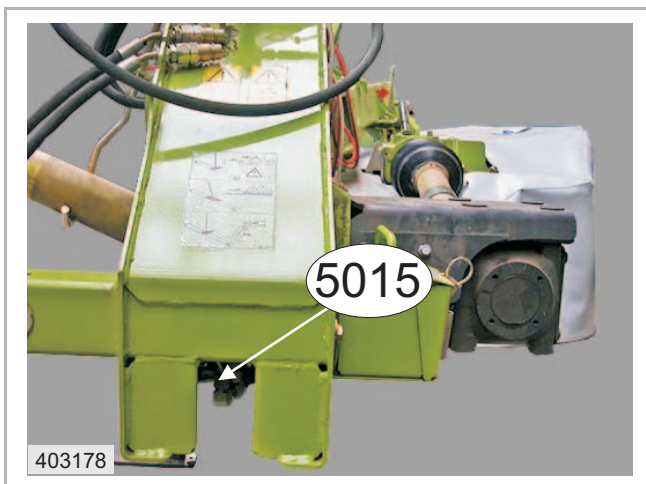
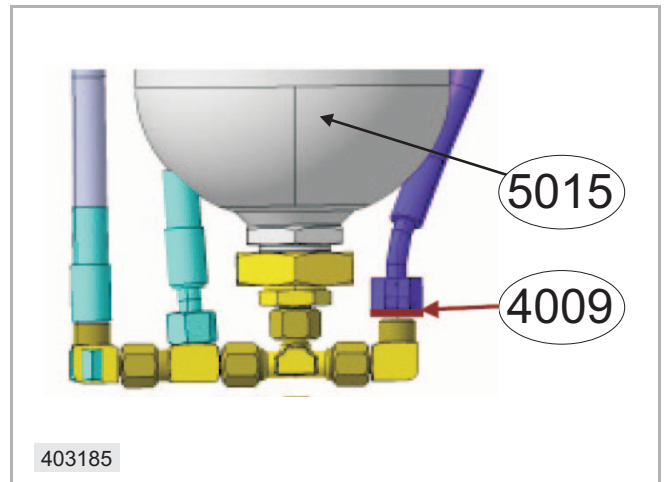
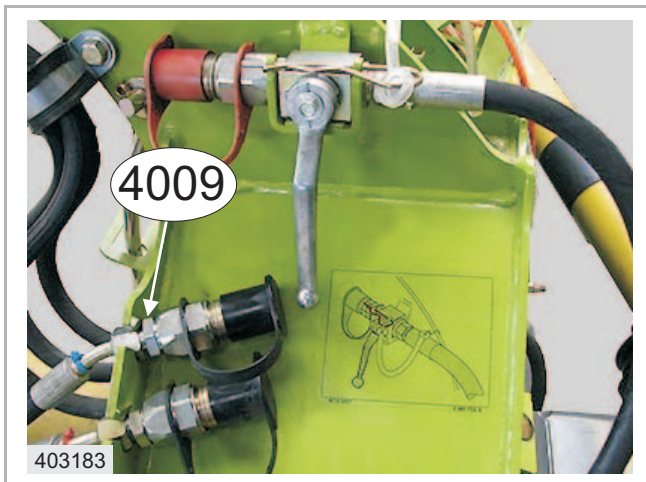

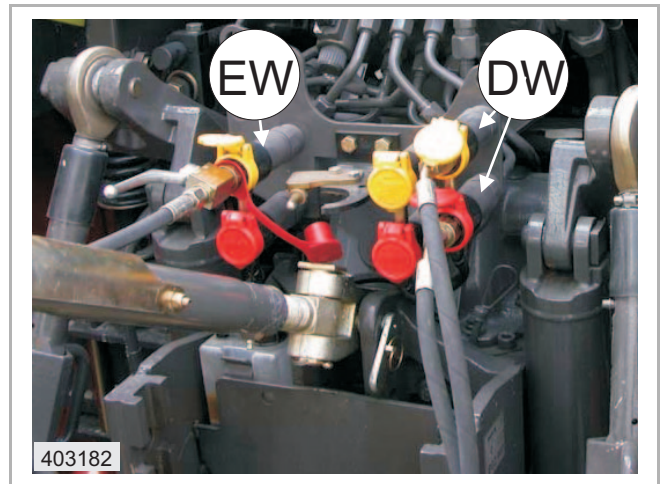
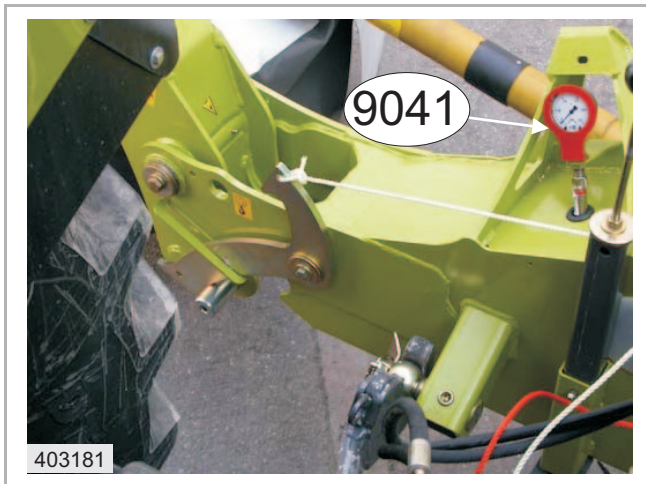
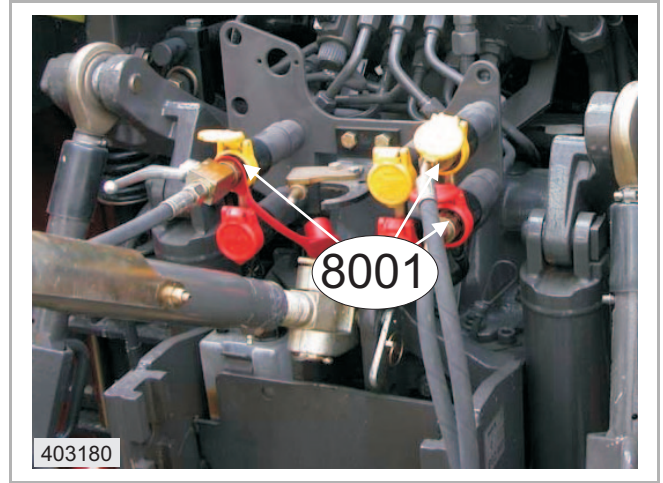
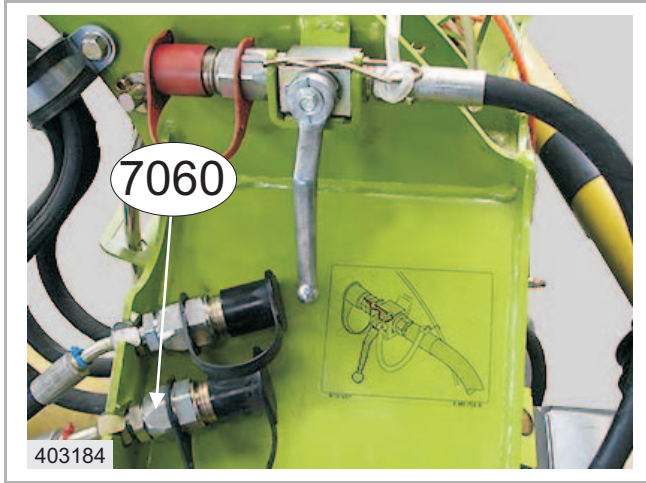

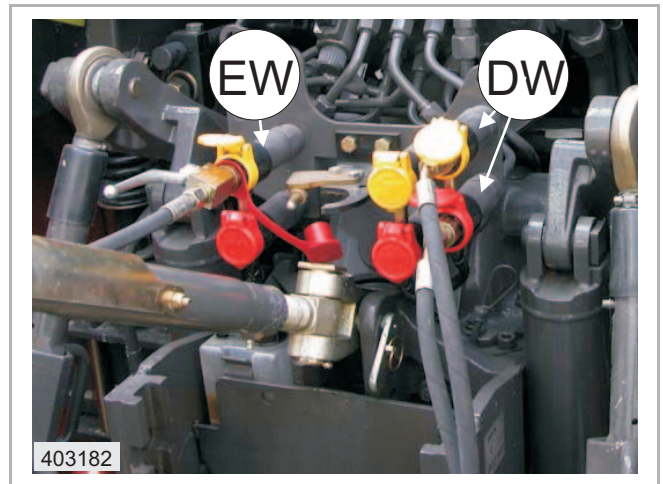
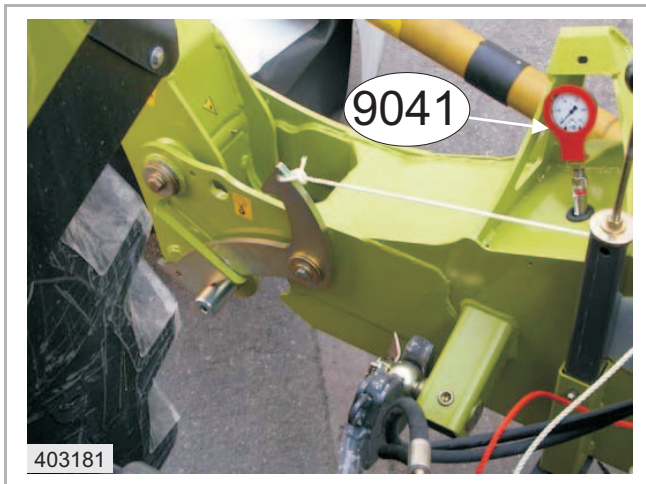
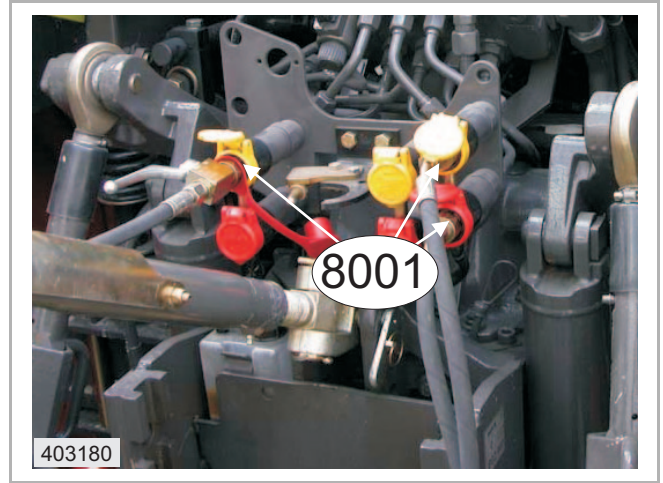
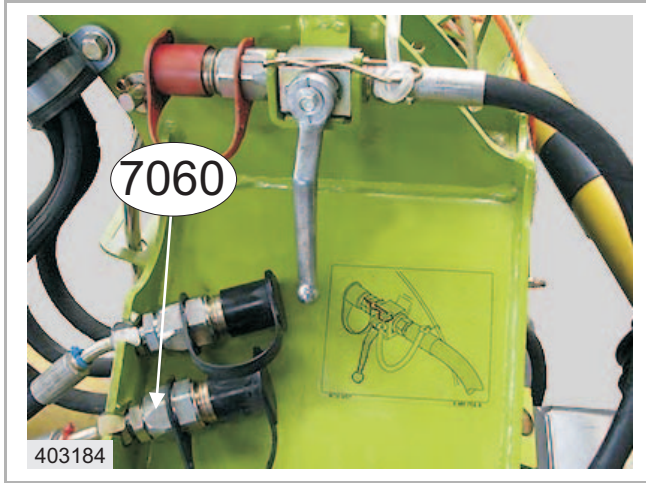

11 DISCO 8550 C Plus - Hydraulic system

Hydraulic circuit diagram

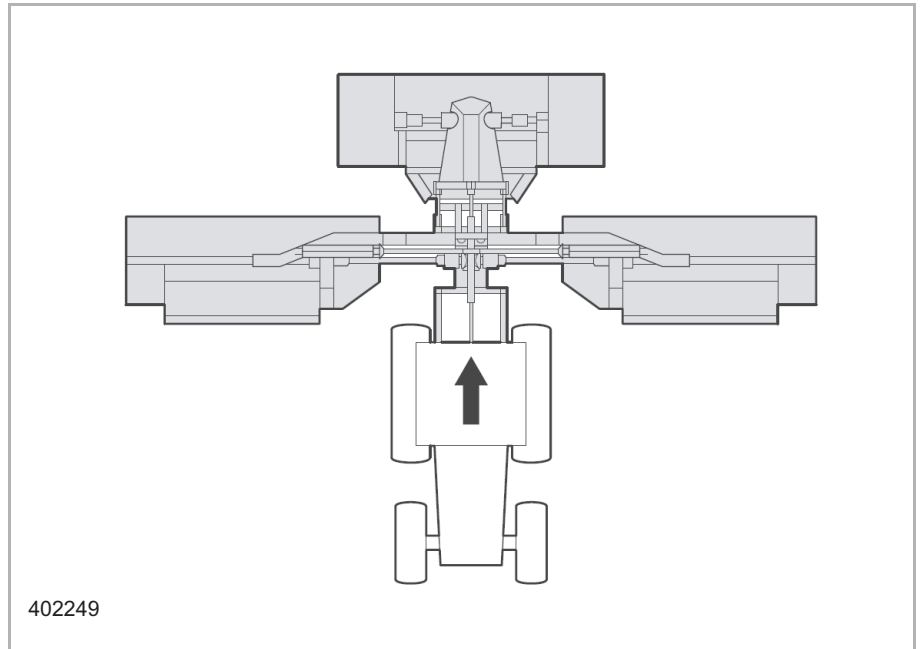

Malfunction

A sensor is defective (permanent minus at pin 3)

- Speed < 600 rpm: no warning
- Speed > 600 rpm: Warning light of defective sensor in CCT lights up and the warning tone sounds.

A sensor is defective (permanent minus at pin 3), or connector disconnected, or one sensor is without power supply.

- Speed < 600 rpm: The warning lights of the two intact sensors light up and the warning tone sounds.
- Speed > 600 rpm: no optical and acoustic warning.

Two sensors without power supply, or connector disconnected

- Speed < 600 rpm: The warning light of the intact sensor lights up and the warning tone sounds.
- Speed > 600 rpm: no optical and acoustic warning.

Three sensors without power supply, or connector disconnected

- Speed < 600 rpm: no warning
- Speed > 600 rpm: no warning

- Set potentiometers R44 and R45 to the value 1.5. The belts should run at the lower speed.



When the measured speed is way above 850 rpm or if the speed cannot be varied around approx. 400 rpm at the potentiometer, the following setting must be made:

Basic position

- Set switch T12 to „ON“
- Open the cover of module A72.

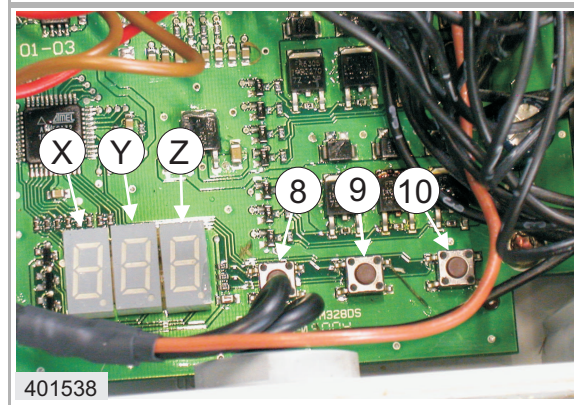
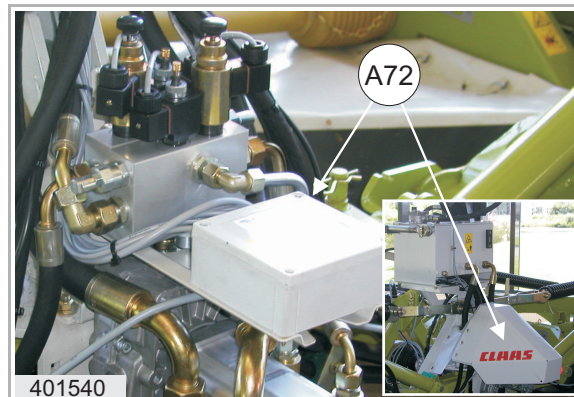

The LED display (Z) shows 3 horizontal bars.

Designations

Pos	Component	Coordi- nates
I	Left swath displacer hydraulic valve	
II	Right swath displacer hydraulic valve	
109	Oil cooler	
110	Oil tank	
112	Return filter	
256	Right swath displacer hydraulic pump (14.5 cm ³ /rev.)	
257	Left swath displacer hydraulic pump (14.5 cm ³ /rev.)	
258	Left swath displacer hydraulic motor (20 cm ³ , Danfoss OMM20, max. 25 ltr/min, n = 1250 rpm)	
259	Right swath displacer hydraulic motor (20 cm ³ , Danfoss OMM20, max. 25 ltr/min, n = 1250 rpm)	
706-1	Left swath displacer pressure relief valve (140 bar)	
706-2	Right swath displacer pressure relief valve (140 bar)	
787-1	Left swath displacer pressure balance	
787-2	Right swath displacer pressure balance	
Y258 (Y6.2)	Left swath displacer flow controller solenoid valve	
Y259 (Y7.2)	Right swath displacer flow controller solenoid valve	
A	Gearbox	

Emergency functions

In case of a fault in the electric system, the function of the swath displacers can be performed manually. To this end, switch (T12) must be set to „OFF“.

Danger!

 Danger of accident when operating the valves manually!

- Shut down the mower unit drive!
- Keep a sufficient distance from moving parts!

To supply the swath displacer hydraulic motors (258, 259) with volume flow, the PTO shaft of the tractor must be engaged.

The corresponding valves can be actuated by turning them in.

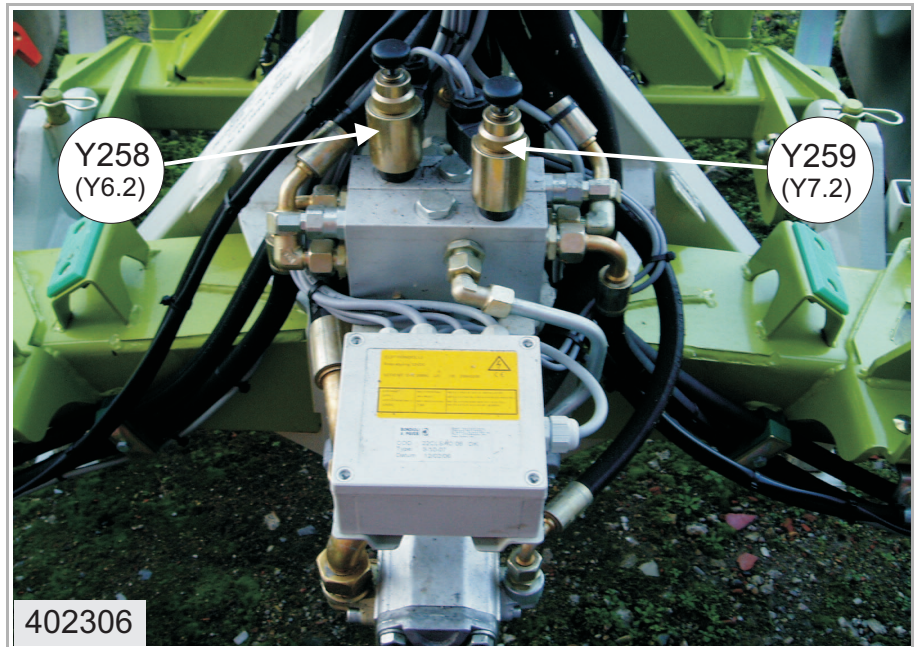

Left swath displacer flow controller solenoid valve (Y258) and right swath displacer flow controller solenoid valve (Y259): Turning in – The belt gets faster
 Turning out - The belt gets slower

CLICK HERE TO **DOWNLOAD** THE COMPLETE MANUAL

- Thank you very much for reading the preview of the manual.
- You can download the complete manual from: www.heydownloads.com by clicking the link below



- Please note: If there is no response to CLICKING the link, please download this PDF first and then click on it.

CLICK HERE TO **DOWNLOAD** THE COMPLETE MANUAL

When working, the working pressures of all cylinders are supported by accumulators 88, 98 and 102. Below 80 bar, the lock-up valve units are open at switch 94. When the pressure rises above 85 bar, the lock-up valve units are closed and the mower units remain in their position. The ground pressure of the mower units can be read on the pressure gauges 87, 97 and 101.

Central terminal compartment

Graphics

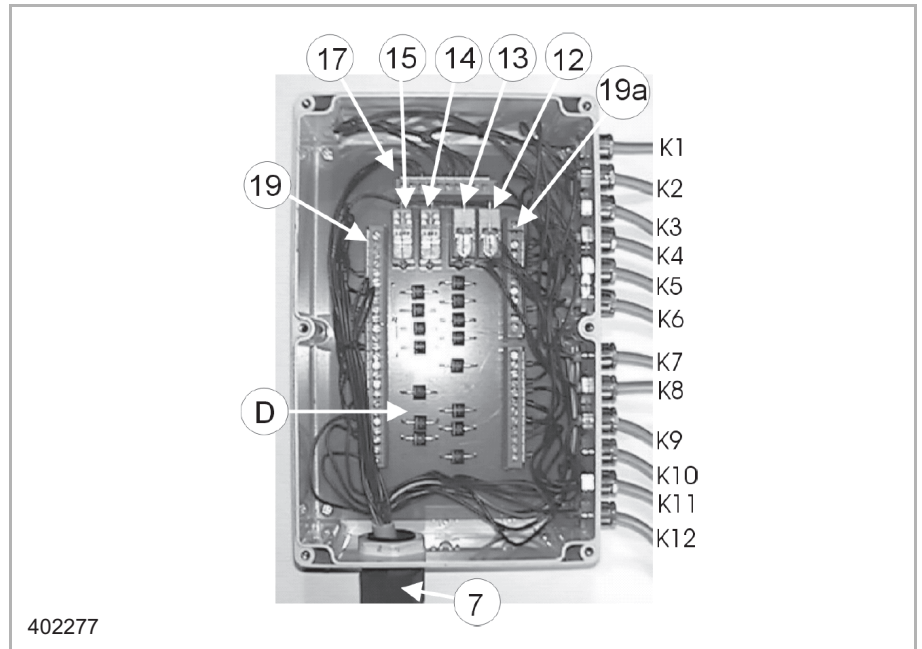

Key to diagram

Pos.	Designation	Remark
7	Connector	Central terminal compartment
12	Relay	for lock-up valve unit 89 and 99
13	Relay	for 4/3-way solenoid valve (item 50A)
14	Relay	for 4/3-way solenoid valve (item 50B)
15	Relay	for lock-up valve unit item 109
17	Terminal strip, plus	in the central terminal compartment (located above the relays)
19	Terminal strip, left	-
19a	Terminal strip, right	-
-	-	-
d	Diodes	-
K1	Raise/lower right side-mounted mower unit	Solenoid valve item 74
K2	Raise/lower left side-mounted mower unit	Solenoid valve item 73
K3	Front mower unit	Solenoid valve item 72
K4	Right mower unit lock-up valve unit	Solenoid valve item 89
K5	Left mower unit lock-up valve unit	Solenoid valve 99

Key to diagram

Pos.	Designation	Remark
10	Quick release coupling	-
11	Quick release coupling	Tank connection
12	Mower units pressure gauge	L=left R=right M=centre
13	Accumulator	0.16 ltr. 80 bar
14	3 accumulators	0.75 ltr. 35 bar
15	3 accumulators	0.75 ltr. 35 bar
16	3 accumulators	0.75 ltr. 35 bar
17	Non-return valves	-
18	Non-return valves	-
19a	Left mower unit cylinder	raise/lower
19b	Right mower unit cylinder	raise/lower
20a	Centre mower unit cylinder	raise/lower
20b	Centre mower unit cylinder	raise/lower
21	Pressure relief valve	(210 bar) Starting protection of left mower unit
22	Pressure relief valve	(210 bar) Starting protection of right mower unit
23	Pressure relief valve	(180 bar) Front attachment cylinder ram ring surface
24a	Fold left mower unit cylinder in/out	and cylinder starting protection
24b	Right mower unit cylinder	and cylinder starting protection
DS1	Pressure switch	(85/110 bar) Raise front attachment
DS2	Pressure switch	(140 bar) Close left accumulator
DS3	Pressure switch	(140 bar) Close right accumulator
DS4	Pressure switch	(150 bar) Fold in mower units
DS5	Pressure switch	(150 bar) Fold out mower units
M1	Solenoid valve	Swing out mower units
M2	Solenoid valve	Swing in mower units
M3	Solenoid valve	Raise/lower left mower unit
M4	Solenoid valve	Raise/lower centre mower unit
M5	Solenoid valve	Raise/lower right mower unit
M6	Solenoid valve	Left accumulator shut-off valve
M7	Solenoid valve	Front accumulator shut-off valve
M8	Solenoid valve	Right accumulator shut-off valve
M9	Solenoid valve	Raise/lower left load relief valve
M10	Solenoid valve	Raise/lower front load relief valve

Overall circuit diagram from serial no. 492 00 513

Key to diagram

Pos.	Designation	Remark
A33	Control box	for JAGUAR Types 491 and 492
CCT	CLAAS Control Terminal	-
CT	Connector	Connection to CLAAS Control Terminal (CCT)
DS1	Pressure switch	85/110 bar, NO contact, raise front attachment
DS2	Pressure switch	140 bar, NO contact, left mower unit (close accumulator) pressure switch
DS3	Pressure switch	140 bar, NO contact, right mower unit (close accumulator)
DS4	Pressure switch	150 bar, NO contact, fold side-mounted mower units in/out
DS5	Pressure switch	150 bar, NO contact, lower front mower unit, fold out mower units
DZWL	Speed monitor	DA60 (supplier: Walterscheid), left mower unit
DZWM	Speed monitor	DA60 (supplier: Walterscheid), front mower unit
DZWR	Speed monitor	DA60 (supplier: Walterscheid), right mower unit
H	Connector	beneath the cab
M	Connector	in the central terminal compartment (only on JAGUAR Type 492)
MFG	Multifunction handle	-
M1	Swing out mower units solenoid valve	-
M2	Swing in mower units solenoid valve	-
M3	Raise/lower left mower unit solenoid valve	-
M4	Raise/lower centre mower unit solenoid valve	-
M5	Raise/lower right mower unit solenoid valve	-
M6	Left accumulator shut-off valve solenoid valve	-
M7	Front accumulator shut-off valve solenoid valve	-
M8	Right accumulator shut-off valve solenoid valve	-
M9	Raise/lower left load relief valve solenoid valve	-
M10	Raise/lower front load relief valve solenoid valve	-
M11	Raise/lower right load relief valve solenoid valve	-
M12	Lower overall pressure load relief valve solenoid valve	-

**20 DISCO 8700 Plus, DISCO 8550 C-8
for JAGUAR 880-820 (491) - Hydraulic system**
Overall circuit diagram

10 Electric system main group

Module A068 - Connector X2

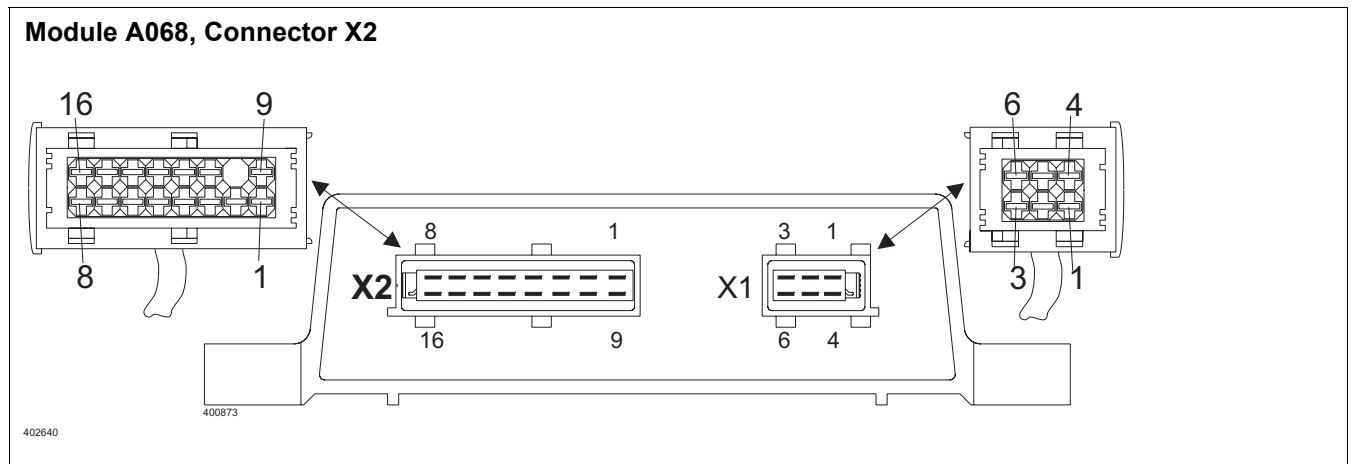

Pin	Function	CCN	Component	Circuit diagram	Measured variable	Direction
2/1	Power plus	+30	Power plus	1	12 V	Input
2/2	Right mower unit height block valve	Y415	Solenoid coil	1	12 V	Output
2/3	Individual right mower unit lifting	Y413	Solenoid coil	1	12 V	Output
2/4	Left mower unit height block valve	Y414	Solenoid coil	1	12 V	Output
2/5	Individual left mower unit lifting	Y412	Solenoid coil	1	12 V	Output
2/6	Right mower unit load relief	Y408	Solenoid coil	1	12 V	Output
2/7	Left mower unit load relief	Y407	Solenoid coil	1	12 V	Output
2/8	Power earth	-31	Power earth	1	Ground	Input
2/9	-	-	-	-	-	-
2/10	Mower unit pressure sensor	B296	Sensor	1	0.25 - 4.75 V	Input
2/11	-	-	-	-	-	-
2/12	-	-	-	-	-	-
2/13	-	-	-	-	-	-
2/14	-	-	-	-	-	-
2/15	-	-	-	-	-	-
2/16	-	-	-	-	-	-

Designations

Pos	Component	Coordinates
3016	Safety frame hydraulic cylinder	Pressure build-up in the piston top space = transport position Pressure build-up in the rod space = working position
3132	Left mower unit hydraulic cylinder	Pressure build-up in the piston top space = raise left mower unit.
3133	Right mower unit hydraulic cylinder	Pressure build-up in the piston top space = raise right mower unit.
3148	Front mower unit hydraulic cylinder	Pressure build-up in the piston top space = raise front mower unit.
3195	Left mower unit load relief hydraulic cylinder	Pressure build-up in the piston top space = increase load relief of left mower unit.
3196	Right mower unit load relief hydraulic cylinder	Pressure build-up in the piston top space = increase load relief of right mower unit.
3197	Front mower unit load relief hydraulic cylinder	Pressure build-up in the piston top space = increase load relief of front mower unit.
-	-	-
4004	Plate	Ø 0.4mm
4005	Plate	Ø 0.6mm
4008	Plate	Ø1.2 mm
4009	Plate	Ø 0.9mm
4011	Plate	Ø 1.8mm
4012	Plate	Ø 2.0mm
4034	Plate	Ø 3.0mm
-	-	-
5015	Accumulator	0.32 litres. Energy reserve for keeping the mower unit in transport position.
5027	Left mower unit load relief accumulator	0.75 litres, 3 pc.
5028	Right mower unit load relief accumulator	0.75 litres, 3 pc.
5029	Front mower unit load relief accumulator	0.75 litres, 4 pc.
-	-	-
7032	Non-return valve	
7063	Input pressure balance	- provides neutral circulation connection from pressurised oil supply (P1) to the tank (T) when no consumer is actuated. - blocks the neutral circulation _ connection from (P1) to the tank (T) when a consumer is actuated.
7172	Pump shut-off valve	is opened when a consumer is actuated.

Pos	Component	Coordinates
7173	Tank shut-off valve	The piston is opened by the return pressure against the compression spring (0.4bar) in the ring space.
-	-	-
9001	Working hydraulics measuring point	Corn picker connection Neutral circulation pressure (no consumer is actuated): about 15 bar at an oil temperature of around 40°C
9041	Ground pressure gauge	
-	-	-
B278	Front mower unit pressure sensor	-
-	-	-
Y077	Working hydraulics master valve solenoid coil	is energised at the same time as solenoid valves Y406, Y407, Y408, Y409, Y288, Y410 and Y411, in this process: - the spring space of the pump shut-off valve (7172) is connected with the tank - the valve piston opens the connection with the solenoid valves Y407, Y408, Y409, Y288, Y410 and Y411. - pressurised oil (P1) flows into the spring space of the tank shut-off valve (7173) - the valve piston closes the connection to the tank (T).
Y288	Front mower unit solenoid coil	
Y406	Safety frame fold in/out solenoid coil	Solenoid valve energised: Working position of safety frame hydraulic cylinder (3016) Solenoid valve not energised: Transport position of safety frame hydraulic cylinder (3016)
Y407	Left mower unit load relief solenoid coil	Solenoid valve energised: Hydraulic oil flows into the piston top space of the left mower unit load relief hydraulic cylinder (3195) = Increase of mower unit load relief. Solenoid valve not energised: Closed position of left mower unit load relief hydraulic cylinder (3195).
Y408	Right mower unit load relief solenoid coil	Solenoid valve energised: Hydraulic oil flows into the piston top space of the right mower unit load relief hydraulic cylinder (3196) = Increase of mower unit load relief. Solenoid valve not energised: Closed position of right mower unit load relief hydraulic cylinder (3196).
Y409	Front mower unit load relief solenoid coil	Solenoid valve energised: Hydraulic oil flows into the piston top space of the front mower unit load relief hydraulic cylinder (3197) = Increase of mower unit load relief. Solenoid valve not energised: Closed position of front mower unit load relief hydraulic cylinder (3197).
Y410	Solenoid coil of left mower unit changeover P1-P2	is energised for raising and lowering the left mower unit hydraulic cylinder (3132); at the same time, the left mower unit LS priority solenoid valve (Y410) is energised. Solenoid valve not energised: Closed position of left mower unit hydraulic cylinder (3132).

Designations

Pos	Component	Coordinates
3016	Safety frame hydraulic cylinder	Pressure build-up in the piston top space = transport position Pressure build-up in the rod space = working position
3132	Left mower unit hydraulic cylinder	Pressure build-up in the piston top space = raise left mower unit.
3133	Right mower unit hydraulic cylinder	Pressure build-up in the piston top space = raise right mower unit.
3195	Left mower unit load relief hydraulic cylinder	Pressure build-up in the piston top space = increase load relief of left mower unit.
3196	Right mower unit load relief hydraulic cylinder	Pressure build-up in the piston top space = increase load relief of right mower unit.
-	-	-
4004	Plate	Ø 0.4mm
4008	Plate	Ø1.2 mm
4009	Plate	Ø 0.9mm
4011	Plate	Ø 1.8mm
4012	Plate	Ø 2.0mm
4034	Plate	Ø 3.0mm
-	-	-
5015	Accumulator	0.32 litres. Energy reserve for keeping the mower unit in transport position.
5027	Left mower unit load relief accumulator	0.75 litres, 3 pc.
5028	Right mower unit load relief accumulator	0.75 litres, 3 pc.
5029	Front mower unit load relief accumulator	0.75 litres, 4 pc.
-	-	-
7032	Non-return valve	
7063	Input pressure balance	- provides the neutral circulation connection from pressurised oil supply (P1) to the tank (T) when no consumer is actuated. - blocks the neutral circulation _ connection from (P1) to the tank (T) when a consumer is actuated.
7172	Pump shut-off valve	is opened when a consumer is actuated.
7173	Tank shut-off valve	The piston is opened by the return pressure against the compression spring (0.4bar) in the ring space.
-	-	-
9001	Working hydraulics measuring point	Corn picker connection Neutral circulation pressure (no consumer is actuated): about 15 bar at an oil temperature of around 40°C

Pos	Component	Coordinates
9041	Ground pressure gauge	
-	-	-
B278	Front mower unit pressure sensor	detects the pressure while raising and lowering the front mower unit - with pressurised oil supply via port (P2) and in this process controls the lifting movements of all mower units on the headland: When the front mower unit is raised on the headland, the pressure rises. At a pressure signal of >0.65 Volt, the solenoid valves of the mower unit (Y416), the left mower unit (Y412) and the right mower unit (Y413) are de-energised - they go to the closed position for stopping the lift of the mower units. When the front mower unit is lowered to the working position on the headland, the pressure falls. At a pressure signal of <0.65 Volt, the solenoid valves of the left mower unit (Y412) and the right mower unit (Y413) are energised - they go to the open position for lowering the mower units.
-	-	-
Y077	Working hydraulics master valve solenoid coil	is energised at the same time as solenoid valves Y406, Y407, Y408, Y409, Y288, Y410 and Y411, in this process: - the spring space of the pump shut-off valve (7172) is connected with the tank - the valve piston opens the connection with the solenoid valves Y407, Y408, Y409, Y288, Y410 and Y411. - pressurised oil (P1) flows into the spring space of the tank shut-off valve (7173) - the valve piston closes the connection to the tank (T).
Y406	Safety frame fold in/out solenoid coil	Solenoid valve energised: Working position of safety frame hydraulic cylinder (3016) Solenoid valve not energised: transport position of safety frame hydraulic cylinder (3016)
Y407	Left mower unit load relief solenoid coil	Solenoid valve energised: Hydraulic oil flows into the piston top space of the left mower unit load relief hydraulic cylinder (3195) = Increase of mower unit load relief. Solenoid valve not energised: Closed position of left mower unit load relief hydraulic cylinder (3195).
Y408	Right mower unit load relief solenoid coil	Solenoid valve energised: Hydraulic oil flows into the piston top space of the right mower unit load relief hydraulic cylinder (3196) = Increase of mower unit load relief. Solenoid valve not energised: Closed position of right mower unit load relief hydraulic cylinder (3196).
Y409	Front mower unit load relief solenoid coil	Solenoid valve energised: Hydraulic oil flows into the piston top space of the front mower unit load relief hydraulic cylinder (3197) = Increase of mower unit load relief. Solenoid valve not energised: Closed position of front mower unit load relief hydraulic cylinder (3197).

Designations

Pos	Component
A068	Mower unit control module
A111	Mower unit control additional module
X1	Connector
X2	Connector

CLICK HERE TO **DOWNLOAD** THE COMPLETE MANUAL

- Thank you very much for reading the preview of the manual.
- You can download the complete manual from: www.heydownloads.com by clicking the link below



- Please note: If there is no response to CLICKING the link, please download this PDF first and then click on it.

CLICK HERE TO **DOWNLOAD** THE COMPLETE MANUAL