

A0 – INJECTION SHEET CHECKING PROCEDURE



A1 – INJECTION FEED



A2 – ENGINE TIER II



Ares 806

Chapter A

60 05 030 493 – 09.2004 publication

CLICK HERE TO **DOWNLOAD** THE COMPLETE MANUAL

- Thank you very much for reading the preview of the manual.
- You can download the complete manual from: www.heydownloads.com by clicking the link below



- Please note: If there is no response to CLICKING the link, please download this PDF first and then click on it.

CLICK HERE TO **DOWNLOAD** THE COMPLETE MANUAL



Measurement sheet

This sheet is intended to be duplicated and completed for each operation on the tractor. If you have to send it to the manufacturer's after sales service, it is essential to indicate:

Tractor type:

Serial n°:

Engine serial n°:

Total operating hours:

Date of operation:

Transmission type:

	Start of test	End of test	Reference values (bar)
Hydraulic pressure in HP circuit			See appendix
Hydraulic pressure in LP circuit			
Outside temperature			—
Transmission temperature			60 °C → 65 °C
Engine temperature			> 87 °C
Diesel temperature			

Engine speed	1 000	1 100	1 200	1 300	1 400	1 500	1 600	1 700	1 800	1 900	2 000	2 100	2 200
Measurement (kW)													
Measurement (N.m). (power take-off)													
Measurement (l/h)													
Measurement of boost pressure (bar)													
Measurement of diesel supply pressure at filter outlet (bar)													
Boost pressure (bar) Ares 816	0,36	0,39	0,51	0,65	0,79	0,85	0,87	0,91	0,94	0,97	1,02	1,04	1,00
Boost pressure (bar) Ares 826	0,39	0,50	0,66	0,87	1,05	1,16	1,21	1,27	1,32	1,36	1,40	1,40	1,37
Boost pressure (bar) Ares 836	—	0,47	0,61	0,78	0,93	1,02	1,13	1,21	1,23	1,24	1,23	1,22	1,18
Diesel supply pressure at filter outlet (bar) Ares 816-826	0,25 → 0,30												
Diesel supply pressure at filter outlet (bar) Ares 836	0,50												



A1 – INJECTION FEED

Engine DPS 6068 HRT 70

Engine DPS 6068 HRT 71

Engine DPS 6068 HRT 72

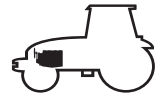

Checks/Adjustments

Adjusting the engine injector

For any operation assembling/dismantling the injectors, use tool n° 60 05 005 579 combined with a sliding hammer.

- Unscrew the protection cover (F).
- Loosen and remove the locking nut (A) of the needle rise adjustment screw.
- Loosen locking nut (C) of the injection pressure adjustment screw, use tool n° 60 05 005 574.
- Connect the injector to the tester then adjust the pressure to the specified value by turning the pressure adjustment screw (D).
- Tighten the locknut (A) and check the pressure.

Carry out the adjustment again if necessary.

WARNING: It is recommended to aim for the maximum value in the adjustment because after operating for some time the pressure drops slightly before stabilising. Repeat the adjustment in order to obtain a reliable result.

- Gently turn the needle rise adjustment screw (B) until it reaches the seat of the spring (E).
- Unscrew the needle rise adjustment screw a 7/8 turn.
- Tighten the locknut (A) at torque.

WARNING: The injector nozzle must never be pointing towards the person performing the adjustment. The jet escaping from a port can pierce clothing and skin, and cause serious infections. It is recommended to contain the jet within a transparent container.

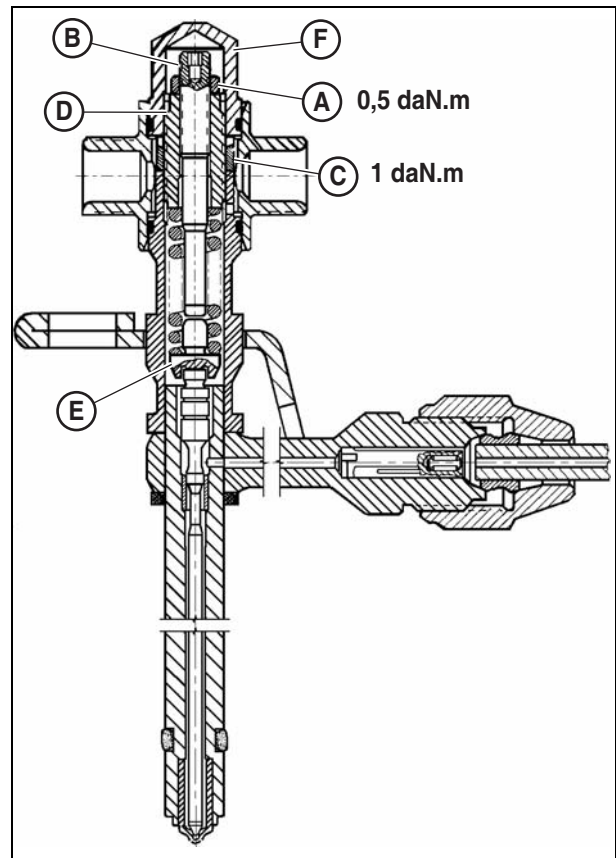

161msm06



A2 – ENGINE TIER II

Engine DPS 6068 HRT 70

Engine DPS 6068 HRT 71

Engine DPS 6068 HRT 72

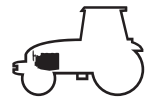

General specifications

Lubrication

Oil pump

- Oil pump delivery at maximum speed, at 3 bar pressure 70 l/min
- Minimum oil pressure at tick-over, with the oil at 90°C 1 bar minimum
- Minimum oil pressure at maximum off-load speed, with the oil at 90°C
- All engine types 3 bar minimum
- Bypass valve spring.
- Spring length (off-load) 51 mm
- Spring force at a length of 29 mm 8,7 daN

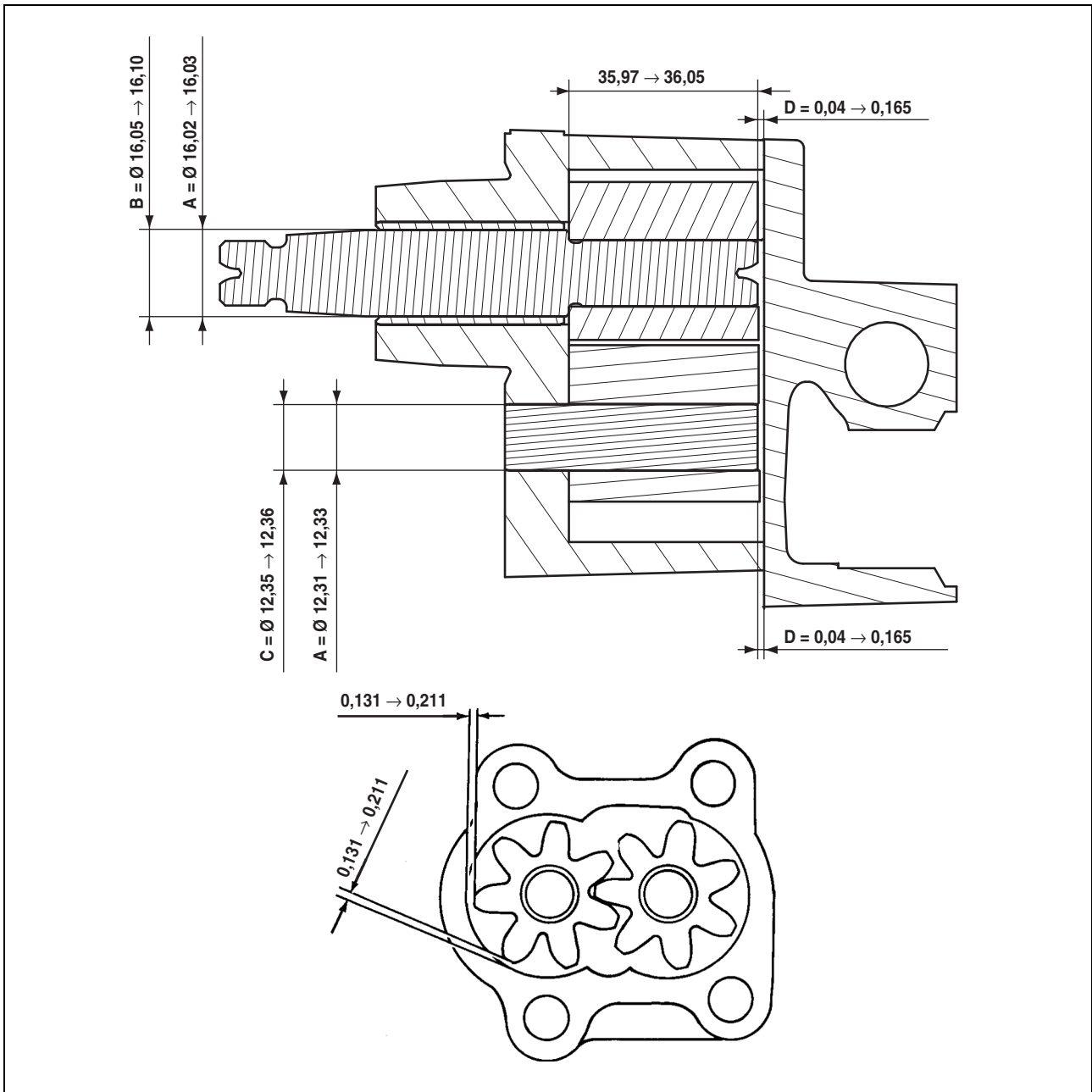

220hsm00

Fig. 12

Parts list

A Shaft.

B Bush.

C Bore.

D Axial clearance.

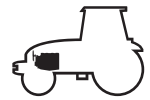

Removal/refitting

Preliminary operations

Cab

- Apply the handbrake.
- Set the gearbox lever to neutral.

Electricity

- Disconnect the battery.

Sheet metal elements

- Remove the lateral, frontal and upper covers.
- Remove the exhaust pipe (according to the engine type).
- Remove the exhaust/battery support assembly*.

Transmission shaft

- Remove the protective casing.
- Disconnect and remove the transmission shaft.

Drains

(according to intervention)

- Drain the cooling system.
- Drain the engine casing.

Front weights

- Remove the removable ballast weights.

Tractor adjustment

- Chock the rear wheels.
- Neutralize the tilt angle by fixing the front axle.

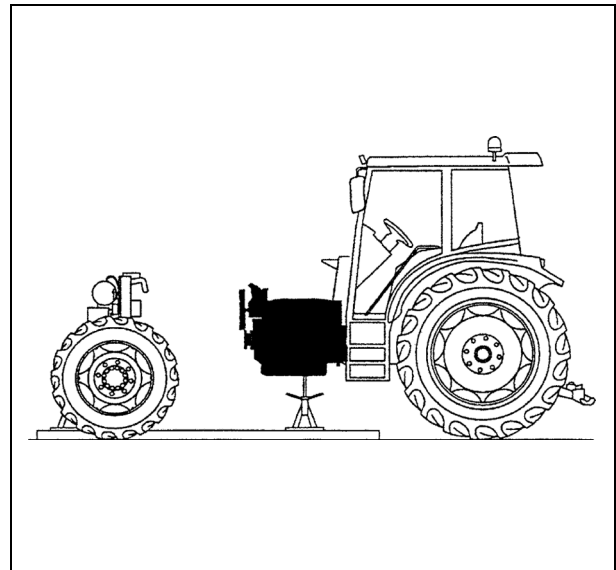

101hsm02

Fig. 33

* According to equipment.



Removal/refitting

Liners

Disassembling the liners

Important: Before disassembly, number the liners and the pistons. Mark the **FRONT** part of the liner to ensure its proper reassembly position.

Extract the liners from the cylinder block using tool n° 60 05 005 504 (1).

Important: After removing the cylinder head, never turn the crankshaft unless all the liners are held (C) using bolts (A) and washers (B).

Checking the ovalization and tapering of the liners

Refer to the chapter "Dimensional specifications".

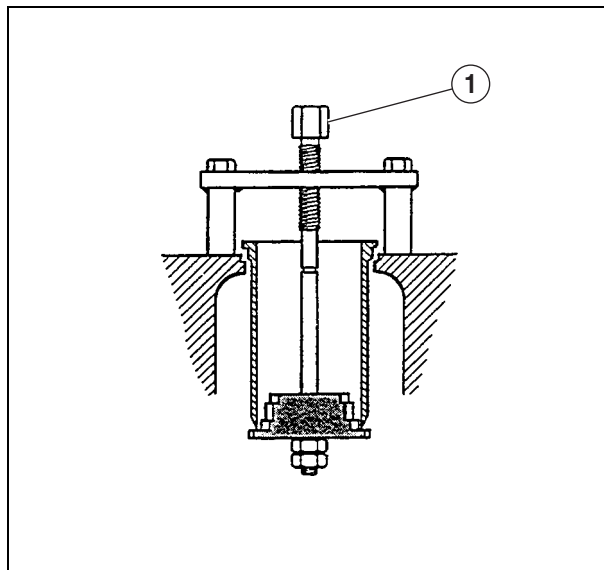

120hsm00

Fig. 63

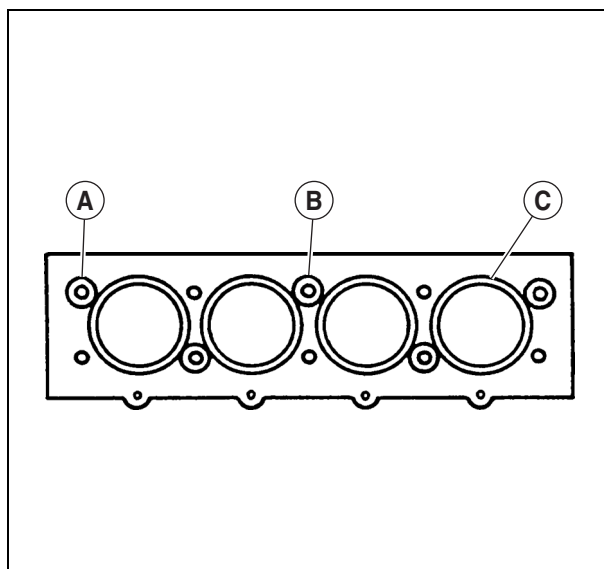

120hsm01

Fig. 64

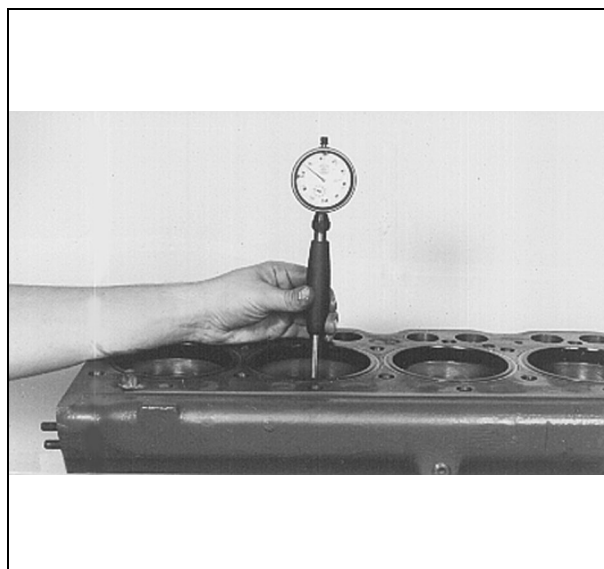

120hsm02

Fig. 65

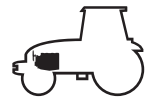

Removal/refitting

Removing the flywheel

1 Remove the two securing screws and replace them with studs (1), then remove the other securing screws.

N.B.: Build locally with two screws reference n° 60 05 021 489 and 2 studs.

2 Insert 2 screws (reference n° 60 05 021 489) into the tapped holes (A) to push the flywheel off the crankshaft and simplify handling.

Note: As the flywheel is heavy, appropriate lifting equipment is required to prevent accidents.

Changing the flywheel ring gear

1 Extract the ring gear from the flywheel using a brass drift and a hammer.

2 Heat the new ring gear to 150 °C in an oil bath, in an appropriate oven or using a flame.

Note: The oil and oil vapours are flammable from 190°C. Use a thermometer to ensure that a temperature of 180°C is not exceeded. Heat the oil in a well ventilated room. Beware when handling hot oil: Danger of burns !

Important: If heated using a flame, check that the heat is applied evenly over the entire circumference of the ring gear.

3 Shrink on the ring gear to fit it correctly onto the flywheel shoulder. The edge (A) of the teeth must be turned towards the engine.

N.B.: Check that the ring gear is supported all around the flywheel shoulder.

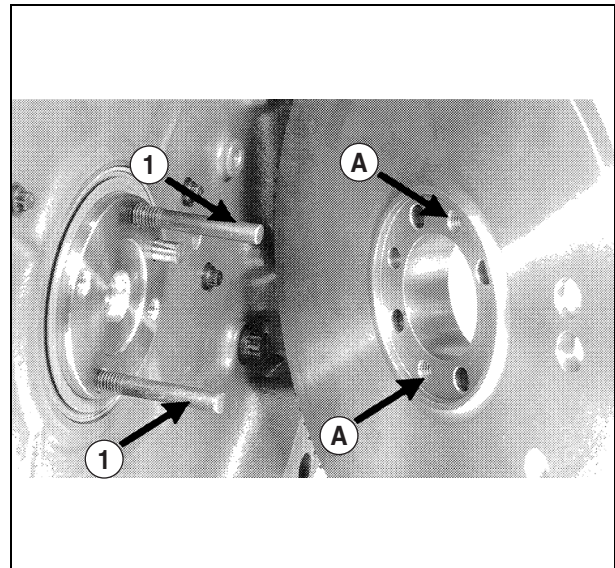

121hsm22

Fig. 96

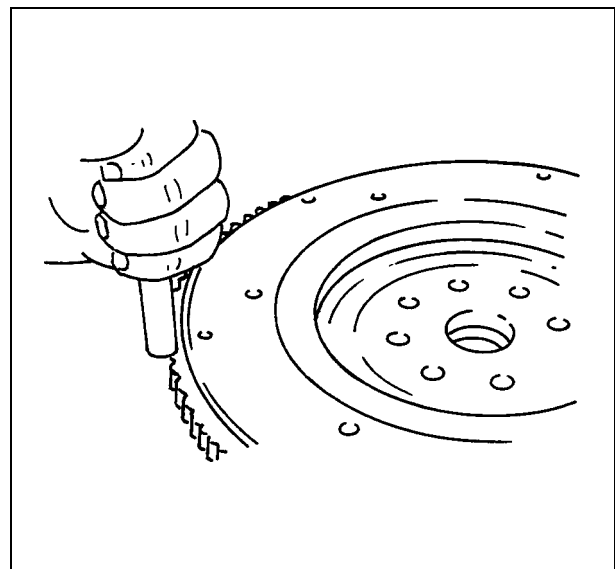

121hsm23

Fig. 97

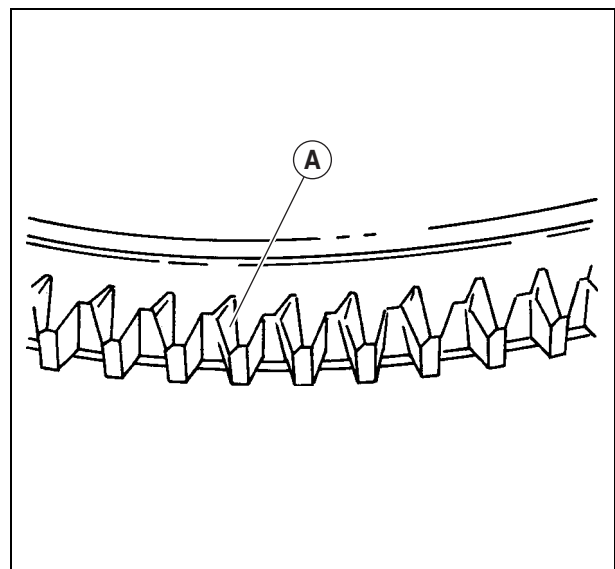

121hsm24

Fig. 98

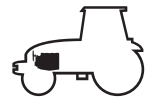

Removal/refitting

Assembling the lower distribution

- 1 Bring piston n° 1 to TDC using flywheel rotator n° 60 05 005 501 and adjustment pin n° 60 05 005 576.
- 2 Fit the oil pump and the balancer shafts.
- 3 Turn the right-hand balancer shaft until mark (A) is aligned with timing tool n° 60 05 005 511 (1).
- 4 Fit the lower intermediate pinion without turning the balancer shaft.

N.B.: Fit the stop washer while turning the "X" mark in the opposite direction to the pinion.

Tighten the bolt to 7 daN.m (oil the bolt).

Repeat operation 3 with the left-hand balancer shaft.

Fit the oil pump pinion on its shaft. Tighten the nut to 5 daN.m and lock it with 3 punches.

Check the timing of the two balancer shafts again.

Important: When adjusting the balancer shafts, the key groove on the shafts must be in the high position (12 o'clock), with the 2 pinion marks turned inwards towards the end of the crankshaft.

Fitting the distributor casing

- 1 Check that the casing gasket faces and the front plate are clean.
- 2 Fit the cover (C) providing access to the injection pump pinion using a new seal (D) if required. Tighten the screws to 0,6 daN.m.
- 3 Install the gasket seal (A) and cut it in the lower part to ensure it contacts the oil casing seal.
- 4 Install the distributor casing (B). Smear the bolt (E) with sealing compound. Tighten the bolts and nuts to 3,5 daN.m.

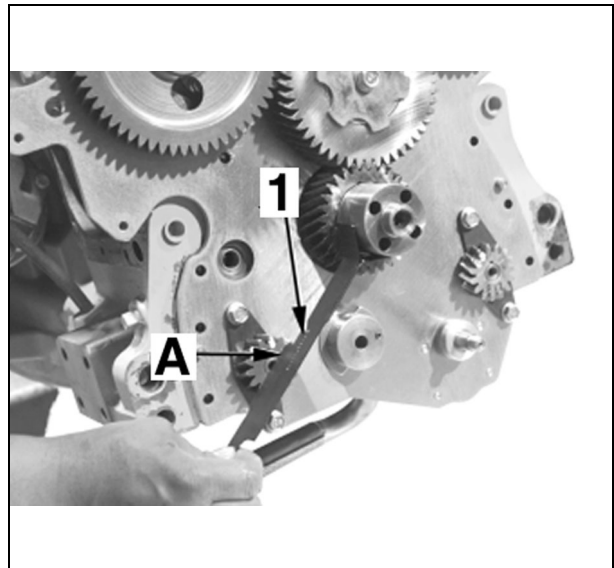

111hsm28

Fig. 134

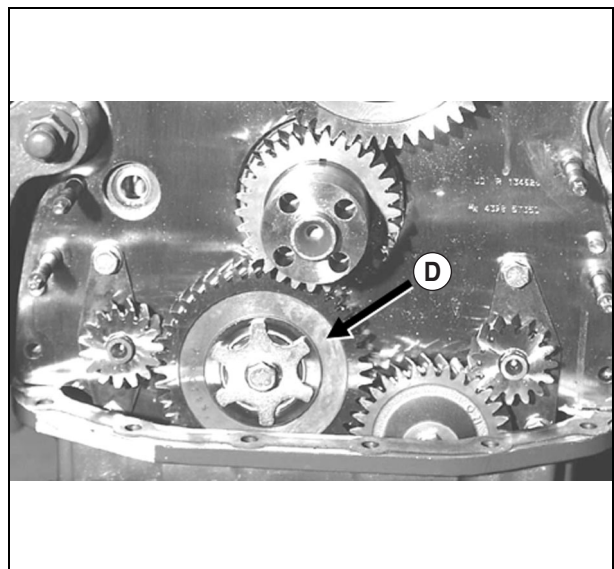

111hsm29

Fig. 135

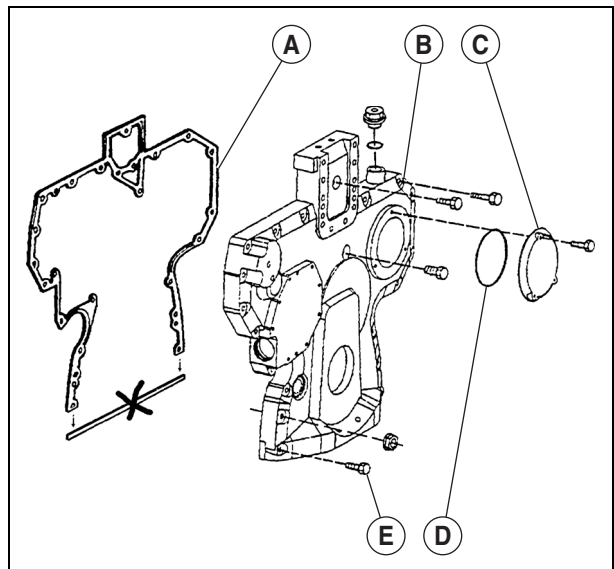

111hsm30

Fig. 136

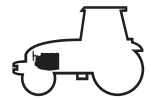

Removal/refitting

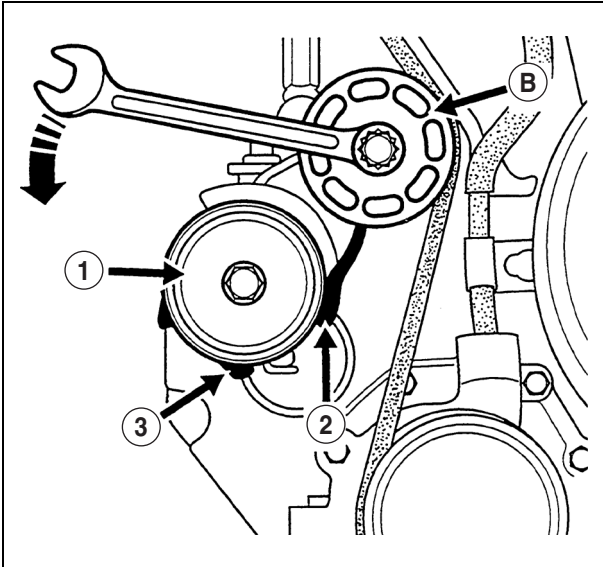

251hsm20

Fig. 167

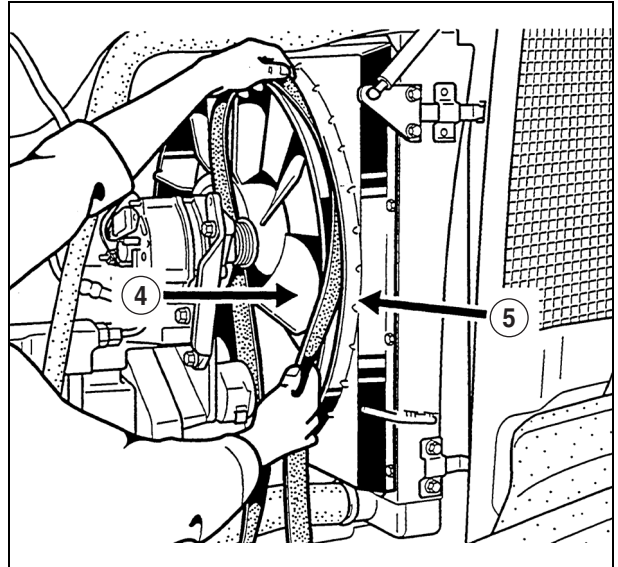

251hsm21

Fig. 168

Changing the drive belt

1 Inspect the moulded end pieces (2) and (3) on the belt tensioner (1).

2 If the stop (2) on the tensioner swivel arm contacts the fixed stop (3), check the condition of the various pulleys on which the belt passes. If the pulleys seem normal, replace the belt.

3 To change, loosen the belt tension using a wrench placed on the pulley (B).

4 Remove the old belt from the pulleys, then cut it.

5 Slip the new belt between fan (4) and the cooling nozzle (5).

6 Install the new belt so that it passes correctly over all the pulleys (see drawing opposite).

7 Tighten the belt with the tensioner (B). Remove the wrench.

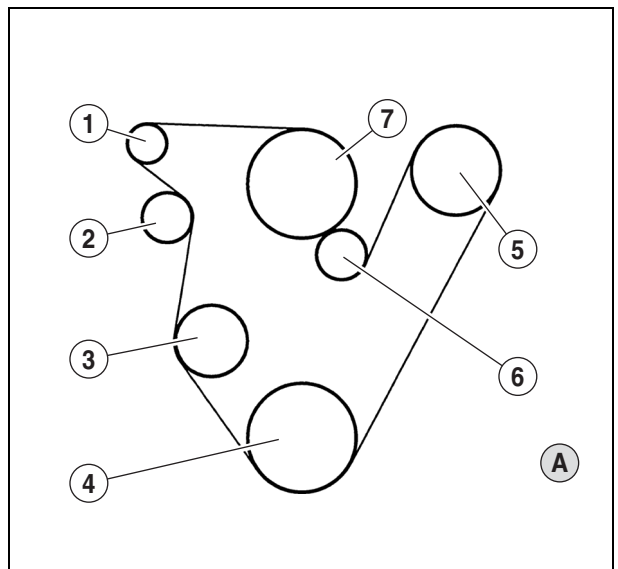

251hsn03

Fig. 169

Parts list (Fig. 169 and 170)

A With air conditioning, without air compressor.

B With air conditioning and air compressor.

1 Alternator.

2 Tensioner roller.

3 Water pump.

4 Crankshaft.

5 Refrigeration or air compressor.

6 Return roller.

7 Fan pulley.

8 Air compressor.

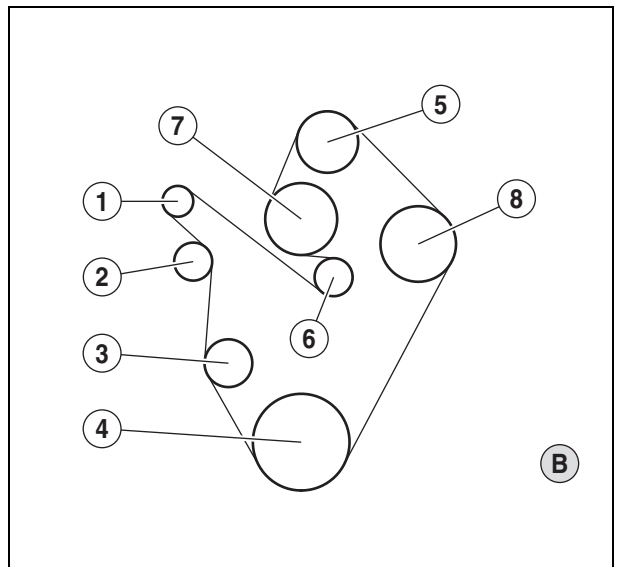

251hsn04

Fig. 170



TOOLS

Engine tools

REMOVING THE SHAFT	B1.63
REFITTING THE SHAFT	B1.63
ADJUSTING THE SHAFT	B1.64

COUNTERSHAFT

GENERAL.....	B1.65
EXPLODED VIEW (STAGE 6 PAGE B1.10)	B1.65
REMOVING THE SHAFT	B1.66
ADJUSTING THE SHAFT	B1.67
REFITTING THE SHAFT	B1.67
ADJUSTING THE BEARINGS.....	B1.68

CRAWLER SPEEDS

GENERAL.....	B1.69
EXPLODED VIEW	B1.70
REMOVING/REFITTING THE HOUSING	B1.72
REMOVING, ADJUSTING AND REFITTING THE CONTROL SYSTEM.....	B1.73
SETTING THE CONTROLS	B1.74

B2 – GTA 1040 AND GPA 30 LOW-PRESSURE HYDRAULIC CIRCUIT

LS 100 L/MIN LOW-PRESSURE CIRCUIT ON GTA 1040

CIRCUIT LAYOUT ON BEAM	B2.2
HYDRAULIC SYSTEM	B2.3
GEARBOX AND REAR AXLE LUBRICATION	B2.5
AXLE TUBE LUBRICATION.....	B2.6

LS 110 L/MIN LOW-PRESSURE CIRCUIT ON GTA 1040

CIRCUIT LAYOUT ON BEAM	B2.7
HYDRAULIC SYSTEM	B2.8
GEARBOX AND REAR AXLE LUBRICATION	B2.10
AXLE TUBE LUBRICATION.....	B2.11

LS 110 L/MIN LOW-PRESSURE CIRCUIT ON GPA 30

CIRCUIT LAYOUT ON BEAM	B2.12
HYDRAULIC SYSTEM	B2.13
REAR AXLE LUBRICATION	B2.15
AXLE TUBE LUBRICATION.....	B2.16

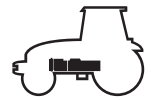

General specifications

GBA 10 removal/refitting procedure

Stage 1: Front clutch

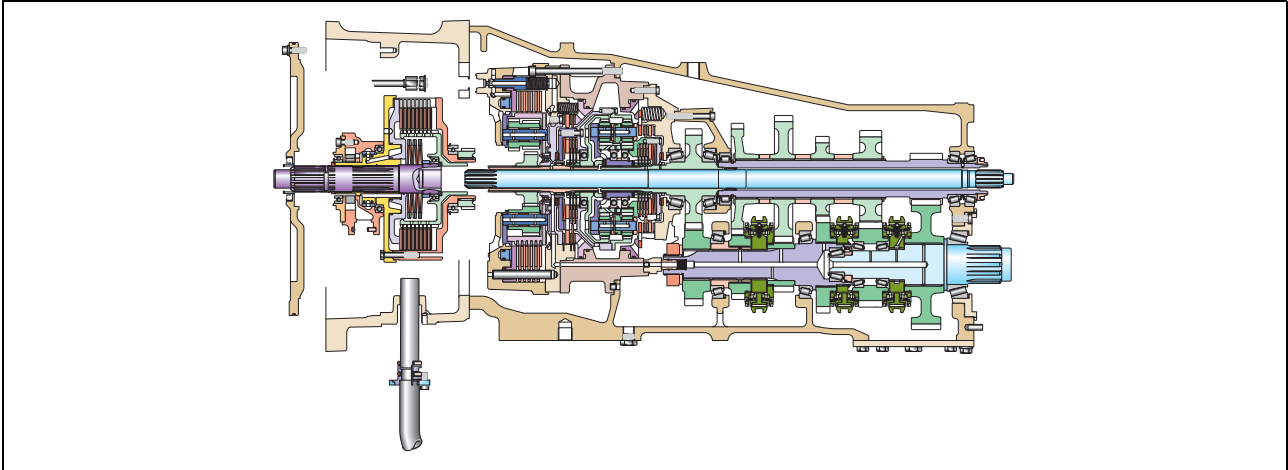

322hsm09

Fig. 7

Stage 2: Rear clutch

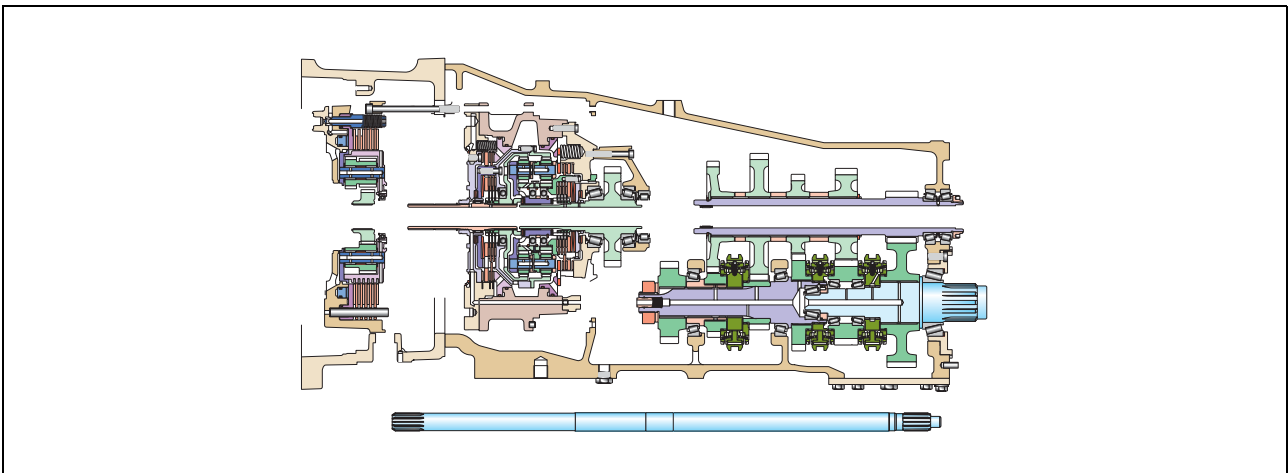

322hsm10

Fig. 8

Stage 3: Quadrishift unit

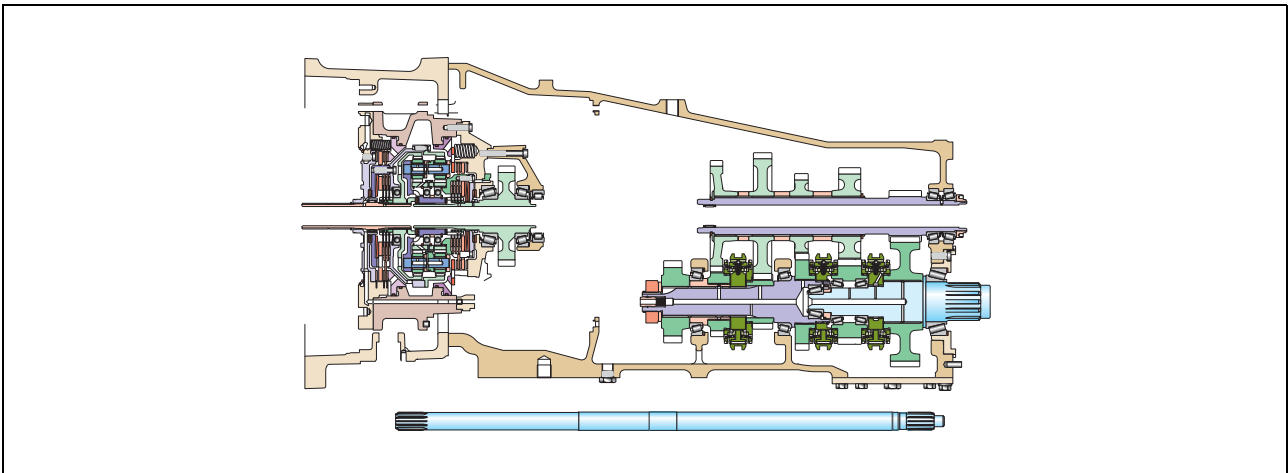

322hsm08

Fig. 9

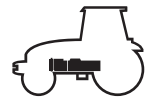

Front clutch

Refitting

Clutch

- Refit the assembly in reverse order to removal, making sure that the parts are the right way round.
- Refit the bearings using a press and an appropriate jig.
- Lubricate the new seals before fitting.
- Refit the piston (13), aligning it with the cover (10) by means of a pin of appropriate diameter in the indexed holes (A). Tap gradually and alternately around the edge with a mallet. Check that there are no fragments of seal after assembling.
- Fit the bearing (16) using an appropriate jig, with the sealed side against the shoulder of the shaft.
- Assemble the shaft (28), retainers, spacer (32), Belleville washers and cover (10) with the locally made tool.
- Assemble the body (18) and cover (10), inserting the backplates and discs (first backplate against the piston).
- Check the rotation of the hub (17) by hand.

Important: New discs must be soaked in a bath of transmission fluid for approximately one hour.

Pump

- Refit the rings (9) with miscible grease.
- Check that the pin (38) is fitted (hydraulic calibration).
- Refit the bush (7) inside the pump body (6), positioning the chamfer so as to ensure easier fitting on the rings.
- Check that the hydraulic ports are not blocked by the product and lubricate the bush.
- Refit the 1,5 bar valve.
- Oil and reassemble the pump on the cover (10), positioning the flat sections of the rotor appropriately.

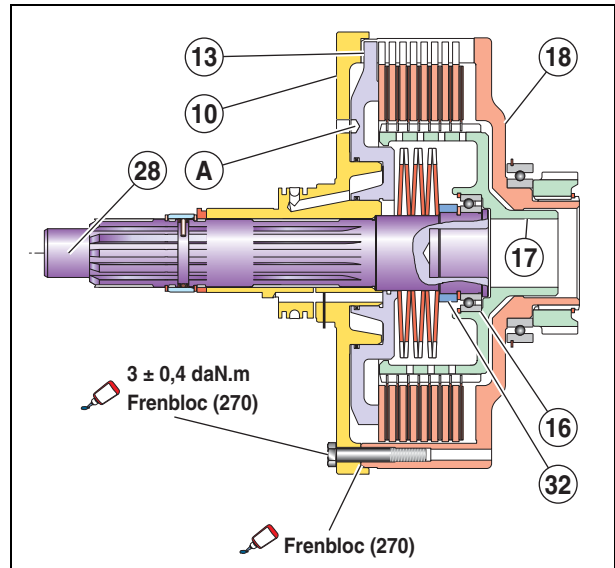

322hsm30

Fig. 27

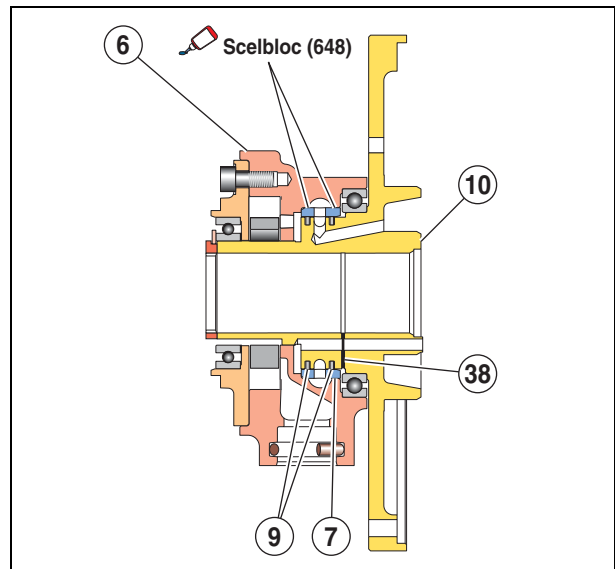

322hsm29

Fig. 29

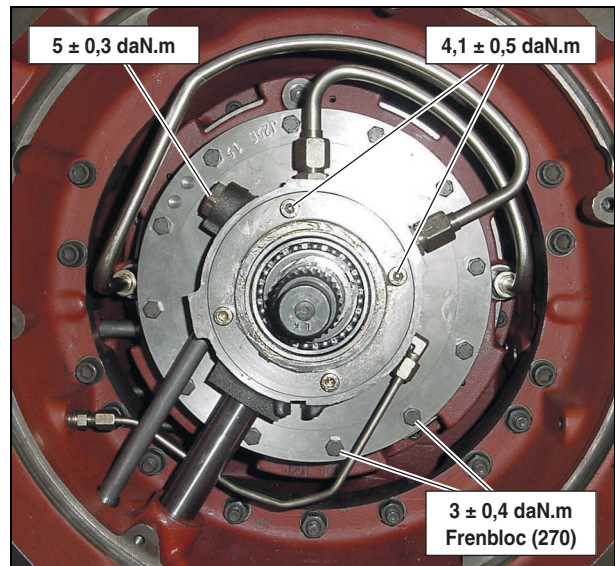

322hsm31

Fig. 29

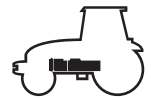

Quadrishift unit

Parts list

- | | | |
|---|-------------------------------|--|
| 1 Greasing ring. | 23 Screw. | 46 Spacer. |
| 2 Screw. | 24 Spring washer. | 47 Secondary planet carrier. |
| 3 Front cover. | 25 Ball bearing. | 48 Secondary sun gear. |
| 4 Spring. | 26 Primary ring gear. | 49 Retaining ring. |
| 5 Bearing. | 27 Primary shaft. | 50 Shims. |
| 6 Screw. | 28 Retaining ring. | 51 Rear clutch splined hub. |
| 7 Needle bearing. | 29 Thrust bearing. | 52 Rear brake thrust plate. |
| 8 Washer. | 30 Secondary ring gear. | 53 Rear clutch housing. |
| 9 Friction washer. | 31 Retaining ring. | 54 Rear clutch disc. |
| 10 Front clutch housing. | 32 Screw. | 55 Rear clutch backplate. |
| 11 Front brake disc. | 33 Rear brake piston. | 56 Rear brake disc. |
| 12 Front clutch Belleville washer. | 34 Tab washer. | 57 Rear brake backplate. |
| 13 Front clutch and brake thrust plate. | 35 Shims. | 58 Rear clutch and brake thrust plate. |
| 14 Front clutch disc. | 36 Primary ring gear carrier. | 59 Belleville washers. |
| 15 Front clutch backplate. | 37 Planet gear pin. | 60 Cover. |
| 16 Front clutch splined hub. | 38 Washer. | 61 Screw. |
| 17 Front brake backplate. | 39 Needle bearing. | 62 Friction washer. |
| 18 Front brake piston. | 40 Planet gear. | 63 Washer. |
| 19 O-ring. | 41 Deflector. | 64 Spring. |
| 20 Centre housing. | 42 Primary sun gear. | 65 Rear cover. |
| 21 Guide pin. | 43 Needle. | 66 Screw. |
| 22 Secondary ring gear carrier. | 44 Retaining ring. | 67 Secondary shaft. |
| | 45 Bearing. | |

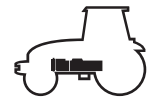

Quadrishift unit

Refitting the Quadrishift unit

- Check that the centring pin and the oil restrictor are present on the cover (65).
- Check that the thrust bearing (29) is present.
- Refit the cover (65) on the centre housing (20), aligning the marks made on removal.
- Rotate the shaft to engage the planet gears in the ring gears.
- Tighten the screws (66), coated with Frenetanch (242), to $3,3 \pm 0,4$ daN.m.
- Check shaft rotation.
- Refit the greasing ring (1), lightly coated with Scelbloc (648), taking care not to block the lubrication holes.
- Refit the parts according to the component refitting methods covered in this chapter.
 - Refit the Quadrishift unit.
 - Refit the rear clutch.
 - Refit the front clutch.
 - Refit the pump.
 - Couple up the tractor.

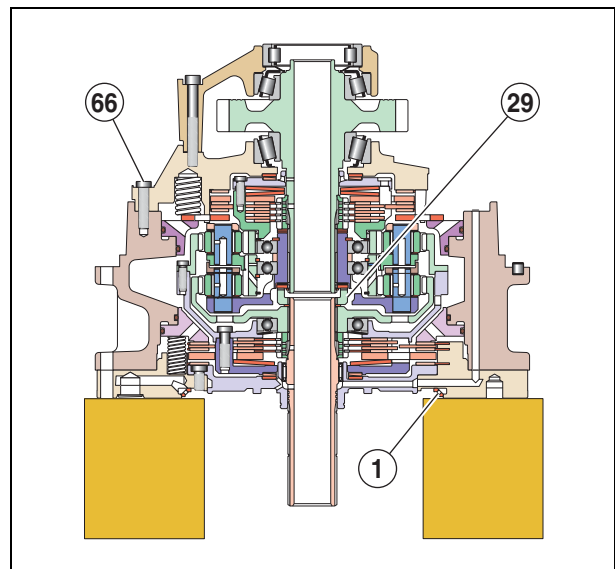
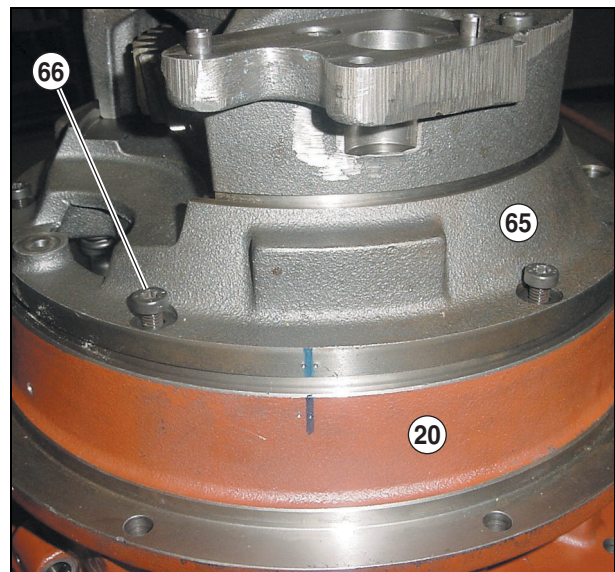

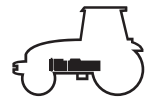

Output shaft

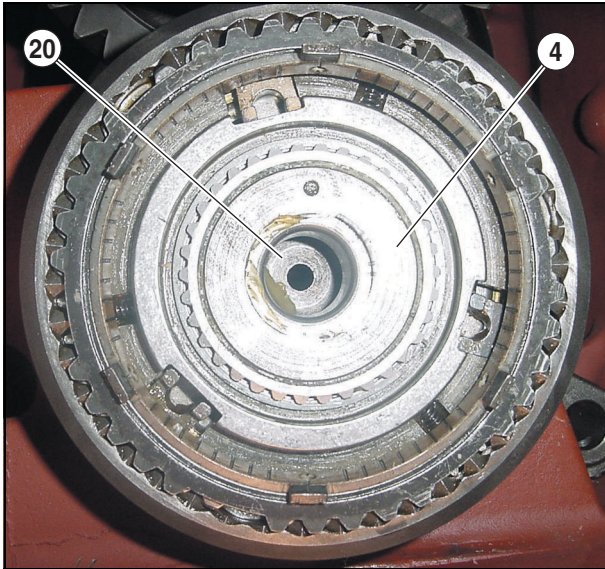

322hsm1e

Fig. 106

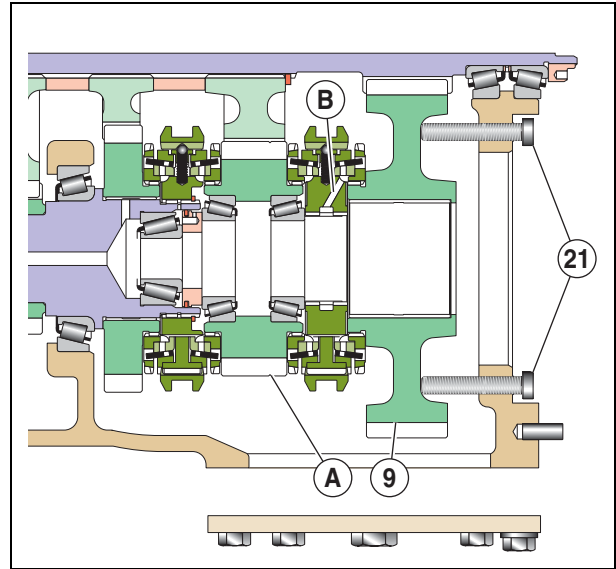

322hsm1f

Fig. 107

Refitting the shaft

- Replace the faulty parts.
- Fit the bearings using appropriate jigs.
- Refit the assembly in reverse order to removal while observing the following instructions:
- Fit the bush (4), with its sealing ring lightly smeared with grease, into the input shaft (20).
- Position the bush (4) such that the flat section is facing upwards.
- Smear the synchroniser bushes and cones lightly with grease.
- Fit the pinion assembly and secure it with 2 screws (21) flush with pinion (9).
- If the gearbox has been removed, position it vertically and secure pinion (9) with 2 overturned threaded rods (22) (Fig. 108), then fit the rest of the pinions.

Important: Position the pinion locator (A) and the synchroniser lubrication duct (B) to the rear of the gearbox.

- Engage the shaft, positioning the flat section uppermost (aligned with the previously fitted bush (4)).
- Refit the assembly in reverse order to removal, observing the instructions mentioned in the parts concerned.

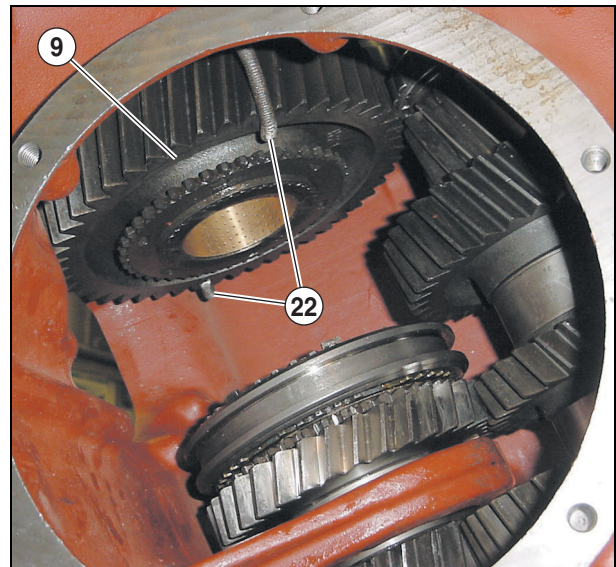

322hsm1g

Fig. 108

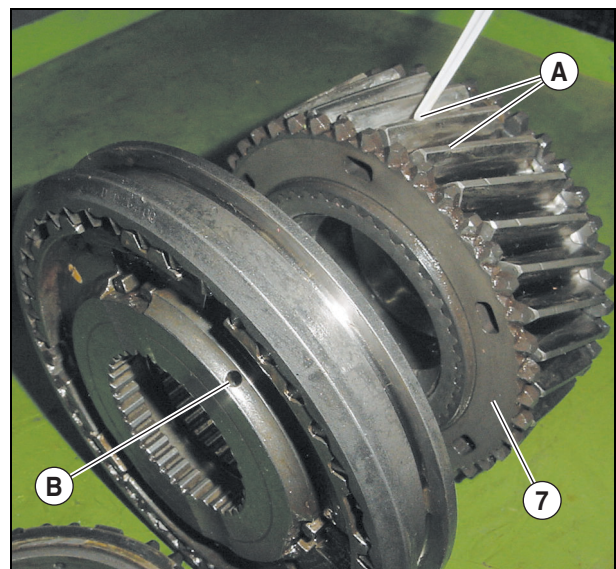

322hsm1h

Fig. 109

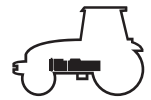

Crawler speeds

General

It is made up of a step-down gear and a dog control function. The step-down gear is made up of an epicyclic gear set comprising a planet carrier and ring gear assembly housed at the rear of the gearbox. The control

is mounted on the rear axle and activates the engagement dog of the step-down gear via the fork. The dog can only be engaged at a standstill. The reduction ratio of the step-down gear is 0,25.

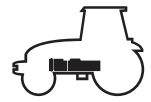

LS 110 l/min low-pressure circuit on GTA 1040

Circuit layout on beam

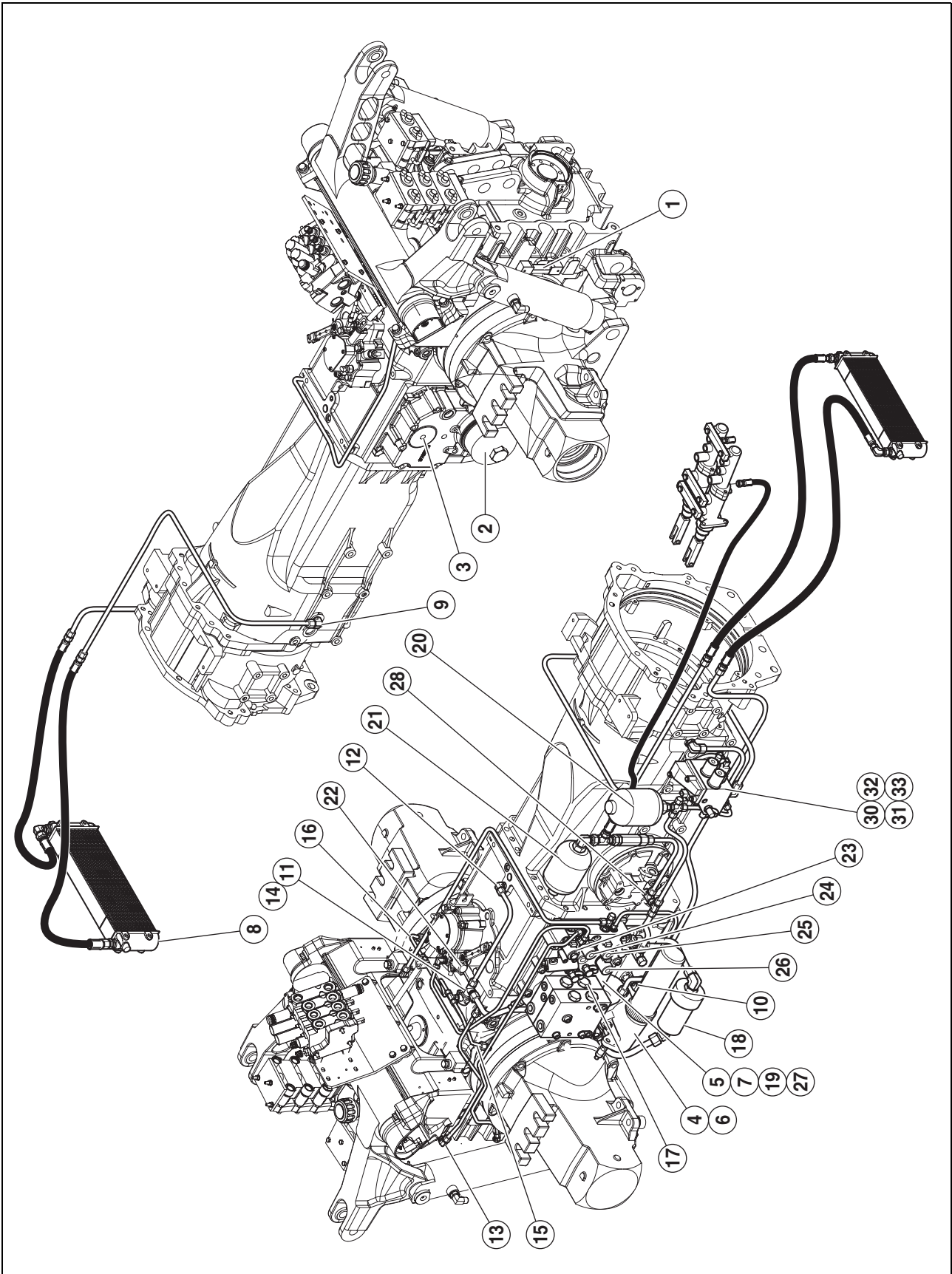

391hsm35

Fig. 5



Low-pressure hydraulic components

Revershift and Quadrishift control

General

The system control assembly consists of the following 3 main parts:

The distribution unit (4) (hydraulic unit) mounted on the right-hand side of the transmission. It consists of 2 distinct parts which control the Revershift and Quadrishift clutch assembly.

The accumulator, mounted on the supply tube connected to the hydraulic unit, can be used to step up the oil flow to fill the clutch piston chambers when necessary. As a result, the pistons react more quickly.

Parts list (Fig. 17, 18 and 19)

- | | |
|--|---|
| <ul style="list-style-type: none">1 Low-pressure filter, 60 μ.2 Field/road range solenoid valve.3 Accumulator.4 Distribution unit.5 Revershift reverse gear clutch supply.6 Revershift forward gear clutch supply.7 Quadrishift rear brake piston supply.8 Quadrishift front brake piston supply.9 Revershift forward gear clutch proportional solenoid valve.9' Revershift forward gear clutch pressure coupling. | <ul style="list-style-type: none">10 Revershift reverse gear clutch proportional solenoid valve.10' Revershift reverse gear clutch pressure coupling.11 Quadrishift front brake piston solenoid valve.11' Quadrishift front brake piston pressure coupling.12 Quadrishift rear brake piston solenoid valve.12' Quadrishift rear brake piston pressure coupling.13 Distribution unit supply, 17 bar.13' Supply pressure coupling, 17 bar. |
|--|---|

Accumulator

Make: HYDAC.

Capacity: 1 l.

Gas: Nitrogen.

Inflation pressure: 9 ± 1 bar.

Service pressure: 17 bar.

Maximum pressure: 30 bar.

N.B.: The accumulator maintains a pressure of 17 bar for a while after switching off the engine. If immediate action on the circuit is necessary, proceed with caution.



"Hydraulic inspection results" sheet

This sheet is intended to be duplicated and completed for each operation on the tractor. If it is to be sent to CLAAS after-sales department, it is essential to complete:

Tractor type:

Serial n°:

Total operating hours:

Date of operation:

Independent lubrication check

Test conditions Oil temperature at 60°C	Engine running at 1 000 rpm		Engine running at 2 000 rpm	
	Pressure in bar	Measured value	Pressure in bar	Measured value
Forward or reverse gear engaged	0,25 to 0,4		0,7 to 1,2	
Forward or reverse gear in neutral	1,5 to 2		2 to 3	



General

Clutch solenoid valves and pressure take-up points

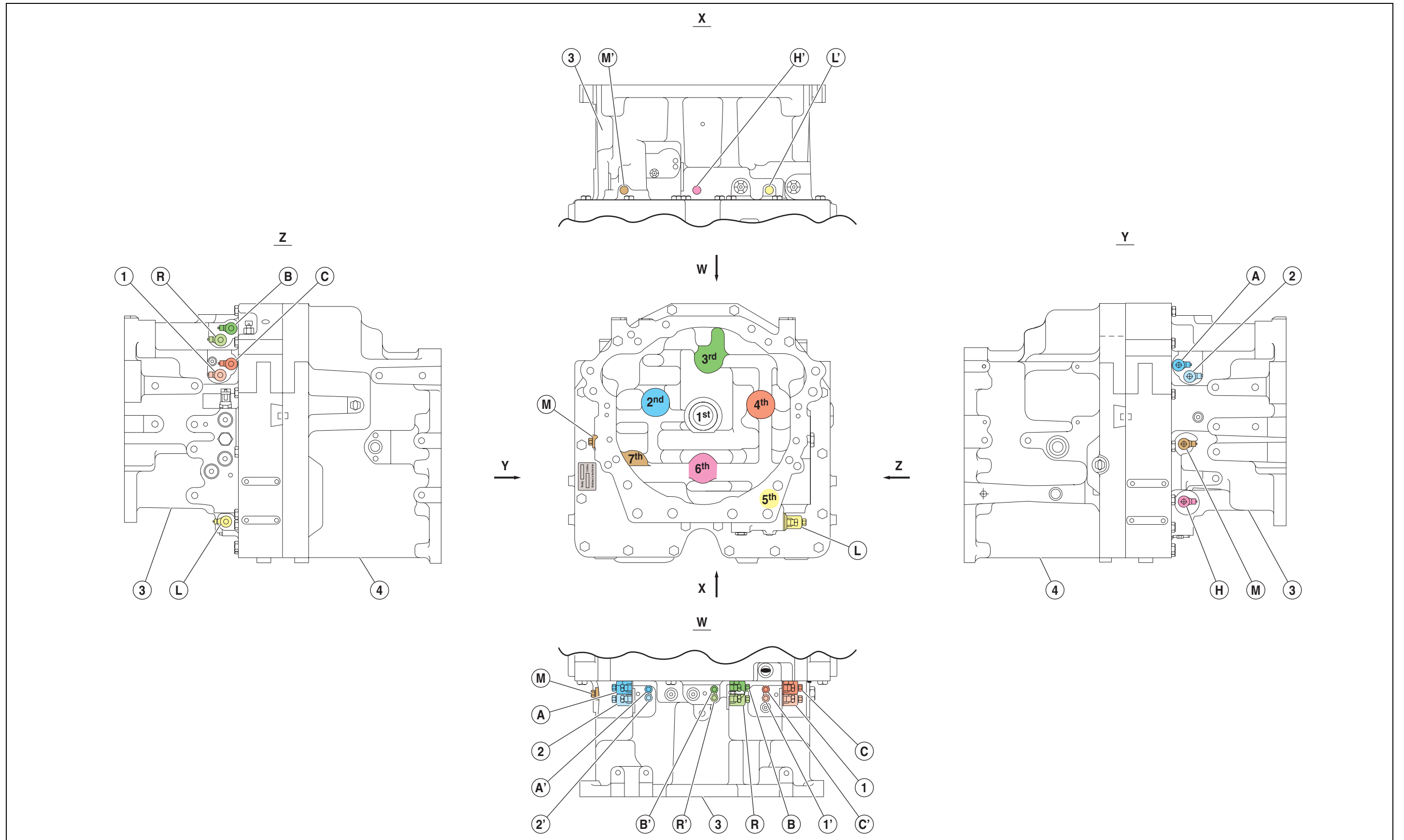



B4
FULL POWERSHIFT LOW PRESSURE
HYDRAULIC CIRCUIT

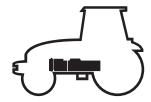

Measurement and checking points

Test conditions:

- Engine at nominal speed.
- Oil temperature at 80°C.

Lubrication pressure check

Discharge valve operation

- Fit pressure coupling n° 60 05 005 911 in place of the plug (17), connect quick-release coupling n° 60 05 005 731, the adapter (¼ - 18 NPTF - BSPP ¼), hose n° 60 05 005 703 and 0 to 2 bar tester n° 60 05 005 521.
- The pressure must be $1,8 \pm 0,2$ bar (at 1 000 rpm, it must be $0,6 \pm 0,2$ bar).

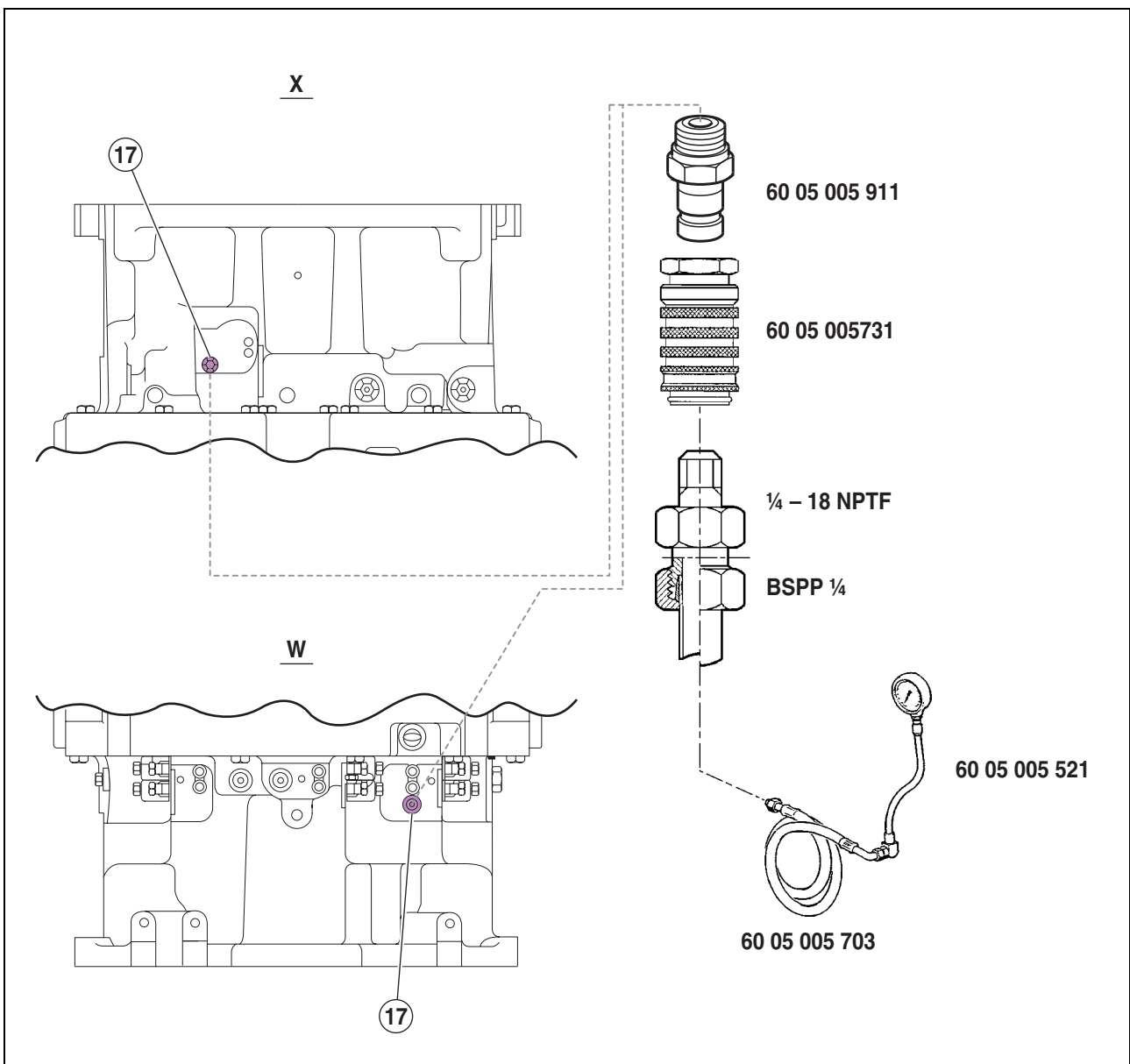

324hsm30

Fig. 21

CONTENTS

C1 – GPA 40 REAR AXLE

TIGHTENING TORQUES AND MAIN ADJUSTMENTS

GEARBOX/REAR AXLE COUPLING	C1.3
REAR AXLE/PTO HOUSING COUPLING.....	C1.4
GENERAL CROSS-SECTION.....	C1.5
5" DIFFERENTIAL	C1.6
ND AXLE TUBES	C1.6
HD AND HD+ AXLE TUBES.....	C1.6
HDE AXLE TUBES	C1.6

GPA 40 DRIVE PINION

GENERAL.....	C1.7
REMOVAL/REFITTING	C1.8
SETTING AND ADJUSTING THE PROTRUSION DISTANCE OF THE DRIVE PINION	C1.11

5" DIFFERENTIAL

GENERAL.....	C1.14
REMOVING/REFITTING THE BEARINGS	C1.16
REMOVING/REFITTING THE DIFFERENTIAL CASE.....	C1.18
REMOVING/REFITTING THE DIFFERENTIAL LOCK.....	C1.20
REMOVING/REFITTING THE PLANET GEARS, SUN GEARS AND RING GEAR	C1.21
ADJUSTING THE BACKLASH	C1.22
SHIMMING THE DIFFERENTIAL CASE ROLLER BEARINGS	C1.23

ND AXLE TUBES

GENERAL.....	C1.26
REMOVAL	C1.28
REFITTING.....	C1.29
REMOVING THE PLANET CARRIER.....	C1.31
REFITTING THE PLANET CARRIER	C1.31
REMOVING THE ROLLER BEARINGS AND SEALS.....	C1.32
REFITTING THE ROLLER BEARINGS AND SEALS	C1.32
SHIMMING THE WHEEL SHAFT BEARINGS	C1.33
REPLACING THE WHEEL STUD	C1.33

HD AND HD+ AXLE TUBES

GENERAL.....	C1.34
REMOVAL	C1.36

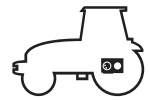

GPA 40 drive pinion

Removal/refitting

Uncouple the tractor between the gearbox and rear axle as follows:

- Refer to Chapter "H" for partial cab removal. Operations 1 to 7.
- Drain the transmission system.
- Remove the reservoir(s) and disconnect the pipes, hoses and wiring harnesses interfering with the uncoupling operation.
- Make the tractor safe with stands and trolleys.
- Chock the tilt between the front axle and the cradle.
- Release the transmission lock.
- Remove the RH and LH hydraulic covers.
- Remove the PTO clutch (15) (see paragraph concerned).
- Remove the four-wheel drive shaft and clutch (16) (see chapter "D").
- Remove the crawler speed system if fitted (see chapter "B").
- Remove the retaining ring (17), washer and shims.
- Remove the driving gear (18) from the 4WD casing.
- Remove the pivot screw (19) from the handbrake compensator.
- Free and secure the nut (14) with spanner n° 60 05 006 310. Fit special socket n° 60 05 006 311 at the end of the drive pinion (Fig. 10) and turn clockwise.
- Only release the nut.
- Remove the eight screws (9) and two screws (6).

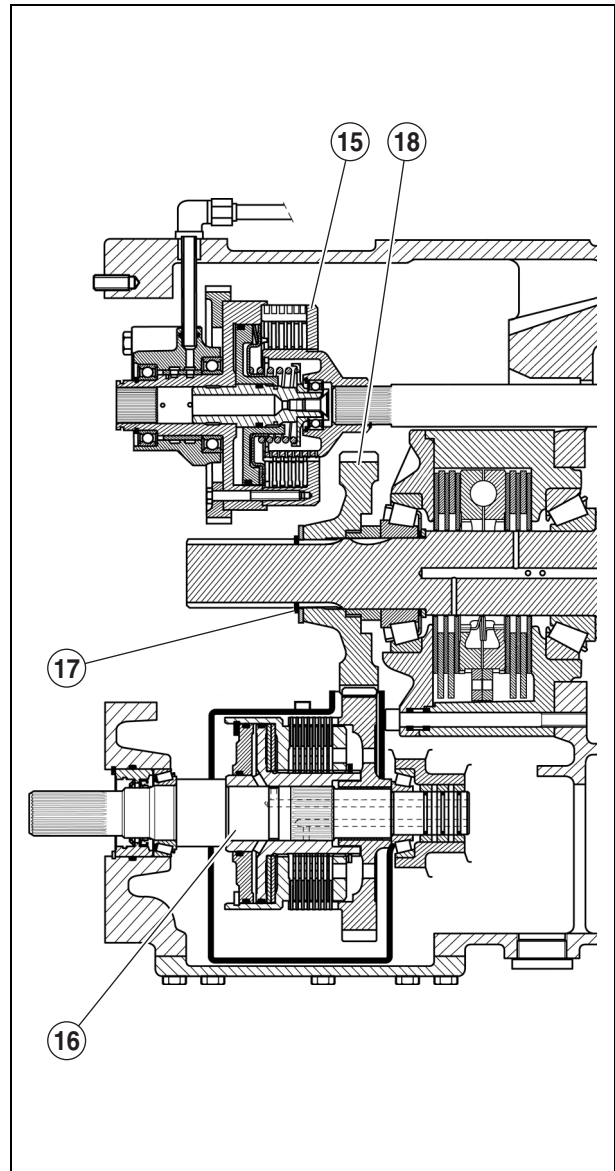

341hsm27

Fig. 9

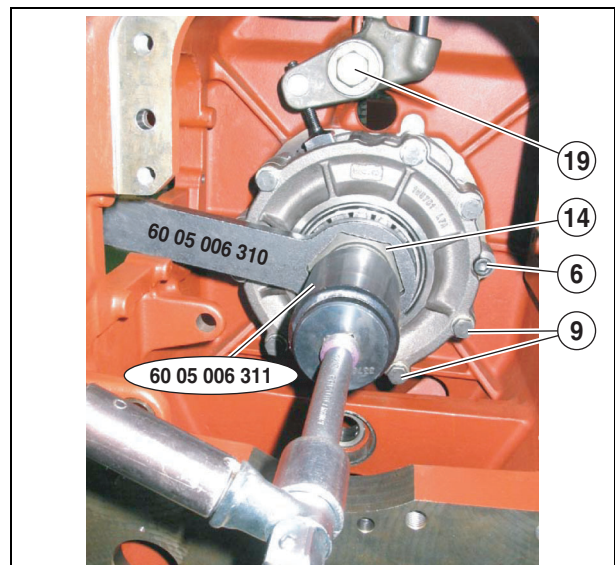

341hsm28

Fig. 10

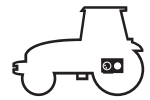

5" differential

Removing/refitting the differential lock

- Remove the differential case as described in the procedure above.
- Position the differential case with the cover (29) facing up.
- Remove the screws (20).
- Remove the cover (29), discs (23), backplates (24) and hub (25).
- Remove the screws (22) and case (21).
- Tap the cover (29) lightly on a wooden block to remove the piston (27).
- Replace the O-rings. Drive out the cup (30) if necessary.

N.B.: If the case (21), cover (29) and bearing (36) need to be replaced, the differential case must be shimmed and the backlash between the drive pinion and the ring gear checked (see following pages).

- Check that the hydraulic duct in the cover is not blocked.
- Lubricate the new seals before fitting.
- Refit the piston (27) by tapping gradually and alternately around the edge with a mallet.
- Check that there are no seal fragments after fitting.
- Coat the screws (22) lightly with Frenbloc (270) and tighten to $11,5 \pm 1,5$ daN.m. .
- Fit the hub, backplates and discs.
- Position the assembled cover (29) of the piston (27).
- Fit and tighten the screws (20) coated with Frenbloc (270) to 11 ± 1 daN.m.
- Check manually that the discs and backplates are not stressed.
- Refit the differential case as described in the procedure above.

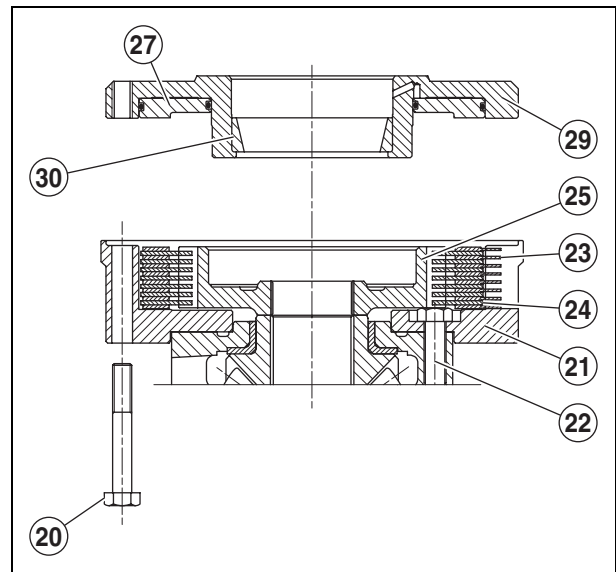

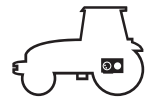

ND axle tubes

Removing the roller bearings and seals

- Remove the axle tube from the rear axle housing.
- Remove the planet carrier (19).
- Remove:
 - The tab washer (13).
 - The cone (5) on the planet carrier side (free on the shaft).
- Extract the shaft (1) from the axle tube.
- Extract the wheel-side cone (5).
- Drive out the 3-lip seal (3) and its housing (4).
- Use an extractor to remove the bearing cups.
- Push out the seal (10).

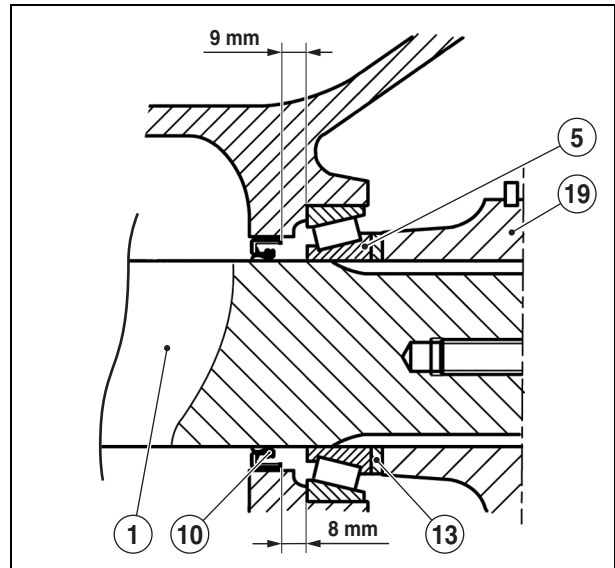

341hsm08

Fig. 55

Refitting the roller bearings and seals

- Clean the seal bearing faces. The seal bearing faces, the cups and cones should be free from burrs and impacts.
- Coat the outside diameter of the seal (10) with Loctite Frenetanch (542).

N.B.: Fit the seals the right way round.

Without replacing the shaft (1)

Important: To prevent the lip of the seal from bearing at the same point on the shaft, fit the seal 9 mm from the shoulder of the cup (Fig. 55).

When replacing the shaft (1)

- Position the seal 8 mm from the shoulder of the cup (Fig. 55).
- Lubricate and fit the bearing cups.
- Fit the seal housing (4) 1 mm from the face of the axle tube.
- Fit the 3-lip seal (3) with a suitable jig.
- Lubricate the shaft (1) and fit the wheel-side cone (5).
- Grease the cone and lips of the seal moderately.
- Protect the splines of the shaft (1) and insert it in the axle tube.
- Shim as described in the procedure below.
- Grease via the plug (7).
- Refit the axle tube.

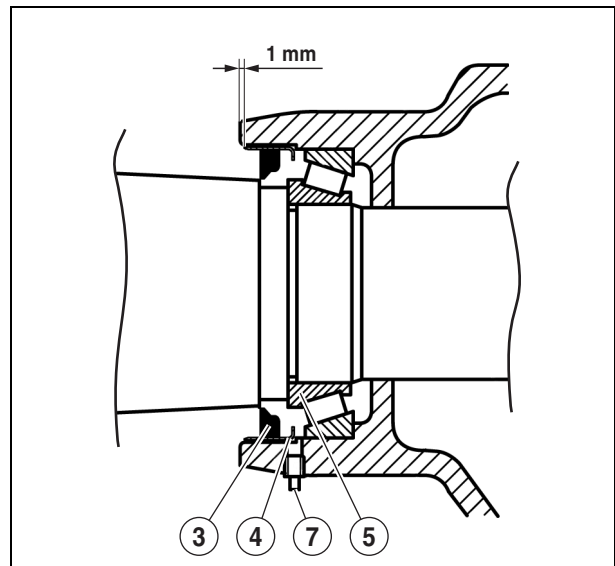

341hsm09

Fig. 56

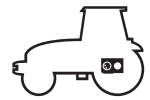

HDE axle tubes

Removal

- Immobilise the tractor. Apply the handbrake. Chock the tilt between the front axle and the cradle.
- Disconnect the battery.
- Using a trolley jack, lift the concerned side of the tractor and position a jack stand.
- Unscrew and remove the cab damper support on the axle tube side by lifting the cab slightly (Fig. 72).
- Make the cab safe.
- Remove the draft sensor and accessories.
- Position under the axle tube an appropriate support on a trolley jack or using a hoist.
- Separate the axle tube from the rear axle housing without removing screw (33) (Fig. 71).
- Remove:
 - The brake disc (28).
 - The circlip (27) and the splined pinion (26).
 - The backing plate (23) with its seals (24) and (25) by removing screw (33) ;
 - The sun gear (22).
- Remove the ring gear.

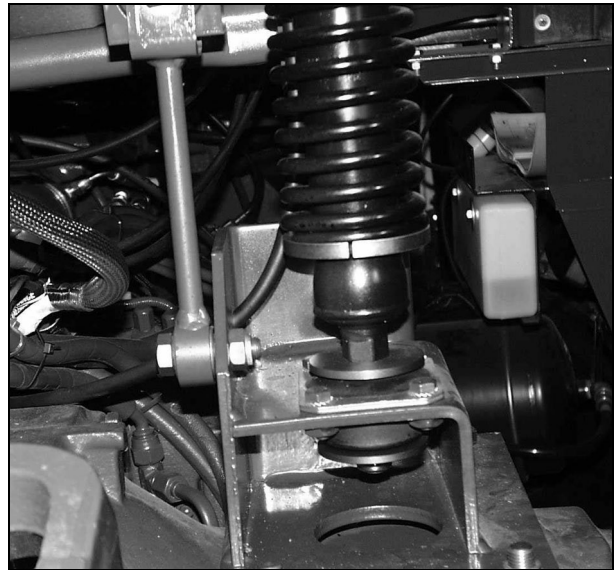

341hsm01

Fig. 72

N.B.: Remove the brake backing plate and the ring gear whenever the axle tube is uncoupled in order to renew the seals and avoid leaks.

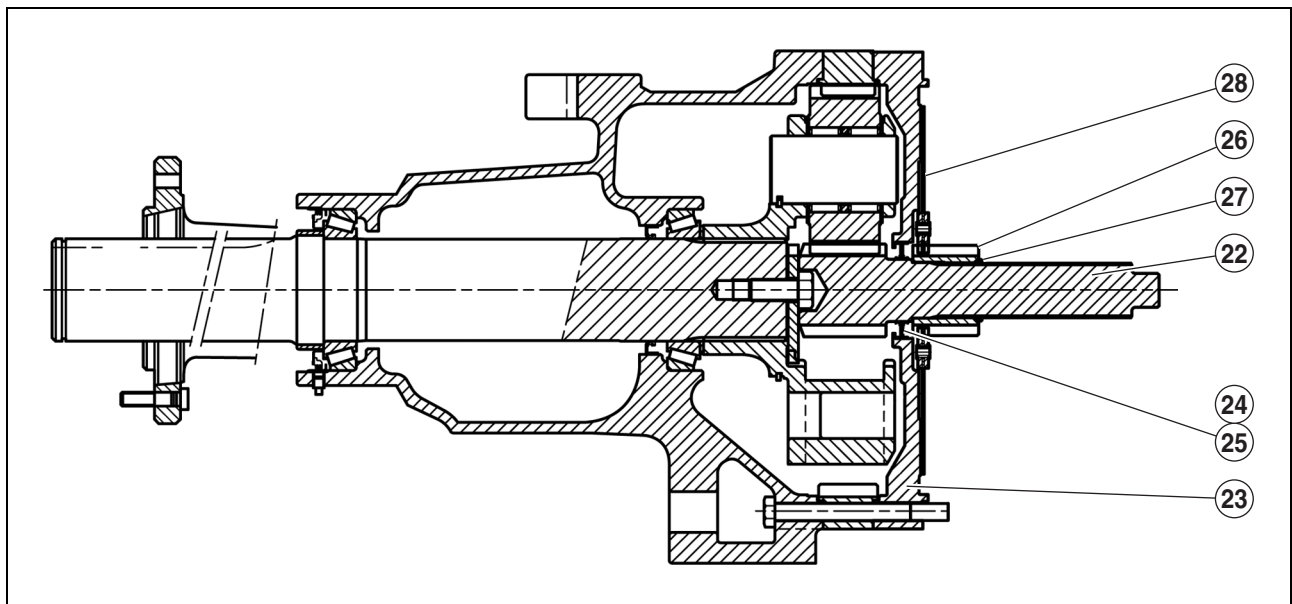

341hsm23

Fig. 73

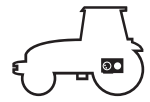

GPA 40 power take-off upper shaft

Exploded view of 540/1 000 rpm version

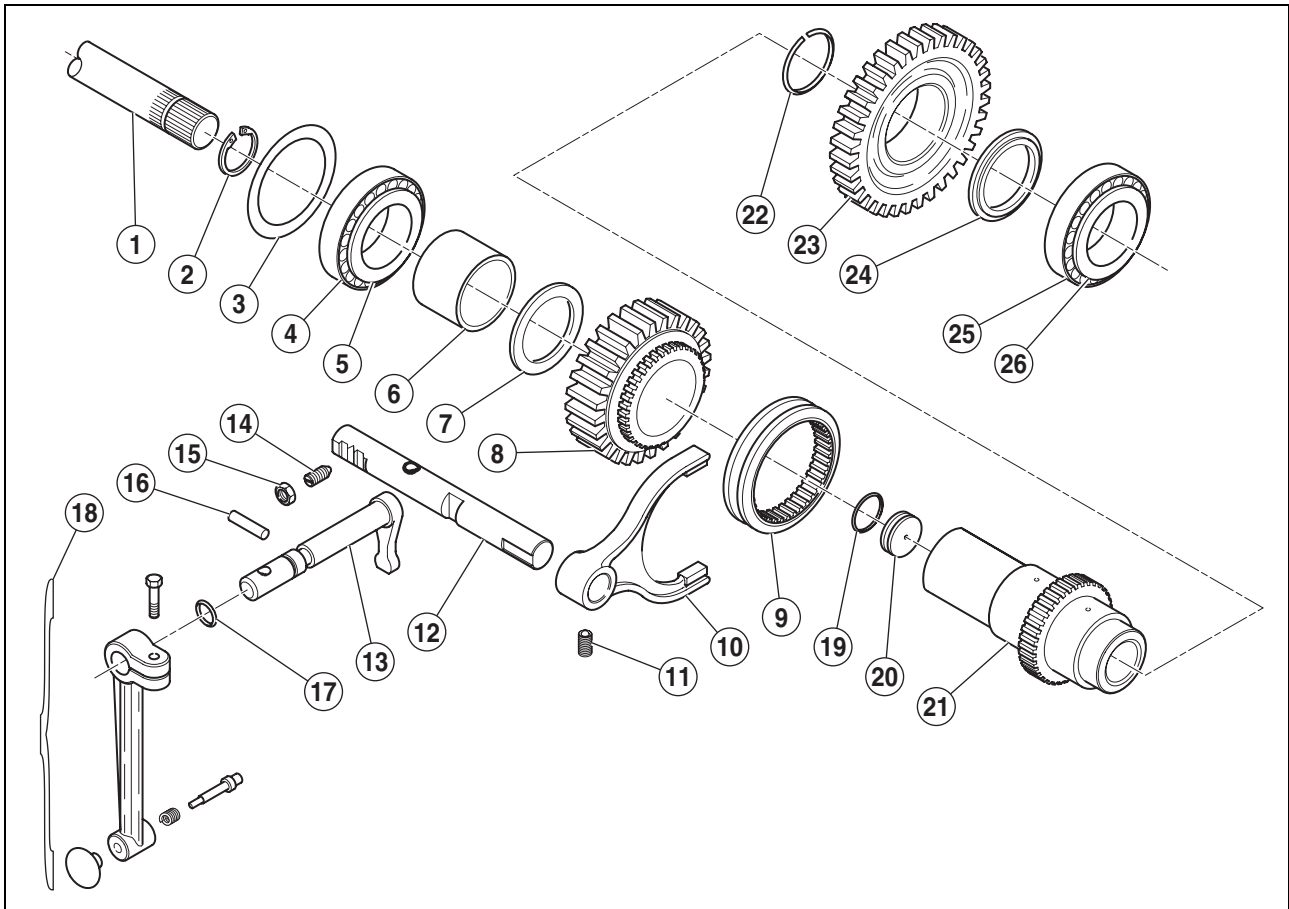

341thsm49

Fig. 94

Parts list

- | | | |
|-------------------------------|-------------------------------------|---|
| 1 Countershaft. | 13 Control shaft. | 25 Bearing cup. |
| 2 Retaining ring. | 14 Locking screw. | 26 Bearing cone. |
| 3 Shims. | 15 Locknut. | 27 750 rpm sliding gear hub. |
| 4 Bearing cup. | 16 Blocking pin. | 28 750 rpm sliding gear. |
| 5 Bearing cone. | 17 O-ring. | 29 750 rpm fork. |
| 6 Spacer (without 750 rpm). | 18 540/1 000 rpm control. | 30 750 rpm guide rod. |
| 7 Washer. | 19 O-ring. | 31 Prevention system. |
| 8 540 rpm drive gear. | 20 Bushing with calibrated orifice. | 32 750 rpm control. |
| 9 540/1 000 rpm sliding gear. | 21 Shaft (540/1 000 rpm version). | 33 750 rpm drive gear. |
| 10 540/1 000 rpm fork. | 22 Sealing ring. | 34 Shouldered bushing. |
| 11 Needle screw. | 23 1 000 rpm drive gear. | 35 O-ring. |
| 12 540/1 000 rpm guide rod. | 24 Deflector. | 36 Shaft (540/1 000 and 750 rpm version). |



GPA 40 power take-off lower shaft

Adjustment

- Shim with the cover only.
- Do not mount the upper shaft with the drive gears and guide rods.
- Assemble the upper shaft.
- Tighten nut (3) provisionally to 20 ± 4 daN.m.
- Fit shims (4) to the thickness measured on removal minus 0,15 mm.
- Lubricate the bearings.
- Fit the cover (2).
- Tighten screws (1) in opposition to 8 ± 1 daN.m.
- Check that the end of the interchangeable sleeve (17) is a smooth, flat surface.

Thickness "E2" of shims (4)

- Push the shaft firmly and turn it to seat the bearings.
- Place a dial gauge probe at the end of the sleeve.
- Pull hard on the shaft and rotate it to seat the bearings.
- Add to the shims positioned on measuring, shims of a thickness corresponding to the measured play plus the preload value $0,05 \pm 0,05$ mm.
- If possible, adjust towards the maximum end of the tolerance scale.

For example, if the measured play is 0,10 mm and the shim thickness is 1,50 mm:

"E2" (maximum) = $1,50 + 0,10 + 0,10 = 1,70$ mm

"E2" (minimum) = $1,50 + 0,10 + 0 = 1,60$ mm

According to the example, the thickness of the shims to be positioned should be as close to 1,70 mm as possible.

Refit the assembly, consulting the sections concerned.

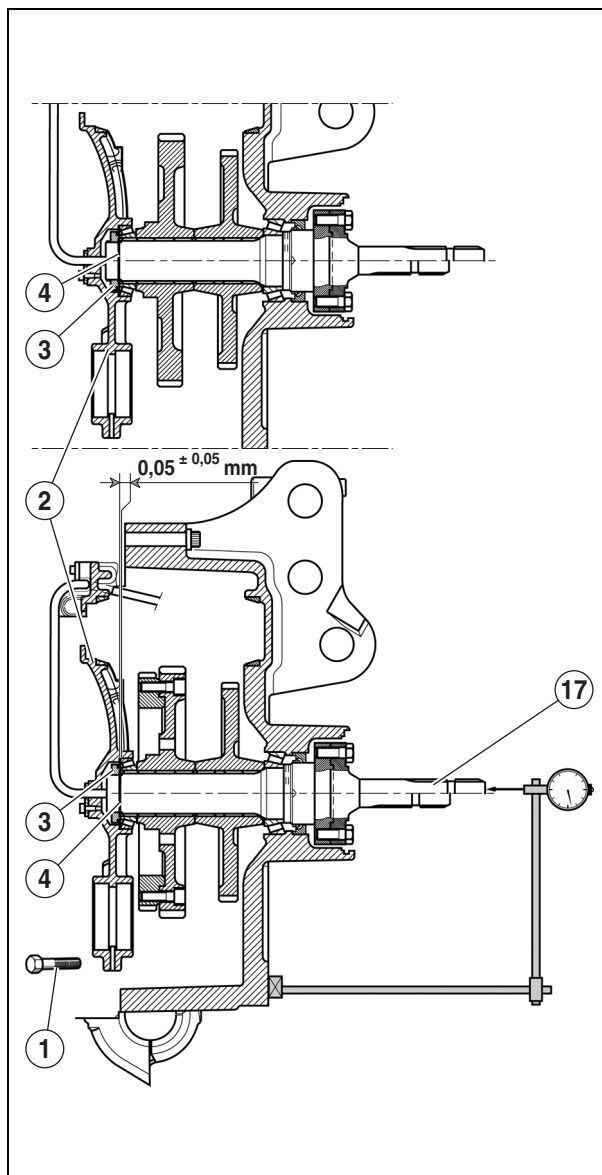

341hsm65

Fig. 111

Tightening torques and main adjustments

5" differential

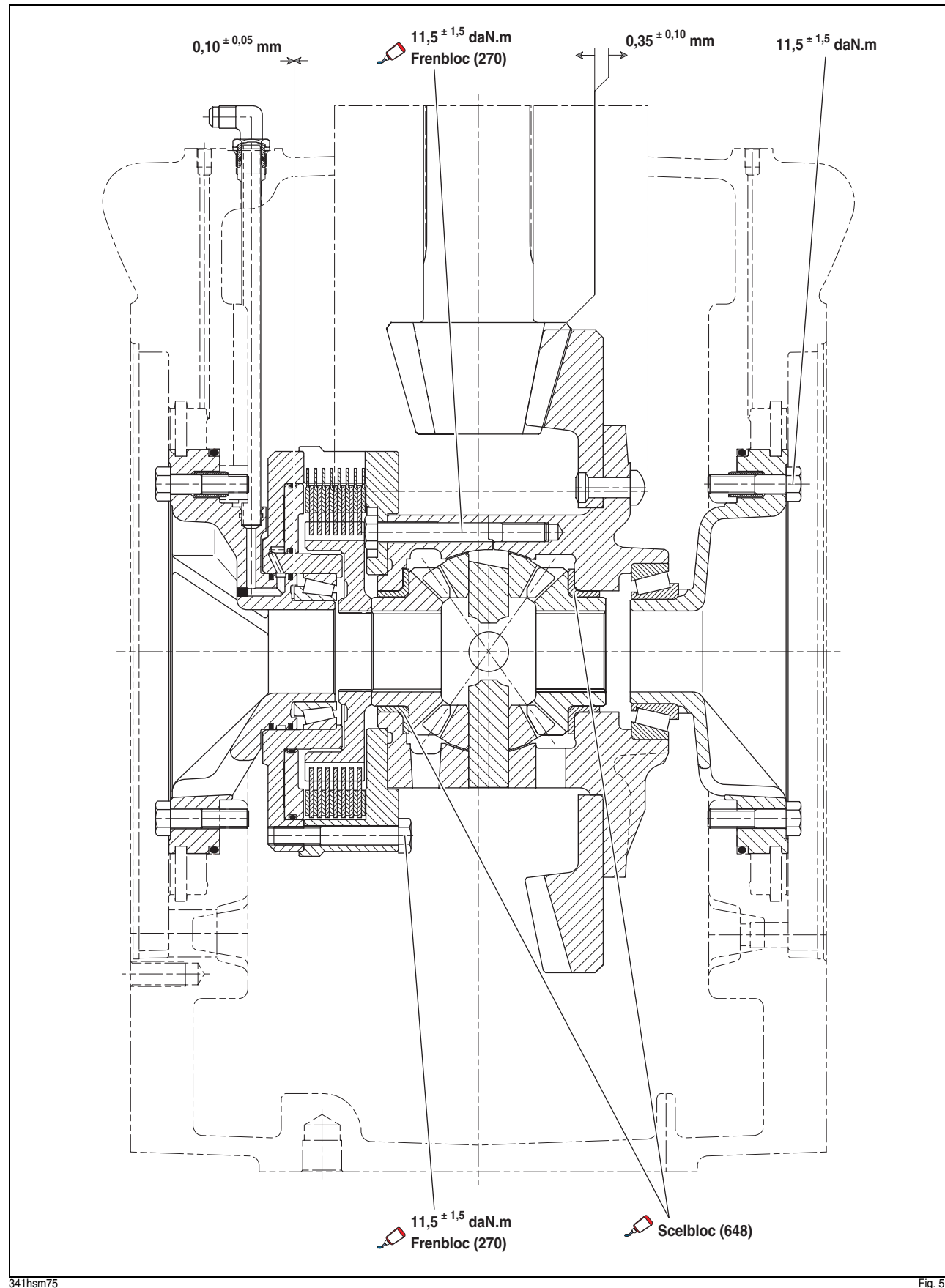

341hsm75

Fig. 5

HD+ axle tubes

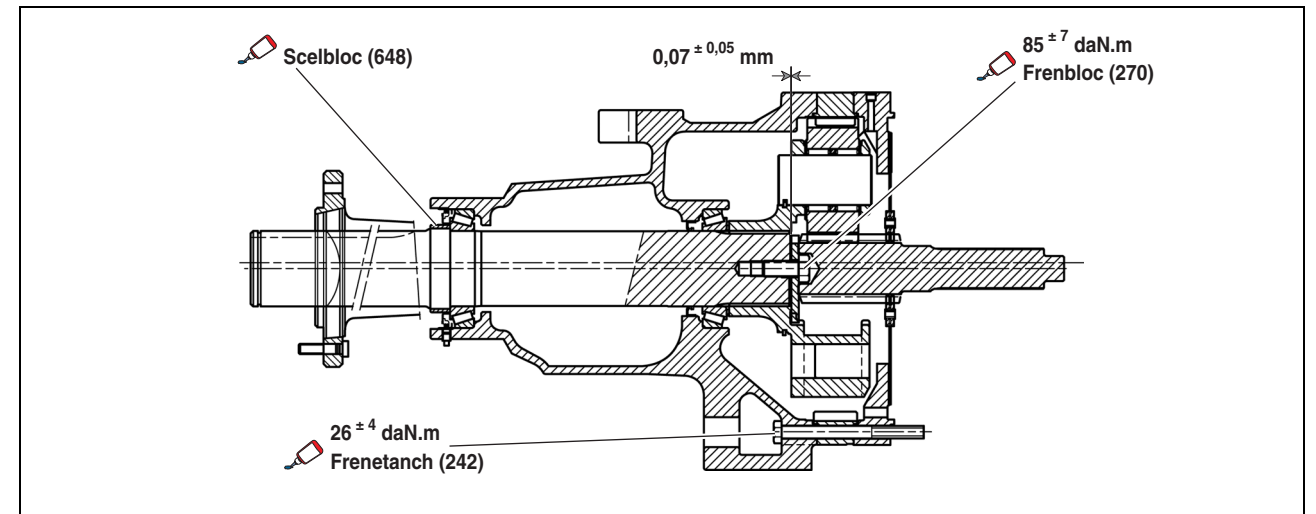

341hsm77

Fig. 6

HDE axle tubes

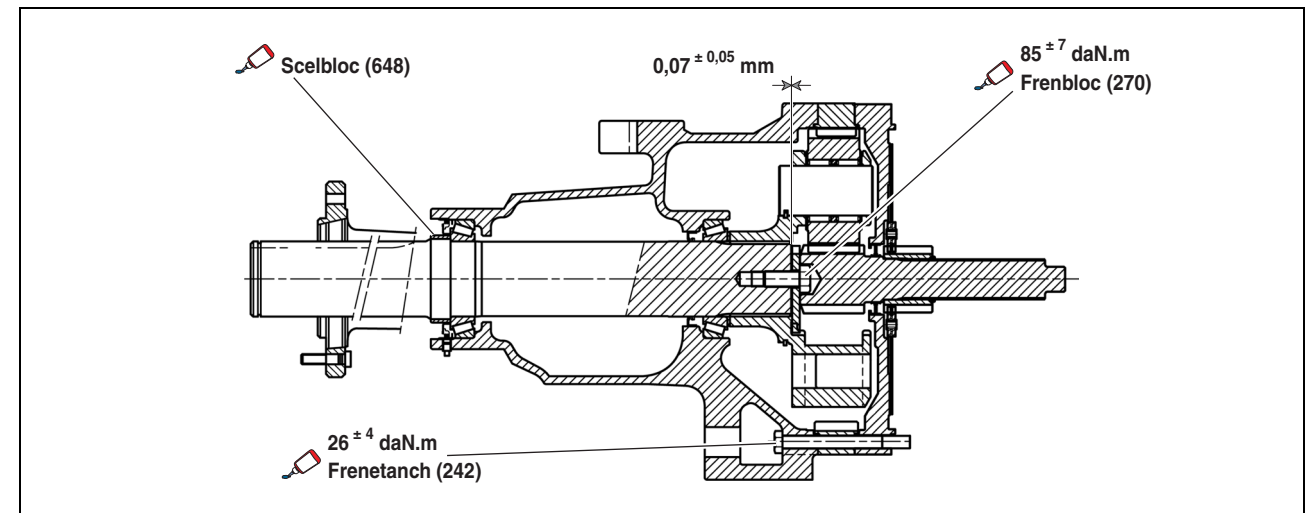

341hsm78

Fig. 7

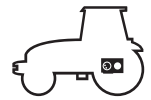

5" differential

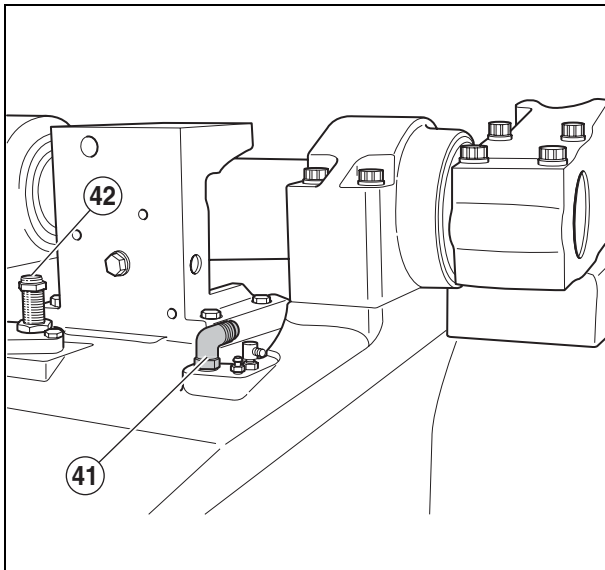

342hsm29

Fig. 22

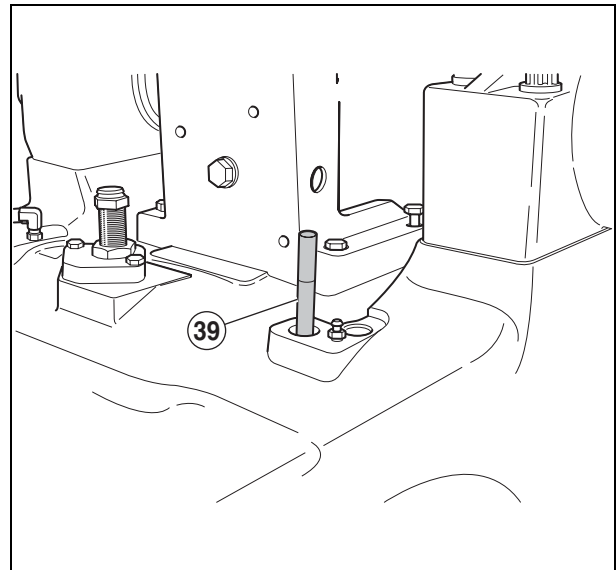

342hsm30

Fig. 23

Removing/refitting the bearings

LH bearing

N.B.: The bearing (36) and sealing rings (34) of the differential lock can be worked on by removing just the left-hand axle tube.

- Remove the left-hand axle tube (see paragraph concerned).
- Unscrew the coupling (41) and remove the transfer tube (39).
- Remove the brake piston (see chapter "C3").
- Remove the forward motion sensor (42) from the housing.
- Remove the screws (37) from the bearing (36), fit two diametrically opposite locating studs "A" into the housing and tighten them firmly up against the differential locking cover (29) (Fig. 25).
- Extract the bearing with the aid of the tapped holes and two screws (B) and recover the cone 25 and shims (31).

N.B.: The locating studs (A) hold and centre the differential assembly in the housing. Do not loosen the studs or the assembly may become skewed and section the sealing rings (34) on refitting the bearing.

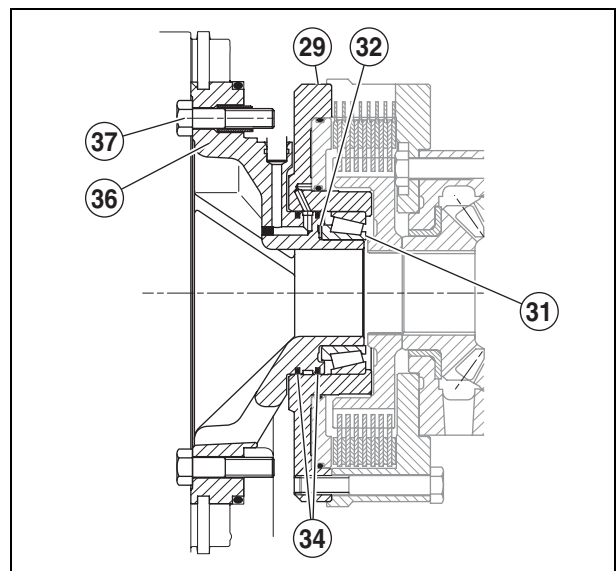

342hsm31

Fig. 24

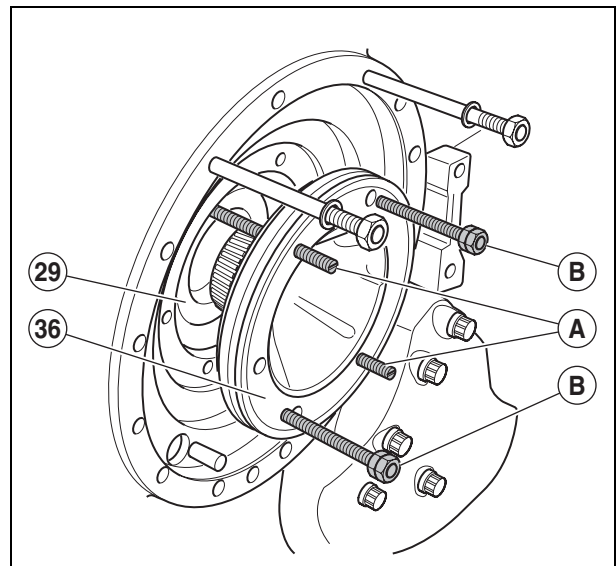

342hsm32

Fig. 25

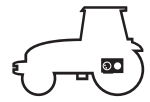

GPA 30 power take-off clutch

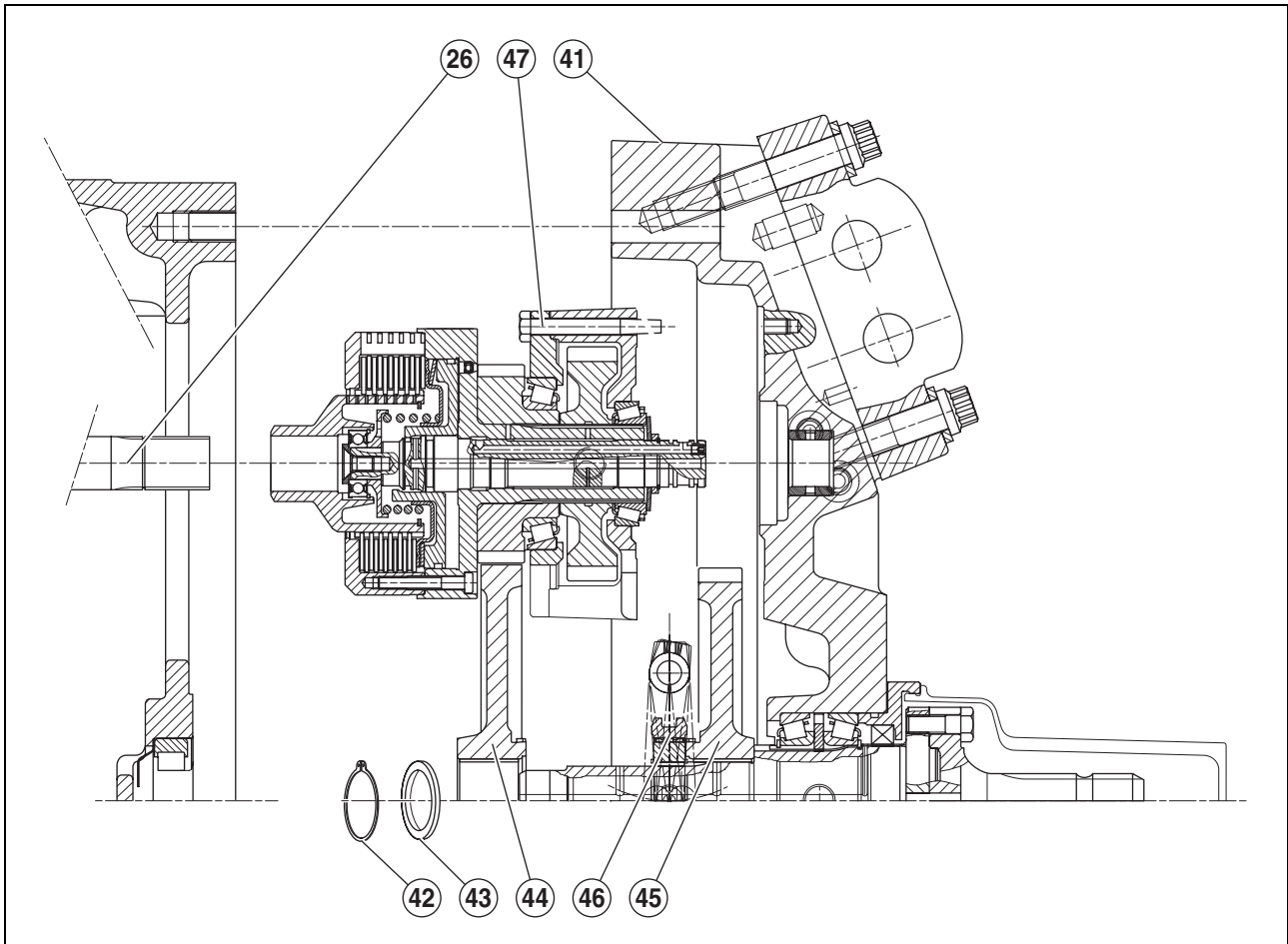

342hsm54

Fig. 47

Removal/refitting

- Drain the transmission system.
- Disconnect the PTO control cables and pipes.
- Remove the linkage and lift accessories obstructing the uncoupling of the PTO housing (41).
- Remove the rear PTO housing with a chain and hoist.
- Leave the shaft (26) in the rear axle.
- Remove the sensor located on the right-hand upper side of the PTO housing.
- Recover the friction washers from the lower shaft.
- Remove the circlip (42) and washer (43) from the lower shaft and maintain the driven gears.
- Pull the lower shaft then remove the gears (44) and (45).
- Recover the friction washers and the dog (46).
- Remove screws (47).
- Remove the clutch and upper shaft assembly.
- Remove the sealing rings (2). Using a press and a suitable jig, compress the Belleville washer (50) moderately (Fig. 48).
- Remove the circlip (48), the washer (49) - noting which way round it is fitted - and the Belleville washer (50) (Fig. 48).

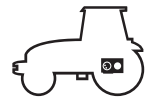

GPA 30 crawler gears

General

It is made up of a step-down gear and a dog control function. The step-down gear consists of an epicyclic gear set comprising a planet carrier and ring gear assembly located at the front of the rear axle housing. The control is

mounted on the rear axle and activates the engagement dog of the step-down gear via the fork. The dog can only be engaged at a standstill. The reduction ratio of the step-down gear is 0,25.

Parts list

1 Screw.	17 Retaining ring.	33 Ring gear.
2 Control cable support.	18 Park lock sleeve.	34 Friction washer.
3 Screw.	19 Secondary shaft.	35 Retaining ring.
4 Control link.	20 Needle bearing.	36 Pinion.
5 O-ring.	21 Retaining ring.	37 Retaining ring.
6 Spindle.	22 Sliding sleeve.	38 Crawler gear support.
7 Pin.	23 Clutching gear.	39 Screw.
8 Adjustment shims.	24 Retaining ring.	40 Bearing.
9 Lever.	25 Screw.	41 Retaining ring.
10 Nut.	26 Unit.	42 Retaining ring.
11 Guide rod.	27 Planet carrier.	43 Pin.
12 Fork.	28 Pins.	44 Gearbox shaft.
13 Lock.	29 Needles.	45 Sleeve.
14 Spring.	30 Planet gear.	46 Retaining ring.
15 Screw.	31 Friction plate.	
16 Intermediate housing.	32 Spacer.	



Replacing the master cylinders

- Drain and remove the brake fluid reservoir (10).
- Remove the braking valve control pipe (5), the two brake supply pipes (3) and the balancer pipe (4).
- Remove the defective master cylinder(s) (11) by unscrewing the nuts (6).
- Fit the new master cylinder(s) (nuts (6) torqued to 2 daN.m) and refit all previously removed components.

Adjusting the brake pedals

Adjustment procedure

- Measure the length of the pedal high end stops (A).
- Adjust the end stops (A) respecting the dimension indicated.
- Tighten the locknut (B).
- Check that the lock coupling the pedals together slides freely when the pedals are in high position.
- Adjust the length of fork joint (D) so that rod (C) comes in contact with the master cylinder piston.
- Press the brake pedal gently by hand until you clearly feel a hard point. When bearing on this point, there should be 3 mm of play between the end stop (A) and the pedal (Fig. 11). If not, screw or unscrew the push rod (C) in the fork joint (D).

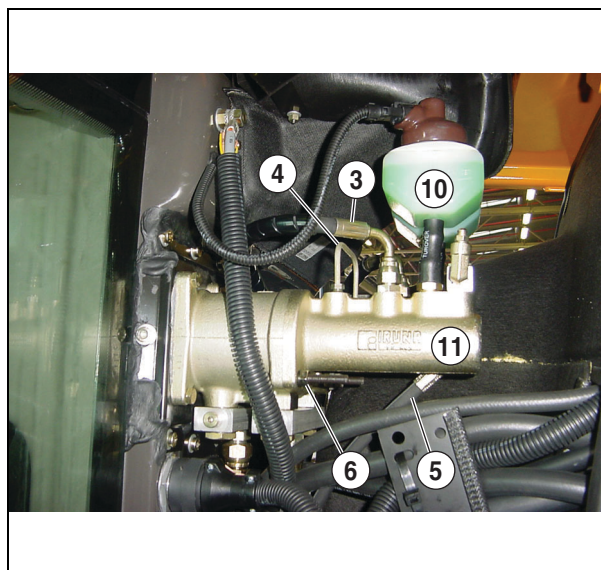

362hsm04

Fig. 10

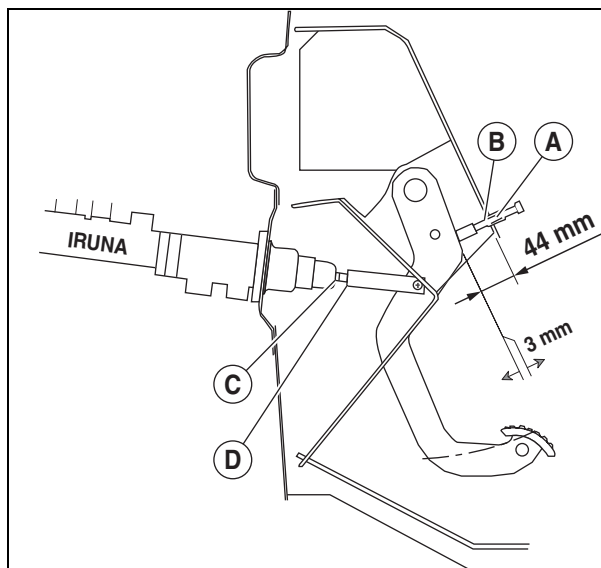

362hsm14

Fig. 11

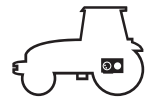

Automatic brake

Exploded view of control unit

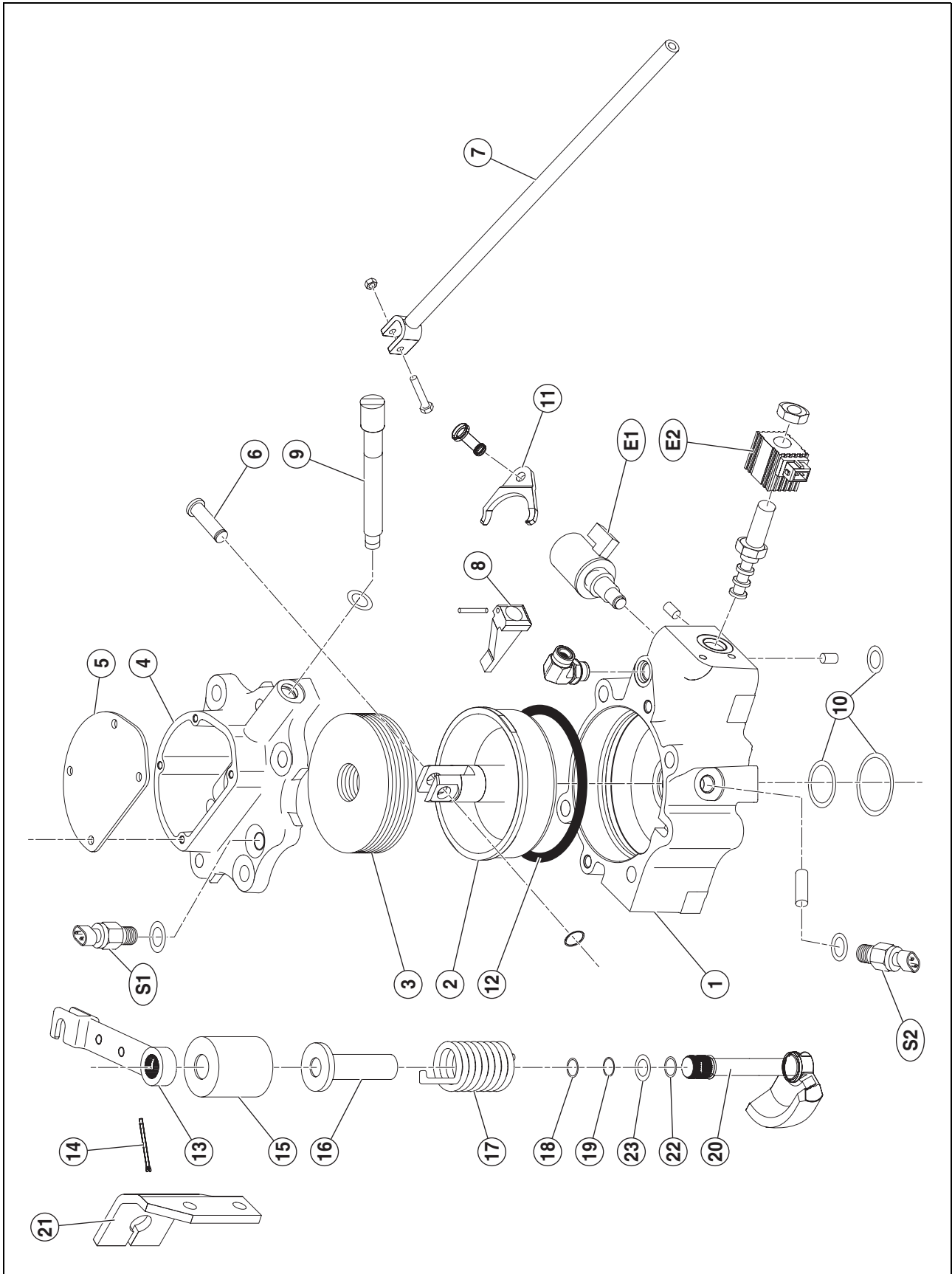

363hsm02

Fig. 4

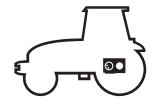

Handbrake

Remark

On the casing (4) (Fig. 27).

- Fit the bush (6) with a drift.
- Fit the seal (11) in contact with the casing (4) using a suitable jig.
- Coat the screw (2) of the cam (3) lightly with Frenetanch (242).
- Coat the contact surface of the casing (4) on the intermediate housing with Formajoint (510).
- Tighten the screw (5) to $3 \pm 0,5$ daN.m and screw (13) to $1,7 \pm 0,3$ daN.m.

N.B.: On fitting, remember the O-ring (11) which forms the seal between the pin (7) and the link (10).

On the cam (16):

- Fit the needle bearings (14) flush with face "F" (Fig. 30).
- Coat the screw (29) with Frenetanch (242) and tighten to $3 \pm 0,5$ daN.m.

On the cam (3):

- Coat the needle screw (2) with Frenetanch (242) and tighten moderately.

On the mechanism (30):

- Fit the pin (24) so that it can be removed easily.
- Coat the short thread of the tie-rod (22) lightly with Frenbloc (270) and screw into the clevis (37).

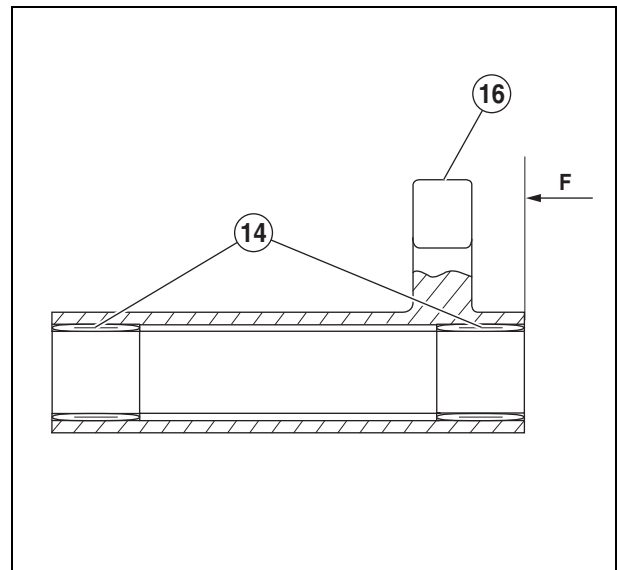



Description

General characteristics - rigid axle

Type of axle (a)	20.29	20.29-3	20.43	20.43-2
Reference (b)	136 673	147 869	141 331	147 870
Overall width (in mm) (c)	2 150		2 206	
Width between plates (in mm) (d)	1 900		1 940	
Pitch circle diameter of studs (in mm) (e)	335			
Wheel disc centring diameter (in mm) (f)	280			
Stud diameter (in mm) (g)	M 20 x 1,5			
Number of studs	10			
Maximum inner steering angle (h)	55°			
Roll angle (i)	10°			
Dynamic load capability at less than 7 km/h (in daN.m)	7 500			
Static load capability (in daN.m)	19 000			
Oil type (j)	See tractor user's manual.			
Oil capacity of epicyclic gearbox (l)	1,5 l			
Oil capacity of differential housing (k)	6 l			
Type of differential lock	Electro-hydraulic			
Number of differential discs	8			
Number of crown wheel teeth	9/32	10/30	9/32	10/30
Number of epicyclic reduction gear teeth	13/31/77			
Crown wheel reduction ratio	1/3,56	1/3	1/3,56	1/3
Epicyclic reduction ratio	1/6,92			
Total reduction ratio of axle (m)	1/24,62	1/20,769	1/24,62	1/20,769
Power take-off (driving/driven)	49/45	45/49	49/45	45/49
Front/Rear inter-axle ratio	See tractor user's manual.			
Wheel alignment	Toe-in (0/- 2)			



Removal/refitting

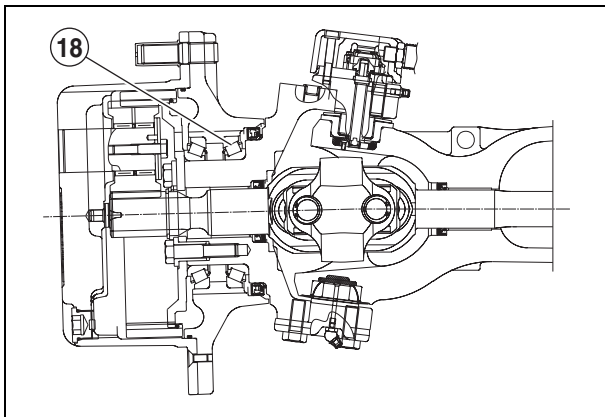

451hsm45

Fig. 24

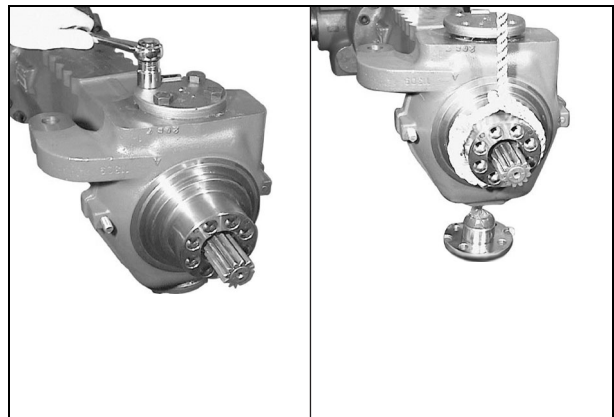

451hsm21

Fig. 25

- Remove the reduction gear and wheel hub (see paragraph concerned).
- Extract the bearing inner ring (18) with an extractor.
- Remove the angle sensor (left-hand pivot only).
- Support the wheel pivot with a hoist.
- Remove the lower (42) and upper pins (36), (48) (Fig. 23).
- Remove the Belleville washers (51) and (57).
- Extract the seal (45).
- Extract the bush (44).
- Fit the new bush (44) with tool n° 60 05 006 550.
- Grease the lip of the new seal (45).
- Fit the seal with tool n° 60 05 006 549.

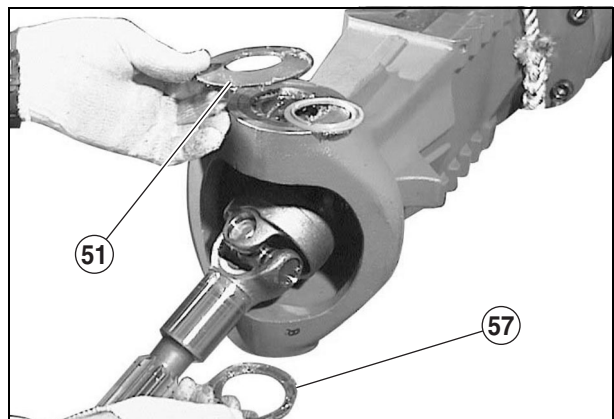

451hsm22

Fig. 26

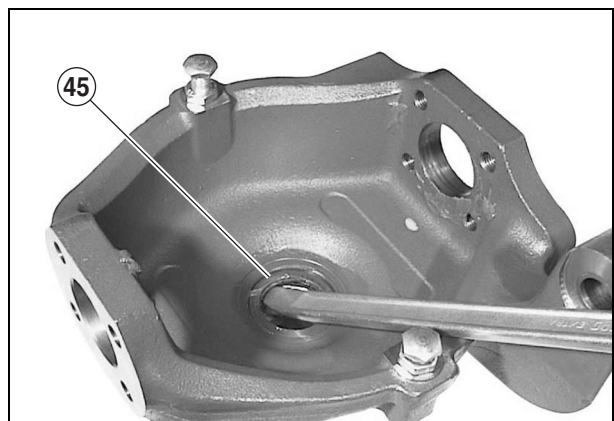

451hsm23

Fig. 27

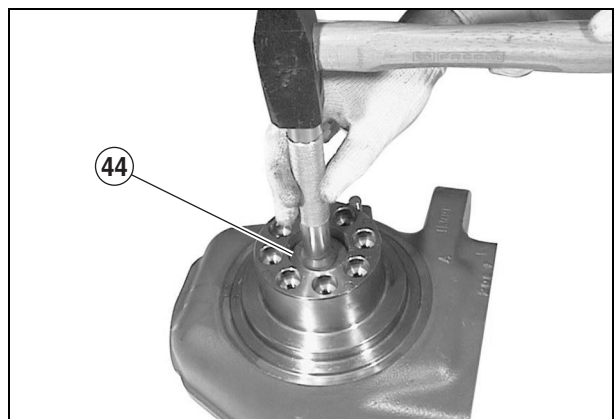

451hsm24

Fig. 28



Removal/refitting

Wheel pivot and upper arm

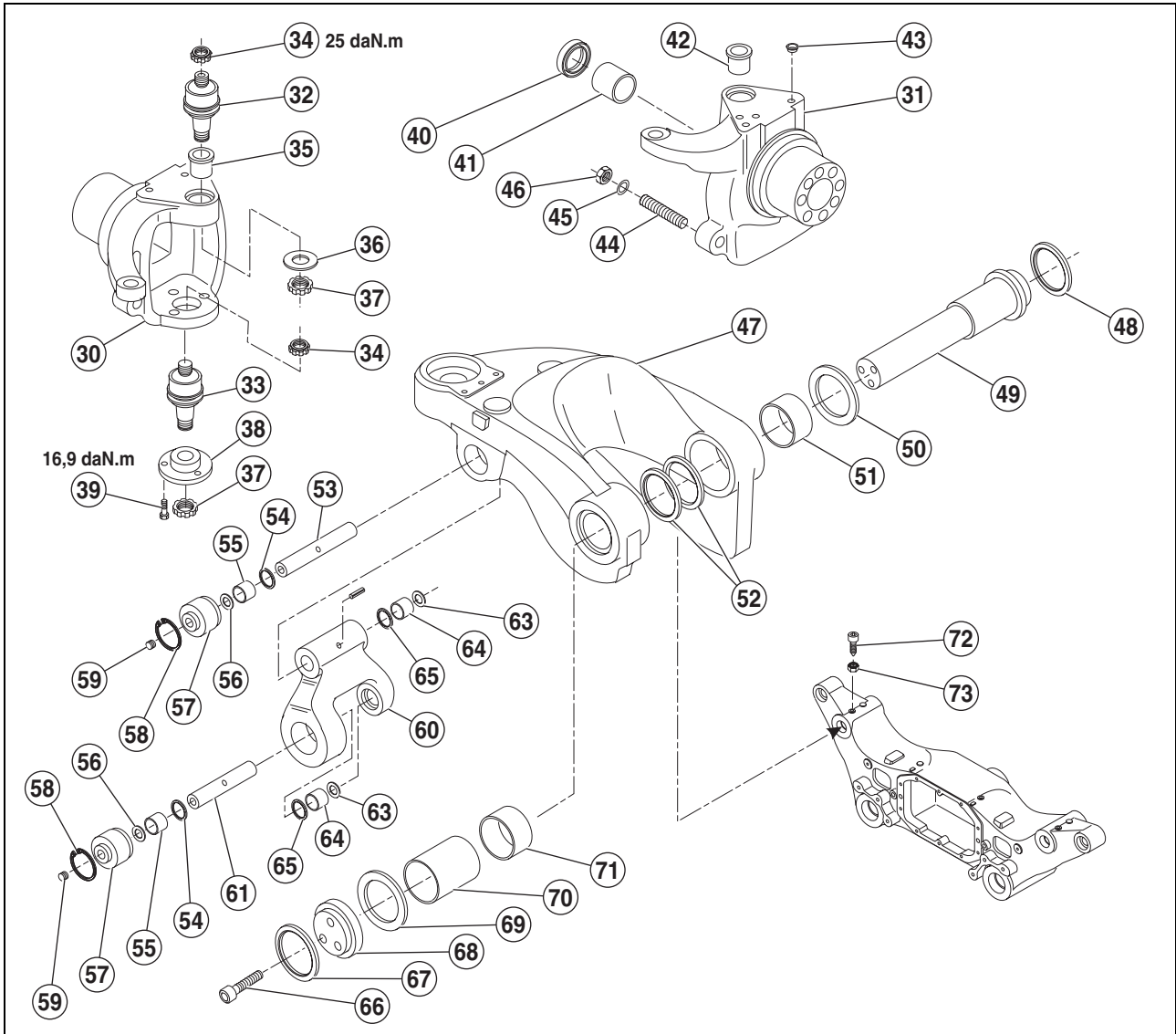

452hsm08

Fig. 16

Parts list

- | | | |
|-----------------------|-------------------|-------------------|
| 30 Left-hand pivot. | 45 Washer. | 60 Fork. |
| 31 Right-hand pivot. | 46 Nut. | 61 Lower pin. |
| 32 Upper ball joint. | 47 Upper arm. | 62 Pin. |
| 33 Lower ball joint. | 48 Seal. | 63 Washer. |
| 34 Nut. | 49 Spindle. | 64 Bush. |
| 35 Bush. | 50 Washer. | 65 Seal. |
| 36 Belleville washer. | 51 Bush. | 66 Screw. |
| 37 Nut. | 52 Seal. | 67 Seal. |
| 38 Flange. | 53 Upper pin. | 68 Cover. |
| 39 Screw. | 54 Seal. | 69 Washer. |
| 40 Seal. | 55 Bush. | 70 Bush. |
| 41 Bush. | 56 Washer. | 71 Bush. |
| 42 Bush. | 57 Centring bush. | 72 Locking screw. |
| 43 Plug. | 58 Circlip. | 73 Locknut. |
| 44 Steering stop. | 59 Grub screw. | |



Removal/refitting

- Finish fitting the torsion bar (118) (the arm must be raised to the cylinder limit).

N.B.: Observe the marks made earlier.

- Fit the circlip.
- Tighten the needle screw (116) by hand as far as it will go. This approach point will be the zero position before preloading the bar.
- Tighten the screw by 7,5 turns with a spanner.
- Tighten the locknut (117) to a torque of 4,5 daN.m.
- Tighten the screws in the rear flange (115) to a torque of 16,9 daN.m.
- Position the front and rear flange covers.

Refitting the upper arm

- Screw on new grease nipples.
- Smear the 2 pivots with grease.
- Fit the 2 wear bushes (71) and (51) and the 2 lip seals (52) (lips on the inside and spring towards the outside of the arm) using tool n° 60 05 006 559 and tool n° 60 05 006 555.
- Fit the 2 brass washers (50) with the embossed side facing the outside of the arms.
- Smear the 2 pivots with grease.

Universal shafts

N.B.: To remove the seals, the wheel pivot needs to be removed first of all.

Universal shaft, wheel side

- The universal shaft can easily be extracted once the wheel pivot has been removed.
- Check the shafts and splines.
- Replace the spiders (131) if worn or damaged (Fig. 49).

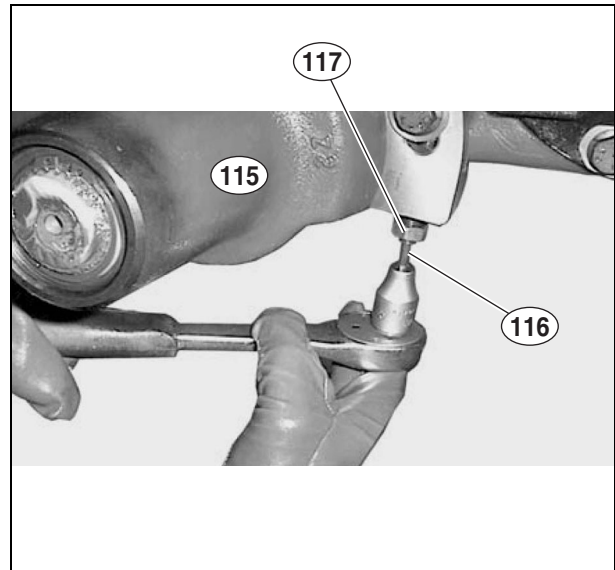

452hsm38

Fig. 46

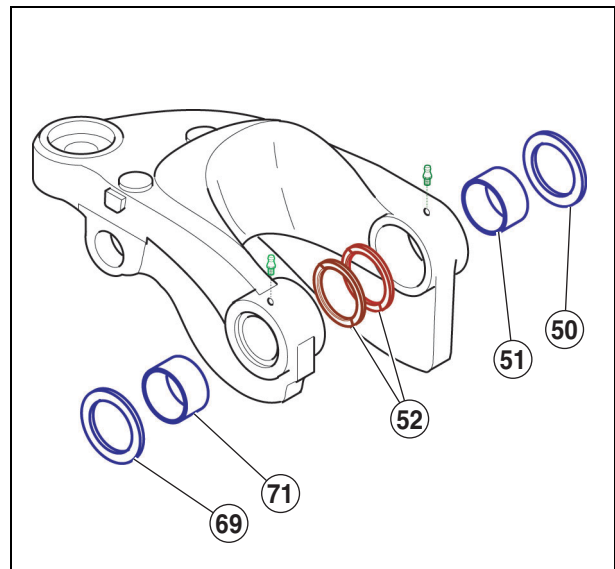

452hsm39

Fig. 47

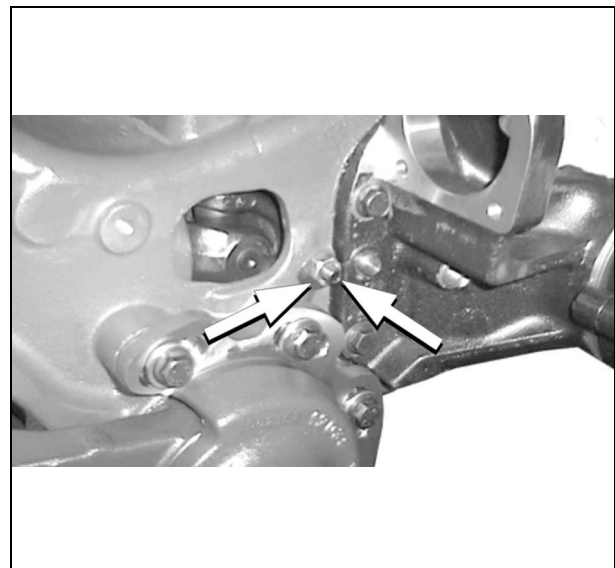

452hsm40

Fig. 48

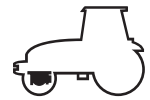

Removal/refitting

Sectional view

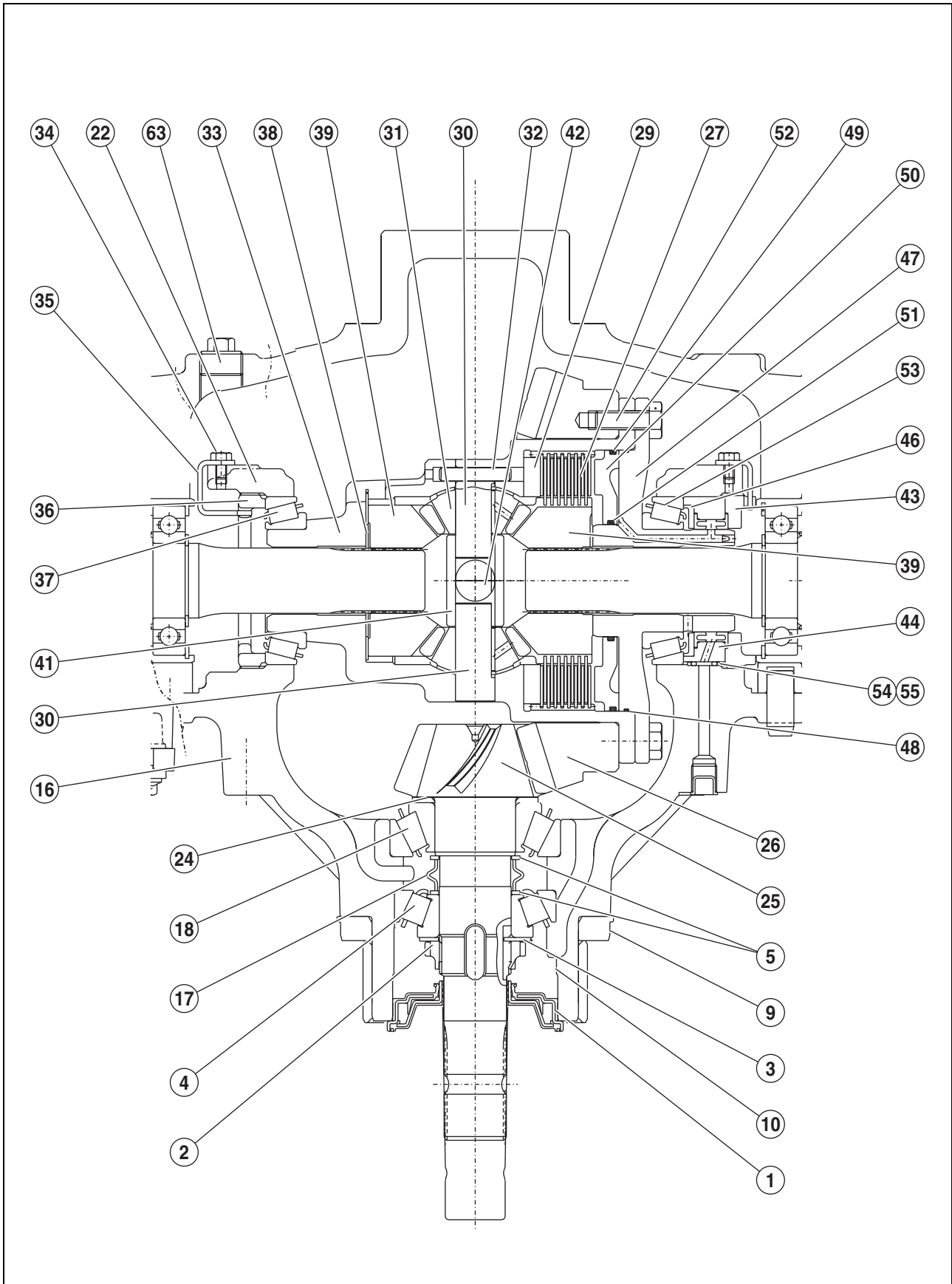

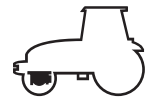

Hydraulic measurement and checking points

Test conditions.

- Transmission oil temperature: 60°C.
- Engine running at nominal speed.
- Suspension disabled.

Suspension cylinder pressure check

N.B.: Check that the tractor's hydraulic functions are working properly before testing the axle hydraulic circuit.

To check the suspension cylinder pressure, connect pressure gauge n° 60 05 705 076 and adapter n° 60 05 005 306 directly to the cylinder outlet.

- The pressure at the start of the suspension rising phase should be 130 bar for a tractor equipped with a front lift .
- The pressure at the end of the rising phase should reach 150 bar (depending on the weight of the masses or the lift).
- The accumulators should take 20 seconds to inflate. The suspension system should take 6 seconds to rise.

Nominal value	Measured value	Nominal value	Measured value
Start pressure	Pressure	End pressure	Pressure
130 bar		150	

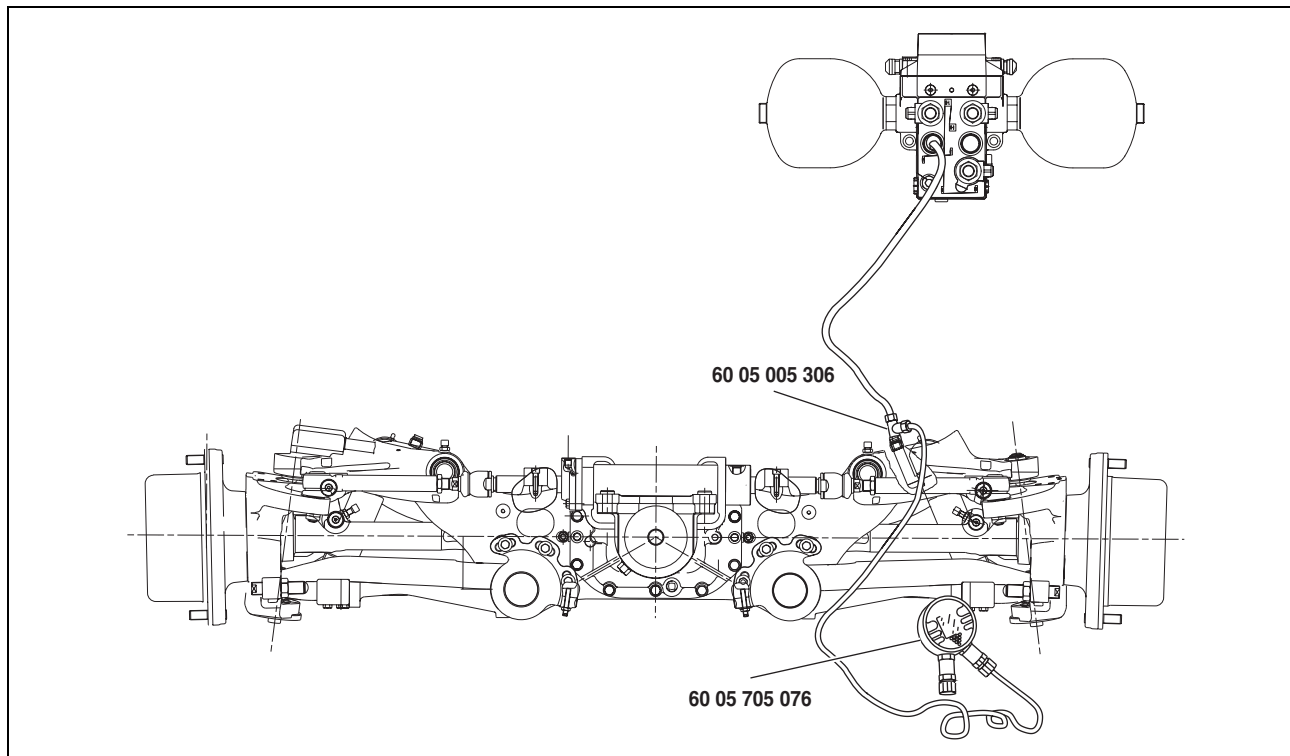

452hsm64

Fig. 92

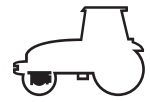

Description

Cross-sectional view of the 4-wheel drive housing(GPA 40 axle)

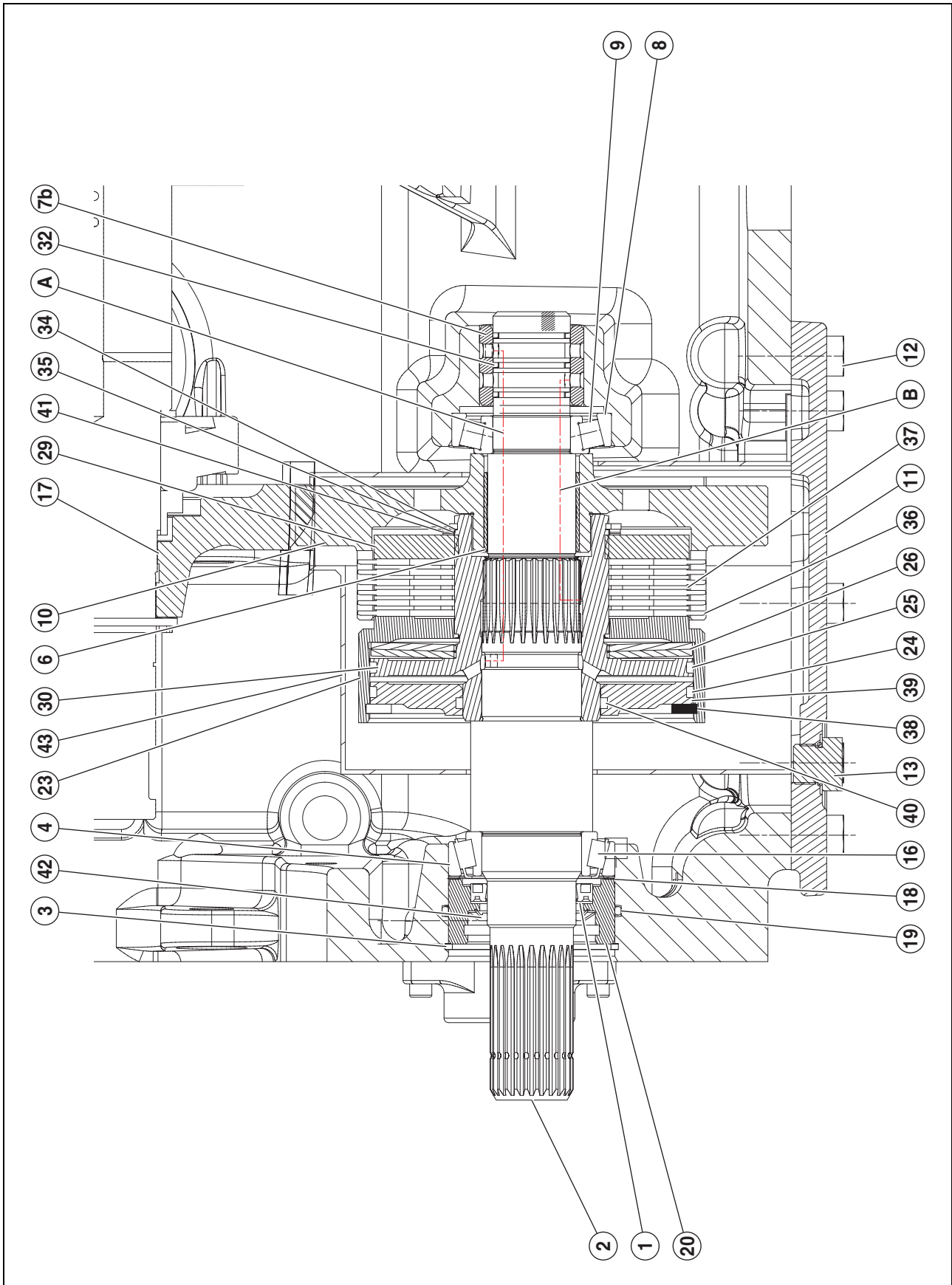

473hsm09

Fig. 4



Front axle – 4 WD power take-off housing

60 05 005 306

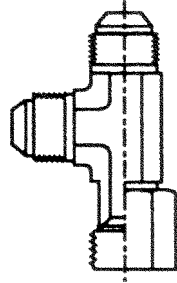

Adapter for measuring suspension cylinder pressure

60 05 005 718

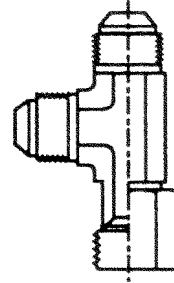

Adapter for measuring differential lock pressure

60 05 005 734

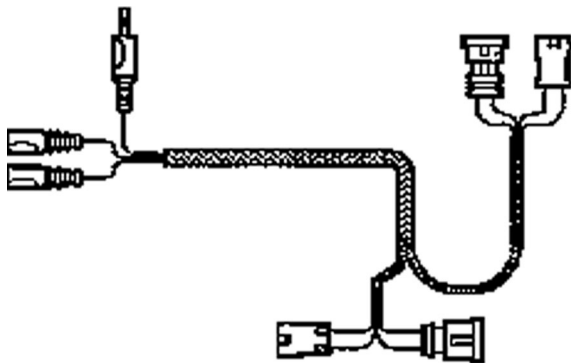

Solenoid valve test harness

60 05 006 534

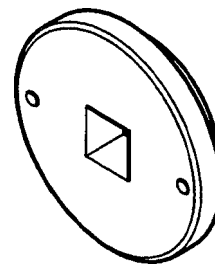

Wrench for differential nut

60 05 006 535

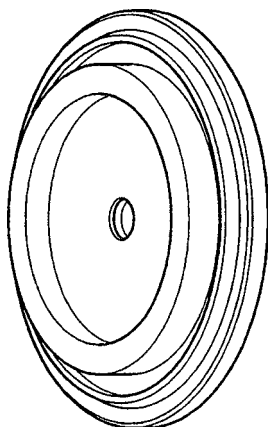

Tool for fitting seal to wheel hub

60 05 006 536

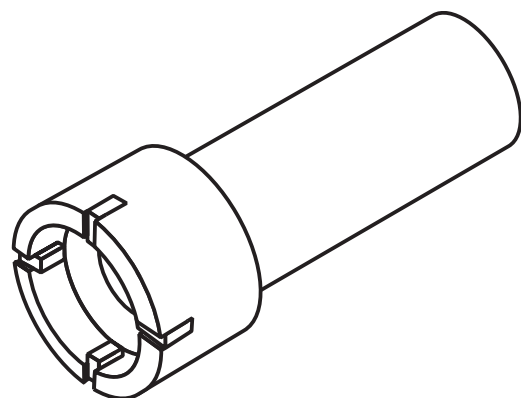

Wrench for conical pinion nut

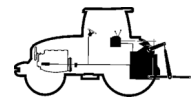

HYDRAULIC MEASUREMENT AND CHECKING POINTS

CHECKING THE STANDBY PRESSURE OF THE 14 CM ³ PUMP	E2.23
PRESSURE CHECK FOR A FLOW RATE OF LESS THAN 40-L/MIN AND A FLOW RATE OF 60 L/MIN	E2.25
TEST AT 20 L/MIN	E2.26
TEST AT 20 L/MIN	E2.26
MINIMUM/MAXIMUM FLOW RATE CHECK ON THE AUXILIARY SPOOL VALVES	E2.27
BRAKING VALVE CHECK	E2.27

"HYDRAULIC INSPECTION RESULTS" SHEET

MINIMUM/MAXIMUM FLOW RATE CHECK ON THE AUXILIARY SPOOL VALVES	E2.28
CHECKING THE STANDBY PRESSURE OF THE 14 CM ³ PUMP	E2.28
CHECK THE PRESSURE FOR A REQUIRED FLOW LESS THAN 40 L/MIN AND A FLOW OF 60 L/MIN	E2.28

HYDRAULIC MEASUREMENT AND CHECKING POINTS

CHECKING THE STEERING PUMP	E2.29
MAXIMUM STEERING CYLINDER PRESSURE CHECK	E2.30
SHOCKPROOF VALVE OPENING PRESSURE CHECK.....	E2.32

"HYDRAULIC INSPECTION RESULTS" SHEET

CHECKING THE STEERING PUMP	E2.33
MAXIMUM STEERING CYLINDER PRESSURE CHECK	E2.33
SHOCKPROOF VALVE OPENING PRESSURE CHECK.....	E2.33

TOOLS

HYDRAULIC CIRCUIT TOOLING	E2.36
---------------------------------	-------

CLICK HERE TO **DOWNLOAD** THE COMPLETE MANUAL

- Thank you very much for reading the preview of the manual.
- You can download the complete manual from: www.heydownloads.com by clicking the link below



- Please note: If there is no response to CLICKING the link, please download this PDF first and then click on it.

CLICK HERE TO **DOWNLOAD** THE COMPLETE MANUAL

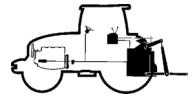

Removing/refitting the components

External view of right-hand cover with brake valve

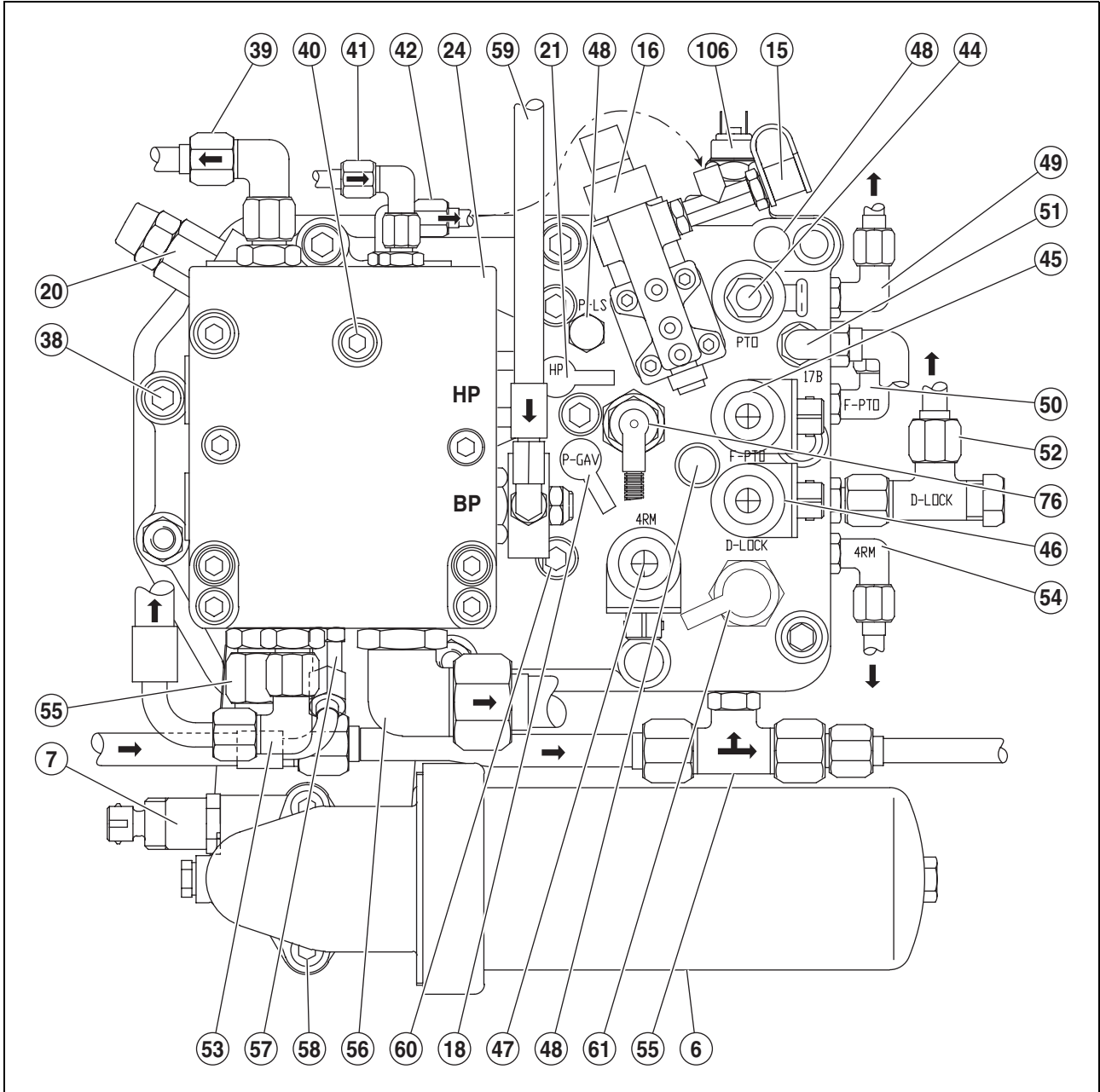

391hsm06

Fig. 10

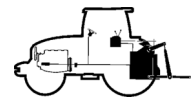

Removing/refitting the components

Exploded view of the left-hand cover

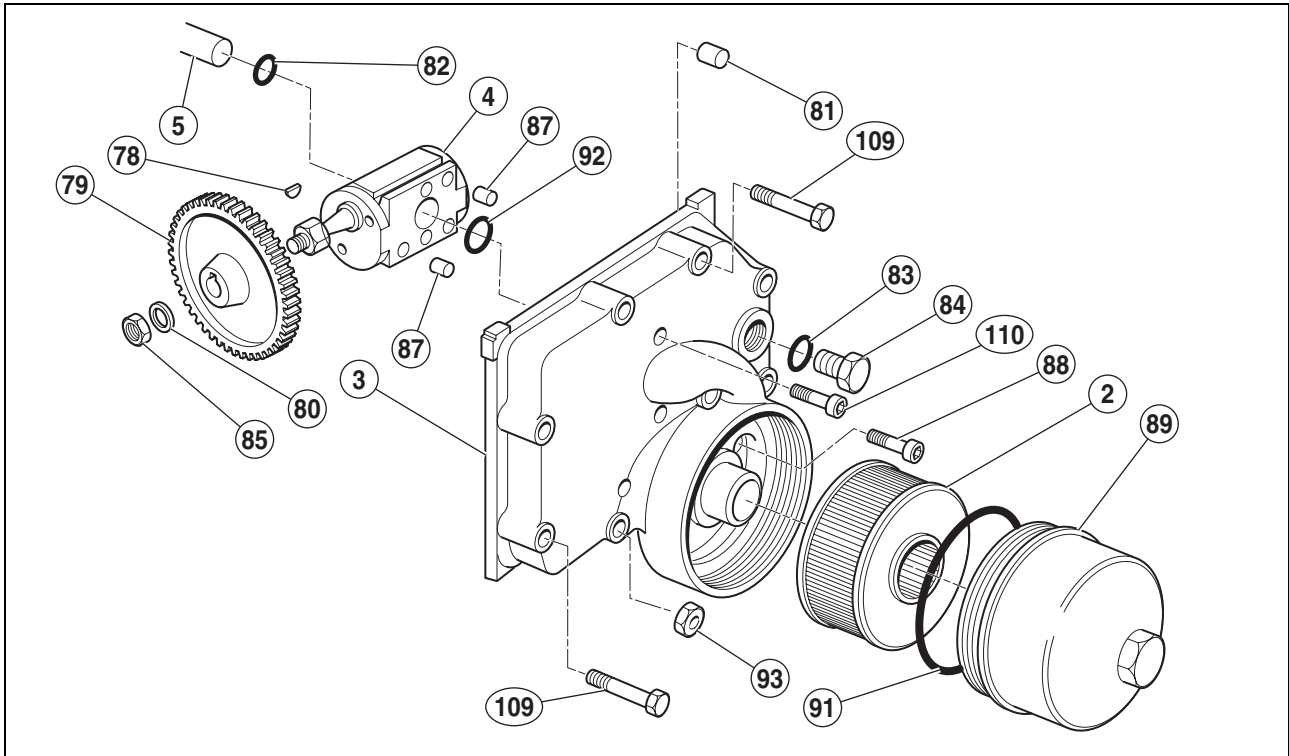

391hsm20

Fig. 26

Sectional view of the left-hand cover

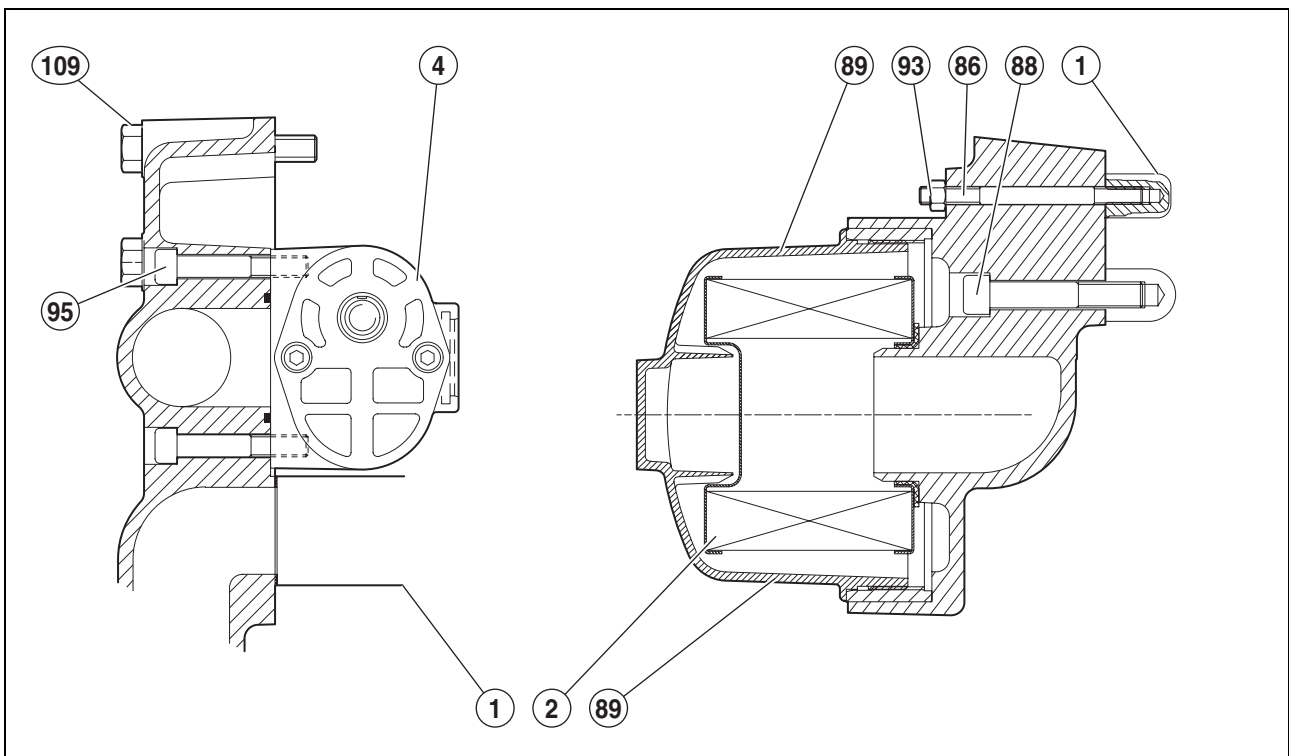

391hsm21

Fig. 27

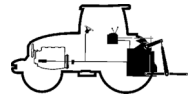

Removing/refitting the components

Linkage spool valve

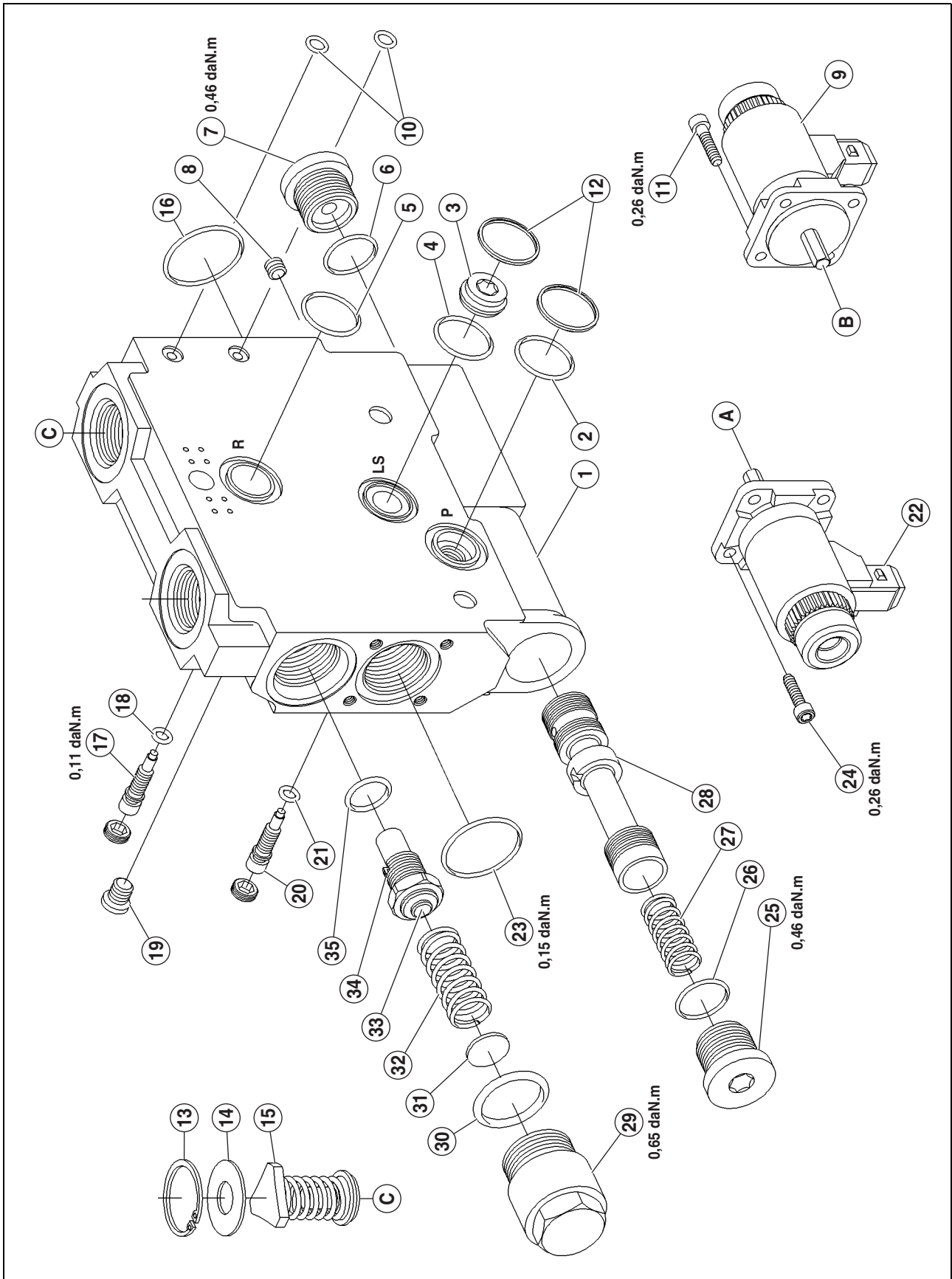

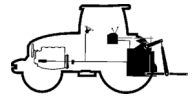

Description

Auxiliary spool valve control adjustments

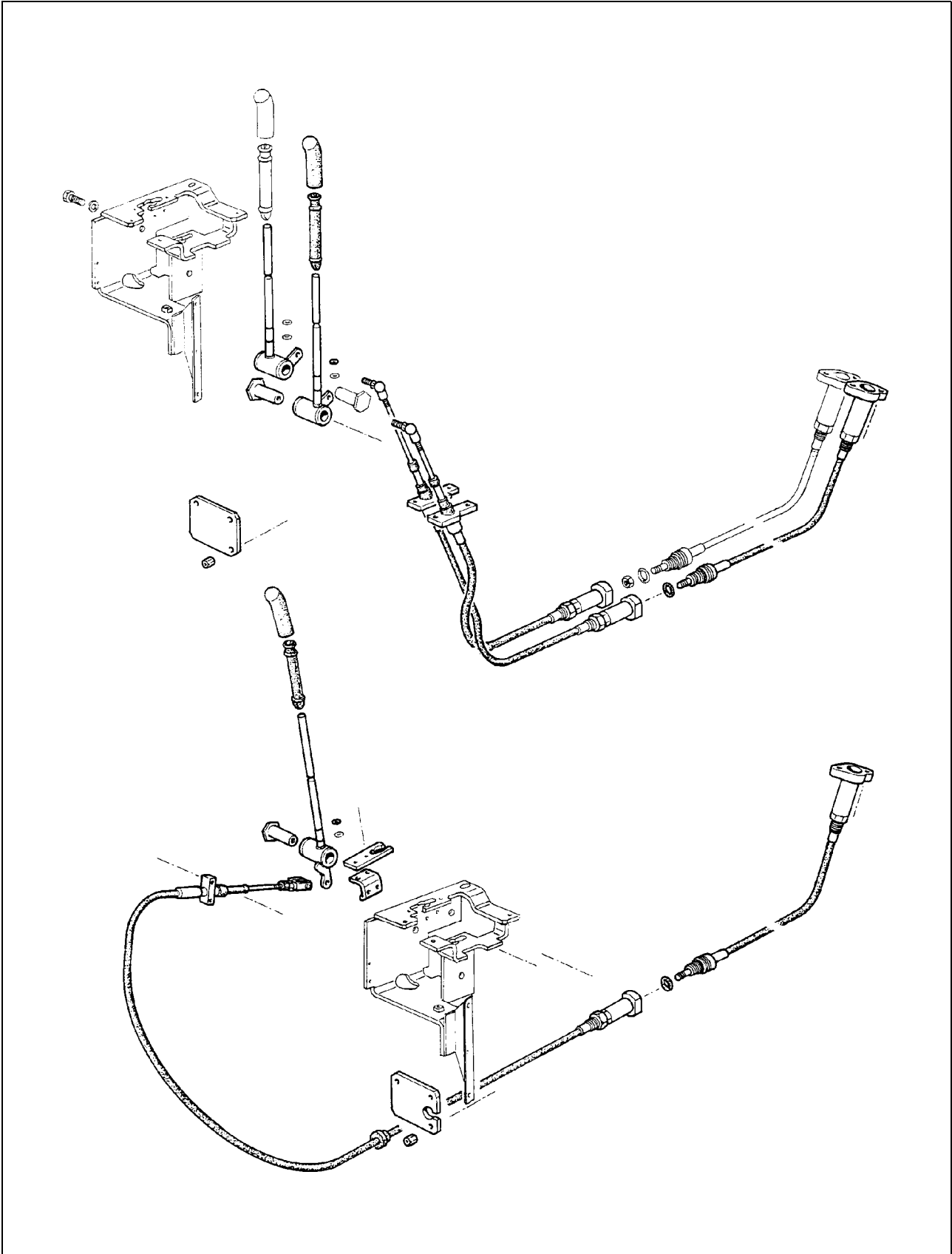

393hsm10

Fig. 56

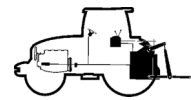

Removing/refitting the components

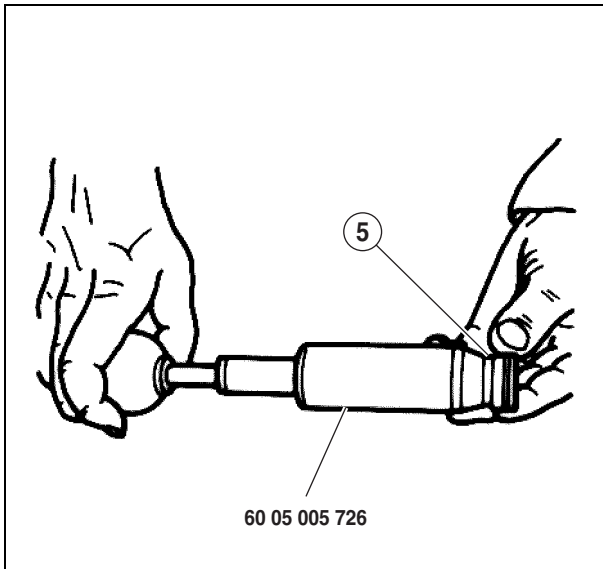

491hsm09

Fig. 70

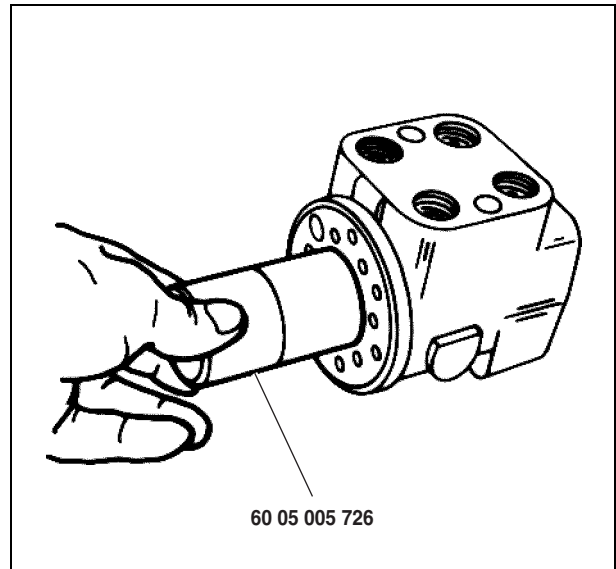

491hsm10

Fig. 71

Specific points relating to removal/refitting

Always change all seals and gaskets whenever the unit is removed.

- Check the surface conditions of the parts (slide, sleeve, bores in the body, etc.).

Fitting the ring seal

- Fit the ring seal (5) onto the end of tool n° 60 05 005 726.
- Oil the seal.
- Place the fitting sheath of tool n° 60 05 005 726 on the body (Fig. 70).
- Insert the seal holder into the sheath (Fig. 71).
- Push fully in.
- Remove the sheath and the fitting tool (the end stays in place).

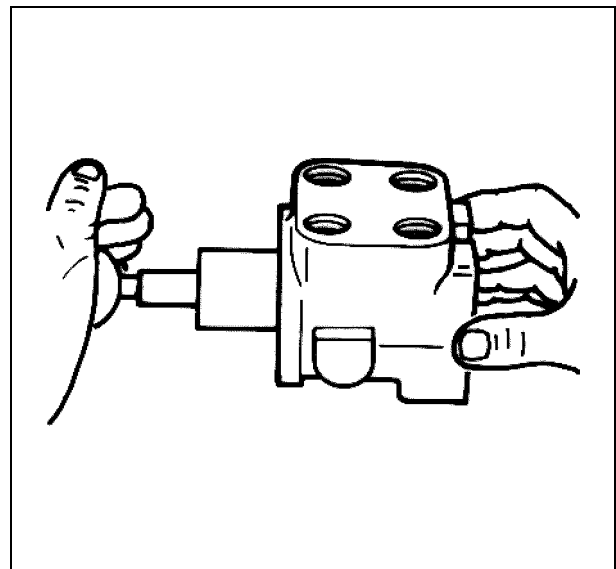

491hsm12

Fig. 72



Ensure that the roller thrust bearing (4) is fitted the right way round.

- Position the inner thrust washer (4b) with the chamfer facing the sleeve (1) (Fig. 73).

4. Roller bearing.

4b. Inner thrust washer.

4c. Outer thrust washer.

1. Distribution sleeve.

24. Rotary slide.

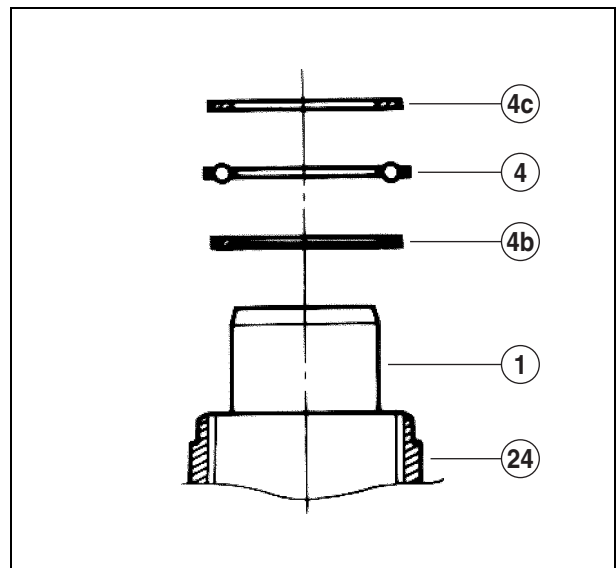

491hsm11

Fig. 73

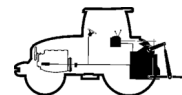

"Hydraulic inspection results" sheet

This sheet is intended to be duplicated and completed for each operation on the tractor. If you have to send it to the manufacturer's after sales service, it is essential to indicate:

- Tractor type
- The serial number
- Total operating hours
- Date of operation

Steering pressure check

Test conditions Oil temperature at 60°C	Nominal values		Recorded values	
	Pressure P2 in bar	Pressure P3 in bar	Pressure P2 in bar	Pressure P3 in bar
Engine running at 1 000 rpm	149 ± 2	170 ± 2		

Maximum steering cylinder pressure check

Test conditions Oil temperature at 60°C	Nominal value (bar)	Measured value (bar)
Engine running at 1 000 rpm	155 to 165	

Shockproof valve opening pressure check

Test conditions Oil temperature at 60°C	Nominal value (bar)	Measured value (bar)
With the engine stopped	225 to 245	

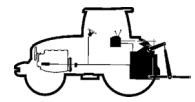

Removing/refitting the components

Sectional view of the braking valve (Bosch)

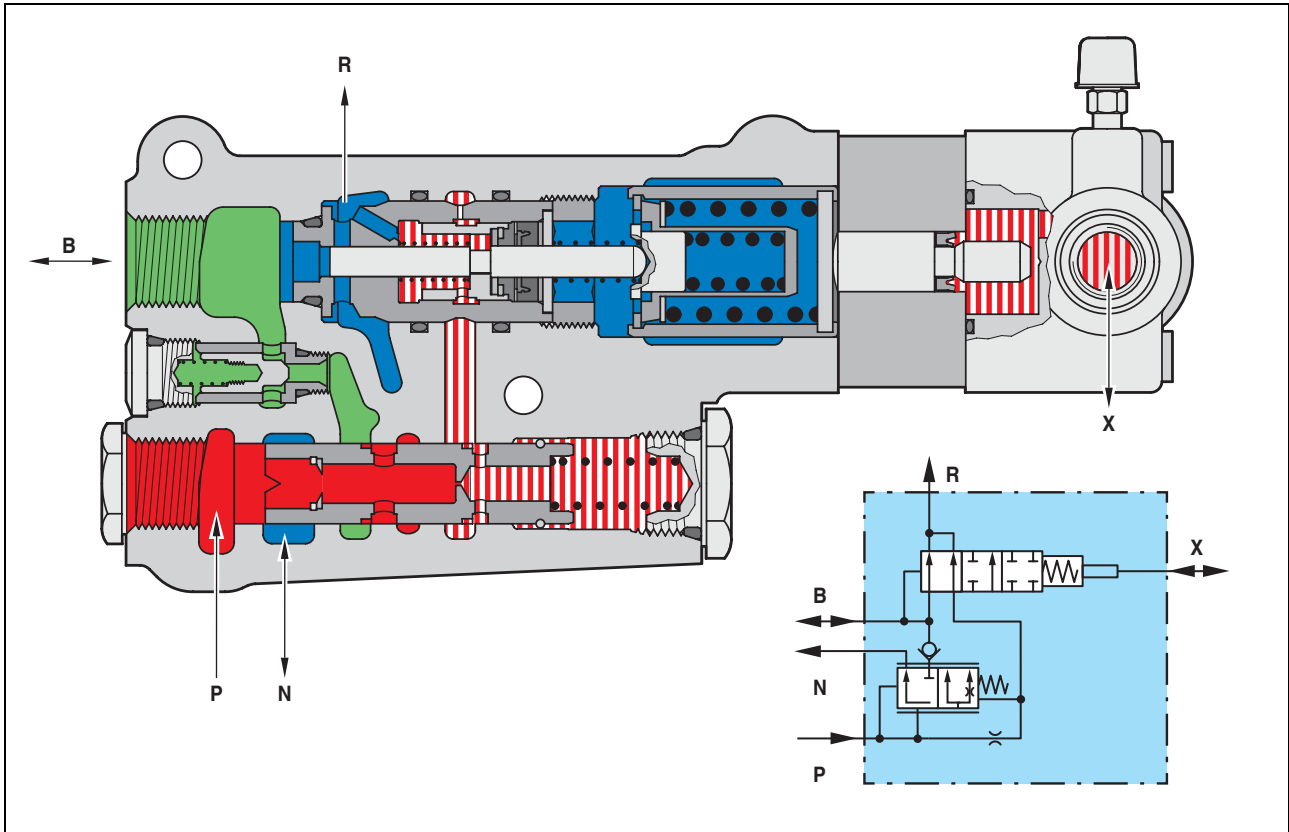

391hsm05

Fig. 10

Parts list

- | | | |
|-----------------|--------------------|--|
| 64 Spool. | 82 Spring. | 100 Valve socket. |
| 65 Spool. | 83 Washer. | 101 Valve. |
| 66 Guide bush. | 84 O-ring. | 102 Spring. |
| 67 Sleeve. | 85 Plug. | 103 O-ring. |
| 68 O-rings. | 86 Spring. | 104 Plug. |
| 69 Pushrod. | 87 Plunger rod. | 105 Valve body. |
| 70 Bleed screw. | 88 Thrust washer. | 106 Plug. |
| 71 Spring. | 89 Flat seal. | 107 Plug. |
| 72 O-ring. | 90 Bush. | 108 Seal. |
| 73 Pushrod. | 91 Valve head. | 109 Plug. |
| 74 Seal. | 92 O-ring. | 110 Pushrod. |
| 75 Washer. | 93 Coupling. | B Supply to trailer brake coupling. |
| 76 Screw. | 94 Expanding plug. | N Continuity to auxiliary spool valve. |
| 77 Circlip. | 95 Needle screw. | P Pressure. |
| 78 Spring. | 96 Cap. | R Return to the casing. |
| 79 Circlip. | 97 Seal. | X Supply from tractor braking device. |
| 80 Screen. | 98 Plug. | |
| 81 Circlip. | 99 O-ring. | |

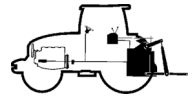

Hydraulic measurement and checking points

N.B.: On tractors equipped with a (SNR) braking valve, the pressure coupling (B) of the 19 cm³ pump is located vertically (Fig. 26).

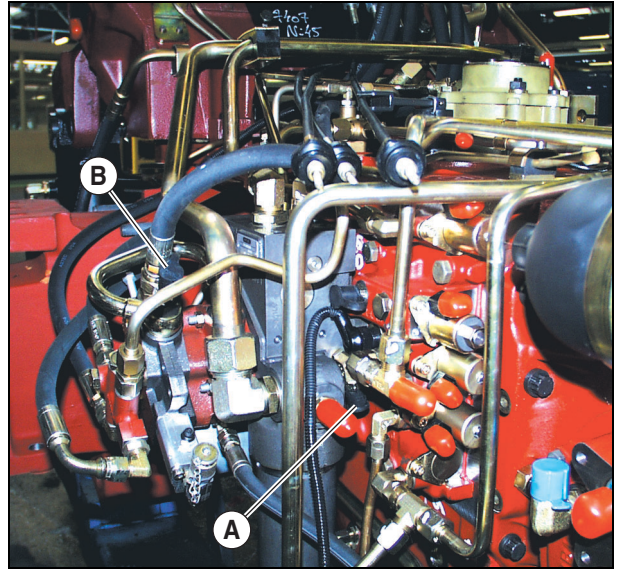

392hsm36

Fig. 26

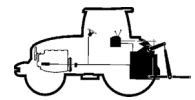

Hydraulic circuit tooling

60 05 005 718

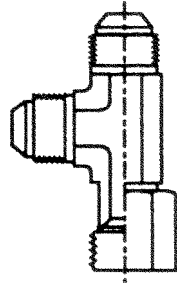

Hydraulic coupling

60 05 005 726

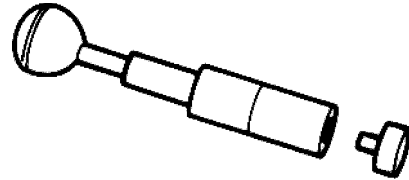

Column seal fitting tool

60 05 005 736



Hydraulics test set

60 05 705 076



Test set

60 05 712 800



Decontamination station

60 05 712 971

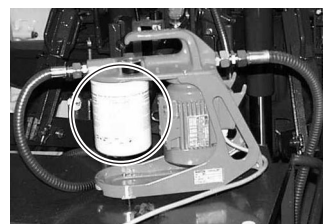

Decontamination station filter



CONTENTS

FUSE AND RELAY BOX	F1.8
DE10 STARTING/CHARGING/PREHEATING CIRCUIT	F1.12
VP44 STARTING/CHARGING/PREHEATING CIRCUIT	F1.13
DIPPED HEADLIGHTS - HEADLIGHTS - HORN - SIDE LIGHTS - INSTRUMENT PANEL LIGHT	F1.14
ROTATING BEACONS.....	F1.15
FRONT WORK LIGHTS	F1.16
REAR WORK LIGHTS.....	F1.17
STOP LIGHTS - FRONT AXLE ENGAGEMENT - AIR BRAKE SYSTEM SOLENOID VALVE CONTROL	F1.18
FLASHING LIGHTS AND WARNING LIGHTS.....	F1.19
CIGAR LIGHTER - CLOCK - RADIO - CAB LIGHT AND SPOT	F1.20
PNEUMATIC SEAT - FRONT POWER TAKE OFF CLUTCH.....	F1.21
FRONT AND REAR WINDSCREEN WIPER / WASHER.....	F1.22
INSTRUMENT PANEL VENTILATION.....	F1.24
INSTRUMENT PANEL VENTILATION AND AIR CONDITIONING.....	F1.25
INFOTRAC ON-BOARD COMPUTER / ISO SOCKET	F1.26
FUEL GAUGE - ENGINE TEMPERATURE OIL PRESSURE - AIR FILTER BLOCKED	F1.28
HANDBRAKE - BRAKE FLUID LEVEL	F1.29
ENGINE SPEED	F1.30
INSTRUMENT PANEL CALIBRATION - DIAGNOSTIC SOCKET INSTRUMENT PANEL AND TCE 15T.....	F1.31
ELECTROPILOT/DRIVETRONIC/GTA 103-202/GPA 40 DIAGNOSTIC SOCKET	F1.32
ELECTROPILOT/DRIVETRONIC/FPS DIAGNOSTIC SOCKET	F1.33
25 A POWER SOCKET	F1.34
TRANSMISSION HYDRAULIC PRESSURE - OIL FILTER BLOCKED (HP) - OIL FILTER BLOCKED (SUCTION).....	F1.35
THEORETICAL SPEED	F1.36
INSTRUMENT PANEL - REAR POWER TAKE-OFF SPEED.....	F1.37
TCE 15T LIFT	F1.38
ELECTROPILOT (WITH TCE 15T)	F1.42
LIFT TCE - 15/25/35/ RADAR	F1.44
ELECTROPILOT (WITH TCE 15/25/35).....	F1.46
GTA 103-202 - GPA 40 CLUTCH AND DRIVE CONTROL.....	F1.48
AUTOMATIC HAND BRAKE	F1.51
FPS CLUTCH AND DRIVE CONTROL	F1.52
FPS PARK LOCK	F1.55
QUADRISHIFT II	F1.56
QUADRACTIV GTA 103-202 - GPA 40.....	F1.60
FPS QUADRACTIV	F1.64
DE10 ENGINE CONTROL	F1.68
VP44 ENGINE CONTROL.....	F1.70
SUSPENDED FRONT AXLE.....	F1.72
FRONT AXLE ENGAGING - DIFFERENTIAL AND REAR POWER TAKE OFF	F1.74
OIL TEMPERATURE SENSORS - ENGINE SPEED - FORWARD SPEED - REAR POWER TAKE-OFF SPEED - REVERSER MODULE SPEED - DRIVETRONIC.....	F1.76
CROSS CONTROL WITH SOLENOID PILOT	F1.77
CROSS CONTROL	F1.78
DE10 CAN	F1.79
VP44 CAN	F1.80



Stop lights - Front axle engagement - Air brake system solenoid valve control

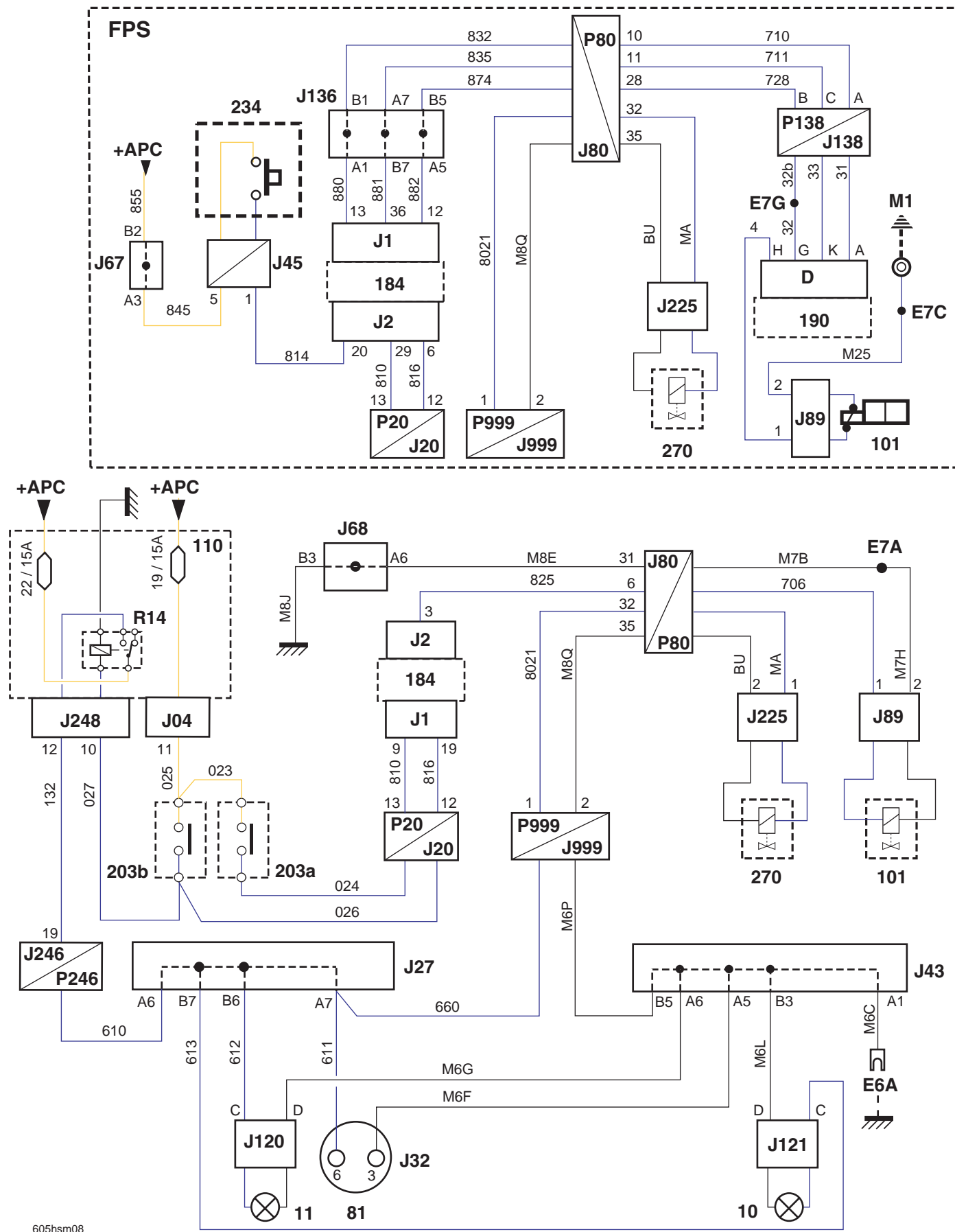

Ref	Item
10	RH rear side light
11	LH rear side light
81	Trailer signalling socket
101	4-wheel drive solenoid valve
110	Fuse box
184	Transmission electronic central unit
203a	RH brake pedal switch
203b	LH brake pedal switch
270	Air brake solenoid valve

Wire markers	Wire	2	J1	Ending
9	810	0,75	LH stop	P20 13
19	816	0,75	RH brake light	P20 12

836	835	831	830	889	827	M8L	841	834	8000	8001	
892	8008	818	809	877	816	896	814	812	811	897	876
875	866	865	861	815	817	819	810	885	869	870	

Wire markers	Wire	2	J2	Ending
3	825	0,75	4-wheel drive solenoid valve	J80 6

M8G	M8H	839	805	856	852	813	837	878	851	806	807
850	804	803	802	901	864	808	874	832	8022	M8S	
867	868	825	826	822	823	821	871	884	872	862	824

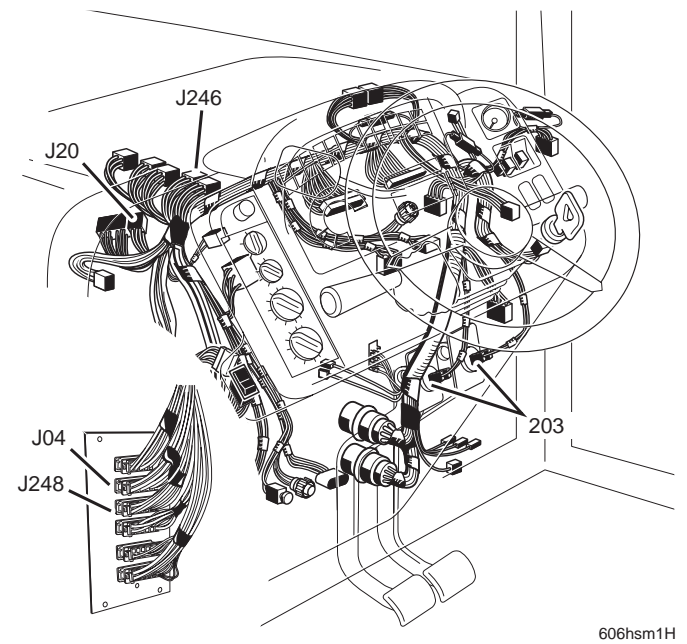

Wire markers	Wire	2	J32	Ending
3	M6F	2	Trailer socket earth	J43 A5
6	611	1	Trailer brake lights	J27 A7

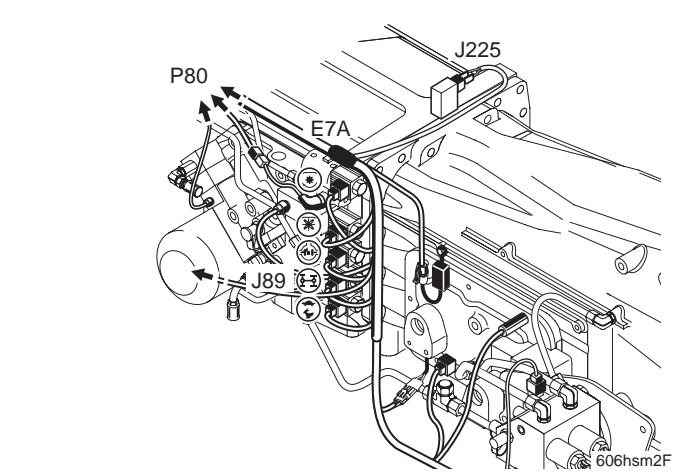
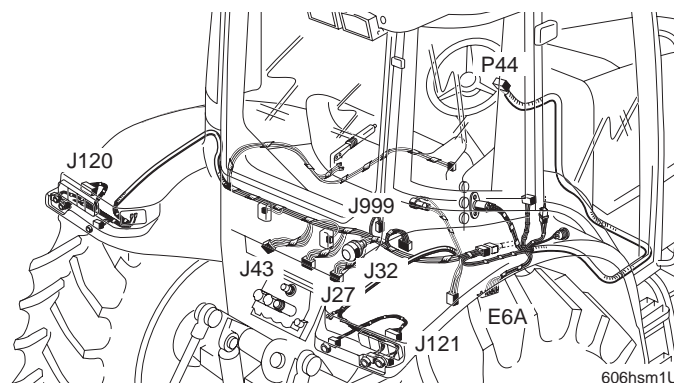
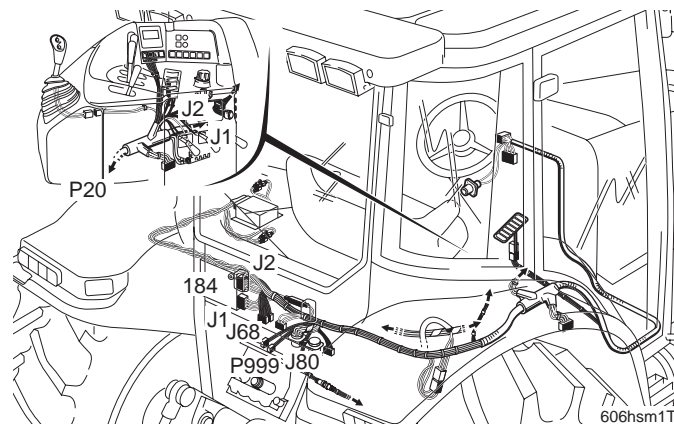
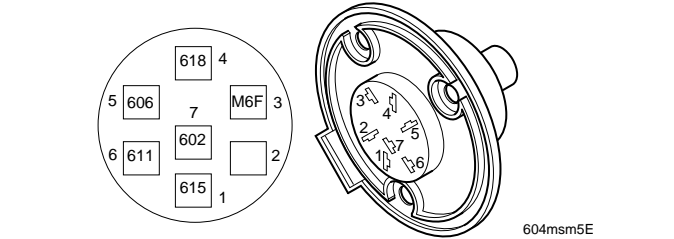

605hsm08

606hsm1H



Engine speed

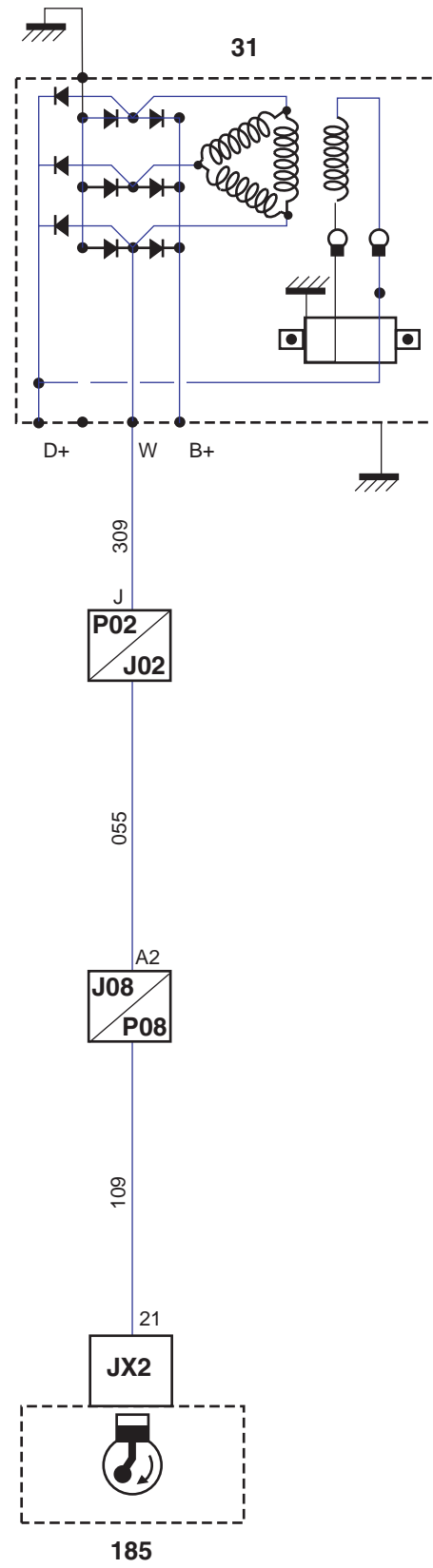

605hsm17

Ref	Item
31	Alternator
185	Instrument panel

A - Battery under lateral exhaust pipe

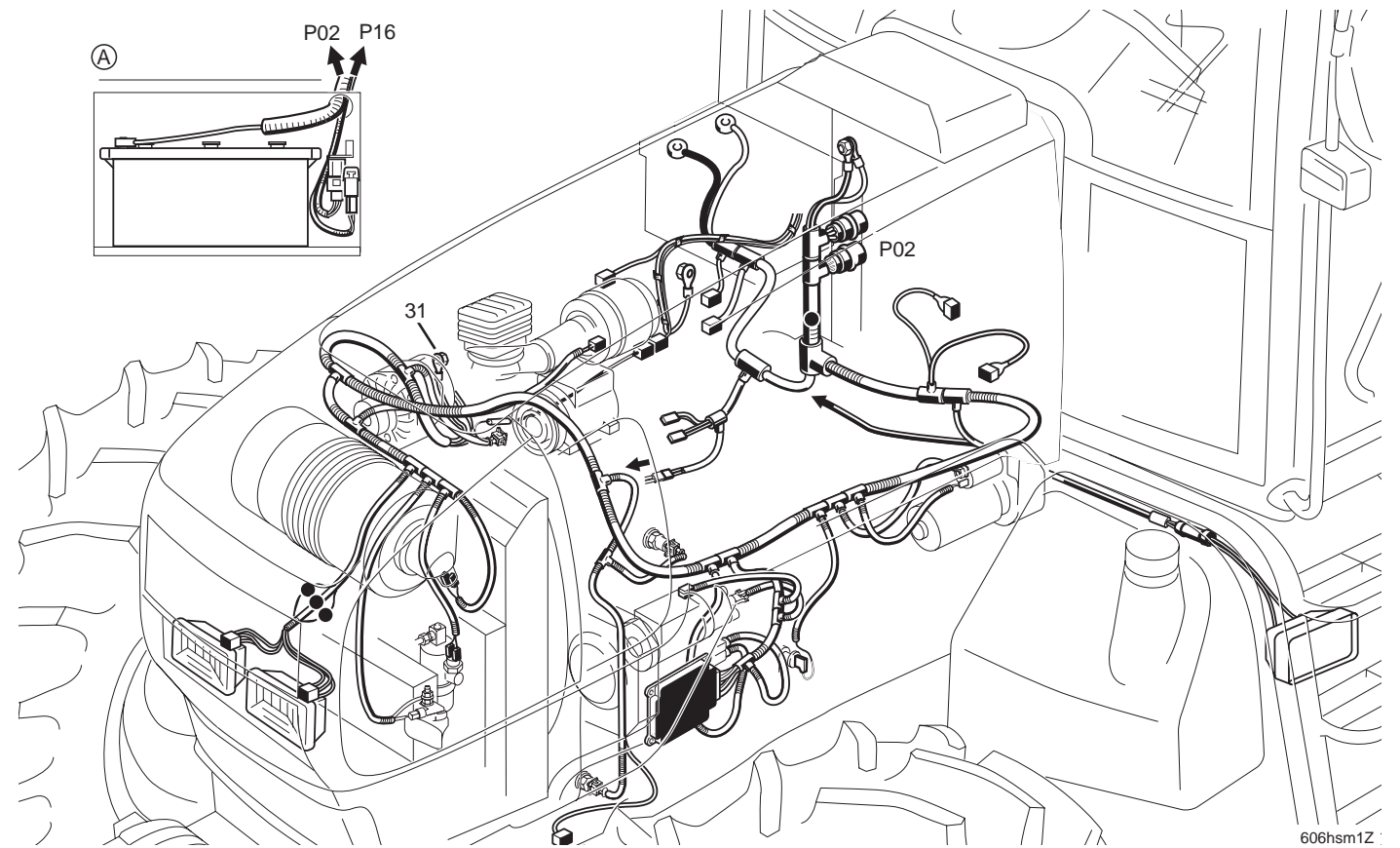

606hsm1Z

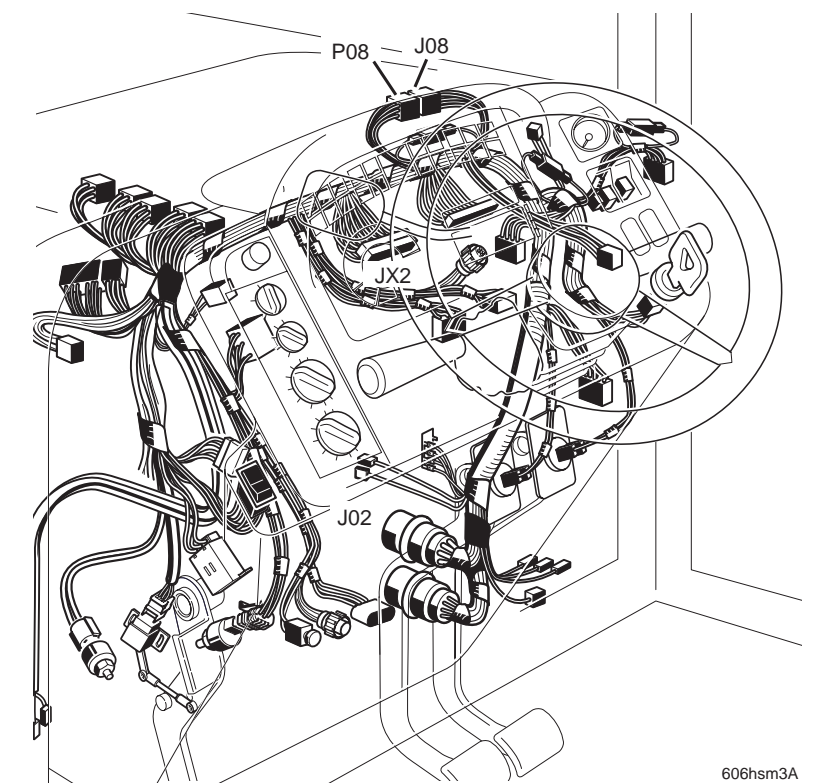

606hsm3A



Electropilot (with TCE 15T)

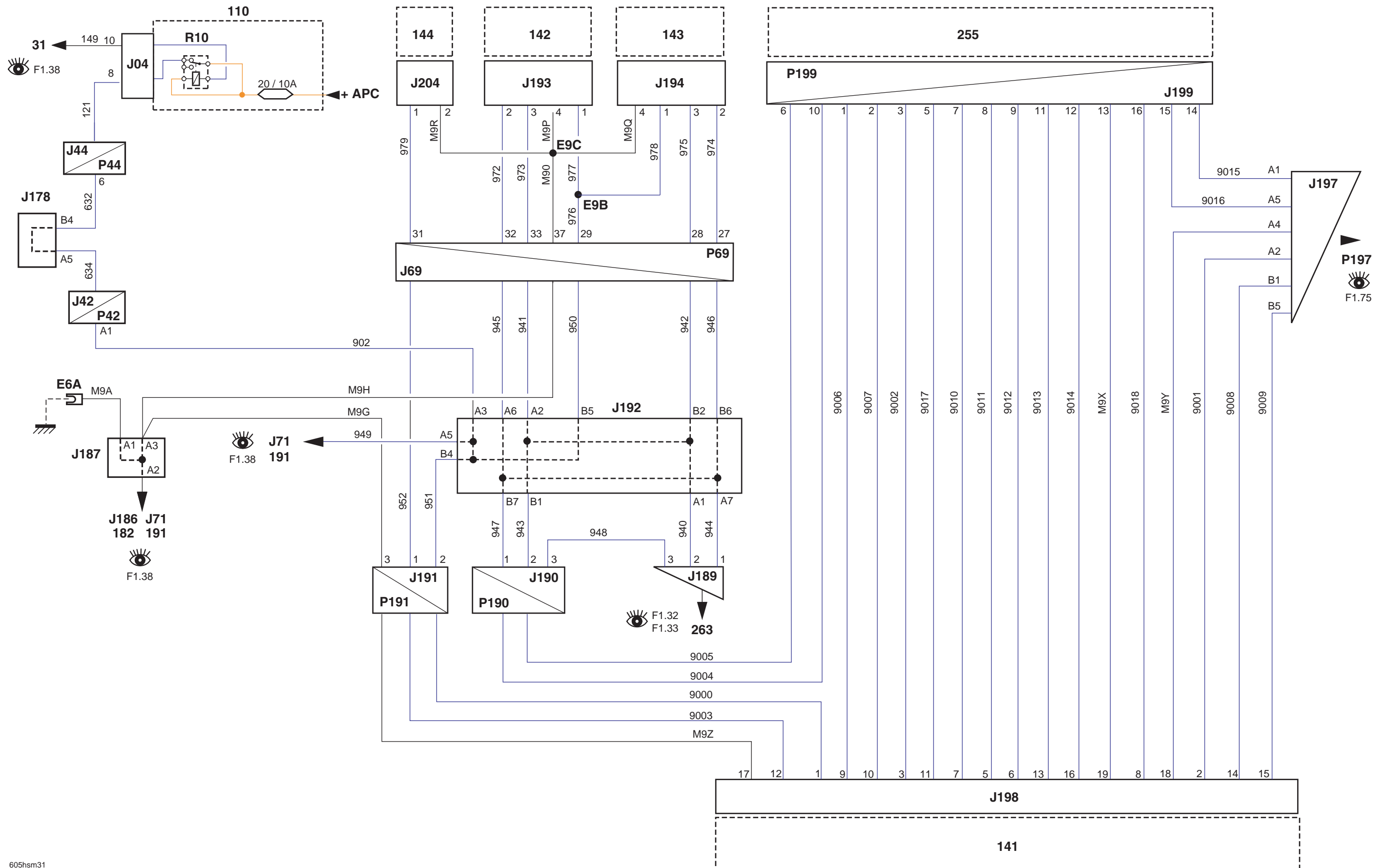



FPS clutch and drive control

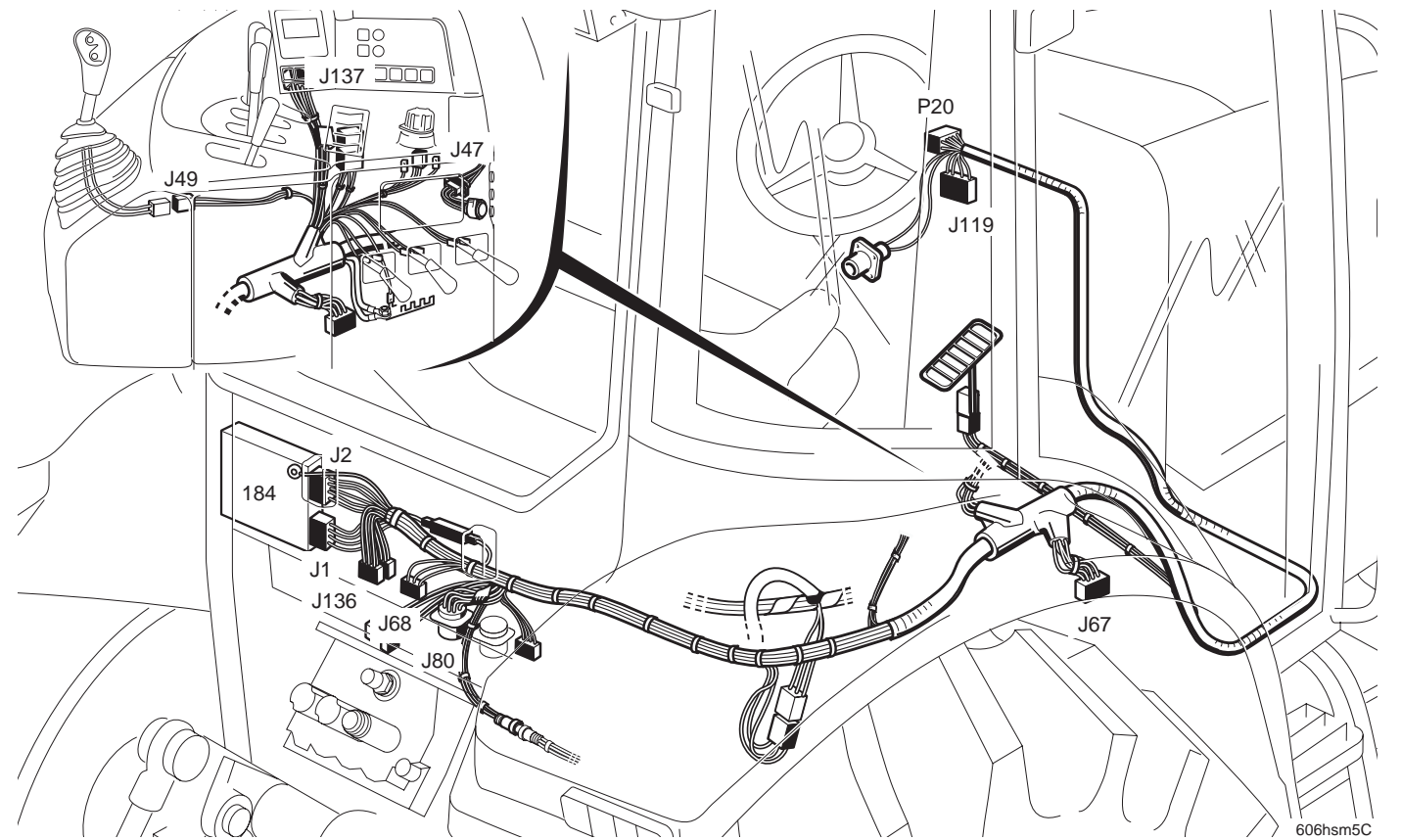
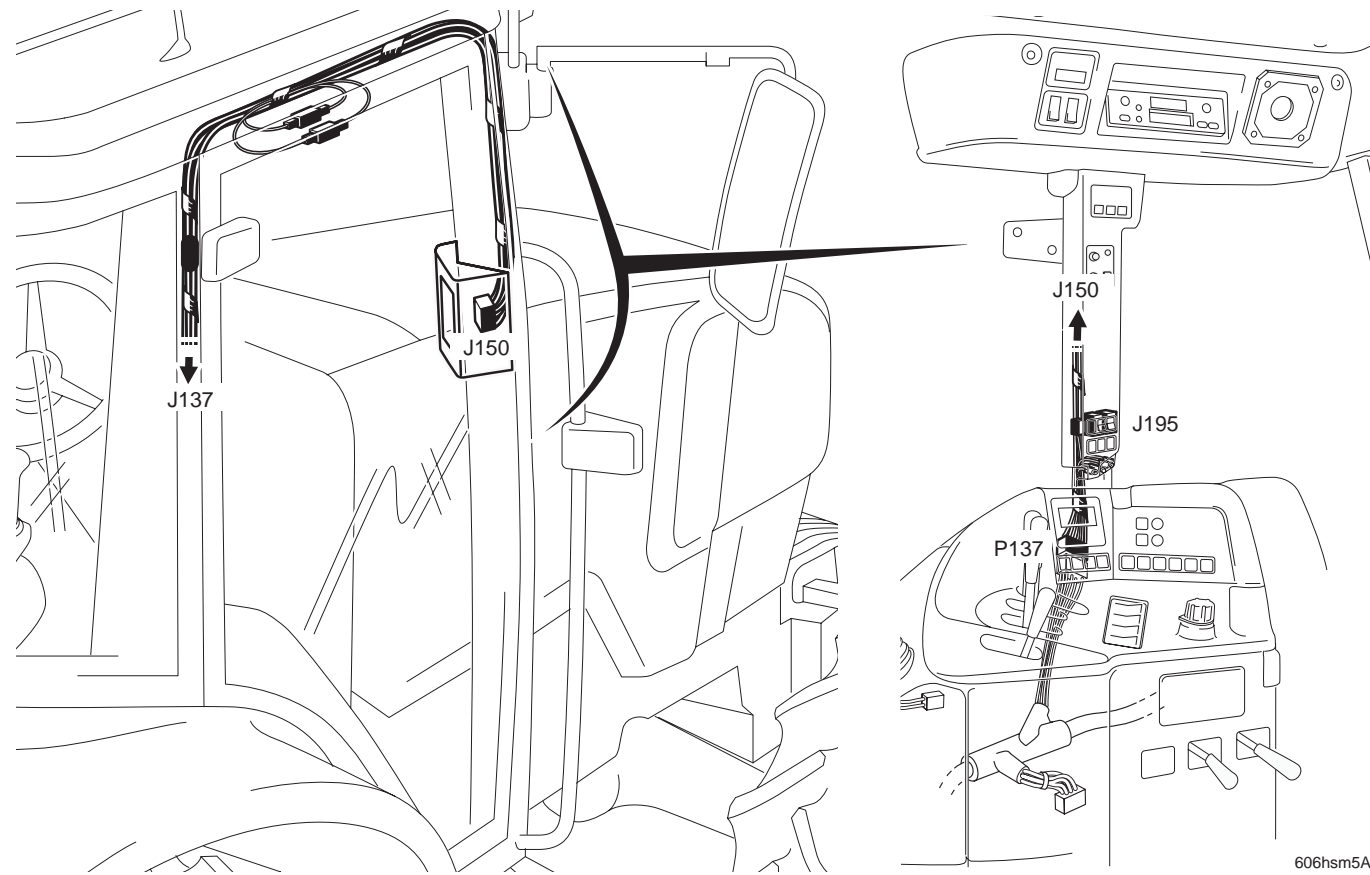
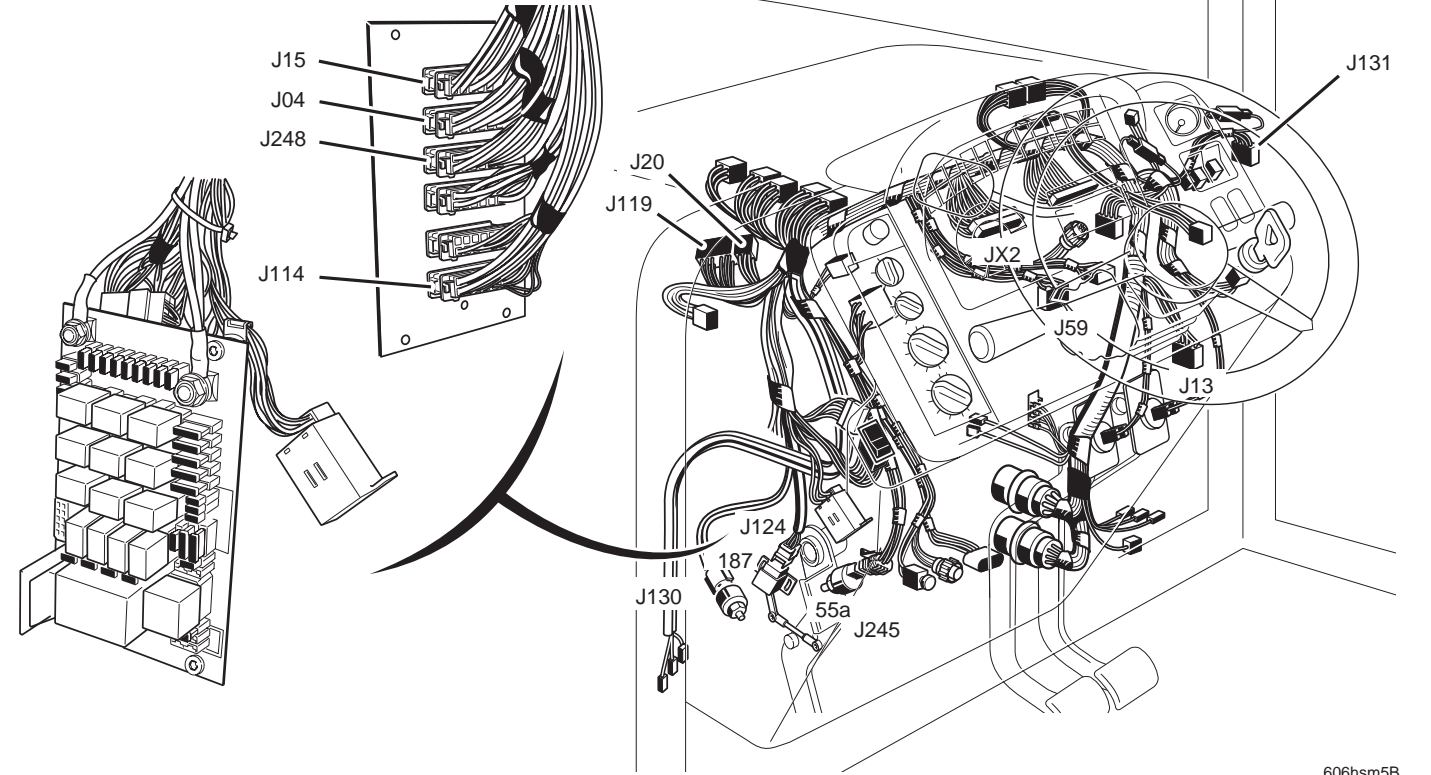
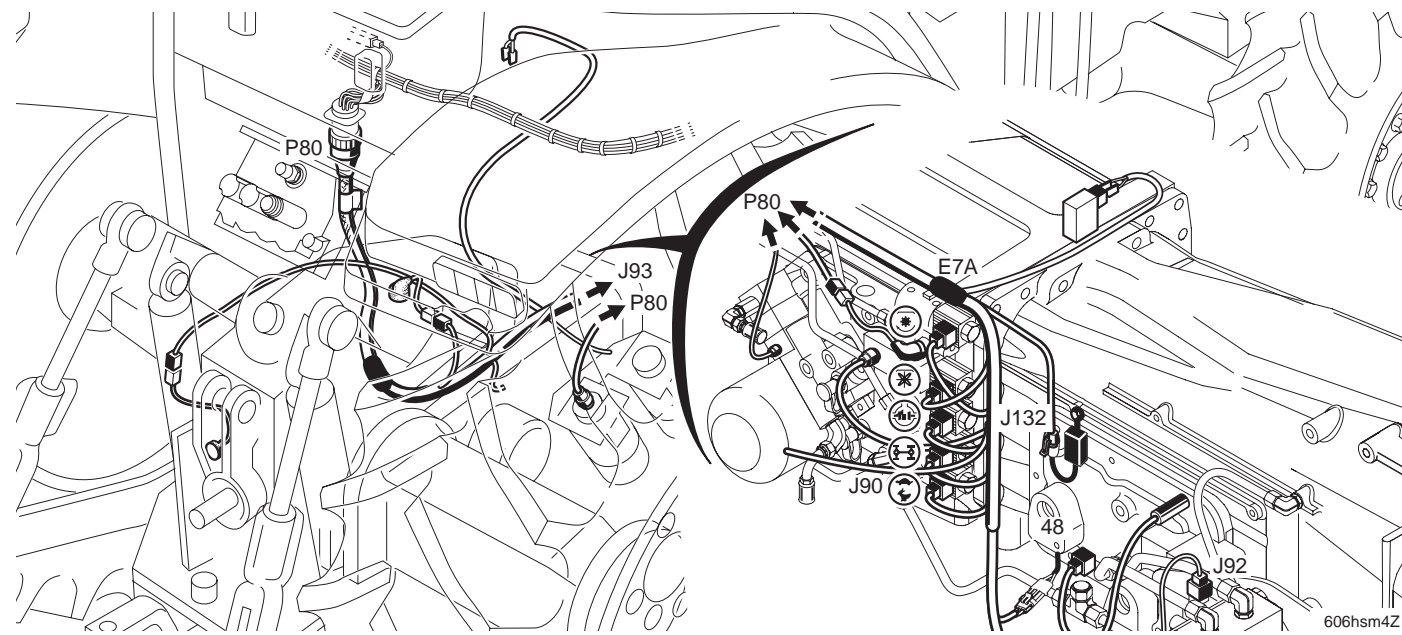



FPS unit control

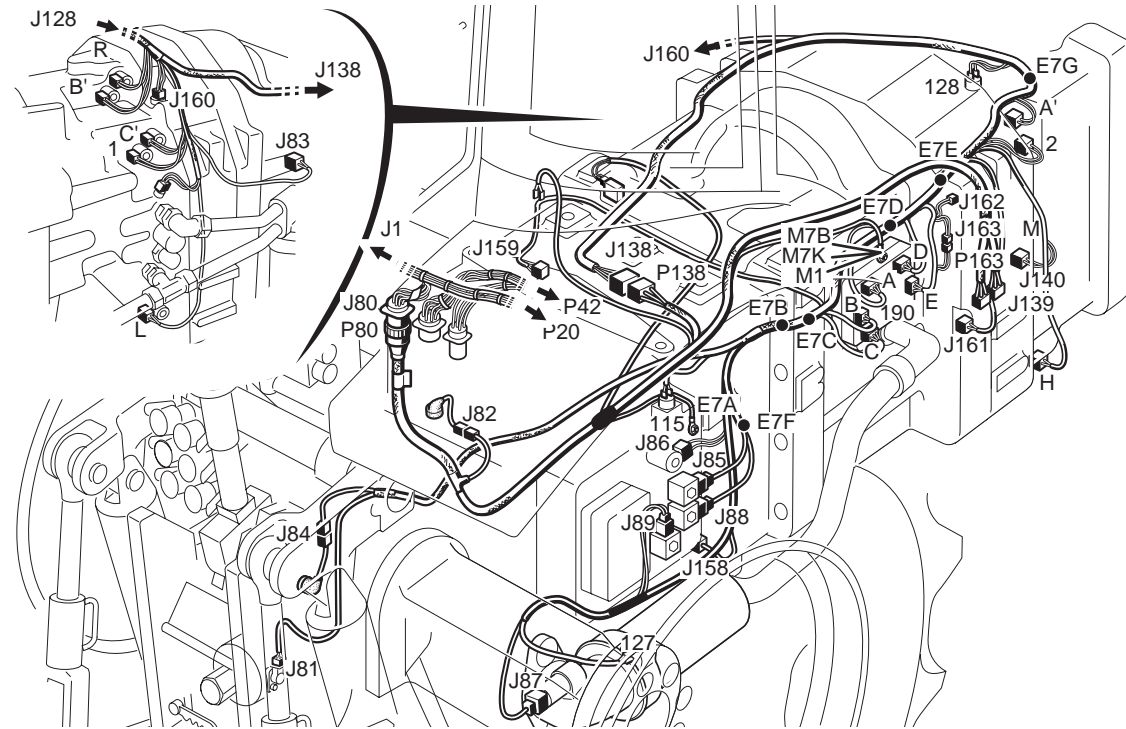

606hsm9J

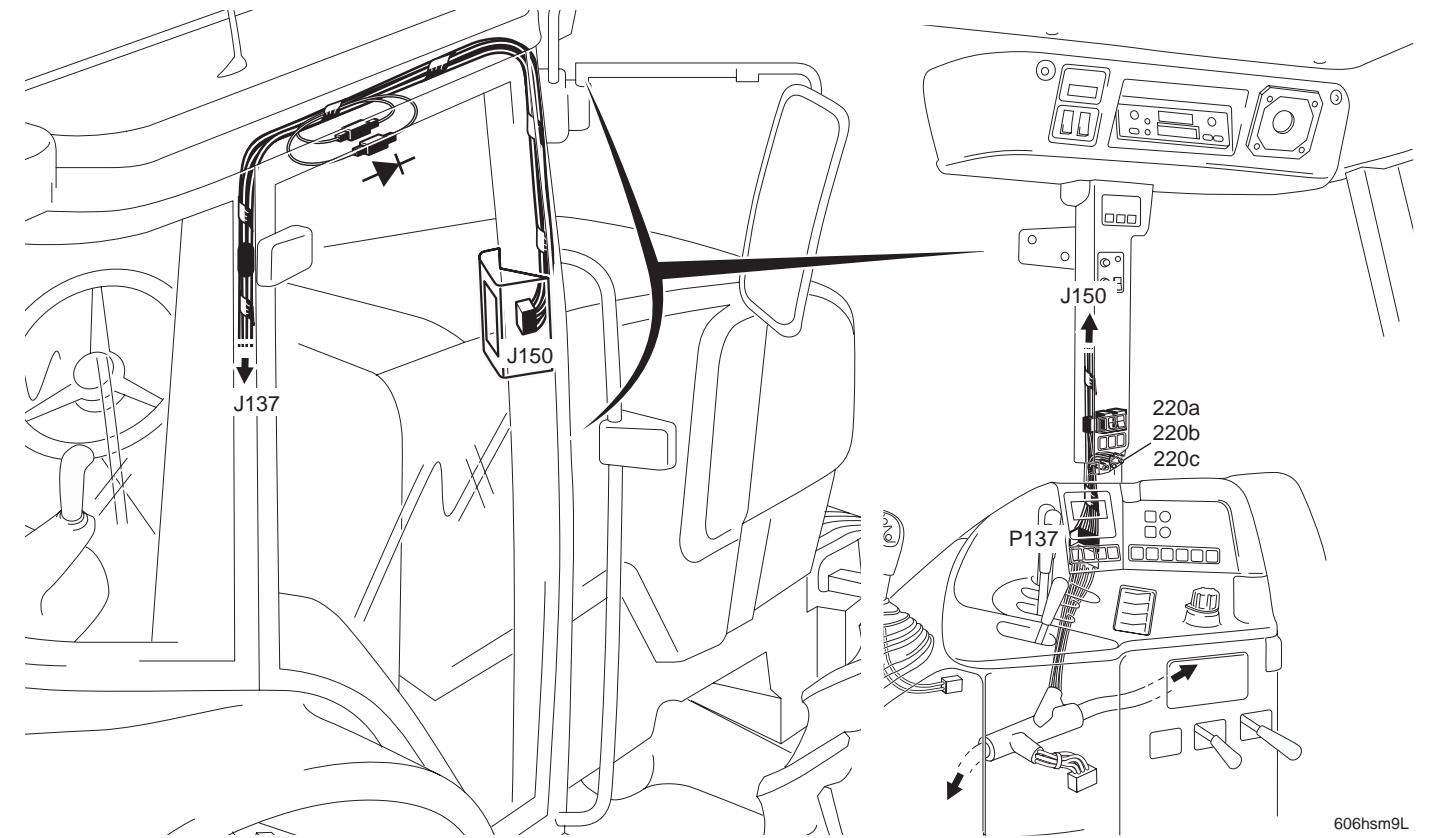

606hsm9L

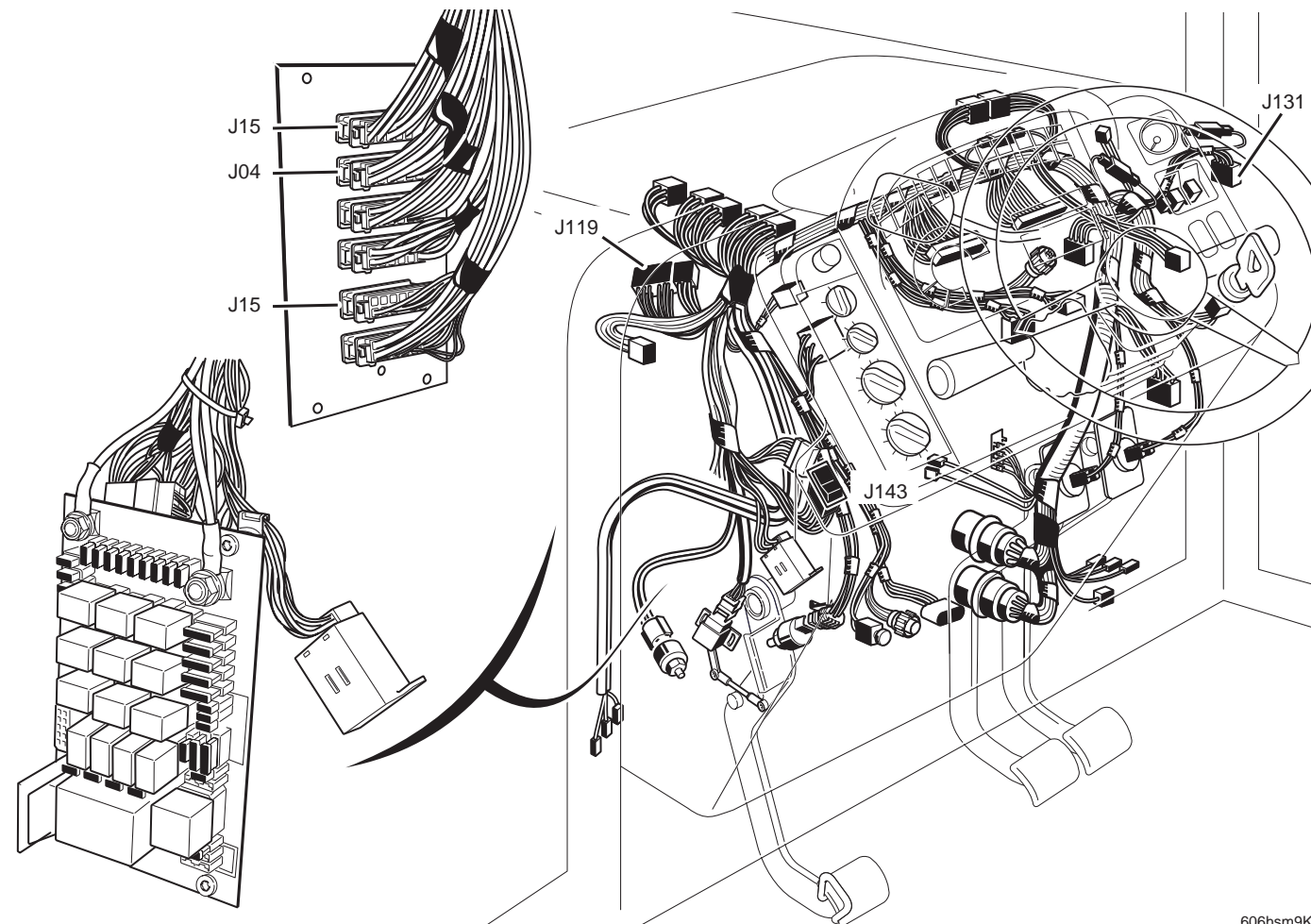

606hsm9K

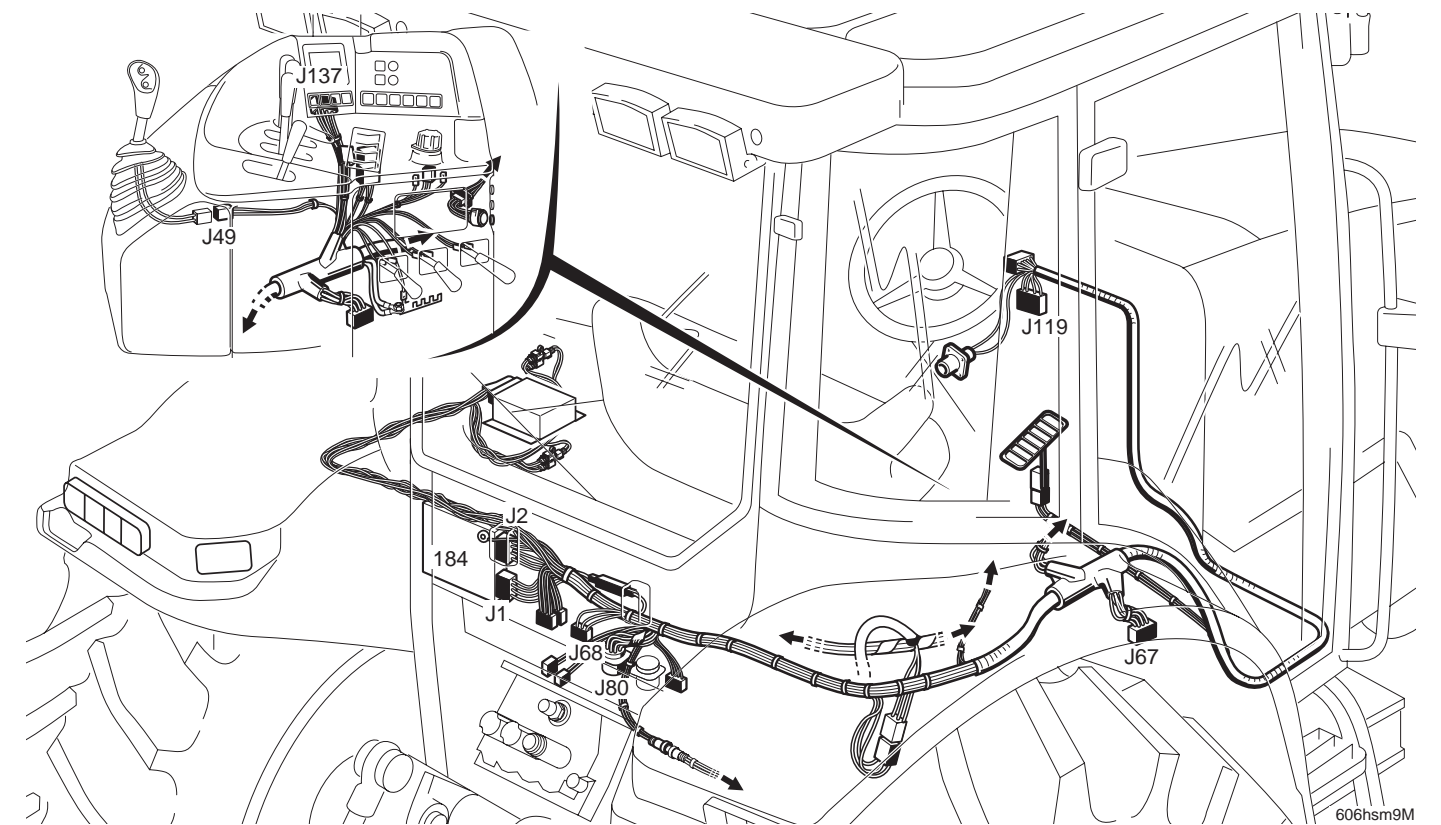

606hsm9M



Cross control

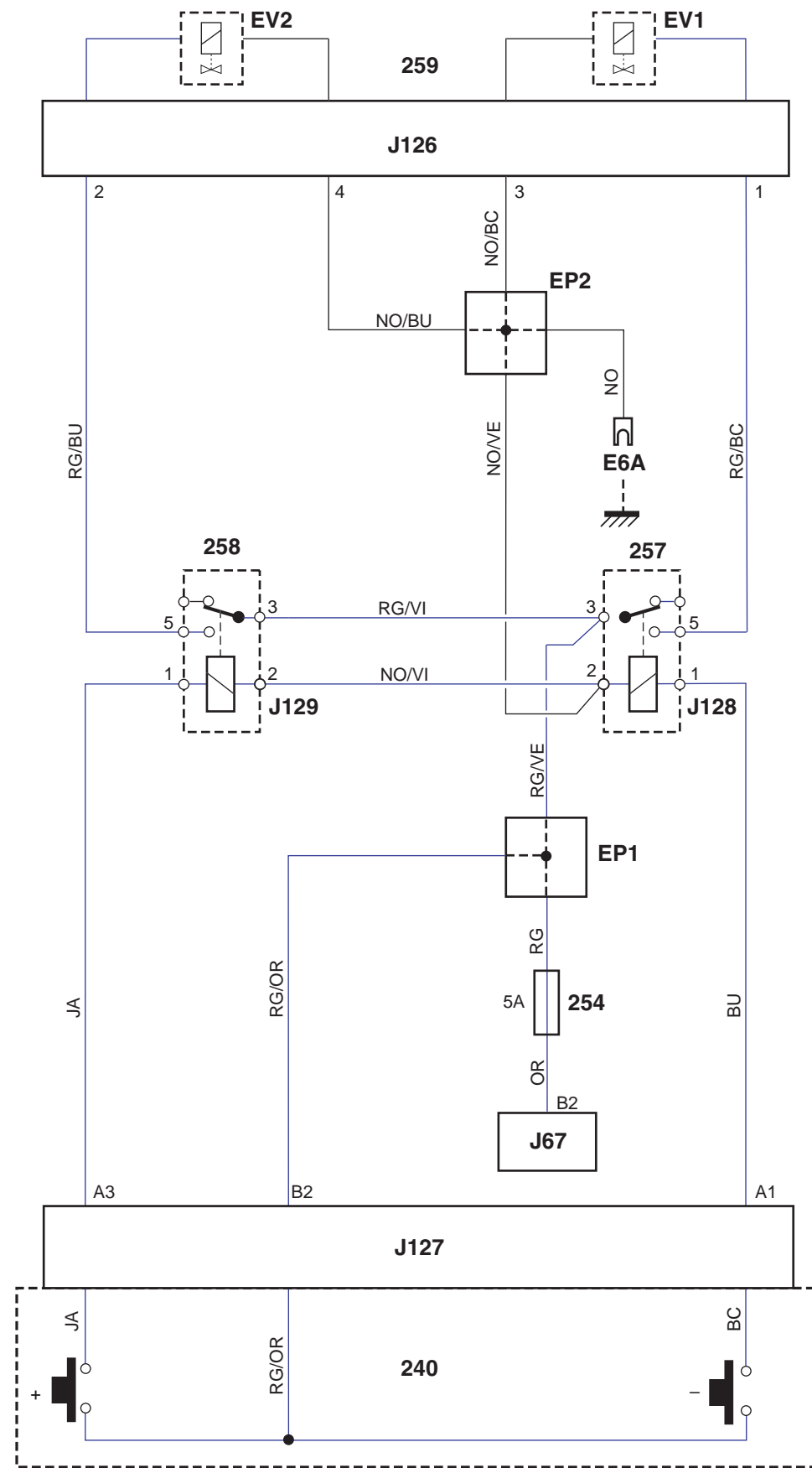

605hsm45

Ref	Item
240	Cross control
254	Front lift fuse
257	Front lift relay
258	Front lift relay
259	Front loader socket

Wire markers	2	J126	Ending
1	RD/WH	1	+ Solenoid valve A
2	RD/BL	1	+ Solenoid valve B
3	BK/WH	1	Solenoid valve A
4	BK/BL	1	Solenoid valve B
			J128 5
			J129 5
			EP2
			EP2

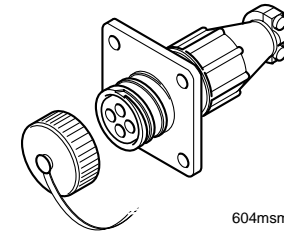
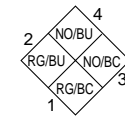

604msm1S

Wire markers	2	J127	Ending
A1	BL	1	A relay control
A3	YL	1	B relay control
B2	RD/OR	1	+APC cross control
			J128 1
			J129 1
			EP1
			EP1

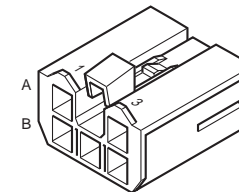
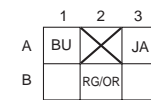

604msm2S

Wire markers	2	J128	Ending
1	BL	1	A relay control
2	BK/GN	1	Relay A earth
2	BK/VI	1	Relay B earth
3	RD/VI	1	+APC
3	RD/GN	1	+APC
5	RD/WH	1	+ Solenoid valve A
			J127 A1
			EP2
			J129 2
			J129 3
			EP1
			J126 1

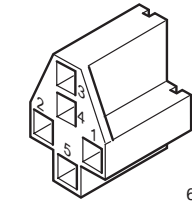
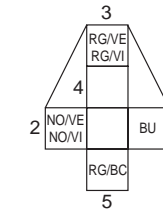

604msm3S

Wire markers	2	J129	Ending
1	YL	1	B relay control
2	BK/VI	1	Relay B earth
3	RD/VI	1	+APC
5	RD/BL	1	+ Solenoid valve B
			J127 A3
			J128 2
			J128 3
			J126 2

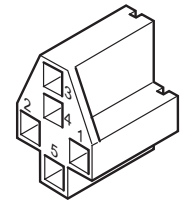
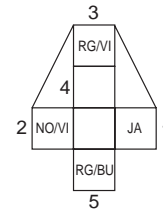

604msm4S

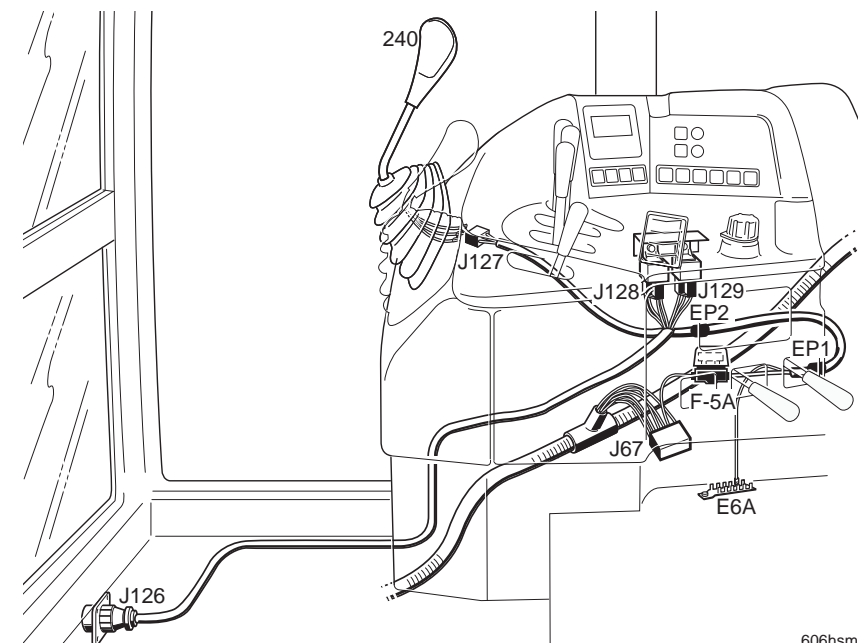

606hsm6F



1 - Instrument panel harness

Wire markers	2	J246	Ending
1	100	+APC implement socket	J03 9
2	085	Line L	P14 A
2	065	Diagnostic (L)	JX1 11
3	084	Line K	P14 C
3	066	Diagnostic (K)	JX1 12
4	—	—	—
5	—	—	—
6	—	—	—
7	—	—	—
8	—	—	—
9	080	Buzzer	J114 9
10	—	—	—
11	105	CAN - return	JX2 7
12	104	CAN + return	JX2 6
13	071	Radar speed	JX2 24
14	067	CAN -	JX1 13
15	068	CAN +	JX1 14
16	059	Handbrake	JX2 5
17	041	RH RR flashing light	J10 B6
18	037	LH rear flashing light	J10 B5
19	132	Rear stop	J248 12
20	116	RH rear light	J05 7
21	115	LH rear light	J114 6

	4	7	10	13	16	19
1	100			071	059	132
2	065			105	067	041
3	066			080	104	068
	084				037	115
		6	9	12	15	18
						21

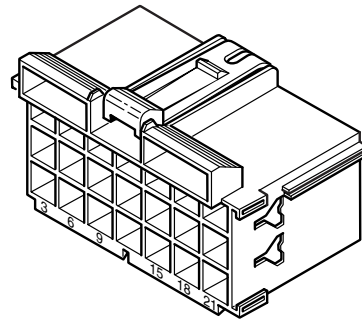

604hsm25

Wire markers	2	J247	Ending
1	094	+ APC rear window wiper	J04 7
2	128	Rear work light controls	J248 2
3	049	Windscr. wiper eng. park. pos.	J11 4
4	048	First speed windscreen wiper controls	J06 B1
5	137	+ Cab top lights	J09 A6
6	093	Rotating beacon control	J23 5
7	130	+ Parking clock/radio	J03 3
8	141	Temperature potent. cursor	J50 1
9	182	Rear windscreen washer pump	J02 S
10	140	Cab top potentiometer cursor	J12 A1
11	138	Cab top potentiometer	J12 A2
12	142	Temperature potentiometer	J50 2
13	144	Air conditioning thermostat	J03 6
14	145	Air condit. pressure switch	J02 N
15	—	—	—
16	—	—	—
17	—	—	—
18	—	—	—
19	095	+ AVC rear low work lights	J05 10
20	—	—	—
21	—	—	—

	4	7	10	13	16	19
1	094	048	130	140	144	095
2	128	137	141	138	145	
3	049	093	182	142		
		6	9	12	15	18
						21

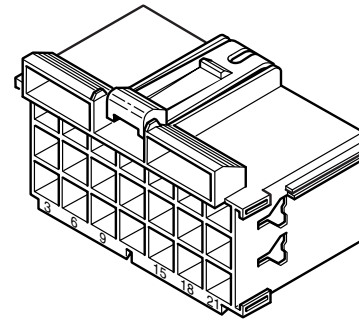

604hsm28

Wire markers	2	J248	Ending
1	127	+ APC outside rear work lights	J52 3
2	128	Rear work lights controls	J247 2
3	134	+ AVC inside rear work lights	J52 9
4	—	—	—
5	157	Not neutral	J130 1
5	156	Reverser relay ctrl engaged	J59 B4
6	M0S	Shuttle reverser	EOA
7	099	+ APC IP/utilities indicators	J09 A3
8	107	Reverser engaged	JX2 19
9	046	+APC wiper control	J06 A1
10	027	Rear stop	203
11	047	+APC windscreen wiper timer	J11 5
12	132	Rear stop	J246 19

	11	9	7	5	3	1
	047	046	099	157	134	127
				156		
	132	027	107	M0S		128
		12	10	8	6	4
						2

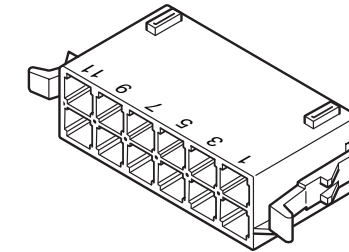

604hsm29

Wire markers	2	P01	Ending
R	003	+ AVC general	110
S	001	+ AVC general	J25 1
T	—	—	—
U	002	+ AVC general	110
V	012	Start-up	J114 2
W	017	Dipped light	J07 A4
X	018	Headlight	J07 A2
Y	—	—	—
Z	—	—	—

	S	T	U
	001		002
		R	
Z		003	012
			V
		018	017
	Y	X	W

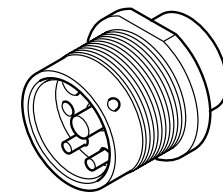

604msm47

Wire markers	2	P08	Ending
A1	136	Brake fluid level	JX1 10
A2	109	W alternator	JX2 21
A3	—	—	—
A4	110	Engine water temperature	JX2 17
A5	111	Air filter blocked	JX1 4
B1	106	Engine oil pressure	JX1 7
B2	007*	Preheating indicator	JX1 3
B3	M0T	Engine water temperature	JX2 2
B4	—	—	—
B5	—	—	—

* VP44 engine only

	1	2	3	4	5
A	136	109	X	110	111
B	106	007	M0T		

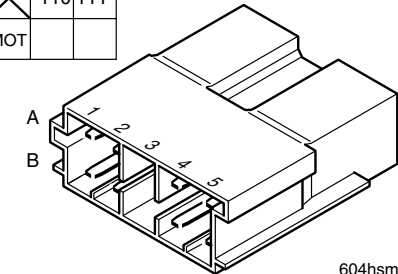

604hsm26

Wire markers	2	P14	Ending
A	085	Line L	J246 2
B	M0D	Diagnostic socket earth	J13 A2
C	084	Line K	J246 3
D	076	+APC diagnostic socket	J09 A1

	A	B	C	D
	085	M0D	084	076

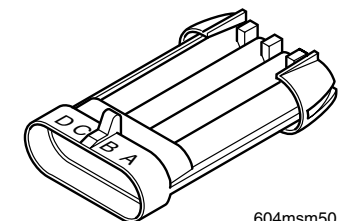

604msm50



4/2 - Front axle suspension control harness

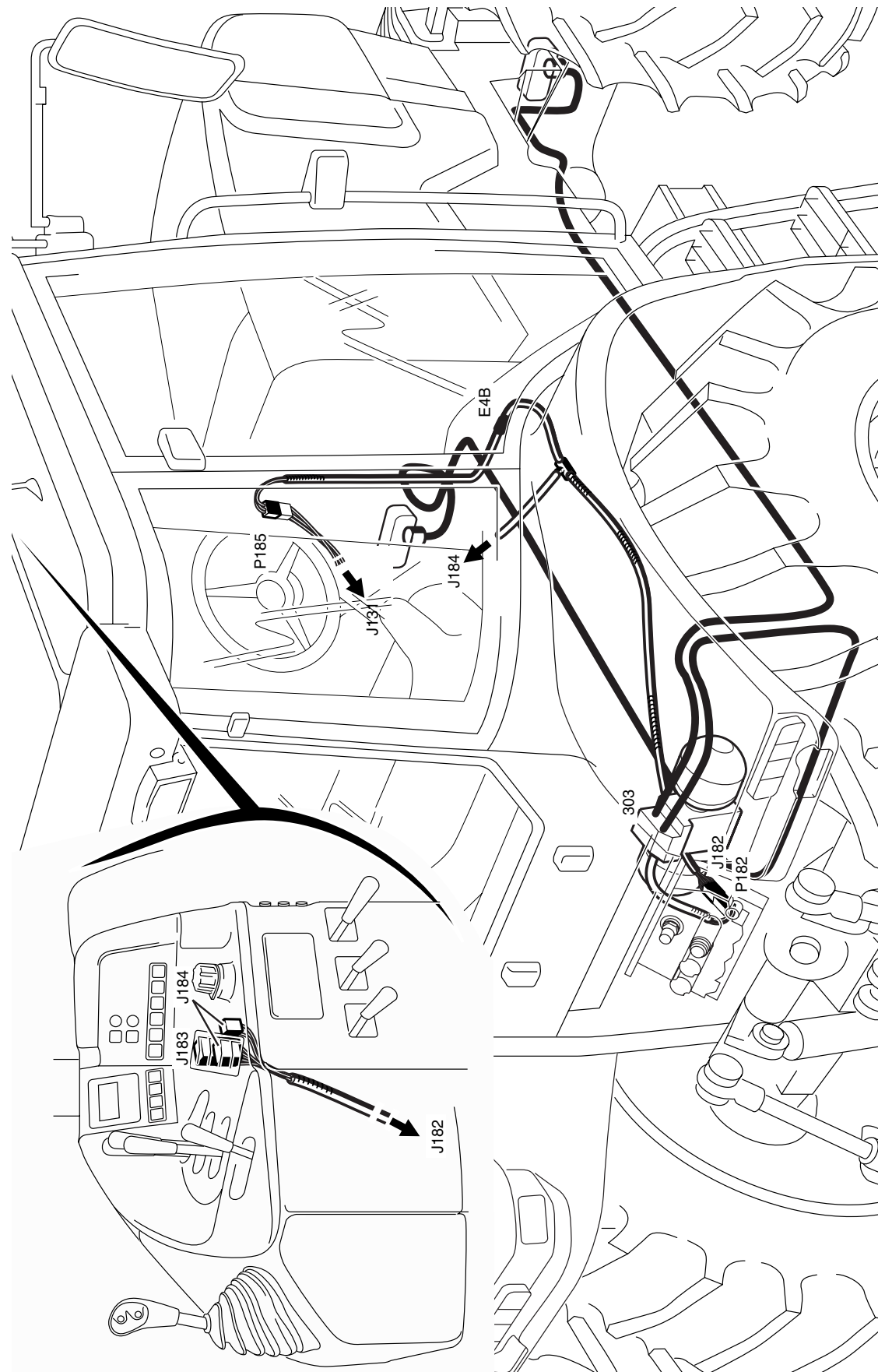

606msm06

Connectors	Designation
J182	Suspension control unit
J183	Suspension switch (manual)
J184	Suspension switch (auto)
P185	Instrument panel harness connection



7b - Closed centre circuit transmission harness (100 litres)

Wire markers	Wire	2	J92	Ending	
				P80	21
1	721	0,75	EV 2 4PS Solenoid valve earth 2 4PS	E7B	
2	M7L	0,75			

1	2
721	M7L

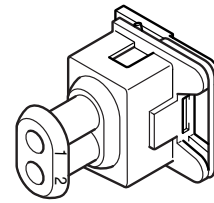

604msm5H

Wire markers	Wire	2	J93	Ending	
				P80	22
1	722	0,75	EV 1 4PS EV 1 4PS	E7B	
2	M7M	0,75			

1	2
722	M7M

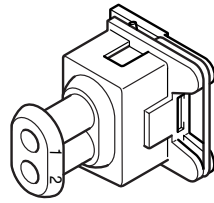

604msm6H

Wire markers	Wire	2	J94	Ending	
				P80	28
1	733	0,75	Park Lock ON solenoid valve Park Lock ON sol. valve earth	E7A	
2	M7D	0,75			

1	2
733	M7D

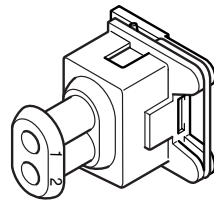

604hsm55

Wire markers	Wire	2	J95	Ending	
				P80	16
1	732	0,75	Park Lock OFF solenoid valve Park Lock OFF sol. valve earth	E7A	
2	M7S	0,75			

1	2
732	M7S

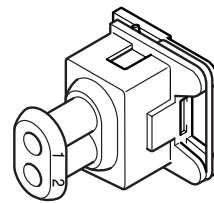

604hsm56

Wire markers	Wire	2	J116	Ending	
				P80	26
1	726	0,75	Forward drive solenoid valve Forward drive - SV return	P80	10
2	710	0,75			

A	B
726	710

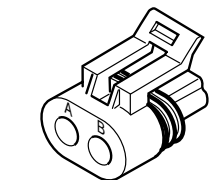

604msm7H

Wire markers	Wire	2	J117	Ending	
				P80	27
1	727	0,75	Reverse drive solenoid valve Reverse drive - SV return	P80	30
2	730	0,75			

A	B
727	730

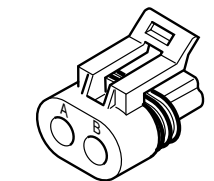

604msm8H

Wire markers	Wire	2	J132	Ending	
				P80	24
1	724	0,75	Solenoid valve shunt	P80	

A
724

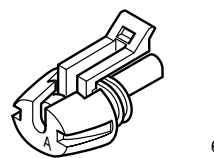

604msm9H

Wire markers	Wire	2	J139	Ending	
				P80	17
A	718	0,75	Steering angle signal + Steering angle - Steering angle	P80	37
B	728	0,75			
C	731	0,75			

C	B	A
731	728	718

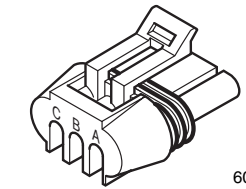

604hsm60

Wire markers	Wire	2	J145	Ending	
				P80	29
1	729	0,75	+ Module speed ISC Module speed ISC	E7C	
2	M7Q	0,75			

1	2
729	M7Q

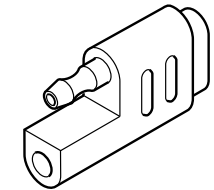

604msm0i

Wire markers	Wire	2	J149	Ending	
				P80	1
A	701	0,75	Range contact Range contact	P80	2
B	702	0,75			

1	2
702	717

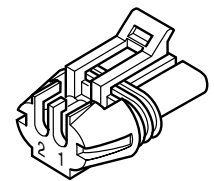

604hsm57

Wire markers	Wire	2	J150	Ending	
				P80	24
1	735	0,75	Park Lock OFF +APC	E7D	
2	715	0,75			

1	2
735	715

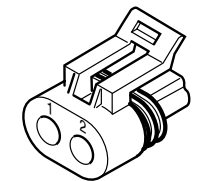

604hsm59

Wire markers	Wire	2	J151	Ending	
				P80	18
1	734	0,75	Park Lock use +APC	E7D	
2	716	0,75			

1	2
734	716

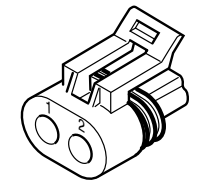

604hsm58

Wire markers	Wire	2	J202	Ending	
				P80	3
1	703	1	Hydraulic pressure Hydraulic pressure earth	E7A	
2	M7E	1			
3	—	—			
4	—	—			

1	2
703	M7E
3	4

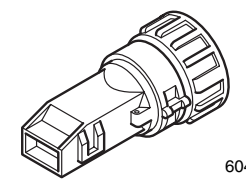

604msm3i



8a - GTA 103 / 202 - GPA 40 transmission control harness

8b - FPS transmission control harness

Wire identification	Wire identification	2	P119	Ending
1	M8I	0,6	Fuel level	J80 34
2	—	—	—	—
3	—	—	—	—
4	8034	0,6	Park lock control	J237 34
5	—	—	—	—
6	—	—	—	—
7	—	—	—	—
8	—	—	—	—
9	—	—	—	—
10	—	—	—	—
11	—	—	—	—
12	878	1,5	+APC solenoid valve supply	J2 33
13	883	0,6	Controls declutch ISC	J49 A1
14	855	1,5	+APC	J67 B2
15	839	1,5	+AVC DRIVETRONIC III	J2 27
15	8029	1	+AVC auto V	J237 29

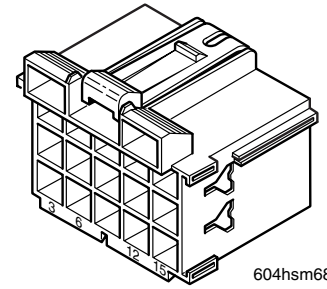
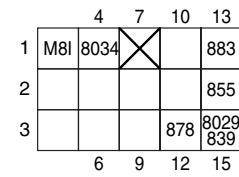

604hsm68

Wire identification	Wire identification	2	P133	Ending
1	881	0,6	CAN-Low (Instrument panel)	J231 1
2	880	0,6	CAN-High (Instrument panel)	J231 2
3	—	—	—	—
4	—	—	—	—

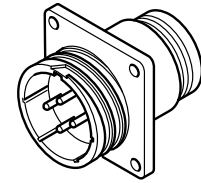
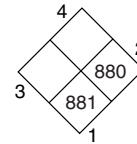

604hsm76

Wire identification	Wire identification	2	P189	Ending
1	8006	0,6	CAN-Low (TCE)	J232 1
2	8005	0,6	CAN-High (TCE)	J232 2
3	—	—	—	—
4	—	—	—	—

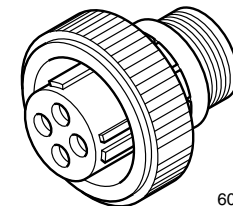
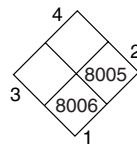

604hsm77

Wire identification	Wire identification	2	P999	Ending
1	8021	1	Air brake solenoid valve	J80 32
2	M8Q	1	Air brake solenoid valve earth	J80 35

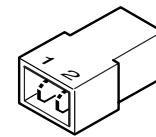
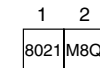

604msm7K

Wire identification	Wire identification	2	J1	Ending
1	867	0,75	Transmission display data	J137 B2
2	868	0,75	Transmission display clock	J137 B4
3	—	—	—	—
4	802	0,75	Park lock relay	P119 5
5	840	0,75	Transmission oil filter	P20 6
6	836	0,75	Transmission oil temperature	P20 11
7	—	—	—	—
8	815	0,75	Differential control	J46 1
9	837	0,75	+APC seat safety	J67 B7
10	830	0,75	+ Tractor speed sensor	J80 12
11	8023	0,6	+APC EVP	P119 12
12	882	0,75	CAN -	J188 A5
13	880	0,75	CAN-High	J188 A1
14	—	—	—	—
15	808*	0,75	Tractor speed	J136 B1
15	808	0,75	Rear PTO light	P20 15
16	M8J	1	Electronic unit earth	J68 B4
17	—	—	—	—
18	—	—	—	—
19	—	—	—	—
20	862	0,75	Buzzer (LED)	134
21	833	0,75	Hydraulic pressure	P20 4
22	804	0,75	Park lock light	P119 7
23	—	—	—	—
24	—	—	—	—
25	839	1,5	+AVC electronic unit	J119 15
26	813	1,5	+APC electronic unit	J67 A1
27	M8H	1	Electronic unit	J68 B6
28	805	0,75	Starting relay	P119 8
29	806	0,75	Gearbox engaged	P119 9
30	807	0,75	Rear PTO light	P20 15
31	—	—	—	—
32	—	—	—	—
33	—	—	—	—
34	829	0,75	Tractor speed sensor	J80 13
35	—	—	—	—
36	881	0,75	CAN-Low	J188 B7

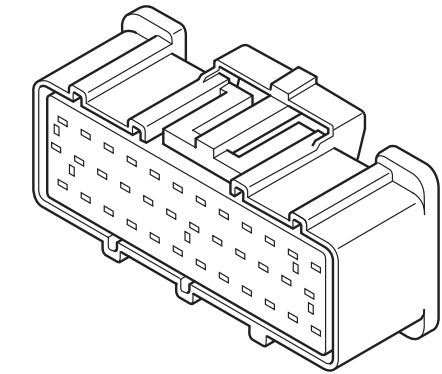
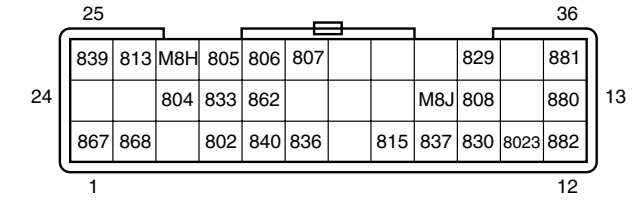

604hsm78

* Version without ISO socket only.



9b - TCE 15T Control harness

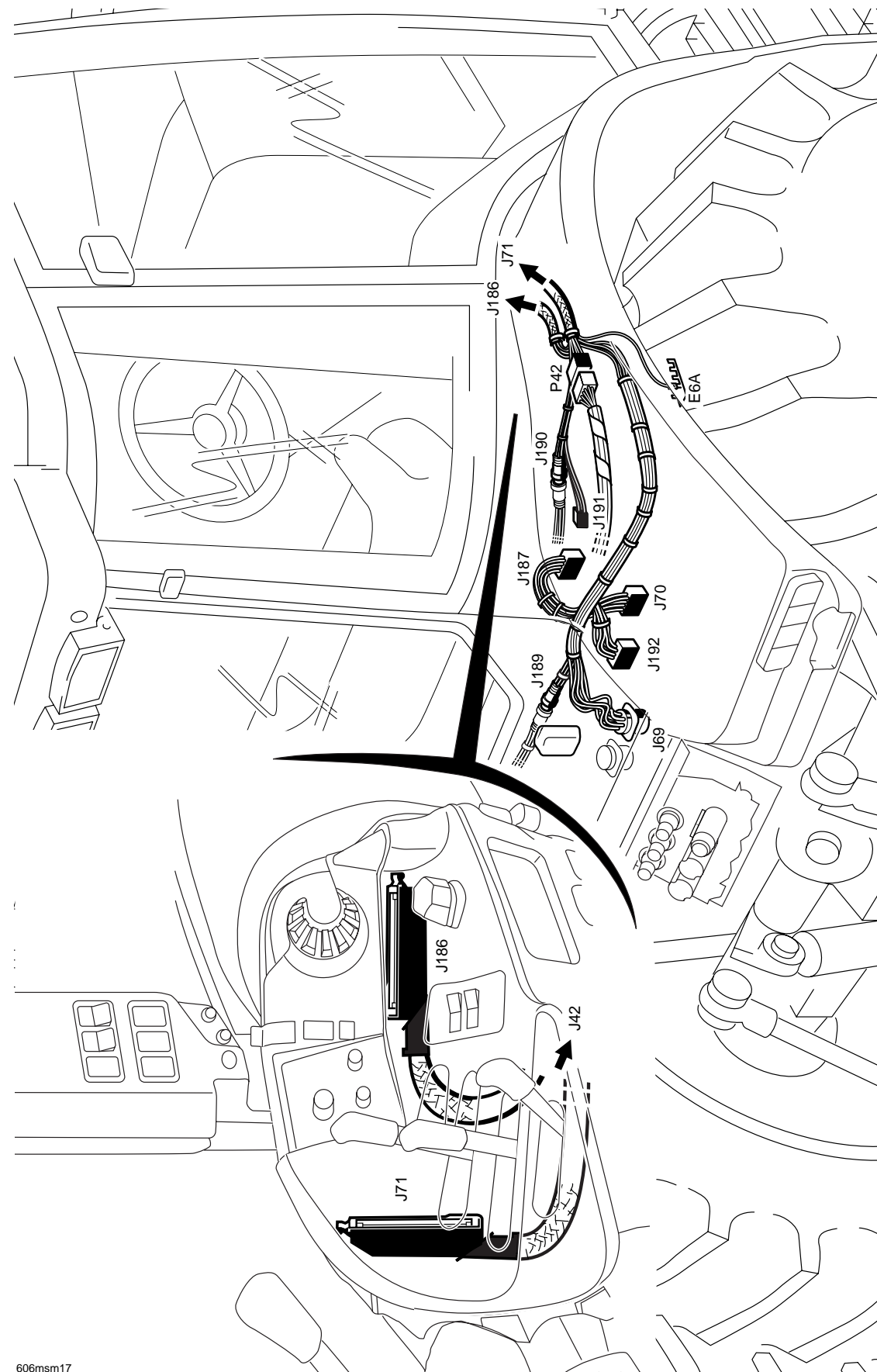

606msm17

9b - TCE 15T Control harness

Connectors	Designation
J69	TCE harness connection
J70	Shunt receptacle (grey)
J71	Electronic linkage control unit (TCE)
J186	Lift central unit (TCE)
J187	Shunt receptacle (grey)
J189	Transmission control harness connection
J190*	Electrohydraulic spool valve (DEH) control harness connection
J191*	Electrohydraulic spool valve (DEH) control harness connection
J192*	Shunt receptacle (white)
P42	Rear harness connection

* Version with electrohydraulic spool valves



9/2a - Cross control harness with Electropilot

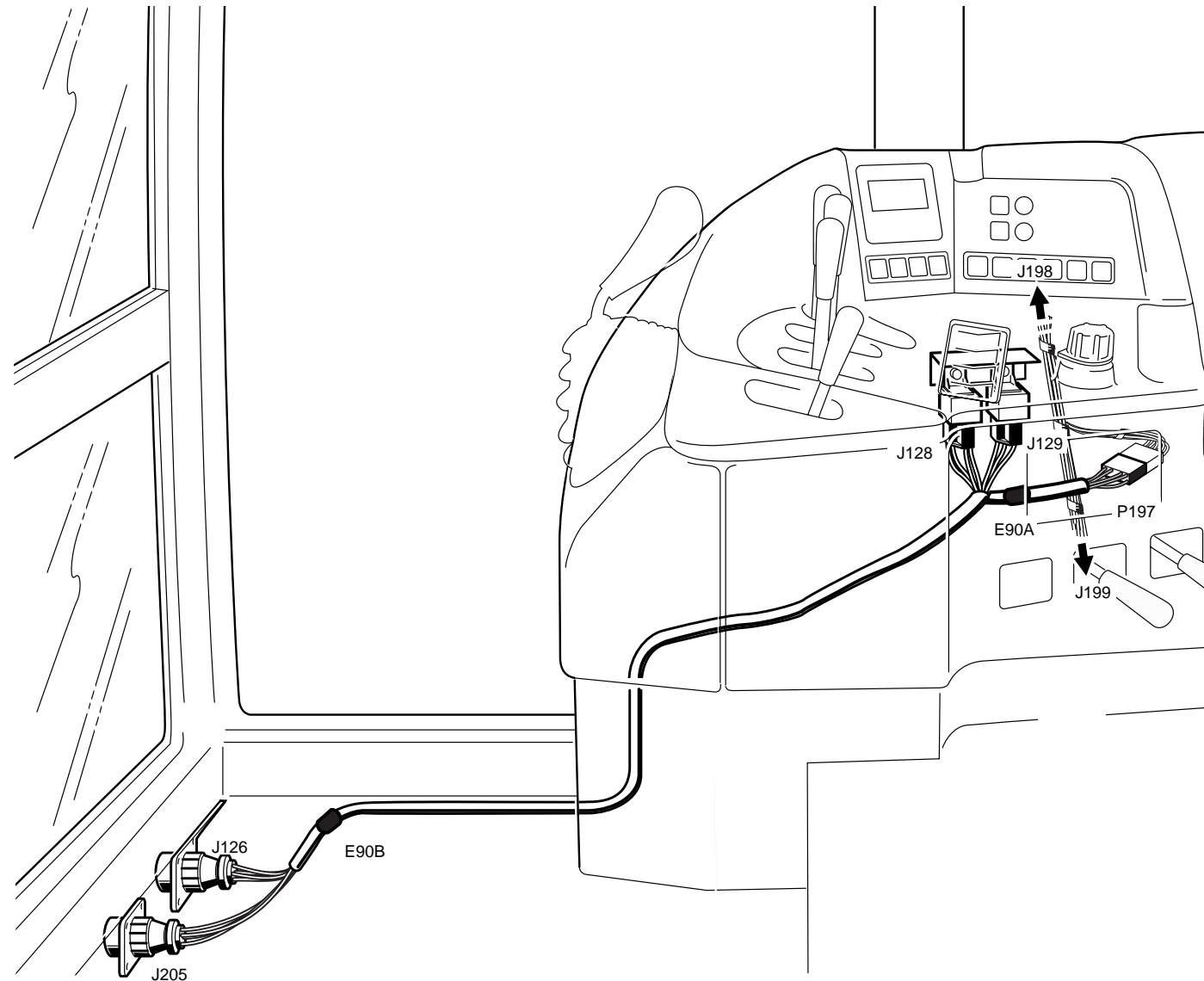

606msm19

Connectors	Designation
J126	Front loader socket
J128	A solenoid valve relay
J129	B solenoid valve relay
J205	Front lift socket
P197	Electrohydraulic spool valve (DEH) control harness connection

9/2b - Cross control harness

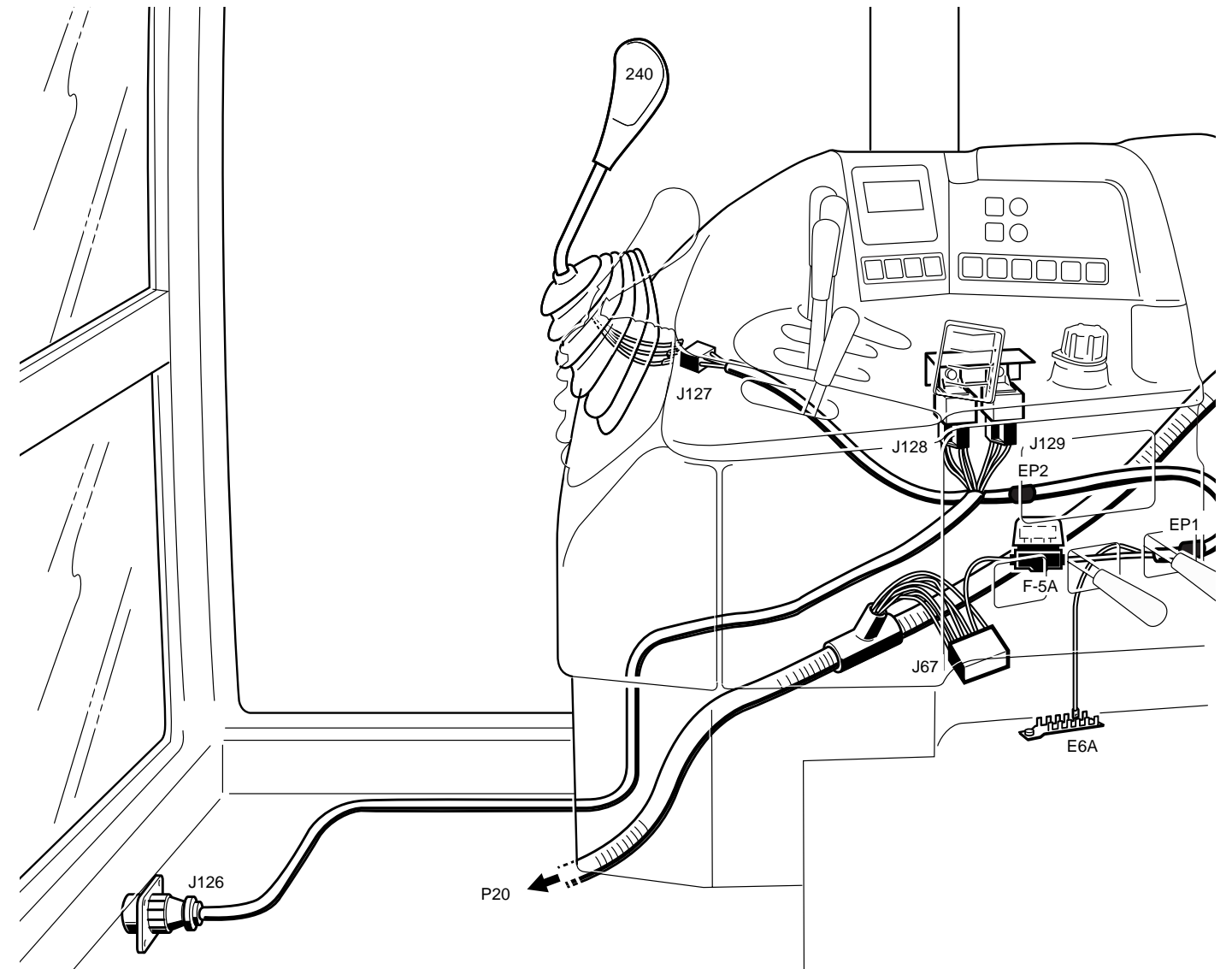

i06msm20

Connectors	Designation
J126	Front loader and lift socket
J127	Control connection
J128	A solenoid valve relay
J129	B solenoid valve relay



G1 – INSTRUMENT PANEL

Characteristics

Inputs/outputs relating to red lights

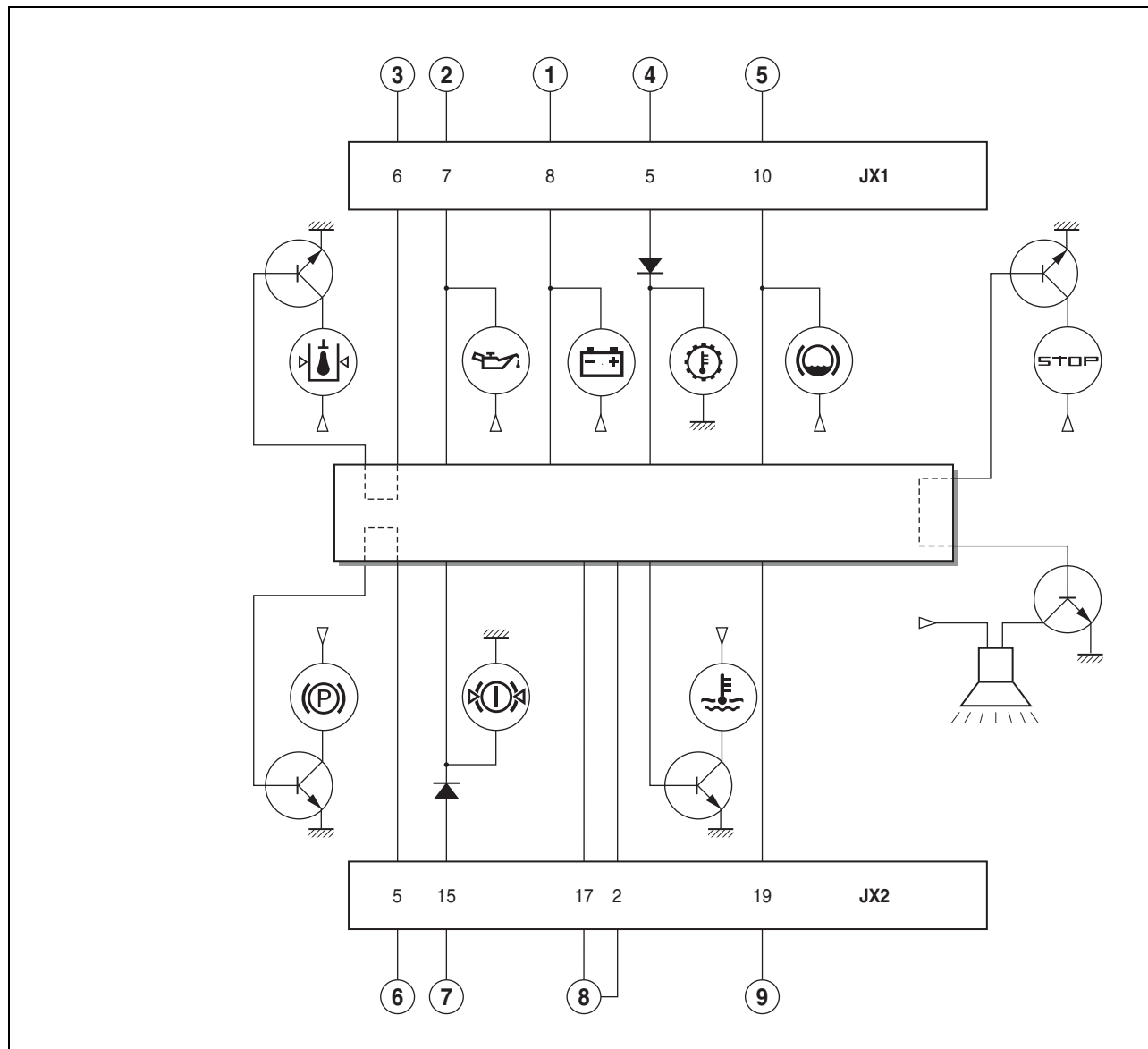

584hsm23

Fig. 17

Parts list

- | | |
|-------------------------------------|---------------------------------------|
| 1 Alternator regulator, charge D+. | 6 Parking brake switch. |
| 2 Engine oil pressure switch. | 7 Not used. |
| 3 Transmission oil pressure switch. | 8 Engine temperature thermistor. |
| 4 Transmission oil temperature. | 9 Gearbox engaged. |
| 5 Brake fluid level switch. | 10 Dashboard electronic control unit. |

Nature of the signal or electrical level when lit

- 1 : Voltage below 12 V.
- 2, 3, 5, 6 : Earthing.
- 4, 7 : 12 V.
- 8 : 106 ohm.
- 9 : Earth .

Description

Access to the installed software version (TCE 15 or TCE 25)

To obtain the information:

- Switch on the ignition.
- Press keys (3) simultaneously.

The software will be divided into 2 stages. e.g. 0/12. The display scrolls between these two digits constantly.

Lift operating conditions

If the safety warning light is lit when the tractor is started up, several actions must be carried out to reset the lift.

- Move the switch (1) to the "working" position then, immediately afterwards, to the "stop" position.
- Wait for 2 seconds for the CPU to unlock.



382hsm01

Fig. 2

Error codes

System faults appear as an error code. This is indicated on the screen by "ER" and the code number.

CC = short circuit - CO = circuit open

N.B.: To diagnose the fault corresponding to the error code, use Win Métiadiag© and consult chapter "G7" (lift application).

Checks and adjustments

Radar (TCE 25 only)

The radar is mounted on the right-hand side of the transmission.

Important: Do not look directly at the transducer to avoid eye damage from the microwaves emitted by this radar when connected.

N.B.: See chapter "F" to check the radar electrical power supply.

Lift spool valve solenoid valves

The solenoid valve resistance of the lift spool valve (A) is 1,8 ohm.

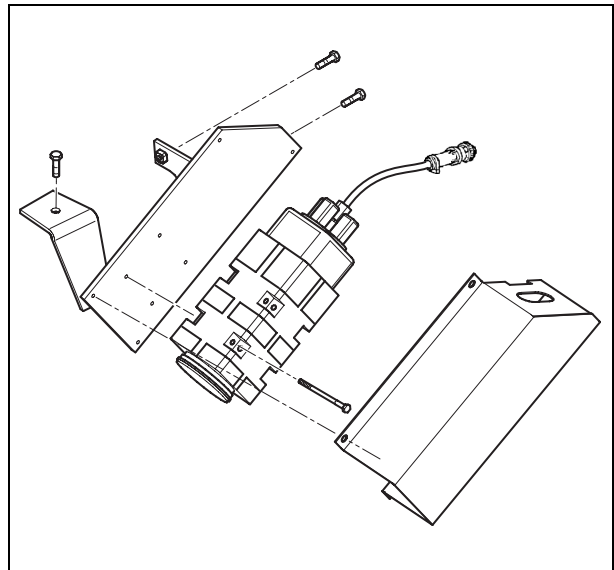

382hsm19

Fig. 22

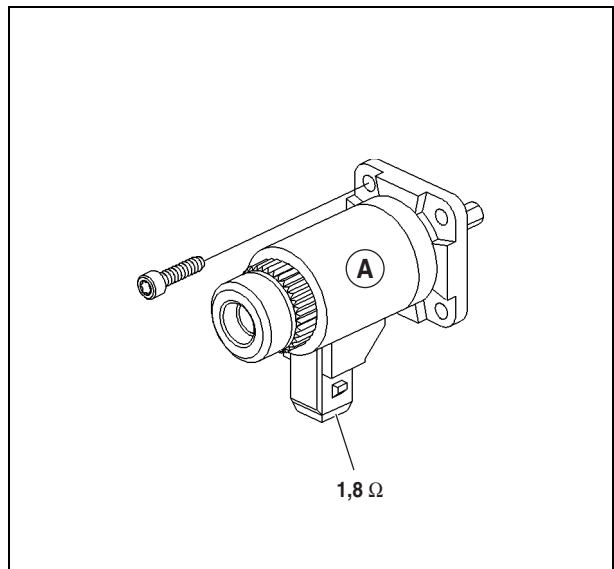

382hsm20

Fig. 23

Drivetronic III

Control pressure switch

- Operating pressure = maximum 30 bar.
- Engine off (0 bar), contacts "1", "2" open.
- Engine running (17 bar), contacts "1", "2" closed.
- If pressure drops, contacts "1", "2" open.

Lubrication/boost pressure switch, 3 bar (Fig. 11)

- Operating pressure = maximum 30 bar.
- Engine off (0 bar), contacts "1", "2" closed.
- Engine running (3 bar), contacts "1", "2" open.
- If pressure drops, contacts "1", "2" closed.

Blockage indicator (Fig. 12)

- Mounted in parallel to the filter, if " ΔP " between chambers "A" and "B" greater than or equal to 2,4 bar

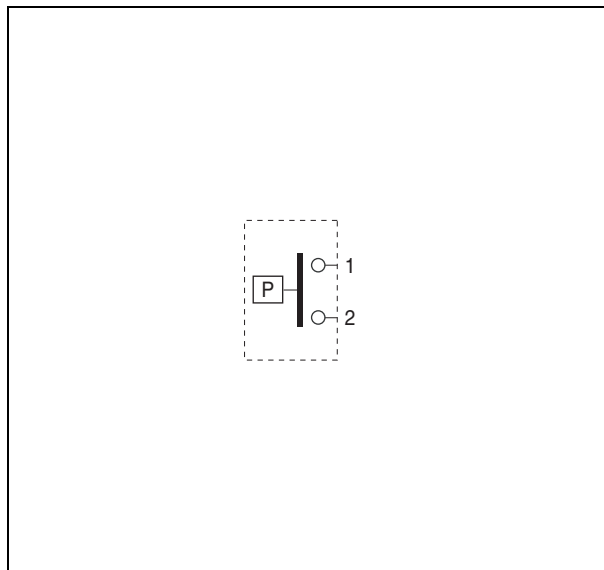

583hsm27

Fig. 10

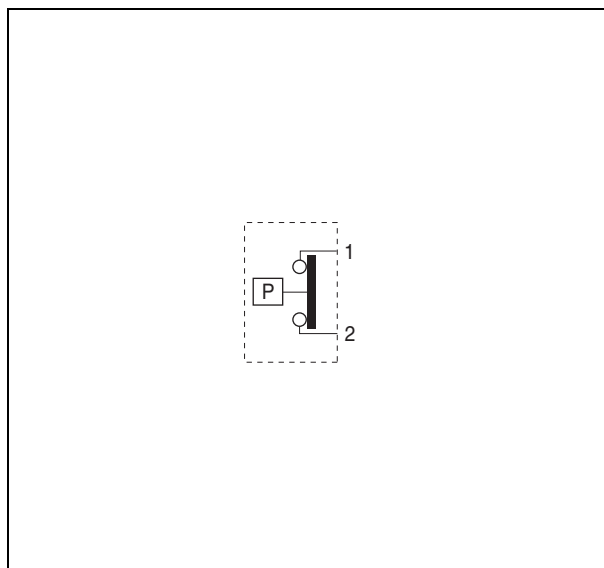

583hsm28

Fig. 11

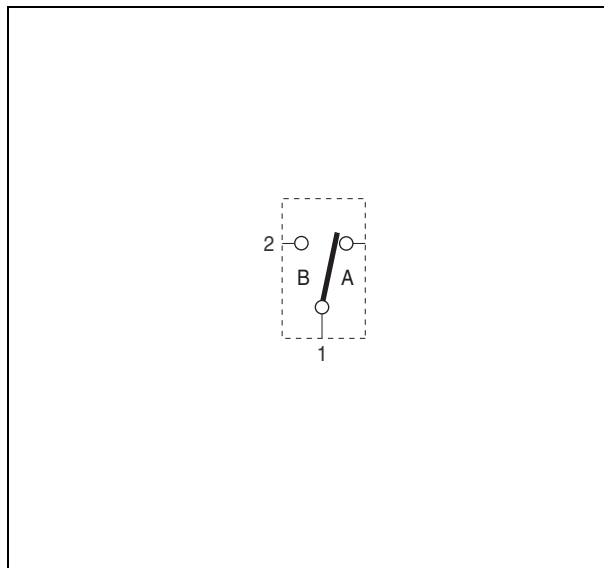

583hsm29

Fig. 12



Drivetronic III

Maximum engine speed setpoints in road range for tractors limited to 40 km/h.

Tractor type	III – 4	IV – 1	IV – 2	IV – 3	IV – 4
Ares 816 (plate shaft)	—	—	—	2 100	1 840
Ares 816 (smooth shaft) 826/836 (30 km/h)	—	—	—	2 200	1 990
Ares 836 (40 km/h gearbox)	—	—	—	—	—

- Excessively low temperature control (only on activation)

If temperature < 0°C: Indicators "1" and "4" flash simultaneously.

If forward speed > maximum permitted speed x (28/30): The engaged gear indicator flashes.

If forward speed > maximum permitted speed, the 4 indicators "1", "2", "3", "4" flash simultaneously.

If forward speed > maximum permitted speed x (33/30) and gear "3" selected: Downshift from "3" to "2".

If forward speed > maximum permitted speed x (32/30) and gear "4" selected: Downshift from "4" to "3".

- Oil pressure fault

Shifted to gear "4". When the fault is cleared, the function is activated.

- Engine speed fault

System frozen. When the fault is cleared, the function is activated.

- Battery voltage > 16 V

Shifted to gear "4" and indicator out. When the fault is cleared, the function is activated.

Use of tractor is downgraded mode

Defect on the tractor's forward speed sensor

Irrespective of the mechanical gear and the quadrupler gear engaged, the engine speed setpoint is 1 800 rpm for a tractor limited to 40 km/h. This fault is detected by the gearbox sensor in neutral and by the speed sensor measuring the speed of the ISC module.

- CAN fault

If the setpoint transmitted to the engine ECU by the transmission ECU is incorrect or if there is no setpoint, the engine speed is limited to 1 400 rpm. (Default value in engine ECU).

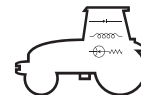

Drivetronic V

When the tractor is started up, the emergency brake attempts to engage which enables the working order of the system to be checked (built-in test on the two indicators which stay lit for 1 second after start-up). Then they indicate the emergency brake status.

Conditions	E1	E2	S1	S2	V1	V2	Emergency brake released	Emergency brake engaged
Engine cut out + forward speed < 1 km/h	0	1 For 3 s then 0.	0	0	—	—	0	1
Engine running, "Revershift" lever moved forward or back or "S3" pressed	1	0	1	0	—	—	1	0
If forward speed between 1 and 5 km/h and "Revershift lever in neutral, press "S3"	0	0	0	0	Flashes slowly (engagement request in memory).	—	0	1
If forward speed < 1 km/h and "Revershift lever in neutral	0	1 For 3 s then 0	0	0	Lit solid	—	0	1
If emergency brake requested and mechanism worn	0	1 For 3 s then 0	0	1	Lit solid	Lit solid	0	1

Any request made other than in neutral or at a speed of over 5 km/h is not accepted or memorised. When emergency brake engagement has been requested, the request is cancelled if:

- The speed goes back above 5 km/h.

or

- "S3" is pressed again.

or

- The lever is in forward or reverse gear.

The system is deactivated when the emergency brake is engaged, the ignition is switched off and "Drivetronic III" has not emitted a message over the CAN for 30 seconds.

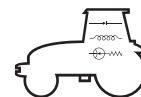

Full Powershift

Steering angle calibration

Transmission calibration

Turbo sensor calibration

PTO torque adjustment

Refer to chapter "G7".

Adjustment of TOC, BOC and angle detector switches

Refer to page G3.13.

DE 10 Pump

Engine coolant temperature sensor

Tightness torque = 10 N.m.

CTN type sensor.

Role: Informs the calculator of the amount of fuel to supply for starting up.

Determines the idling speed.

Engine protection.

Measurement of sensor resistance f (t°)	
16°C	: 4,2 kΩ ± 10%
60°C	: 134 Ω ± 10%
90°C	: 51,2 Ω ± 10%
100°C	: 38,5 Ω ± 10%

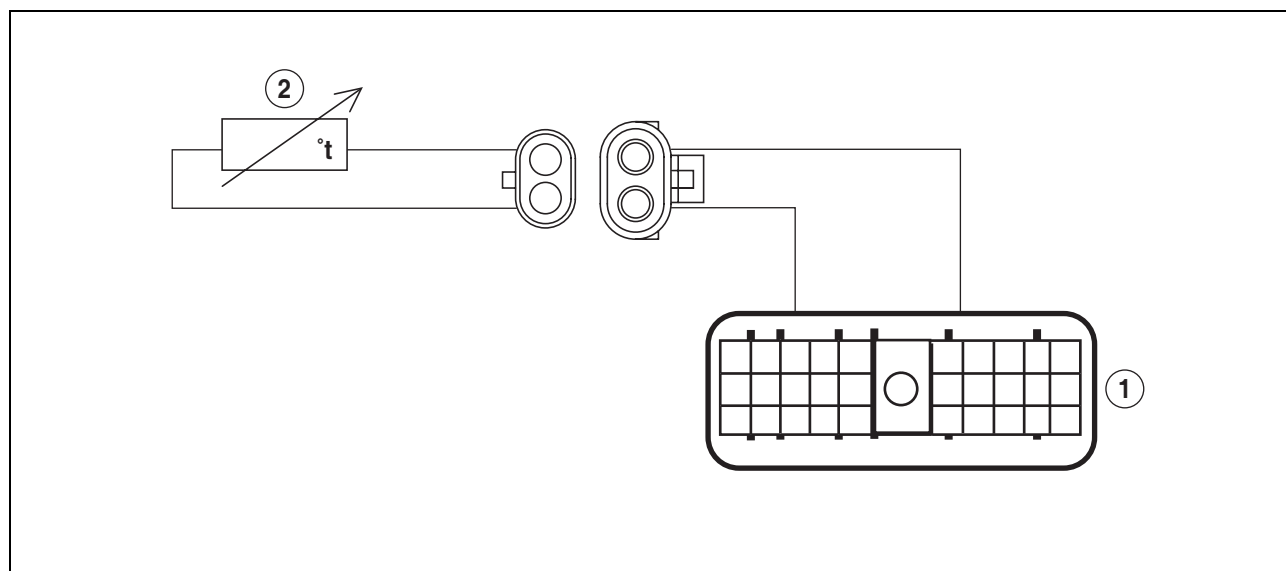

582msm04

Fig. 4

Parts list

- B1** Temperature input.
- D3** Sensor earth.

- 1** Engine control unit.
- 2** Engine coolant temperature sensor.

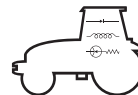

VP 44 Pump

Pump position sensor

Tightening torque = 1,4 daN.m.

Inductive type of sensor.

Resistance: 3 kΩ.

Frequency at 1 000 rpm = 280 Hz.

Role: Informs the ECU of the engine speed and the dead centre of each cylinder in order to supply the quantity of fuel to be injected at the appropriate time.

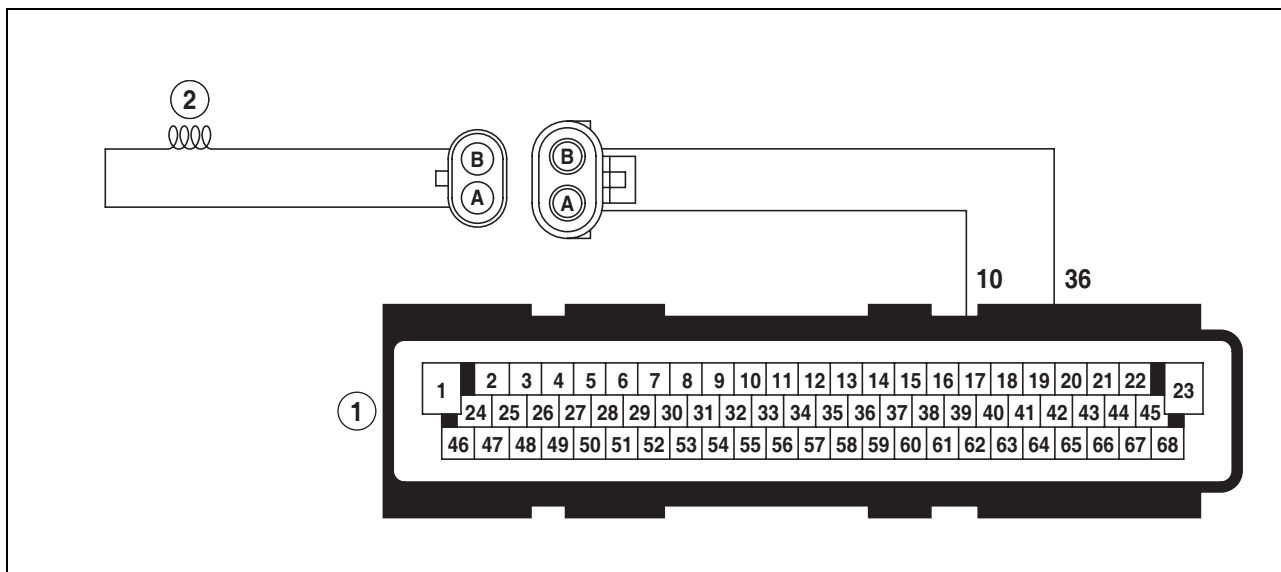

582hsm21

Fig. 16

Parts list

- | | |
|----------------------------------|--------------------------------|
| 1 Engine control unit connector. | 10 Pump position input signal. |
| 2 Pump position sensor. | 36 Pump position return. |

The pinion of the injection pump consists of 12 evenly spaced slots and an additional offset notch indicating the approach of the top dead centre of cylinder n° 1 to the engine control unit.



G5 – INFOTRAC AND ISO SOCKET

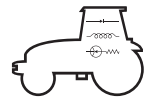

Removal/refitting and electrical checks

Forward speed calibration

Refer to the user manual.

Maintenance function

The computer must enable the technician to change the speed calibration parameters without running the calibration procedure, or to display the installed software version. The procedure to be carried out is as follows:

The user turns the unit on, by starting up the engine, at the same time holding down the function selection key for at least 4 seconds after turning the unit on.

- While the key is depressed all the segments are lit up.
- When the function menu key is released, all the segments on the display are lit for 3 seconds, then the indication "P1" appears for 3 seconds and the calibration parameter of the "theoretical speed" is displayed and becomes accessible.
- The calibration parameter of the theoretical speed flashes if its value is modified by pressing the +/- keys, the parameter is validated after a short press on the function selection key.
- A second short press on the function selection key enables you to go to the calibration parameter of the "real speed" after the display of the identification "P2" for 3 seconds, the real speed parameter is then displayed.
- The real speed calibration parameter flashes if its value is modified by pressing the +/- keys, the parameter is validated after a short press on the functions key.
- A third short press on the function selection key takes you to parameter "P3".

N.B.: Parameter available from units of references n° 77 000 63 688 and n° 77 000 70 600.

- Parameter "d – on" appears by pressing +/ "d – off" appears and flashes.
- "d – on" = configuration to operate with "D+" from the alternator.
- "d – off" = configuration to operate with an ignition source (+APC).
- A fourth short press on the function scroll key takes you to the "software version" display.
- If the function scroll key is held down for 4 seconds, then the onboard computer returns to the implement width function.



TOOLS

**Instrument panel – TCE 15/25 and TCE 15 T electronic lift –
Transmission/axle control – Engine management – Infotrac and
ISO socket – Electropilot**

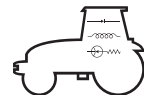

Engine application

SPN and FMI codes

The SPN FMI codes are codes in 3 parts in conformity with the standard SAE J1939.

The first part is the suspect parameter number (SPN). It generally contains 2 to 4 figures. The SPN identifies the affected system or component. For example: SPN 110 indicates a failure in the engine coolant temperature circuit.

The second part of the code is the failure mode identifier (FMI). The FMI contains 2 figures. The FMI identifies the type of failure produced. For example: FMI 3 indicates a value above the standard. For the failure to be precisely identified, the SPN and the FMI are both required. The combination of SPN 110 and FMI 3 signals a high engine coolant temperature input voltag.

The third part is the occurrence. It is the appearance number of the code concerned.

The engine control unit (UCE) transmits the SPN/FMI codes on the CAN network. This enables Win Métadiag[®] to display the active and memorised anomaly diagnostic codes. The following SPN FMI codes are classified in increasing order.

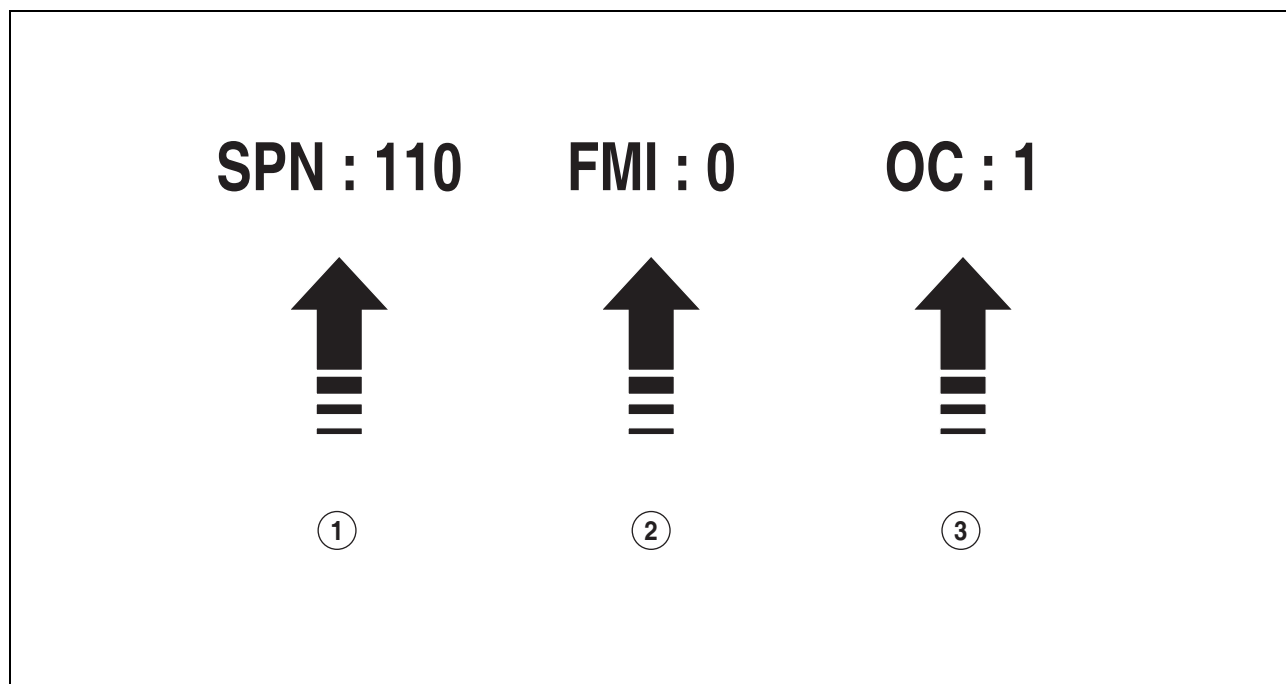

582msm13

Fig. 7

Parts list

1 System or component affected.

2 Type of failure.

3 Appearance number.

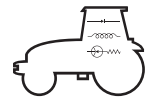

Engine application

Anomaly code SPN 174 FMI 4 Fuel temperature input voltage low

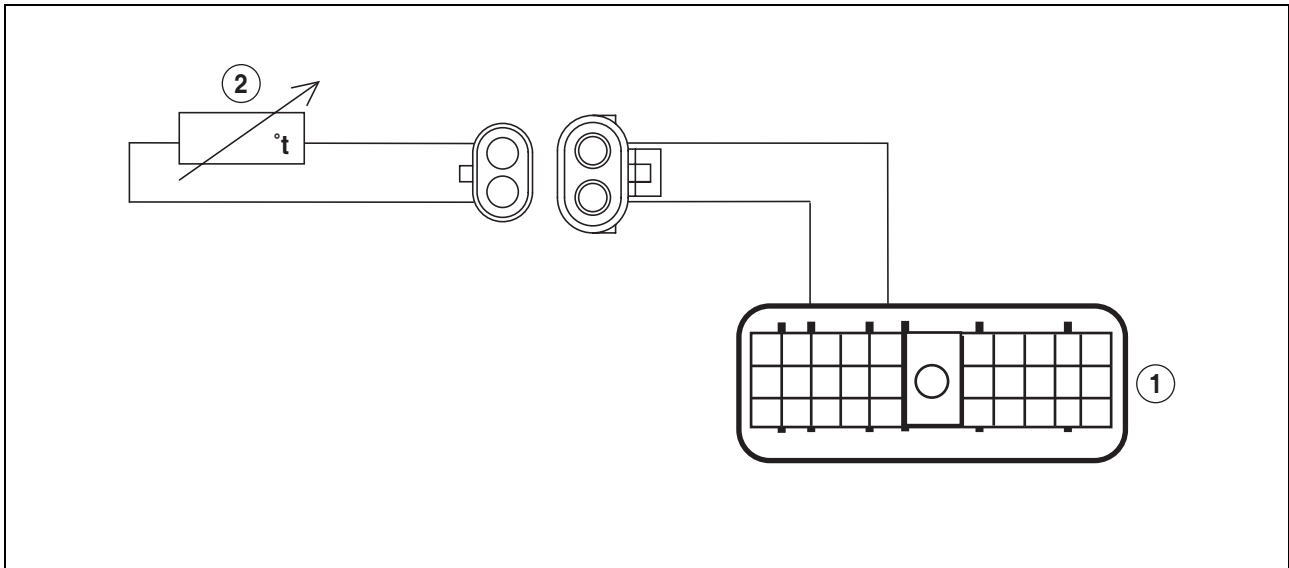

582msm05

Fig. 20

Parts list

C3 Fuel temperature input.
D3 Sensor earth.

1 Engine control unit.
2 Fuel temperature sensor.

Code SPN 174 FMI 4 is declared if

- The fuel temperature input voltage exceeds the sensor's maximum threshold. This voltage corresponds to a temperature lower than what is physically possible for the fuel.
- The maximum fuel temperature input voltage is 0,1 V.

This is what happens if the SPN 174 FMI 4 code is in force

- The engine control unit will use a default "return to workshop" value with a fuel temperature of -20 °C (-4 °F) during start-up and of 40 °C (104 °F) when running.
- The engine power is slightly reduced.

1. Check the connection

Carry out a preliminary inspection of the UCE unit, the collector air temperature sensor connection and all the connectors that link them up. Find any dirty, worn or badly positioned terminals.

No defective connection

Go to 2.

Defective connection(s)

Repair the defective connection(s).

2. Possible causes

- Short circuit at the earth at the sensor input.
- The temperature sensor is faulty.
- The engine control unit is defective.

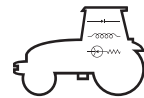

Engine application

Anomaly code SPN 1076 FMI 0 Pump distributor closure too long

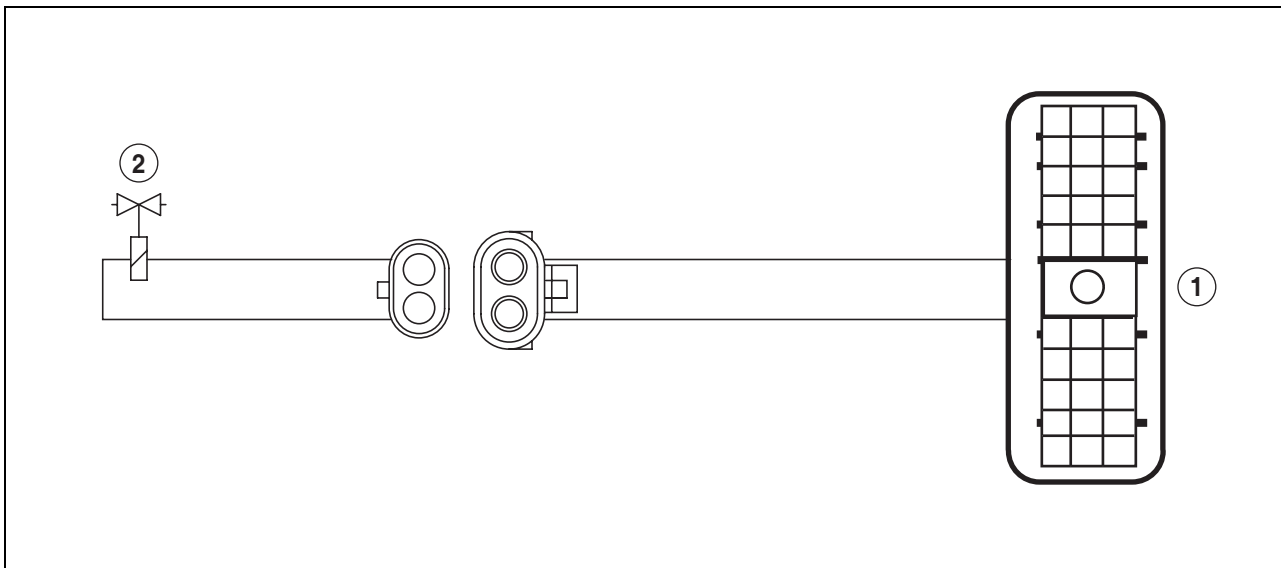

582msm20

Fig. 27

Parts list

- 1 Engine control unit.
- 2 Pump solenoid valve.

- A3 Pump solenoid valve return.
- K2 Pump solenoid valve feed.

Code SPN 1076 FMI 0 is declared if

The control unit determines that the pump distributor takes too long to close.

This is what happens if the SPN 1076 FMI 0 code is in force

The engine performances risk being irregular.

1. Check the connection

Carry out a preliminary inspection of the UCE unit connector, the pump connector and any other connector. Find any dirty, worn or badly positioned terminals.

No defective connection

Go to 2.

Defective connection(s)

Repair the defective connection(s).

2. Possible causes

- Pump distributor defective.
- The control unit is faulty.

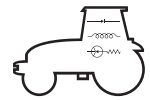

Engine application

Anomaly code SPN 91 FMI 3 High accelerator input voltage (C)

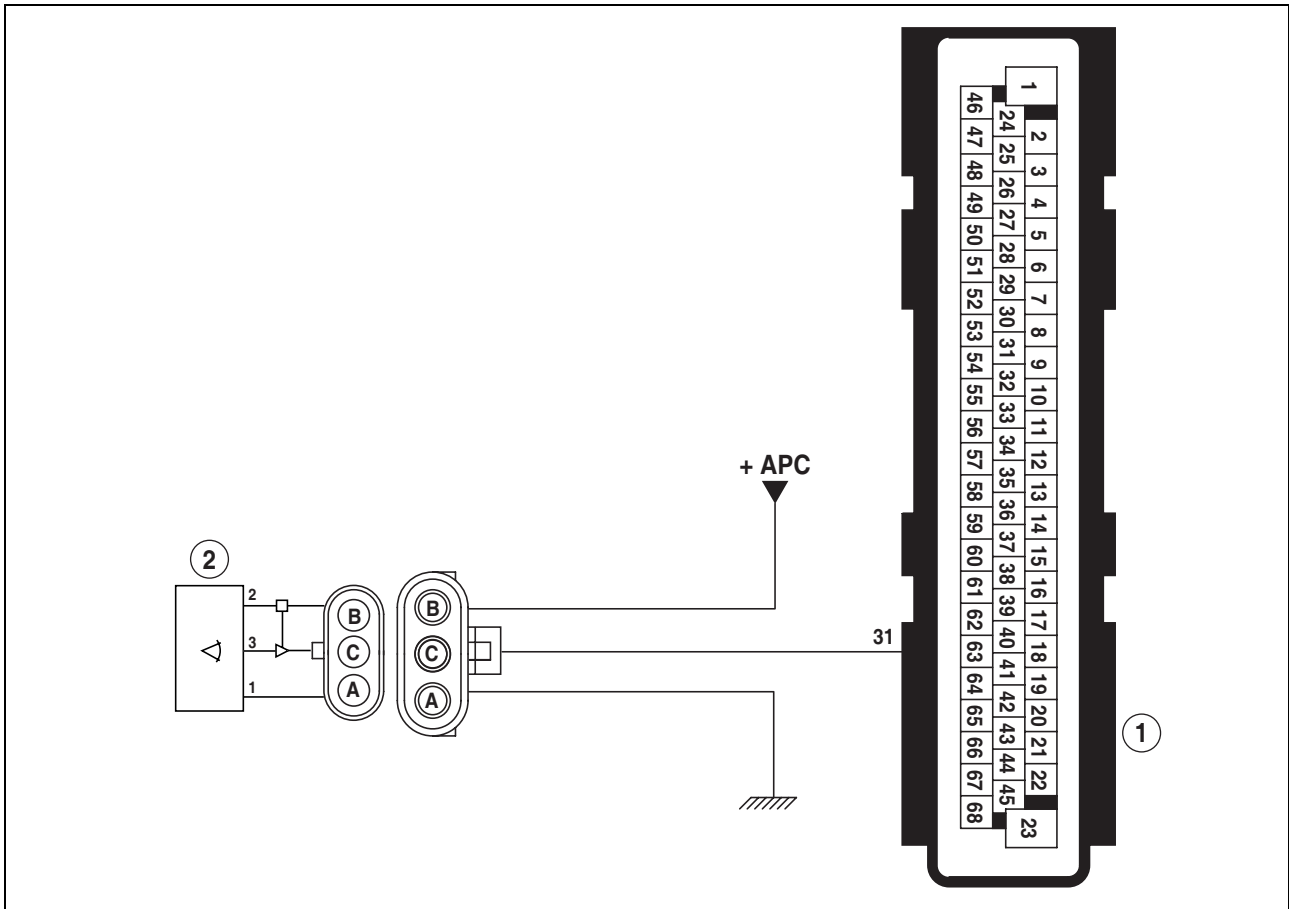

582hsm08

Fig. 37

Parts list

- 1 Engine control unit connector.
- 2 Accelerator pedal sensor.

Code SPN 91 FMI 3 is declared if

- The accelerator input voltage (C) exceeds the sensor's maximum threshold. The voltage exceeds the upper limit of the throttle control lever capacity.
- The maximum analog accelerator input voltage threshold (C) is 4,7 V.

This is what happens if the SPN 91 FMI 3 code is in force

The control unit uses a default "return to workshop" accelerator value which allows the engine to idle only.

1. Check the connection

Carry out a preliminary inspection of the engine control unit connector, the analog accelerator connector and all connectors linking these components. Find any dirty, worn or badly positioned terminals.

No defective connection

Go to 2.

Defective connection(s)

Repair the defective connection(s).

2. Possible causes

- Sensor connector faulty.
- Short circuit on accelerator input voltage.
- Accelerator sensor faulty.
- Control unit connector faulty.
- Control unit faulty.

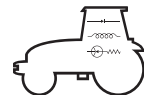

Engine application

3. Look for obstruction in the fuel return pipes

No obstruction in the fuel return pipes. Possible causes

- Injection pump overflow valve faulty;
- Fuel cooler faulty;
- Injection pump faulty.

Obstruction in a fuel return pipe

Repair and carry out the test again.

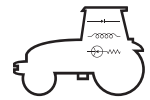

Engine application

Anomaly code SPN 632 FMI 2 Fuel cutout error

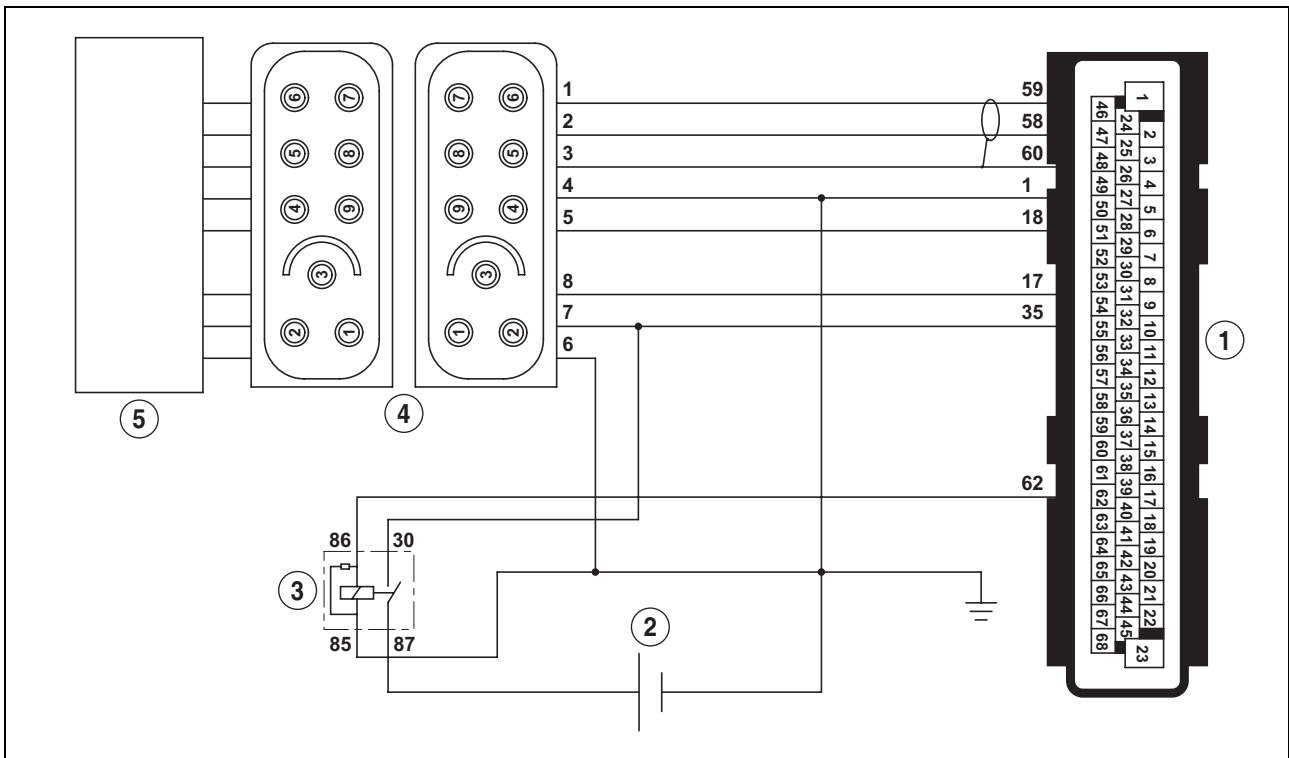

582hsm06

Fig. 56

Parts list

- | | | |
|----------------------------------|-----------------------------|-------------------|
| 1 Engine control unit connector. | 4 Pump connector. | 58 CAN-high. |
| 2 Battery. | 5 Rotary injection pump. | 59 CAN-low. |
| 3 Rotary pump relay. | 17 Crankshaft speed output. | 60 CAN shielding. |
| | 18 Fuel cutout. | |

Code SPN 632 FMI 2 is declared if

The pump control unit detects a fuel cutout voltage which does not correspond to the information communicated on the CAN.

This is what happens if the SPN 632 FMI 2 code is in force

The engine cuts out and cannot be restarted.

1. Check the connection

Carry out a preliminary inspection of the engine control unit connector and the injection pump connector. Find any dirty, worn or badly positioned terminals.

2. Check the injection pump voltage

1. Master switch off.
2. Unplug the injection pump connector.
3. Ignition on, engine off.
4. With a multimeter, measure the voltage between a good chassis earth and terminal (5) of the injection pump connector.

No defective connection

Go to 2.

Defective connection(s)

Repair the defective connection(s).

Battery voltage present

Go to 3.

Battery voltage zero

Injection pump connector faulty.
Or
Injection pump faulty.

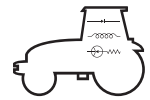

Engine application

Anomaly code SPN 637 FMI 8 No crankshaft position input

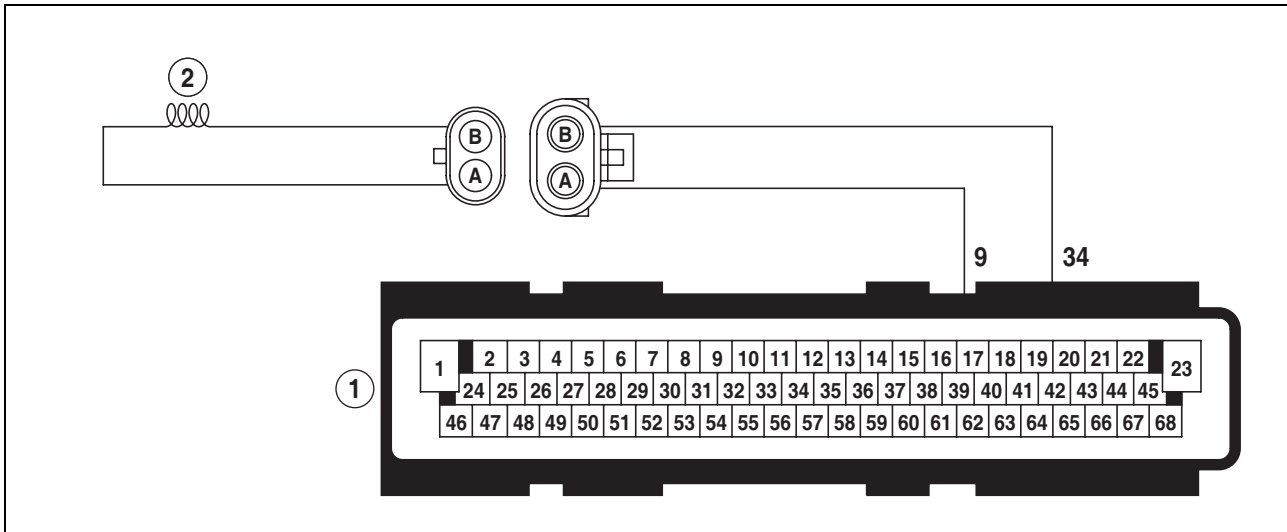

582hsm07

Fig. 62

Parts list

- 1 Engine control unit connector.
- 2 Crankshaft position sensor.
- 9 Crankshaft position input signal.
- 34 Crankshaft position return.

Code SPN 637 FMI 8 is declared if

The engine control unit fails to detect a crankshaft position input.

This is what happens if the SPN 637 FMI 8 code is in force

The engine reduces its power by 20% per minute until it reaches 50% of its maximum power. If a pump position sensor anomaly code appears at the same time as code SPN 637 FMI 8, the engine stalls and cannot be restarted until one of these 2 codes has been eliminated. The engine control unit will base itself only on the pump position sensor input in determining the piston position. At the precise moment when the anomaly code is declared, the engine might shudder or stall but it should restart. The engine may take longer to activate before starting.

1. Check the connection

Carry out a preliminary inspection of the engine control unit connector, the crankshaft position sensor connector and all connectors linking these components. Find any dirty, worn or badly positioned terminals.

2. Check the crankshaft position sensor

- 1 Master switch off.
- 2 Remove the crankshaft position sensor from the timing cover and look for signs of damage, such as cracks or debris on the sensor tip.

3. Crankshaft position sensor test

- 1 Master switch off.
- 2 Disconnect the crankshaft position sensor switch.
- 3 Measure with the multimeter the resistance between the 2 terminals of the crankshaft position sensor.

No defective connection

Go to 2.

Defective connection(s)

Repair the defective connection(s).

No signs of damage

Go to 3.

Sensor damaged

Determine the cause of the damage to the sensor. Replace the sensor and test again.

From 2 500 to 3 500 Ω

Go to 4.

Less than 2 500 Ω or more than 3 500 Ω

Crankshaft position sensor defective.

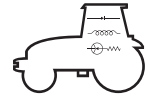

Engine application

Anomaly code SPN 1077 FMI 31

Code SPN 1077 FMI 31 is declared if

- The pump control unit detects an extremely high fuel temperature.
- The fuel temperature input voltage received by the pump control unit is outside the range of what is physically possible for the fuel temperature.
- The pump control unit detects that the high-pressure solenoid valve is constantly energised and is incapable of detecting the closure of the high-pressure solenoid valve, or the pump's internal speed sensor is broken.
- The pump control unit detects that the components located inside the pump are not working properly.
- The pump control unit detects a crankshaft signal sent by the engine control unit and out of range in relation to the pump's internal timing.

This is what happens if code SPN 1077 FMI 31 is in force

If the code is declared while the engine is not running, it is possible that the engine is failing to start. The engine protection function is activated. The engine reduces its power by 20% per minute until it reaches 50% of its maximum power.

One of the following codes is active

SPN 174 FMI 0, SPN 174 FMI 31, SPN 1076 FMI 2, 1077 FMI 12,
SPN 1078 FMI 7, SPN 1078 FMI 31.

Refer to the anomaly code.

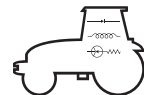

Engine application

3. Search for a cut in the rotary pump earth wire

- 1 Ignition on, engine off.
- 2 With a multimeter, measure the voltage between terminal (30) and terminal (85) of the rotary pump relay connector.

4. Check the relay control voltage

- 1 Ignition on, engine off.
- 2 With a multimeter, measure the voltage between terminal (86) of the rotary pump relay connector on the engine wiring harness and a good earth on the chassis.

5. Check the resistance of the pump control unit supply wire

- 1 Master switch off.
- 2 Unplug the injection pump connector.
- 3 With a multimeter, measure the resistance between terminal (7) of the injection pump connector and terminal (30) of the rotary pump relay connector.

6. Check the resistance of the pump control unit activation wire

- 1 Master switch off.
- 2 Disconnect the engine control unit switch.
- 3 With a multimeter, measure the resistance between terminal (62) of the engine control unit connector and terminal (86) of the pump relay connector.

7. Check the voltage of the pump control unit wire at the injection pump

- 1 Master switch off.
- 2 Unplug the injection pump connector.
- 3 With a multimeter, measure the voltage between terminal (7) of the injection pump connector and a good earth on the chassis.
- 4 Ignition on, engine off.
- 5 Measure the voltage at the same point.

8. Search for a short circuit on powering the pump control unit supply wire

- 1 Master switch off.
- 2 Unplug the rotary pump relay connector.
- 3 Ignition on, engine off.
- 4 With a multimeter, measure the voltage between terminal (30) of the pump relay connector and a good earth on the chassis.

9. Search for a opening on the pump control unit supply wire

- 1 Master switch off.
- 2 Unplug the engine control unit connector and the rotary pump relay connector.
- 3 With a multimeter, measure the resistance between terminal (35) of the engine control unit connector and terminal (30) of the rotary pump relay connector.

Close to the battery voltage

Go to 4.

Much lower than the battery voltage

Circuit open on the rotary pump relay earth wire.

Close to the battery voltage

Go to 5.

Much lower than the battery voltage

Go to 6.

Under 5 Ω

Pump relay connector faulty.

Or

Pump relay faulty.

Over 5 Ω

Pump control unit supply wire faulty.

Under 5 Ω

Engine control unit connector faulty.

Or

Engine control unit faulty.

Over 5 Ω

Pump control unit activation wire faulty.

Close to the battery voltage with ignition on and off

Go to 9.

Voltage zero with ignition off and close to the battery voltage with ignition on

Go to 8.

Much lower than the battery voltage

Pump relay faulty.

Close to the battery voltage

Short circuit on supply to the pump control unit supply wire.

Under 5 Ω

Engine control unit connector faulty.

Or

Engine control unit faulty.

Over 5 Ω

Circuit open on the pump control unit supply wire.

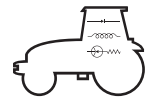

Transmission application

Ranges

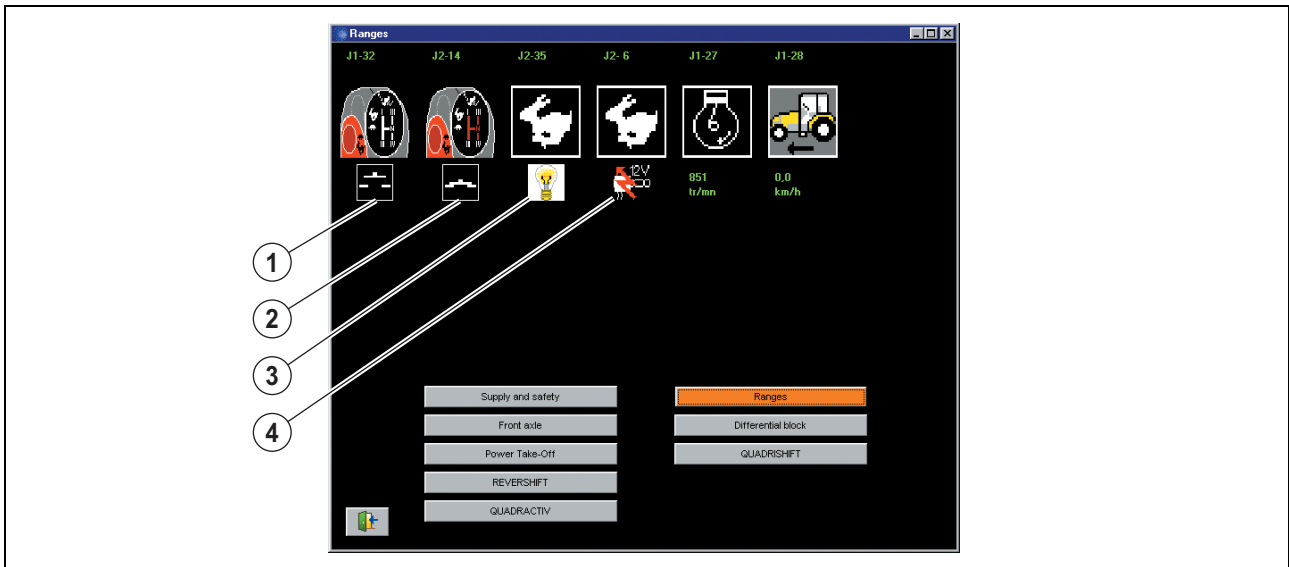

586hsm15

Fig. 83

Parts list

- | | |
|--|-------------------------|
| 1 Field/road range lever switch. | 3 Field lamp output. |
| 2 Neutral logic input (switch on gearbox cover). | 4 Range solenoid valve. |

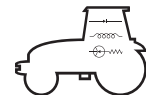

Transmission application

List of "RCC" error codes

Code	Cause
121	Excessive battery (regulator) voltage.
122	Insufficient battery (regulator) voltage.
123	Excessive engine oil pressure sensor signal.
124	Insufficient engine oil pressure sensor signal.
125	Excessive engine temperature sensor signal.
126	Insufficient engine temperature sensor signal.
127	Excessive fuel gauge signal.
128	Insufficient fuel gauge signal.
129	Excessive battery voltage.
130	Insufficient battery voltage.
131	Excessive turbo pressure sensor signal.
132	Insufficient turbo pressure sensor signal.
133	Excessive steering angle sensor signal.
134	Insufficient steering angle sensor signal.
139	Excessive approach pedal potentiometer signal.
140	Insufficient approach pedal potentiometer signal.
141	Engine speed out of range.
142	Pedal top switch (TOC) short circuit to + 12 V.
143	Pedal bottom switch (BOC) short circuit to + 12 V.
144	Neutral switch (normally open) short circuit to + 12 V.
145	Neutral switch (normally open) short circuit to + 12 V.
146	Neutral switch (normally closed) short circuit to + 12 V.
147	Neutral switch (normally open) short circuit to earth.
148	Reprogramming attempted with engine running.
149	CAN error.
150	Loss of message on CAN.
151	Transmission output speed out of limit.
152	Engine hourmeter error.
153	"EEPROM" monitoring problem.
154	Communication error between "RCC" and "TC".
156	Top pedal switch (TOC) remained open.
157	No engine speed signal.
158	Transmission speed sensor error.
159	Engine torque too low (Atles only, "EMR" unit).
160	Engine torque too high (Atles only, "EMR" unit).
161	No engine torque information (Atles only, "EMR" unit).
162	Unstable engine torque (Atles only, "EMR" unit).

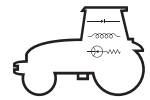

Rear lift application

TCE 15-25



586hsm39

Fig. 113

Parts list

- 1 Choice of language.
- 2 Choice of lift type.
- 3 Keyboard shortcut.
- 4 Help.
- 5 Version.
- 6 Exit.

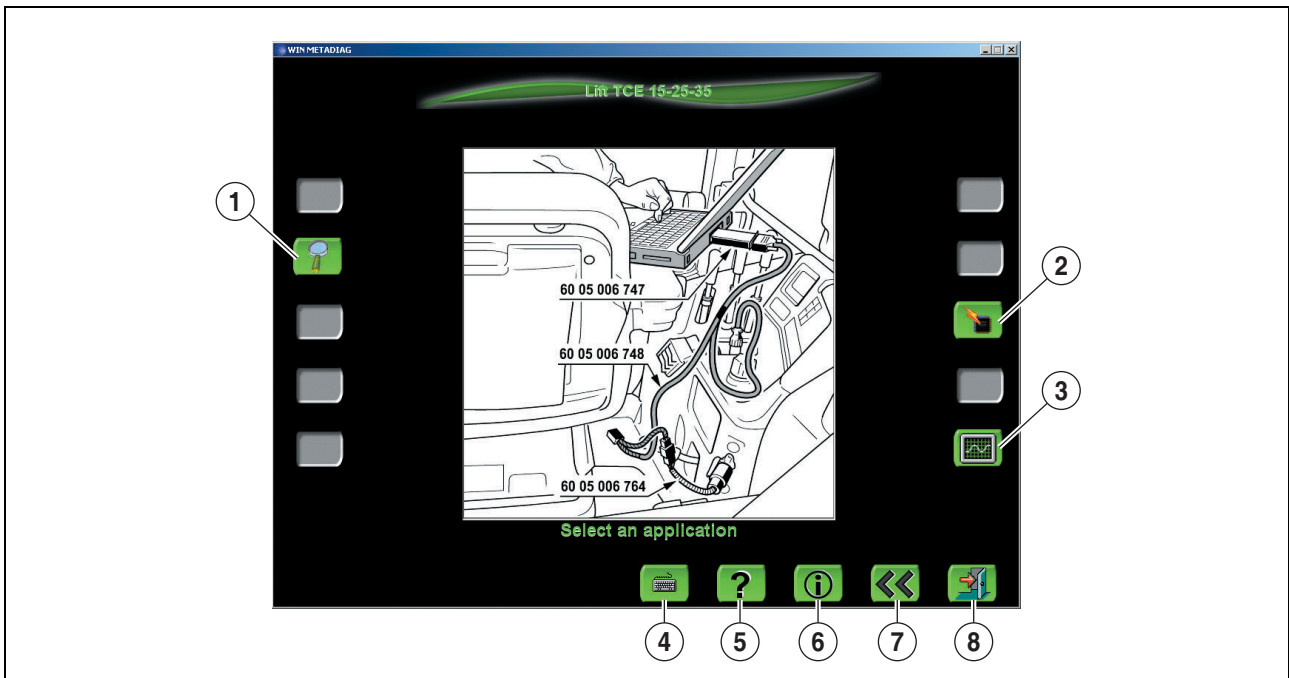

586hsm40

Fig. 114

Parts list

- 1 Overview.
- 2 Programming.
- 3 Calibration.
- 4 Keyboard shortcut.
- 5 Help.
- 6 Version.
- 7 Return to previous mask.
- 8 Exit.

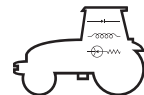

Electropilot application

Error codes

Error code	Flashing				Joystick	Spool valve n° 1	Spool valve n° 2	Description of errors	Possible causes
	On	Slow	Fast	Off					
0	X								
17		X				X	'SETPOINT' message not received	Actuator not connected. CAN faulty. Solenoid valve number setting incorrect. Actuator or valve periods incorrectly programmed. Data transfer rate in CAN incorrect.	
18		X				X	'CONFIGURATION' message not received	Actuator not connected. CAN faulty. Solenoid valve number setting incorrect. Actuator or valve periods incorrectly programmed. Data transfer rate in CAN incorrect.	
19		X				X	Formatting error in 'SETPOINT' message	The actuator signals an error on initialisation. A data byte contains an invalid value 'FF'. Several simultaneous commands requested.	
20		X				X	Formatting error in 'CONFIGURATION' message	The actuator signals an error on initialisation. A data byte contains an invalid value 'FF'.	
22		X				X	EEPROM incoherent	EEPROM incorrectly programmed. Faulty EEPROM cell.	
23		X				X	Mandatory return to neutral (voltage error)	—	
33		X				X	Under-supply	Battery voltage too low. Lowest battery voltage value programmed in EEPROM incorrect. Excessive battery voltage hysteresis programmed in the EEPROM.	
34		X				X	Over-supply	Battery voltage too high. Highest battery voltage value programmed in EEPROM incorrect. Excessive battery voltage hysteresis programmed in the EEPROM.	
35		X					Spool movement too short	Insufficient control pressure due to too many consumers and insufficient speed of rotation. Solenoid valve jammed. Oil viscosity too high. Temperature too low. Position transducer faulty or connector loose.	
36		X				X	Excessive slide movement	Insufficient control pressure due to too many consumers and insufficient speed of rotation. Solenoid valve jammed. Oil viscosity too high. Temperature too low. Position transducer faulty or connector loose.	

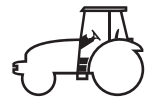

Description

Right side (location of operations)

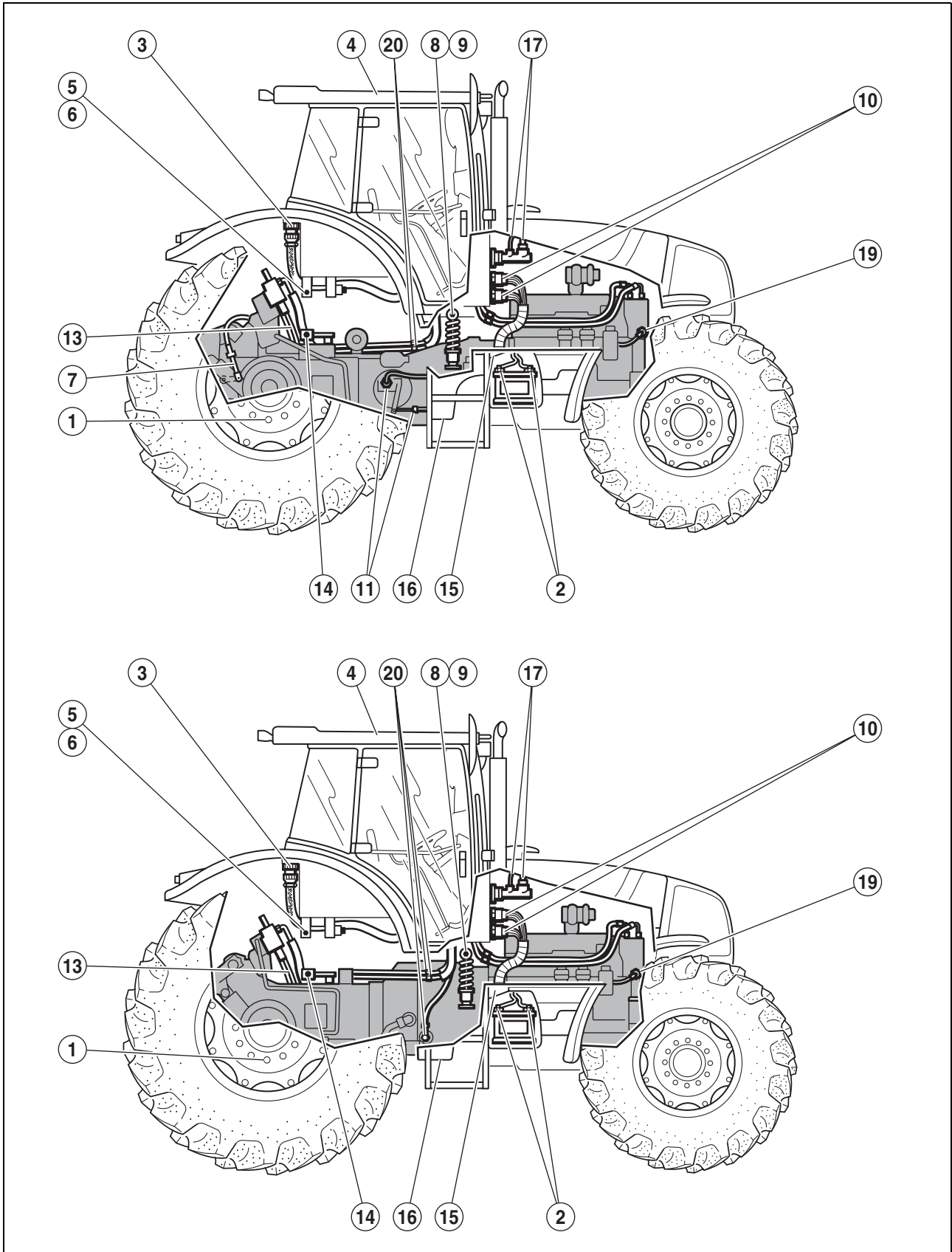

CLICK HERE TO **DOWNLOAD** THE COMPLETE MANUAL

- Thank you very much for reading the preview of the manual.
- You can download the complete manual from: www.heydownloads.com by clicking the link below



- Please note: If there is no response to CLICKING the link, please download this PDF first and then click on it.

CLICK HERE TO **DOWNLOAD** THE COMPLETE MANUAL