

NEF ENGINE

**N45 MNA M10
N67 MNA M15**

**TECHNICAL AND REPAIR
MANUAL**

MARCH 2006 EDITION

TECHNOLOGICAL EXCELLENCE

**IVECO
MOTORS**



CLICK HERE TO **DOWNLOAD** THE COMPLETE MANUAL

- Thank you very much for reading the preview of the manual.
- You can download the complete manual from: www.heydownloads.com by clicking the link below



- Please note: If there is no response to CLICKING the link, please download this PDF first and then click on it.

CLICK HERE TO **DOWNLOAD** THE COMPLETE MANUAL

Figure 4

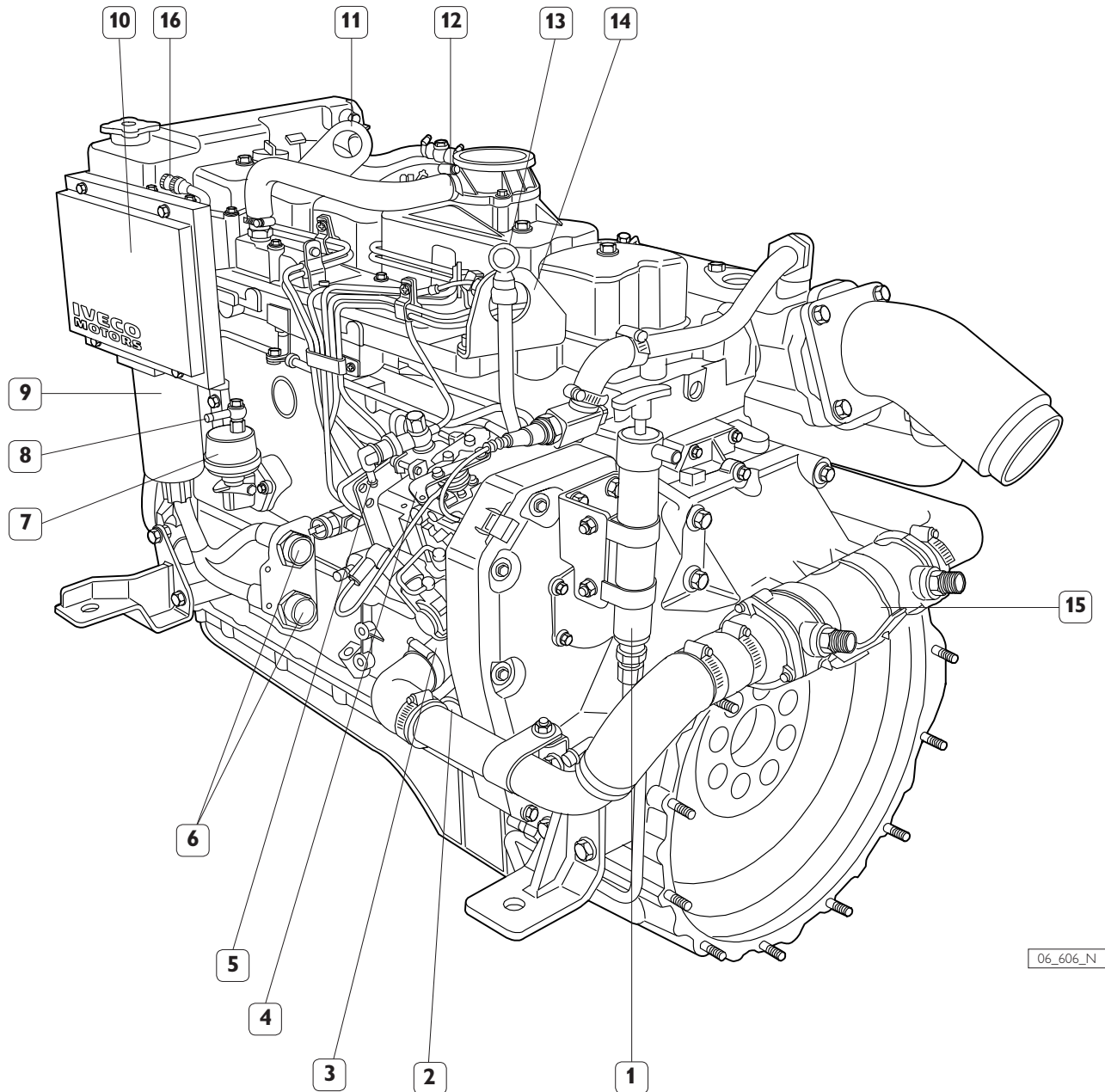

06_606_N

1. Manual lubricating oil extraction pump - 2. Sea-water inlet - 3. Sea-water pump - 4. Throttle lever lever on injection pump - 5. Rubber holder junction for fuel outflow to the tank - 6. Wiring connectors N45 MNA M10.00 and N67 MNA M15.00 - 7. Low pressure mechanical feed pump - 8. Fuel intake fitting - 9. Fuel filter - 10. Combustion air filter - 11. Lifting eyebolt - 12. Oil vapours vent - 13. Oil dipstick - 14. Lifting eyebolt - 15. Sea-water junction pipe from after-cooler to engine coolant/sea-water heat exchanger (Oil gearbox heat exchanger, on request) - 16. Connector for instrument panel connection wire harness N45 MNA M10.01 and N67 MNA M15.01.

Exhaust manifold cooling

Figure 20

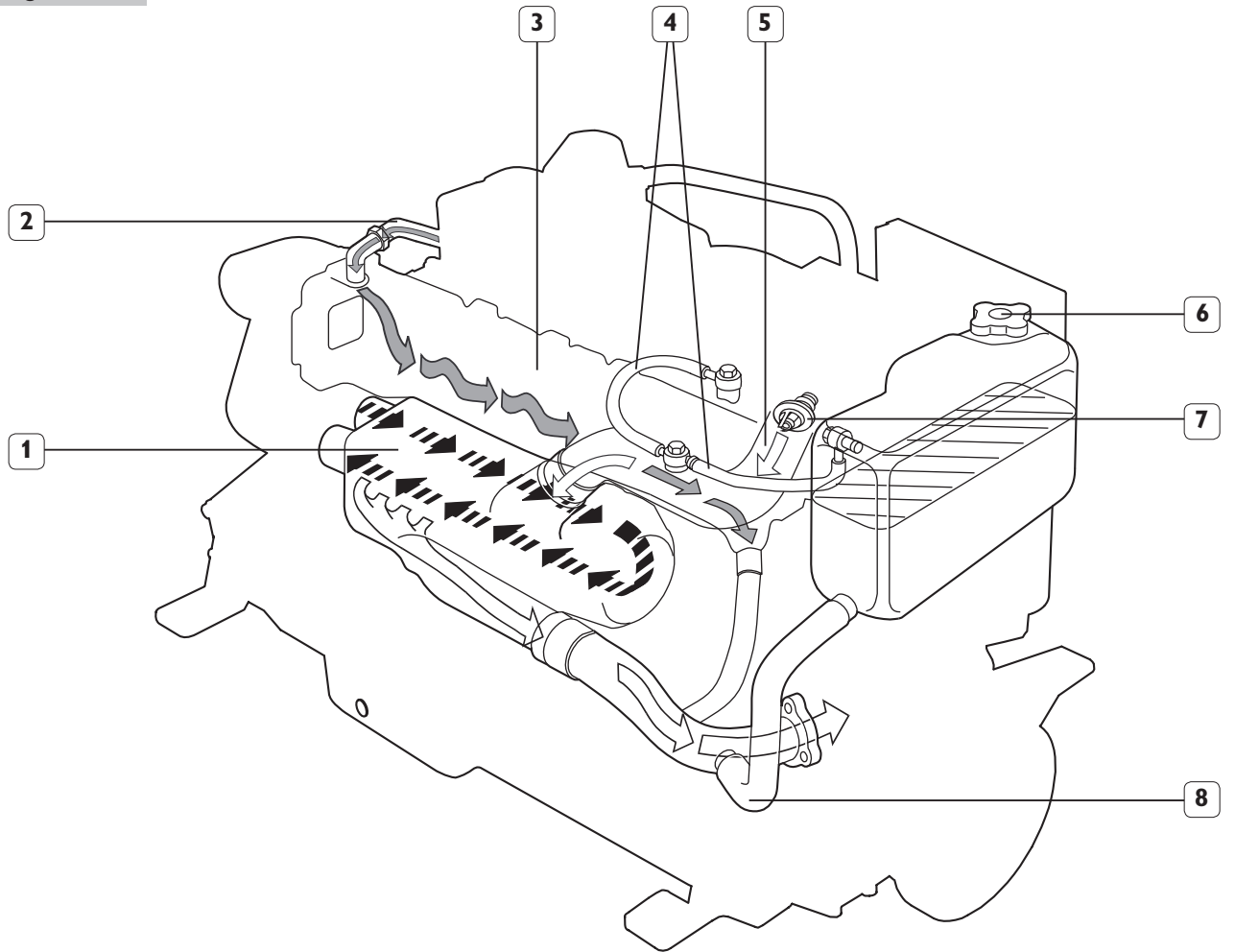

04_413_N

- Engine coolant going through exhaust manifold
- Hot engine coolant going through coolant exchanger
- Sea-water

1. Sea-water/coolant exchanger - 2. Pipe for the entrance of the refrigerating liquid into the exhaust induction - 3. Exhaust manifold - 4. Degassing piping - 5. Thermostatic valve water / water exchanger connector - 6. Plug with pressure valve - 7. Thermostatic valve - 8. Water pump manifold inlet.

SECTION 2

TECHNICAL DATA

	Page
GENERAL SPECIFICATIONS	33
Dimensions	35

ELECTRICAL STARTER MOTOR

Figure 5

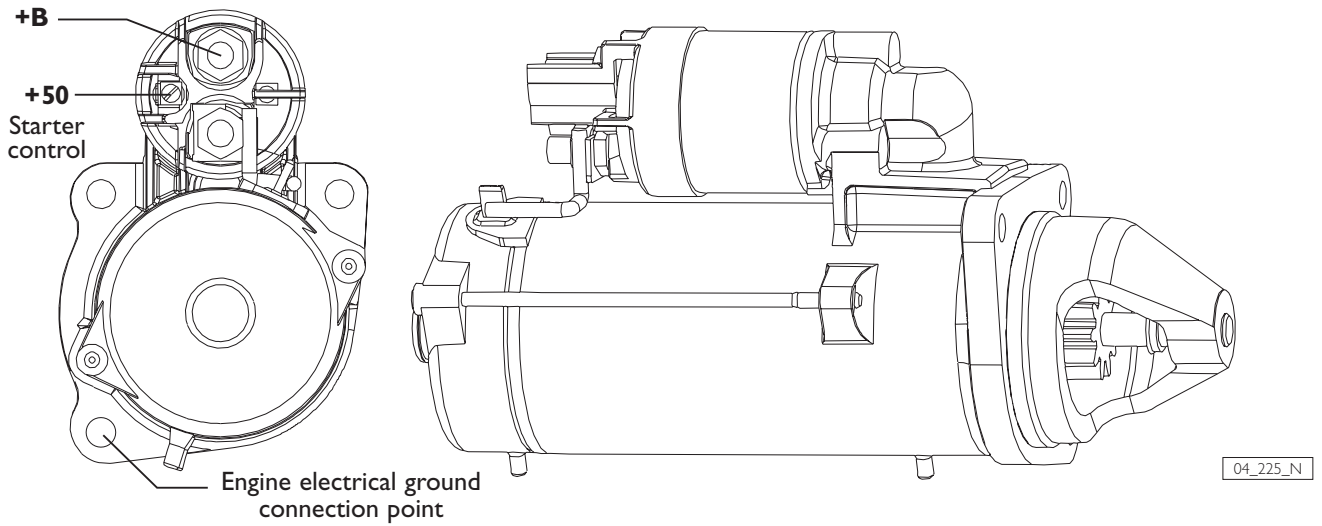

“Bosch” Model - Specifications

Nominal power	4.3 kW	Rotation	Clockwise viewed from pinion end
Nominal voltage	12 V	Operating voltage	13 V max (20 °C)
Polarity	Negative ground	Water resistance	Water spray test based on JIS D0203 SI
Engagement circuit	Positive command		

Figure 6

RPM	kW	Nm	V
2600	65	130	13
2400	60	120	12
2200	55	110	11
2000	50	100	10
1800	45	90	9
1600	40	80	8
1400	35	70	7
1200	30	60	6
1000	25	50	5
800	20	40	4
600	15	30	3
400	10	20	2
200	5	10	1
0	0	0	0

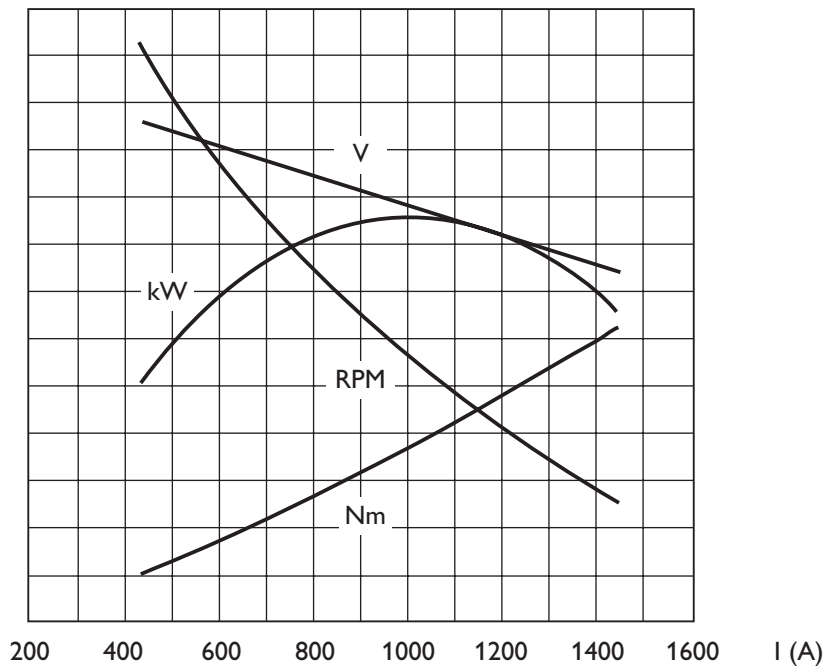

CHARACTERISTIC CURVES

04_226_N

M10.01/M15.01 WIRE HARNESS

Figure 20

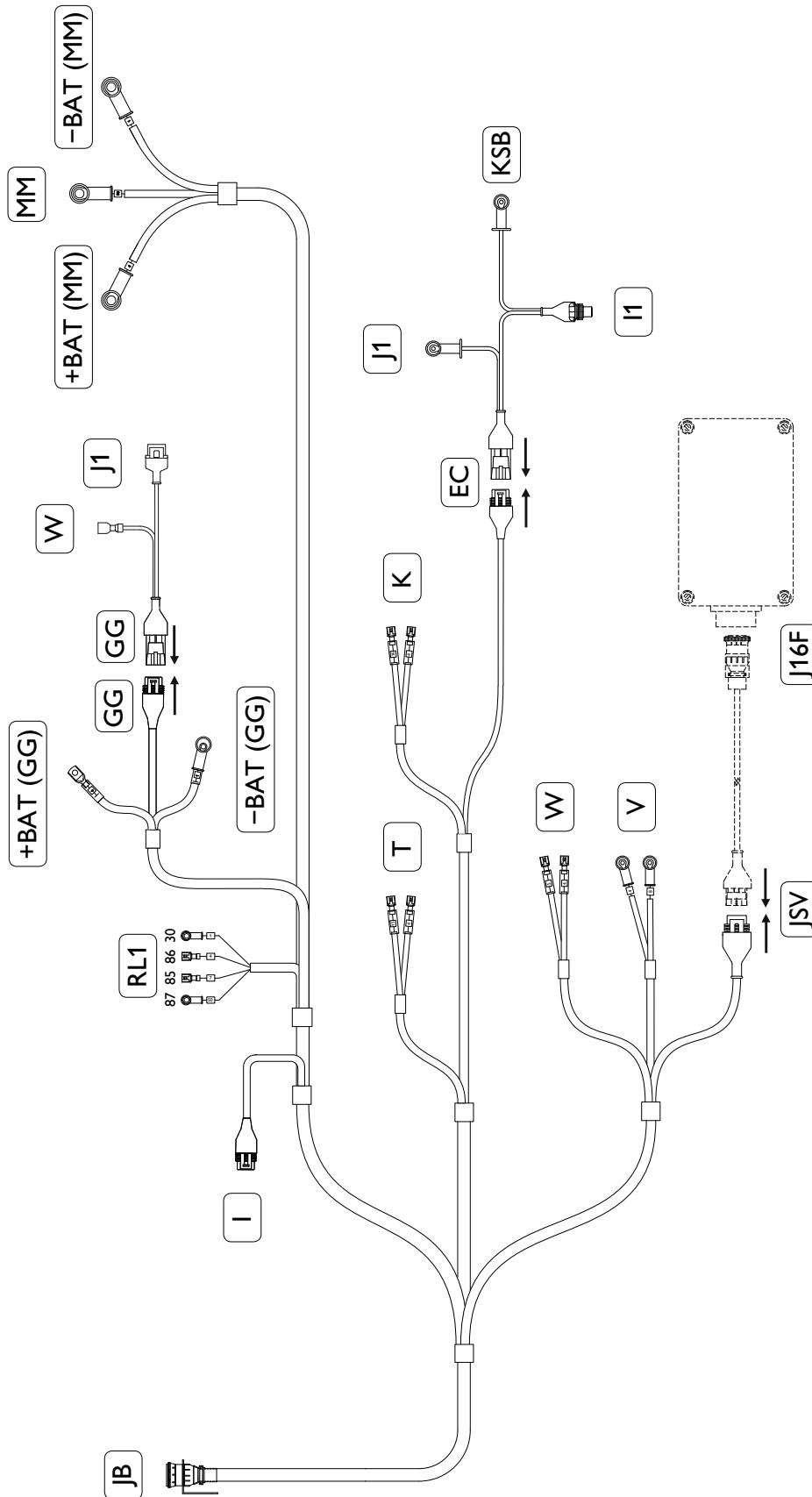

I. High coolant temperature sensor (for alarm) - K. Air filter clogging sensor (for alarm) - T. Coolant temperature sensor (for gauge) - V. Oil pressure sensor (for gauge) - W. Low oil pressure sensor (for alarm) - W. Signal for revolution counter - EC. Injection pump connector - I1. KSB Refrigerating liquid temperature sensor - J1. Engine stop solenoid valve - KSB. Cold injection advance adjustment device - GG. Connector for alternator - JB. Instrument panel connection wire harness - J1. Alternator excitation - JSV. Over speed module connector - J16F. Engine rotation over speed control module (on request) - RL1. Starter relay motor - MM. Electric starter motor.

FOREWORD

A proper diagnosis is reached through the competence acquired with years of experience and attending training courses.

When the user complains of poor performance or operating anomalies, due consideration must be given to his/her indications, in order to derive useful information that will orient our actions.

After ascertaining the existence of the anomaly, we recommend starting troubleshooting operations with tests and measurements, to obtain a picture of the overall operating conditions and identify the real fault causes.

If adopted diagnostic modes provide no indications, proceed to check ratings and technical data provided in the "N45 MNA M10 - N67 MNA M15 Installation Directive" document.

We have provided, in the following pages, a TROUBLESHOOTING GUIDE organized by symptoms, describing the possible anomalies not recognized by the electronic unit, frequently mechanical or hydraulic in nature.

For operation and maintenance instructions, see the indications provided in Section 5.

CLICK HERE TO **DOWNLOAD** THE COMPLETE MANUAL

- Thank you very much for reading the preview of the manual.
- You can download the complete manual from: www.heydownloads.com by clicking the link below



- Please note: If there is no response to CLICKING the link, please download this PDF first and then click on it.

CLICK HERE TO **DOWNLOAD** THE COMPLETE MANUAL

ADJUSTING INJECTION PUMP TIMING

It requires to ensure the exact pumper position of injection pump compared to an exact angular position of crankshaft.

Figure 4

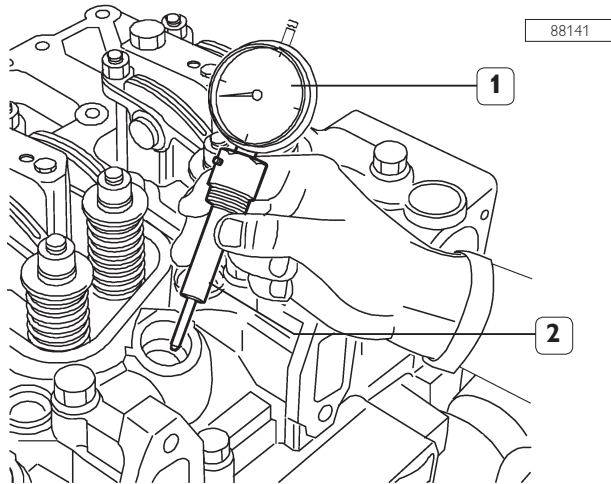

Bring the cylinder 1 piston to T.D.C., compression end, proceeding as follows:

- ❑ Rotate crankshaft in a position where both intake and exhaust valves are closed;
- ❑ Swap the cylinder 1 injector with tool 99395097 (1) inclusive of centesimal dial gauge, and preload the dial gauge;
- ❑ Rotate the crankshaft in the opposite direction to normal rotation, until reaching the lesser value on the dial gauge;
- ❑ Carefully rotate the crankshaft in the normal direction of rotation, until reaching the maximum value on the dial gauge (corresponding to cylinder 1 piston T.D.C. position);
- ❑ Verify that both intake and exhaust valves are closed, then set the dial gauge to zero.

Figure 5

04_419_N

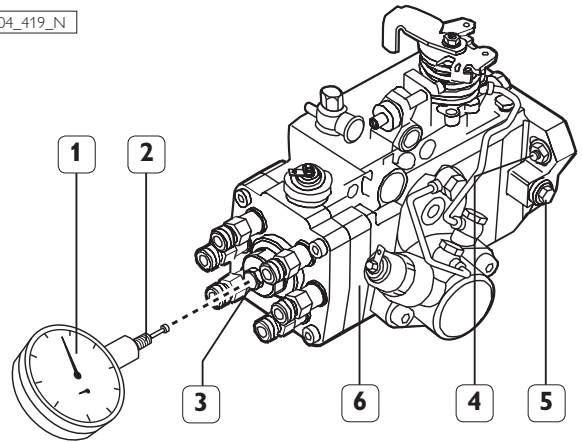

- ❑ Remove the screw (3) and screw the tool 99395100 (2), inclusive of centesimal dial gauge (1), ensuring that the shaft is making contact with the pumper;
- ❑ Preload the dial gauge by 3 mm;
- ❑ Rotate the crankshaft in the opposite direction to normal rotation, until the pumper reaches its own B.D.C., as shown by the dial gauge;
- ❑ Set the dial gauge to zero;
- ❑ Rotate the crankshaft of about 30° in the opposite direction to normal rotation;
- ❑ Carefully rotate the crankshaft in the normal direction of rotation, until reading the 0.00 mm value on the dial gauge (1) of tool 99395097 (Fig. 4), corresponding to cylinder 1 piston T.D.C. position;
- ❑ Partially loosen the lateral screw (5) locking the pump shaft, without removing the slip washer;
- ❑ Loosen the pump fixing nuts (4) without remove them, so as to allow the pump body rotation;
- ❑ Carefully rotate the pump body until reading the prescribed pumper stroke value on the dial gauge (1) of tool 99395100 (Fig. 6) (see following table);
- ❑ Tighten the pump fixing nuts (4) and the lateral screw (5) to prescribed torque values; proceed with timing verification.

TOOLS

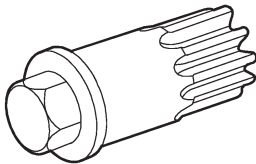
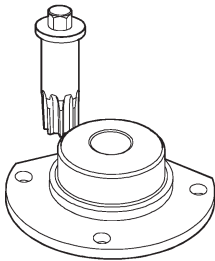
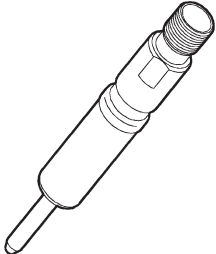
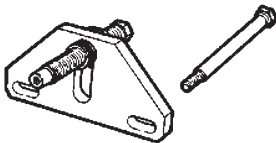
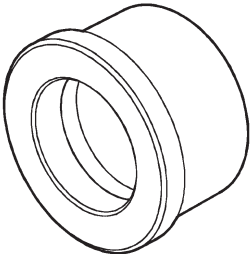
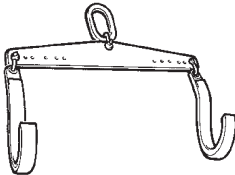
Tool No.	Definition	
99360330	 A cylindrical tool with a hexagonal end and a series of longitudinal ridges on the main body.	Flywheel crank handle
99360339	 A tool consisting of a circular base with four mounting holes and a vertical shaft with a cylindrical tip.	Tool for stopping the engine flywheel
99360344	 A long, thin cylindrical tool with a threaded section at one end and a tapered tip at the other.	Adapter; cylinder compression test (use with 99395682)
99360351	 A tool consisting of a triangular metal plate with a hole and a threaded rod passing through it, and a separate cylindrical component.	Tool for flywheel holding
99360362	 A thick, cylindrical metal ring with a flange on one side.	Beater for removing/refitting camshaft bushes (to be used with 993700069)
99360500	 A metal tool with a central hook and two curved lifting arms.	Tool for lifting the output shaft







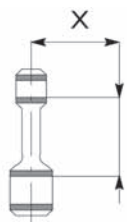
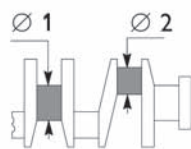
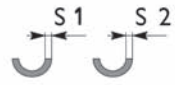
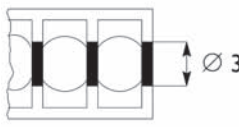

Type		N45 MNA M10	N67 MNA M15	
Cylinder unit and crankshaft components		mm		
	Size	X	-	
	Max. tolerance on connecting rod axis alignment	=	-	
	Journals	Ø 1	82.99 to 83.01	
	Crankpins	Ø 2	68.987 to 69.013	
	Main half bearings	S 1	2.456 to 2.464	
	Big end half bearings	S 2	1.955 to 1.968	
	Main bearings n° 1-7	Ø 3	87.982 to 88.008	
	n° 2-3-4-5-6	Ø 3	87.977 to 88.013	
	Half bearings - Journals n° 1-7		0.064 to 0.095	
	n° 2-3-4-5-6		0.059 to 0.100	
	Half bearings - Crankpins		0.033 to 0.041	
	  	Main half bearings Big end half bearings	+ 0.250 ; + 0.500	
	Shoulder journal	X 1	37,350 to 37,650	37,475 to 37,545
	Shoulder main bearing	X 2	31.730 to 32.280	
	Shoulder half-rings	X 3	37.28 to 37.38	
	Output shaft shoulder		0.095 to 0.270	

Figure 27

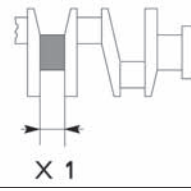
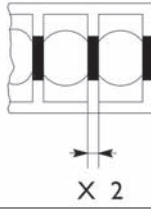
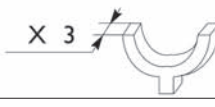

04_374_N

- ❑ Turn the engine upside-down;
- ❑ Assemble oil pan (1), apply the plate over it (2). Tighten the screws (2) and lock them to the prescribed couple.

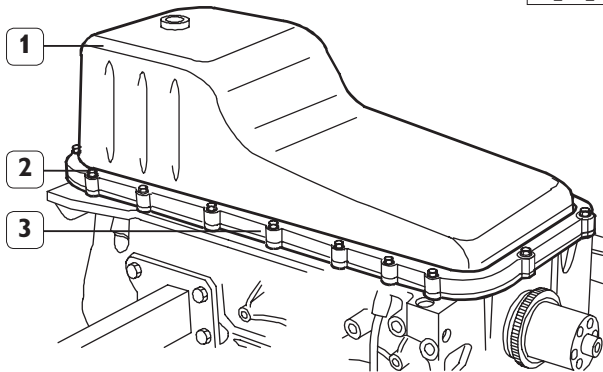
CAUTION

The shape and dimensions of the sump and of the rose pipe may vary according to the engine application. The relating illustrations provide general guidelines of the operation to be performed. The procedures described are applicable anyway.

Figure 28

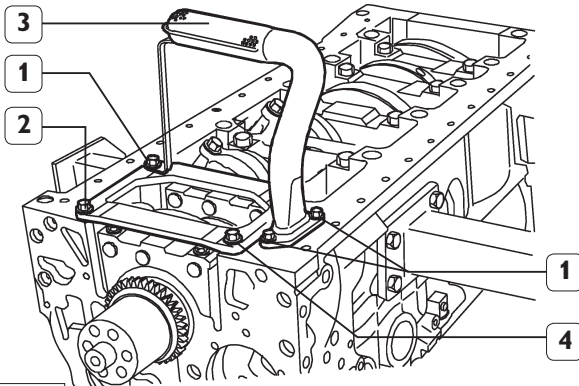

88074

- ❑ Loosen the screws (1) and disassemble the oil suction rose pipe (3);
- ❑ Loosen the screws (2) and remove the stiffening plate (4).

Figure 29

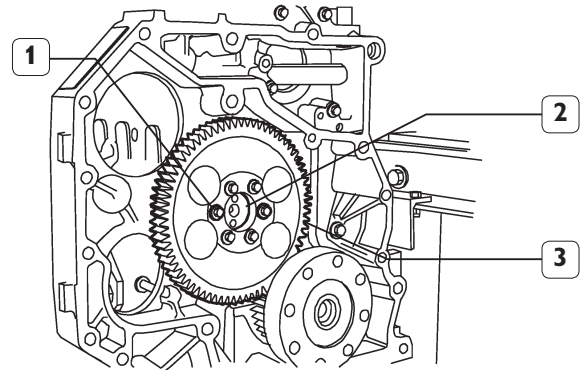
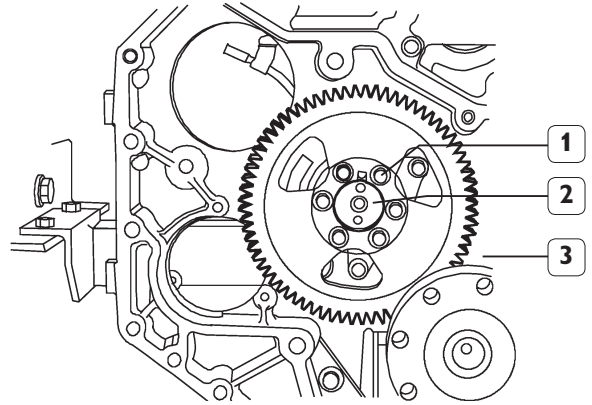

90505

- ❑ Loosen the screws (1) and disassemble the gear from the camshaft (2).

Figure 30

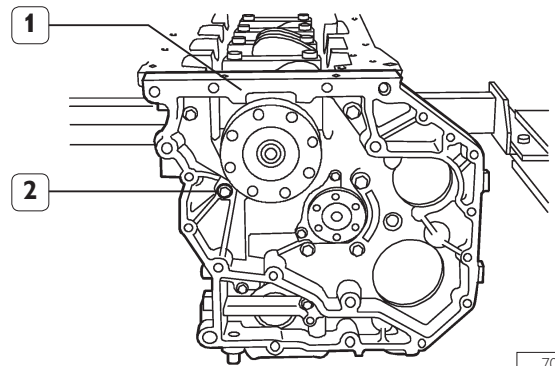

70157

- ❑ Loosen the screws (2) and disassemble the timing gear-box (1).

CAUTION

Take note of the screw (2) assembly position, since the screws have different length.

Measuring journals and crankpins (6 cylinders)

Figure 59

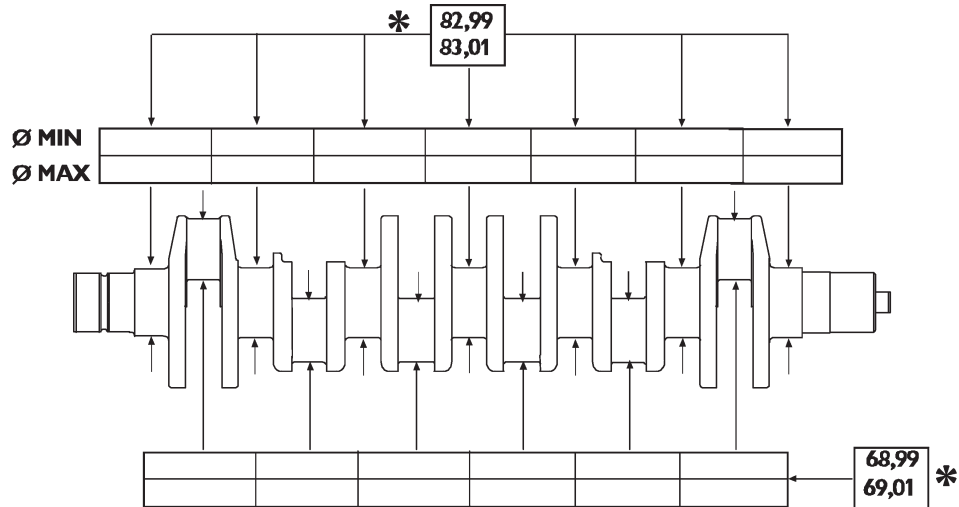

70514

FILL THIS TABLE WITH OUTPUT SHAFT JOURNAL AND CRANKPIN MEASURED VALUES

* Rated value.

Figure 60

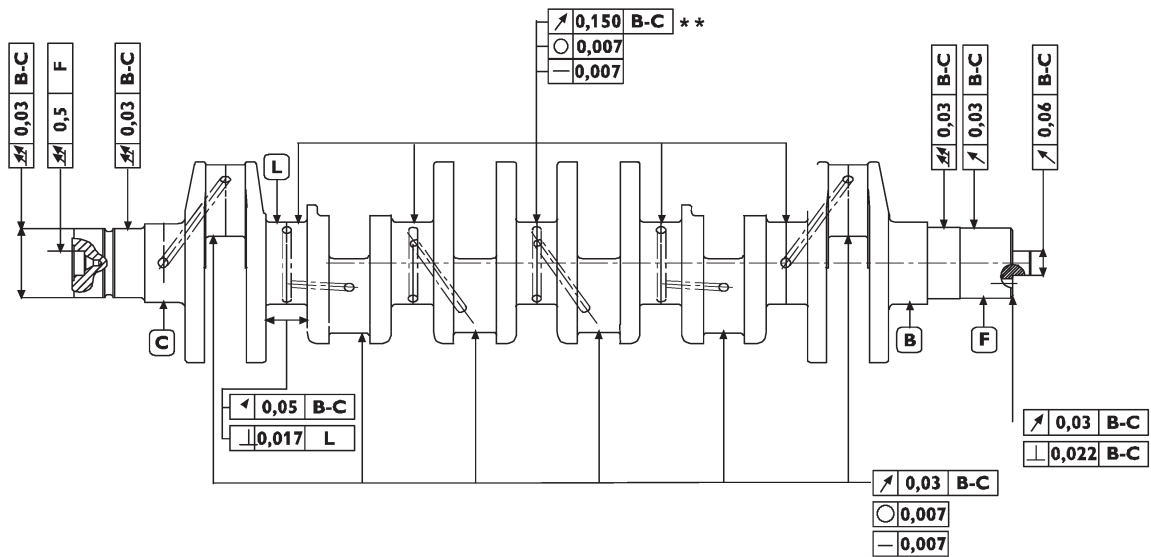

70577

MAIN OUTPUT SHAFT TOLERANCES

* Measured on a radius greater than 45.5 mm.

** \nearrow 0.500 between adjacent main journals.

Finding crankpin clearance

Figure 94

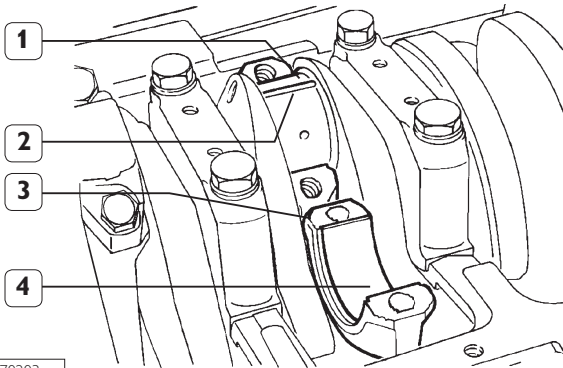

70203

To measure the clearance proceed as follows:

- ❑ Clean the parts accurately and remove any trace of oil;
- ❑ Set a piece of calibrated wire (2) on the output shaft pins (1);
- ❑ Fit the connecting rod caps (3) with the relevant half bearings (4).

Figure 95

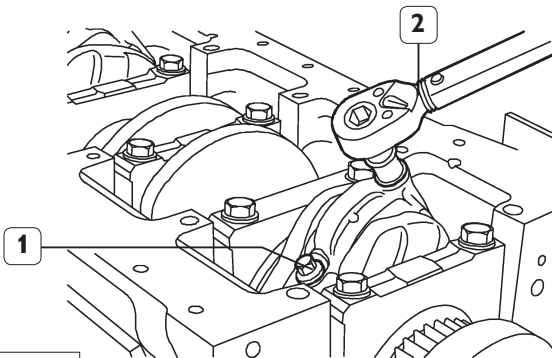

70204

- ❑ Lubricate the screws (1) with engine oil and then tighten them to the specified torque using the torque wrench (2).

Figure 96

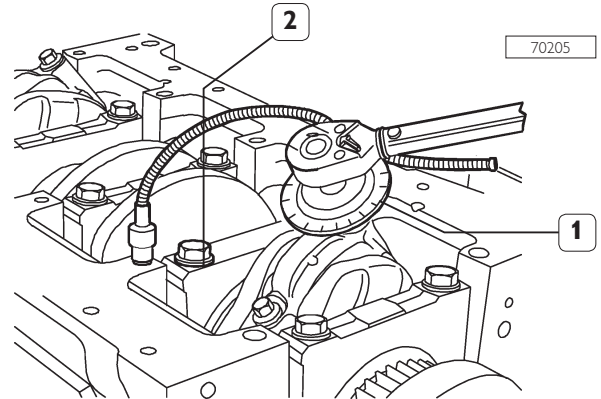

70205

- ❑ Apply tool 99395216 (1) to the socket wrench and tighten screws (2) of 60°.

Figure 97

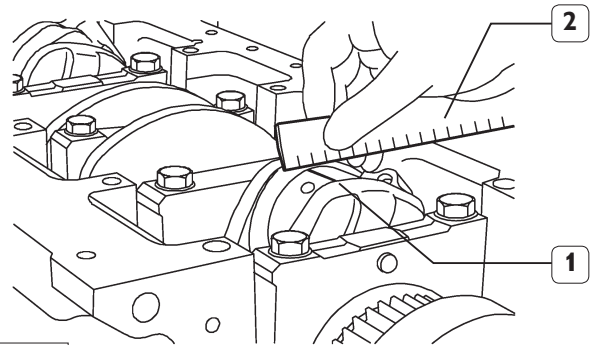

70206

- ❑ Remove the cap and find the existing clearance by comparing the calibrated wire width (1) with the scale on the wire envelope (2).

Figure 125

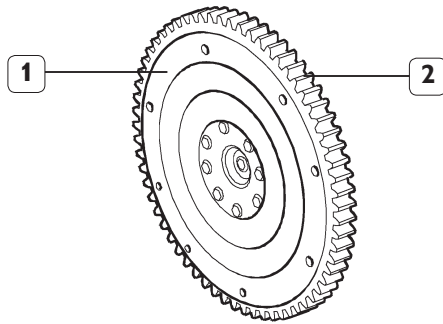

75696

Check the conditions of the rim tooth (2). Whether tooth break or excessive wear is detected, disassemble the rim from the engine flywheel using a common willow and replace with a new one, previously heated to 150 °C degrees for 15-20 seconds; bevelling must be made towards engine flywheel direction.

Figure 126

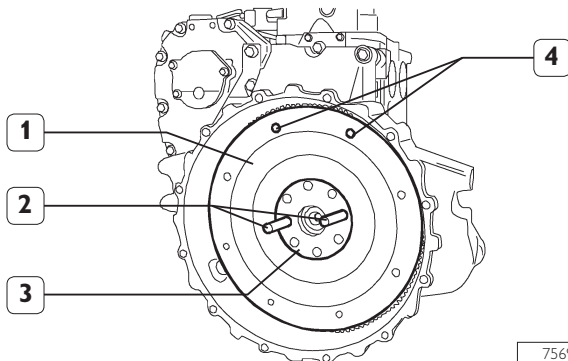

75690

- ❑ Screw down two hooks or trail rings in the flywheel (1) threaded ports (4) for handling;
- ❑ Using a hoist, handle the flywheel to place it in its housing inside the flywheel cover box;
- ❑ Screw down to pins (2) having appropriate length, in the shaft ports (3) and using them as guide, assemble the engine flywheel (1) properly placing it inside the flywheel cover box.

Figure 127

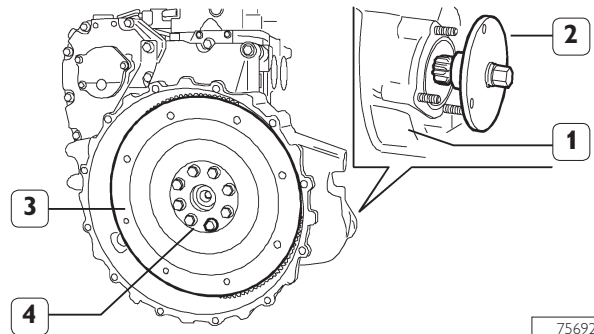

75692

- ❑ Tighten the screws (4) fixing the engine flywheel (3) to the engine shaft. Use tool 99360339 (2) to operate on the flywheel cover box (1) to block engine flywheel rotation.

Figure 128

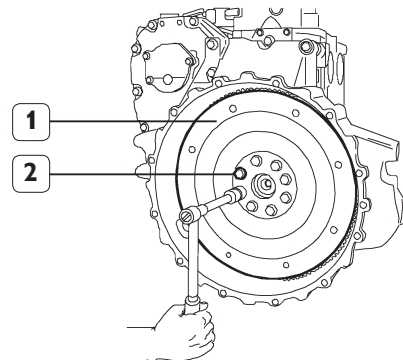

75695

Tighten the engine flywheel (1) fixing screws (2) in two phases:

- ❑ 1st phase; tightening by means of dynamometric wrench to torque 30 ± 4 Nm;
- ❑ 2nd phase, $60^\circ \pm 5^\circ$ angle dwell.

CAUTION

Angle dwell shall always be performed using 99395216 tool.

Before every assembly, always check that threads of holes and screws have no evidence of tear and wear nor dirt.

Figure 163

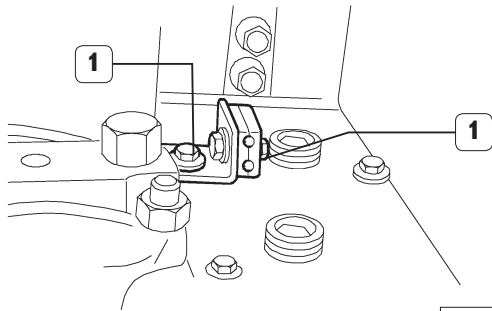

76208

- ❑ Also assemble the brackets (1) fixing the fuel pipelines to the injectors: use the same screws (2) fixing the manifold plate as shown in the picture;
- ❑ Also assemble feed pump (see specific procedure).

CAUTION

Pump mounting requires specific procedure contained in this section.

Figure 164

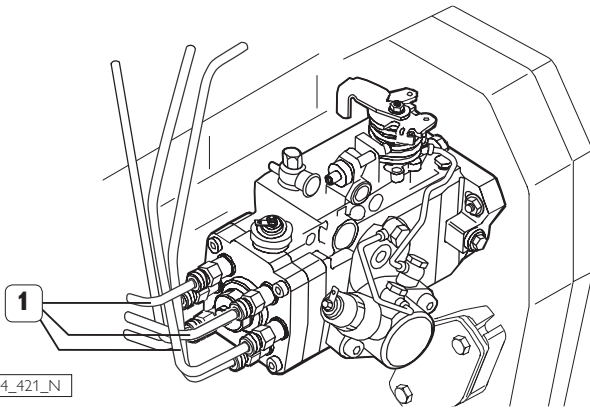

04_421_N

- ❑ Assemble the injection pump supply pipes (1);
- ❑ Screw down the locking nuts fixing the pipes to the injection pump;
- ❑ Tighten the screws fixing the fuel recovery manifold to the injection pump;
- ❑ Tighten the locking nuts on the injectors and tighten the screws to fasten the fuel recovery manifold.

Figure 165

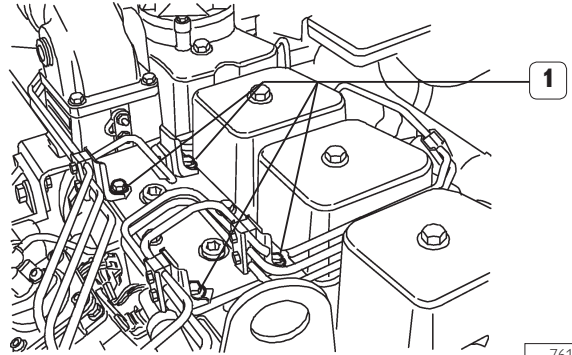

76148

- ❑ Fix the pipes to the injectors throughout the brackets previously assembled.

Figure 166

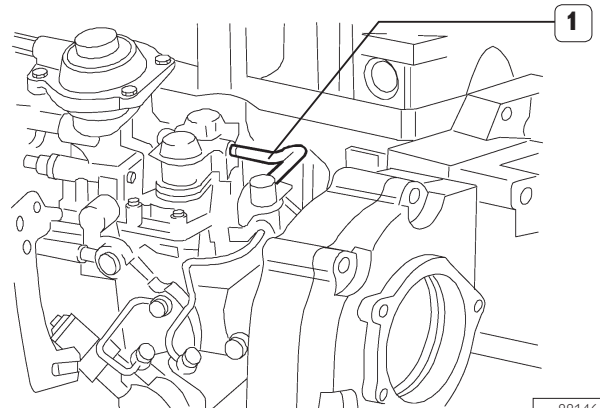

88146

- ❑ Assemble the injection pump pipe (1).

CLICK HERE TO **DOWNLOAD** THE COMPLETE MANUAL

- Thank you very much for reading the preview of the manual.
- You can download the complete manual from: www.heydownloads.com by clicking the link below



- Please note: If there is no response to CLICKING the link, please download this PDF first and then click on it.

CLICK HERE TO **DOWNLOAD** THE COMPLETE MANUAL