

LIEBHERR

CRAWLER CRANE

TECHNICAL INFORMATION

TYPE:

LR 1250

ORDER - NO.:

188 104

Subjekt to alteration !

Date

25.02.1999

Edition

1 (wh)

BAL no. / modification / chapter

8.104 /--- /---



CLICK HERE TO **DOWNLOAD** THE COMPLETE MANUAL

- Thank you very much for reading the preview of the manual.
- You can download the complete manual from: www.heydownloads.com by clicking the link below



- Please note: If there is no response to CLICKING the link, please download this PDF first and then click on it.

CLICK HERE TO **DOWNLOAD** THE COMPLETE MANUAL

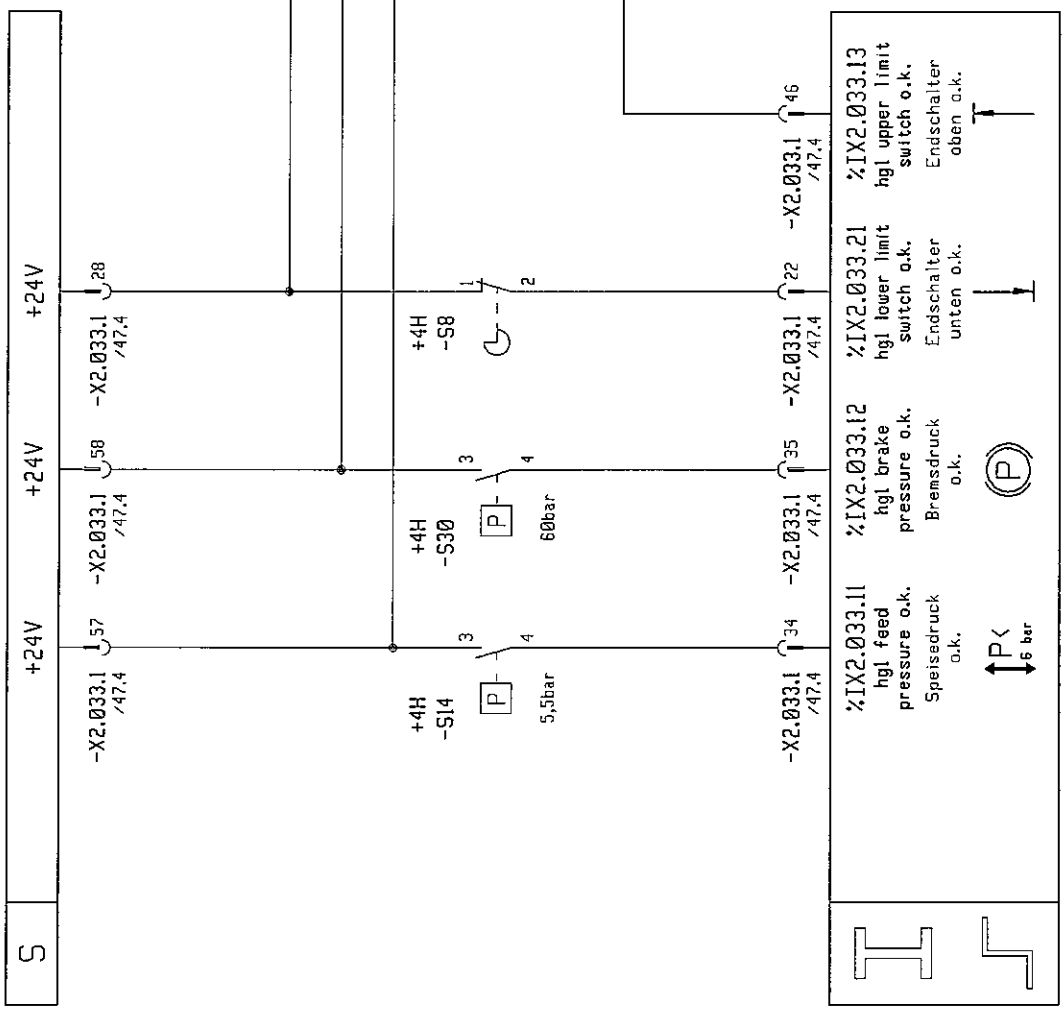

LIEBHERR-WERK NENZING GES.MBH A-6710 NENZING Copyright (c)	issued Erstellt	23.01.98	schaplima	name/Benennung INPUTS HOISTING GEAR I EINGÄNGE HUBWINDE I	drawing no.: Zeichnungs.Nr.	893 9000 06 0XX	OH 4R
	approved geprüft		Name/name	date	ident.no.: Idennummer:	970619303	Blatt/sheet 14 von/of 57
		Datum/date		schaplima 02	mod.no.:		
				name i. ind.			

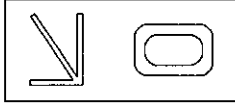
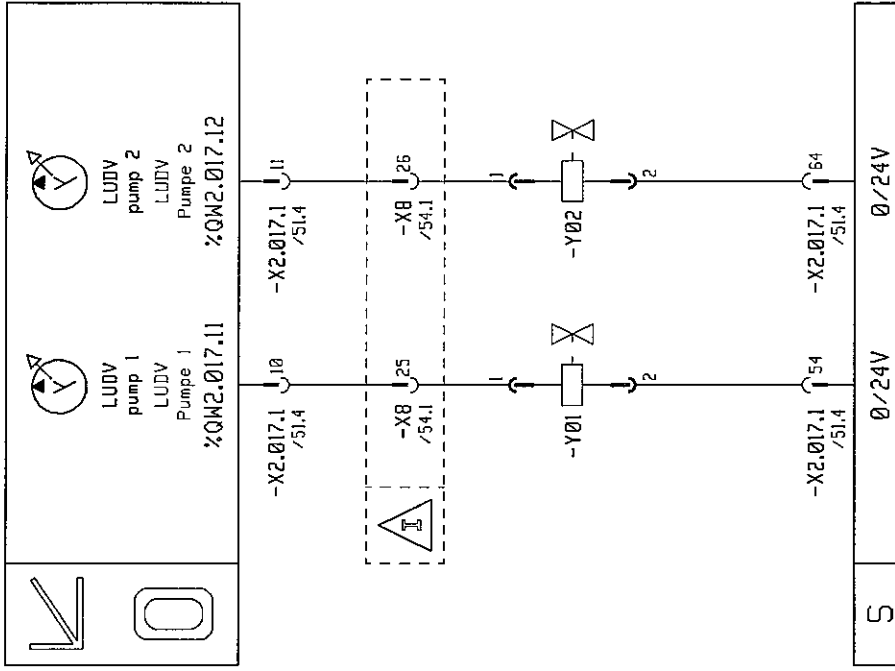

LUDV pump 1
LUDV Pumpe 1
%QW2.017.11

LUDV pump 2
LUDV Pumpe 2
%QW2.017.12

LIEBHERR-MERK NENZING GES.MBH A-6710 NENZING Copyright (c)	issued Erstellt	23.01.98	schaplma	name/Benennung OUTPUTS LUDV PUMP AUSGÄNGE LUDV PUMPE	drawing no.: 893 9000 06 0XX Zeichnungs.Nr. ident.no.: 73348 Identnummer:	= 0M + 4R Blatt/sheet 24 von/of 57
	approved geprüft	Date/Date	Name/Name	date : 26.06.98 date : 26.06.98		

LPF3/29.8
LPF4/6.4
LM/29.8

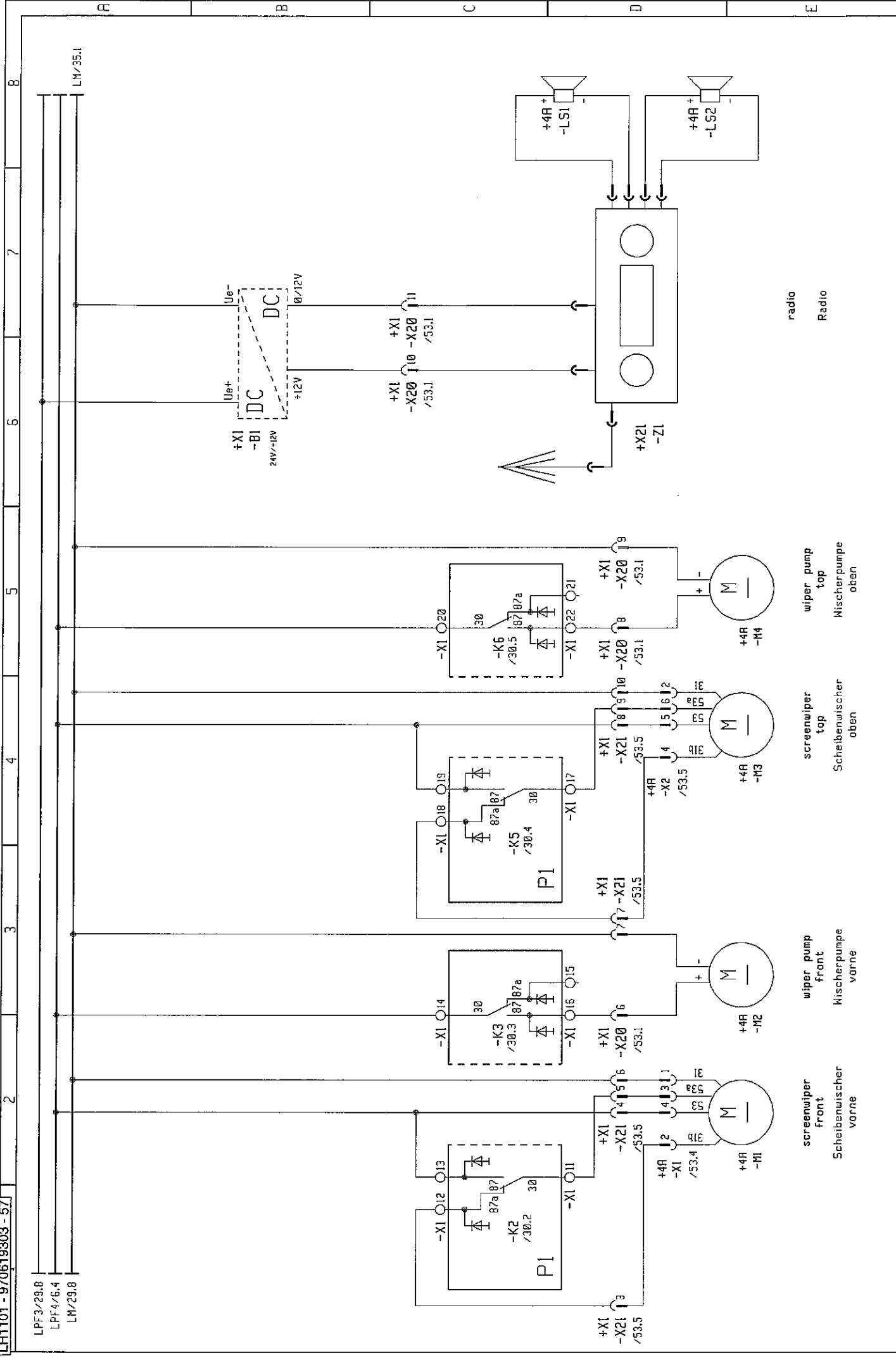

issued Erstellt	23.01.98	schapfma	name/Benennung					drawing no.:	893 9000 06 0XX	KB
approved geprüft			ELECTRIC CABIN					Zeichnungs-Nr.		P1
			ELEKTRIK KABINE					ident.no.:	970619303	Blatt/sheet 34
								date :		von/of 57
								name :		
								ind. mod.no.:		

modification index

revision 1	revision 2	revision 3	revision 4	revision 5	revision 6	revision 7	revision 8	revision 9	revision 10
date 25.02.98 mod.no: 72901 mod./pages	date 22.07.98 mod.no: 73480 mod./pages	date mod.no: mod./pages	date mod.no: mod./pages	date mod.no: mod./pages	date mod.no: mod./pages	date mod.no: mod./pages	date mod.no: mod./pages	date mod.no: mod./pages	date mod.no: mod./pages
1 3 5 6	1 3 4 6								

LIEBHERR-WERK NENZING GES.MBH		issued Erstellt	18.03.97	name/Benennung MODIFICATION INDEX ÄNDERUNGSINDEX		drawing no.: 0002 552 11 06 000 0XX	=
A-6710 NENZING Copyright (c)		approved geprüft		backmisch		Zeichnungs.Nr. 73480	+
			Datum/date	Name/name		ident.no.: 72901	Blatt/sheet 5
						date: name: / mod. / mod./mod.	von/of 6

A

B

C

D

E

CLICK HERE TO **DOWNLOAD** THE COMPLETE MANUAL

- Thank you very much for reading the preview of the manual.
- You can download the complete manual from: www.heydownloads.com by clicking the link below



- Please note: If there is no response to CLICKING the link, please download this PDF first and then click on it.

CLICK HERE TO **DOWNLOAD** THE COMPLETE MANUAL

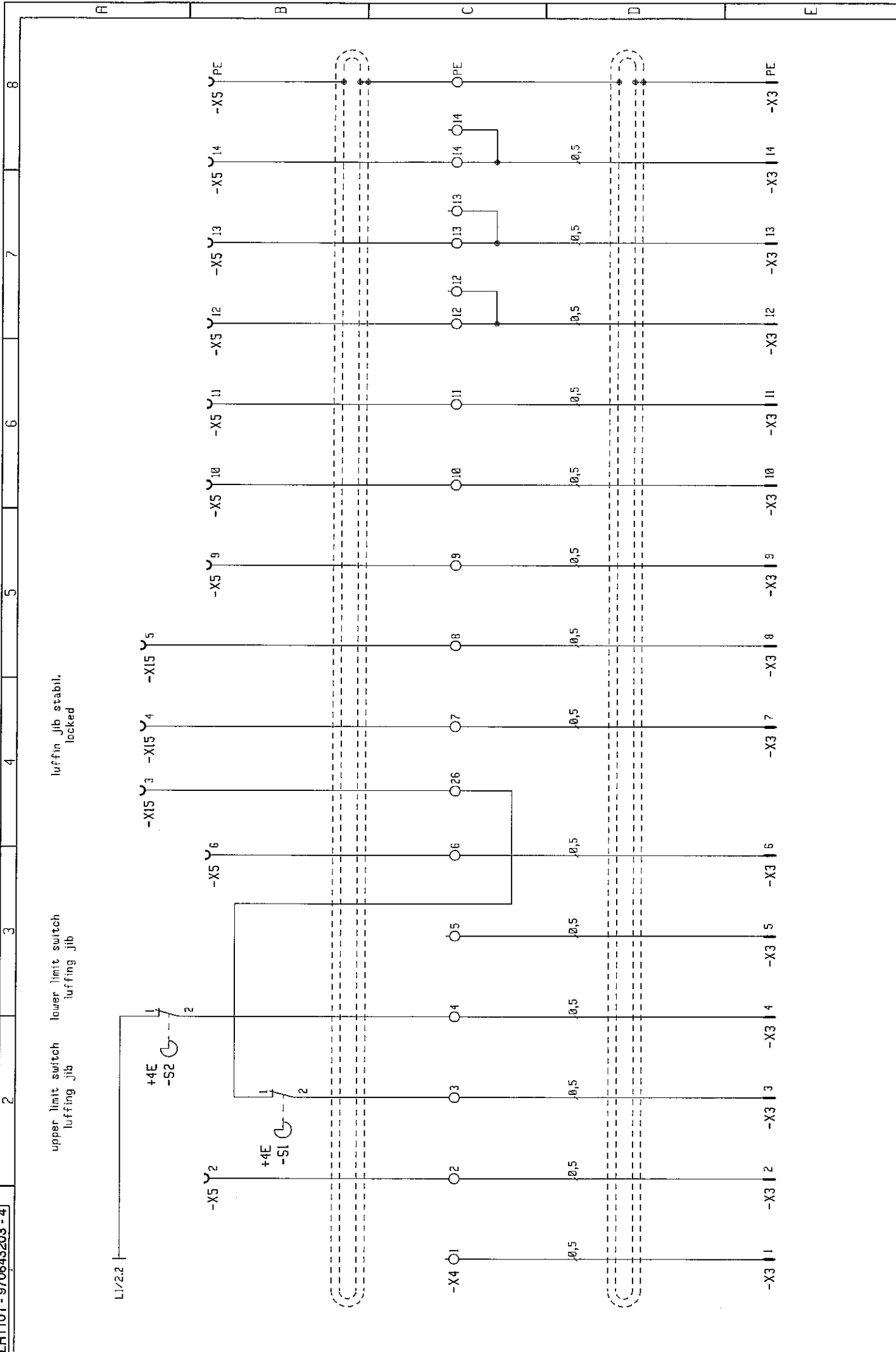

upper limit switch
luffing jib

lower limit switch
luffing jib

luffin_jib stabil.
locked

LIEBHERR-WERK NENZING GES.MBH		Issued Erstellt		17.09.97	schapima		name/Benennung		drawing no.:		503 073 9000 06 0XX	
A-6710 NENZING		approved geprüft			17.09.97		CIRCUIT DIAGRAM		Zeichnungs.Nr.		970643203	
Copyright (c)		Date/Date			17.09.97		STROMLAUFPLAN		Ident.no.:		970643203	
		Name/Name			schapima				mod.no.:		von/of	
		Date/Date			schapima				74369		4R	
		Name/Name			schapima				73164		3	
		Date/Date			schapima				73089		4	
		Name/Name			schapima				73089		4	
		Date/Date			schapima				73089		4	
		Name/Name			schapima				73089		4	
		Date/Date			schapima				73089		4	
		Name/Name			schapima				73089		4	
		Date/Date			schapima				73089		4	
		Name/Name			schapima				73089		4	
		Date/Date			schapima				73089		4	
		Name/Name			schapima				73089		4	
		Date/Date			schapima				73089		4	
		Name/Name			schapima				73089		4	
		Date/Date			schapima				73089		4	
		Name/Name			schapima				73089		4	
		Date/Date			schapima				73089		4	
		Name/Name			schapima				73089		4	
		Date/Date			schapima				73089		4	
		Name/Name			schapima				73089		4	
		Date/Date			schapima				73089		4	
		Name/Name			schapima				73089		4	
		Date/Date			schapima				73089		4	
		Name/Name			schapima				73089		4	
		Date/Date			schapima				73089		4	
		Name/Name			schapima				73089		4	
		Date/Date			schapima				73089		4	
		Name/Name			schapima				73089		4	
		Date/Date			schapima				73089		4	
		Name/Name			schapima				73089		4	
		Date/Date			schapima				73089		4	
		Name/Name			schapima				73089		4	
		Date/Date			schapima				73089		4	
		Name/Name			schapima				73089		4	
		Date/Date			schapima				73089		4	
		Name/Name			schapima				73089		4	
		Date/Date			schapima				73089		4	
		Name/Name			schapima				73089		4	
		Date/Date			schapima				73089		4	
		Name/Name			schapima				73089		4	
		Date/Date			schapima				73089		4	
		Name/Name			schapima				73089		4	
		Date/Date			schapima				73089		4	
		Name/Name			schapima				73089		4	
		Date/Date			schapima				73089		4	
		Name/Name			schapima				73089		4	
		Date/Date			schapima				73089		4	
		Name/Name			schapima				73089		4	
		Date/Date			schapima				73089		4	
		Name/Name			schapima				73089		4	
		Date/Date			schapima				73089		4	
		Name/Name			schapima				73089		4	
		Date/Date			schapima				73089		4	
		Name/Name			schapima				73089		4	
		Date/Date			schapima				73089		4	
		Name/Name			schapima				73089		4	
		Date/Date			schapima				73089		4	
		Name/Name			schapima				73089		4	
		Date/Date			schapima				73089		4	
		Name/Name			schapima				73089		4	
		Date/Date			schapima				73089		4	
		Name/Name			schapima				73089		4	
		Date/Date			schapima				73089		4	
		Name/Name			schapima				73089		4	
		Date/Date			schapima				73089		4	
		Name/Name			schapima				73089		4	
		Date/Date			schapima				73089		4	
		Name/Name			schapima				73089		4	
		Date/Date			schapima				73089		4	
		Name/Name			schapima				73089		4	
		Date/Date			schapima				73089		4	
		Name/Name			schapima				73089		4	
		Date/Date			schapima				73089		4	
		Name/Name			schapima				73089		4	
		Date/Date			schapima				73089		4	
		Name/Name			schapima				73089		4	
		Date/Date			schapima				73089		4	
		Name/Name			schapima				73089		4	
		Date/Date			schapima				73089		4	
		Name/Name			schapima				73089		4	
		Date/Date			schapima				73089		4	
		Name/Name			schapima				73089		4	
		Date/Date			schapima				73089		4	
		Name/Name			schapima				73089		4	
		Date/Date			schapima				73089		4	
		Name/Name			schapima				73089		4	
		Date/Date			schapima				73089		4	
		Name/Name			schapima				73089		4	
		Date/Date			schapima				73089		4	
		Name/Name			schapima				73089		4	
		Date/Date			schapima				73089		4	
		Name/Name			schapima				73089		4	
		Date/Date			schapima				73089		4	
		Name/Name			schapima				73089		4	
		Date/Date			schapima				73089		4	
		Name/Name			schapima				73089		4	
		Date/Date			schapima				73089		4	
		Name/Name			schapima				73089		4	
		Date/Date			schapima				73089		4	
		Name/Name			schapima				73089		4	
		Date/Date			schapima				73089		4	
		Name/Name			schapima				73089		4	
		Date/Date			schapima				73089		4	
		Name/Name			schapima				73089		4	
		Date/Date			schapima				73089		4	
		Name/Name			schapima				73089		4	
		Date/Date			schapima				73089		4	
		Name/Name			schapima				73089		4	
		Date/Date			schapima				73089		4	
		Name/Name			schapima				73089		4	
		Date/Date			schapima				73089		4	
		Name/Name			schapima				73089		4	
		Date/Date			schapima				73089		4	
		Name/Name			schapima				73089		4	
		Date/Date			schapima				73089		4	
		Name/Name			schapima				73089		4	
		Date/Date			schapima				73089		4	
		Name/Name			schapima				73089		4	
		Date/Date			schapima				73089		4	
		Name/Name			schapima				73089		4	
		Date/Date			schapima				73089		4	
		Name/Name			schapima				73089		4	
		Date/Date			schapima				73089		4	
		Name/Name			schapima				73089		4	
		Date/Date			schapima				73089		4	
		Name/Name			schapima				73089		4	
		Date/Date			schapima				73089		4	
		Name/Name			schapima				73089		4	
		Date/Date			schapima				73089		4	
		Name/Name			schapima				73089		4	
		Date/Date			schapima				73089		4	
		Name/Name			schapima				73089		4	
		Date/Date			schapima				73089		4	
		Name/Name			schapima				73089		4	
		Date/Date			schapima				73089		4	
		Name/Name			schapima				73089		4	
		Date/Date			schapima				73089		4	
		Name/Name			schapima				73089		4	
		Date/Date			schapima				73089		4	
		Name/Name			schapima				73089		4	
		Date/Date			schapima				73089		4	
		Name/Name			schapima				73089		4	
		Date/Date			schapima				73089		4	
		Name/Name			schapima				73089		4	
		Date/Date			schapima				73089		4	
		Name/Name			schapima				73089		4	
		Date/Date			schapima				73089		4	
		Name/Name			schapima				73089		4	

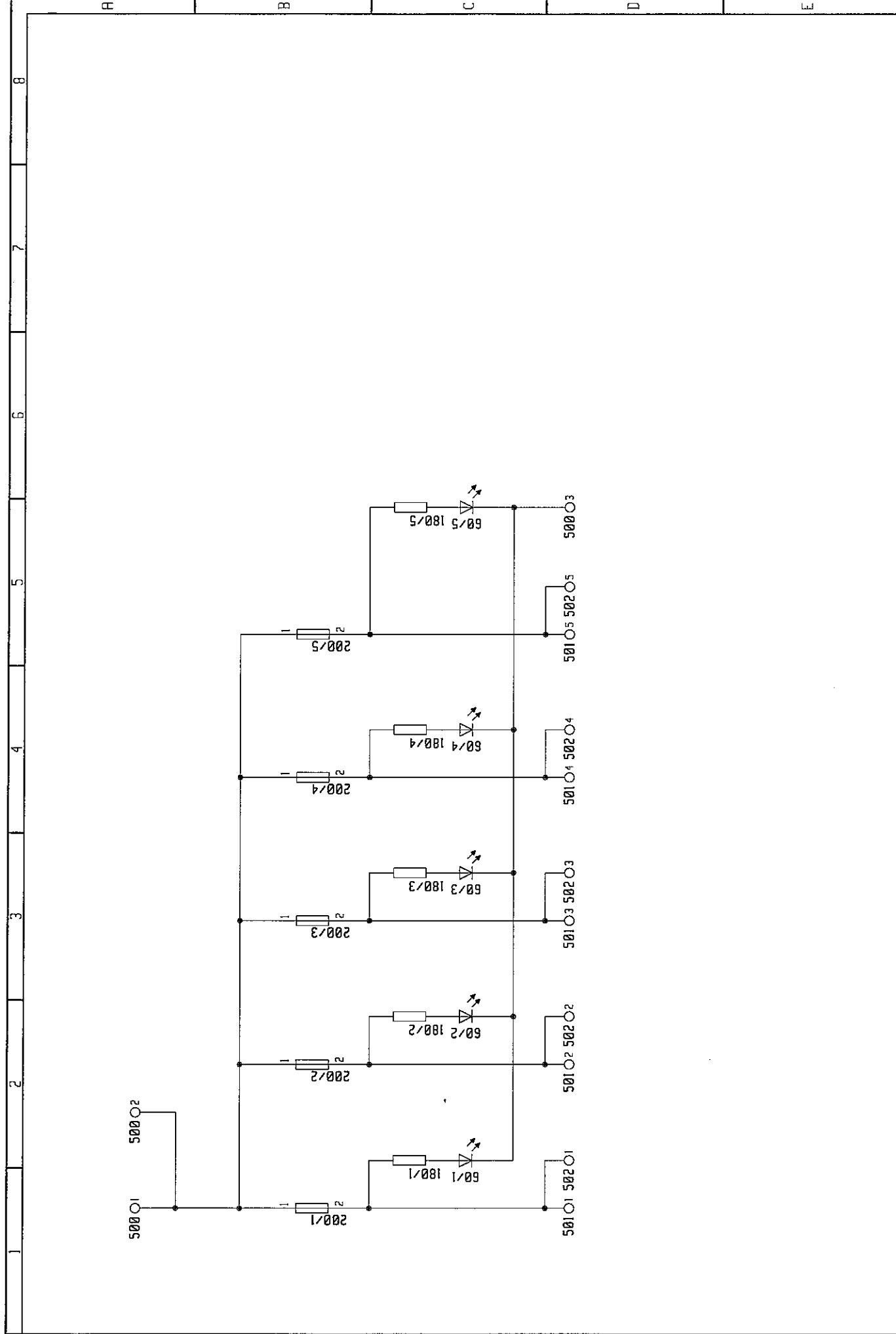

LIEBHERR-WERK NENZING GES.MBH		issued Erstellt	28.09.93	dur	name/Benennung	
A-6710 NENZING		approved geprüft			CIRCUIT DIAGRAM FUSE BOARD	
Copyright (c) 23-02-99 nenzing-werk					SCHALTPLAN SICHERUNGSLEISTE	
drawing no.: 0002 556 14 01 003 000					=	
Zeichnungs.Nr.					+	
ident.no.: 982405014					Blatt/sheet 1	
ident.no.:					von/of 1	
date:						
name:						
ind.:						
mod.no.:						

Can - Bus Blockdiagram

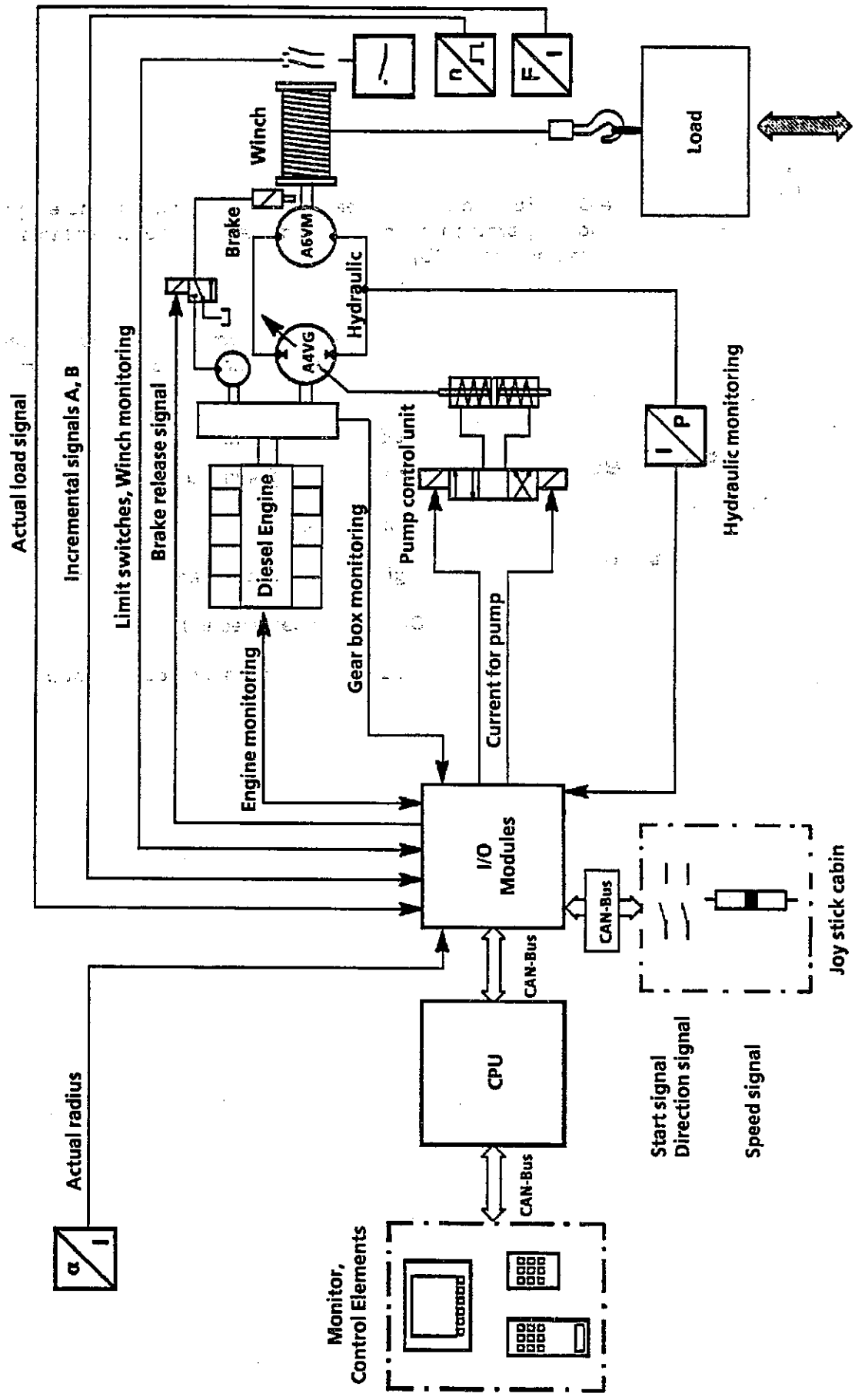

4. HYDRAULIC SYSTEM BASIC MACHINE

Name	Page	Drawing number	Date	Modification no.- / date
4.1 Arrangement and description of the hydraulic components	4.1 - 4.11	Fig. 1 - 19	98.03.11	-
4.2 Hydraulic super-structure	1 - 6	893 7000 01 007	97.09.23	73691/98.09.16
4.3 Hydraulic under-carriage	1/5, 4/5 5/5	893 7800 00 004	97.04.29	73691/98.09.16

ATTENTION !

All adjustments of the hydraulic system may only be carried out by trained LIEBHERR SERVICE PERSONNEL. There will be no guarantee for improper adjustments by other personnel.

Control for A - bock cylinder and hoisting cylinder

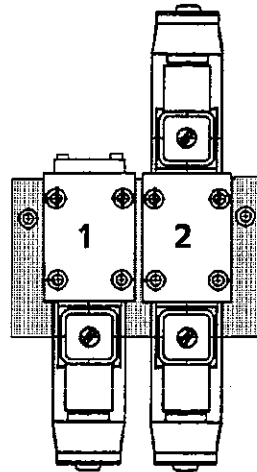

Fig. 16

- 1 = 4E - Y14 Control for A - bock cylinder with high pressure drive out
- 2 = 4A - Y71/Y72 Control for hoisting cylinder drive in / out

Control for A - bock cylinder

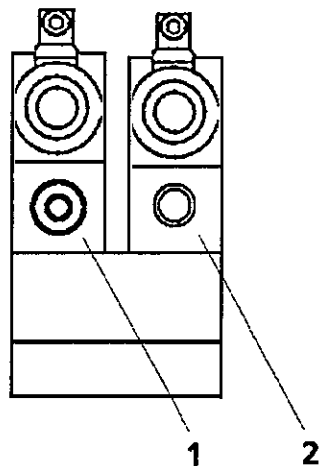
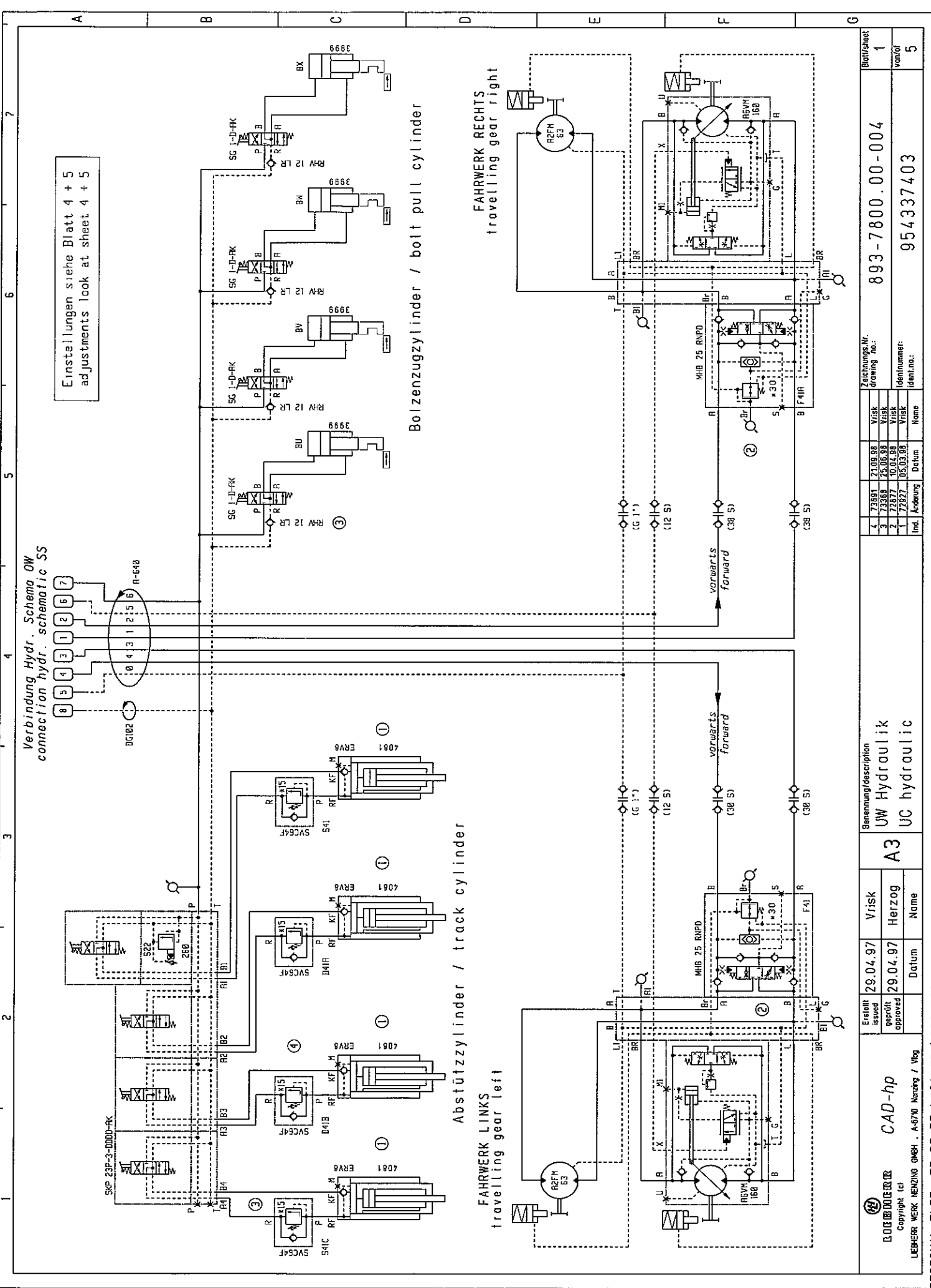

Fig. 17

- 1 = 4E - Y11/Y12 Control for A - bock cylinder drive in / out
- 2 = 4E - Y13 Control for A - bock cylinder with high pressure drive out



Einstellungen siehe Blatt 4 + 5
adjustments look at sheet 4 + 5

Verbindung Hydr. Schema OW
connection hydr. schematic SS

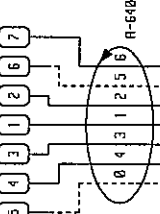

Bolzenzugzylinder / bolt pull cylinder

Abstützylinder / track cylinder

FAHRWERK LINKS
travelling gear left

FAHRWERK RECHTS
travelling gear right

		CAD-hp Copyright (c) LEBER WERK MENZING GMBH - A-6700 Neudorf / Vbg		Erteilt issued 29.04.97	geprüft approved 29.04.97	Vrisk Herzog	Name Name	Benennung/Description UW Hydraulik UC hydraulic	Zeichnungs-Nr. drawing no.: 893-7800.00-004	Blatt/Sheet 1 von/of 5
1	Ind.	1	72927	05.03.95	Detum	Name				
2	Änderung	1	72927	05.03.95	Detum	Name				
3	Vrisk	2	72877	10.04.98	Vrisk	Name				
4	Vrisk	3	73369	25.06.98	Vrisk	Name				
5	Vrisk	4	72691	21.09.98	Vrisk	Name				

1	2	3	4	5	6	7	8
<p>INDEX :</p> <p>1 CIRCUIT DIAGRAM</p> <p>4 MODIFICATION INDEX</p>							
<p>INHALTSVERZEICHNIS :</p> <p>STROMLAUFPLAN</p> <p>RENDERUNGSINDEX</p>							
<p>CRANE TYPE : HS893</p> <p>Krantyp :</p>							
<p>ORDER NO.:</p> <p>Auftragsnr.:</p>							
<p>CUSTOMER :</p> <p>Kunde :</p>							

INDEX :

- 1 CIRCUIT DIAGRAM
- 4 MODIFICATION INDEX

INHALTSVERZEICHNIS :

- STROMLAUFPLAN
- RENDERUNGSINDEX

CRANE TYPE : HS893

Krantyp :

ORDER NO.:

Auftragsnr.:

CUSTOMER :

Kunde :

LIEBHERR-WERK NENZING GES.MBH A-6710 NENZING Copyright (c)	issued Erstellt	17.09.97	zvoke/tra	name/Benennung	03.09.98	schaap/ma 04	73655	drawing no.:	509 135 9100 06 004	=
	approved geprüft			CIRCUIT DIAGRAM UPPER LIMIT SWITCH HD-HEAD	14.07.98	schaap/ma 03	73421	Zeichnungs.Nr.		+
				STROMLAUFPLAN ENDSCHALTER OBEN S-KOPF	05.05.98	schaap/ma 02	73164	ident.no.:	97071503	Blatt/sheet 1
					05.02.98	schaap/ma 01	72827	ident.no.:		von/of 4
				date :	name :	ind. mod.no.:				

6.5 ELECTRIC ROPE ENTRY WINCH 1.3 TO

Name	Page	Drawing number	Date	Modification no.- / date
Circuit diagram	1 - 3	520 224 9000 06 000	98.04.30	-

CLICK HERE TO **DOWNLOAD** THE COMPLETE MANUAL

- Thank you very much for reading the preview of the manual.
- You can download the complete manual from: www.heydownloads.com by clicking the link below



- Please note: If there is no response to CLICKING the link, please download this PDF first and then click on it.

CLICK HERE TO **DOWNLOAD** THE COMPLETE MANUAL