



# Technical Manual

CLICK HERE TO **DOWNLOAD** THE COMPLETE MANUAL

- Thank you very much for reading the preview of the manual.
- You can download the complete manual from: [www.heydownloads.com](http://www.heydownloads.com) by clicking the link below



- Please note: If there is no response to CLICKING the link, please download this PDF first and then click on it.

CLICK HERE TO **DOWNLOAD** THE COMPLETE MANUAL

## PRESTART CHECKS

Before starting the drill, inspect it to ensure it is ready to be put into operation. Failure to make such a routine check could result in unnecessary downtime. For example, an undetected oil leak could result in a dry gear case, which would lead eventually to excessive gear wear or destruction, seized bearings, or other mechanical problems. A few minutes spent inspecting the machine often results in considerable savings in time and machine efficiency. This inspection should be performed before each shift.

### OUTSIDE INSPECTION (Figure 1)

1. Check areas around and under the machine for signs of diesel fuel, oil, water or grease leaks. If diesel fuel leakage is noted, no matter how small, take remedial action immediately. If single droplets of oil, water or grease are noticed, leakage is minimal. Determine the source of the leak and make note of it on the log sheet. If pooling of oil, water or grease is noticed, determine the source and take remedial action immediately.
2. Inspect the crawler belts for broken or cracked pads, missing lock pins, loose track pins, and proper crawler belt tension.
3. Check the drive tumbler gearcase, hydraulic motor and hoses for leaks. Check the oil level in the drive tumbler gearcase.
4. Inspect the crawler frames for cracks and dirt or ice buildup. Check the rollers and tumblers for proper lubrication, free operation, and dirt or ice buildup. Check axle attachment pins and bolts.
5. Check the dust curtains for tears. Be sure that the curtains are not frozen to the ground or covered with cuttings.
6. Check the fuel tank and fuel lines for leaks. Repair any leaks found immediately. Any rusting found on the fuel tank should be noted and the area cleaned and repainted at the earliest opportunity.
7. Drain the air receiver of condensation. It is necessary to go underneath the machine to do this. At this time inspect the underside of the

machine for cracks, loose hoses or wires, dirt or ice accumulation, or other deterioration or damage. If loose wires are noted to not touch them but notify an electrician immediately.

8. Inspect the leveling jack spuds for proper grease covering. Inspect the leveling jack pads for cracks, broken or missing pins, or excessive dirt accumulation.
9. Inspect the mast braces and locking pins. Replace missing or defective components immediately. Verify that all adjusting bolts are properly adjusted. Check all hoses and cylinders for leaking.



**CAUTION: Use a safety belt and lanyard to protect against falls when climbing on the mast braces or working on the machinery house roof.**

10. Inspect the mast hinge pins for loose or missing keepers or bolts. Replace missing or damaged parts immediately. Check the pins for sufficient lubrication and lubricate if necessary.
11. Inspect the mast hoist cylinders for loose or missing pins or keepers, oil leaks, damaged hoses or structural damage. Repair or replace any missing or damaged components immediately.
12. Inspect the mast structure for bent or broken chords or plates, loose or broken parts, proper rack lubrication or excessive rack wear. Inspect ladders, handrails and platforms for broken or missing parts. Repair or replace broken or missing parts immediately.
13. Check the main air flex hose, lubrication lines, and electric lines running from the mast to the rotary drive/pulldown unit for interference with the mast or excessive wear or leaks.
14. Check the safety restraint cables on the mast. Be certain that the cables and supports are in good repair with no cracks, missing or loose hardware or any damage that could affect their effectiveness.
15. Every 160 hours inspect and lubricate the upper auxiliary winch sheaves. All pins, keepers and hardware should be secured.

## INDICATOR LIGHTS PANEL (Figure 9)

The indicator lights panel consists of various red and green lights. The green indicator lights will normally be on and indicate that this function is activated and operating normally. The light will go out if a problem arises.

The red indicator lights will normally be out and will come on flashing only when an abnormal condition is present, such as an overload condition of a motor, ground fault, high air or oil temperature, etc. Pressing the alarm silence pushbutton will silence the alarm and stop the light from flashing but the red light will not go out until the problem is corrected.

Refer to figure 9 for the function of the machine that the indicator lights monitor.

## LEVELING CONTROL PANEL (Figure 10)

The leveling control panel consists of a circular type level used to determine machine levelness and four two-directional joysticks, one for each leveling jack cylinder. Moving the joystick forward (EXTEND position) will extend the jack cylinder and raise the machine. Pulling the joystick to the rear towards you (RETRACT position) will cause the leveling jacks to retract lowering the machine.

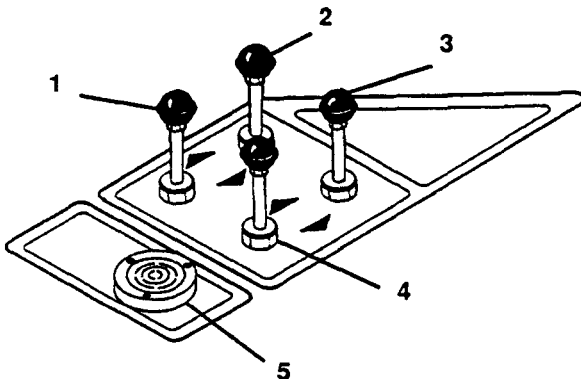

1. LEFT REAR LEVELING JACK JOYSTICK
2. LEFT FRONT LEVELING JACK JOYSTICK
3. RIGHT FRONT LEVELING JACK JOYSTICK
4. RIGHT REAR LEVELING JACK JOYSTICK
5. CIRCULAR TYPE LEVEL INDICATOR

LEVELING CONTROL PANEL  
FIGURE 10

These controls are for manual leveling of the machine and are not used when the machine is leveled automatically.

**NOTE: The joysticks should be moved in pairs. Single joysticks may be used for the finite finale adjustment of leveling jacks. All four leveling jack joysticks should not be moved at the same time.**

## DIESEL GAUGES PANEL (Figure 11)

The diesel gauges panel consists of four gauges on the right side of the panel which monitor the elements of the diesel and main compressor air filters. The gauges on the right side of the panel monitor the vital signs of the diesel engine (i.e. oil, water, fuel, etc.). Also included on the right side of the panel is a switch to light up the gauges.

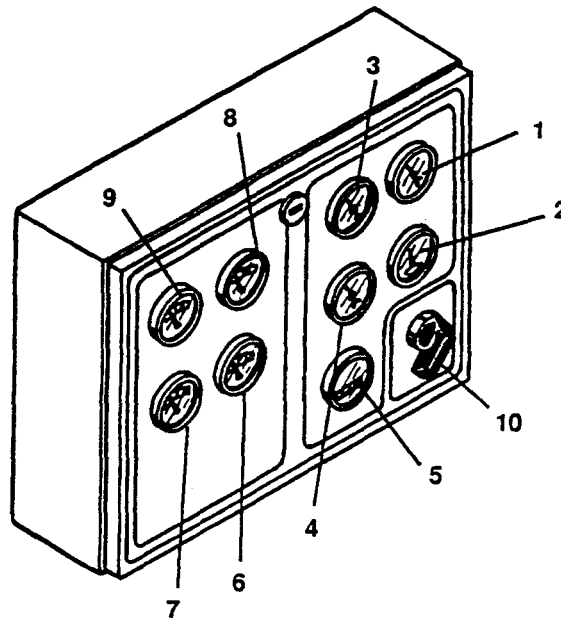

1. DIESEL WATER TEMPERATURE GAUGE
2. DIESEL FUEL LEVEL GAUGE
3. DIESEL OIL PRESSURE GAUGE
4. DIESEL VOLTMETER GAUGE
5. DIESEL HOURMETER
6. DIESEL RIGHT AIR FILTER GAUGE
7. DIESEL LEFT AIR FILTER GAUGE
8. MAIN COMPRESSOR RIGHT AIR FILTER GAUGE
9. MAIN COMPRESSOR LEFT AIR FILTER GAUGE
10. GAUGE LIGHT SWITCH

DIESEL GAUGES PANEL  
FIGURE 11

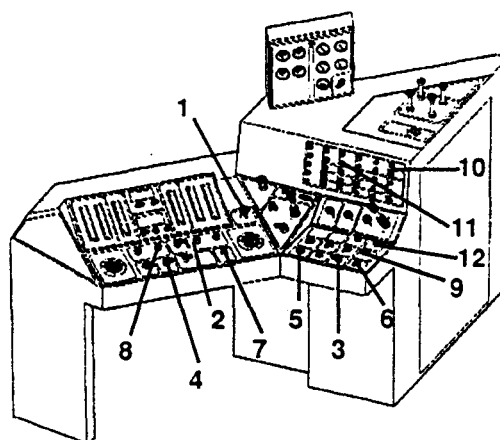
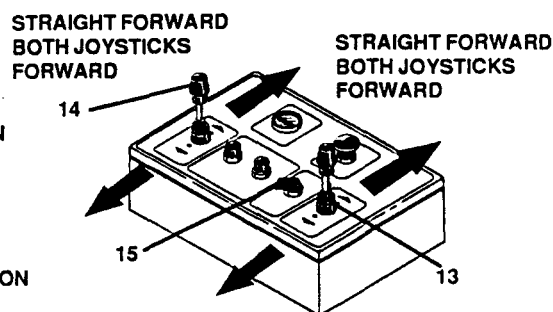
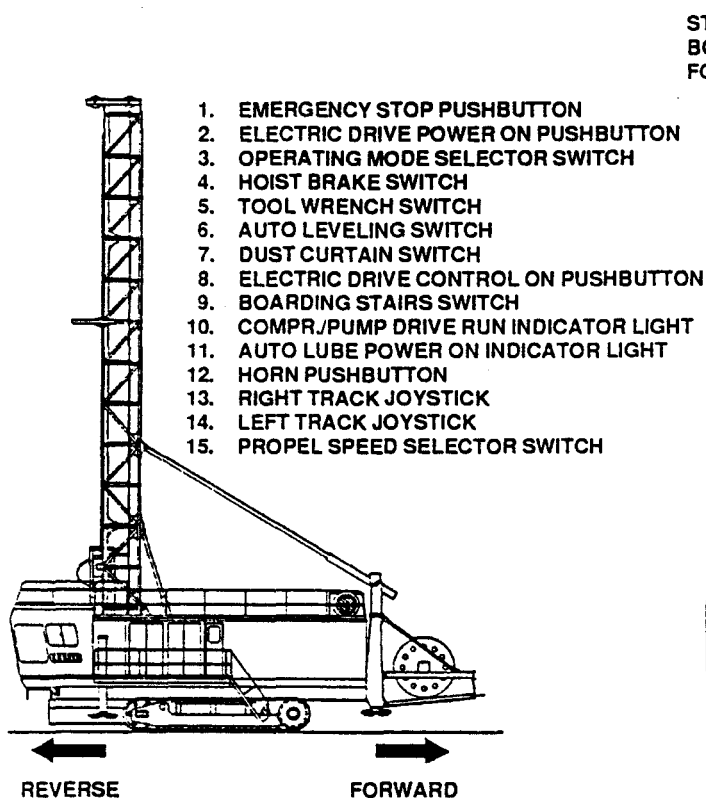

STRAIGHT PROPEL  
FORWARD OR REVERSE  
FIGURE 22

When the operator becomes more proficient or when moving from one sight to another, the increased speed of normal propel is used.

5. To propel straight forward move both joysticks slowly forward. Speed is increased as the levers are moved forward (figure 22). To propel straight in reverse pull both joysticks slowly to the rear. Speed is increased as the levers are pulled.
6. To make a gradual forward right turn, leave the right joystick in neutral and operate the left joystick forward (figure 23).
7. To make a gradual forward left turn, leave the left joystick in neutral and operate the right joystick forward (figure 24).
8. Gradual turns should be done in steps of 15 degrees each (figure 25). After turning the machine a maximum of 15 degrees, the machine should be propelled straight for about one-half of the length of the machine to clear

the crawler belts of dirt and rocks. Turning the drill in more than 15 degree increments will subject the crawler belts to severe strain.

9. To make a sharp right turn, push the left joystick forward and pull the right joystick to the rear (figure 26).
10. To make a sharp left turn, push the right joystick forward and pull the left joystick to the rear (figure 27).

**WARNING:** The ability of the machine to turn sharply is dependent on the surface on which the machine is setting. A soft surface will cause the crawlers to dig in and machine to bog down.

**WARNING:** For the remote propel station in the operator's cab, the propel brakes are released when the control "ON" pushbutton on the remote station is pressed. The brakes are set when the control "OFF" pushbutton is pressed.

Refer to the appropriate topic in this manual for the exact operating procedures.

2. Obtain a crane with suitable capacity and reach to place the drill pipe into the pipe racks with the mast in the stored position. Normal placement of the crane is on the left side of the drill since this allows the shortest reach and greatest boom angle.

**CAUTION:** Follow all applicable safety measures when working with cranes rigging. Failure to follow safe working procedures can cause an accident, leading to the possible death or injury of personnel.

3. Position the pipe to be installed in such a position so as to be accessible to the crane. Normal placement of the drill pipe is on the left side of the machine, laying at right angles to the machine. This allows the crane to lift the pipe and swing without excessive boom hoisting and lowering. The pipe may be stored on suitable blocking on the ground, or on a truck or trailer.

**CAUTION:** Make sure the drill pipe is secured against unwanted or unexpected movement. Failure to secure the pipe properly may result in the pipe shifting and causing death or serious injury to personnel in the area.

4. The upper gate is open when the pipe rack is empty. This function is controlled by a limit switch in the lower pocket of the pipe rack.
5. Using suitable rigging, attach the crane to the drill pipe. The pipe should be rigged so that it will remain horizontal while being lifted. Attach suitable tag lines to the pipe. Remove the thread protectors and clean and lubricate the threads and shoulders on each end of the pipe. Install an approved lifting bell to the pin (upper) end of the pipe. Lift the pipe into position over the mast.
6. Using a tag line guide the pipe into the desired pipe rack. Place suitable blocking beneath the pipe to allow the sling to be removed from the pipe.

**CAUTION:** Block the pipe securely to prevent it from moving unexpectedly.

7. Remove the slings from the pipe. Attach a sling to the lifting bell on the pin end of the pipe and lift the pipe sufficiently to remove the blocking.
8. Slide the pipe down the pipe rack until it rests on the bottom of the pocket. Lay the pipe in the pipe rack and remove the sling and lifting bell.

9. When the pipe rest in the bottom of the pocket it will trigger the limit switch and close the upper gate.
10. Repeat the procedure for additional lengths of pipe.
11. Unloading the pipe is the reverse of the procedure used for loading the pipe.

### DRILL TOOL STRING ASSEMBLY (Figure 36)

The tool string consists of one or more sections of drill pipe, a stabilizer (drill collar) and a bit. In assembling the tool string, the stabilizer is the first item installed, then comes the drill pipe and finally the bit.

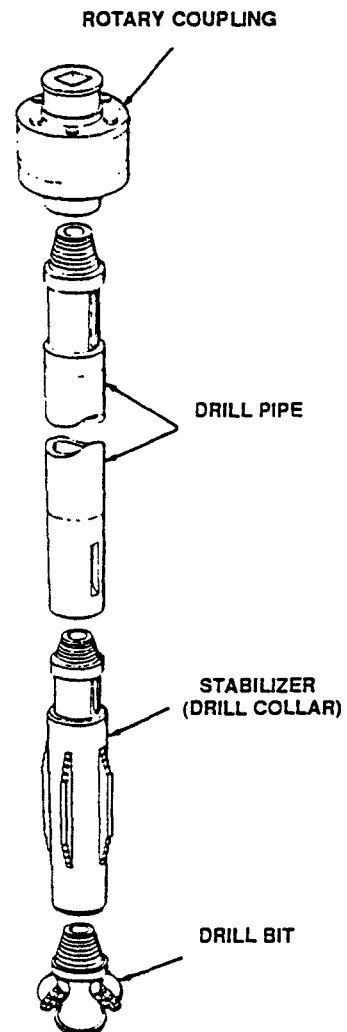
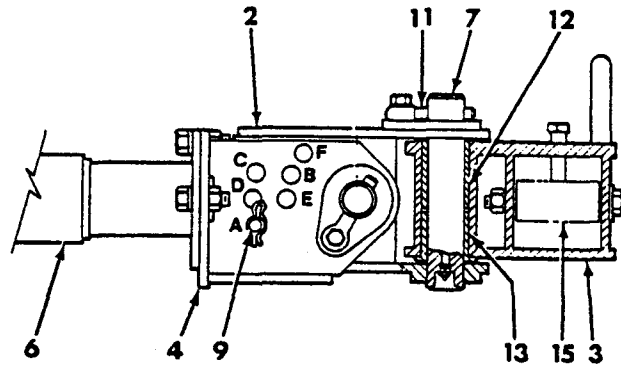
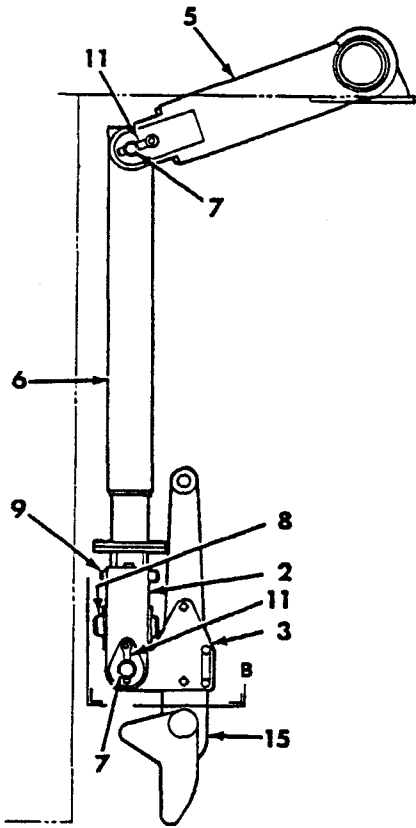
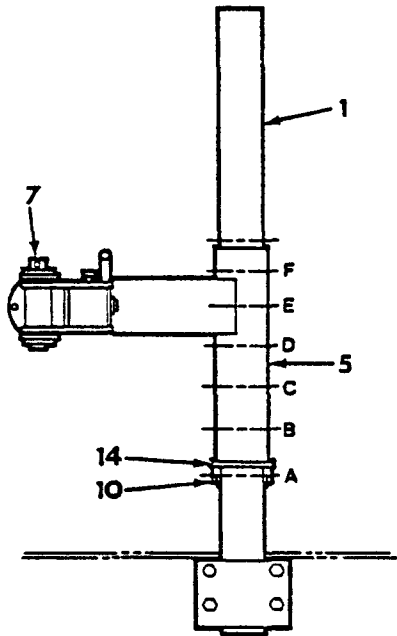

FIGURE 36



SECTION B

PIN HOLE	MAST ANGLE
A	0°
B	5°
C	10°
D	15°
E	20°
F	25°
C & G	30°



CASING TONG SUPPORT  
FIGURE 46

The procedure listed here is an outline intended only to give a general idea of the effort involved in proper storage of the machine. To store the unattended machine for an extended period of time, proceed as follows:

1. Complete all short term storage procedures.
2. Remove the motors from the drill and store in a heated building.
3. Completely fill the rotary and pulldown gear bases with an approved oil. Both cases can be filled completely by adding the oil through the breather openings. Remove all water from the cases.
4. Loosen the guide rollers on the rotary/pulldown unit frame to provide one-half inch clearance between the rollers and the mast.
5. Remove the auxiliary winch line.
6. Cover the rotary gear case and hoist/pulldown gear case with a waterproof tarp.
7. Remove the main air compressor from the machine and store in an attended heated building.
8. Close and completely seal all electrical cabinets.
9. Close and completely seal the operator's cab.
10. Close and completely seal the machinery house. Completely seal the filter fan unit.
11. Completely drain the compressor coolant system.
12. Remove the auxiliary air compressor from the machine and store in an attended building.
13. Propel the machine onto blocks to prevent the crawler belts from rusting. Coat the entire crawler belts with a rust preventative oil. Coat the propel chains with a rust preventative oil.
14. Block the leveling jacks in the full retracted position.
15. Manually grease every lube point (including auto lube points).

CLICK HERE TO **DOWNLOAD** THE COMPLETE MANUAL

- Thank you very much for reading the preview of the manual.
- You can download the complete manual from: [www.heydownloads.com](http://www.heydownloads.com) by clicking the link below



- Please note: If there is no response to CLICKING the link, please download this PDF first and then click on it.

CLICK HERE TO **DOWNLOAD** THE COMPLETE MANUAL