

Powered pallet truck MPL 16 D

Valid for machine number: 319481AM-

Only valid for machine number:

--	--	--	--	--	--	--	--	--	--

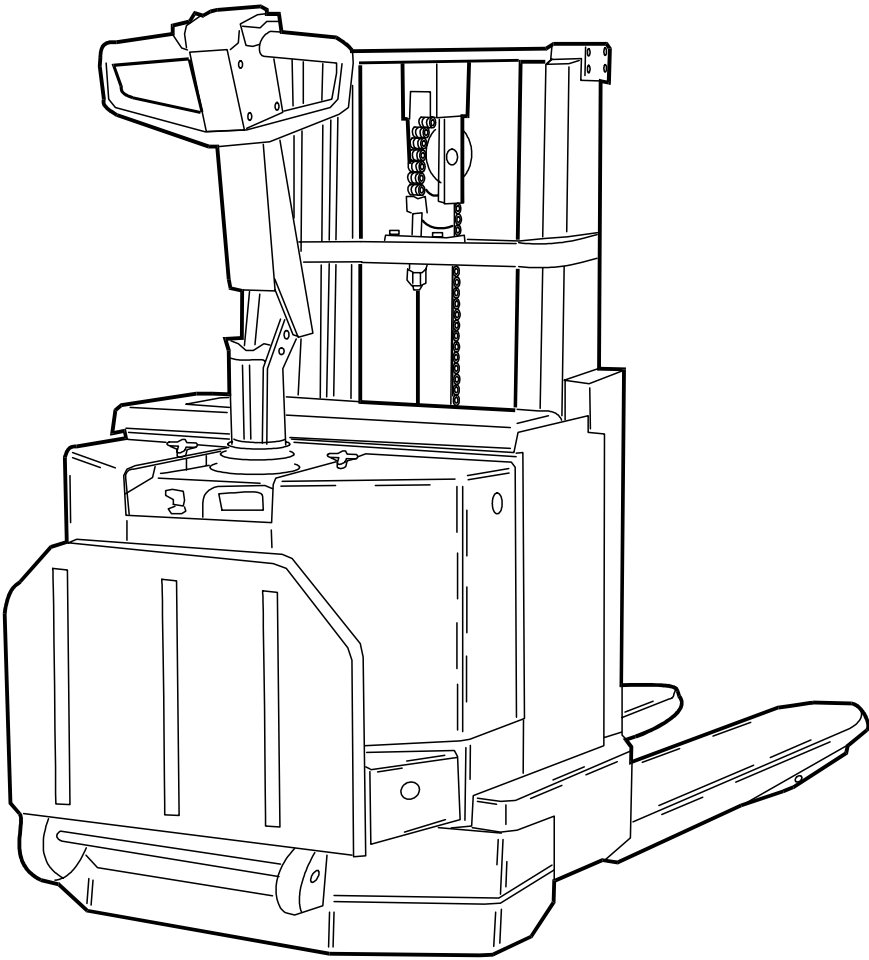
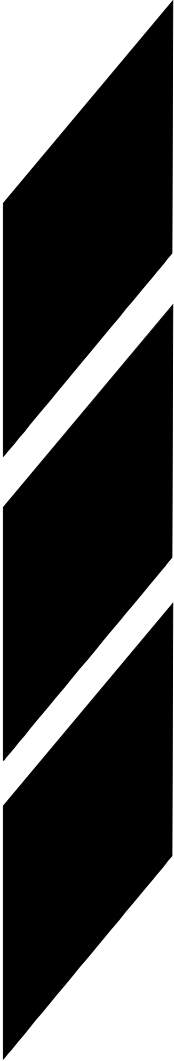

Spare Parts Catalogue

Ordering number 163535

Date 1998-05-19 / BDJ

CLICK HERE TO **DOWNLOAD** THE COMPLETE MANUAL

- Thank you very much for reading the preview of the manual.
- You can download the complete manual from: www.heydownloads.com by clicking the link below



- Please note: If there is no response to CLICKING the link, please download this PDF first and then click on it.

CLICK HERE TO **DOWNLOAD** THE COMPLETE MANUAL

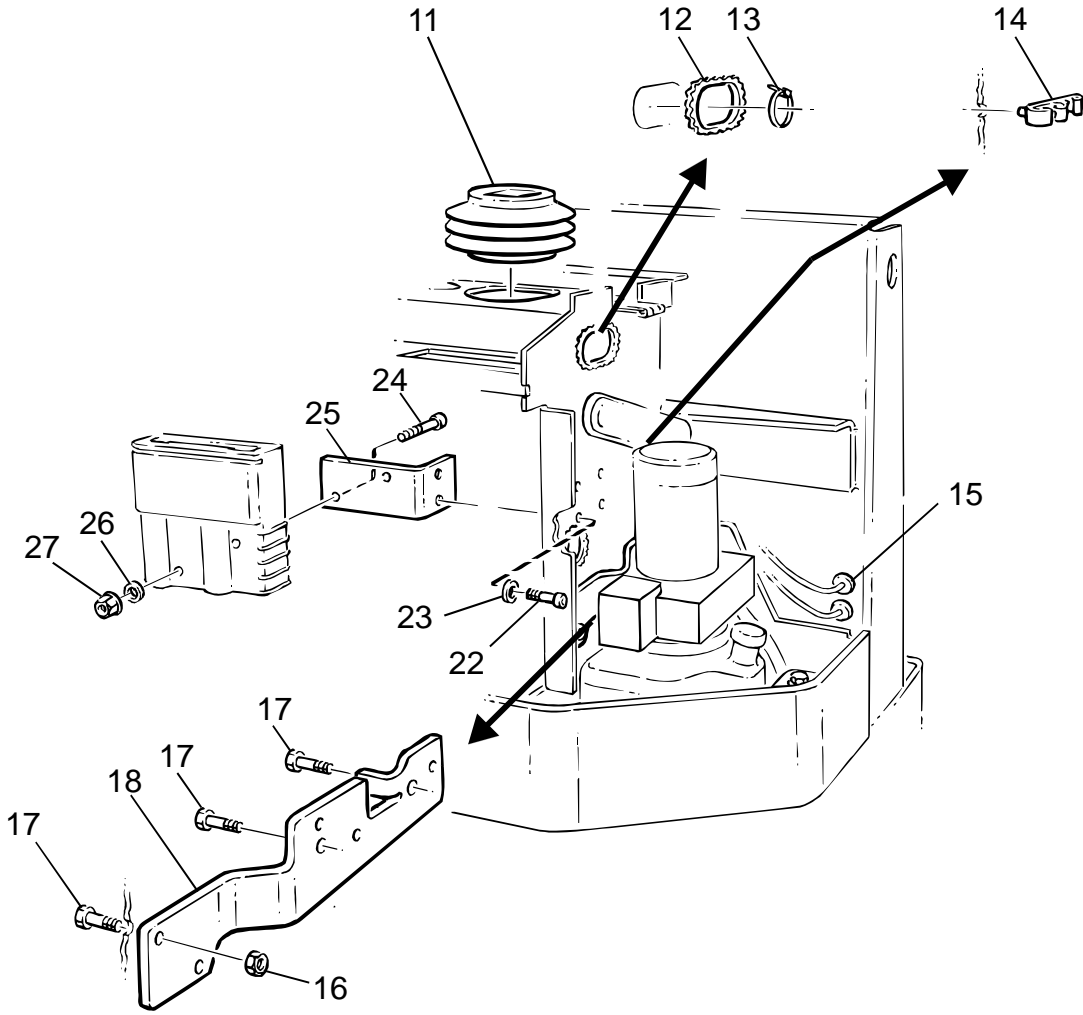

0850-072 Signs, warnings

[1998-05-19]

Skyltar, varningar; Schilder, Warnzeichen; Vignette, avertissement

			453 MPL 16D	319481 -
Pos	Description	Pcs	Part No	Note
11	Sign Skylt; Schild; Vignette	1	160524	
14	Sign Skylt; Schild; Vignette	1	148227	
15	Sign Skylt; Schild; Vignette	2	147316	
16	Sign Skylt; Schild; Vignette	2	152027	
17	Sign(" MPL 16 D ") Skylt; Schild; Vignette	2	157083-017	
18	Sign Skylt; Schild; Vignette	1	72082	
19	Sign Skylt; Schild; Vignette	1	148226	
20	Sign(" MOVIT ") Skylt; Schild; Vignette	2	144454	
21	Plate Plåt; Platte; Plaque	1	164233	

3530-012

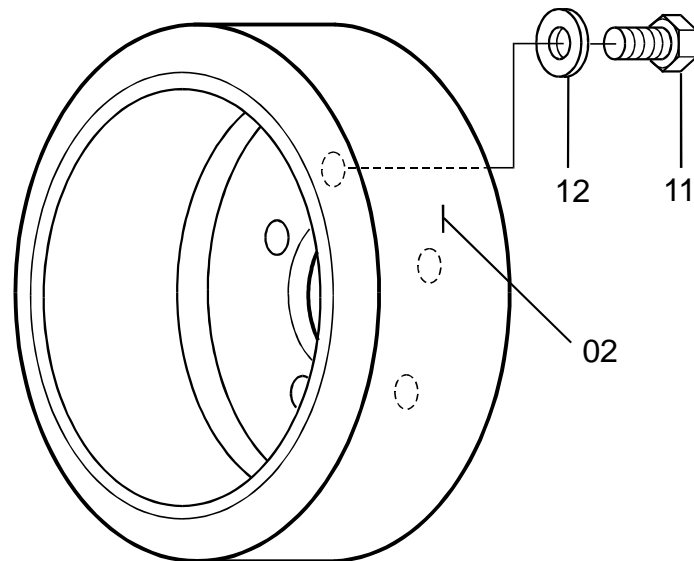

3530-012 Drive wheel

Drivhjul; Antriebsrad; Roue motrice

[1997-03-11]

			453 MPL 16D	296773 -
Pos	Description	Pcs	Part No	Note
02	Drive wheel(Tractothan) Drivhjul; Antriebsrad; Roue entrainement	1	143308	
02	Drive wheel(Rubber) Drivhjul(Gummi); Antriebsrad(Gummi); Roue entrainement(Gomme)	1	147214	
11	Screw Skruv; Schraube; Vis	5	110803	
12	Washer Bricka; Scheibe; Rondelle	5	21393	

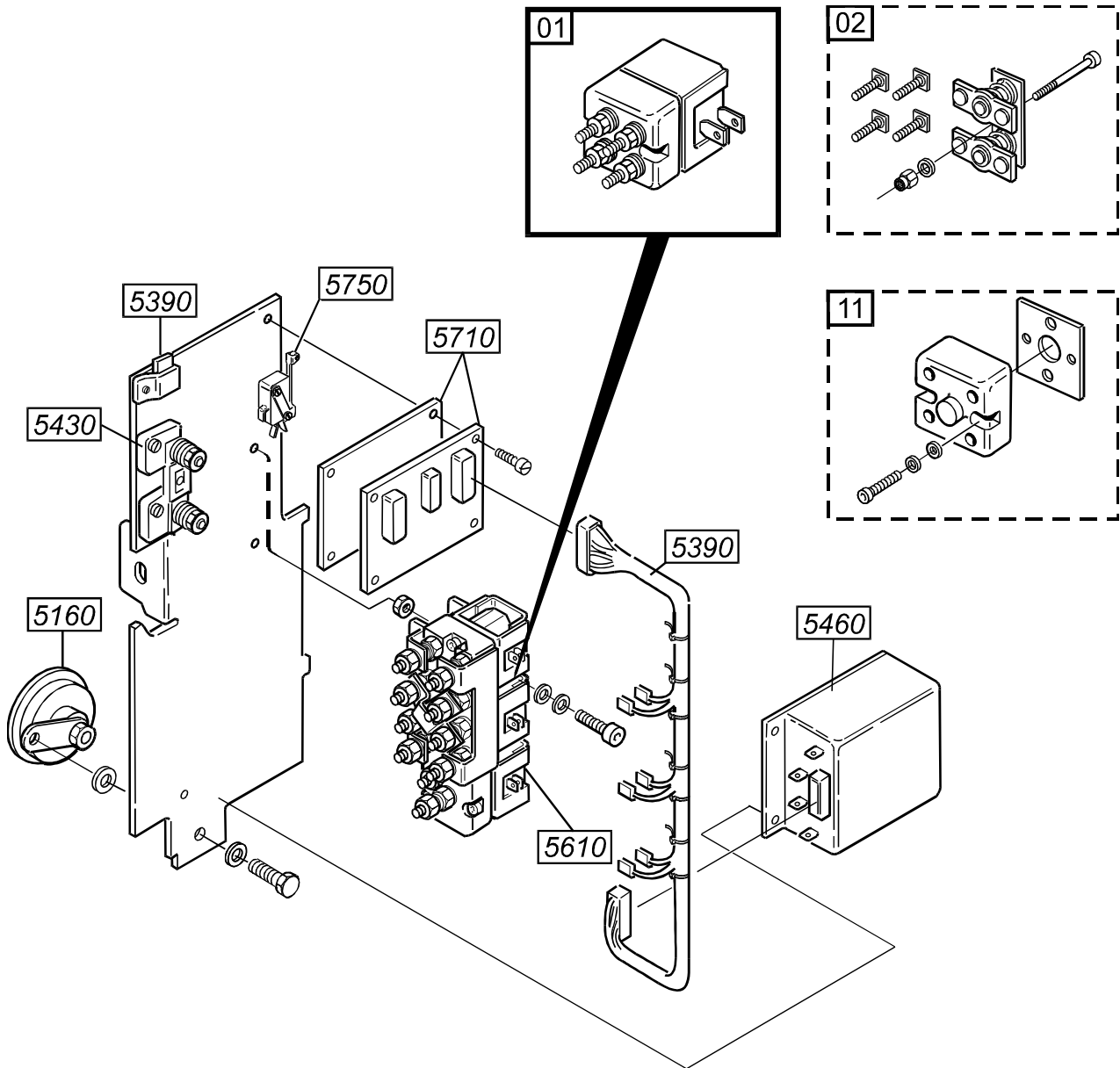

5440-006 Direction contactors

Riktningsskottor; Richtungsschütze; Contacteurs de direction

[1996-11-20]

Pos	Description	Pcs	Part No	Note
01	Contacteur Kontaktör; Kontaktör; Contacteur	2	135653	
02	Contact set Kontaktsats; Kontaktsats; Jeux de contact	2	135625	
11	Isulator kit Isolationssats; Isolationssats; Jeux de isolant	2	135623	

CLICK HERE TO **DOWNLOAD** THE COMPLETE MANUAL

- Thank you very much for reading the preview of the manual.
- You can download the complete manual from: www.heydownloads.com by clicking the link below



- Please note: If there is no response to CLICKING the link, please download this PDF first and then click on it.

CLICK HERE TO **DOWNLOAD** THE COMPLETE MANUAL