

SW770

SHOP MANUAL

SAKAI®

3498-6431A-0

CLICK HERE TO **DOWNLOAD** THE COMPLETE MANUAL

- Thank you very much for reading the preview of the manual.
- You can download the complete manual from: www.heydownloads.com by clicking the link below



- Please note: If there is no response to CLICKING the link, please download this PDF first and then click on it.

CLICK HERE TO **DOWNLOAD** THE COMPLETE MANUAL

10. TROUBLESHOOTING

1. TROUBLESHOOTING

- 1-1. Safety Precautions for Troubleshooting 10-001
- 1-2. Important Information for Troubleshooting 10-001
- 1-3. Before Starting 10-002

2. ELECTRICAL SYSTEM TROUBLESHOOTING

- 2-1. When Performing Electrical System Fault Diagnosis 10-003
 - 2-1-1. Precautions to take during electrical circuit fault diagnosis 10-003
 - 2-1-2. Inspection procedures using a tester 10-004
 - 2-1-3. Inspection of electrical system 10-009
- 2-2. Engine Diagnosis Trouble Code 10-011
 - 2-2-1. Description of diagnostic trouble code (DTC) 10-011
 - 2-2-2. Table of the diagnostic trouble code (DTC) 10-013
- 2-3. Vibration Error Lamp (SW770HF, SW770ND) 10-016
- 2-4. Engine 10-018
 - 2-4-1. Engine will not start (Starter motor does not run) 1/3 10-018
 - 2-4-1. Engine will not start (Starter motor does not run) 2/3 10-020
 - 2-4-1. Engine will not start (Starter motor does not run) 3/3 10-022
 - 2-4-2. Engine will not start (But starter motor runs) 10-024
 - 2-4-3. No charging 10-026
 - 2-4-4. Glow plug is not heated
(Engine starting performance is bad in cold weather) 10-026
 - 2-4-5. Engine speed cannot be switched 10-028
 - 2-4-6. Starter motor runs even when F-R lever is not at "N" and
parking brake is not applied 10-028
- 2-5. Propulsion 10-030
 - 2-5-1. Machine moves neither forward nor backward 1/3 10-030
 - 2-5-1. Machine moves neither forward nor backward 2/3 10-032
 - 2-5-1. Machine moves neither forward nor backward 3/3 10-034
 - 2-5-2. Machine speed cannot be changed 10-034
 - 2-5-3. Brake does not work 10-036
- 2-6. Vibration 10-038
 - 2-6-1. No vibration occurs 1/4 10-038
 - 2-6-1. No vibration occurs 2/4 10-040
 - 2-6-1. No vibration occurs 3/4 10-042
 - 2-6-1. No vibration occurs 4/4 10-044

1-10. Maintenance

- In any performing any work concerning the operation, adjustment or modification of the machine or it's safety devices or any work related to maintenance, inspection or repair, always follow the start-up and shut-down procedures in the Operator's Manual and the Maintenance Manual.
- Ensure that the maintenance area is safe and secure.
- If the machine is shut down for maintenance or repair work it must be secured against inadvertent starting by removing the starter key and attaching a warning sign to the starter switch.
- The machine must be parked on stable and level ground with the drums or tires blocked to prevent inadvertent movement.
- Immediately after the engine has stopped, the exhaust system, engine, radiator coolant, engine oil, hydraulic fluid and other lubricants and components will be very hot. Fluids can be under pressure, removing the radiator cap or draining oil or changing filters can cause serious burns. Wait until the machine has cooled down.
- Use care when attaching and securing lifting tackle to individual parts and large assemblies being removed or repositioned for repair purposes to avoid the risk of accident. Use lifting devices that are in perfect condition and of sufficient lifting capacity. Never stand under suspended loads.
- Always use the proper tools and workshop equipment in good condition when performing maintenance or repairs on the machine.
- Always use specially designed safety ladders and working platforms when working above floor level. Never use machine parts as a climbing aid.
- Keep all steps, handles, handrails, platforms and ladders free from mud, dirt, grease, ice or snow.
- Clean the machine, especially threaded connections of any traces of oil or fuel before carrying out any maintenance or repairs. Never use aggressive detergents. Use lint free cleaning rags.
- Examine all fuel, lubricant and hydraulic fluid lines and connectors for leaks, loose connections chafe marks or damage after cleaning.
- Repair or replace defective parts immediately.
- Whenever possible, avoid servicing or maintenance when the engine is running unless the drums or tires are adequately blocked, the articulation lock bar is in the locked position and the parking brake is applied.
- Never fill the fuel tank with the engine running, while near an open flame or while smoking. Always clean up any spilled fuel.
- Ensure safe operation, optimum performance of the machine and its warranty by using only genuine SAKAI replacement parts.

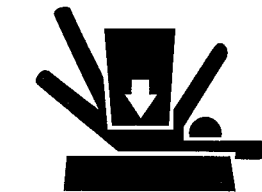

SPECIFICATIONS

Engine	Name		ISUZU 4JJ1XDIA Diesel Engine (EPA Tier 3) with turbocharger		
	Model		4-cycle, water-cooled, 4-cylinder in-line, overhead camshaft, vertical in-line, direct injection type, with turbocharger		
	Bore × Stroke		95.4 mm × 104.9 mm (3.756 in. × 4.130 in.)		
	Displacement		2.999 L (183 cu.in)		
	Performance (SAE NET)	Rated speed		2,200 min ⁻¹	
		Rated output		92 kW (123 HP)	
		Max. torque		420 N·m (310 lbf·ft) at 1,800 min ⁻¹	
		Fuel consumption		206 g/kW·h (0.339 lb/HP·h) at rated speed with silencer and air cleaner, without cooling fan	
	Fuel injection system		Full electronic control		
	Fuel injection pump		Common rail HP3 type		
	Lubrication system		Full forced pressure feed type		
	Oil filter		Full flow paper element		
	Oil cooler		Pressurized water forced circulation type		
	Air cleaner		Dry type		
	Cooling system		Centrifugal pump forced feeding system (pressure type)		
	Cooling fan		Inhaling type		
	Electrical system	Alternator		24 V 50 A	
Starter		24 V 4.0 kW			
Battery		12 V 80 Ah × 2 pcs. (24 V)			
Dry weight		320 kg (705 lbs.)			
Power line	Transmission	Type	Hydrostatic transmission		
		Speeds	2 speed shifts		
	Reverser		Switching the direction of flow delivered from the variable pump		
	Final drive		Planetary gear		
Vibrating system	Transmission		Hydrostatic transmission		
	Vibrator		Eccentric shaft type		
Braking device	Service brake		Hydrostatic and mechanical, multi-wet disc type		
	Parking brake		Mechanical, multi-wet disc type		
Steering system	Steering control type		Hydraulic type (Articulated type)		
	Steering control angle		± 36.7°		
	Oscillation angle		± 6.5°		
Drums	Use	Front drum		Vibrate and drive × 1	
		Rear drum		Vibrate and drive × 1	
	Dimension	Front drum	width × diameter	1,700 mm × 1,300 mm (67 in. × 51 in.)	
		Rear drum	width × diameter	1,700 mm × 1,300 mm (67 in. × 51 in.)	
	Suspension system	Front		Rubber damper type	
Rear		Rubber damper type			
Water spray system		Pressurized type			
Others	Instruments & lights		1 set		

1. ENGINE

1-1. Engine Mount

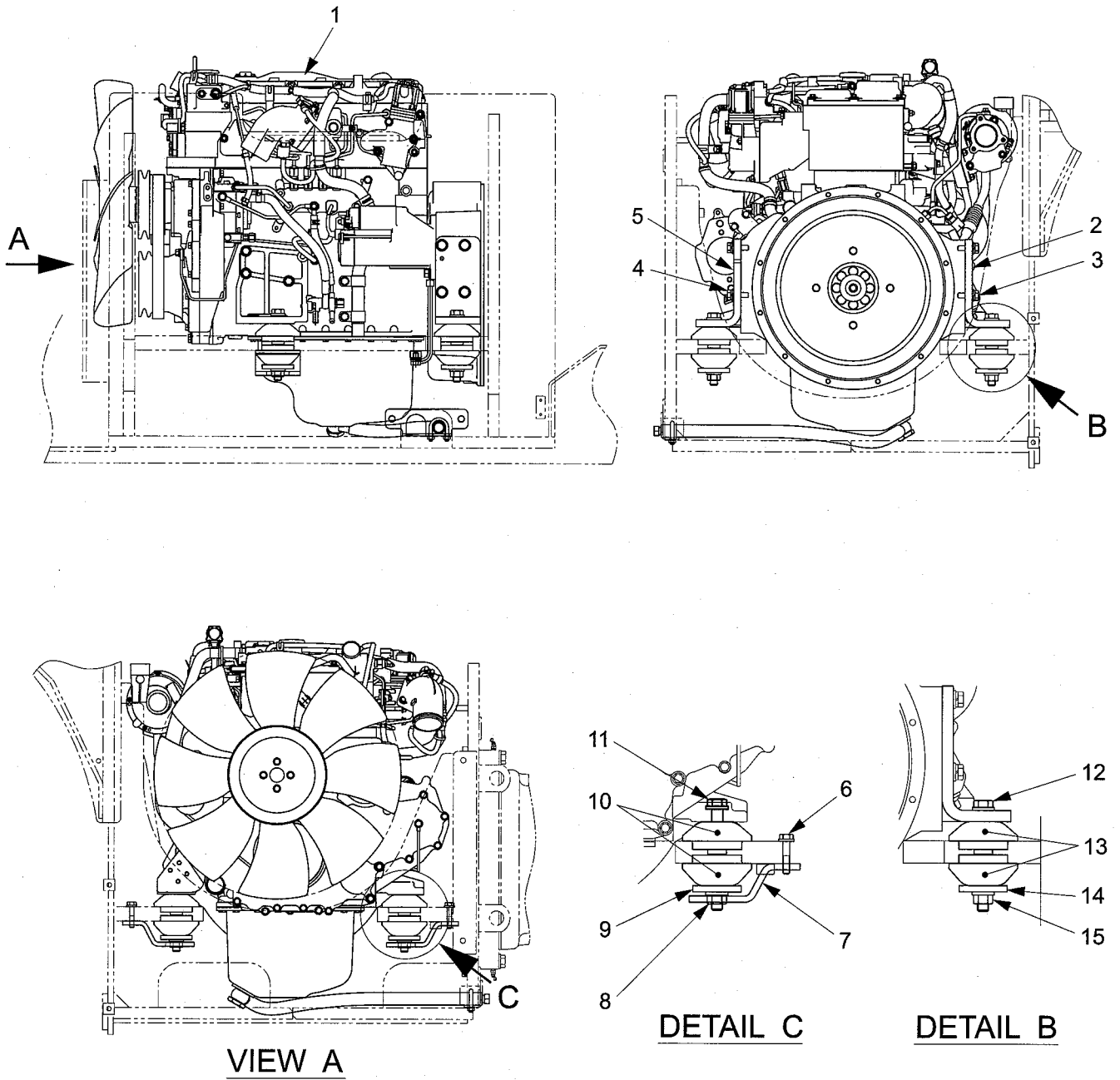

VIEW A

DETAIL C

DETAIL B

0431-01803-0-11056-0

- | | | |
|-------------------|-------------------|---------------------|
| (1) Engine | (6) Bolt : M10×50 | (11) Bolt : M16×150 |
| (2) Bracket | (7) Stopper | (12) Bolt : M16×150 |
| (3) Bolt : M12×40 | (8) Nut : M16 | (13) Damper |
| (4) Bolt : M12×40 | (9) Plate | (14) Plate |
| (5) Bracket | (10) Damper | (15) Nut : M16 |



- | | |
|---|---------------------------------------|
| (3) Bolt M12×40 : 108 N·m (80 lbf-ft) | (8) Nut M16 : 265 N·m (195 lbf-ft) |
| (4) Bolt M12×40 : 108 N·m (80 lbf-ft) | (15) Nut M16 : 265 N·m (195 lbf-ft) |
| (6) Bolt M10×50 : 59 N·m (44 lbf-ft) | |

HYDRAULIC SYSTEMS

(1) Propulsion pump

(1-1) Port B1 (Forward)	[PB1]	: 1 1/16-12UN
(1-2) Port B (Forward)	[PB]	: 1 1/16-12UN
(1-3) Drain port	[PT]	: 9/16-18UNF
(1-4) Port A (Reverse)	[PA]	: 1 1/16-12UN
(1-5) Port A1 (Reverse)	[PA1]	: 1 1/16-12UN
(1-6) Servo pressure gauge port	[PX1]	: 7/16-20UNF
(1-7) High pressure gauge port (For port B)		: 7/16-20UNF
(1-8) Servo pressure gauge port	[PX2]	: 7/16-20UNF
(1-9) Control pressure port		: 9/16-18UNF
(1-10) Drain port	[PT1]	: 1 1/16-12UN
(1-11) High pressure relief valve (For port B)		
(1-12) Charge pressure gauge port		: 3/ 4-16UNF
(1-13) High pressure relief valve (For port A)		
(1-14) High pressure gauge port		: 7/16-20UNF
(1-15) Charge relief valve		
(1-16) Drain port		: 1 1/16-12UN
(1-17) Cut off valve		
(1-18) High pressure gauge port (For port A)		: 7/16-20UNF

Specifications

• Displacement	: 56 cm ³ /rev (3.4 cu.in./rev)
• High pressure relief valve pressure setting	: 43.0 MPa (6,235 psi)
• Charge relief valve pressure setting	: 2.5 MPa (363 psi)
• Cut off valve pressure setting	: 40.0 MPa (5,800 psi)

(2) Vibrator pump

(2-1) Port B (Low amplitude/Normal)	[VPB]	: 1 1/16-12UN
(2-2) Port A (High amplitude/Horizontal)	[VPA]	: 1 1/16-12UN
(2-3) Servo pressure gauge port		: 7/16-20UNF
(2-4) Solenoid valve a (Low amplitude/Normal)		
(2-5) High pressure gauge port (For port B)		: 7/16-20UNF
(2-6) Solenoid valve b (High amplitude/Horizontal)		
(2-7) Servo pressure gauge port		: 7/16-20UNF
(2-8) Control pressure port		: 9/16-18UNF
(2-9) Drain port		: 7/ 8-14UNF
(2-10) High pressure relief valve (For port B)		
(2-11) Charge pressure gauge port	[VPG]	: 3/ 4-16UNF
(2-12) High pressure relief valve (For port A)		
(2-13) High pressure gauge port (For port A)		: 7/16-20UNF
(2-14) Drain port	[VPD]	: 7/ 8-14UNF
(2-15) Cut off valve		

Specifications

• Displacement	: 46 cm ³ /rev (2.8 cu.in./rev)
• High pressure relief valve pressure setting	: 35.0 MPa (5,075 psi)
• Cut off valve pressure setting	: 32.0 MPa (4,640 psi)
• Allowable pump case pressure	: 0.4 MPa (58.0 psi) or less
• Pump ASSY weight	: 65 kg (143 lbs.)

3-2. Hydraulic Component Specifications

3-2-1. Vibrator hydraulic motor

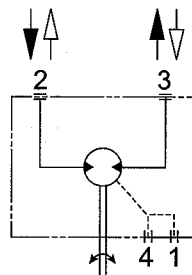
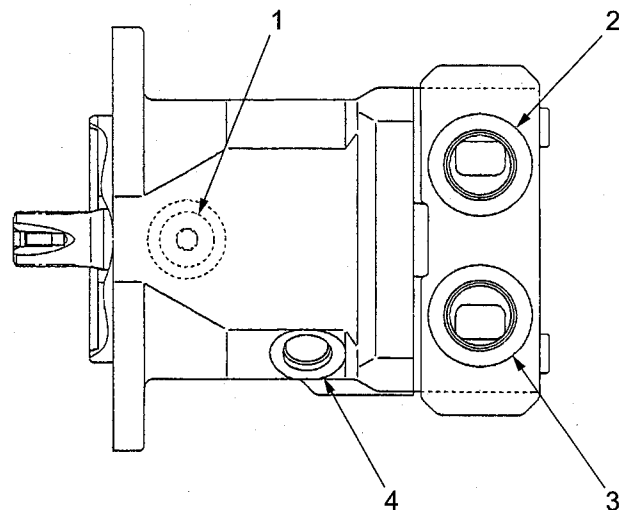
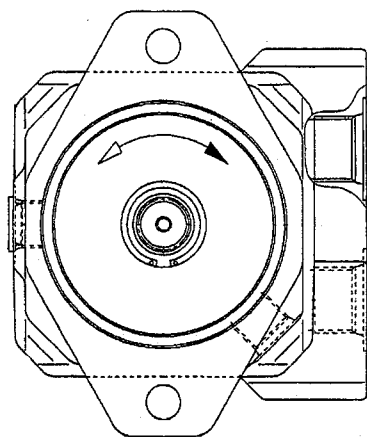

Hydraulic circuit diagram

Flow of oil

- 2→3 Clockwise rotation
- 3→2 Counterclockwise rotation

SW652-1-04005

SW770, SW770HF

- | | | | |
|----------------|---------------------------------|----------------|---------------------------------|
| (1) Drain port | : 3/ 4-16UNF | (3) Port B | [FVB, RVB] : 1 1/16-12UN |
| (2) Port A | [FVA, RVA] : 1 1/16-12UN | (4) Drain port | [FVL, RVL] : 3/ 4-16UNF |

Specifications

- Displacement : 23.5 cm³/rev (1.43 cu.in./rev)
- Working pressure : 28 MPa (4,060 psi)
- Allowable motor case pressure : 0.2 MPa (29.0 psi) or less
- Weight : 12 kg (26 lbs.)

SW770ND

- | | | | |
|----------------|---------------------------------|----------------|---------------------------------|
| (1) Drain port | : 7/ 8-14UNF | (3) Port B | [FVB, RVB] : 1 1/16-12UN |
| (2) Port A | [FVA, RVA] : 1 1/16-12UN | (4) Drain port | [FVL, RVL] : 7/ 8-14UNF |

Specifications

- Displacement : 36.7 cm³/rev (2.24 cu.in./rev)
- Working pressure : 28 MPa (4,060 psi)
- Allowable motor case pressure : 0.4 MPa (58.0 psi) or less
- Weight : 17 kg (37 lbs.)

1. PRECAUTIONS FOR WORK

1-1. Wire Numbers, Wire Sizes, Wire Colors and Connectors Shown in Electrical Circuit Diagram, Wiring Harness Layout and Wiring Harnesses

- Codes used in electrical circuit diagrams give the following information.
- The wire size is AVS 0.85 unless otherwise specified.

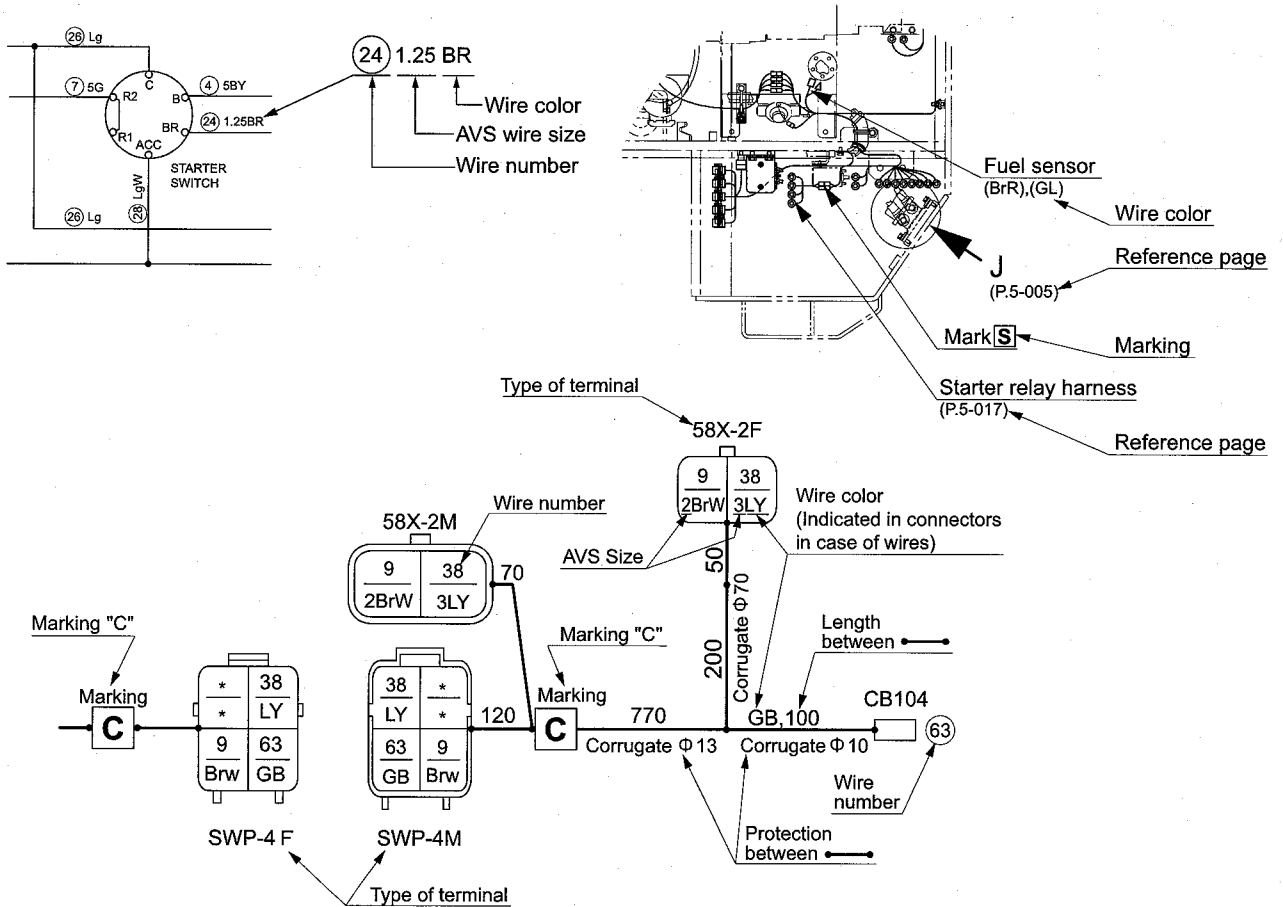

SW770-05025

- The pin or socket layout of mating connectors are symmetrical, either vertically or horizontally. When the connector halves are connected, the pin and socket that have the same number are connected.
- When connector has mark (i.e. **C**), connect with connector of certainly same mark.

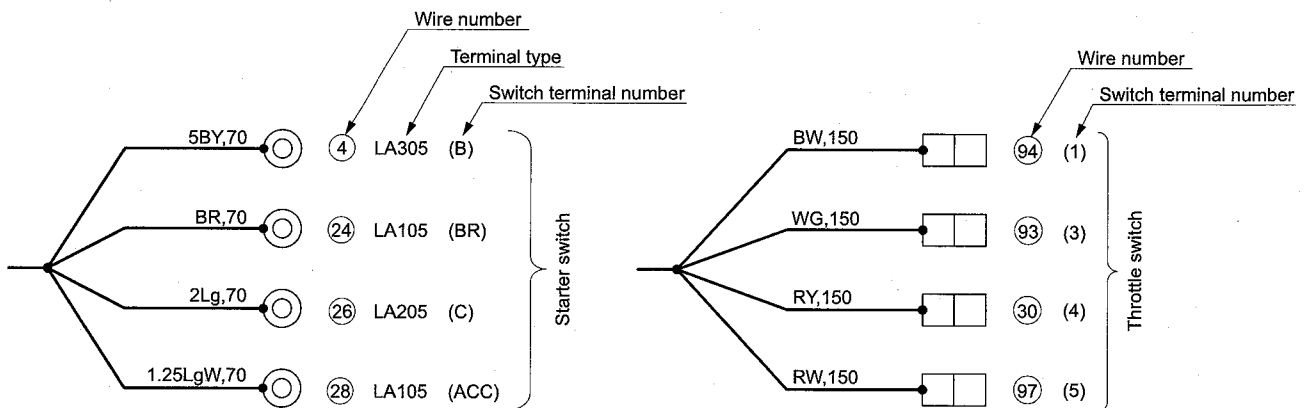

SV412-05017

3-2. Wiring Harness Layout (2)

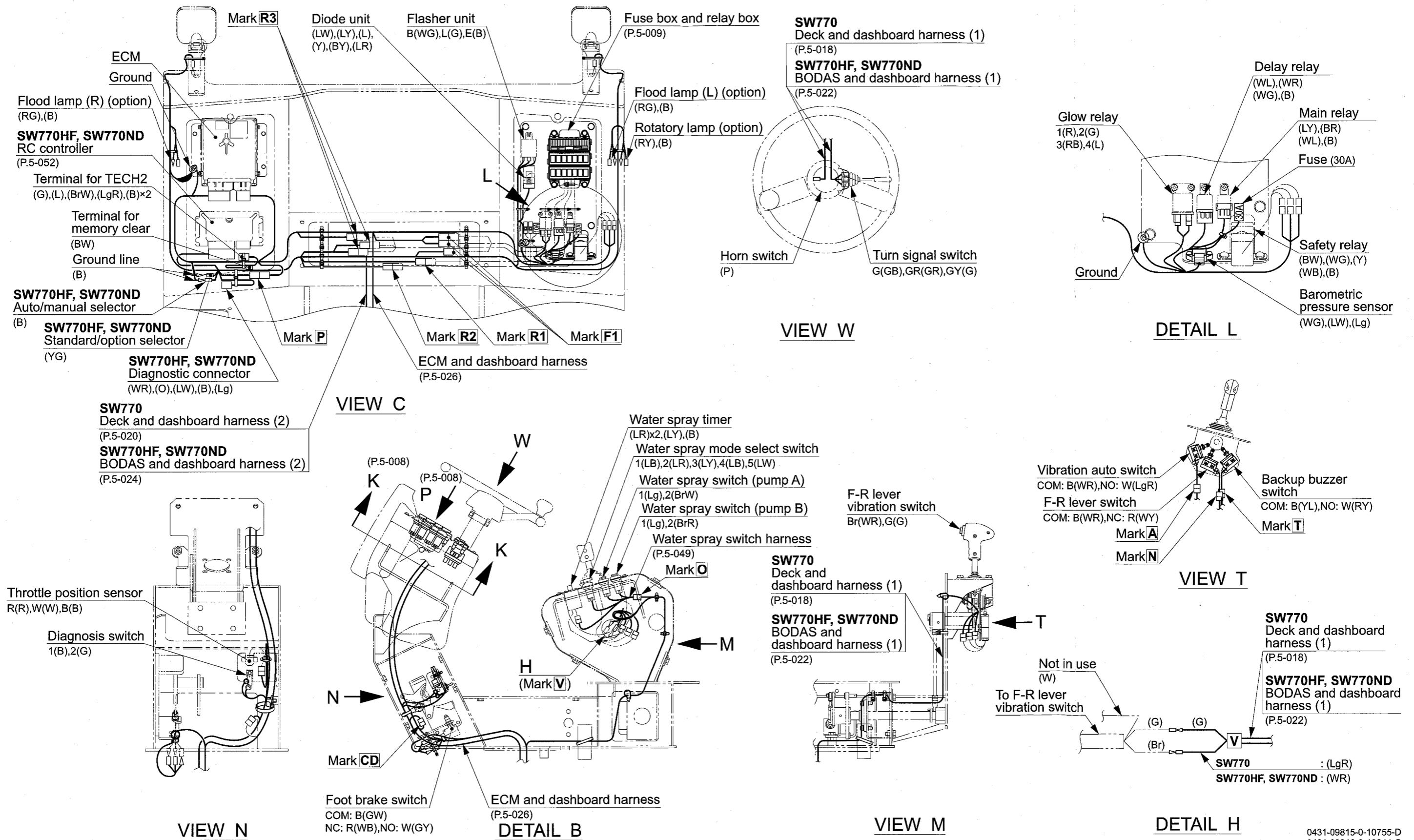

NO.	SIZE, COLOR	CONTACT POINTS	CONNECTION
②	B, 1.25B, 2B	9	B , F , SP-L × 2, SP-R × 2, VV-F , VV-R , Ground
⑭	RL	2	F , M (8M)
③②	5WR	2	B , M (2M)
③⑨	GB	2	F , M (8M)
④⑩	GR	2	F , M (8M)
④③	5R	2	B , M (2M)
④⑥	BrB	3	M (4M), SP-R × 2
④⑦	1.25RB	2	F , M (8M)

NO.	SIZE, COLOR	CONTACT POINTS	CONNECTION
④⑧	1.25RW	2	F , M (8M)
⑤③	GY	2	F , M (8M)
⑤⑦	5R	2	B , M (2F)
⑦⑤	WL	2	B , M (8M)
⑨②	5WY	2	B , M (2F)
⑨③	O	3	M (4M), SP-L × 2
⑭①	GR	2	M (4M), VV-R
⑭②	GW	2	M (4M), VV-F

NO.	SIZE, COLOR	CONTACT POINTS	CONNECTION	
			BODAS and dashboard harness (1)	BODAS and dashboard harness (2)
②	B, 1.25B, 3B	19	J , L , O , Combi. meter (16M) × 3	R1 , R2 , R3 (12F), Diagnostic connector, Flasher unit, Ground×2, RC controller-(2), (28), Exact compact meter (option), Flood lamp (option) (L), (R), Rotatory lamp (option)
⑤	BrW	2	O	R3 (12F)
⑧	LB, 2LB	3	CD , O	R3 (4F)
⑨	WR, 1.25WR	7	A , J , K , N , V	F1 , Diagnostic connector
⑪	GW	2	K	RC controller-(11)
⑫	GR	2	K	RC controller-(10)
⑬	YB	2	Combi. meter (16M)	D1 (16M)
⑭	RL	4	H , Combi. meter (12F) × 2	D1 (16M)
⑯	LgR	3	A	R3 (12F), RC controller-(45)
⑰	G	2	K , V	
⑱	L	4	K	Diode unit, RC controller-(48), Exact compact meter (option)
⑲	LW	3	K	Diode unit, RC controller-(34)
⑳	Y	3	Combi. meter (12F)	Diode unit, Exact compact meter (option)
㉑	WY	2	N	R1
㉒	LR	2	Combi. meter (16M)	D1 (16M)
㉓	YB	2	CD , Combi. meter (16M)	
㉔	RB	2	CD , Combi. meter (16M)	
㉕	YL	2	J , Combi. meter (16M)	
㉖	RG, 1.25RG	6	H , Combi. meter (12F)	Flood lamp (L), (R), Flood lamp (option) (L), (R)
㉗	YW	2	Combi. meter (16M)	D1 (16M)
㉘	GW	4	J , Foot brake switch	F1 , R1
㉙	BW	2	CD	R1
㉚	WB	2	Foot brake switch	R1
㉛	GB	4	G , Combi. meter (12F), Turn signal switch	D1 (16M)
㉜	GR	4	G , Combi. meter (12F), Turn signal switch	D1 (16M)
㉝	YL	3	T	F1 , R2
㉞	WG, 1.25WG, 2WG	5	CD , H × 2, Z	Flasher unit
㉟	1.25Lg	2	H , L	
㊱	GY	2	Foot brake switch	D1 (16M)
㊲	BrB	2		D1 (16M), R1
㊳	1.25RB	2	L	D1 (16M)
㊴	1.25RW	2	L	D1 (16M)
㊵	G	4	G × 2, Turn signal switch	Flasher unit
㊶	P	2	Horn switch	R2
㊷	RY	2	T	D1 (16M)
㊸	BY	2		F1 , R1
㊹	GY	2		D1 (16M), R2
㊺	LY, 1.25LY	3		D1 (16M), R3 (4F), Diode unit
㊻	Lg	2	O	R3 (12F)
㊼	LR, 1.25LR	3		D1 (16M), R3 (4F), Diode unit

NO.	SIZE, COLOR	CONTACT POINTS	CONNECTION	
			BODAS and dashboard harness (1)	BODAS and dashboard harness (2)
⑥②	LW	2	Combi. meter (12F)	R3 (12F)
⑥③	BY	2		D1 (8M), R3 (12F)
⑥④	BrR	3	Combi. meter (16M) × 2	R2
⑥⑤	WG	2	CD	R2
⑥⑦	BW	2	CD	F1
⑦①	BrR	2	O	R3 (12F)
⑦②	LW	2	O	R3 (12F)
⑦③	LY	2	O	R3 (12F)
⑦④	G	3	J	R1 , R3 (12F)
⑧①	BR	2	J	R1
⑧④	BY	2	Combi. meter (12F)	Diode unit
⑧⑨	GW	2	Combi. meter (12F)	D1 (8M)
⑧⑩	O	2	J	D1 (8M)
⑧⑧	WL	3	CD , Combi. meter (12F)	R2
⑩③	0.5BrW	2		P , RC controller-(40)
⑩⑤	0.5LgR	2		P , RC controller-(39)
⑩⑥	RB	3		F1 , RC controller-(41), (42)
⑩⑦	RY	3		F1 , RC controller-(1), (27)
⑩⑩	G	2		RC controller-(25), (26)
⑩⑪	GR	2		D1 (8M), RC controller-(29)
⑩⑫	GW	2		D1 (8M), RC controller-(15)
⑩⑬	LW	2		D1 (8M), RC controller-(31)
⑩⑭	L	2		D1 (8M), RC controller-(30)
⑩⑮	0.5R	2		RC controller-(33), D4 (not in use)
⑩⑯	0.5L	2		RC controller-(32), D4 (not in use)
⑩⑰	X	2		Ground, D4 (not in use)
⑩⑱	0.5R	2		RC controller-(44), D4 (not in use)
⑩⑲	0.5L	2		RC controller-(43), D4 (not in use)
⑩⑳	X	2		Ground, D4 (not in use)
⑩㉑	0.5R	2		RC controller-(37), D4 (not in use)
⑩㉒	0.5L	2		Ground, D4 (not in use)
⑩㉓	X	2		Ground, D4 (not in use)
⑩㉔	O	2		Diagnostic connector, RC controller-(51)
⑩㉕	LW	2		Diagnostic connector, RC controller-(50)
⑩㉖	B, X	3		P , Diagnostic connector, RC controller-(24)
⑩㉗	Lg	2		Diagnostic connector, RC controller-(52)
⑩㉘	LB	2	4	F1
⑩⑩①	W	2	4	RC controller-(3)
⑩⑩②	Y	2	VF	RC controller-(17)
⑩⑩③	P	2	VF	RC controller-(18)
⑩⑩④	YR	2	VF	RC controller-(7)
⑩⑩⑤	RW	2	VF	RC controller-(22)
⑩⑩⑥	B	2		Auto/manual selector, RC controller-(8)
⑩⑩⑦	RY	2	Z	Rotatory lamp (option)
⑩⑩⑧	YG	2		RC controller-(20), Standard/option selector

NO.	SIZE, COLOR	CONTACT POINTS	CONNECTION
⑧	2LB	2	1-(2), F1 (4M)
⑨	1.25WR	2	4-(2), F1 (8M)
⑮	2RB	2	7-(2), F1 (4M)
⑳	GW	2	6-(2), F1 (8M)
㉑	YL	2	3-(2), F1 (8M)
㉒	2WG	2	2-(2), F1 (4M)
㉓	BY	2	10-(1), F1 (8M)
㉔	R, 2R, 5R	5	1-(1), 2-(1), 8-(1), 9-(1), F1 (2M)

NO.	SIZE, COLOR	CONTACT POINTS	CONNECTION
⑥⑦	BW	2	10-(2), F1 (8M)
⑨②	WY, 1.25WY, 5WY	7	3-(1), 4-(1), 5-(1), 6-(1), 11-(1), 12-(1), F1 (2M)
⑨⑧	2WL	2	7-(1), F1 (4M)
⑬⑥	RB	2	9-(2), F1 (8M)
⑬⑦	RY	2	8-(2), F1 (8M)
⑮⑧	LB	2	5-(2), F1 (8M)
⑮⑩	RW	2	11-(2), F1 (1M)
⑮①	1.25GR	2	12-(2), F1 (1M)

4-19. Hazard Switch Harness

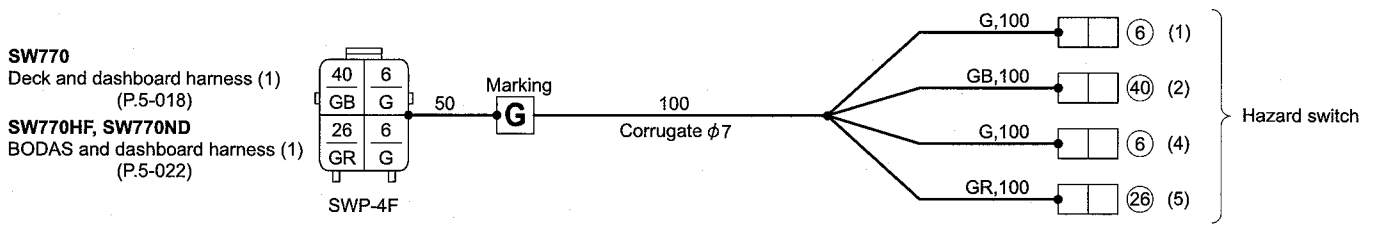

SW770-05019

NO.	SIZE, COLOR	CONTACT POINTS	CONNECTION
⑥	G	4	G × 2, Hazard switch-(1), (4)
②⑥	GR	2	G, Hazard switch-(5)
④①	GB	2	G, Hazard switch-(2)

VIBRATORY DRUM

2-1-3. Installation of vibratory drum

- 1) Install vibratory drum in reverse order in which it was removed.
 - Tightening torque for bolts where particular care is required when installing vibratory drum.



(22) Bolts M20 x 60 : 539 N·m (398 lbf-ft)

(24) Bolts M20 x 60 : 539 N·m (398 lbf-ft)

- 2) Upon installing vibratory drum, pay particular attention to items mentioned below.
 - Fill hydraulic oil tank to specified level to make up for any oil leakage.
 - Start engine and circulate oil through piping. Then check oil level again, ensuring that oil is at specified level.

(NOTICE)

- **If the engine is run at high speed or the cylinder is operated to full stroke when the engine is started for the first time after the work is completed, the piston packing or other items may be damaged by air entering into the cylinder.**

19) Remove bolts (43).

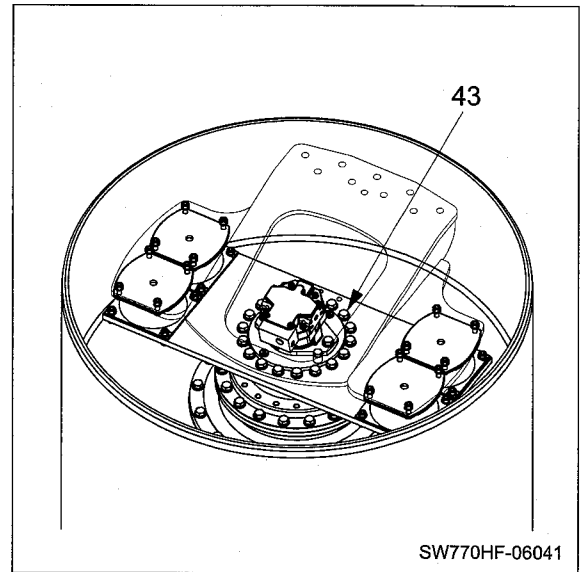

20) Remove disc SUBASSY.

Ⓜ_{kg} Disc SUBASSY : 155 kg (342 lbs.)

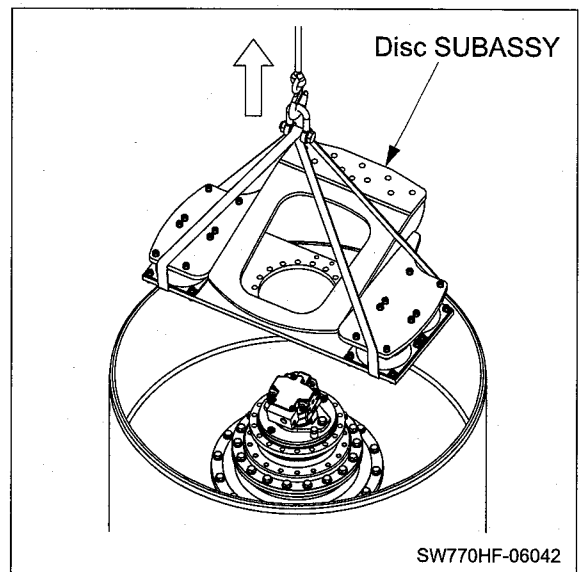

21) Install lifting bolts (M16) to propulsion motor SUBASSY.

• Remove bolts (41).

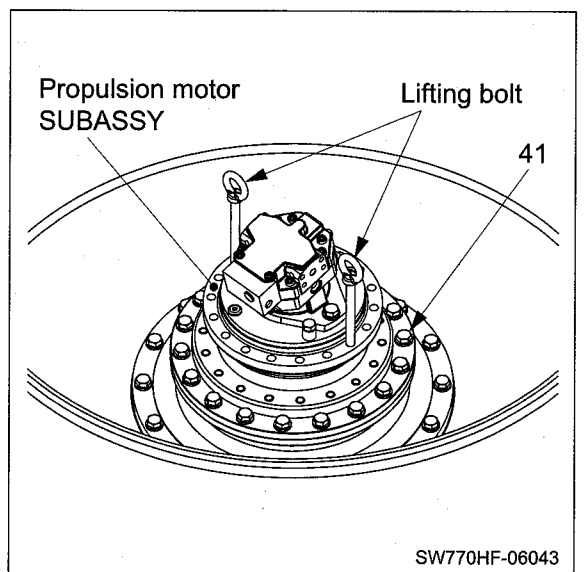

WARNING

Be careful because reversing the drum involves risk. Confirm that the surrounding area is safe, and work in a natural, unstrained posture.

14) Reverse drum SUBASSY.

 Drum SUBASSY : 2,055 kg (4,530 lbs.)

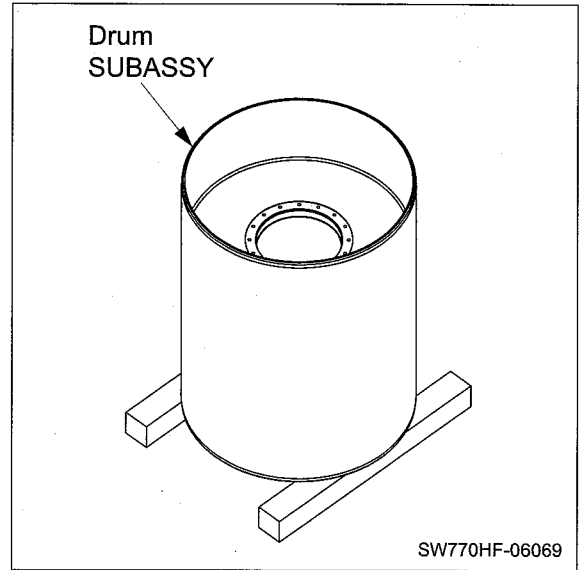

15) Install a lifting bolt (M8) to end of eccentric shaft (5).

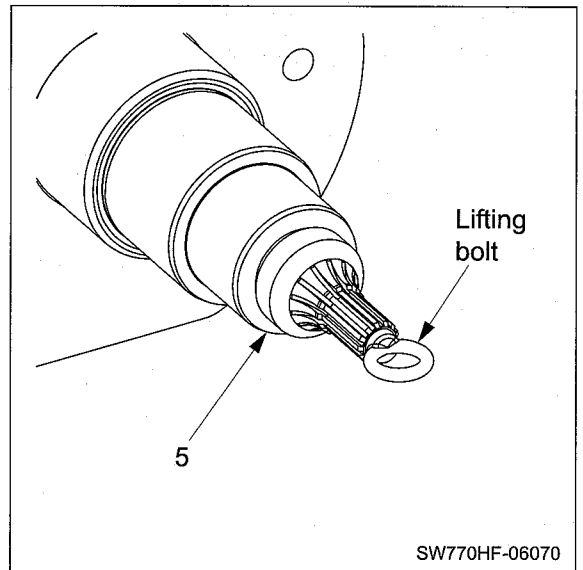

16) Apply a coat of gear oil to eccentric shaft SUBASSY at where bearing will be installed.

- Lower eccentric shaft (5).

 (5) Eccentric shaft : 80 kg (176 lbs.)

(NOTICE)

- Put the movable weight at its outmost position.

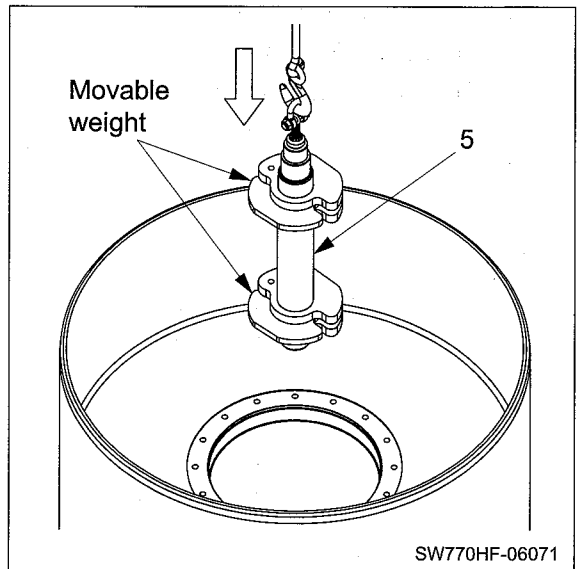

24) Slowly lift eccentric shaft with a crane and check that there is an axial play of 2 to 3 mm (0.08 to 0.12 in.).

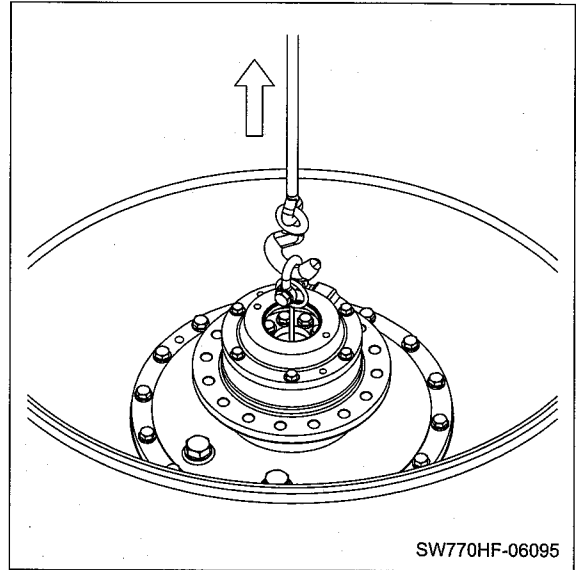

25) Wind seal tape around threaded portion of breather (10).
 • Install breather (10).

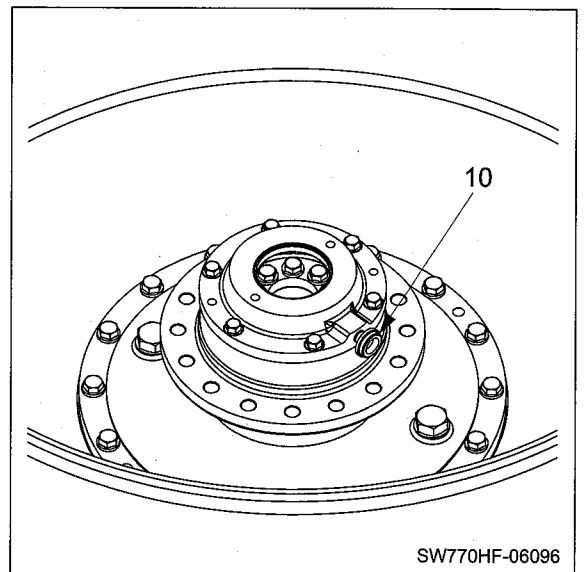

26) Put bracket (28) on axle shaft SUBASSY.

 (28) Bracket : 20 kg (44 lbs.)

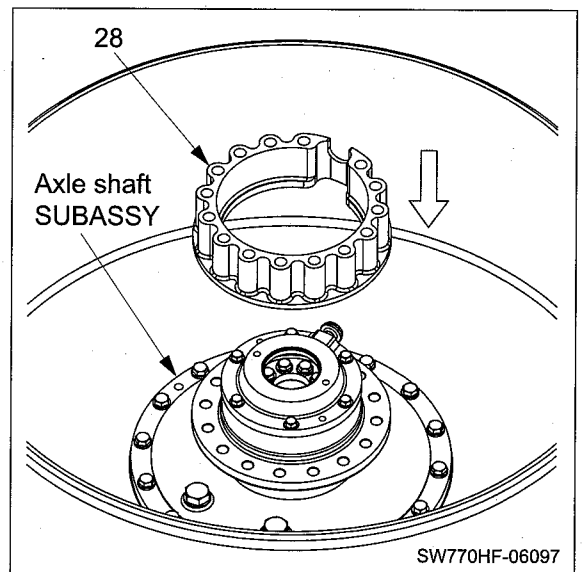

CLICK HERE TO **DOWNLOAD** THE COMPLETE MANUAL

- Thank you very much for reading the preview of the manual.
- You can download the complete manual from: www.heydownloads.com by clicking the link below



- Please note: If there is no response to CLICKING the link, please download this PDF first and then click on it.

CLICK HERE TO **DOWNLOAD** THE COMPLETE MANUAL

13) Remove axle shaft SUBASSY.

 kg Axle shaft SUBASSY : 185 kg (408 lbs.)

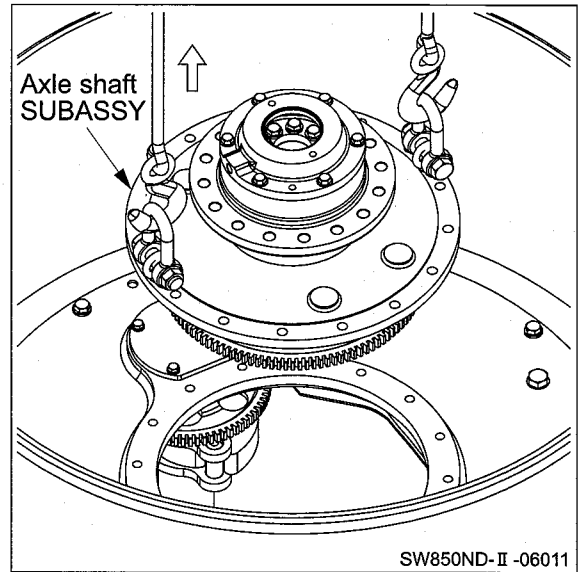

14) Put axle shaft SUBASSY on wooden blocks.
(To step (29))

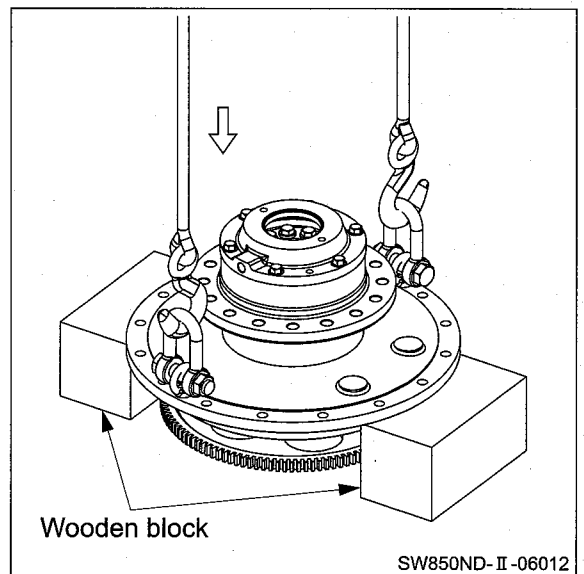

15) Remove bolts (21) and (52).
• Remove covers (22) and (51).
• Remove bolts (54).

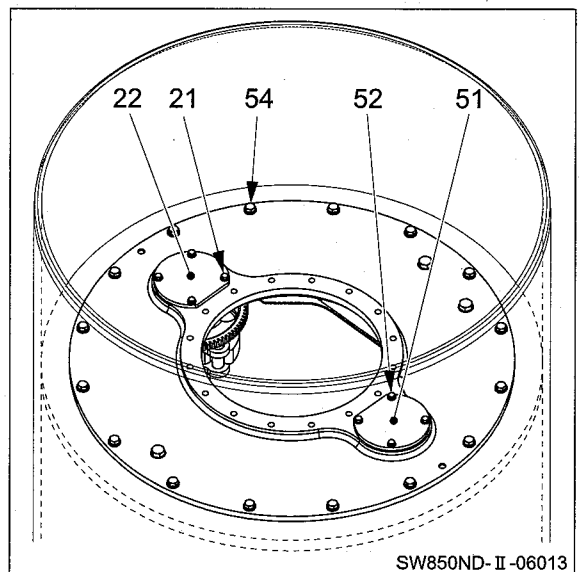

- 2-3) Apply grease to O-rings (7) and (63).
- Install O-rings (7) and (63) to covers (3) and (70).

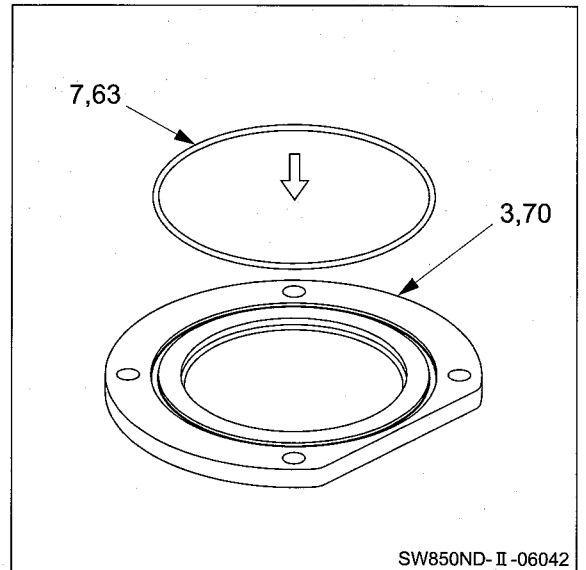

SW850ND-II-06042

- 2-4) Apply a coat liquid packing to housing SUBASSY at where covers (3) and (70) will be installed.
- Place covers (3) and (70) while making sure to orient them in the correct direction.
 - Install four bolts (4), four bolts (69) to press in bearings (6) and (64).

(NOTICE)

- Take care not to let O-ring to protrude from its groove.
- Bolts (4) and (69) are treated with thread-locking fluid. Use new thread-locking fluid treated bolts for installation.

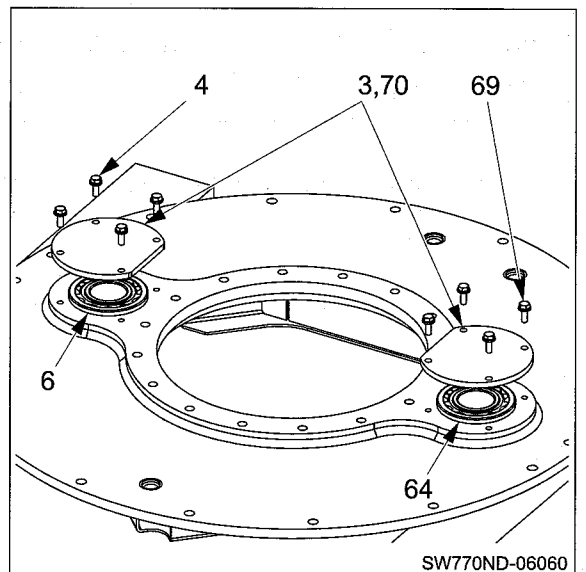

SW770ND-06060

- 2-5) Press in and secure bearings (6) and (64) with covers (3) and (70).

 (4)
 (69) Bolts M10×30 : 59 N·m (44 lbf·ft)

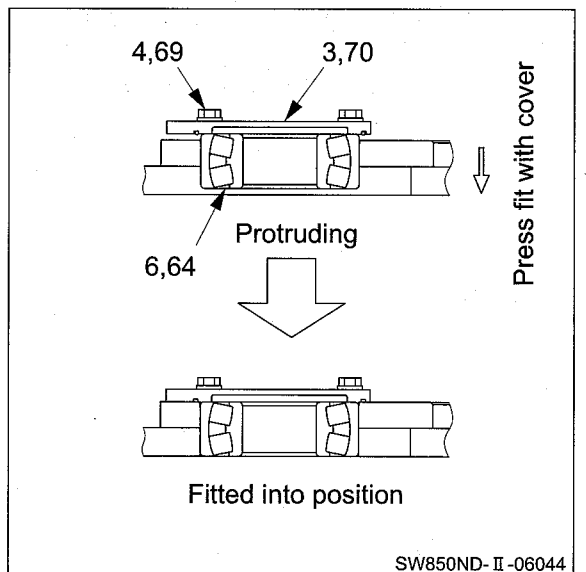

SW850ND-II-06044

23) Install lifting bolts (M16).

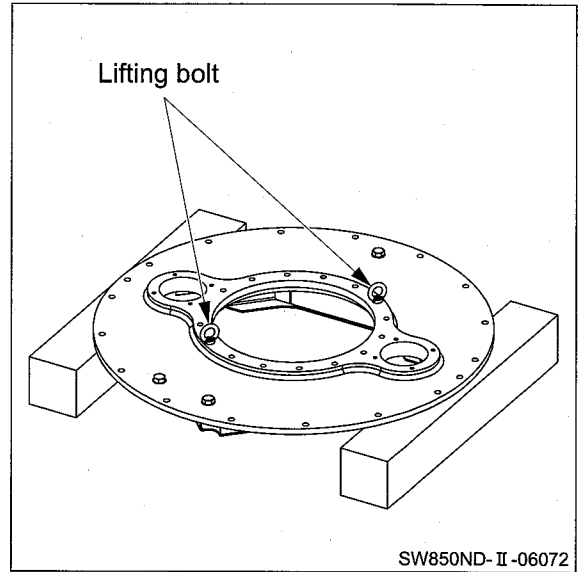

24) Lift housing (55).

\mathfrak{J}_{kg} (55) Housing : 215 kg (474 lbs.)

- Apply grease to O-ring (56).
- Install O-ring (56) to housing.

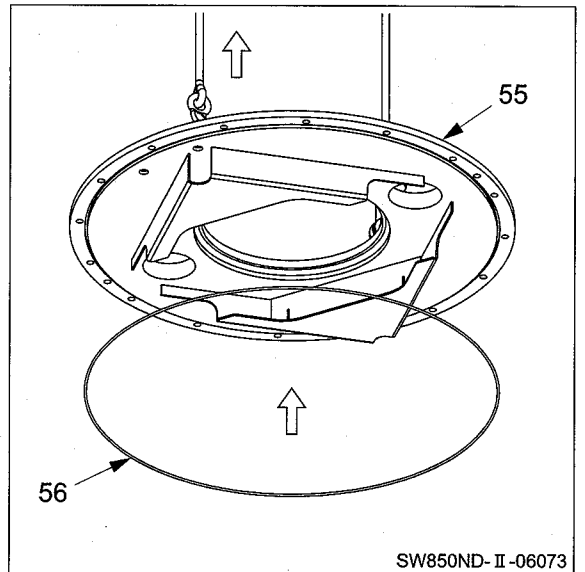

25) Lower housing (55) on mounting surface of drum.

(NOTICE)

- Take care not to let O-ring to protrude from its groove.

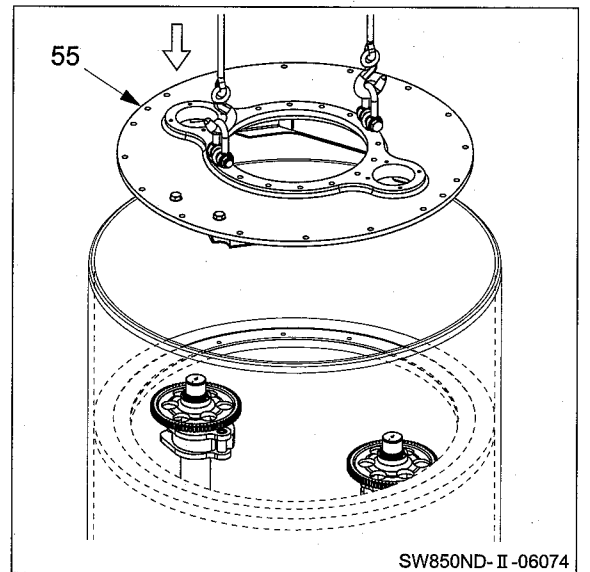

32) Secure axle shaft SUBASSY with sixteen bolts (23) and washers.



(23) Bolts M16×50 : 265 N·m (195 lbf·ft)

(NOTICE)

- Bolts (23) are treated with thread-locking fluid. Use new thread-locking fluid treated bolts for installation.

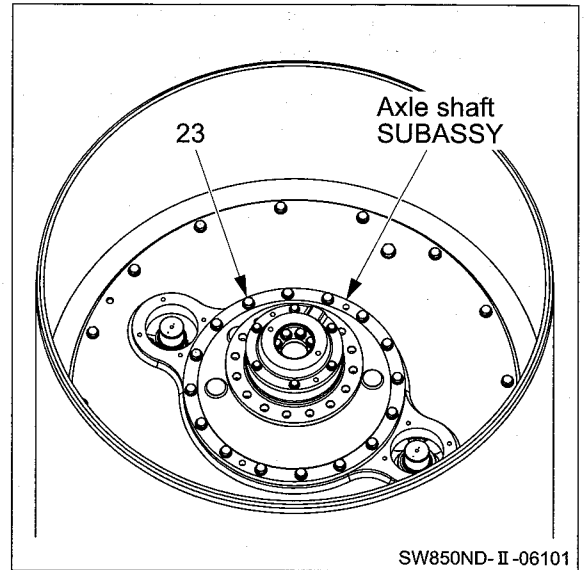

33) Make sure that punch marks on eccentric shafts A (9) and B (62) are as shown right.

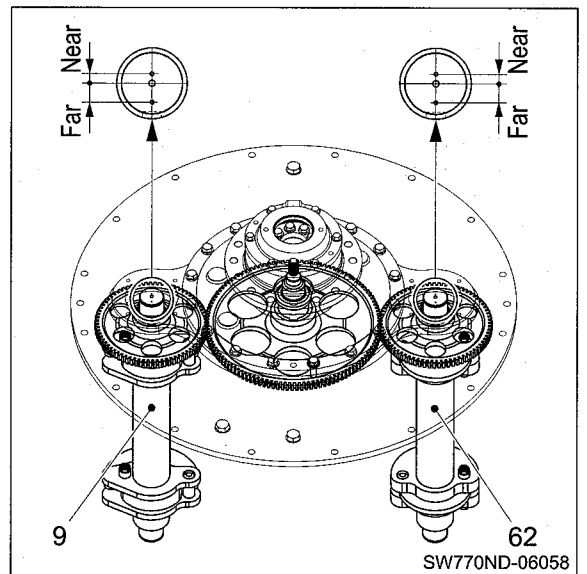

34) Apply a coat of gear oil to housing (55) at where bearings will be press-fitted and to eccentric shafts at where bearings will be installed.

- Drive in vibrator bearings (19) and (57).

(NOTICE)

- Take care not to damage the bearings (19) and (57) when installing them.

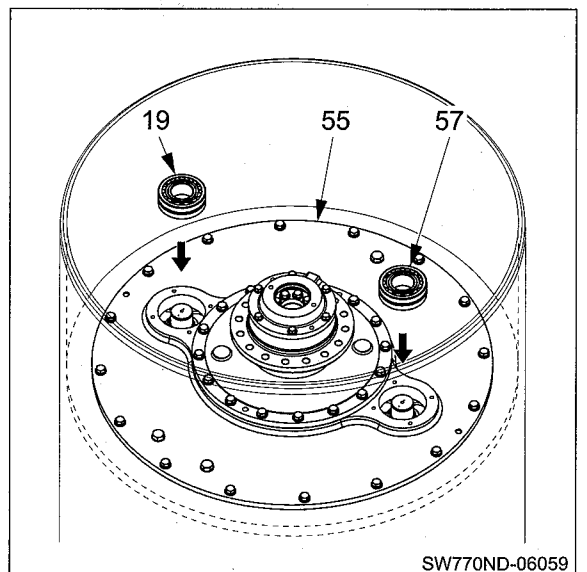

1. BRAKE PEDAL

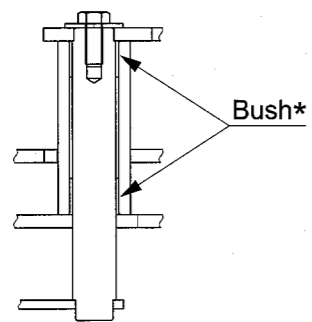
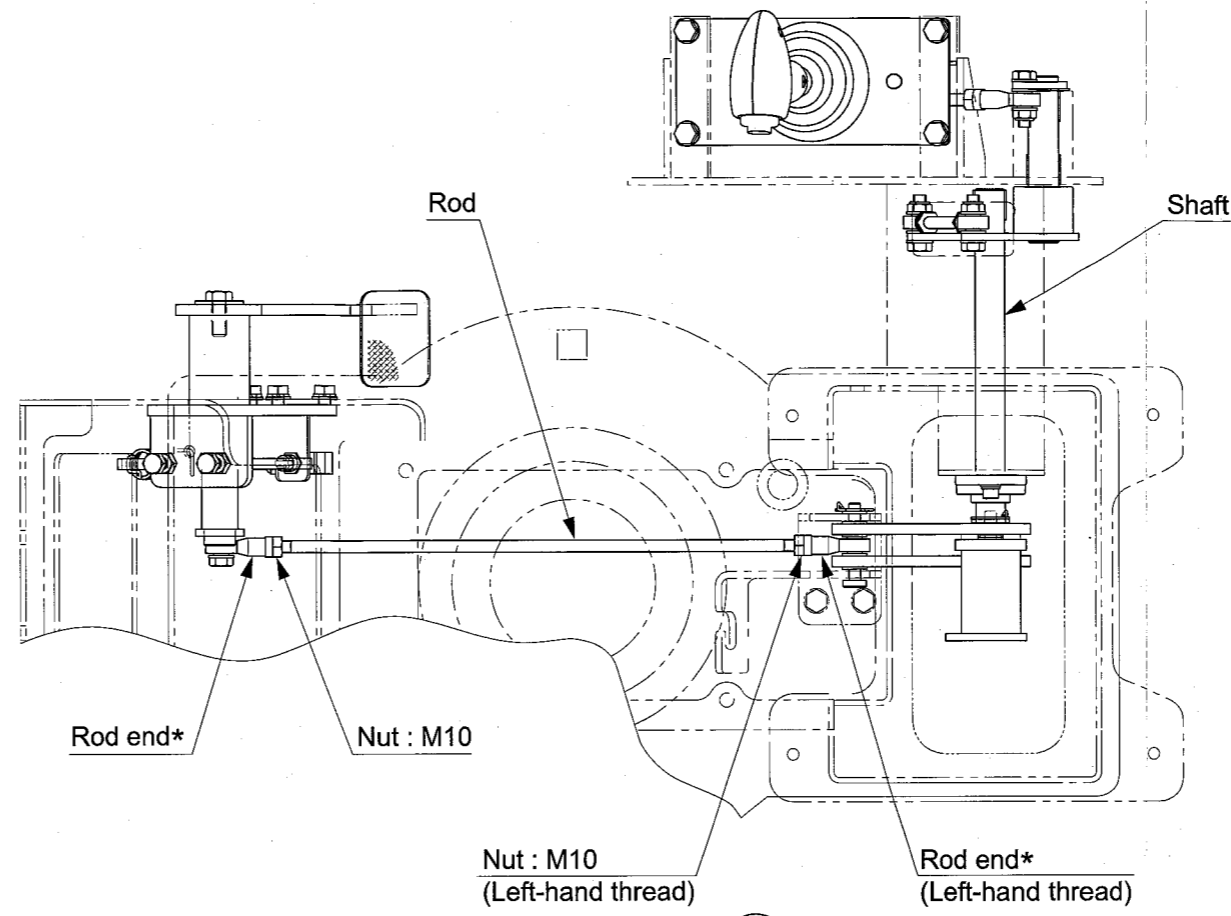

SECTION A-A

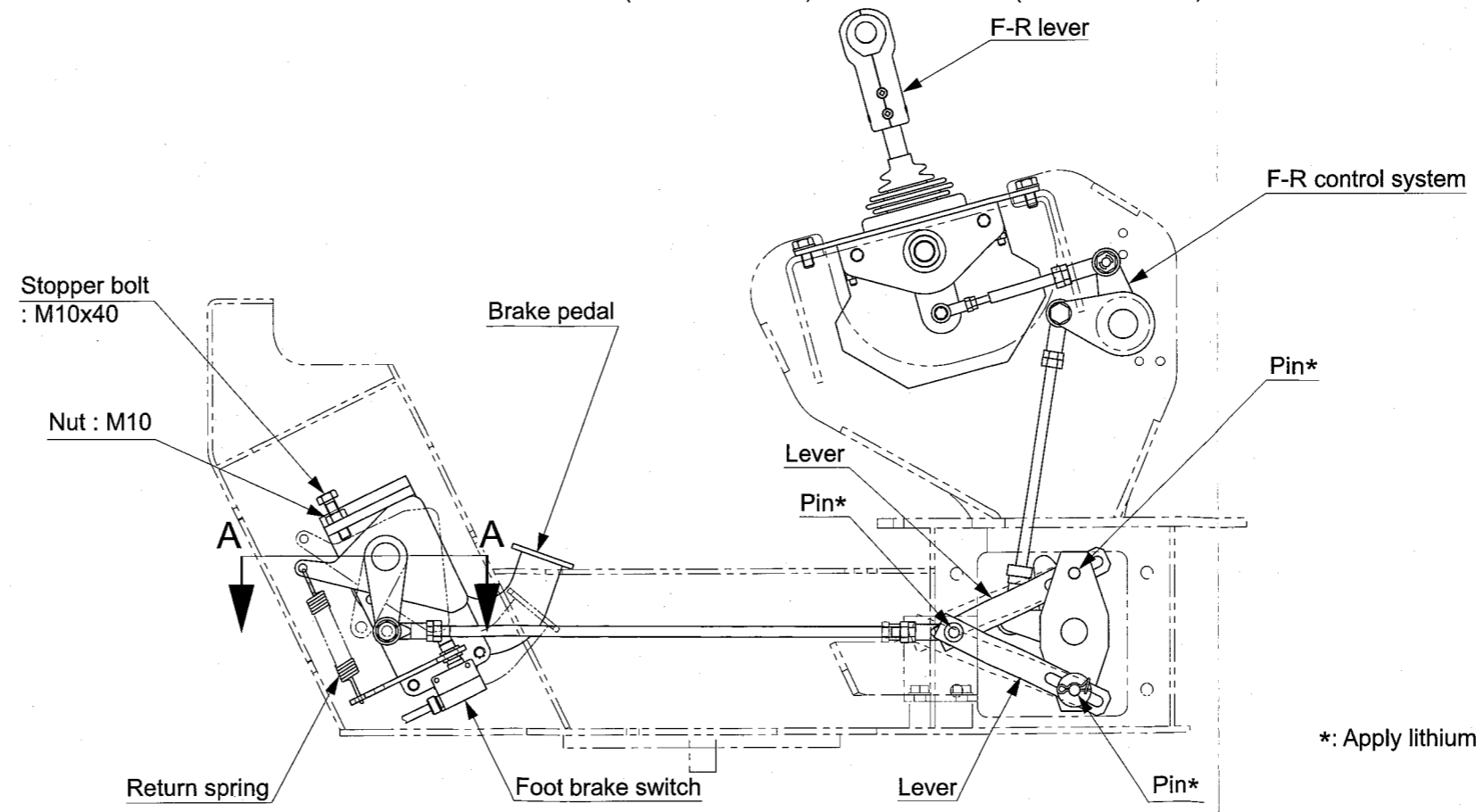

*: Apply lithium-based grease

INSPECTION AND ADJUSTMENT

4-2. Adjustment

- If measurement results indicate the pressure deviating from maximum circuit pressure range, make an adjustment in accordance with procedure described below.

- ① Check charge relief valve (1-15) for evidence of having loosened.
- ② If there is evidence of charge relief valve having loosened, adjust it so that pressure becomes within standard charge relief valve pressure setting range while watching pressure gauge.
 - To adjust pressure, remove charge relief valve and change thickness of shims (1).

Pressure change rate : 0.4 MPa/mm (58 psi/mm)

- ③ If there is no evidence of charge relief valve having loosened, remove it.
- ④ Check removed charge relief valve for trapped dirt and scratches on its seat.
- ⑤ If trapped dirt is present, disassemble and clean charge relief valve.
- ⑥ If a scratch is found on seat, replace charge relief valve.
- ⑦ After adjustment, measure pressure again and check that pressure reaches maximum circuit pressure range.



(1-15) Charge relief valve : 70 N·m (52 lbf·ft)

(NOTICE)

- **Carefully disassemble and reassemble after taking steps to prevent foreign material from getting in.**

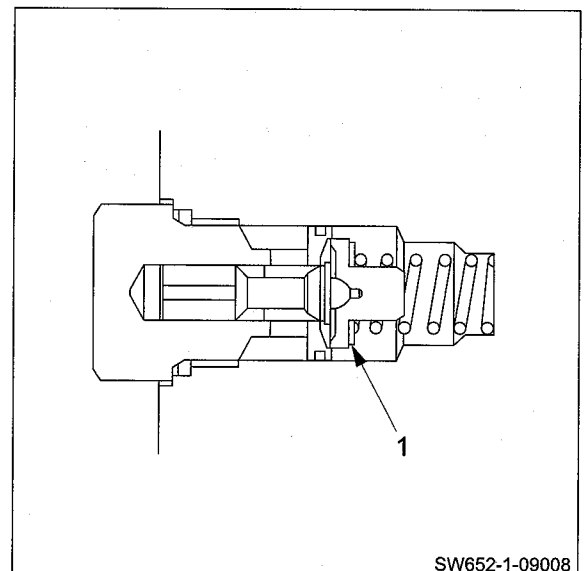
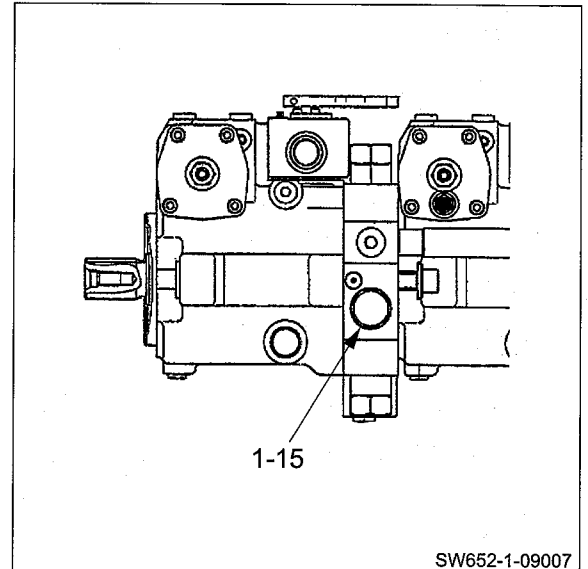

- The number "1-15" appearing in above illustrations is consistent with lead line numbers shown in illustration of propulsion pump in "2-2. Hydraulic Component Specifications" (P.4-008).

11. MEASUREMENT AND ADJUSTMENT OF VIBRATOR CIRCUIT PRESSURE (SW770HF, SW770ND)

11-1. Measurement

⚠ CAUTION

Take care not to operate the vibratory drum for a longer period of time than necessary with the machine stationary. Otherwise, the vibrator bearing could be seized.

- Oil temperature during measurement : $50 \pm 5^{\circ}\text{C}$ ($122 \pm 9^{\circ}\text{F}$)
- ① Remove plugs from high pressure gauge port (2-5) and (2-13) of vibrator pump. Attach pressure gauge with adapter ④.
 - Adapter ④ : 7/16-20UNF
 - High pressure gauge port : (2-5)
(Low amplitude/Normal)
 - High pressure gauge port : (2-13)
(High amplitude/Horizontal)
 - Pressure gauge : 0 to 50 MPa (0 to 7,250 psi)
- ② Apply parking brake by pressing parking brake switch button.
- ③ Set vibratory drum select switch to "F R".
- ④ Set vibration mode change switch to "H".
- ⑤ Start the engine and set throttle switch to "HIGH".
- ⑥ Press F-R lever vibration switch ON.
- ⑦ Slowly move F-R lever to forward or reverse side.
- ⑧ Read pressure gauge for maximum value of vibrator circuit pressure.
- ⑨ Press F-R lever vibration switch OFF or move back F-R lever to "N" as soon as measurement is finished.

★ **Maximum circuit pressure (cut off valve setting)**
: $32 \pm 1.0 \text{ MPa}$ ($4,640 \pm 145 \text{ psi}$)

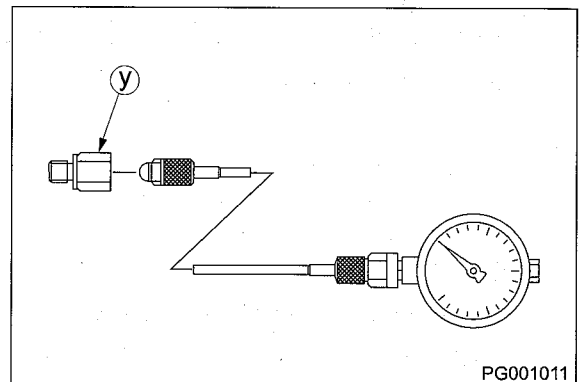
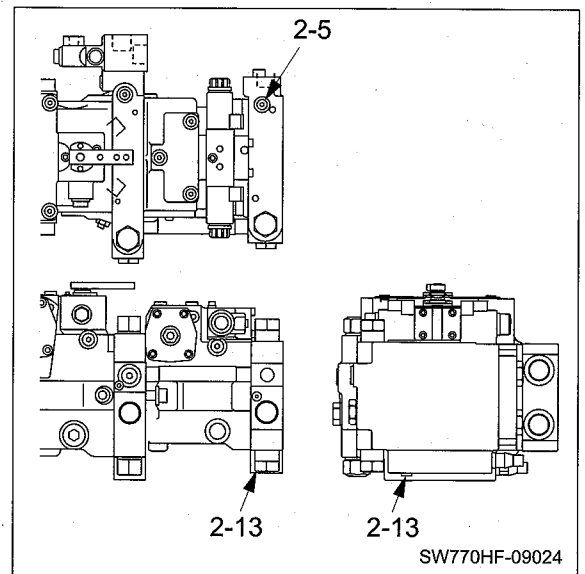

- The numbers "2-5" and "2-13" appearing in above illustrations are consistent with lead line numbers shown in illustration of vibrator pump in "2-2. Hydraulic Component Specifications" (P.4-010).

16. MEASUREMENT OF VIBRATOR MOTOR CASE PRESSURE (SW770, SW770HF)

16-1. Measurement

- Oil temperature during measurement : $50 \pm 5^{\circ}\text{C}$ ($122 \pm 9^{\circ}\text{F}$)
- ① Remove plug from drain port (1). Attach pressure gauge with adapter ①.
 - Adapter ① : 3/4-16UNF
 - Pressure gauge : 0 to 5 MPa (0 to 725 psi)
- ② Apply parking brake by pressing parking brake switch button.
- ③ Set vibratory drum select switch to "F R".
- ④ Set vibration mode change switch to "⚙".
- ⑤ Start the engine and set throttle switch to "HIGH".
- ⑥ Press F-R lever vibration switch ON.
- ⑦ Slowly move F-R lever to forward or reverse side.
- ⑧ Measure pressure when vibration select switch is "∩" and "∪" respectively.
- ⑨ Press F-R lever vibration switch OFF or move back F-R lever to "N" as soon as measurement is finished.

★ Allowable motor case pressure

: 0.2 MPa (29.0 psi) or less

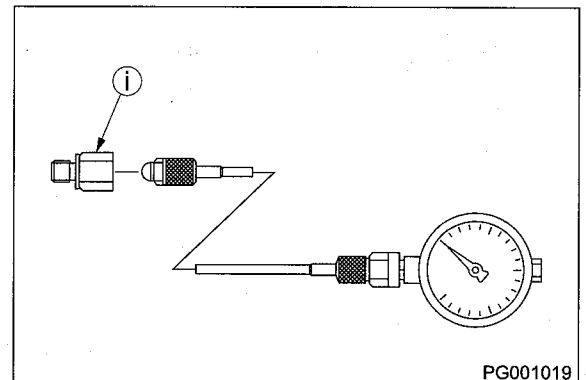
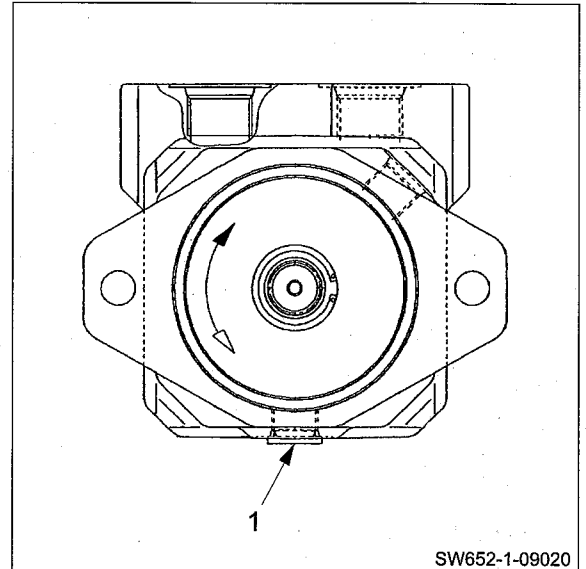

- 1-2) Measuring resistance of harness (measuring resistance between terminal 1 of equipment A and terminal 2 of equipment B)

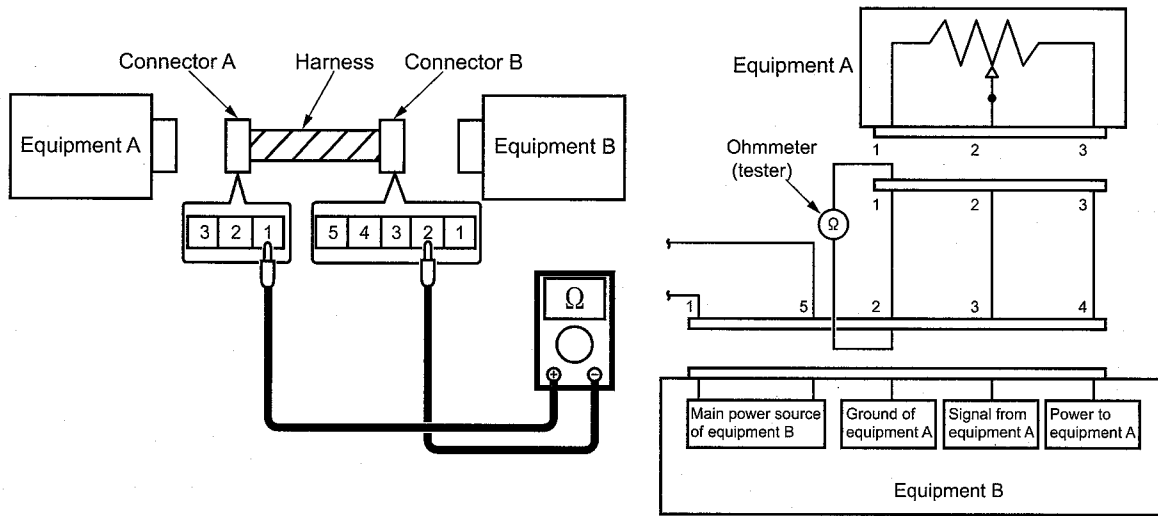

GW750-2-10005

Inspection procedure

- ① Disconnect the connectors of equipment A and equipment B.
- ② Connect the test probe (+) to connector terminal 1 of equipment A and the test probe (-) to connector terminal 2 of equipment B and measure the resistance. At this time, reversing the connector terminals between the probes (+) and (-) does not make any difference in the measurement.

Criteria for harness defects

When there is no abnormality in the harness: Less than 10 Ω (measured value)

If there is any abnormality in the harness such as broken wire: 10 Ω or higher (measured value)

- 1-3) Measuring resistance of grounding wire (measuring resistance between terminal 5 of equipment B and ground)

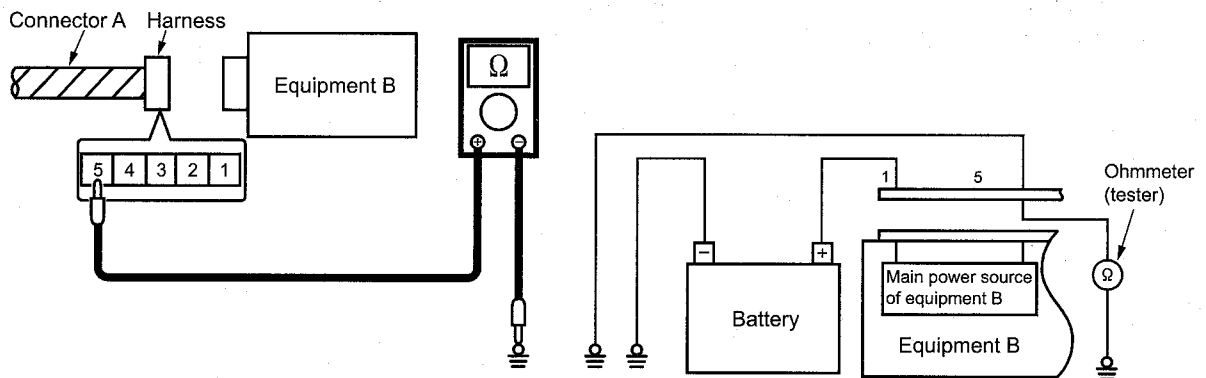

GW750-2-10006

Inspection procedure

- ① Disconnect the connector of equipment B.
- ② Connect the test probe (+) to connector terminal 5 of equipment B and the test probe (-) to a machine ground point (the bolt fastening the ground terminal or an unpainted portion on the body) and measure the resistance. At this time, reversing the connector terminals between the probes (+) and (-) does not make any difference in the measurement.

(NOTICE)

- When measuring the resistance, connect the test probes to both ends of the portion to be measured. Make also sure that no voltage is applied to the portion to be measured.
- When measuring the internal resistance of equipment, be sure first to disconnect all harnesses from the equipment.
- When measuring the resistance of a harness, disconnect the equipment connected to both ends of the harness.

TROUBLESHOOTING

Flash code (Blink of the engine check lamp)	DTC	Description	Symptom
159	P1262	Driving system of injection nozzle common 2 abnormal	Possibility of large engine vibration, rough idling, lowering output, defective blowing up, and engine stall
211	P0182	Fuel temperature sensor abnormal (Low voltage abnormality)	Nothing special
	P0183	Fuel temperature sensor abnormal (High voltage abnormality)	Nothing special
225	P1095	Pressure limiter open	Lowering output
227	P0087	No sending pressure of pump (Fuel leakage)	Possibility of large engine vibration, rough idling, lowering output, defective blowing up, generating black smoke, or excessive output
	P1093	No sending pressure of pump (Fuel leakage)	Possibility of large engine vibration, rough idling, lowering output, defective blowing up, generating black smoke, or excessive output
245	P0192	Common rail pressure sensor abnormal (Low voltage abnormality)	<ul style="list-style-type: none"> • Possibility of engine stall • Lowering output
	P0193	Common rail pressure sensor abnormal (High voltage abnormality)	<ul style="list-style-type: none"> • Possibility of engine stall • Lowering output
247	P0090	Open circuit in SVC driving system, +B short-circuited, or grounding fault	<ul style="list-style-type: none"> • Possibility of stall or blowing up depending on the open/short-circuit condition • Generating black smoke, excessive output
271	P0201	Open circuit in injection nozzle #1 driving system	Large engine vibration, rough idling, lowering output, and defective blowing up
272	P0202	Open circuit in injection nozzle #2 driving system	Large engine vibration, rough idling, lowering output, and defective blowing up
273	P0203	Open circuit in injection nozzle #3 driving system	Large engine vibration, rough idling, lowering output, and defective blowing up
274	P0204	Open circuit in injection nozzle #4 driving system	Large engine vibration, rough idling, lowering output, and defective blowing up
294	P0522	Engine oil pressure sensor abnormal (Low voltage abnormality)	Operation is not affected
	P0523	Engine oil pressure sensor abnormal (High voltage abnormality)	Operation is not affected
295	P1112	Boost temperature sensor abnormal (Low voltage abnormality)	Operation is not affected
	P1113	Boost temperature sensor abnormal (High voltage abnormality)	Operation is not affected
416	P1625	Main relay system abnormal (Will not turn on)	Engine cannot be started, and vehicle power supply cannot be turned off.
542	P1173	Overheat	Lowering output, and defective blowing up
543	P0219	Overrun	Lowering output (Injection quantity restriction is canceled when engine speed is decreased.)

(NOTICE)

- For the detail troubleshooting relating to the engine, refer to the “Troubleshooting Manual” of the engine manufacturer.

2-4-2. Engine will not start (But starter motor runs)

- In case of engine will not start while starter motor runs, generally trouble is caused by that fuel is not supplied, supply amount of fuel is extremely low, or selection of fuel is not appropriate.
- Check that fuel is supplied to inlet of fuel pump.

Reference Fig.: 2-4-1

Check point	Check/Cause	Action
1. Fuel Pump	<ul style="list-style-type: none"> • When starter switch is ON, measure voltage between fuel pump terminal inlet wire BY and chassis ground. Standard voltage : 24 V or more • If above item is OK and fuel pump does not operate, fuel pump is faulty. 	Repair or replace fuel pump.
2. Fuel Pump Relay	<ol style="list-style-type: none"> (1) When starter switch is ON, measure voltage between fuel pump relay terminal 1 inlet wire BR and chassis ground. Standard voltage : 24 V or more (2) Measure voltage between fuel pump relay terminal 3 inlet wire LW and chassis ground. Standard voltage : 24 V or more (3) When starter switch is ON, measure voltage between fuel pump relay terminal 5 outlet wire BY and chassis ground. Standard voltage : 24 V or more <ul style="list-style-type: none"> • If above items (1) and (2) are OK and item (3) is NG, fuel pump relay is faulty. 	Replace engine stop solenoid.
3. Main Relay	<ol style="list-style-type: none"> (1) When starter switch is ON, measure voltage between main relay terminal 1 inlet wire WL and chassis ground. Standard voltage : 24 V or more (2) Measure voltage between main relay terminal 5 inlet wire LY and chassis ground. Standard voltage : 24 V or more (3) When starter switch is ON, measure voltage between main relay terminal 3 outlet wire BR and chassis ground. Standard voltage : 24 V or more <ul style="list-style-type: none"> • If above items (1) and (2) are OK and item (3) is NG, main relay is faulty. 	Replace main relay.
4. ECM	<ol style="list-style-type: none"> (1) When starter switch is ON, measure voltage between ECM terminal V24 wire RB and chassis ground. Standard voltage : 24 V or more (2) Check ECM terminals are reliably grounded. <ul style="list-style-type: none"> • ECM terminals V1, V3, V4, V43 and V62 wires B • ECM terminal V81 wire B (3) When starter switch is ON, measure voltage between ECM terminals V21, V40 wires WL and chassis ground. Standard voltage : 24 V or more <ul style="list-style-type: none"> • If above items (1) and (2) are OK and item (3) is NG, ECM is faulty. 	Replace ECM.
5. Harness Connecting Between Terminals	<ul style="list-style-type: none"> • Measure resistance of harness connecting between terminals. Standard resistance : 10 Ω or less • If resistance is abnormal, harness is faulty. 	Repair or replace harness.

2-5-1. Machine moves neither forward nor backward 3/3

- Parking brake switch must be released.
- Foot brake switch must be ON (Brake pedal is not depressed).

Reference Fig.: 2-5-1

Check point	Check/Cause	Action
8. Holding Relay	(1) When starter switch is ON, measure voltage between holding relay terminal 3 inlet wire GW and chassis ground. Standard voltage : 24 V or more (2) When starter switch is ON and F-R lever is "N", measure voltage between holding relay terminal 1 inlet wire BrB and chassis ground. Standard voltage : 24 V or more (3) After starting engine and F-R lever is "F" or "R", measure voltage between holding relay terminal 1 inlet wire BrB and chassis ground. Standard voltage : 24 V or more (4) When starter switch is ON and F-R lever is "N", or after starting engine and F-R lever is "F" or "R", measure voltage between holding relay terminal 5 outlet wire GR and chassis ground. Standard voltage : 24 V or more • If above items (1), (2) and (3) are OK and item (4) is NG, holding relay is faulty.	Replace holding relay.
9. Harness Connecting Between Terminals	• Measure resistance of harness connecting between terminals. Standard resistance : 10 Ω or less • If resistance is abnormal, harness is faulty.	Repair or replace harness.

2-5-2. Machine speed cannot be changed

- Speed change switch must be "  ".

Reference Fig.: 2-5-1

Check point	Check/Cause	Action
1. Speed Change Solenoid	• Disconnect harness and measure resistance of coil. Standard resistance : 30.5 Ω • If measured resistance is abnormal, speed change solenoid is faulty.	Replace speed change solenoid.
2. Speed Change Switch	(1) When starter switch is ON, measure voltage between speed change switch terminal 1 inlet wire WR and chassis ground. Standard voltage : 24 V or more (2) When starter switch is ON, measure voltage between speed change switch terminal 2 outlet wire O and chassis ground. Standard voltage : 24 V or more • If above item (1) is OK and (2) is NG, speed change switch is faulty.	Replace speed change switch.
3. Harness Connecting Between Terminals	• Measure resistance of harness connecting between terminals. Standard resistance : 10 Ω or less • If resistance is abnormal, harness is faulty.	Repair or replace harness.

2-6-1. No vibration occurs 4/4

- Vibration mode change switch must be "AUTO" (automatic mode).
- Vibration select switch must not be "○".

Reference Fig.: 2-6-1

Check point	Check/Cause	Action
8. RC Controller (SW770HF, SW770ND)	<p>(1) When starter switch is ON, measure voltage between RC controller terminals and chassis ground.</p> <ul style="list-style-type: none"> • Terminal 1, 27 inlet wires RY and chassis ground. • Terminal 41, 42 inlet wires RB and chassis ground. • Terminal 45 inlet wire LgR and chassis ground. • Terminal 34 inlet wire LW and chassis ground when vibration select switch is "∩" / "⊙". • Terminal 48 inlet wire L and chassis ground when vibration select switch is "∩" / "⊙". <p>Standard voltage : 24 V or more</p> <p>(2) Check RC controller terminals are reliably grounded.</p> <ul style="list-style-type: none"> • Terminal 2 and 28 wires B. <p>(3) After starting engine, check current flows between RC controller terminals and vibrator pump solenoids.</p> <ul style="list-style-type: none"> • Terminal 30 outlet wire L and vibrator solenoid D (L) when vibration select switch is "∩" / "⊙". • Terminal 31 outlet wire LW and vibrator solenoid C (H) when vibration select switch is "∩" / "⊙". <p>There is current flow.</p> <ul style="list-style-type: none"> • If above items (1) and (2) are OK and item (3) is NG, RC controller is faulty. 	Replace RC controller.
9. Harness Connecting Between Terminals	<ul style="list-style-type: none"> • Measure resistance of harness connecting between terminals. Standard resistance : 10 Ω or less • If resistance is abnormal, harness is faulty. 	Repair or replace harness.

2-6-3. Frequency does not change (Remains either frequency) (SW770HF) 2/2

- Vibration mode change switch must be "AUTO" (automatic mode).
- Vibration select switch must be "√^".

Reference Fig. : 2-6-1

Check point	Check/Cause	Action
6. RC controller	<p>(1) When starter switch is ON, measure voltage between RC controller terminals and chassis ground.</p> <ul style="list-style-type: none"> • Terminal 1, 27 inlet wires RY and chassis ground. • Terminal 41, 42 inlet wires RB and chassis ground. • Terminal 45 inlet wire LgR and chassis ground. • Terminal 34 inlet wire LW and chassis ground when vibration select switch is "√^". • Terminal 48 inlet wire L and chassis ground when vibration select switch is "√^". <p>Standard voltage : 24 V or more</p> <p>(2) Check RC controller terminals are reliably grounded.</p> <ul style="list-style-type: none"> • Terminal 2 and 28 wires B. <p>(3) After starting engine and vibration frequency select switch is 2500, 3000 or 4000, measure current between RC controller terminals and vibrator pump solenoids respectively.</p> <ul style="list-style-type: none"> • Terminal 30 outlet wire L for low amplitude, 2500, 3000 and 4000 rpm. • Terminal 31 outlet wire LW for high amplitude, 2500 and 3000 rpm. <p>Standard current : In between 200 mA to 600 mA</p> <ul style="list-style-type: none"> • If above items (1), (2) and (3) are OK, but when no change frequency, RC controller is faulty. 	Replace RC controller.
7. Harness Connecting Between Terminals	<ul style="list-style-type: none"> • Measure resistance of harness connecting between terminals. <p>Standard resistance : 10 Ω or less</p> <ul style="list-style-type: none"> • If resistance is abnormal, harness is faulty. 	Repair or replace harness.

2-7-2. Continuous water spray works, but auto water spray does not operate

- Water spray mode select switch must be "AUTO".
- F-R lever must be "F" or "R".

Reference Fig.: 2-7-1

Check point	Check/Cause	Action
1. Water Spray Mode Select Relay	<p>(1) When starter switch is ON, measure voltage between water spray mode select relay terminal 1 inlet wire LW and chassis ground. Standard voltage : 24 V or more</p> <p>(2) When starter switch is ON, measure voltage between water spray mode select relay terminal 5 inlet wire LgR and chassis ground. Standard voltage : 24 V or more</p> <p>(3) When starter switch is ON, measure voltage between water spray mode select relay terminal 3 outlet wire Lg and chassis ground. Standard voltage : 24 V or more</p> <ul style="list-style-type: none"> • If above items (1) and (2) are OK and item (3) is NG, water spray mode select relay is faulty. 	Replace water spray mode select relay.
2. Vibration Auto Switch	<p>(1) When starter switch is ON, measure voltage between vibration auto switch terminal COM inlet wire WR and chassis ground. Standard voltage : 24 V or more</p> <p>(2) When starter switch is ON, measure voltage between vibration auto switch terminal NO outlet wire LgR and chassis ground. Standard voltage : 24 V or more</p> <ul style="list-style-type: none"> • If above item (1) is OK and item (2) is NG, vibration auto switch is faulty. 	Replace vibration auto switch.
3. Water Spray Mode Select Switch	<p>(1) When starter switch is ON, measure voltage between water spray mode select switch terminal 4 inlet wire LB and chassis ground. Standard voltage : 24 V or more</p> <p>(2) When starter switch is ON, measure voltage between water spray mode select switch terminal 5 outlet wire LW and chassis ground. Standard voltage : 24 V or more</p> <ul style="list-style-type: none"> • If above item (1) is OK and item (2) is NG, water spray mode select switch is faulty. 	Replace water spray mode select switch.
4. Harness Connecting Between Terminals	<ul style="list-style-type: none"> • Measure resistance of harness connecting between terminals. Standard resistance : 10 Ω or less • If resistance is abnormal, harness is faulty. 	Repair or replace harness.

2-8-5. Hazard lamp does not light (Turn signal blinks)

Reference Fig.: 2-8-1

Check point	Check/Cause	Action
1. Each Bulb	<ul style="list-style-type: none"> • Check none of lamp bulbs is burned out or has a contact failure. • Bulb is faulty or poorly connected. 	Replace each bulb.
2. Hazard Switch	<p>(1) When starter switch is ON, measure voltage between hazard switch terminal 1 and 4 inlet wire G and chassis ground. Standard voltage : 24 V or more with constant intervals</p> <p>(2) When starter switch is ON and hazard switch is ON, measure voltage between hazard switch terminal 2 outlet wire GB and chassis ground. Standard voltage : 24 V or more with constant intervals</p> <p>(3) When starter switch is ON and hazard switch is ON, measure voltage between hazard switch terminal 5 outlet wire GR and chassis ground. Standard voltage : 24 V or more with constant intervals</p> <ul style="list-style-type: none"> • If above item (1) is OK and item (2) or (3) is NG, hazard switch is faulty. 	Replace hazard switch.
3. Harness Connecting Between Terminals	<ul style="list-style-type: none"> • Measure resistance of harness connecting between terminals. Standard resistance : 10 Ω or less • If resistance is abnormal, harness is faulty. 	Repair or replace harness.

2-8-6. Backup lamp does not light

Reference Fig.: 2-8-1

Check point	Check/Cause	Action
1. Each Bulb	<ul style="list-style-type: none"> • Check that none of lamp bulbs is burned out or has a contact failure. • Bulb is faulty or poorly connected. 	Replace each bulb.
2. Backup Buzzer Switch	<p>(1) When starter switch is ON, measure voltage between backup buzzer switch terminal COM inlet wire YL and chassis ground. Standard voltage : 24 V or more</p> <p>(2) When starter switch is ON and F-R lever is "R", measure voltage between backup buzzer switch terminal NO outlet wire RY and chassis ground. Standard voltage : 24 V or more</p> <ul style="list-style-type: none"> • If above item (1) is OK and item (2) is NG, backup buzzer switch is faulty. 	Replace backup buzzer switch.
3. Harness Connecting Between Terminals	<ul style="list-style-type: none"> • Measure resistance of harness connecting between terminals. Standard resistance : 10 Ω or less • If resistance is abnormal, harness is faulty. 	Repair or replace harness.

2-8-12. Temperature meter is abnormal

Reference Fig. : 2-8-2

Check point	Check/Cause	Action
1. Thermo Unit	<ul style="list-style-type: none"> • Disconnect harness and measure resistance of thermo unit. Standard resistance : 164.6 Ω [(at unit temperature of 50°C (122°F))] 26.44 Ω [(at unit temperature of 103°C (217°F))] • If resistance is abnormal, thermo unit is faulty. 	Replace thermo unit.
2. Combination Meter (Coolant temperature meter)	<ul style="list-style-type: none"> • When starter switch is ON, measure voltage between combination meter terminal wires and ground terminal wire. • Battery terminal wire No. 62 inlet wire LW and ground terminal wire No. 2 wire B. • Starter switch terminal wire No. 98 inlet wire WL and ground terminal wire No. 2 wire B. Standard voltage : 24 V or more • If no abnormality is found, combination meter is faulty. 	Replace combination meter.
3. Harness Connecting Between Terminals	<ul style="list-style-type: none"> • Measure resistance of harness connecting between terminals. Standard resistance : 10 Ω or less • If resistance is abnormal, harness is faulty. 	Repair or replace harness.

2-8-13. Fuel meter is abnormal

Reference Fig. : 2-8-2

Check point	Check/Cause	Action
1. Fuel Unit	<ul style="list-style-type: none"> • Disconnect harness and measure resistance of fuel unit. Standard resistance : 13.5 Ω (with float in "F") 80.0 Ω (with float in "E") • If resistance is abnormal, fuel unit is faulty. 	Replace fuel unit.
2. Combination Meter (Fuel meter)	<ul style="list-style-type: none"> • When starter switch is ON, measure voltage between combination meter terminal wires and ground terminal wire. • Battery terminal wire No. 62 inlet wire LW and ground terminal wire No. 2 wire B. • Starter switch terminal wire No. 98 inlet wire WL and ground terminal wire No. 2 wire B. Standard voltage : 24 V or more • If no abnormality is found, combination meter is faulty. 	Replace combination meter.
3. Harness Connecting Between Terminals	<ul style="list-style-type: none"> • Measure resistance of harness connecting between terminals. Standard resistance : 10 Ω or less • If resistance is abnormal, harness is faulty. 	Repair or replace harness.

2-8-19. Water spray indicator lamp does not light

- Check that water spray pump can be activated.
- Water spray mode select switch must be "CONT".

Reference Fig. : 2-8-7

Check point	Check/Cause	Action
1. Harness	<p>(1) Measure resistance between water spray relay (pump A) terminal 5 wire LY and diode unit terminal D wire LY. Standard resistance : 10 Ω or less</p> <p>(2) Measure resistance between water spray relay (pump B) terminal 5 wire LR and diode unit terminal I wire LR. Standard resistance : 10 Ω or less</p> <p>(3) Measure resistance between diode unit terminal H wire BY and combination meter connector terminal wire No. 84 wire BY. Standard resistance : 10 Ω or less</p> <ul style="list-style-type: none"> • If above items (1) , (2) or (3) is NG, harness is faulty. 	Repair or replace harness.
2. Diode Unit	<p>(1) When starter switch is ON, water spray switch (pump A) is ON, measure voltage between diode unit terminal D inlet wire LY and chassis ground. Standard voltage : 24 V or more</p> <p>(2) When starter switch is ON, water spray switch (pump B) is ON, measure voltage between diode unit terminal I inlet wire LR and chassis ground. Standard voltage : 24 V or more</p> <p>(3) When starter switch is ON, water spray switch (pump A) or (pump B) is ON, measure voltage between diode unit terminal H outlet wire BY and chassis ground. Standard voltage : 24 V or more</p> <ul style="list-style-type: none"> • If above items (1) and (2) are OK and item (3) is NG, diode unit is faulty. 	Replace diode unit.
3. Combination Meter (Water spray indicator lamp)	<p>(1) When starter switch is ON, measure voltage between combination meter terminal wires and ground terminal wire.</p> <ul style="list-style-type: none"> • Battery terminal wire No. 62 inlet wire LW and ground terminal wire No. 2 wire B. • Starter switch terminal wire No. 98 inlet wire WL and ground terminal wire No. 2 wire B. <p>Standard voltage : 24 V or more</p> <p>(2) When starter switch is ON, water spray switch (pump A) or (pump B) is ON, measure voltage between combination meter water spray terminal wire No. 84 inlet wire BY and chassis ground. Standard voltage : 24 V or more</p> <ul style="list-style-type: none"> • If above items (1) and (2) are OK and water spray indicator lamp does not light, combination meter is faulty. 	Replace combination meter.

3-2. Propulsion System

If a problem occurs in the propulsion systems such as the propulsion pump, propulsion motor and brakes, determine the cause and carry out action as required, according to the following general troubleshooting items.

(NOTICE)

- When checking whether or not the pressure is correct, refer to the pressure standard value for each hydraulic circuit.

3-2-1. Machine moves neither forward nor backward 1/2

Check point	Cause	Check/Action
1. Oil Level of Hydraulic Oil Tank	Oil level in hydraulic oil tank is low.	Fill tank until correct oil level is obtained.
2. Bypass Valve	Bypass valve is open.	Close bypass valve.
3. F-R Lever Linkage	F-R lever linkage is faulty.	Check and adjust F-R lever linkage or replace it if necessary.
4. Charge Circuit Pressure	Propulsion pump does not discharge oil because charge pressure is low.	<ul style="list-style-type: none"> • Measure charge pressure. • If low, check and adjust charge relief valve or replace it if necessary.
	Charge pressure decreases due to pressure leakage from cut off valve.	Check and adjust cut off valve or replace it if necessary.
	Insufficient steering • charge pump discharge.	Repair steering • charge pump or replace it if necessary.
	Charge pressure decreases due to internal leakage of solenoid valve connecting oil supply circuit with charge circuit. <ul style="list-style-type: none"> • Parking brake solenoid valve • Speed change solenoid valve 	<ul style="list-style-type: none"> • When solenoid is energized, check if oil flows in return circuit to tank. • If oil is flowing, repair solenoid valve or replace it if necessary.
5. Servo Bypass Solenoid Valve	If spool of servo bypass solenoid valve is stuck, pressure in both sides of servo cylinder chamber is equalized. This causes propulsion pump unable to discharge oil.	<ul style="list-style-type: none"> • Measure pressure in servo cylinder chambers. • If pressure is equal in both chambers, repair servo bypass solenoid valve or replace it if necessary.
6. Suction Filter for Steering • Charge Pump	Steering • charge pump flow is reduced due to clogged filter.	Clean suction filter or replace it if necessary.
7. Propulsion Circuit Pressure	Pump does not discharge oil because setting pressure of cut off valve is low.	<ul style="list-style-type: none"> • Measure propulsion circuit pressure. • If low, check and adjust cut off valve or replace it if necessary.
	Circuit does not obtain required pressure because setting pressure of high pressure relief is low.	<ul style="list-style-type: none"> • Measure propulsion circuit pressure. • If low, check and adjust high pressure relief valve or replace it if necessary.
8. Propulsion Motor	Propulsion circuit pressure is not held in propulsion motor case.	If pressure in propulsion motor case is not within allowable range, repair propulsion motor or replace it if necessary.
	Internal leakage of propulsion motor.	<ul style="list-style-type: none"> • Measure drain quantity from propulsion motor. • If drain quantity is larger than standard value, repair propulsion motor or replace it if necessary.
9. Gear Box	Sticking of disc brakes causes brakes to remain applied.	<ul style="list-style-type: none"> • Replace disc brakes.

CLICK HERE TO **DOWNLOAD** THE COMPLETE MANUAL

- Thank you very much for reading the preview of the manual.
- You can download the complete manual from: www.heydownloads.com by clicking the link below



- Please note: If there is no response to CLICKING the link, please download this PDF first and then click on it.

CLICK HERE TO **DOWNLOAD** THE COMPLETE MANUAL