

SHOP MANUAL

WH609-1E0 **WH613-1E0**
WH713-1E0 **WH714H-1E0**
WH716-1E0

TELESCOPIC HANDLER

MODEL	SERIAL NUMBER
WH609-1E0	395F61003 and up
WH613-1E0	395F61003 and up
WH713-1E0	395F71003 and up
WH714H-1E0	395F71003 and up
WH716-1E0	395F71003 and up

CLICK HERE TO **DOWNLOAD** THE COMPLETE MANUAL

- Thank you very much for reading the preview of the manual.
- You can download the complete manual from: www.heydownloads.com by clicking the link below



- Please note: If there is no response to CLICKING the link, please download this PDF first and then click on it.

CLICK HERE TO **DOWNLOAD** THE COMPLETE MANUAL

HOISTING INSTRUCTIONS

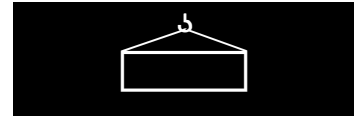

⚠ Heavy parts (25 kg or more) must be lifted with a hoist etc. In the Disassembly and Assembly section, every part weighing 25 kg or more is clearly indicated with the symbol 

- If a part cannot be smoothly removed from the machine by hoisting, the following checks should be made:
 - Check for removal of all bolts fastening the part to the relative parts.
 - Check for any part causing interference with the part to be removed.

2. Wire ropes

- Use adequate ropes depending on the weight of parts to be hoisted, referring to the table below:

WIRE ROPES (Standard «S» or «Z» twist ropes without galvanizing)	
Rope diameter (mm)	Allowable load (tons)
10.0	1.0
11.2	1.4
12.5	1.6
14.0	2.2
16.0	2.8
18.0	3.6
20.0	4.4
22.4	5.6
30.0	10.0
40.0	18.0
50.0	28.0
60.0	40.0

The allowable load value is estimated to be one-sixth or one-seventh of the breaking strength of the rope used.

- Sling wire ropes from the middle portion of the hook. Slings near the edge of the hook may cause the rope to slip off the hook during hoisting, and a serious accident can result.

Hooks have maximum strength at the middle portion.

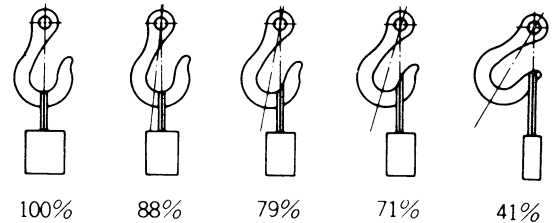

- Do not sling a heavy load with one rope alone, but sling with two or more ropes symmetrically wound on to the load.

⚠ Slings with one rope may cause turning of the load during hoisting, untwisting of the rope, or slipping of the rope from its original winding position on the load, which can cause dangerous accidents.

- Do not sling a heavy load with ropes forming a wide hanging angle from the hook.

When hoisting a load with two or more ropes, the force subjected to each rope will increase with the hanging angles.

The table below shows the variation of allowable load (kg) when hoisting is made with two ropes, each of which is allowed to sling up to 1000 kg vertically, at various hanging angles.

When two ropes sling a load vertically, up to 2000 kg of total weight can be suspended.

This weight becomes 1000 kg when two ropes make a 120° hanging angle.

On the other hand, two ropes are subjected to an excessive force as large as 4000 kg if they sling a 2000 kg load at a lifting angle of 150°.

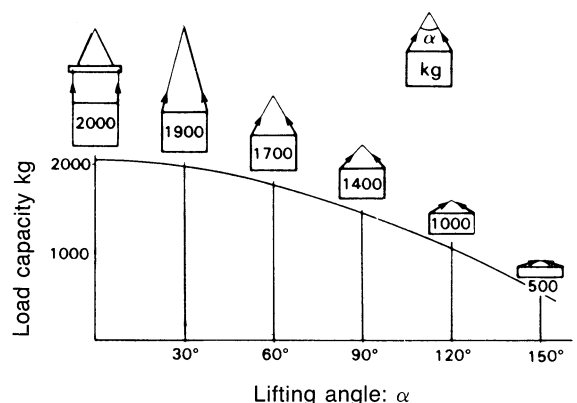

From liter to U.S. Gall.

1 ℓ = 0.2642 U.S. Gall.

	0	1	2	3	4	5	6	7	8	9
0	0	0.264	0.528	0.793	1.057	1.321	1.585	1.849	2.113	2.378
10	2.642	2.906	3.170	3.434	3.698	3.963	4.227	4.491	4.755	5.019
20	5.283	5.548	5.812	6.076	6.340	6.604	6.869	7.133	7.397	7.661
30	7.925	8.189	8.454	8.718	8.982	9.246	9.510	9.774	10.039	10.303
40	10.567	10.831	11.095	11.359	11.624	11.888	12.152	12.416	12.680	12.944
50	13.209	13.473	13.737	14.001	14.265	14.529	14.795	15.058	15.322	15.586
60	15.850	16.115	16.379	16.643	16.907	17.171	17.435	17.700	17.964	18.228
70	18.492	18.756	19.020	19.285	19.549	19.813	20.077	20.341	20.605	20.870
80	21.134	21.398	21.662	21.926	22.190	22.455	22.719	22.983	23.247	23.511
90	23.775	24.040	24.304	24.568	24.832	25.096	25.361	25.625	25.889	26.153

From liter to U.K. Gall.

1 ℓ = 0.21997 U.K. Gall.

	0	1	2	3	4	5	6	7	8	9
0	0	0.220	0.440	0.660	0.880	1.100	1.320	1.540	1.760	1.980
10	2.200	2.420	2.640	2.860	3.080	3.300	3.520	3.740	3.950	4.179
20	4.399	4.619	4.839	5.059	5.279	5.499	5.719	5.939	6.159	6.379
30	6.599	6.819	7.039	7.259	7.479	7.699	7.919	8.139	8.359	8.579
40	8.799	9.019	9.239	9.459	9.679	9.899	10.119	10.339	10.559	10.778
50	10.998	11.281	11.438	11.658	11.878	12.098	12.318	12.528	12.758	12.978
60	13.198	13.418	13.638	13.858	14.078	14.298	14.518	14.738	14.958	15.178
70	15.398	15.618	15.838	16.058	16.278	16.498	16.718	16.938	17.158	17.378
80	17.598	17.818	18.037	12.257	18.477	18.697	18.917	19.137	19.357	19.577
90	19.797	20.017	20.237	20.457	20.677	20.897	21.117	21.337	21.557	21.777

TRANSMISSION

DIAGRAM OF THE POWER TRAIN

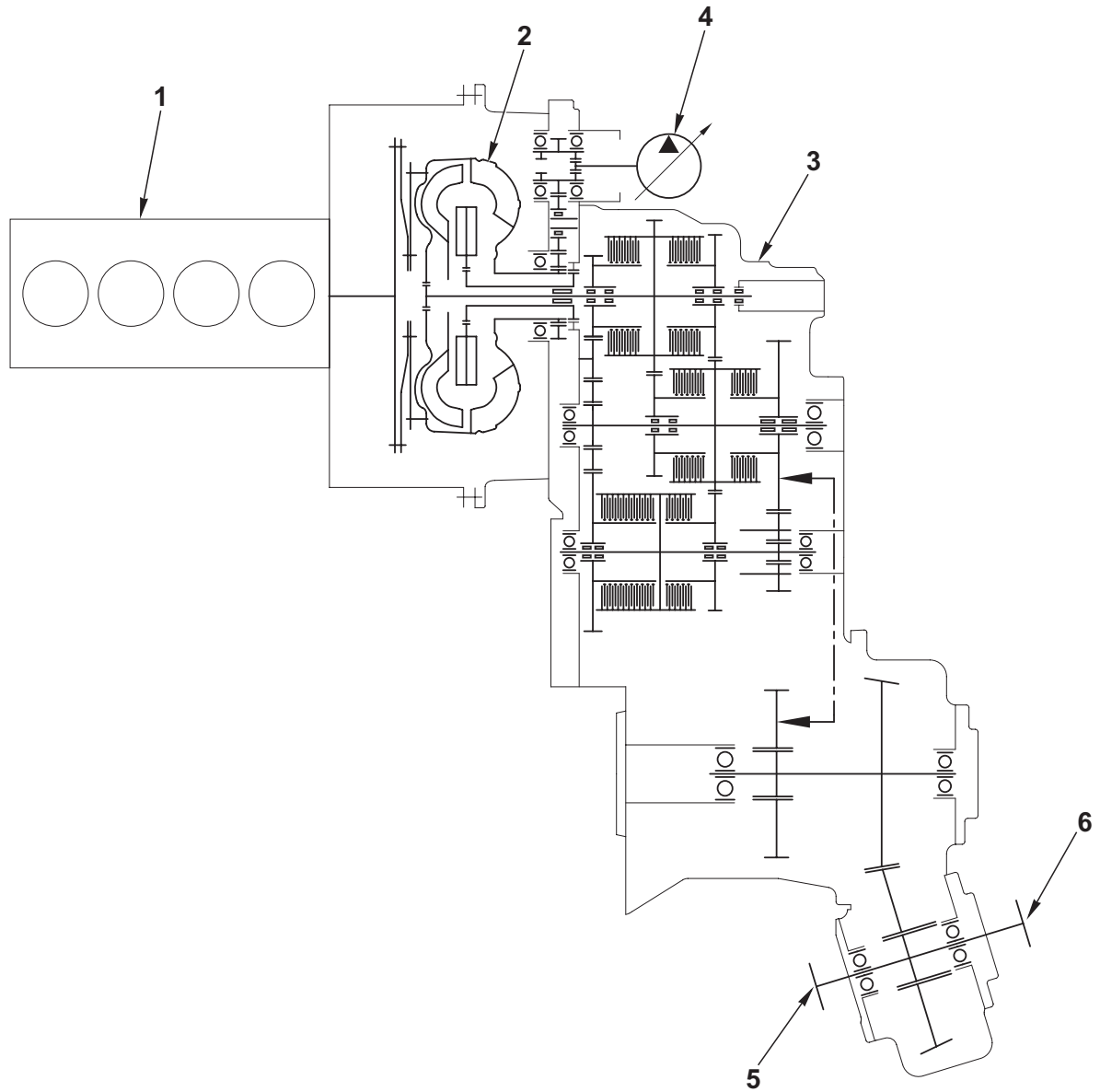

RKT00040

- 1. Engine
- 2. Converter
- 3. Transmission
- 4. Hydraulic pump
- 5. Rear flange
- 6. Front flange

1.3 Clutches

- Once a directional clutch is engaged, power is transmitted to the range clutches (1st, 2nd, 3rd or 4th High).
- Operation and actuation of the range clutches is similar to the directional clutches.
- The engagement of the range clutches is not modulated.

1.4 Output section

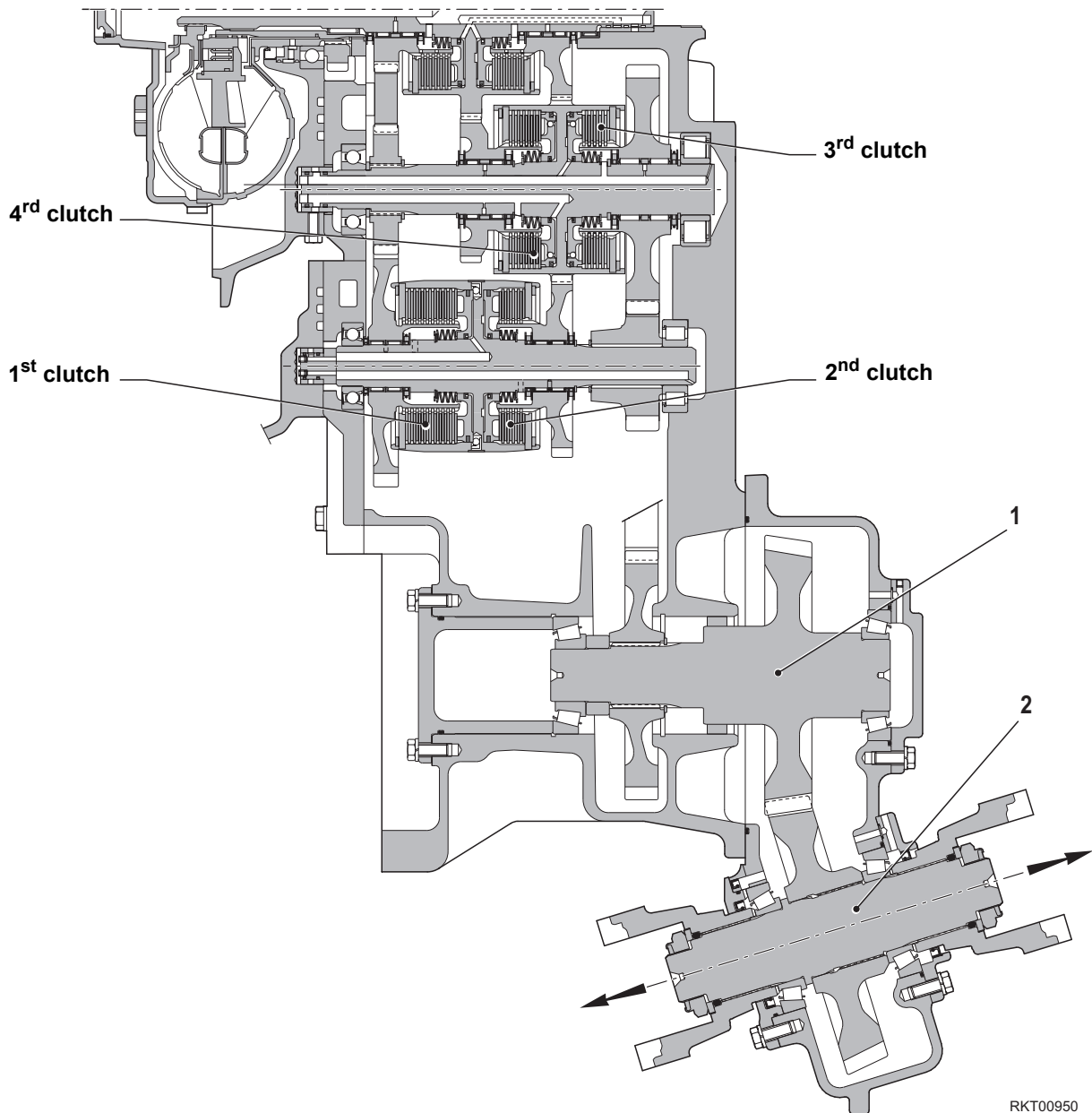

RKT00950

- Once a range clutch is engaged, power is transmitted to the output shaft. Output rotation is the same as engine rotation.
- The output shaft transmits motion to the drop box gears (1) and (2) which in turn transmit motion to the transmission shafts connected to the axles.

- FORWARD 4th SPEED

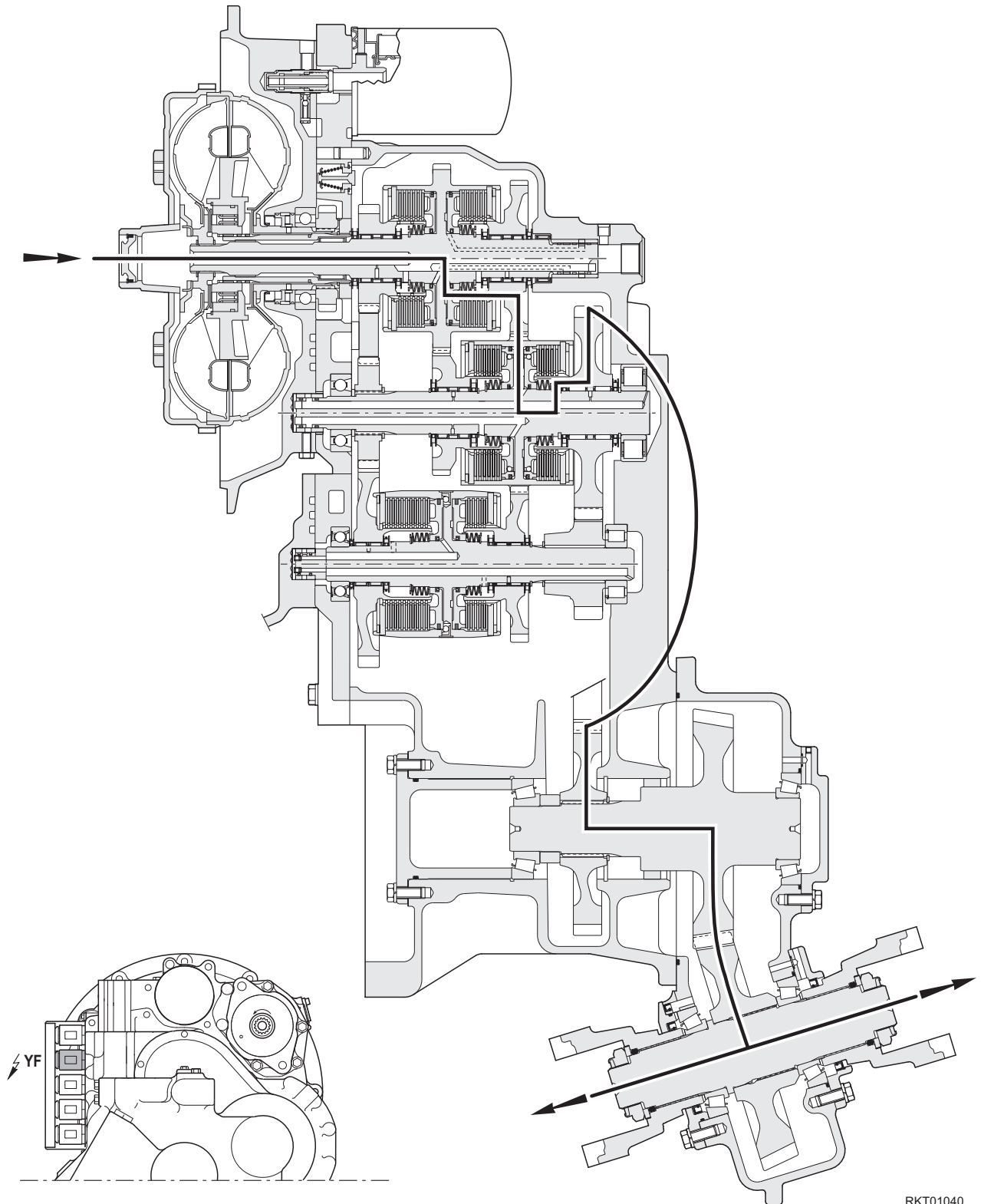

RKT01040

REAR AXLE

CENTRE BODY

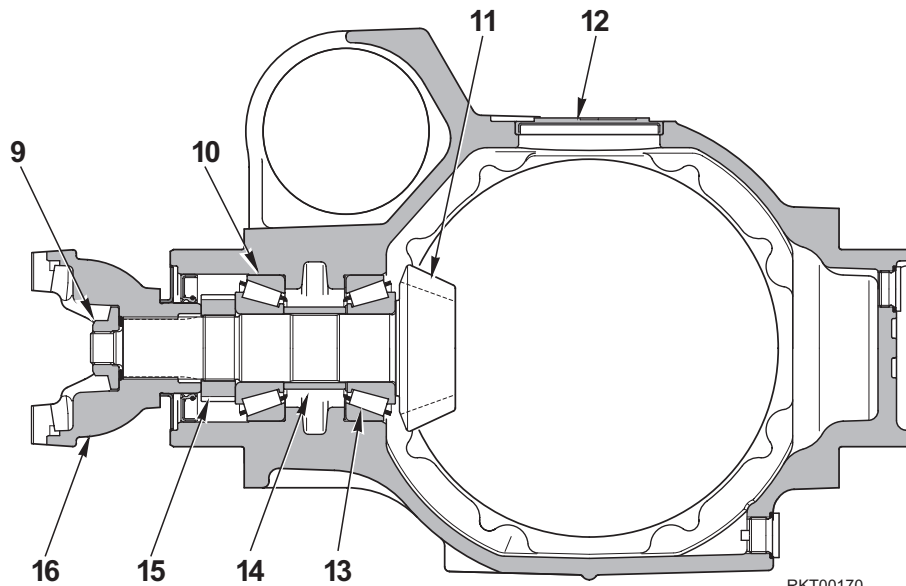
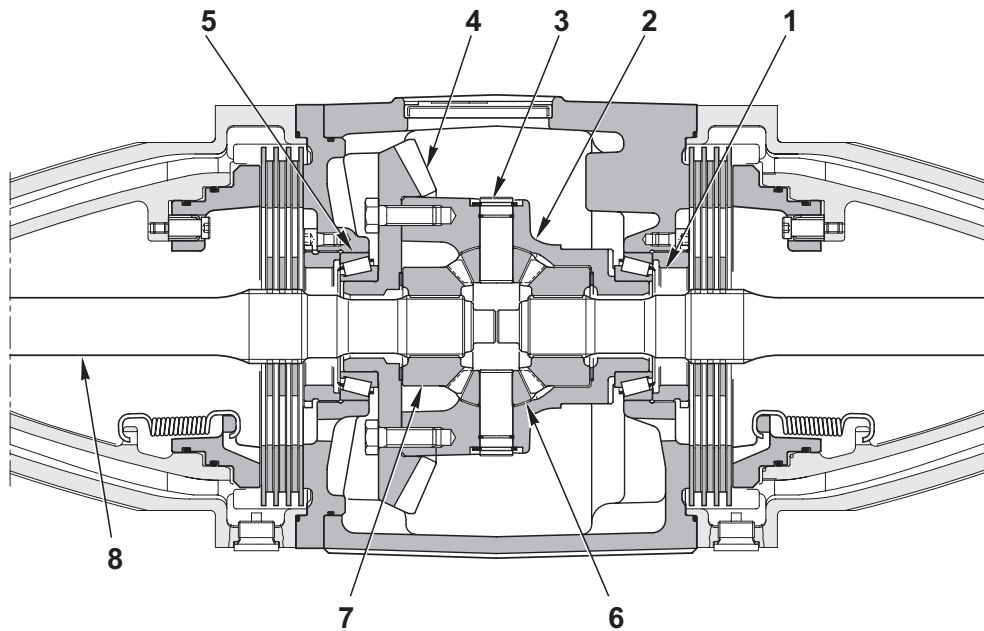

RKT00170

- | | |
|-------------------------|--------------|
| 1. Ring nut | 11. Pinion |
| 2. Differential housing | 12. Plug |
| 3. Pin | 13. Bearing |
| 4. Ring gear | 14. Spacer |
| 5. Bearing | 15. Ring nut |
| 6. Planetary gear | 16. Flange |
| 7. Side gear | |
| 8. Drive shaft | |
| 9. Nut | |
| 10. Bearing | |

CHARACTERISTICS:

- **Version with aspirated engine**
Amount of oil: 7.0 ℓ
Reduction ratio: 8:31
- **Version with turbo engine**
Amount of oil: 7.1 ℓ
Reduction ratio: 9:31

HYDRAULIC DIAGRAM

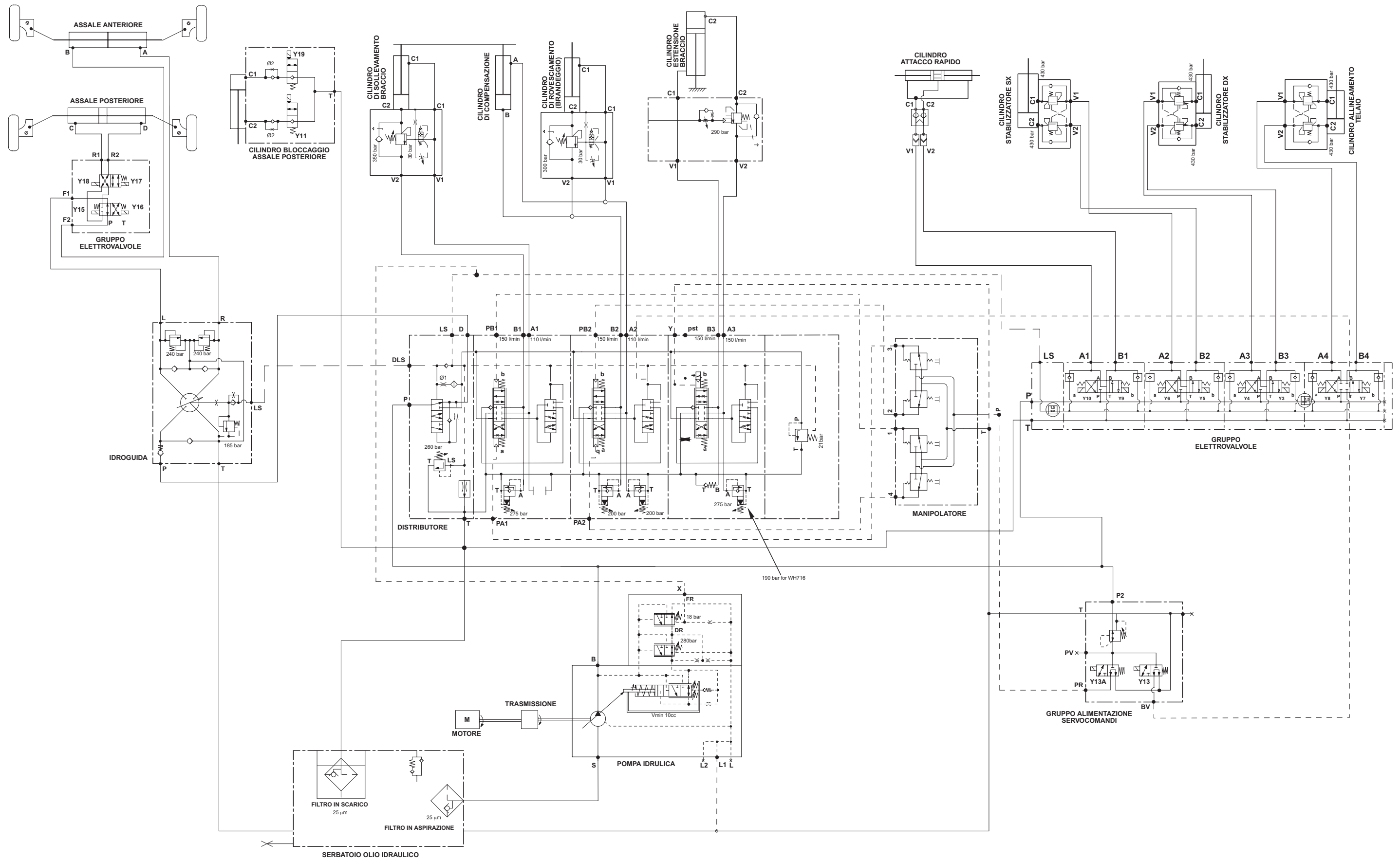

RKT02020

ST1 STEERING SOLENOID VALVE GROUP (Y15 - Y16 - Y17 - Y18)

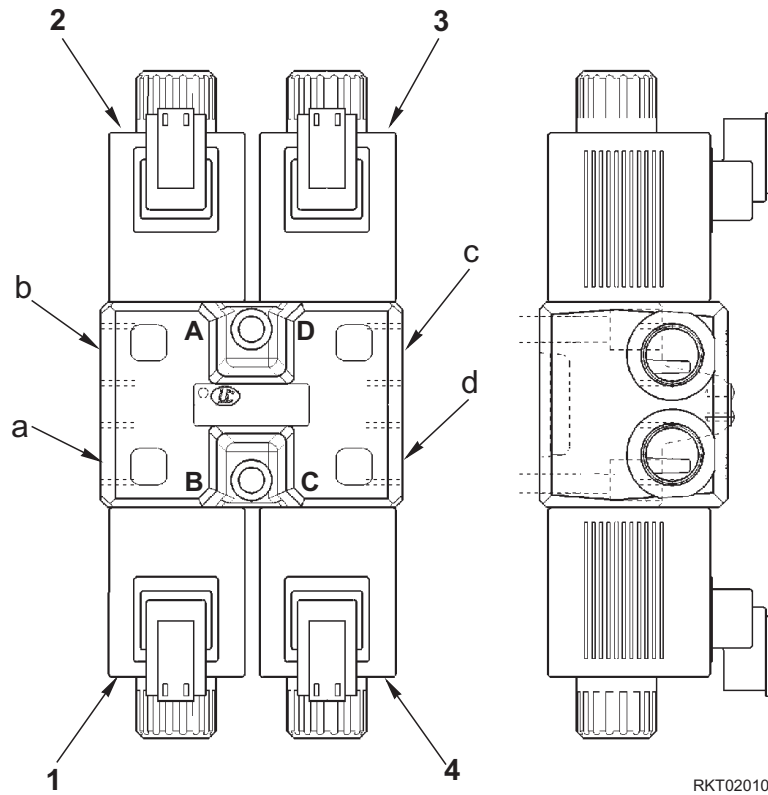

- 1. Y16 - Front/rear steering
- 2. Y15 - Rear steering cut out
- 3. Y17 - Phase coincidence steering
- 4. Y18 - Crab steering
- 5. Port block

- a. F2 Port - To front axle steering cylinder (B Port)
- b. F1 Port - From steering unit (L Port)
- c. R1 Port - To rear axle steering cylinder (D Port)
- d. R2 Port - To rear axle steering cylinder (C Port)

FRAME LEVELLING

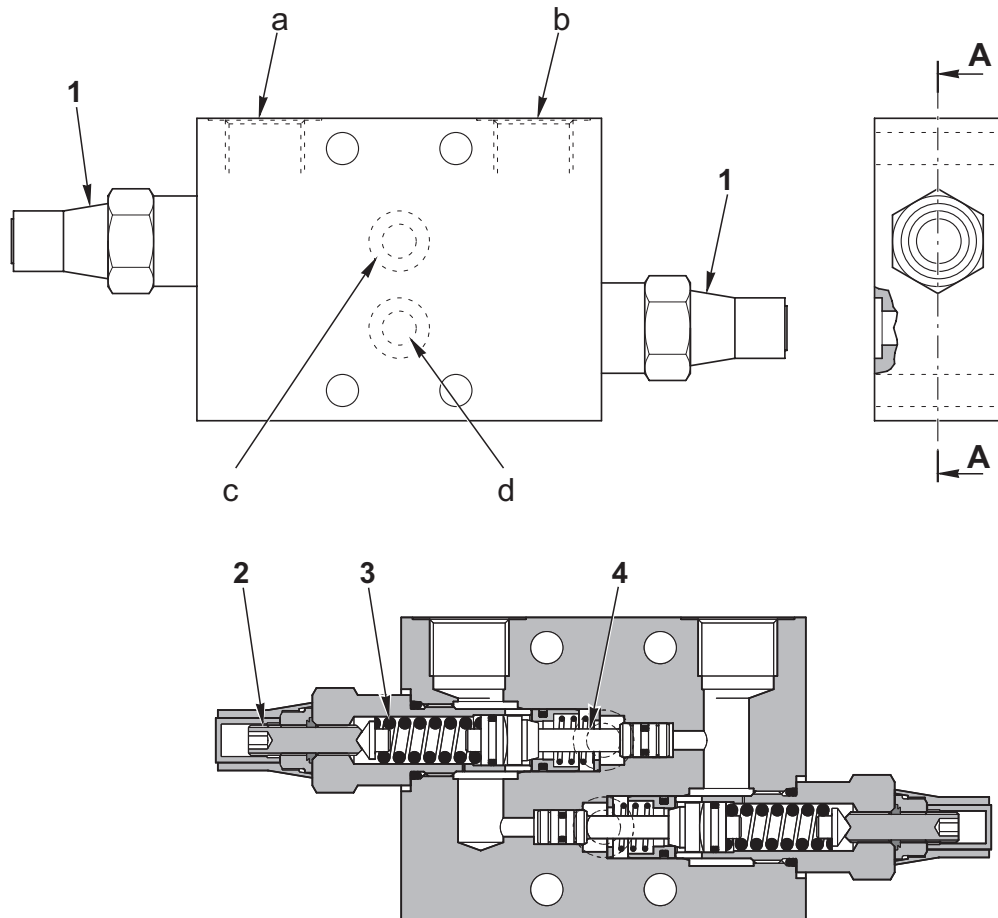

Section A - A

RKT00580

- 1. Safety valve
- 2. Adjusting screws
- 3. Spring
- 4. Valve

CHARACTERISTICS

Safety valve calibration: 430 bar

- a. V2 Port - From OP2 OP4 solenoid valve group (B2 Port)
- b. V1 Port - From OP2 OP4 solenoid valve group (A2 Port)
- c. C2 Port - To frame levelling cylinder (base side)
- d. C1Port - To frame levelling cylinder (head side)

CLIMATE CONTROL SYSTEM OPERATION

The compressor (1) is driven directly by the crankshaft by means of a belt, and is caused to rotate by a pulley fitted with an electromagnetically-engaged clutch (1a).

A thermostatic sensor (7) controls the engagement and disengagement of the clutch. It disengages the clutch when the evaporator reaches the lower temperature limit and engages the clutch when the evaporator reaches the upper temperature limit.

The coolant fluid (in gaseous phase) is drawn into the compressor where it is subjected to compression and an intense heating process. In these conditions the fluid is then sent into the condenser (2) where, due to the heat extracted by ambient temperature air flowing over fins, it reaches condensation temperature, and passes into a high-pressure liquid state.

Subsequently the coolant passes into the drying-filter assembly (3) which performs three functions: it filters out impurities, absorbs any moisture present in the circuit and, finally, also functions as a reserve tank.

The coolant in its liquid state is then transferred to the evaporator (6), first passing through an expansion valve (5). The task of this valve is the constant metering of the quantity of fluid in order to maintain optimum evaporation.

In the evaporator the coolant fluid is subjected to expansion, bringing it up to the critical evaporation point at a temperature of approximately -8°C .

The flow of air generated by centrifugal fan (8), which passes through the evaporator (6) at ambient temperature is considerably warmer than -8°C . For this reason it yields heat to the coolant fluid, bringing it up to boiling point and complete evaporation.

On leaving the evaporator (6) the coolant is drawn once more into the compressor (1) and a new cycle commences.

The extraction of heat from the atmosphere in which the evaporator is positioned leads to the condensation of the water suspended in the air, and hence to dehumidification. The condensate is deposited on the evaporator fins where, if a temperature higher than 0°C is not maintained, it freezes and inhibits the functioning of the evaporator.

The task of keeping the temperature of the evaporator above 0°C (and thus within the optimum limits for heat exchange) is entrusted to a thermostatic sensor (7).

The condensate that forms on the evaporator fins (6) also contains dust, pollens and particles suspended in the air. Continual condensation therefore effectively purifies the air, and the droplets of condensate are discharged to the exterior.

A fixed quantity of anti-freeze oil is also introduced into the circuit, with the function of lubricating all the mechanical parts of the A/C system. A percentage of this oil circulates constantly throughout the A/C system in atomised form, lubricating the compressor (pistons and bearings) and the expansion valve.

A pressure switch (4) has been inserted in the electrical control circuit to protect the A/C system in the case of a lack of coolant fluid or if the quantity becomes insufficient due to leakages. This switch will inhibit the engagement of the electromagnetic clutch and hence the functioning of the air-conditioning system.

• MACHINE MODEL WH609

Machine model				WH609		
Classification	Check item	Test conditions	Unit	Standard value	Permissible value	
Translation speed	Translation speed (no load)	<ul style="list-style-type: none"> • Wheels lifted with stabilizers and/or jack stands: see Figures E and F in this chapter. • Check engine at MAX rpm • Transmission oil temperature at 60-70 °C • Measure propeller shaft speed in all gears. 	FORWARD GEAR 1	m/1'	570	513–621
			2		1243	1119–1355
			3		1889	1700–2059
			4		2550	2295–2780
			5		3863	3477–4211
			REVERSE GEAR 1		570	513–621
			2		1243	1119–1355
			3		2550	2295–2780

• MACHINE MODEL WH713

Machine model				WH713		
Classification	Check item	Test conditions	Unit	Standard value	Permissible value	
Translation speed	Translation speed (no load)	<ul style="list-style-type: none"> Wheels lifted with stabilizers and/or jack stands: see Figures E and F in this chapter. Check engine at MAX rpm Transmission oil temperature at 60-70 °C Measure propeller shaft speed in all gears. 	FORWARD GEAR 1	m/1'	570	513–621
			2		1243	1119–1355
			3		1889	1700–2059
			4		2550	2295–2780
			5		3863	3477–4211
			REVERSE GEAR 1		570	513–621
			2		1243	1119–1355
			3		2550	2295–2780

• MACHINE MODEL WH716

Machine model				WH716		
Classification	Check item	Test conditions	Unit	Standard value	Permissible value	
Translation speed	Translation speed (no load)	<ul style="list-style-type: none"> Wheels lifted with stabilizers and/or jack stands: see Figures E and F in this chapter. Check engine at MAX rpm Transmission oil temperature at 60-70 °C Measure propeller shaft speed in all gears. 	1	m/1'	570	513–621
			2		1243	1119–1355
			3		1889	1700–2059
			4		2550	2295–2780
			5		3863	3477–4211
			1		570	513–621
			2		1243	1119–1355
			3		2550	2295–2780

TENSIONING THE AIR CONDITIONER COMPRESSOR BELT

1 -Loosen the screw (1) and nut (2).

2 -Turn the screw (3) clockwise to tension the belt (4).

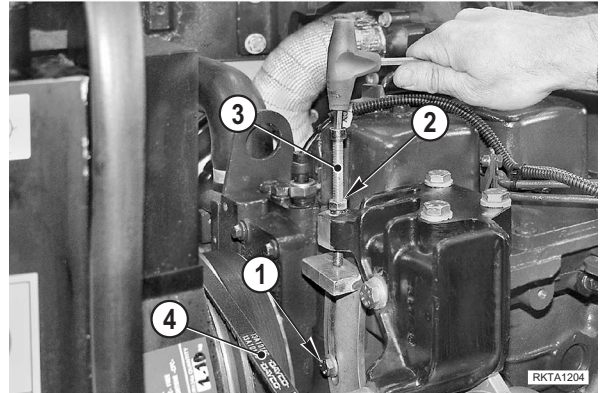

3 -Apply a 10 kg force at the centre of the segment from compressor pulley (5) to engine pulley (6).

4 -Check the resulting "F" arrow.

- ★ F = 4-6 mm (normal tension)
- F = 3 mm (new belt)

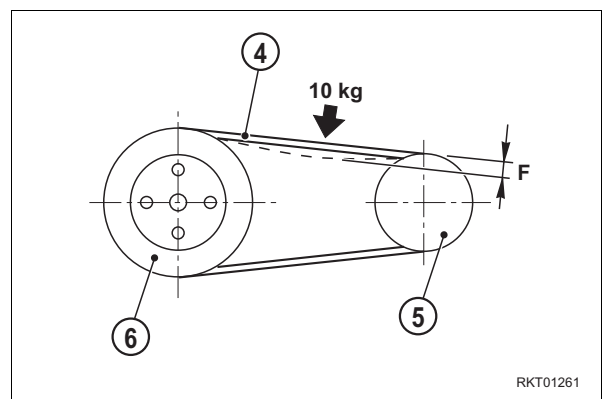

5 -Once proper tension is achieved, retain the position of the adjusting screw (3) by tightening the nut (2).

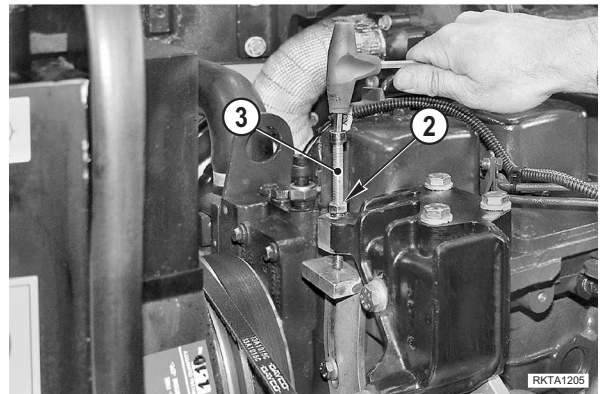

6 -Lock the adjusting bracket (7) with the screw (1).

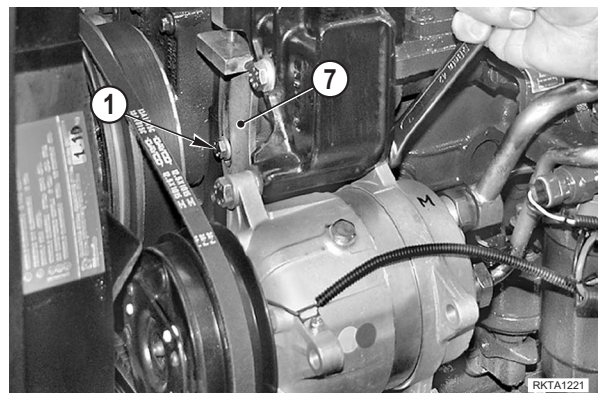

1. CALIBRATION CHECK GENERAL VALVE (Cut-off valve)

★ Check conditions:

- Engine: at operating temperature
- Hydraulic oil 50 ± 5 °C
- Parking brakes: applied

1 -Connect a 600 bar pressure gauge to the pressure tap (1) of the control valve (2).

2 -Start the engine and run it at IDLE and check the calibration pressure of the cut-off (general) valve while forcing the boom down to the end of its travel.

★ Calibration pressure: 260 ± 7 bar

3 -Using the same method as above, also check calibration pressure with the engine running at 2000 rpm.

★ Max allowable variation: 5 bar

★ If general valve pressure does not match the specified value, perform the calibration procedure. (For details, please refer to "3. GENERAL AND SECONDARY VALVE CALIBRATION").

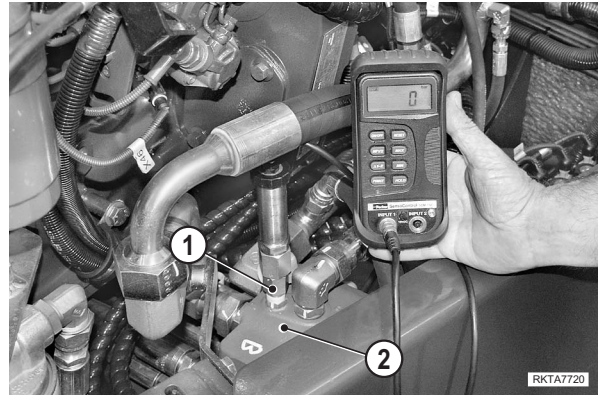

2. SECONDARY VALVE CALIBRATION CHECK

• Boom lift and extension

★ Check conditions:

- Engine: at operating temperature
- Hydraulic oil: 50 ± 5 °C
- Parking brake applied

★ All pressure readings are taken at the same check point.

1 -Connect a 400 bar pressure gauge to the pressure tap (1) of the control valve (2).

2 -Remove the general valve seal (3), loosen the nut (4) and tighten the pressure regulating screw (5) by 2 turns. Lock the nut (4).

3 -Start the engine and run it at IDLE; perform a full boom lift motion and measure max pressure.

★ Normal pressure: 275 ± 7 bar.

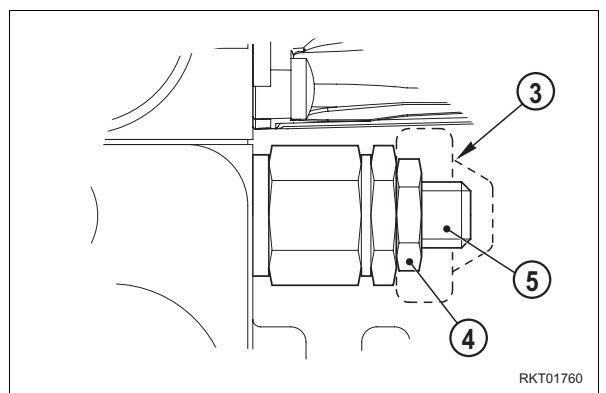
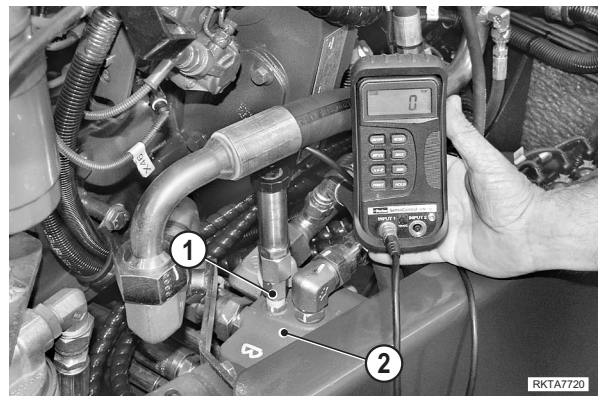

BRAKE SYSTEM CHECKS

★ Check conditions:

- Engine: stopped
- Machine: on firm level ground, with stabilizers fully extended. If the machine is not equipped with stabilizers, place wedges under the wheels.

The brake system checking procedure consists of two steps:

- 1 -Inspecting the circuit and brake pumps for leaks.
- 2 -Inspecting the brake units for leaks.

⚠ If both inspections yield positive results, the system lines should be checked for leaks.

• Inspecting the circuit and brake pumps for leaks.

⚠ Carry out the inspection on both front and rear brakes.

- 1 -Disconnect the relevant brake feed hose (2) from the brake pump (1).
- 2 -Install a pressure tap (3) connected to a 250 bar pressure gauge between the pump fitting (1) and the feed hose (2).
- 3 -Start the engine and operate it at IDLE, press the brake pedal and pressurize the circuit to 120 bar.

★ Do not exceed the maximum pressure allowed, which is 150 bar.

- 4 -Hold the pressure on the pedal for at least two minutes and check that the pedal pressure and position remain steady.

★ If the position of the pedal needs to be changed in order to hold the pressure, then the loss of pressure is to be blamed on a blow-by condition inside the pump.

Proof of this can be had by checking the oil in the tank. If there is blow-by, the oil will be stirred.

- 5 -Repeat the same steps on the other brake pump.

• Inspecting the brake units for leaks

- 1 -Disconnect the feed hose (1) and remove the pipe (2).

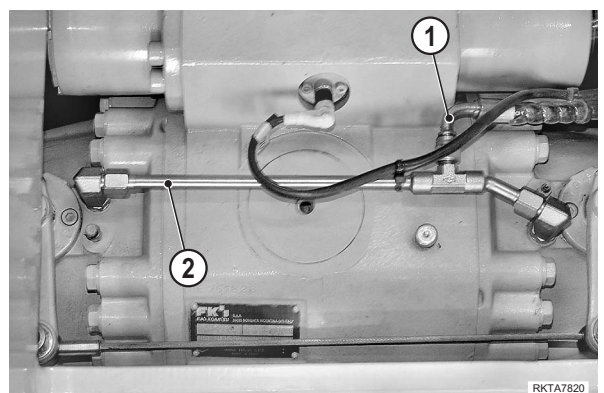
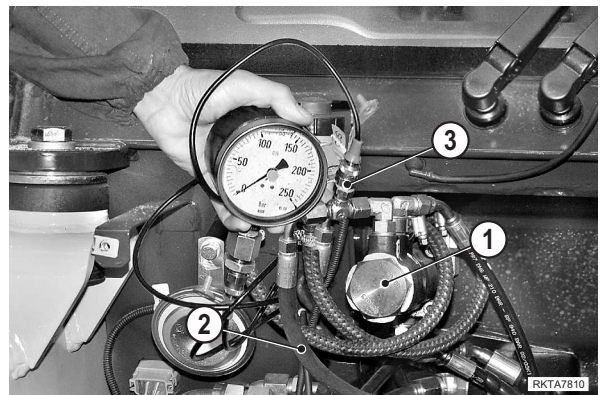

CHECKING LOAD CELL CALIBRATION

★ Check conditions:

- Frame perfectly levelled.
- Tires at prescribed pressure.
- Machine on firm level ground, with standard forks installed.

1 -Disconnect the connector (1). Between the load cell and the wiring, place an extension lead A with two sockets for plugging the pins of tester B.

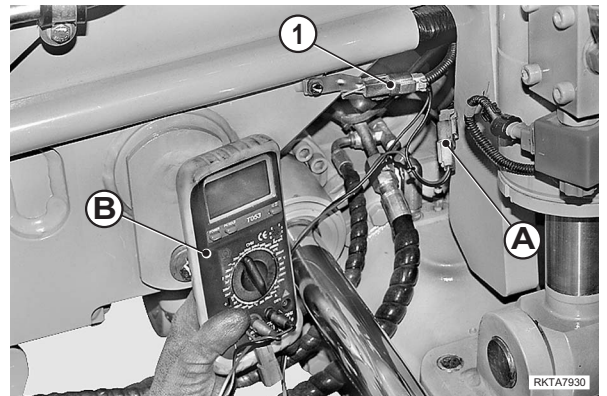

1. Checking load signal with no load

- 1 -Using a level C, position the basic boom parallel to the ground.
- 2 -Ensure the forks are raised but parallel to the ground.
- 3 -Check the signal emitted by the load cell.

★ Normal signal: 30–35 mA



2. Checking load signal in turnover conditions

- 1 -Place the specified weight "P" on the forks and extend the boom until the rear wheels lift off the ground by about 10 cm.

MACHINE	P
WH 609	2000 kg
WH613 - WH 713 - WH716 - WH714H	1000 kg

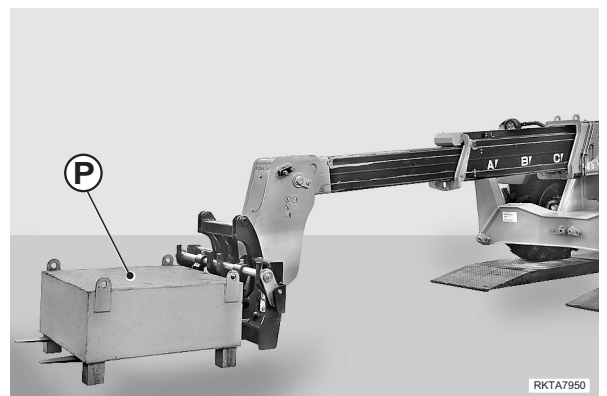

- 2 -Check the signal emitted by the load cell.

★ Normal signal: 35–45 mA.

⚠ If the signal emitted by the load cell is not within standard values, replace the load cell.



6 -Using the same criteria, check clearances between front sliding pads from the basic to the intermediate boom.

★ Normal clearances are the same as specified in steps 3 and 5.

7 -After the inspection, install any removed parts and perform a full lubrication procedure.



NOTES

1 -If total clearance exceeds the maximum acceptable value, replace all the sliding pads.
(For details, refer to "30 REMOVAL AND INSTALLATION").

2 -If total clearance exceeds the maximum allowable value, a shim (1 mm) can be added to the lower sliding pad.
Beyond this limit, replace the upper and lower sliding pads.
(For details, please refer to "30 REMOVAL AND INSTALLATION").

CHECKING FOR BLOW-BY

★ Check conditions:

- No wind.
- Machine with standard forks attached, placed on firm, level ground with the parking brakes applied and the frame perfectly levelled.
- Boom fully lowered to the ground.
- Hydraulic oil temperature: 40 °C throughout the system, measured at the pump suction pipe.
- Tires at prescribed pressure.

1 -Place the specified weight “P” on the forks, and secure the weight to the equipment crate (2) with the chains (1).

MACHINE	P
WH 609 - WH613	3500 kg
WH 713	3700 kg
WH714H	4500 kg
WH 716	4000 kg

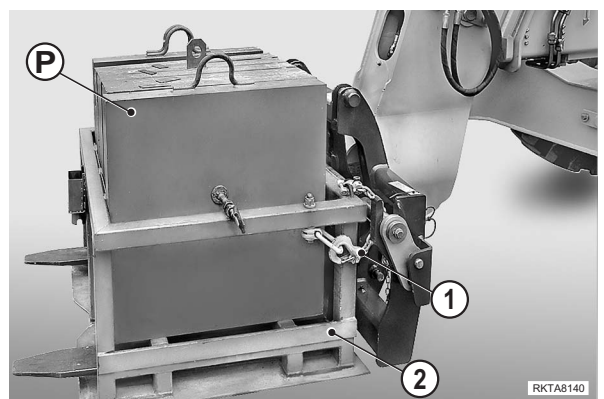

2 -Start the engine and fully lower the stabilizers to the ground.

3 -Place a fixed locator “A” to the stabilizer stem; note down locator distance in relation to the cylinder head.



4 -Secure a 20 m tape measure “B” to the end of the forks.

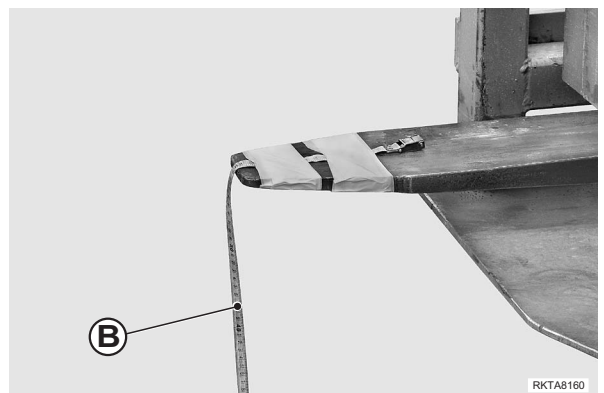

5 -Apply some adhesive tape “C” and measure and note down the length of the portion of the stem (4) between the tape “C” and the cylinder head (5).

6 -Check draining behaviour.

- If draining is noticed at the safety valve (1), the valve is faulty and needs to be replaced.
- If no draining occurs at the valve and the stem tends to retract in the following 10 minutes, then there is a blow-by condition inside the cylinder.

⚠ NOTICE!
Remove the adhesive tape previously applied to the stem in step 5.

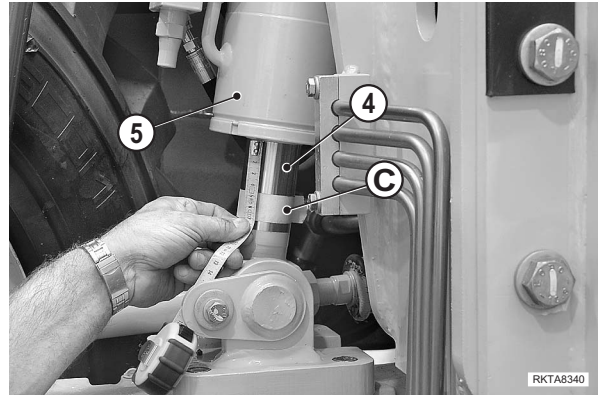

6. Checking procedure for axle locking cylinder

★ Check conditions:

- Machine on solid, level ground.
- Frame levelled.
- Boom fully retracted, raised above 50°, with no load.
- Engine not running.



1 -Disconnect connectors (1 and 2) from the solenoid valve group (3).

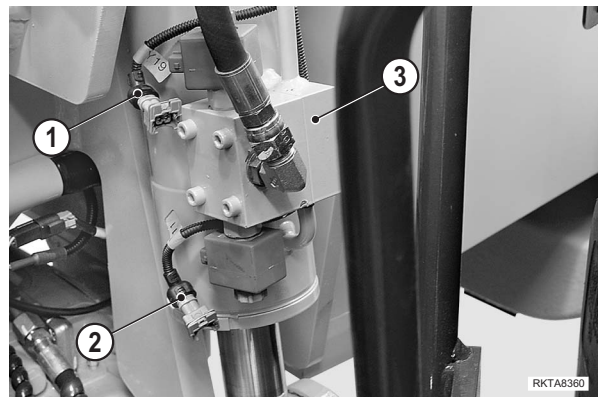

2 -Start the engine and drive the machine onto a raised platform “A” by about 8–10 cm with the sole rear left wheel.

3 -Apply the parking brakes and stop the engine.



HOW TO READ THE MANUAL

1. Removal and Installation of the groups

- (1) The procedures and information needed to carry out the work of removing or Installing units or groups are given in the removal procedure. The sequence of operations is not repeated in the installation procedure.
- (2) Information needed for installation is marked with the symbol [*1]; The same symbol is repeated at the end of each removal procedure for the same item, to indicate to which installation item it refers.

(Example)

REMOVAL GROUP ●●● : Title of operation

 : Safety precautions to be followed when carrying out the operation.

1 - Remove XXXX (1): Step in removal procedure.

★ : Technique or important point to remember when removing XXXX (1)

2 - ▲▲▲ (2): [*1] This sign means that information is given for the installation procedure

3 - Remove ■■■ (3):

 ℓ: Recovery of oil or water, and the quantity to be recovered.

INSTALLATION GROUP ●●● : Title of operation.

● To install, reverse removal procedure.

[*1]: Technique to be used for installation

★ : Technique or important point to remember when removing ▲▲▲ (2)

● Addition of water or oil: Step in removal procedure.





★: Point to remember when adding water or oil.

- 2. To the precautions to be taken during the removal or installation of the groups, must be added the specific "PRECAUTIONS TO BE TAKEN WHEN WORKING". Always make sure that these precautions are taken.

3. List of special tools.

- (1) For details of the descriptions, codes and quantities of each tool (A1; A2 etc.) mentioned in the operational procedures, see the list "SPECIAL TOOLS" supplied in this section.

4. List of the tightening torques and weights, and the quantities oil, liquids or grease needed to fill tanks and containers

- (1) In the operating procedures, you will find the symbols , , , , ; In the following order, these represent the values of «TIGHTENING TORQUES», «WEIGHT OF PARTS OR GROUPS», «QUANTITIES OF OIL OR LIQUIDS TO BE INTRODUCED», «SCREW LOCKING MATERIAL, SEALANTS AND LUBRICATION», «LUBRICATING GREASE».

NOTE

If no symbol is indicated, the values to be used are those given in the introductory sections of this manual.

ENGINE HOOD

Removal

1 -Lift the engine hood (1).



2 -While supporting the engine hood, loosen and remove the screws (2) retaining the hinges (3).

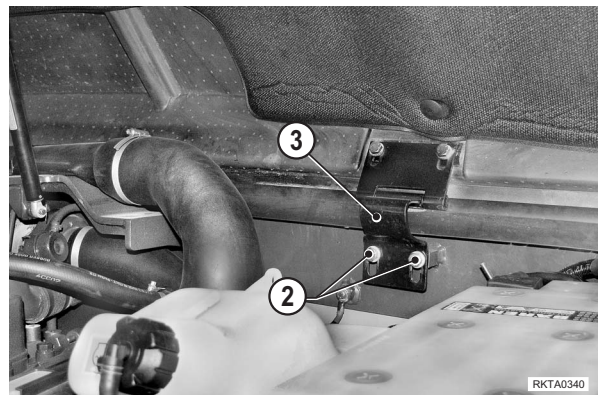

3 -Loosen and remove the self locking nut (4), the backing washer and the screw (5) to disconnect the gas damper (6) from its support (7).

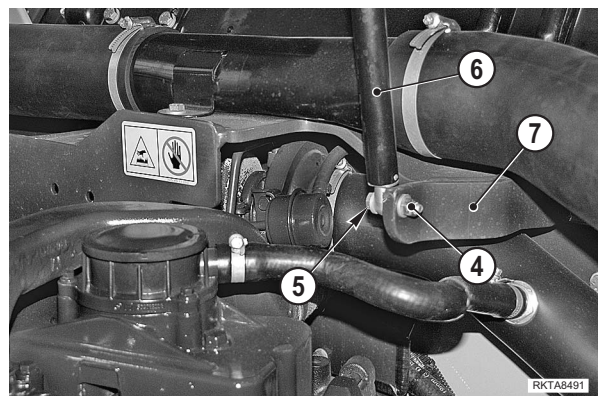

4 -Lower the hood and place an anti-slip block (A) between lower edge of hood and body; then, strap the hood and connect it a hoist.

5 -Remove the hood (1).

[*1]



RADIATOR-EXCHANGER ASSEMBLY

Removal

1 - Unscrew the cap (1) and drain the coolant liquid. [*1]



Coolant liquid: 20 ℓ approx.

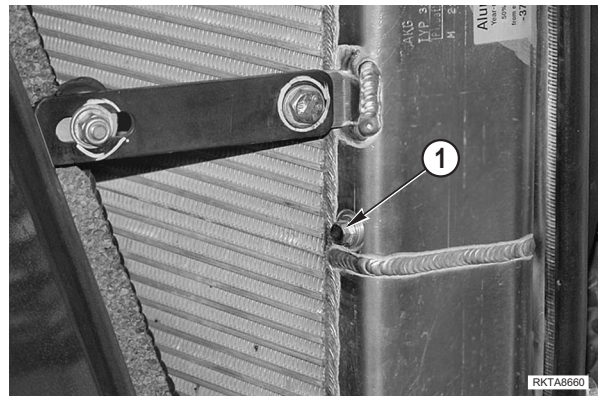

2 - Remove the radiator hood.
(For details, see "RADIATOR HOOD").

3 - Disconnect the hose (3) connecting to the expansion tank from the radiator cap (2). Remove the screw (4); remove the hose clamp (5), and slide the hose (3) out.

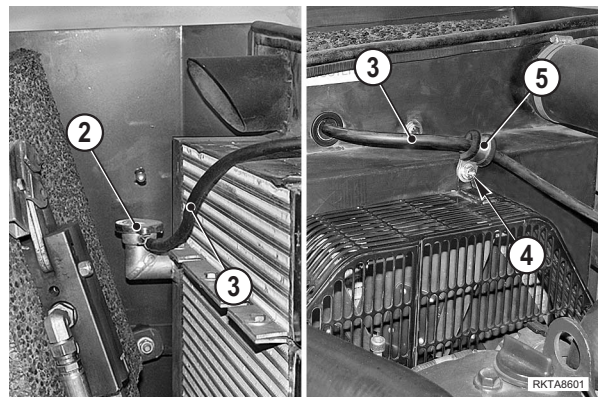

4 - Disconnect the hose (6) from the radiator-intercooler assembly and remove the hose.

5 - Remove the air inlet hose (7) and disconnect the turbocharger feed hose (8).

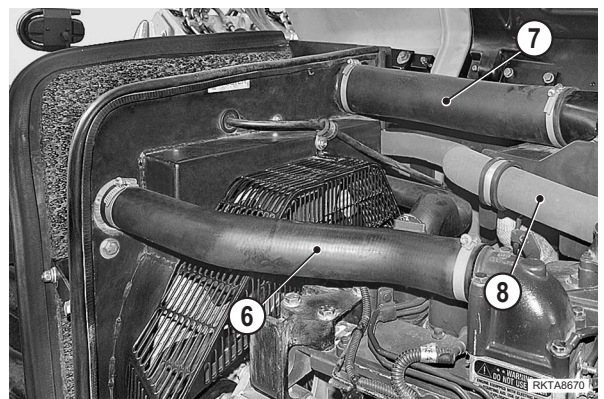

6 - Remove the retaining screws and remove the fan guard (9).

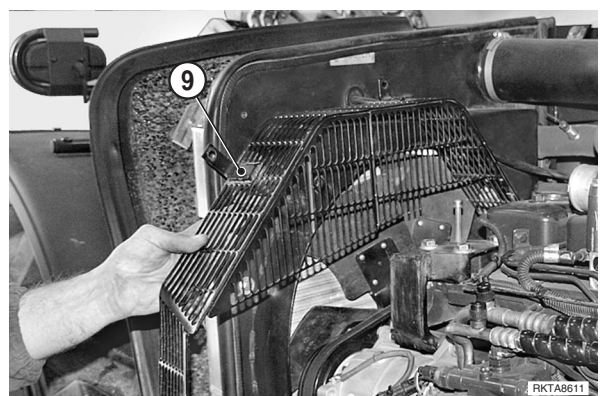

CLICK HERE TO **DOWNLOAD** THE COMPLETE MANUAL

- Thank you very much for reading the preview of the manual.
- You can download the complete manual from: www.heydownloads.com by clicking the link below



- Please note: If there is no response to CLICKING the link, please download this PDF first and then click on it.

CLICK HERE TO **DOWNLOAD** THE COMPLETE MANUAL

Installation

- Install the cylinder head by following the instructions given in the engine workshop manuals (code WEBMNEF001) and the reverse order for the parts connected to it.

1 -Carry out the coolant liquid filling procedure.



Coolant liquid: 20 ℓ approx.

28 -Disconnect the feed hose (49) connecting to the control valve, the servo-control feed assembly hose (50), and the solenoid valve block feed hose (51) from the tube (48).

- ★ Immediately cap the hoses and tube to prevent contaminants from entering the passages.

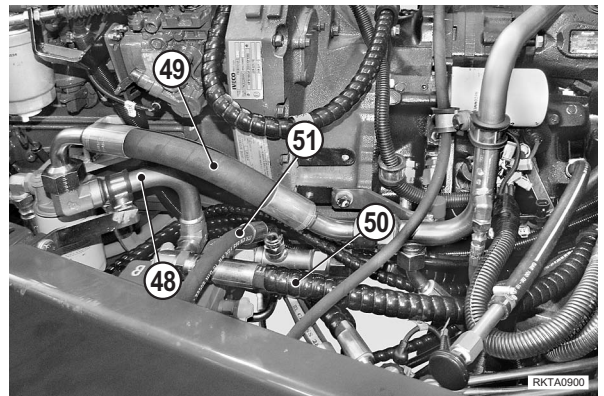

29 -Disconnect the pump housing drain hose (52) and the LS hose (53). [*4]



30 -Disconnect the brake pump servo-control feed hose (54) and the retaining clamp (55) from the transmission.

- ★ Immediately cap the hose to prevent contaminants from entering it.

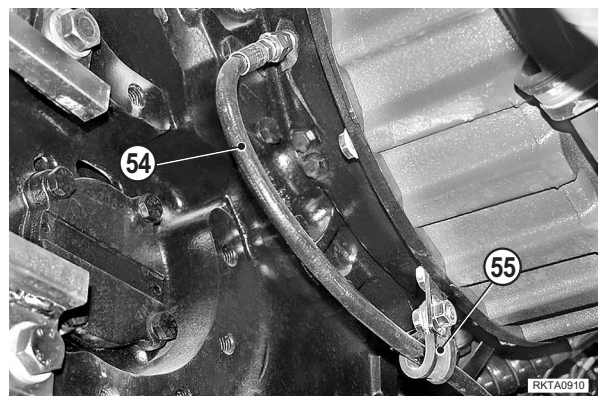

31 -Disconnect the brake pump servo-control drain hose (56) from the transmission.

- ★ Immediately cap the hose to prevent contaminants from entering it.

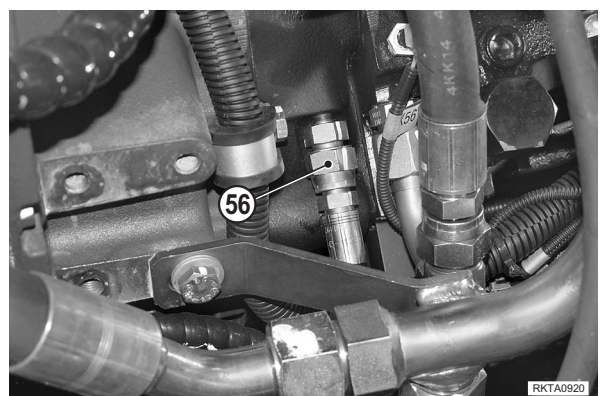

Installation

- To install, reverse the removal procedure.

[*1]

- ★ Fill the hydraulic oil reservoir to the maximum-fill level.



Hydraulic oil: 95 ℓ approx.

- 1 - Start the engine to allow the oil to circulate and check for any leaks.
Perform several motions to bleed the air from the system.
- 2 - Stop the engine, check the oil level and, if necessary, top it up.

- 3 -Loosen and remove the screws (3) and clevises (4);
disconnect the front propeller shaft (5). [*2]

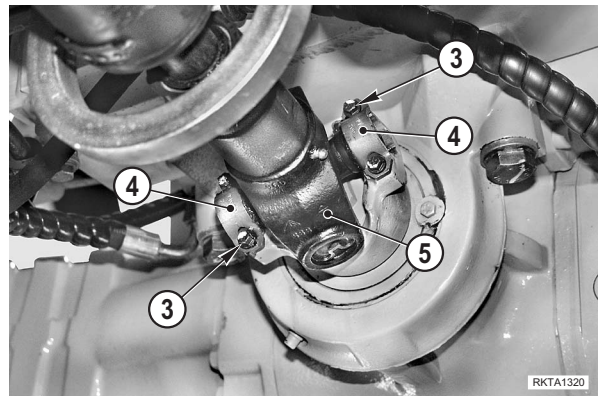

- 4 -Disconnect the hoses (7),(8) from the steering cylinder (6).

- ★ Cap the hoses and plug the holes to prevent contaminants from entering the passages.

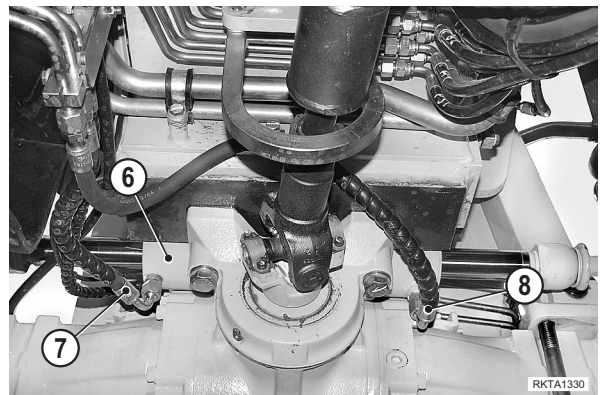

- 5 -Loosen and remove the parking brake adjustment nuts (9) and disconnect the control cable (10).

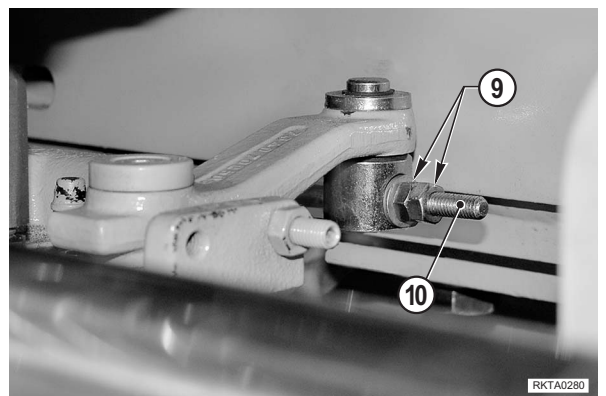

- 6 -Disconnect the service brake hose (11) and the wiring (12) of the steering sensor (13).

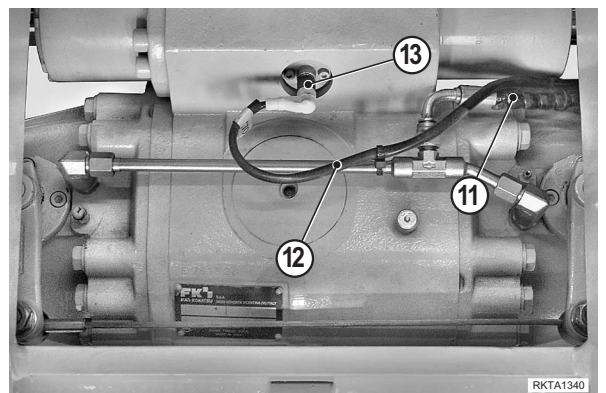

- 10 - Introduce a pin (E) into the equipment attachment hole.
- 11 - Place and a hydraulic jack (F) of min. 5 ton capacity firmly in place under the pin (E).

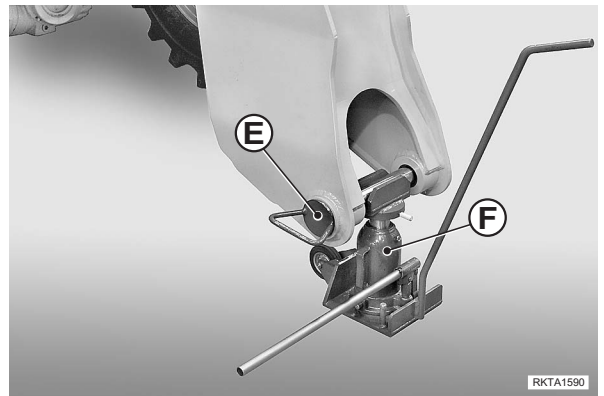

- 12 - Remove the boom lift ropes or chains, and then connect to the hoist a standard chain fastened to the attachment (G) of the boom (9) on the fulcrum side. Put under slight tension.

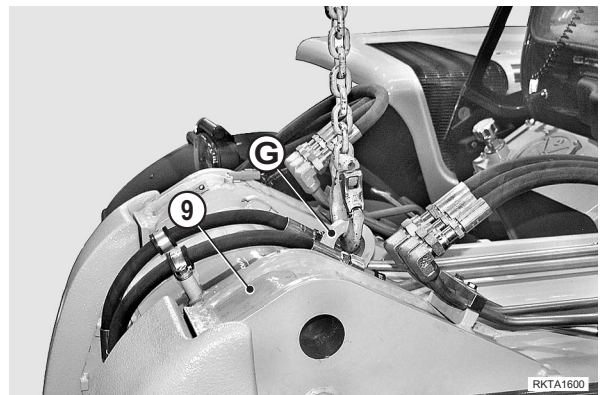

- 13 - Slightly lower the jack (F) and remove the block (D).
- 14 - As you work on the hydraulic jack (F) with the hoist, swing the boom (9) and locate the fulcrum pin hole centering position.

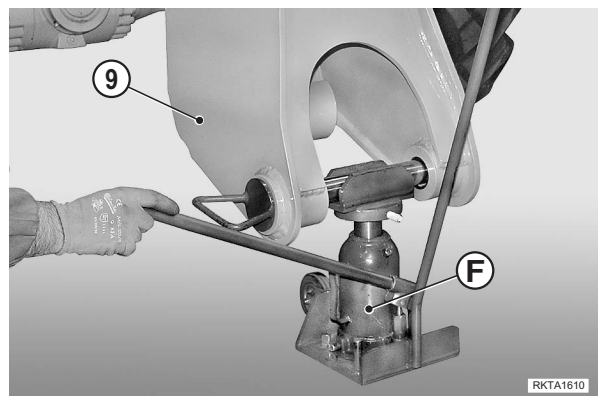

- 15 - Introduce a shim (16) to the right between the frame (17) and the boom (9); introduce the pin (14) and then introduce the remaining shims on the left side.

- ★ The quantity of shims used should be enough to leave less than 1 mm clearance between the boom and the frame.
- ★ If more than two shims are needed, you should install the larger amount of shims to the left side.

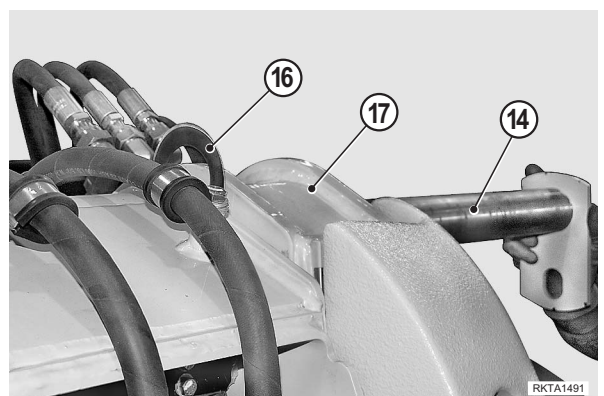

- 5 -Partially remove the cylinder (5).
Connect the cylinder to a hoist and then remove it completely.

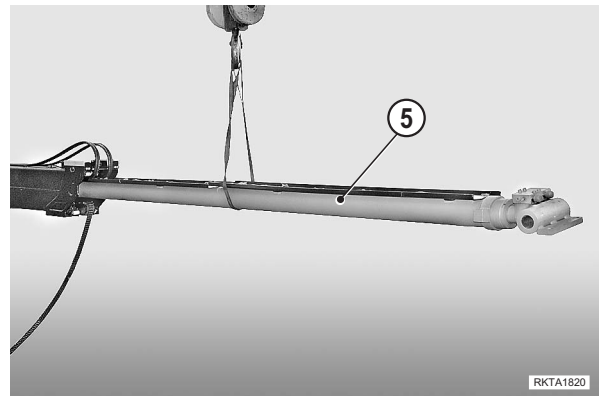

Installation

- To install, reverse the removal procedure.

[*1]

 Screws: 580 ± 12 Nm

- 1 -Start the engine and perform full extension and retraction motions in order to bleed the air from the circuit.
- 2 -Stop the engine and check the hydraulic oil level.

EXTENSION AND RETRACTION CHAINS

(Versions with 3-section boom)

Removal

- 1 -Remove the intermediate boom complete with top boom.
(For details, see "INTERMEDIATE AND TOP BOOM" until point 19).
- 2 -Loosen the nuts (1) and disconnect the rods and guide blocks (2). [*1]

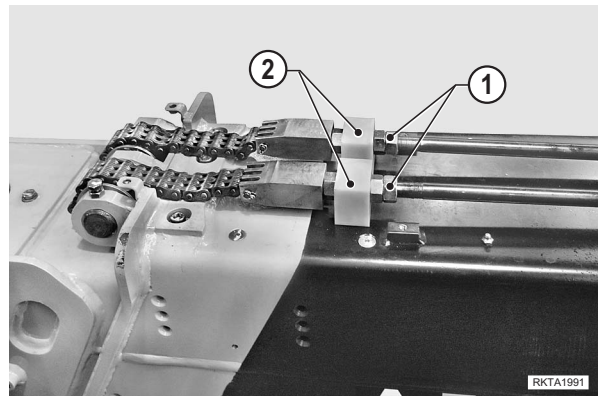

- 3 -Remove the screws (3) and remove the idler wheel assembly (4) guiding the extension chain.

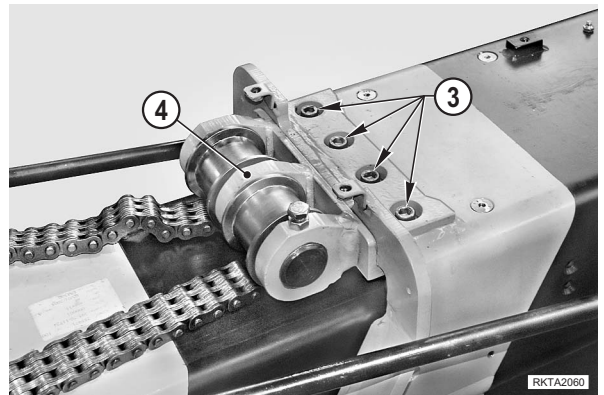

- 4 -Loosen and remove the screws; remove the check plates (5) along with the top boom side guide sliding pads (6) and their respective shims.

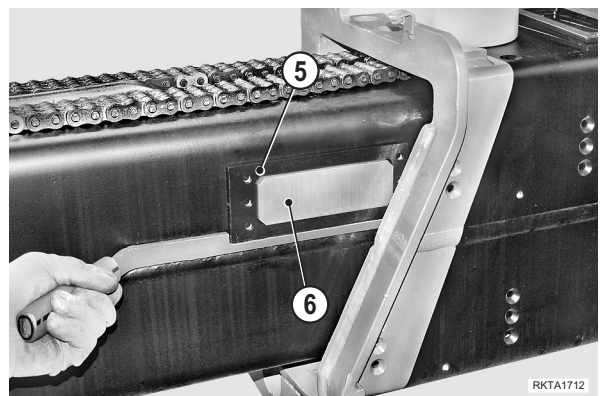

- 5 -Loosen and remove the screws; remove the top boom vertical guide sliding pads (7) and their respective shims.

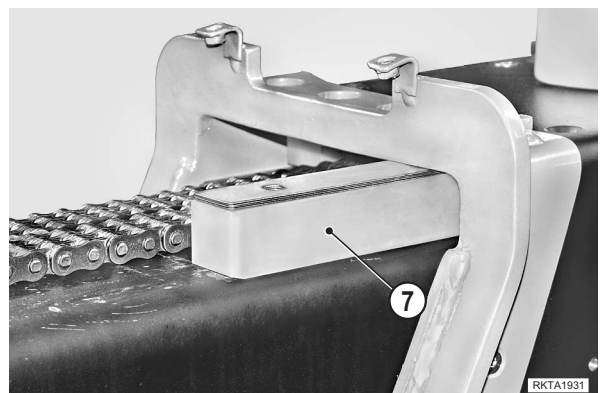

CONTROL UNIT

Removal

- 1 -Loosen and remove the four (1) screws and detach the device (2). [^{*}1]



- 2 -Disconnect the connector (3). [^{*}2]

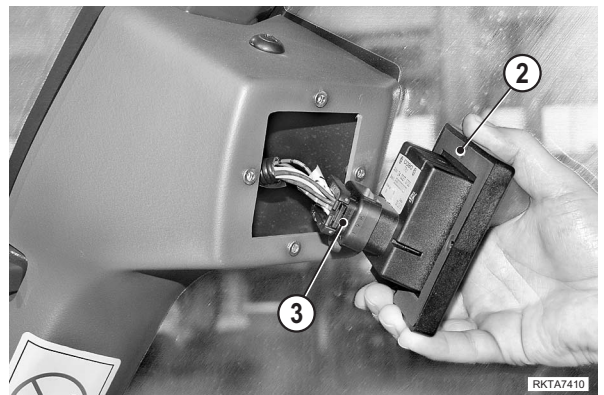

Installation

- To install, reverse the removal procedure.

[^{*}1]

- ★ Apply sealant to the notches provided for the screwdriver.

 Sealant: Black silicone

[^{*}2]

- ★ Before operating the machine, carry out the device calibration procedure.
(For details, see "20 TESTING AND ADJUSTMENTS").

Disassembly

1 -Clamp the complete power steering body (1) in a vice with the screws facing upwards. Use a vice whose jaws are lined with tender material (aluminium or soft steel).

- ★ Do not tighten the vice excessively, or you will damage the power steering body.



2 -Mark the positions of the screws, cover (6) and metering assembly (8).

Loosen the screws (2), (3), (4), and (5) in a criss-cross manner and remove them.

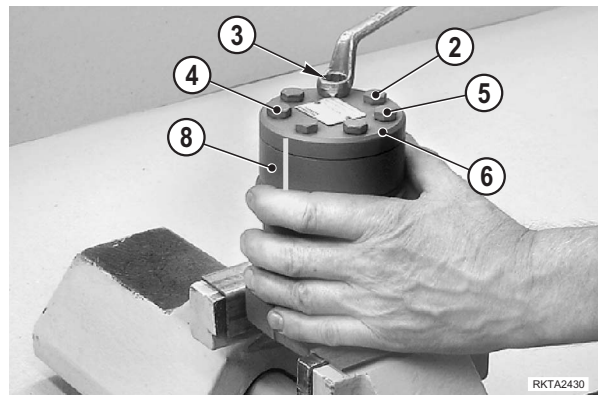

3 -Slide the cover (6) crosswise to remove it.



4 -Using needle nose pliers, remove the bushing (7).

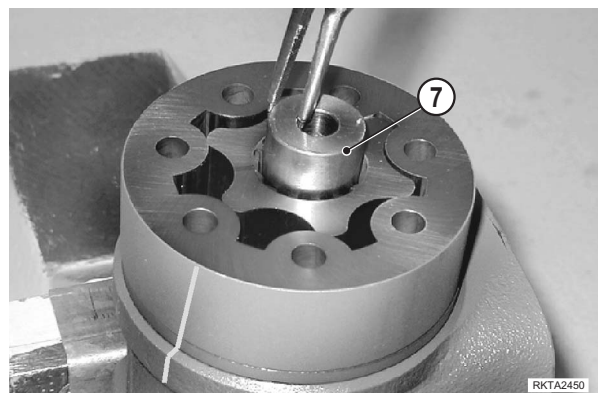

PPC VALVE

Removal

- 1 -Position the machine on level ground with the boom fully lowered and retracted.
- 2 -Stop the engine, remove the ignition key and apply the parking brakes.
- 3 -Raise the rubber boot (1) and remove the screws (2) retaining the PPC valve (3).

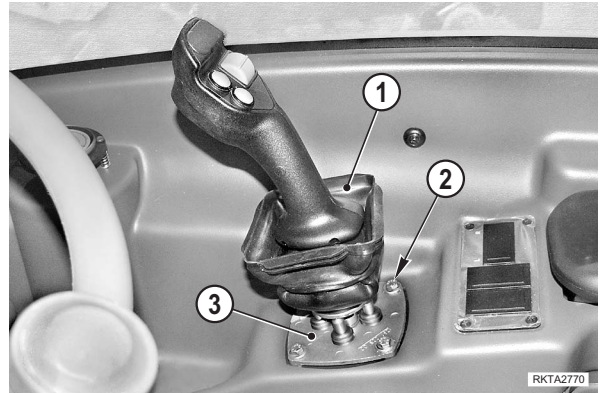

- 4 -Remove the screws and remove the fuse centre cover (4).



- 5 -Disconnect the connector (5) supplying the extension potentiometer, the auxiliaries pushbuttons and transmission release.

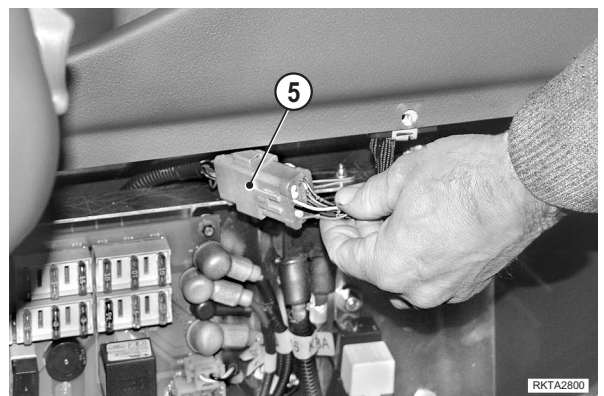

- 6 -Loosen and remove the screws (6) securing the feedthrough plate (7).

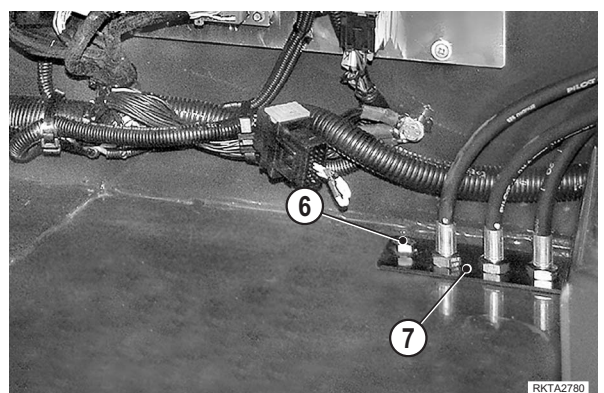

FUSE AND RELAY CENTRE

Removal

- 1 -Position the machine on firm, level ground.
- 2 -Apply the parking brakes and remove the ignition key.
- 3 -Disconnect the cable from the negative (-) battery terminal.



- 4 -Loosen the screws and remove the panel (1).



- 5 -Disconnect all wiring harnesses (2), ensuring that they are all marked.
- 6 -Loosen and remove the four self-locking nuts (4) and remove the complete circuit board.

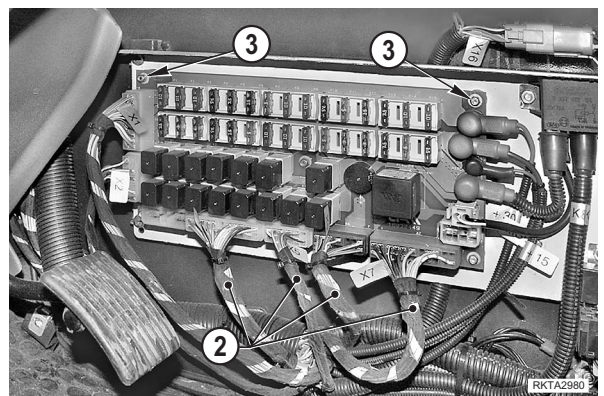

Installation

- To install, reverse the removal procedure.

STABILIZER CYLINDERS (If equipped)

Removal

- 1 -Position the machine on firm, level ground with the boom fully lowered and retracted.
- 2 -Lower the outriggers to the ground without forcing and place wedges under the rear wheels.
- 3 -Stop the engine, apply the parking brakes and remove the ignition key.

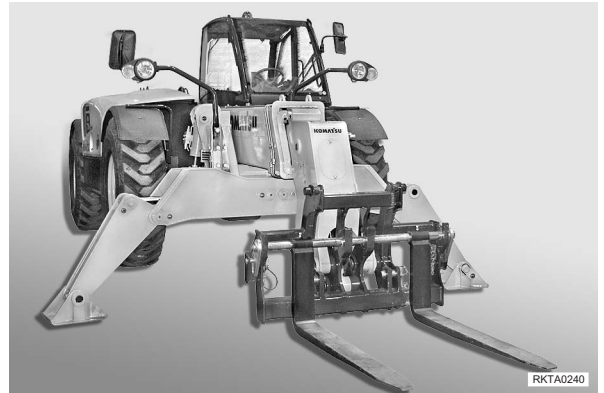

- 4 -Remove the upper cover (1) giving access to the safety valve.

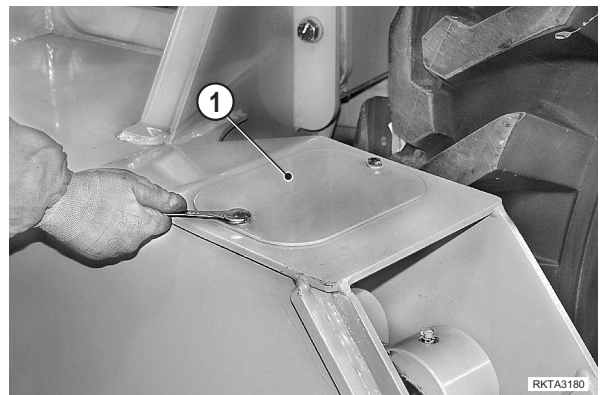

- 5 -Disconnect the lines (3), (4) from the valve (2).
 - ★ Cap the hoses and plug the holes to prevent contaminants from entering the passages.

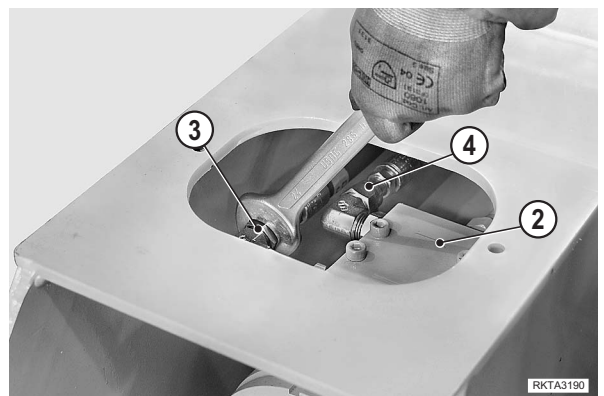

- 6 -Place a support roller (A) under the cylinder (5).

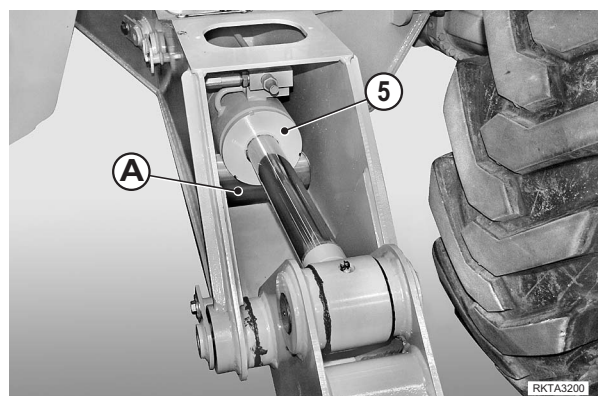

13 -Tighten the piston to the rod.

-  Lift piston:
 WH609: 1000±200 Nm
 WH613: 950–1000 Nm
 WH7: 1100±220 Nm
 Offset piston: 385±75 Nm
 Extension piston: 900±180 Nm
 Equipment control piston: 1000±200 Nm
 Outrigger piston: 900±180 Nm
 Levelling piston: 700±140 Nm
 Axle locking piston: 700±140 Nm

14 -Apply a coat of sealant to the retaining screw threads (7) and install the screw to the piston (8).

 Screw: Loctite 243

 Screw: 20 Nm

15 -Caulk the edge of the screw to prevent screw rotation.



16 -Check the cylinder, piston (6) and cylinder head (5) for being thoroughly clean.

17 -Lubricate cylinder head and piston seals.

 Seals: hydraulic oil

18 -With the cylinder in its horizontal position, introduce the piston (6) and the cylinder head (5).

- ★ Keep cylinder and piston perfectly aligned.
- ★ Be extremely careful not to damage the seals.

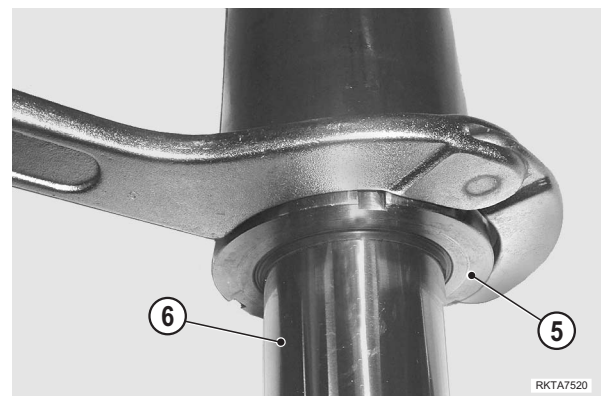

19 -Using a spanner, tighten and lock the cylinder head (5).

-  Lift piston: 450–500 Nm
 Offset piston: 250–300 Nm
 Extension piston: 450–500 Nm
 Equipment control piston: 450–500 Nm
 Outrigger piston: 450–500 Nm
 Levelling piston: 450–500 Nm
 Axle locking piston: 450 -500 Nm

9 -Mark and disconnect the service brake feed hoses (5), (6) from the brake pump. [*1]

10 -Disconnect the brake booster feed and discharge hoses (7), (8) from the brake pump.

- ★ Immediately cap the hoses and plug the holes to prevent contaminants from entering the passages.

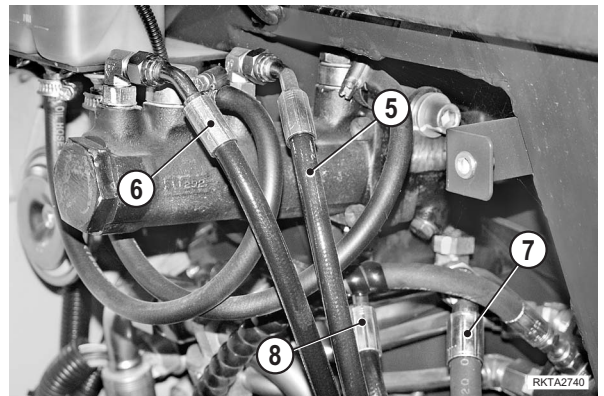

11 -Disconnect the hoses (9), (10).

12 -Disconnect the Load Sensing hose (11) from the steering unit.

- ★ Immediately cap the hoses and plug the holes to prevent contaminants from entering the passages.

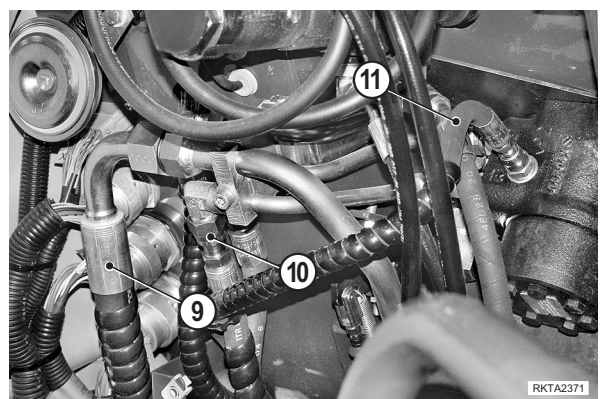

13 -Mark and disconnect the rear hoses (12), (13).

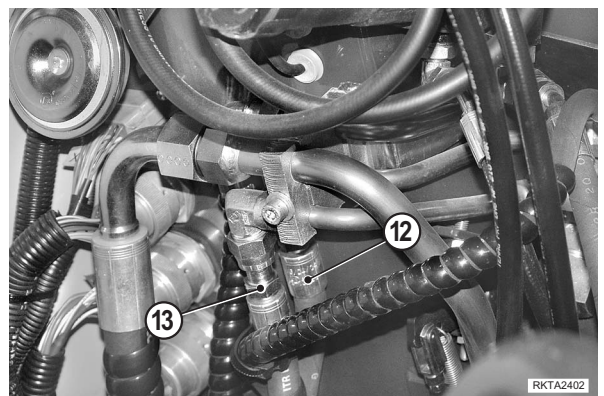

14 -Disconnect the washer fluid hoses (15) from the check valves (14).

- ★ Disconnect the hoses at the check valve output.

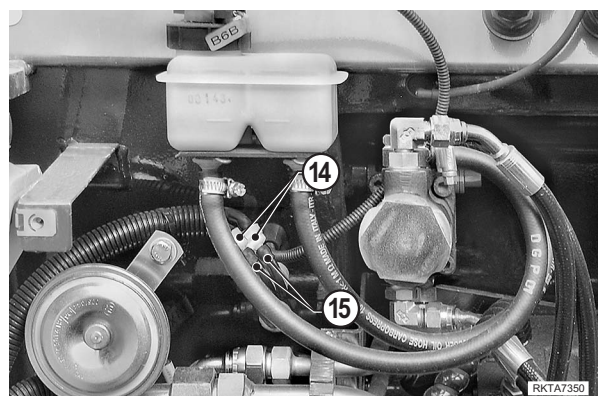

21 -Remove the forward and reverse clutch assembly (27).

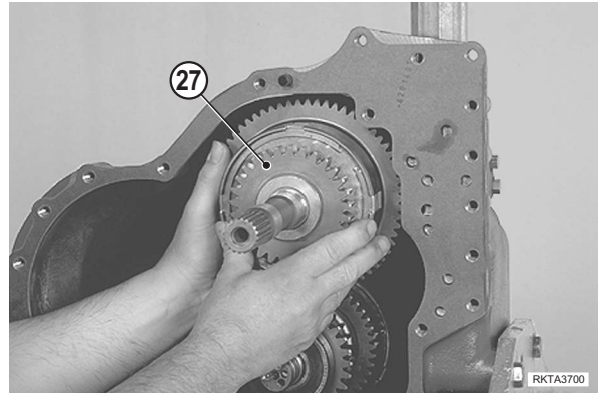

22 -Remove the 3rd and 4th clutch assembly (28).

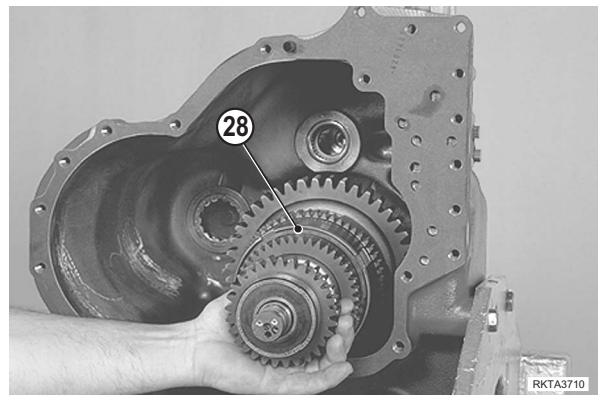

23 -Remove clutch assembly rear bearings (29) and (30).

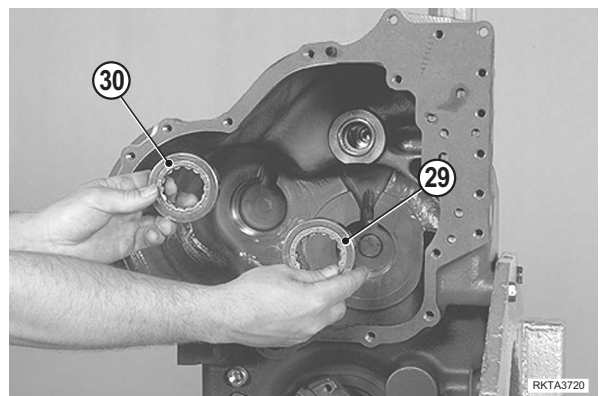

24 -Remove the modulator valve housings (31).

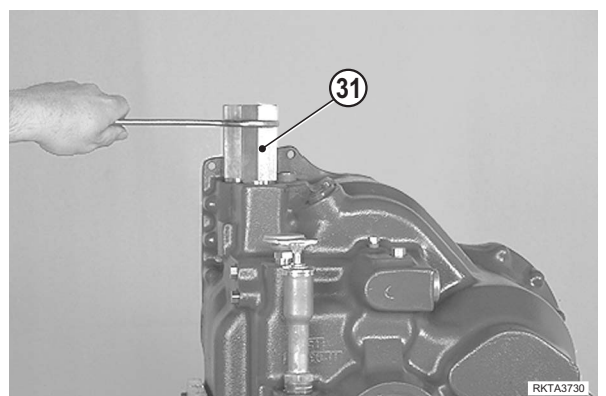

2nd CLUTCH

Disassembly

1 -Remove the shaft bearing outer race (1).

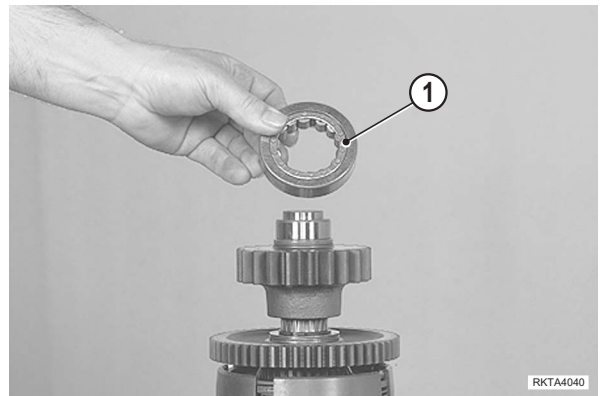

2 -Using a gear puller, remove the gear (2) and bearing inner race (1).

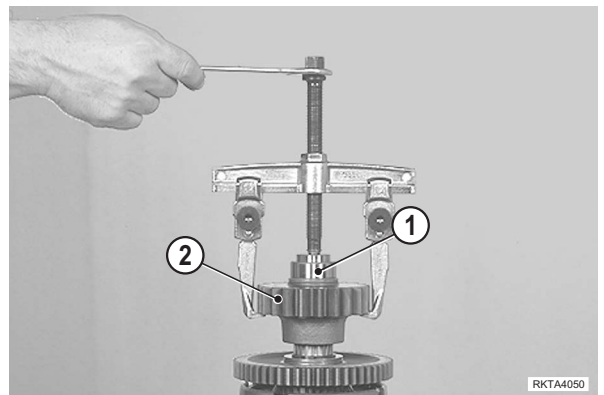

3 -Remove the ring (3) stopping the gear (2).

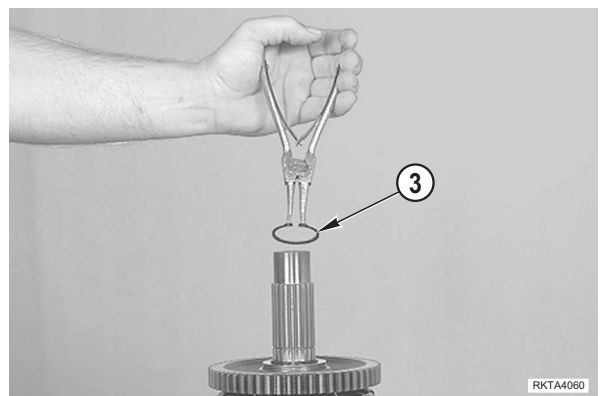

4 -Remove the ring (4) retaining the thrust bearing (5).

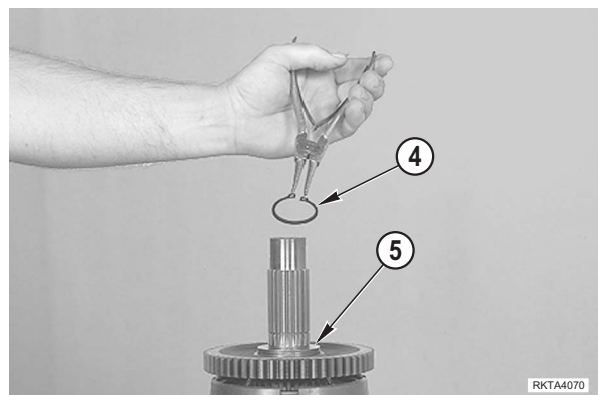

5 -Remove the thrust bearing (6).

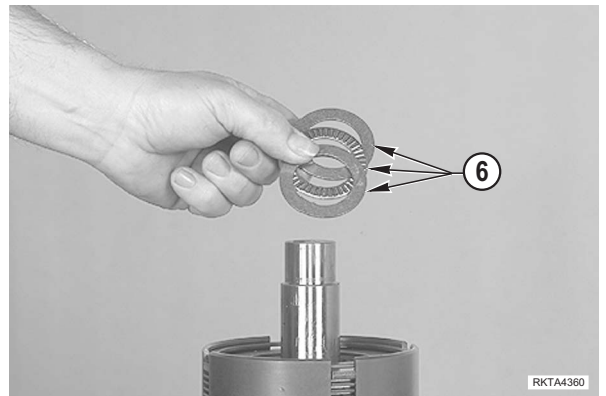

6 -Remove the clutch disc inner retainer ring (7).

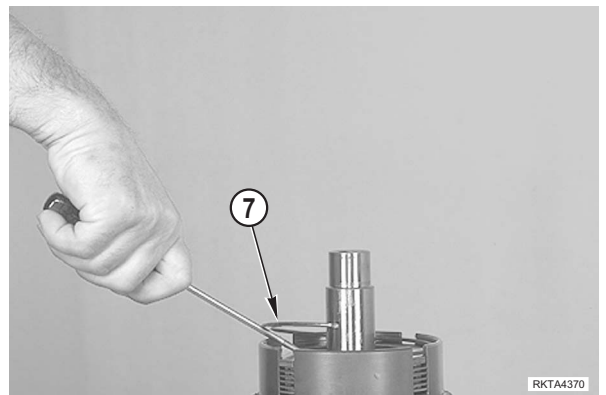

7 -Remove the end plate (8).

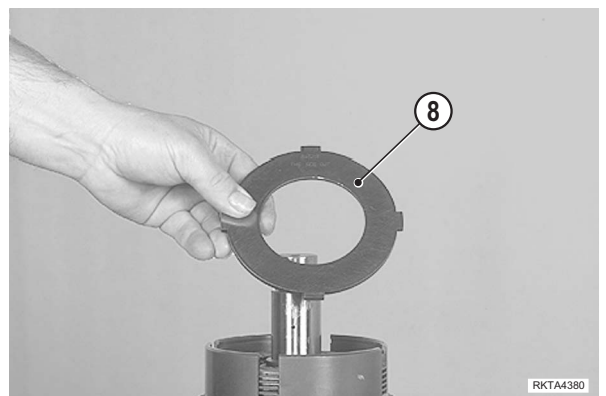

8 -Remove the clutch discs (9) and (10).

[*1]

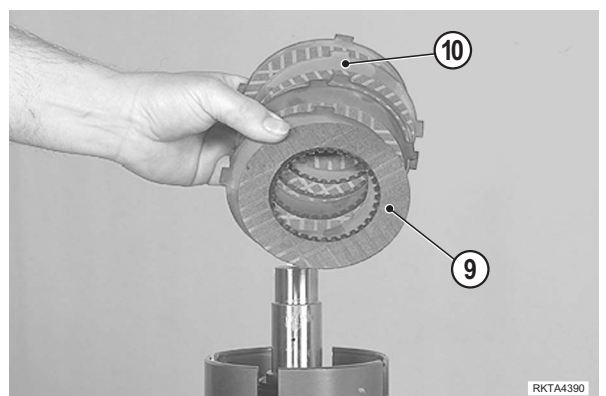

Assembly

- To assemble, reverse the disassembly procedure.

[*1]

- ★ Start clutch disc installation by placing a steel disc first.
- ★ Install 6 +6 clutch discs in total.

[*2]

- ★ After installing the snap ring, turn the assembly over and check clearance between piston and steel ring for being between 1.22 and 2.74 mm.
If clearance is greater than 2.74 mm, remove the snap ring (7) and end plate (8) and add a steel disc.

[*3]

- ★ Orient the springs (13) as shown to the side.

[*4]

- ★ The inner retainer ring should be extended to reach the size of the shaft. This is done by rolling the seal lip on a refaced piece of round steel.

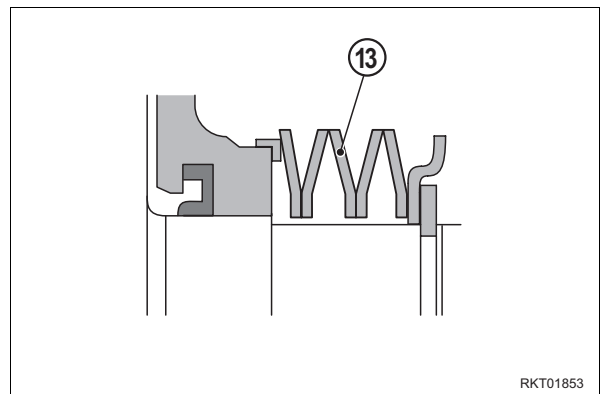

Assembly

- To assemble, reverse the disassembly procedure.

[*1]

- ★ Install the expander valve (17) and the segment (16) as shown to the side.

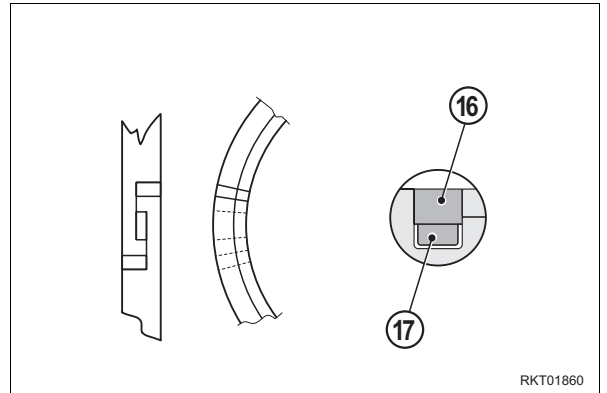

21 -Coat the outside of the seal ring (15) with sealant and install it to the flange (2).

 Seal ring: Loctite 641

22 -Install the O-ring (16) and the lubrication hole O-ring (17).

23 -Position the shim pack and flange.

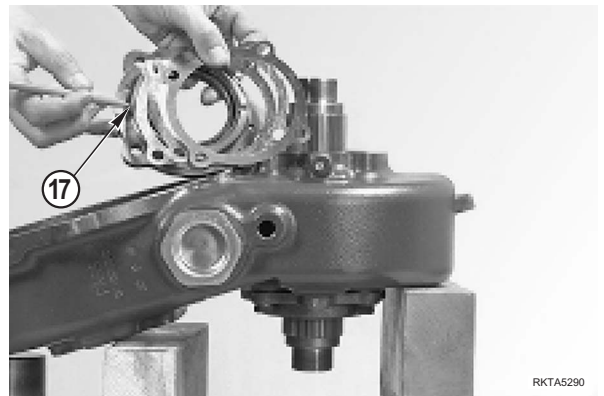

RKTA5290

24 -Install the screws (4) and washers and lock the flange.

 Screws: 40 -50 Nm

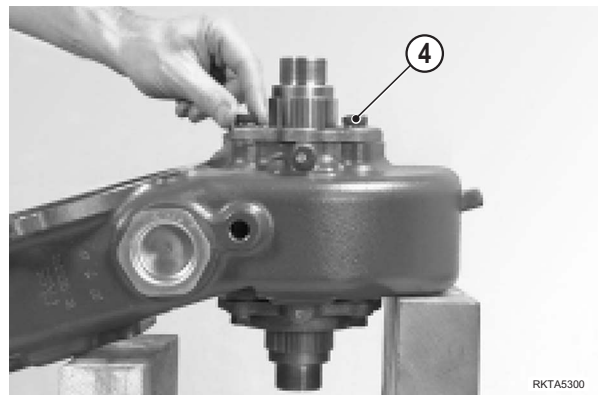

RKTA5300

25 -Coat the outside of the oil seal (18) with sealant and install it into the drop box body (19).

 Seal ring: Loctite 641

 Push the oil seal far enough to obtain the “M” size specified below:

★ “M” size: 4 mm

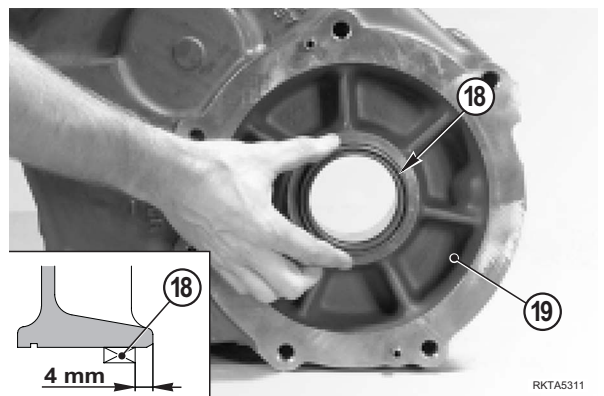

RKTA5311

26 -Position the drive gear (11) into the transmission case (20).

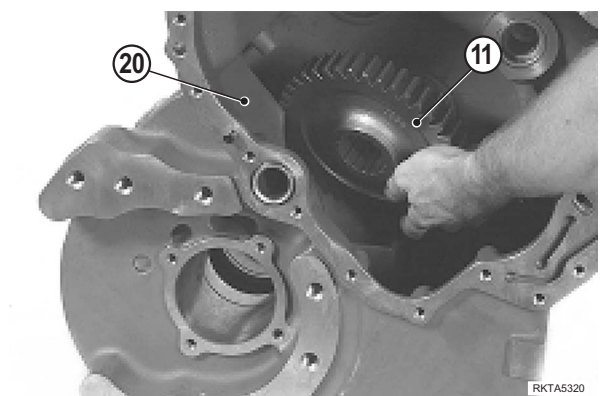

RKTA5320

3 -Unloose and remove the fitting screws (3) from the bottom articulation pin (4).

★ Screws cannot be re-used.

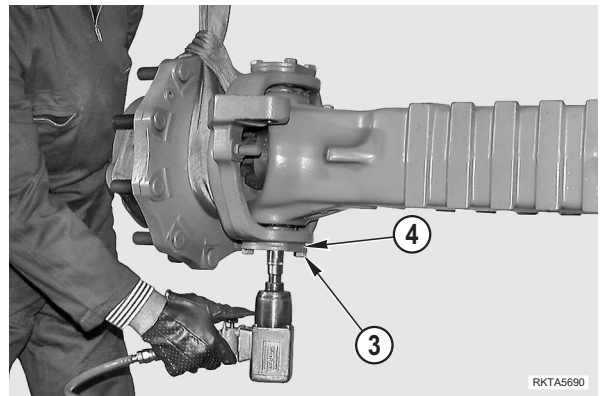

4 -Remove the bottom articulation pin (4) complete with front sealing ring (5).

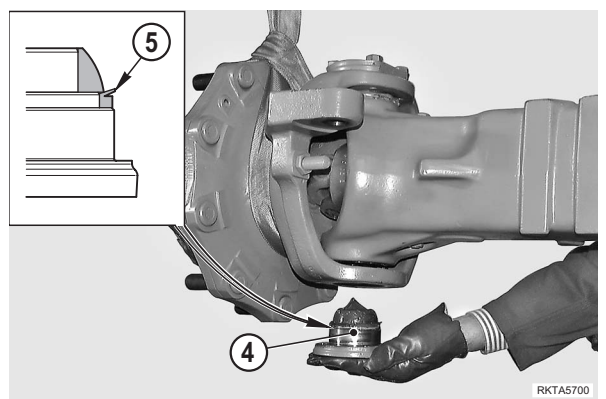

5 -Unloose and remove the fitting screws (3) from the top articulation pin (6).

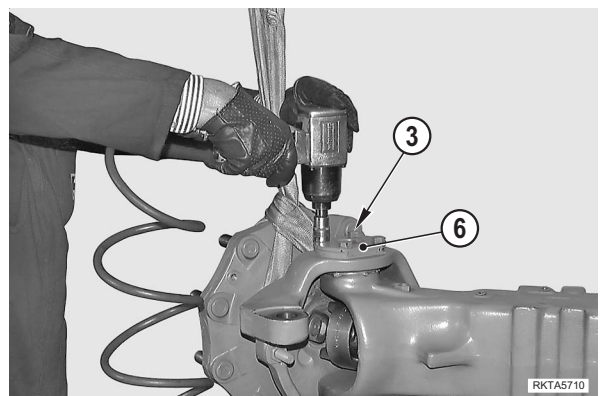

6 -Using two levers, remove the top articulation pin (6) complete with front seal (5). Pay attention not to damage the surfaces.

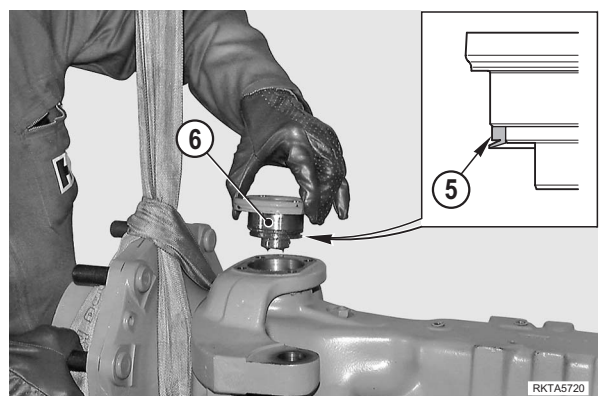

- **Disassembly of steering cylinder**

1 -Remove the snap ring (1) from the cylinder head (2).

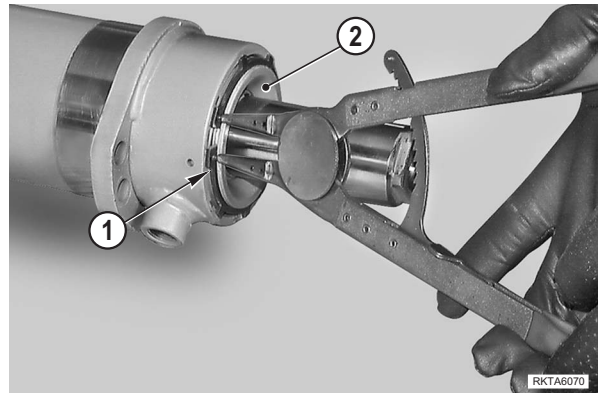

2 -With the help of a plastic hammer, push the head (2) inside the cylinder (3).

- ★ The head should line up with the edge of the cylinder.

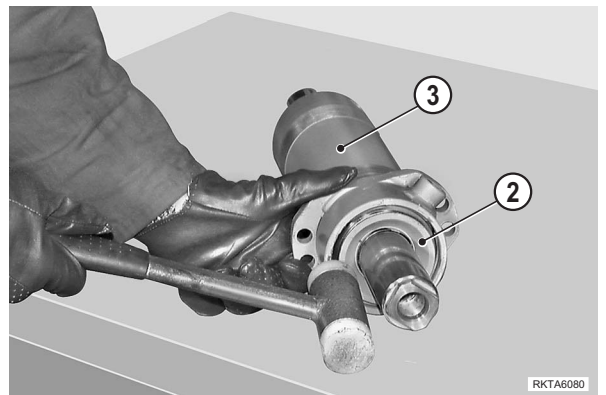

3 -With the help of a drift, apply pressure to the stop ring (4) that is placed inside the cylinder (3) and extract the ring using a screwdriver.

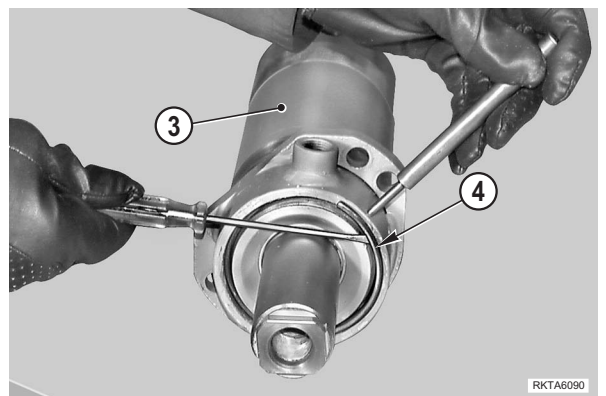

4 -Hammer the piston (5) on the rear of the head (2) using a plastic hammer. Continue hammering until the head (2) is ejected from the cylinder (3).



- 3 -Partially insert the thrust block of the external bearing (15).

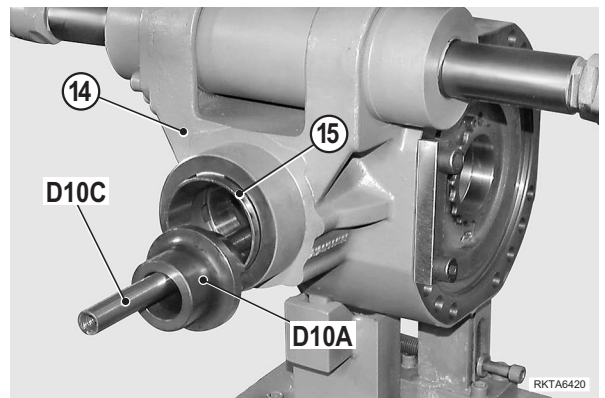

- 4 -Install tension rod **D10C**, measurement ring **D9** and front guide tool **D10A** on the thrust block of the external bearing (15).

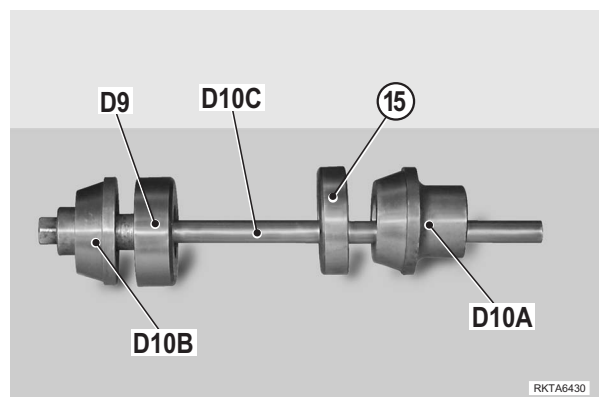

- 5 -Connect the tension rod to the press and move the thrust block of the external bearing (15) into its seat. Disconnect the press and remove the tension rod.

! Before starting the next stage, make sure that the thrust block has been completely inserted into its seat.

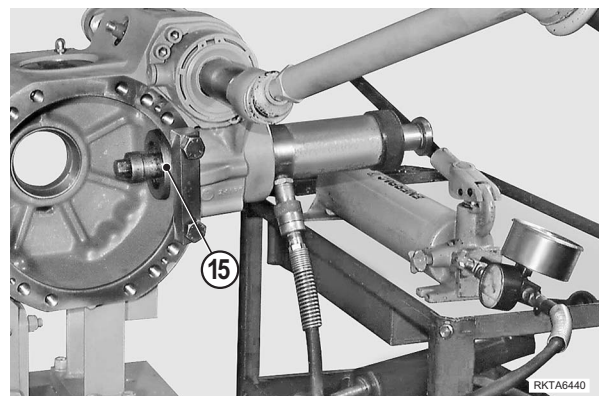

- 6 -Insert tool **D11B** complete with external bearing (15), measurement ring **D9** and gauged ring nut **D11C**. Manually tighten.

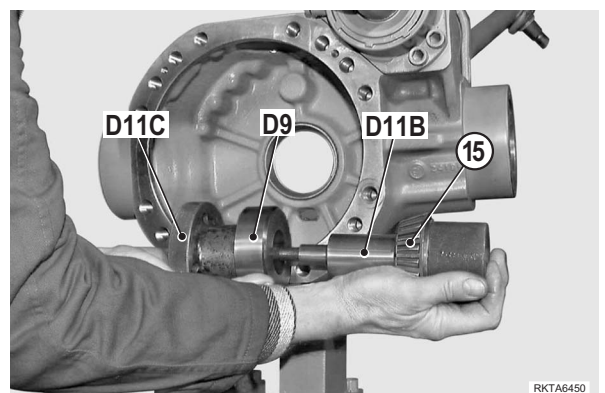

13 -Position the crown (12) on the differential carrier (15) and lock it with screws (11) applied with Loctite 242.

 Torque wrench setting for screw: 128 -142 Nm

★ Secure the screws using the cross-tightening method.

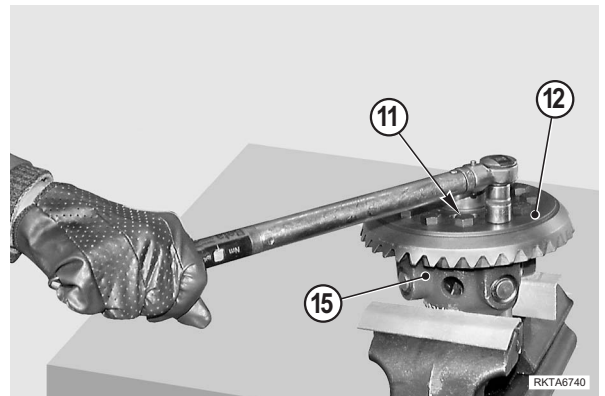

14 -Install the bearings (7) and (8) using tool D15.

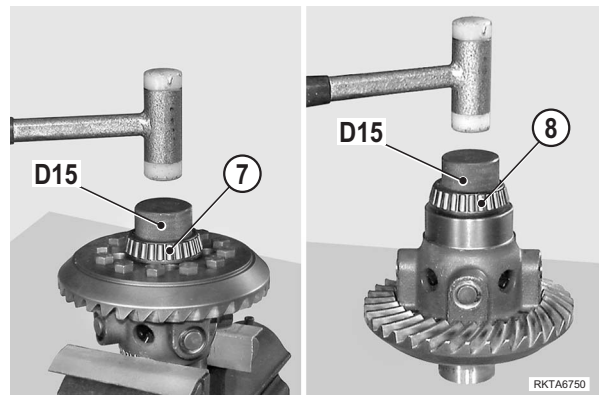

15 -If the bearings are replaced, insert the external thrust blocks in the middle cover (5) and in the central body (2).

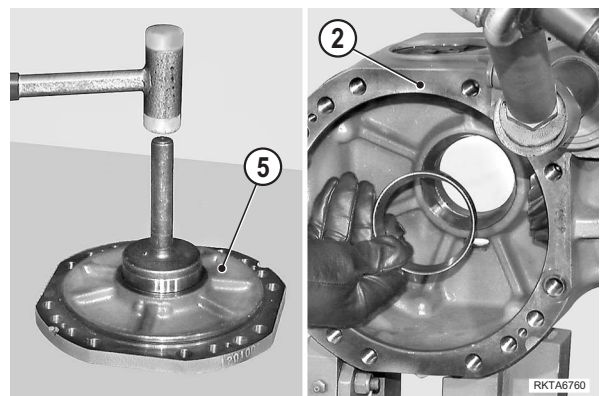

16 -Position the differential unit (6) in the central body (2) with the help of a bar and fit the middle cover (5).

★ Thoroughly check the state of the O-ring (9) and make sure that the cover is fitted with the oil discharge in the lower position.

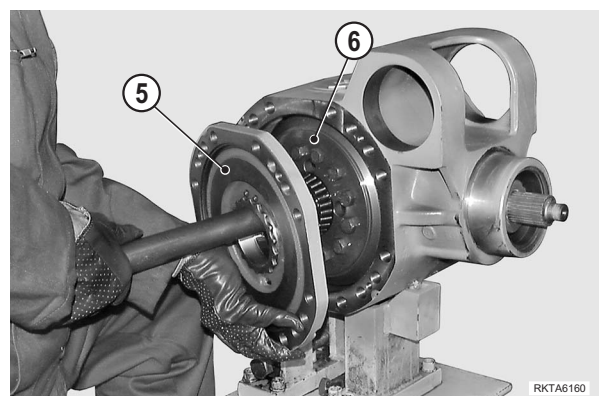

- 3 -Re-install piston (10) and brake rotors (9).
(For details, see "Brakes").

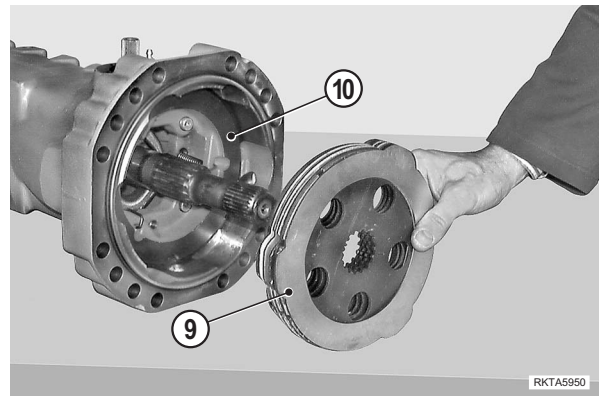

- 4 -Install the axle shafts (8) to the main body; check for proper axle shaft levelling and then lock the axle shafts.
(For details, see "Brakes").

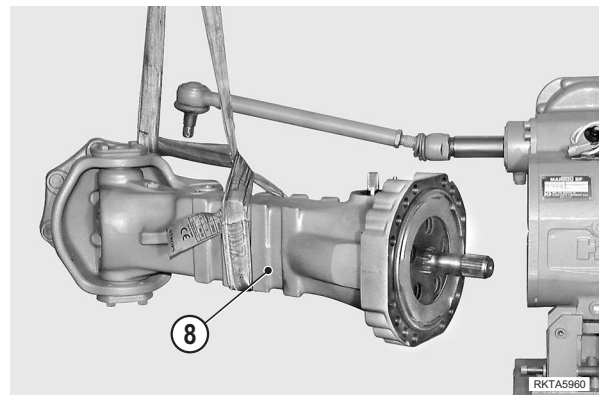

- 5 -Install the bushing (6) together with the O-ring seal (7) and lock it into position with screws (5).

 Torque wrench setting for screw: 23.8 -26.2 Nm

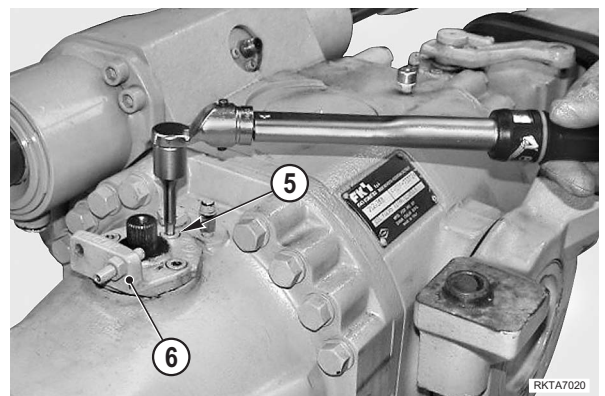

- 6 -Install the following parts in the sequence given: lower O-ring seal (4), lever (3) washer (2) and associated O-ring seal (4), and then lock into position with a screw (1).

★ Do not change the positions previously marked during disassembly.

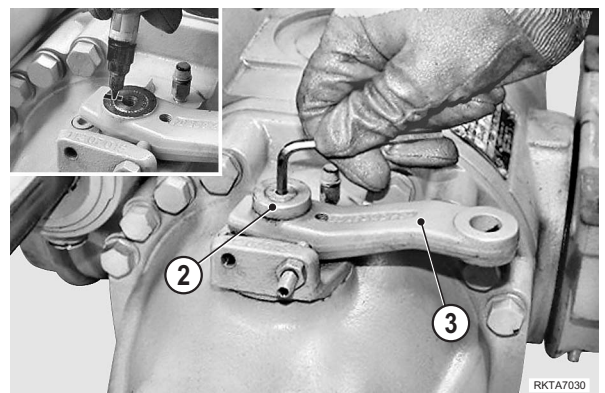

CLICK HERE TO **DOWNLOAD** THE COMPLETE MANUAL

- Thank you very much for reading the preview of the manual.
- You can download the complete manual from: www.heydownloads.com by clicking the link below



- Please note: If there is no response to CLICKING the link, please download this PDF first and then click on it.

CLICK HERE TO **DOWNLOAD** THE COMPLETE MANUAL