

# Shop Manual

WHEEL LOADER

**WA380-7**

SERIAL NUMBERS 10001 and up

**KOMATSU**

CLICK HERE TO **DOWNLOAD** THE COMPLETE MANUAL

- Thank you very much for reading the preview of the manual.
- You can download the complete manual from: [www.heydownloads.com](http://www.heydownloads.com) by clicking the link below



- Please note: If there is no response to CLICKING the link, please download this PDF first and then click on it.

CLICK HERE TO **DOWNLOAD** THE COMPLETE MANUAL

## 00 Index and foreword

### Foreword, safety and general information

---

- When tightening nuts of the air conditioner hoses and tubes, be sure to use 2 wrenches. Use one wrench to fix and tighten the nut with the other wrench to the specified torque (Use a torque wrench for tightening).
- ★ Example of fitting of O-ring
  - An O-ring is fitted to every joint of the air conditioner piping.

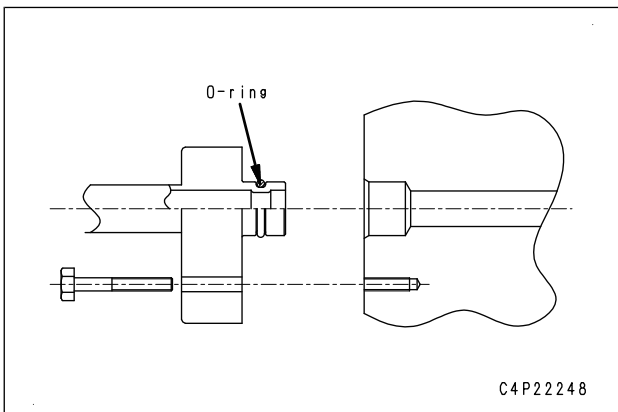
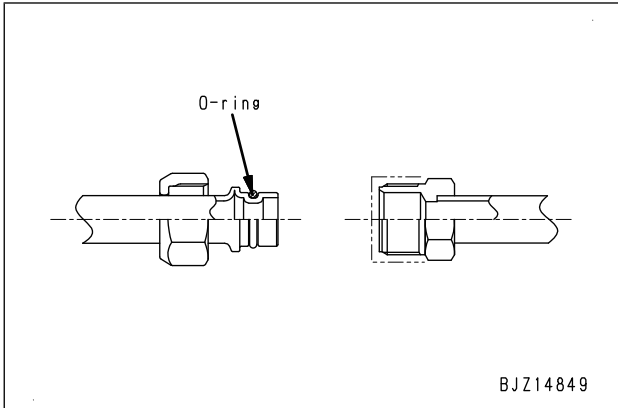

**For tightening torques, see "Others",  
"Precautions for disconnection and connection  
of air conditioner piping".**

**Dimensions**  
(Table 2)

Nominal No.		0.5f	(0.5)	0.75f	(0.85)	1.25f	(1.25)	2f	2	3f	3	5
Conductor	Number of strands/ Diameter of strand	20/ 0.18	7/0.32	30/ 0.18	11/ 0.32	50/ 0.18	16/ 0.32	37/ 0.26	26/ 0.32	58/ 0.26	41/ 0.32	65/ 0.32
	Cross-sectional area (mm <sup>2</sup> )	0.51	0.56	0.76	0.88	1.27	1.29	1.96	2.09	3.08	3.30	5.23
	d (approx.)	1.0		1.2		1.5		1.9	1.9	2.3	2.4	3.0
Coating D	AVS	Standard	2.0	2.2		2.5		2.9	2.9	3.5	3.6	—
	AV	Standard	—	—		—		—	—	—	—	4.6
	AEX	Standard	2.0	2.2		2.7		3.0	3.1	—	3.8	4.6
Nominal No.		8	15	20	30	40	50	60	85	100		
Conductor	Number of strands/ Diameter of strand	50/0.45	84/0.45	41/0.80	70/0.80	85/0.80	108/ 0.80	127/ 0.80	169/ 0.80	217/ 0.80		
	Cross-sectional area (mm <sup>2</sup> )	7.95	13.36	20.61	35.19	42.73	54.29	63.84	84.96	109.1		
	d (approx.)	3.7	4.8	6.0	8.0	8.6	9.8	10.4	12.0	13.6		
Coating D	AVS	Standard	—	—	—	—	—	—	—	—	—	—
	AV	Standard	5.5	7.0	8.2	10.8	11.4	13.0	13.6	16.0	17.6	
	AEX	Standard	5.3	7.0	8.2	10.8	11.4	13.0	13.6	16.0	17.6	
Nominal No.		0.5f	0.5		0.75f	0.85		1.25f	1.25			
Conductor	Number of strands/ Diameter of strand	—	7/round compression		—	11/round compression		—	16/round compression			
	Cross-sectional area (mm <sup>2</sup> )	—	0.56		—	0.88		—	1.29			
	d (approx.)	—	0.9		—	1.1		—	1.4			
Coating D	CAVS	Standard	—	1.6	—	1.8	—	2.1				

★ "f" of nominal No. denotes "flexible".

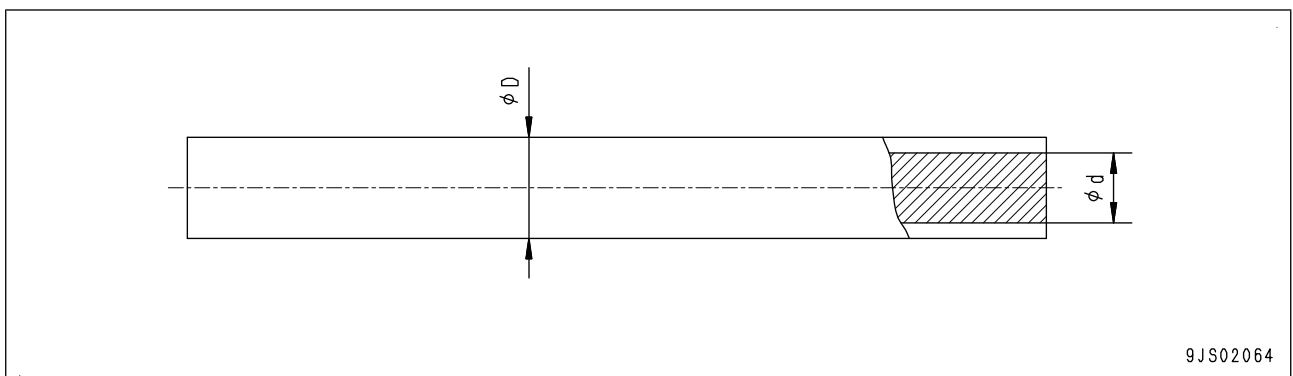

# 00 Index and foreword

## Foreword, safety and general information

### Temperature

#### Conversion of Fahrenheit to Celsius

- A simple way to convert a Fahrenheit temperature reading into a Celsius temperature reading or vice versa is to see the number in the center column of the following table. The figures on the following table show the temperatures in both Fahrenheit and Celsius.
- When converting from Fahrenheit to Celsius degrees, consider the center column to be a table of Fahrenheit temperatures and read the corresponding Celsius temperature in the column at the left.
- When converting from Celsius to Fahrenheit degrees, consider the center column to be a table of Celsius values, and read the corresponding Fahrenheit temperature on the right.

$$1^{\circ}\text{C} = 33.8^{\circ}\text{F}$$

°C		°F	°C		°F	°C		°F	°C		°F
-40.4	-40	-40.0	-11.7	11	51.8	7.8	46	114.8	27.2	81	177.8
-37.2	-35	-31.0	-11.1	12	53.6	8.3	47	116.6	27.8	82	179.6
-34.4	-30	-22.0	-10.6	13	55.4	8.9	48	118.4	28.3	83	181.4
-31.7	-25	-13.0	-10.0	14	57.2	9.4	49	120.2	28.9	84	183.2
-28.9	-20	-4.0	-9.4	15	59.0	10.0	50	122.0	29.4	85	185.0
-28.3	-19	-2.2	-8.9	16	60.8	10.6	51	123.8	30.0	86	186.8
-27.8	-18	-0.4	-8.3	17	62.6	11.1	52	125.6	30.6	87	188.6
-27.2	-17	1.4	-7.8	18	64.4	11.7	53	127.4	31.1	88	190.4
-26.7	-16	3.2	-7.2	19	66.2	12.2	54	129.2	31.7	89	192.2
-26.1	-15	5.0	-6.7	20	68.0	12.8	55	131.0	32.2	90	194.0
-25.6	-14	6.8	-6.1	21	69.8	13.3	56	132.8	32.8	91	195.8
-25.0	-13	8.6	-5.6	22	71.6	13.9	57	134.6	33.3	92	197.6
-24.4	-12	10.4	-5.0	23	73.4	14.4	58	136.4	33.9	93	199.4
-23.9	-11	12.2	-4.4	24	75.2	15.0	59	138.2	34.4	94	201.2
-23.3	-10	14.0	-3.9	25	77.0	15.6	60	140.0	35.0	95	203.0
-22.8	-9	15.8	-3.3	26	78.8	16.1	61	141.8	35.6	96	204.8
-22.2	-8	17.6	-2.8	27	80.6	16.7	62	143.6	36.1	97	206.6
-21.7	-7	19.4	-2.2	28	82.4	17.2	63	145.4	36.7	98	208.4
-21.1	-6	21.2	-1.7	29	84.2	17.8	64	147.2	37.2	99	210.2
-20.6	-5	23.0	-1.1	30	86.0	18.3	65	149.0	37.8	100	212.0
-20.0	-4	24.8	-0.6	31	87.8	18.9	66	150.8	40.6	105	221.0
-19.4	-3	26.6	0	32	89.6	19.4	67	152.6	43.3	110	230.0
-18.9	-2	28.4	0.6	33	91.4	20.0	68	154.4	46.1	115	239.0
-18.3	-1	30.2	1.1	34	93.2	20.6	69	156.2	48.9	120	248.0
-17.8	0	32.0	1.7	35	95.0	21.1	70	158.0	51.7	125	257.0
-17.2	1	33.8	2.2	36	96.8	21.7	71	159.8	54.4	130	266.0
-16.7	2	35.6	2.8	37	98.6	22.2	72	161.6	57.2	135	275.0
-16.1	3	37.4	3.3	38	100.4	22.8	73	163.4	60.0	140	284.0
-15.6	4	39.2	3.9	39	102.2	23.3	74	165.2	62.7	145	293.0
-15.0	5	41.0	4.4	40	104.0	23.9	75	167.0	65.6	150	302.0
-14.4	6	42.8	5.0	41	105.8	24.4	76	168.8	68.3	155	311.0
-13.9	7	44.6	5.6	42	107.6	25.0	77	170.6	71.1	160	320.0
-13.3	8	46.4	6.1	43	109.4	25.6	78	172.4	73.9	165	329.0
-12.8	9	48.2	6.7	44	111.2	26.1	79	174.2	76.7	170	338.0
-12.2	10	50.0	7.2	45	113.0	26.7	80	176.0	79.4	175	347.0

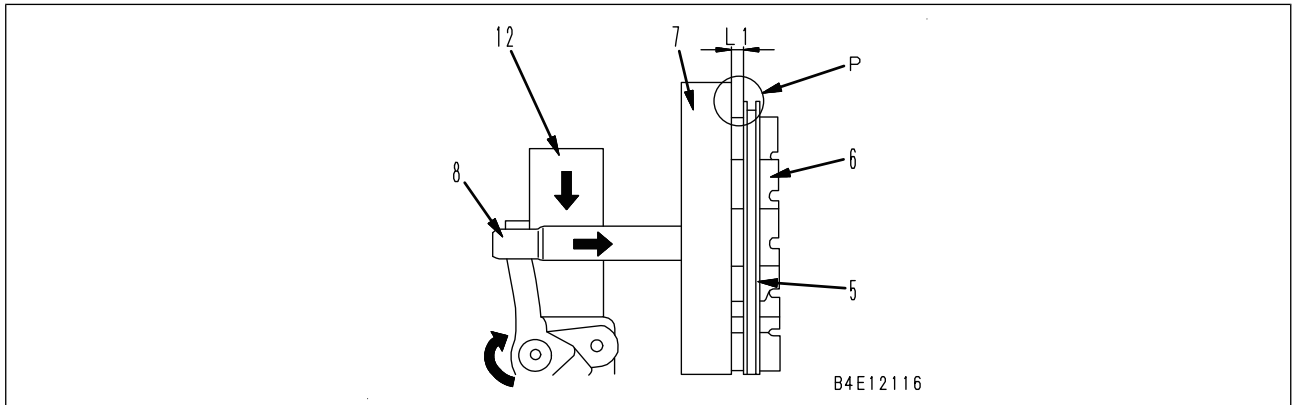

**When nozzle ring is open**

- At high engine speeds, exhaust gas inlet passage (P) is widened (L2).
- As the engine speed and the turbine inlet pressure (exhaust gas pressure) increases, exhaust gas inlet passage (P) widens (L2) to effectively apply the exhaust gas pressure to turbine impeller (11).

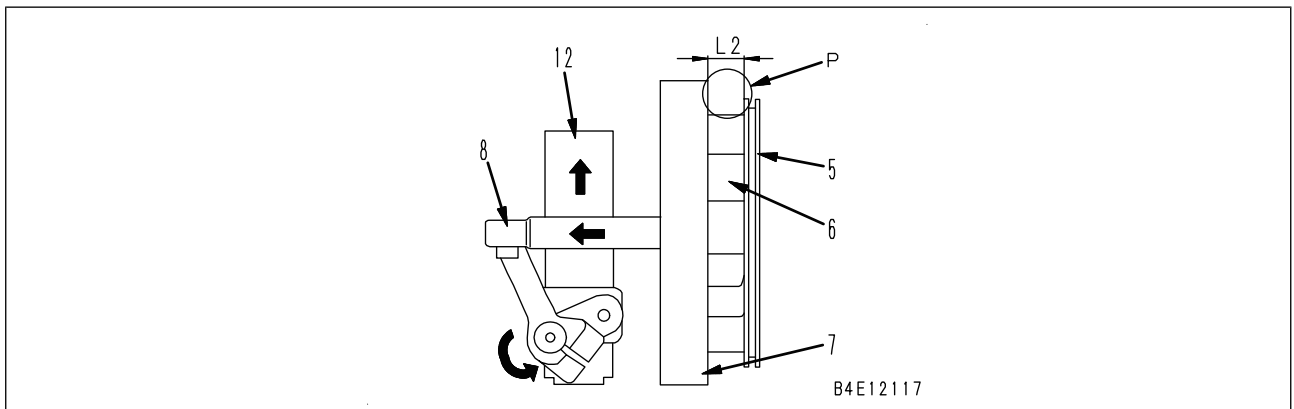

- ★ Nozzle ring (7), vane (6), and push rod (8) are integrated and slide together but do not rotate.
- ★ VGT position sensor is installed to hydraulic actuator (3). The VGT position sensor is calibrated together with the variable mechanism in the VGT, and values are stored in the memory inside the VGT position sensor. If any of the hydraulic actuator (3), VGT position sensor, or VGT body fails, replace the whole VGT.

# 10 Structure and function

## Cooling fan pump

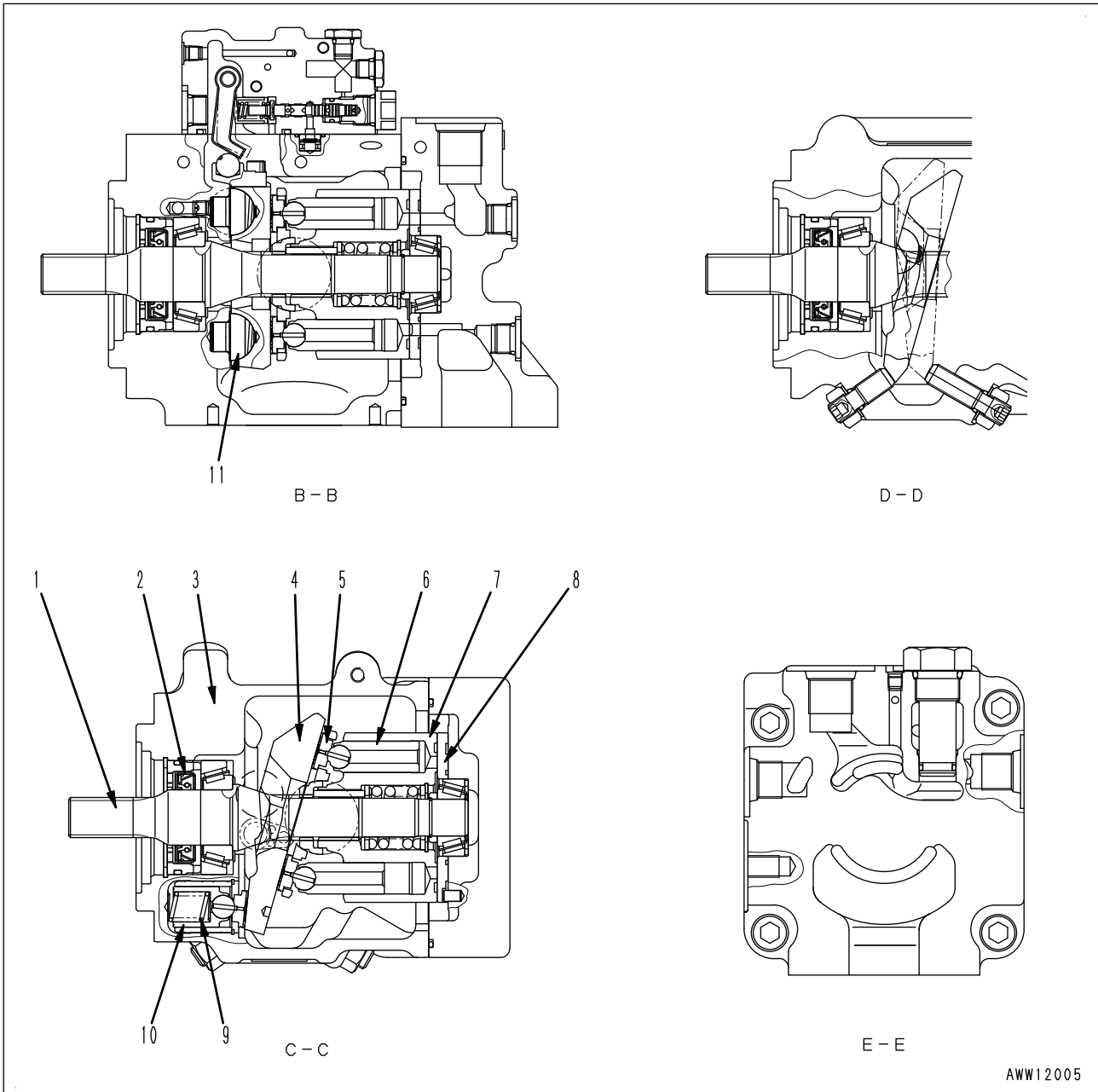

1. Shaft
2. Oil seal
3. Case
4. Rocker cam
5. Shoe
6. Piston
7. Cylinder block
8. Valve plate
9. Spring
10. Servo piston
11. Ball retainer

**Torque converter** (WA380-CD00-041-K-00-A)

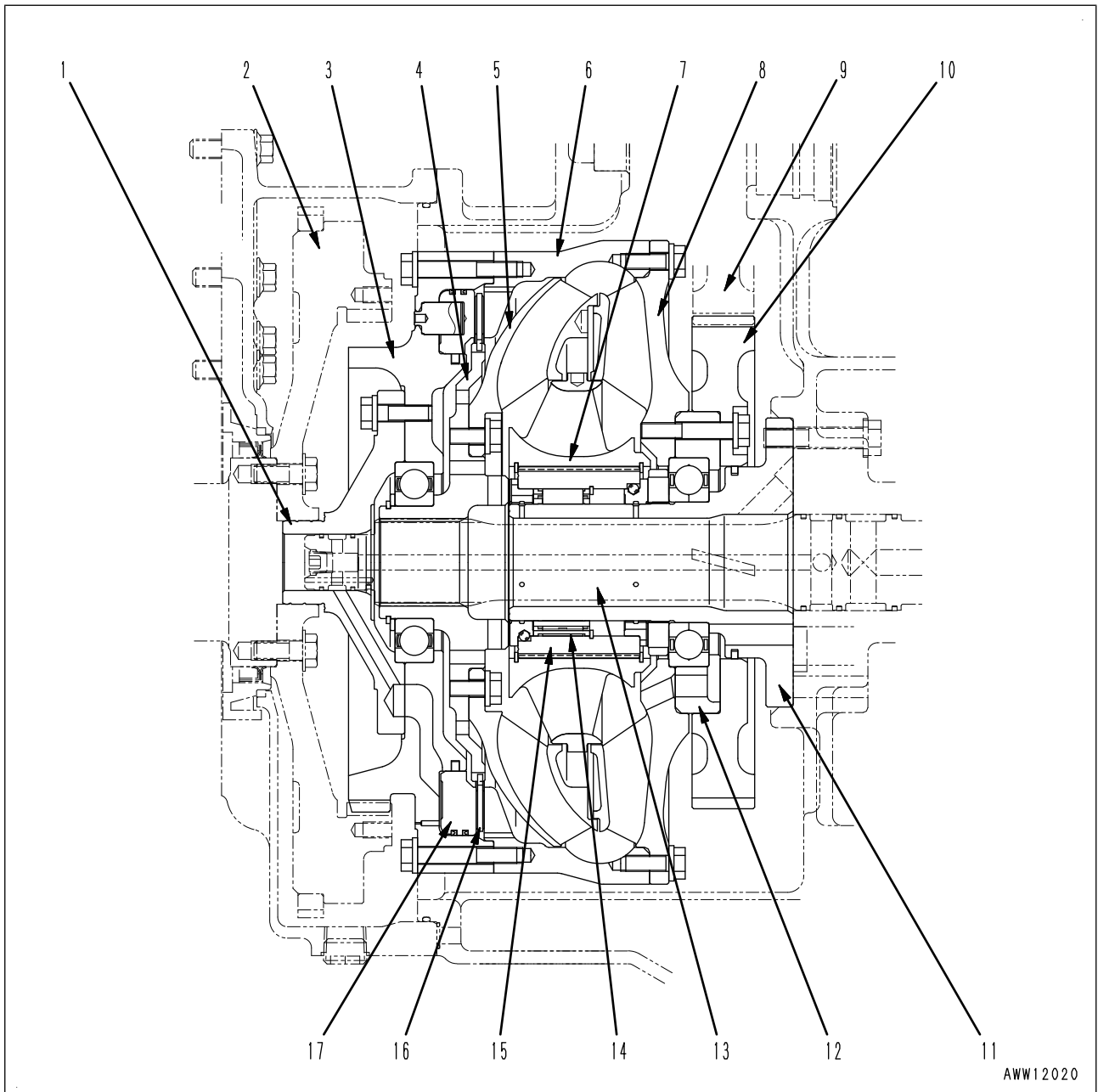

AWW12020

1. Pilot
2. Flywheel
3. Lockup clutch housing
4. Boss
5. Turbine
6. Drive case
7. Stator
8. Pump
9. PTO gear
10. PTO drive gear (number of teeth: 97)
11. Stator shaft
12. Guide
13. Input shaft

## 10 Structure and function

### Transmission

---

R clutch (4) and 1st clutch (10) are fixed hydraulically.

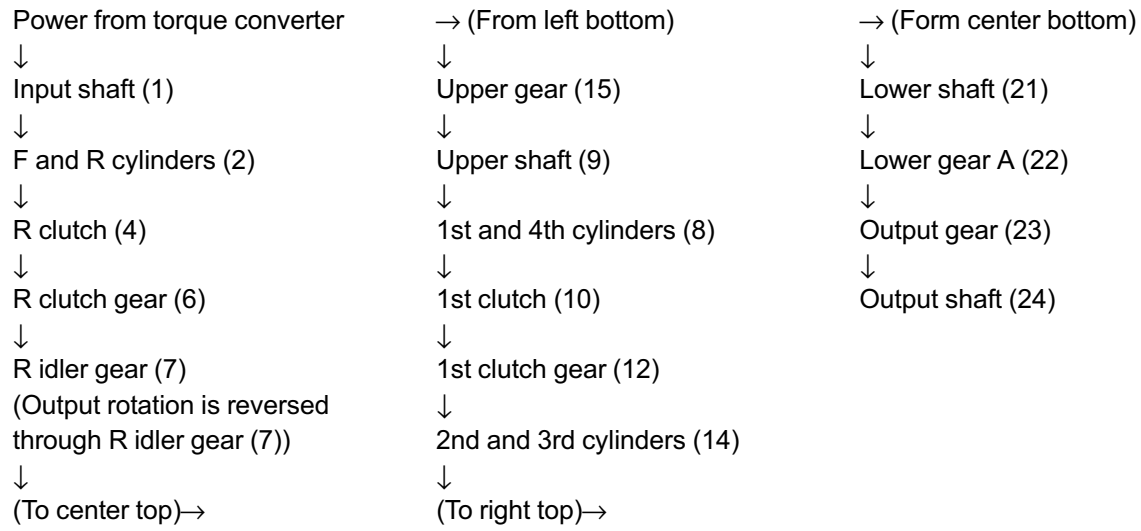

**Limited slip differential** (WA380-DCH2-041-K-00-A)

(if equipped)

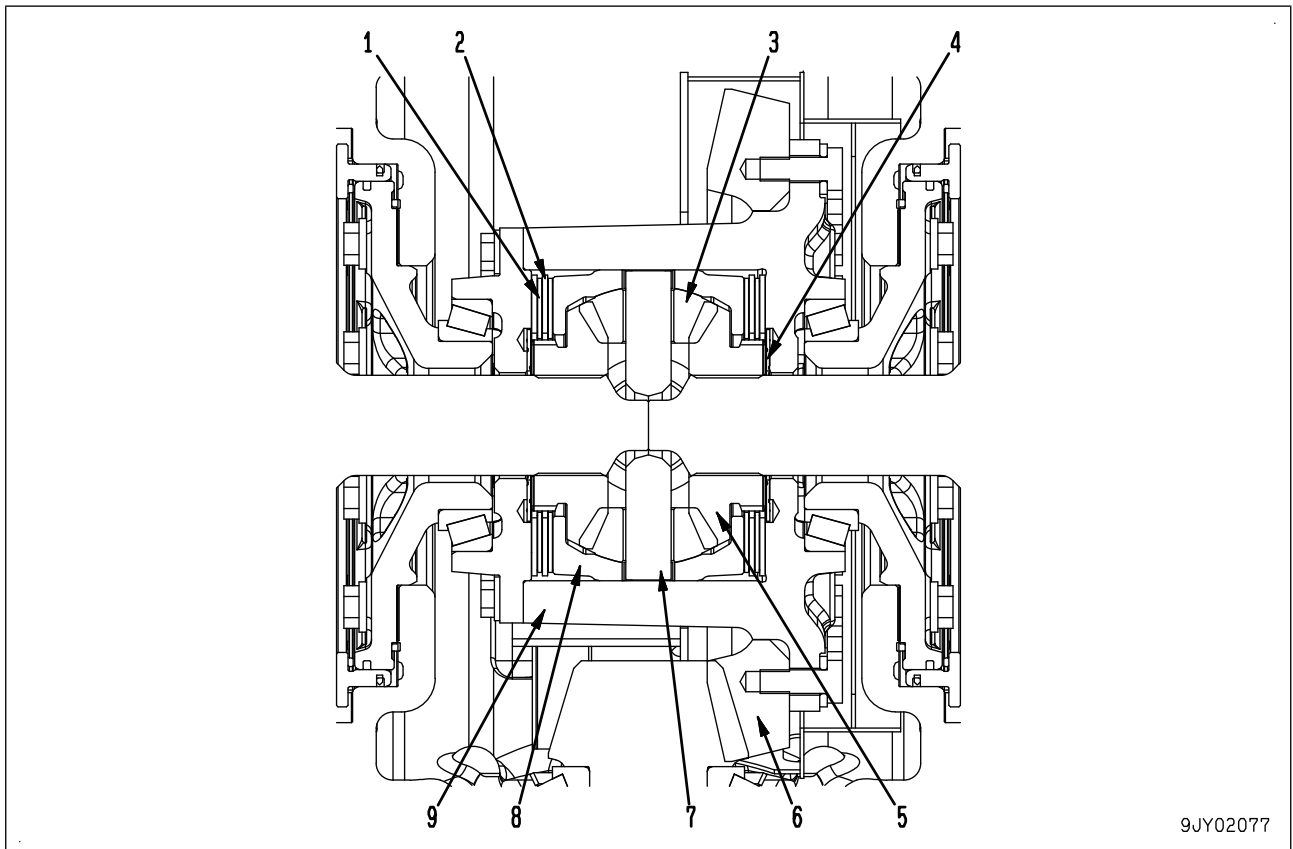

9JY02077

1. Plate
2. Disc
3. Pinion
4. Washer
5. Side gear
6. Bevel gear
7. Shaft
8. Pressure ring
9. Case

**Operation** (WA380-DCH2-042-K-00-A)

- The power from the transmission is transmitted through bevel gear (6) to case (9), pressure ring (8), shafts (7), pinions (3), and side gears (5), and then distributed to the right and left shafts.
- On the back of each side gear (5), the brake unit consisting of discs (2) and plates (1) is installed. It generates braking torque in proportion to the torque transmitted from pressure rings (8) to shaft (7).
- Since the braking torque restricts the rotation of side gears (5) and case (9), side gears (5) on the right and left sides do not rotate freely and the differential operation of the differential system is restricted.

# 10 Structure and function

## Steering valve

- Since ports (Pa) and (Pb) are connected to the drain circuit through the orbit-roll valve, steering spool (1) is returned to the neutral position by left return springs (2).

### Operation of flow control spool

#### When steering spool is in neutral

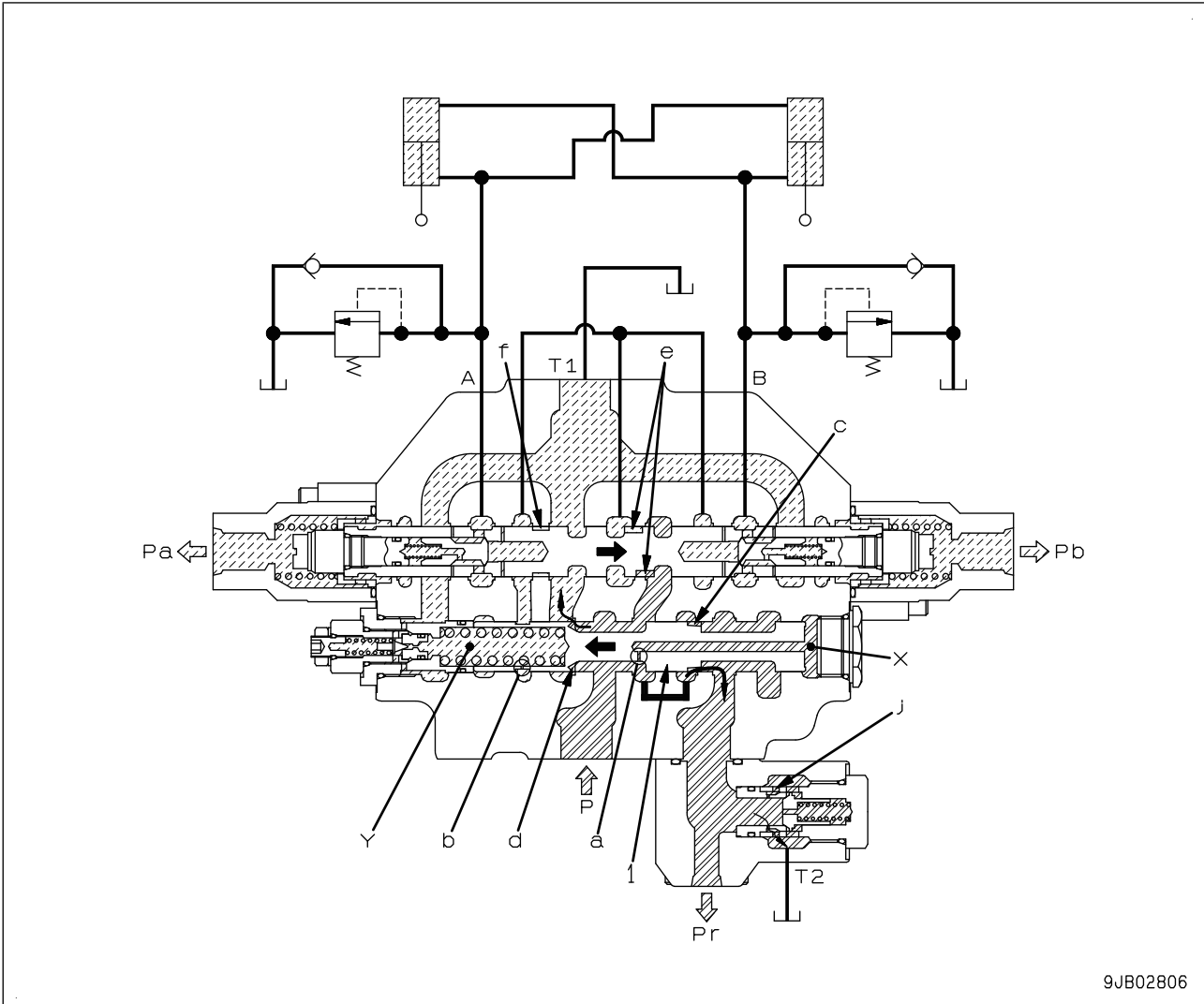

9JB02806

- The oil from the steering pump flows in port (P).
- Since notch (e) is closed, the oil pressure in port (P) increases and flows through orifice (a) to pressure receiving chamber (X), and moves flow control spool (1) to the left.
- The oil in pressure receiving chamber (Y) is drained through orifice (b), notch (f) and port (T1).
- If the oil pressure in pressure receiving chamber (X) exceeds the set pressure, flow control spool (1) moves to the left, and notch (c) opens.
- The oil in port (P) flows through notch (c) and port (Pr) to the LS valve of the steering pump. Port (Pr) is connected to port (T2) through orifice (j).
- The oil pressure in port (Pr) becomes the middle between the pump pressure and the drain pressure of port (T2) by the passing resistance through notch (c) and orifice (j).
- When the oil pressure in port (Pr) exceeds the set pressure, the swash plate angle of the steering pump is decreased to reduce the delivery.
- If the oil pressure in port (P) increases further even after the pump delivery becomes the minimum, flow control spool (1) moves to the left further.
- When the oil pressure in pressure receiving chamber (X) exceeds the set pressure, notch (d) opens and the oil in port (P) is drained through notch (d) and port (T1).

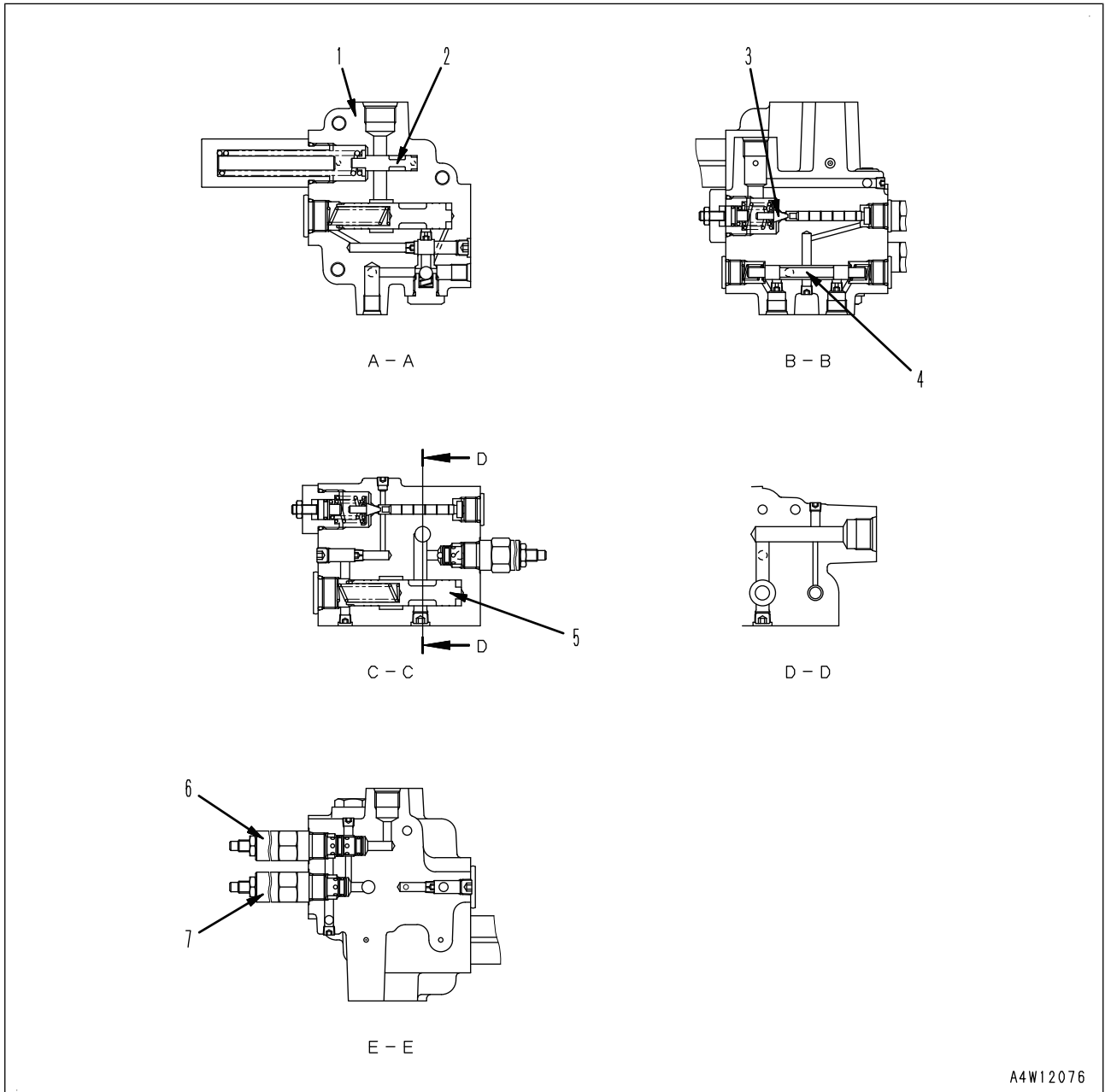

A4W12076

1. Valve body
2. Sequence valve (H1)
3. Relief valve (R2)
4. Shuttle valve (S1)
5. Priority valve
6. PPC relief valve (R3)
7. Main relief valve (R1)

**Function** (WA380-G2H0-042-K-00-A)

- The charge valve maintains the oil pressure from the pump at the set pressure and saves the pressure in the accumulator.
- When the pressure is saved in the accumulator, the circuit to the cooling fan motor opens to output the pressurized oil from the pump to drive the cooling fan motor.
- When the oil pressure rises above the specified pressure, the oil from the pump is led to the drain circuit to reduce the load on the pump.
- The charge valve reduces the oil from the pump in pressure and outputs the source pressure for the pilot circuit.

## 10 Structure and function

### Hydraulic component layout

---

2. 4-spool EPC valve (boom and bucket)
3. Bucket cylinder
4. Shuttle valve
5. Control valve
6. Work equipment lock solenoid valve
7. Steering valve
8. ECSS accumulator
9. Orbit-roll valve
10. Stop valve (right)
11. Brake valve
12. Cooling fan and brake pump
13. Steering pump
14. Hydraulic tank
15. Fan motor
16. Hydraulic oil cooler
17. Power train oil cooler
18. Work equipment pump
19. Double type gear pump (power train charge pump and power train lubrication pump)
20. PPC accumulator
21. Brake accumulator (for front)
22. Brake accumulator (for rear)
23. Brake emergency release valve
24. Accumulator charge valve
25. Stop valve (left)
26. Steering cylinder (left)
27. Steering cylinder (right)
28. Lift cylinder (left)
29. 2-spool EPC valve (3rd) (multi-function specification)

#### Outline

- The hydraulic system consists of the work equipment circuit and steering circuit. The work equipment circuit controls the operation of the bucket and attachment.
- The oil in hydraulic tank (14) is sent to control valve (5) by work equipment pump (18). While the spools of control valve (5) for the bucket and boom are in the HOLD position, the oil flows through the drain circuit of control valve (5) and is filtrated by the filter in hydraulic tank (14) and returned to the tank.
- When the work equipment control lever is operated, the work equipment controller sends a command current to EPC valve (2).
- EPC valves (2) and (29) operate each spool of control valve (5) hydraulically according to the command current.
- The oil flows from control valve (5) to lift cylinders (1) and (28) or bucket cylinder (3) to move the boom or bucket.
- The maximum pressure in the hydraulic circuit is controlled with the relief valve in control valve (5). The bucket cylinder circuit is equipped with a safety valve (with suction valve) to protect itself.
- Hydraulic tank (14) is of pressurized and sealed type, and equipped with an oil filler cap/breather having a relief valve, which pressurizes the tank, prevents generation of negative pressure in the tank, and prevents cavitation in the pump.
- When the machine cannot be steered normally during travel because of an engine stall, steering pump trouble, oil leakage from the piping, etc., the electric emergency steering motor is operated to drive the emergency steering pump and enables steering (if equipped).
- The fan motor (15) installed to the radiator is driven with variable hydraulic pressure by cooling fan / brake pump (12).

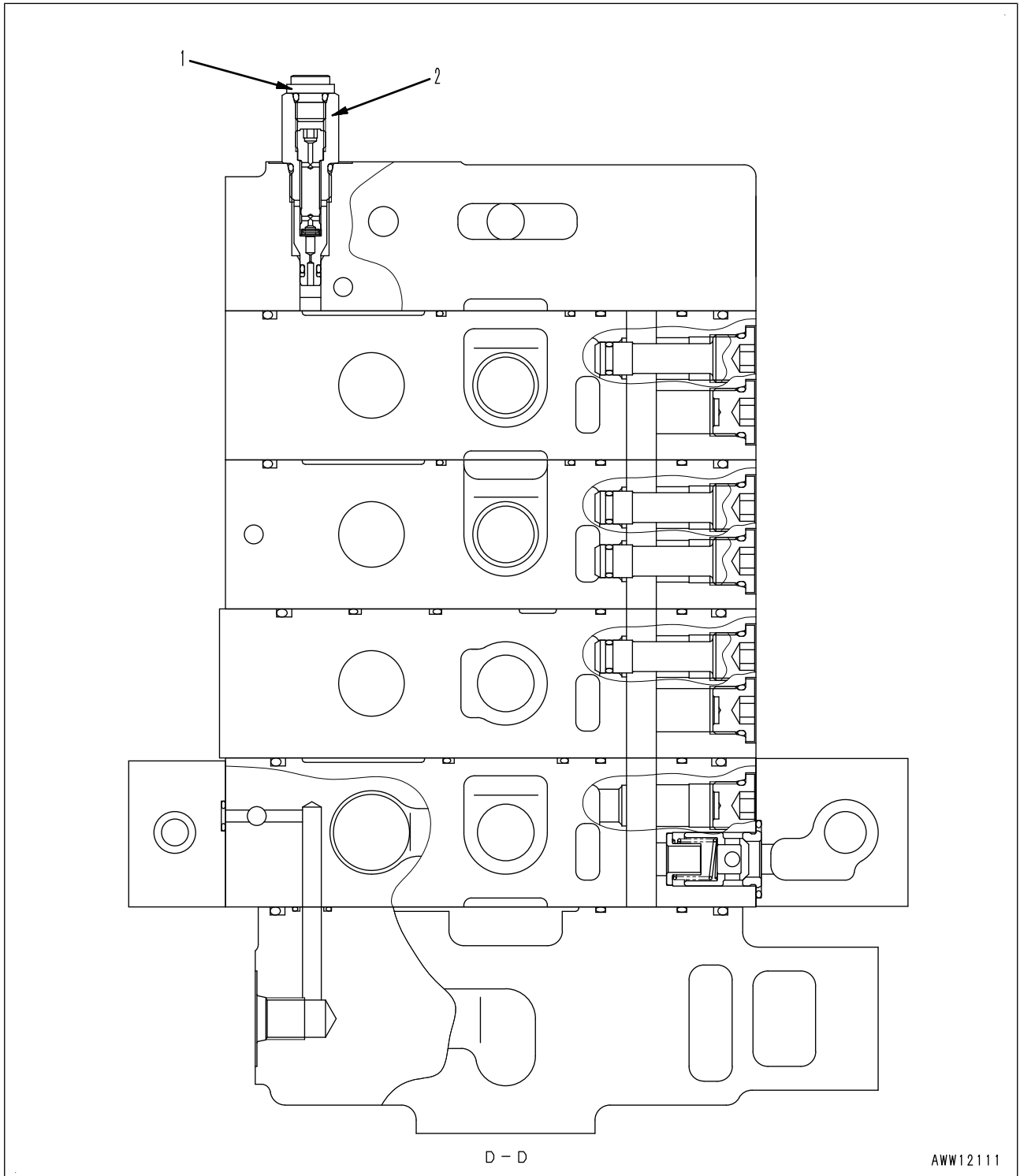

1. LS pressure pickup plug
2. LS bypass plug

## 10 Structure and function

### Hydraulic circuit diagram and name of valves

---

#### Function (WA380-L320-042-K-00-A)

- The controller automatically turns ON/OFF the accumulator charged with the high-pressure gas according to the travel condition of the machine.
- This valve gives elasticity to the vertical movement of the work equipment to restrict the machine body from rocking, improve the operator comfort, and prevent the load from spilling during high-speed travel.

#### Operation (WA380-L320-044-K-00-A)

- When the travel speed exceeds 5 km/h, the signal enters solenoid valve (2) and the pressure is applied to (a).
- Spool (1) moves to the right.
- When spool (1) moves, the passage of (PR) → accumulator (ACC) closes and the passage of (A2) → accumulator (ACC), (B2) → (T) opens, and ECSS is turned ON.
- When the travel speed is 5 km/h or below, no signal enters solenoid valve (2) and spool (1) is kept in natural. At this time, the passage of (PR) → accumulator (ACC) opens and accumulator (ACC) is charged.
- When accumulator (ACC) is charged up to the set pressure, check valve (5) closes and the pressure in the accumulator (ACC) does not increase any more.

#### Pressure release valve of accumulator

- When the pressure in accumulator (ACC) needs to be released for machine maintenance etc., loosen nut (4) and plug (3) to open the circuit (PR) and (TS), and release the pressure in accumulator (ACC).

**Automatic warm-up function** (WA380-AP13-042-K-00-A)

- When the engine is started in a cold district, the low idle speed of the engine is increased automatically to warm up the engine.
- If the coolant temperature is 20 °C or below when the engine is started, the low idle speed increases to 1,000 rpm. The condition for the low idle speed to increase is determined according to the coolant temperature as shown in the following figure.
- If the coolant temperature reaches 30°C or higher or the accelerator pedal position is kept at 70% or above for 3 seconds or longer during the warm-up operation, the automatic warm-up function is canceled and the engine speed returns to 850 rpm.

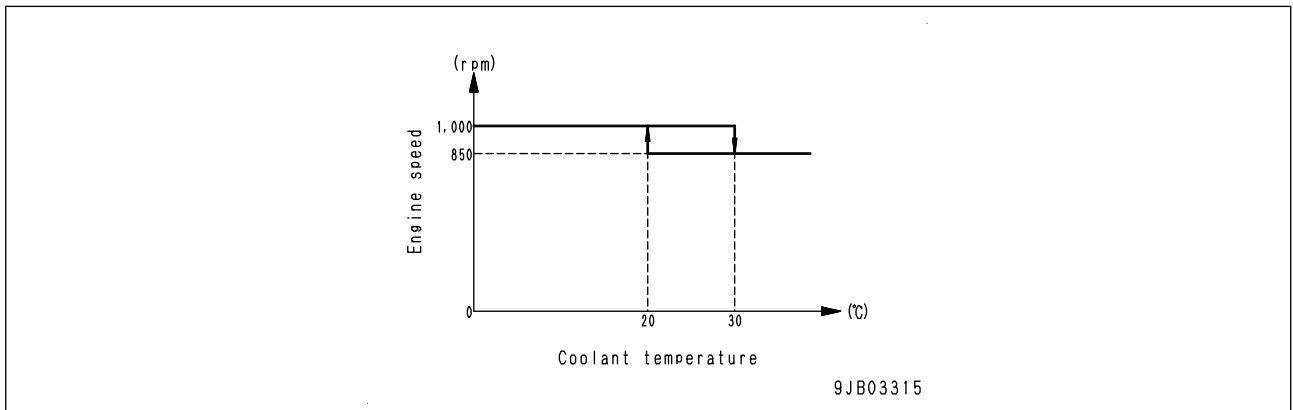

# 10 Structure and function

## Transmission controller system

Travel direction	Reverse
Engine mode	E
Shift mode	Auto H
L/U switch	ON

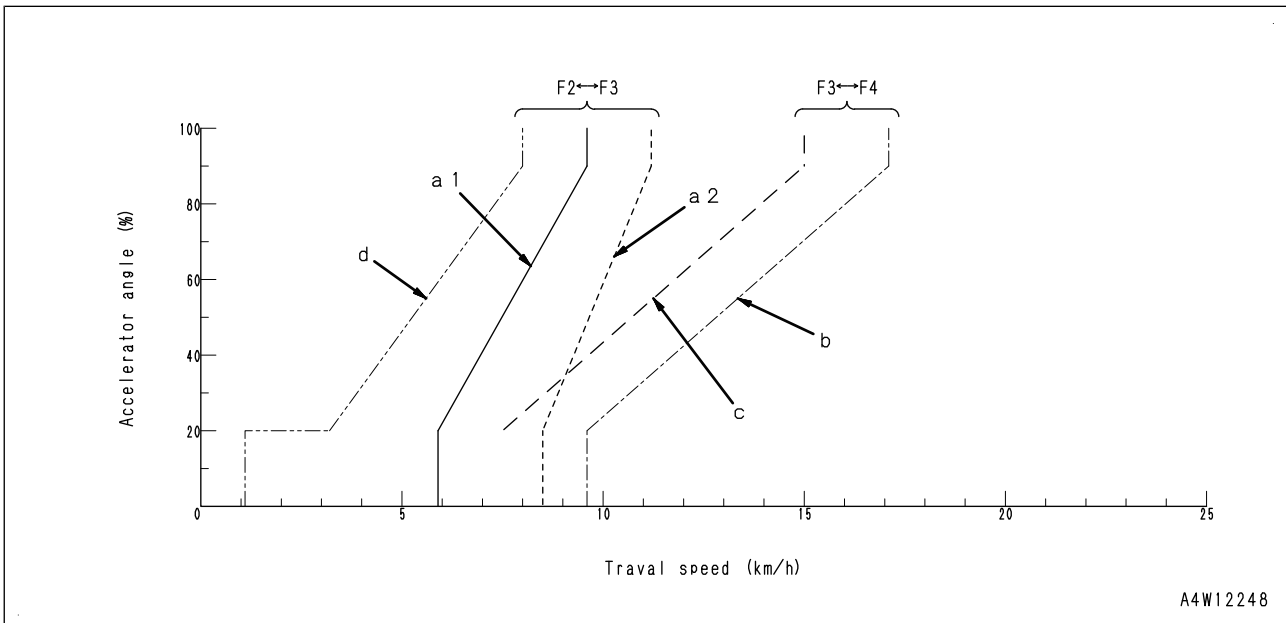

Travel direction	Reverse
Engine mode	E
Shift mode	Auto L
L/U switch	ON

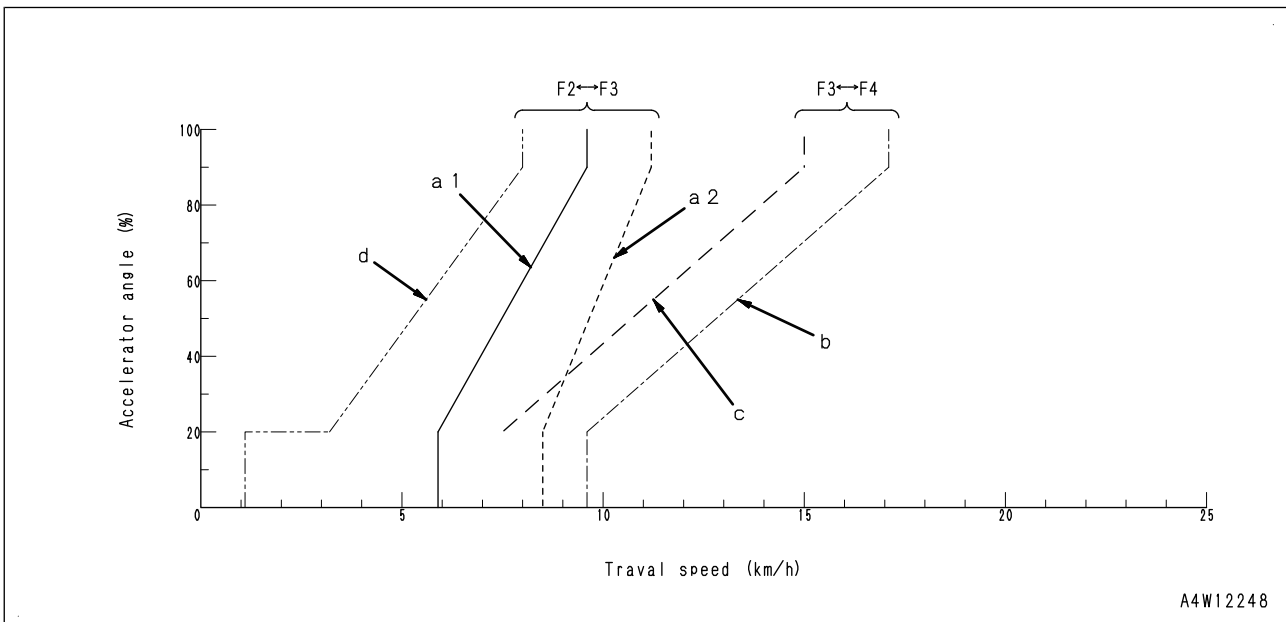

- a1: Upshift (Other than hunting prevention)
- a2: Upshift (Hunting prevention)
- b: Upshift
- c: Downshift
- d: Downshift

6. Work equipment neutral lock valve

**Function** (WA380-PTLD-042-K-00-A)

- When the work equipment lock switch is operated, the controller turns OFF the output of the work equipment EPC to stop the operation of the work equipment.
- When the ECSS switch is turned OFF, the work equipment neutral lock valve is turned ON. Then, the EPC pilot source pressure is cut and the operation of the work equipment is stopped.
- When the lever is operated while the work equipment is locked even if the operator tries to unlock the work equipment, the work equipment is not unlocked but kept locked for safety.

Operator's intention in operation of work equipment lock switch	Work equipment control lever condition when work equipment lock switch is operated	Controller	Operation of ECSS	Controller output				Movement of machine	
				Recognizes	Work equipment lock solenoid valve	Work equipment lock indicator			Work equipment EPC, work equipment detent
						Switch	Monitor		
In locking (no switch operation)	—	In locking	ECSS switch = OFF	ON (24 V)	ON (Lights up)	ON (Lights up)	OFF (No output)	Cut (Work equipment and ECSS stop)	
			ECSS SW = ON	OFF (OPEN)				Only ECSS operates	
Lock → Unlock (Switch operation)	Work equipment control lever is not in neutral	In locking	ECSS switch = OFF	ON (24 V)	ON (Lights up)	ON (Lights up)	OFF (No output)	Cut (Work equipment and ECSS stop)	
			ECSS SW = ON	OFF (OPEN)				Only ECSS operates	
Lock → Unlock (Switch operation)	Work equipment control lever is in neutral	In unlocked	—	OFF (OPEN)	OFF (Lights out)	OFF (Lights out)	Outputs according to lever operation	Operates	
In unlocking (no switch operation)	—	In unlocked	—	OFF (OPEN)	OFF (Lights out)	OFF (Lights out)	Outputs according to lever operation	Operates	
Unlock → Lock (Switch operation)	—	In locking	ECSS switch = OFF	ON (24 V)	ON (Lights up)	ON (Lights up) + * Popup	OFF (No output)	Cut (Work equipment and ECSS stop)	
			ECSS SW = ON	OFF (OPEN)				Only ECSS operates	

\* If the work equipment is locked with the switch operation by the operator, popup display appears on the machine monitor.

# 10 Structure and function

## Machine monitor system

### Display (WA380-Q1LA-042-K-00-A)

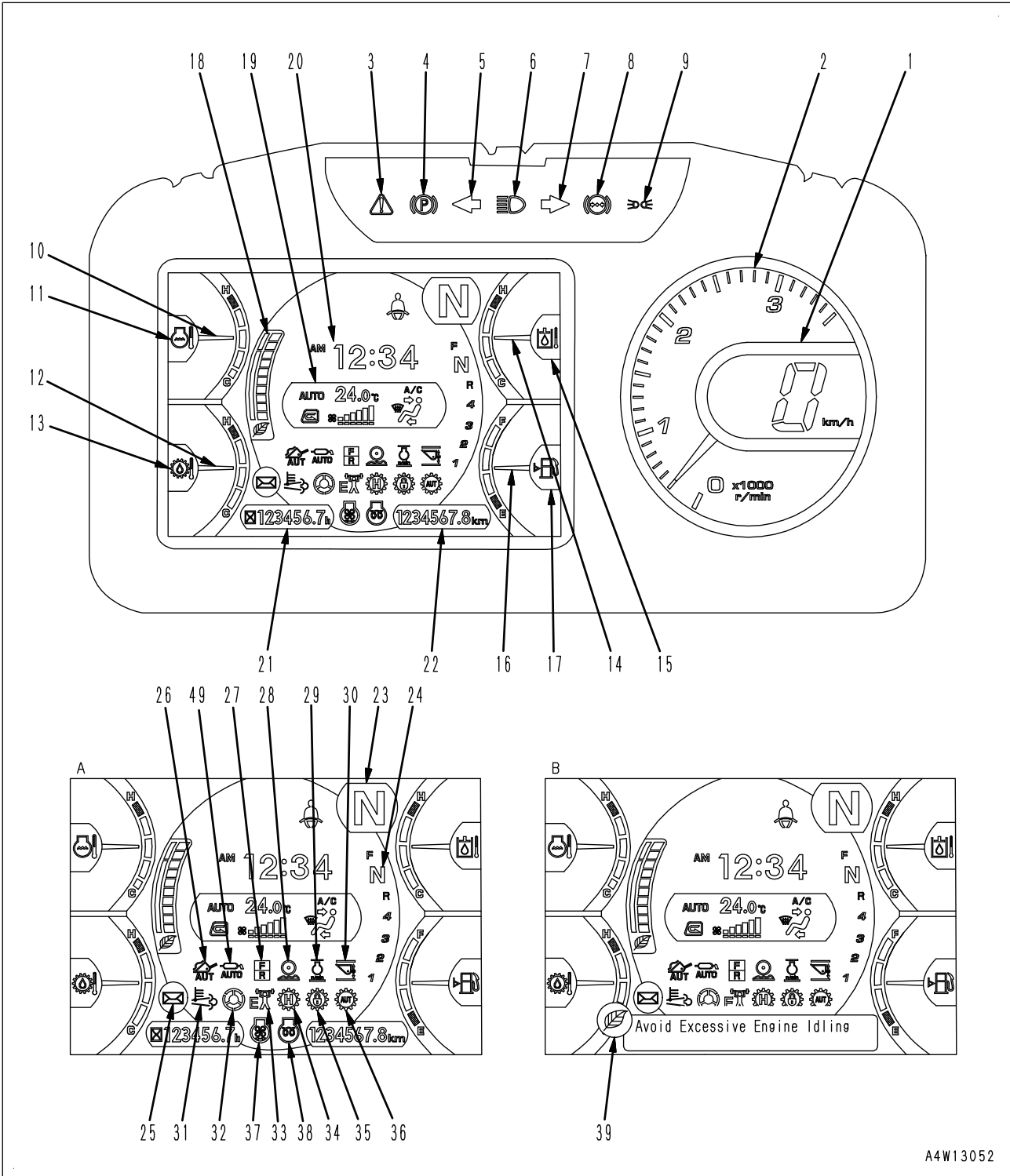

A4W13052

**KOMTRAX system** (HM300-Q210-042-K-00-A)

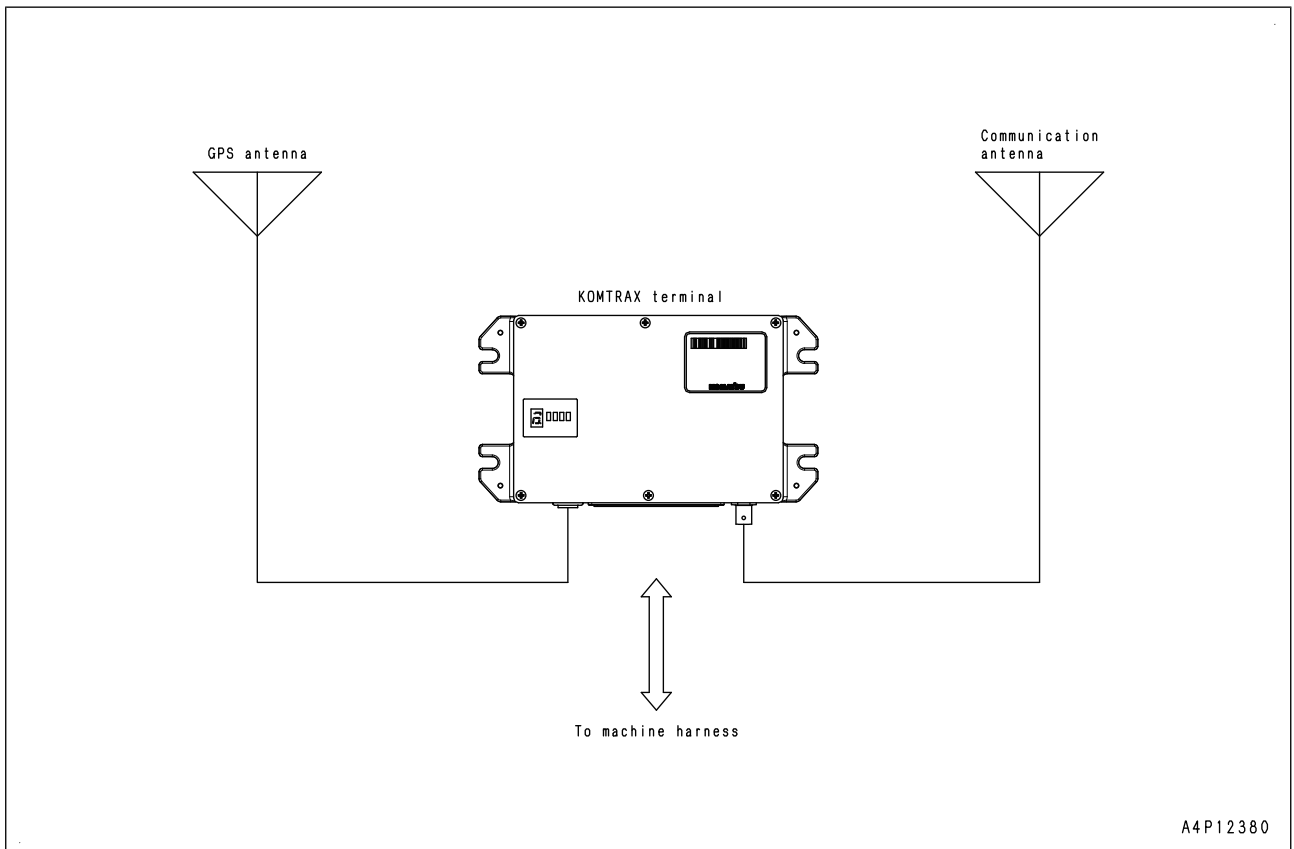

- The KOMTRAX system consists of the KOMTRAX terminal, communication antenna, and GPS antenna.
- This system transmits various machine information by use of the radio communication. KOMTRAX operator can refer this information and provide various services to the customers.
- Following information can be transmitted from the KOMTRAX system.
  1. Position information
  2. Operation information (service meter, odometer, etc.)
  3. Alarm and failure information
  4. Fuel consumption information
  5. Maintenance information
  6. Machine working condition information

★ To provide the services, you need to establish radio station for KOMTRAX separately.

**KOMTRAX terminal** (HM300-Q220-042-K-00-A)

**Model: TC330**

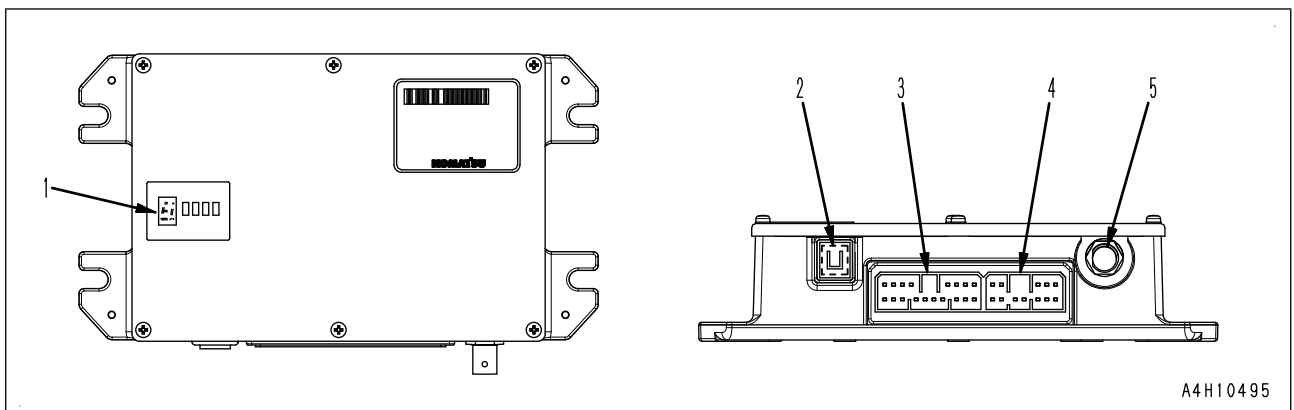

1. LED lamp display
2. GPS antenna connection port

**Operating effort characteristics**

**"Boom LOWER", "Boom RAISE", and "Bucket TILT" operations**

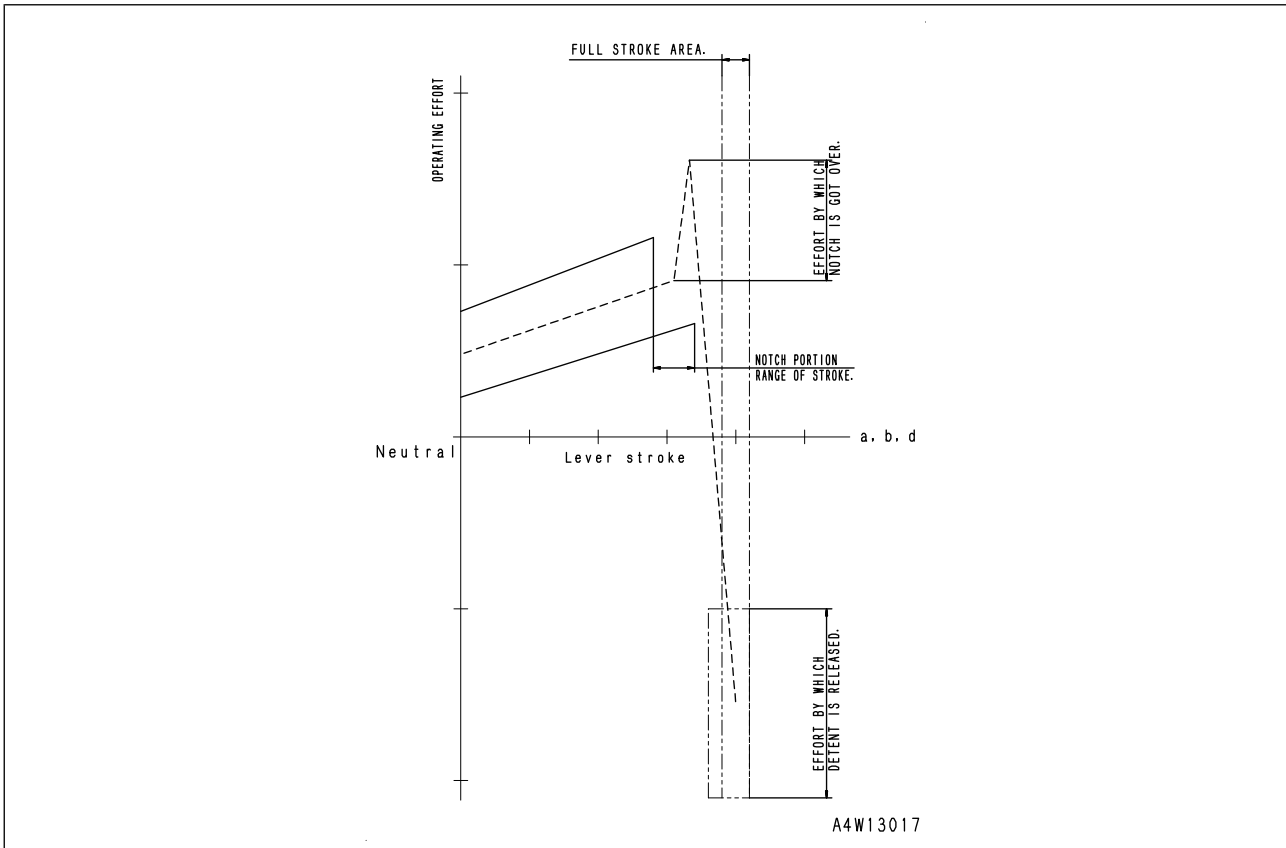

- The control lever is held at the three operation stroke ends of "Boom LOWER", "Boom RAISE", and "Bucket TILT". (Electric detent)

**"Bucket DUMP" operation**

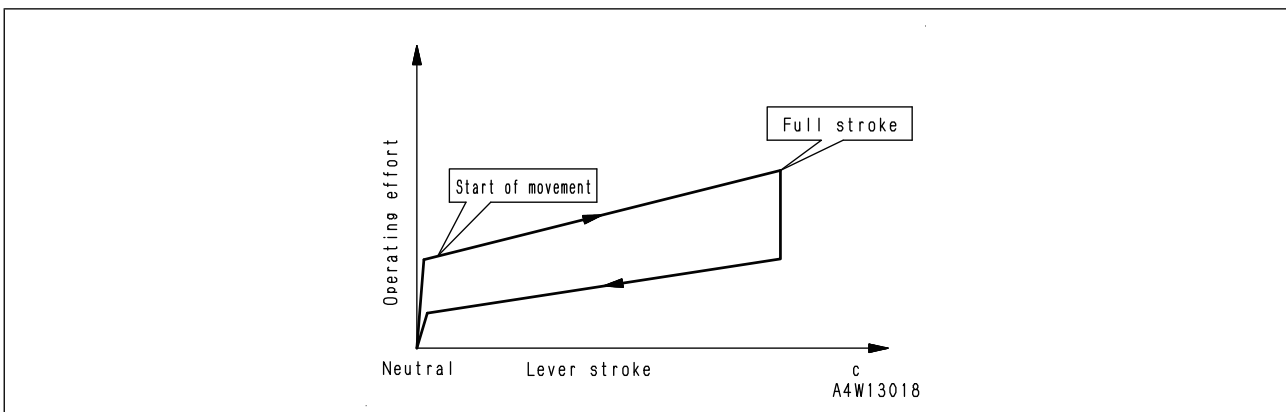

- Free return

**Output voltage characteristics**

- The operating angle (stroke) of the control lever is detected with the sensor and signal voltages are output to the controller.
- Each sensor outputs two signal voltages which are opposite to each other as shown in the figure.

**Function** (ENG-AB45-042-K-00-A)

- This sensor, installed on the side face of the oil pan, turns "OFF" by the lowered float, if the oil level becomes lower than specified.

**Transmission input speed sensor** (WA380-CNB1-041-K-00-A)

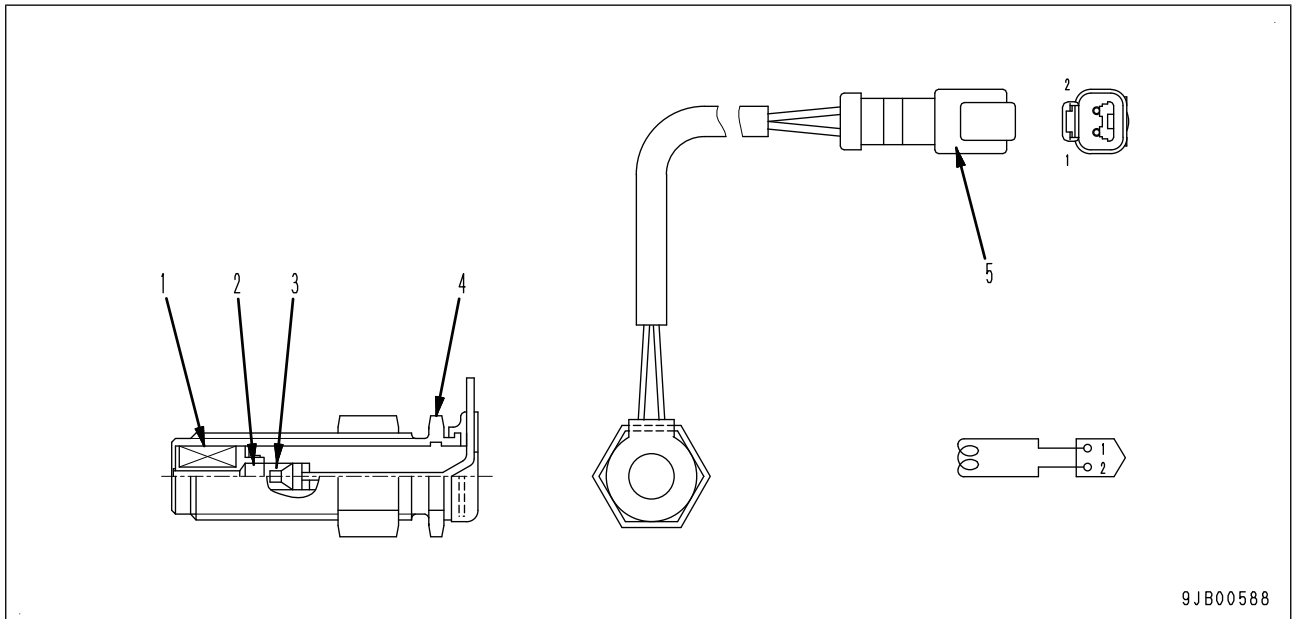

1. Wire
2. Magnet
3. Terminal
4. Housing
5. Connector

**Function** (WA380-CNB1-042-K-00-A)

- This sensor is installed to the input shaft gear area of the transmission front case. It outputs the pulse voltage generated by rotation of the gear.

**Transmission output shaft speed sensor** (WA380-CNA1-041-K-00-A)

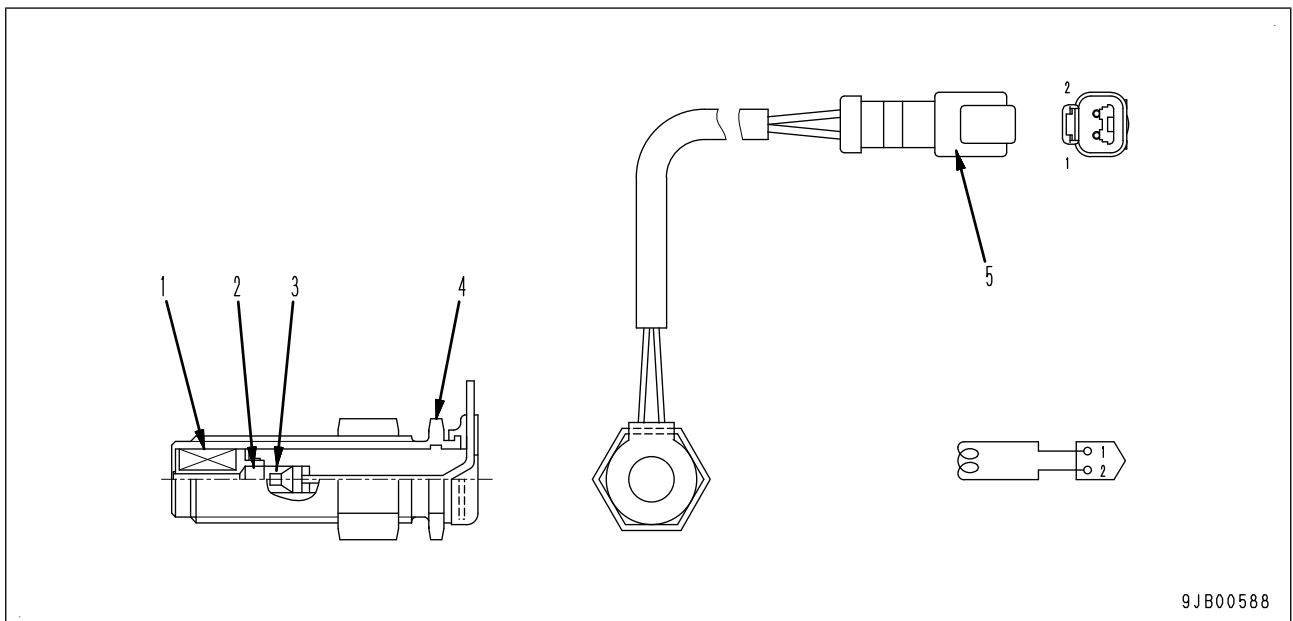

1. Wire
2. Magnet
3. Terminal

## 20 Standard value tables

### Standard value table for machine

#### Transmission and torque converter

Machine model			WA380-7		
Item		Measurement condition	Unit	Standard value for new machine	Repair limit
Main relief oil pressure	Low idle	<ul style="list-style-type: none"> <li>Torque converter oil temperature: Within operating range (60 to 80°C)</li> <li>Engine speed: 2,000 rpm</li> </ul>	MPa {kg/cm <sup>2</sup> }	2.31 ± 0.2 {23.5 ± 2}	2.31 ± 0.2 {23.5 ± 2}
	Engine speed: 2,000 rpm			2.50 ± 0.2 {25.5 ± 2.0}	2.50 ± 0.2 {25.5 ± 2.0}
Torque converter relief (inlet) oil pressure				Max. 1.02 {Max. 10.4}	Max. 1.02 {Max. 10.4}
Torque converter outlet oil pressure				0.30 to 0.69 {3.1 to 7.0}	0.30 to 0.69 {3.1 to 7.0}
ECMV output (clutch) oil pressure	1st, 2nd 3rd, 4th	<ul style="list-style-type: none"> <li>Torque converter oil temperature: Within operating range</li> <li>Engine speed: 2,000 rpm</li> <li>Manual switch: ON</li> </ul>	MPa {kg/cm <sup>2</sup> }	2.35 ± 0.15 {24 ± 1.5}	2.35 ± 0.15 {24 ± 1.5}
	Forward, Reverse			2.25 ± 0.15 {23 ± 1.5}	2.25 ± 0.15 {23 ± 1.5}
	Lockup clutch			1.91 ± 0.2 {19.5 ± 2}	1.91 ± 0.2 {19.5 ± 2}

#### Steering

Machine model			WA380-7		
Item		Measurement condition	Unit	Standard value for new machine	Repair limit
Steering relief pressure		<ul style="list-style-type: none"> <li>Hydraulic oil temperature: Within operating range</li> <li>Engine speed: High idle</li> </ul>	MPa {kg/cm <sup>2</sup> }	24.5 ± 1.23 {250 ± 12.5}	24.5 (+1.23/-2.45) {250 (+12.5/-25)}
Steering control valve oil pressure		<ul style="list-style-type: none"> <li>Hydraulic oil temperature: Within operating range</li> <li>Engine speed: Low idle</li> <li>Steering wheel: NEUTRAL</li> </ul>		1.1 to 1.4 {11 to 14}	0.9 to 1.6 {9 to 16}

#### Accumulator

Machine model			WA380-7		
Item		Measurement condition	Unit	Standard value for new machine	Repair limit
Charge cut-in pressure		<ul style="list-style-type: none"> <li>Engine speed: Low idle</li> </ul>	MPa {kg/cm <sup>2</sup> }	5.9 (+0.5/0) {60 (+5/0)}	5.9 (+0.98/-0.5) {60 (+10/-5)}
Charge cut-out pressure		<ul style="list-style-type: none"> <li>Hydraulic oil temperature: Within operating range</li> </ul>		9.8 (+0.98/0) {100 (+10/0)}	9.8 (+1.5/-0.5) {100 (+15/-5)}

## Testing exhaust gas color (WA380-A900-001-K-02-A)

★ Testing tools

Symbol	Part No.	Part name
C	1	799-201-9002 Handy smoke checker
	2	Commercially available Smoke meter

⚠ Place the machine on a level ground, lower the work equipment to the ground, set the parking brake switch and work equipment lock switch in the LOCK position, stop the engine, and chock the wheels.

⚠ Be careful not to touch any hot part when installing or removing the testing tools.

⚠ When KDPF regeneration is started, the high-temperature exhaust gas spurts from the inspection port, that may cause burn injury. Therefore, you must stop KDPF regeneration through the machine monitor before starting the inspection.

(For the stopping procedure for KDPF regeneration, see the Operation and Maintenance Manual.)

★ Measure the exhaust gas color under the following conditions.

- Engine coolant temperature: 60 to 102 °C
- Torque converter oil temperature: 80 to 100°C
- With torque converter stalled

★ If an air source and a electric power source are not available in the field, use handy smoke checker C1. When recording official data, etc., use smoke meter C2.

### Testing (WA380-A900-385-K-00-A)

1. Open the engine left side cover and remove four bolts (1) and insulation plate (2).

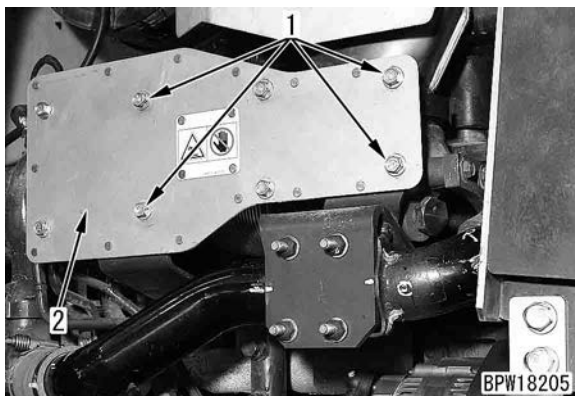

2. Remove bracket (3), cover (4), and plug (5).



Plug:

26.5 to 43.1 Nm {2.7 to 4.4 kgm}



Plug:

Seizure prevention compound (LC-G)

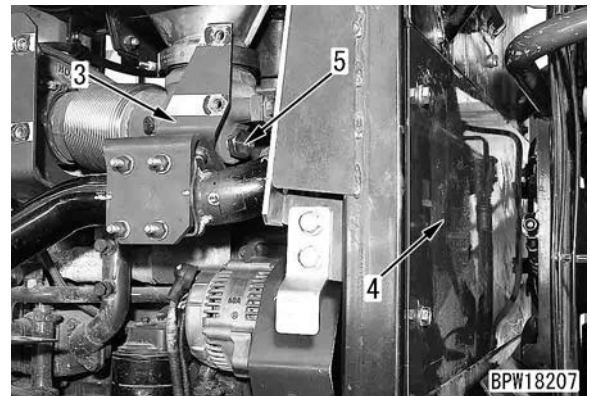

3. Measuring by using handy smoke checker C1

- 1) Fit a sheet of filter paper to handy smoke checker C1.
- 2) Insert the exhaust gas intake pipe into the port (6) from which the plug is removed, or into the tail pipe (7).
- 3) Start the engine, run it at under the torque converter stalled condition. Operate the handle of handy smoke checker C1 so that the filter paper will absorb the exhaust gas.

★ Suction time: 1.4 ± 0.2 seconds

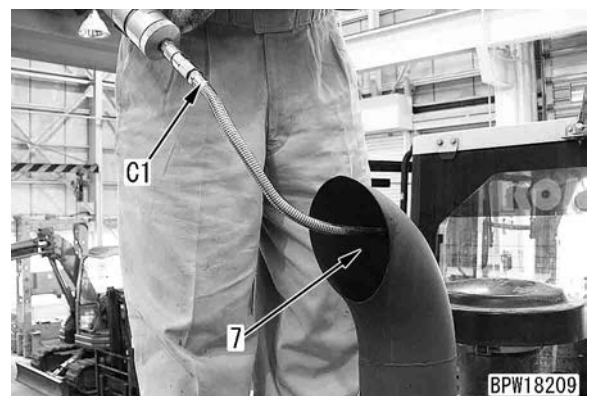
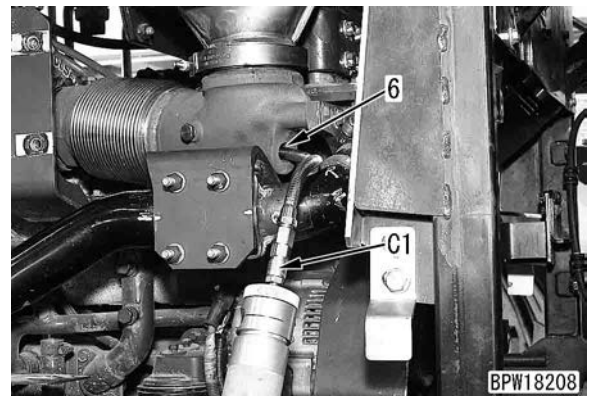

- 4) Remove the filter paper and compare it with the attached scale for judgement.
- 5) After the test, remove the testing tools and restore the machine.

### Bleeding air from fuel system (WA380-AD00-001-K-00-A)

- ★ If fuel is used up or if a fuel circuit part is removed and installed, bleed air from the fuel circuit according to the following procedure.

**⚠ Place the machine on a level ground, lower the work equipment to the ground, set the parking brake switch and work equipment lock switch in LOCK position, stop the engine, and chock the wheels.**

### Bleeding air (WA380-AD00-231-K-00-A)

1. Supply fuel to the fuel tank.
  - ★ Continue the supply of fuel until the fuel gauge monitor turns to blue.  
(Check the fuel level with monitor after turning the starting switch to the ON position.)
2. Open the engine right side cover.
3. Loosen and pull out hand primer (1) and move it back and forth.
  - ★ Continue the above operation until the operation of hand primer (1) becomes heavy.
  - ★ You may not remove the plug on the top surface of the main fuel filter.

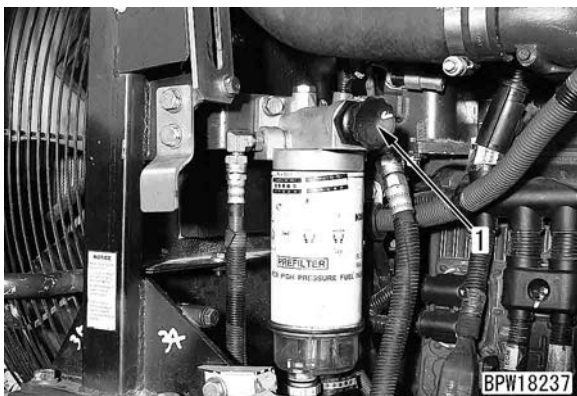

4. After the air bleeding, push in and tighten hand primer (1).

### Route for bleeding air from fuel circuit

Fuel tank→prefilter→feed pump→main filter→metering unit→fuel tank

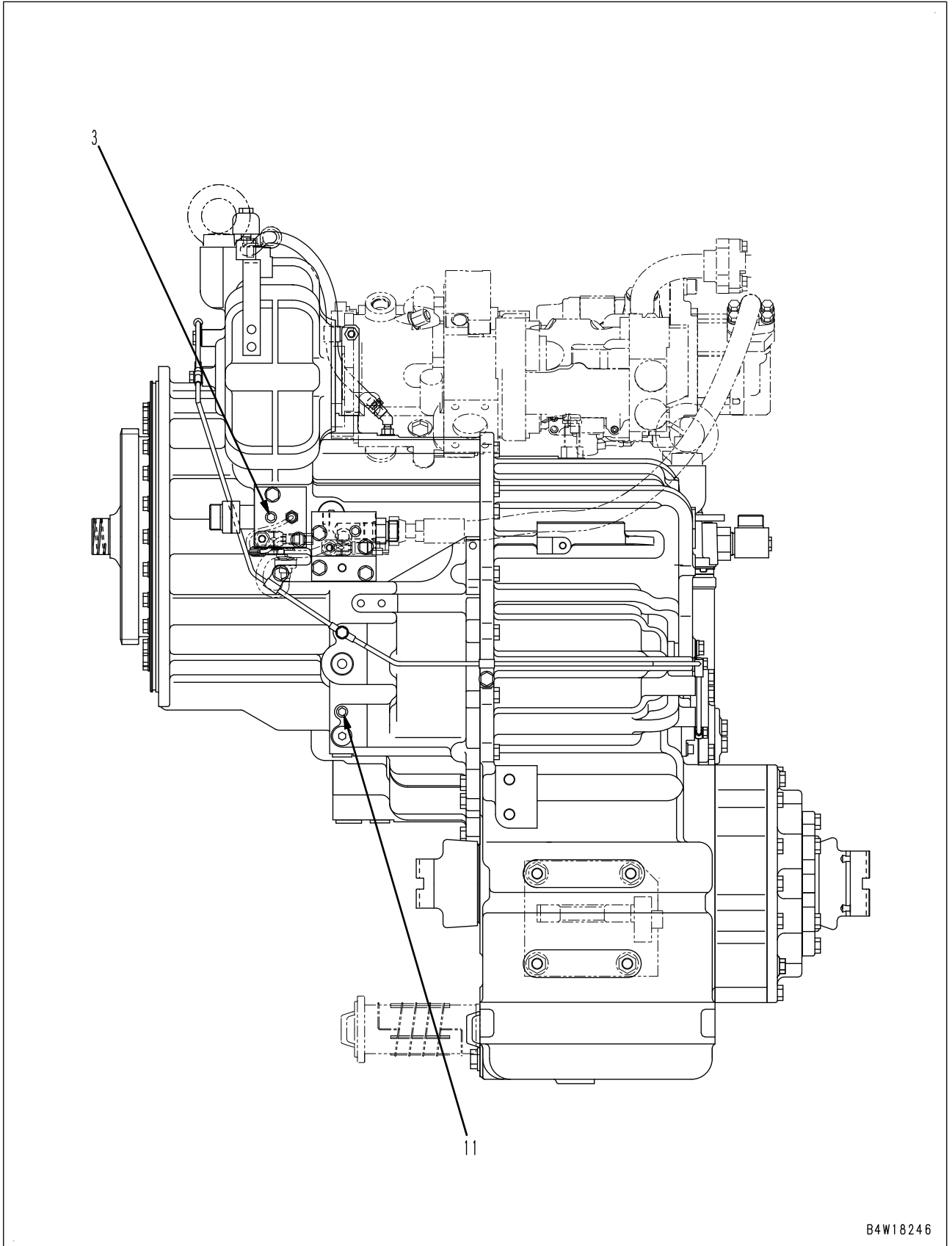

B4W18246

**Testing and adjusting steering stopper valve** (WA380-F5U0-001-K-00-A)

**Testing** (WA380-F5U0-365-K-00-A)

1. Align the front frame and rear frame.
2. Check that lock nut (1) on stopper bolt (2) is not loose.

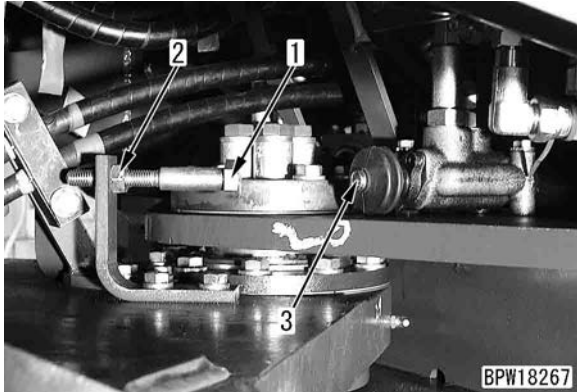

3. Start the engine and turn the steering wheel to the right and left. Check that a clearance is maintained between the front frame stopper and rear frame stopper.

**⚠ Stop the engine before measuring the clearance.**

- ★ If the check can not be made because of missing frame stopper and so on, do necessary repair and then make sure that the clearance is provided on both sides.

**Adjustment** (WA380-F5U0-270-K-00-A)

- ★ When the clearance between the front frame and rear frame is out of the specified range, adjust it in the following procedure.
1. Loosen lock nut (2) and then tighten stopper bolt (1) to set distance (a) to the minimum.

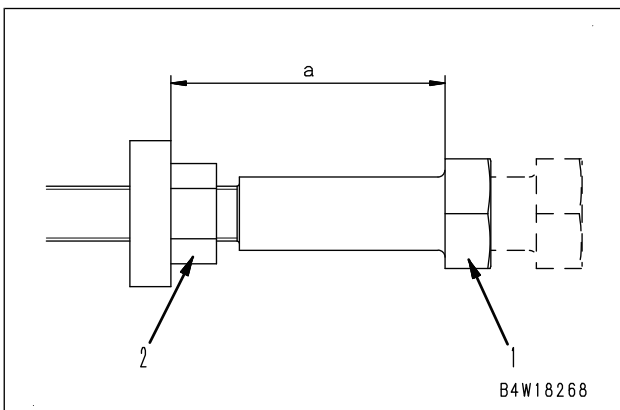

2. Run the engine at low idle and then bring the front frame and rear frame into contact by turning the steering wheel slowly.

**⚠ Use care in this operation so that your body or arm are not caught between the front and rear frames.**

3. Stop the engine and then loosen stopper bolt (1) until it touches the contact surface of steering stop valve (3).

- ★ Use care not to loosen the stopper bolt excessively. Excessive loosening can result in pushing the spool at the tip of steering stop valve (3).

4. Start and run the engine at low idle, and then return the steering wheel slowly to set the machine to the straight travel condition. Then stop the engine.
5. Turn stopper bolt (1) in the loosening direction by 8.5 turns (approx. 15 mm), then fix it by lock nut (2).

- ★ Adjust both the right and left sides by following the procedure from steps 1 to 5.

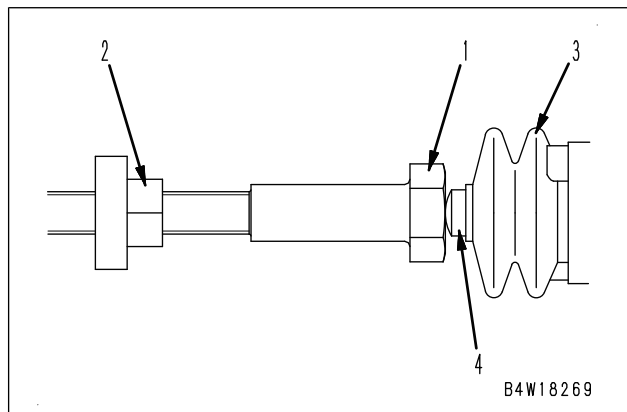

6. Start the engine, turn the machine and then check that there is a clearance between the front frame and rear frame when the turning is stopped due to the contact of steering stop valve (3) and stopper bolt (1).

## Testing cooling fan pump circuit oil pressure (WA380-B441-001-K-00-A)

★ Testing tools

Symbol	Part No.	Part name
R	1	799-101-5002 Hydraulic tester
	2	790-261-1204 Digital hydraulic tester

⚠ Place the machine on a level ground, lower the work equipment to the ground, set the parking brake switch and work equipment lock switch in LOCK position, stop the engine, and chock the wheels.

⚠ Loosen the cap of the hydraulic tank gradually to release the pressure in the tank.

★ Measure the cooling fan pump circuit pressure under the following conditions.

- Engine high idle
- Fan 100% mode
- Hydraulic oil temperature: 50°C

### Testing (WA380-B441-362-K-00-A)

1. Start the engine and display on the machine monitor the "Fan 100% Mode" under the "Adjustment" function of the service mode.
  - ★ For the operation method, see Testing and adjusting, "Special functions of machine monitor".
  - ★ If this mode is displayed, the fan speed is kept at 100% speed in accordance with the engine speed, regardless of the condition of the machine.

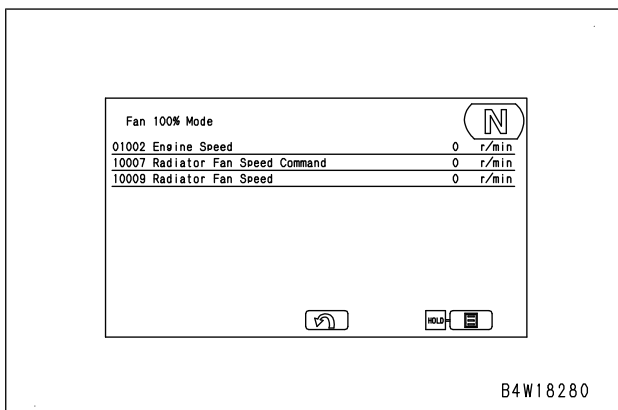

2. Open the engine right side cover.
3. Install hose [1] of hydraulic tester R1 to cooling fan pump circuit pressure pickup port nipple (1) and connect gauge [2] to it.
  - ★ The hose for digital hydraulic tester R2 can also be used.
  - ★ Use an oil pressure gauge of 40 MPa {400 kg/cm<sup>2</sup>}.

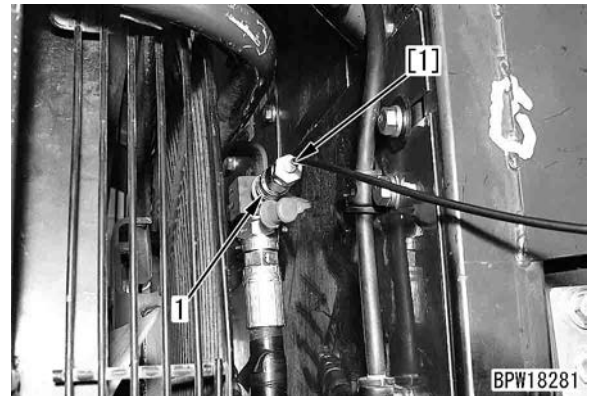

4. Run the engine at high idle and measure the cooling fan pump circuit oil pressure.

Cooling fan pump circuit oil pressure	15.7 ± 2.4 MPa {160 ± 24 kg/cm <sup>2</sup> }
---------------------------------------	--

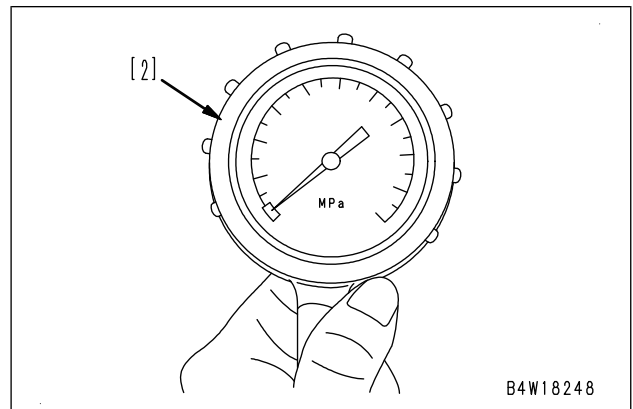

5. After finishing test, remove the testing tools and restore the machine.

## 30 Testing and adjusting

### Electrical system

#### Operator mode (outline) (WA380-Q193-042-K-01-A)

- ★ Only outline of the operator mode is described in this section.

For details of each function and display, and their operation, see "Structure and function", or the "Operation and Maintenance Manual".

- ★ The following are the displays or functions of the operator mode explained in this section (including some items which need special operations).

Operator mode (outline)
Display of KOMATSU logo(PAGE 30-130)
Display of password input(PAGE 30-130)
Display of standard screen(PAGE 30-131)
Display of end screen(PAGE 30-131)
Display of operation screen for engine shutdown secondary switch(PAGE 30-131)
Operation of air conditioner(PAGE 30-131)
Displaying and setting user menu(PAGE 30-132)
Display of ECO guidance(PAGE 30-132)
Display of warning (caution and action level)(PAGE 30-135)
Overdue replacement item screen(PAGE 30-137)
Displaying KDPF regeneration(PAGE 30-137)

↓ (Special operation)

LCD (Liquid Crystal Display) check function(PAGE 30-139)
Function of checking service meter and odometer (PAGE 30-139)
Function of usage limitation setting/ changing password(PAGE 30-140)

#### Display of KOMATSU logo (HM300-Q180-044-K-00-A)

When starting switch is turned to ON position, KOMATSU logo is displayed for 2 seconds.

- ★ After the 2-seconds display, the screen changes to "Password Input (if password is set)" screen or "standard screen".

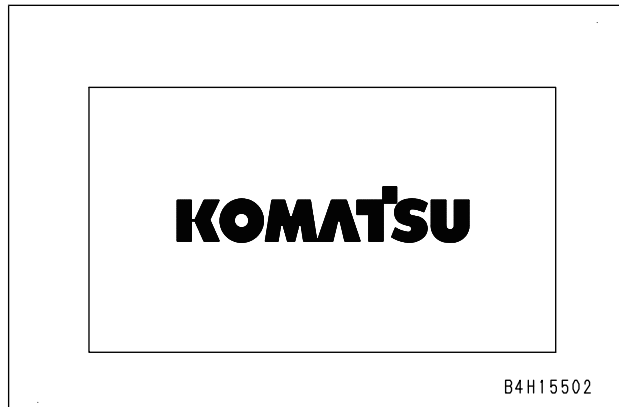

#### Display of password input (WA380-Q180-044-K-06-A)

After KOMATSU logo is displayed, the screen to input the "Engine Start Lock" password is displayed.

- ★ This screen is displayed only when the engine start lock function is enabled.
- ★ When a correct password is input, the display changes to the standard screen.
- ★ The machine monitor equips with several protect functions by passwords other than the engine start lock. Those functions are independent from each other.

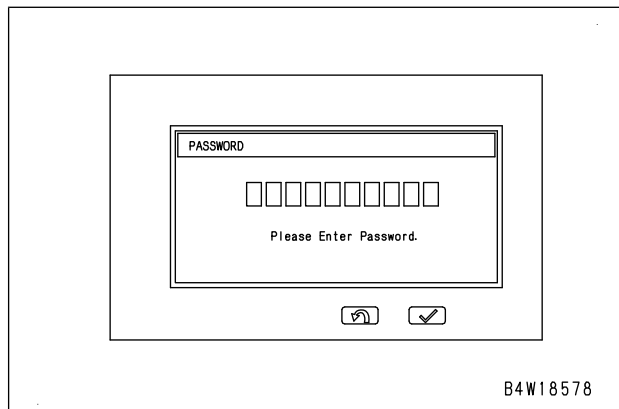

- ★ The following screen may sometimes be displayed instead of the above "Password input" screen.

Code No.	Monitoring item (Display on screen)	Unit (Default: SI)		Applicable component	Remarks
		SI	Non-SI		
41806	"Fill Time (Reverse)"	msec	msec	T/M	
41808	"Fill Time (Forward)"	msec	msec	T/M	
44201	"Throttle Lower Limit Command"	%	%	T/M	
44200	"Throttle Higher Limit Command"	%	%	T/M	
36000	"Throttle Adjustment Command"	%	%	T/M	
17302	"Dynamic Torque Command"	%	%	T/M	
94100	"T/M Initial Learning Status"	—	—	T/M	
	"F Clutch"	ON/OFF		T/M	
	"R Clutch"	ON/OFF		T/M	
	"1st Clutch"	ON/OFF		T/M	
	"2nd Clutch"	ON/OFF		T/M	
	"3rd Clutch"	ON/OFF		T/M	
02216	"Clutch Fill SW Input"	—	—	T/M	
	"F Clutch"	ON/OFF		T/M	
	"R Clutch"	ON/OFF		T/M	
	"1st Clutch"	ON/OFF		T/M	
	"2nd Clutch"	ON/OFF		T/M	
	"3rd Clutch"	ON/OFF		T/M	
02211	"T/M Con. SW Input 1"	—	—	T/M	
	"Main FNR Signal F"	ON/OFF		T/M	
	"Main FNR Signal N"	ON/OFF		T/M	
	"Main FNR Signal R"	ON/OFF		T/M	
	"Option FNR Signal F"	ON/OFF		T/M	
	"Option FNR Signal N"	ON/OFF		T/M	
02212	"T/M Con. SW Input 2"	—	—	T/M	
	"Shift Lever 1"	ON/OFF		T/M	
	"Shift Lever 2"	ON/OFF		T/M	
	"Shift Lever 3"	ON/OFF		T/M	
	"Shift Lever 4"	ON/OFF		T/M	
	"Kick Down Switch"	ON/OFF		T/M	
02213	"T/M Con. SW Input 3"	—	—	T/M	
	"Shift Mode Switch Manual"	ON/OFF		T/M	
	"Shift Mode Switch H."	ON/OFF		T/M	
02214	"T/M Con. SW Input 4"	—	—	T/M	
	"Starter Status"	ON/OFF		T/M	
	"E.C.S.S. Switch"	ON/OFF		T/M	
	"Lock Up Switch"	ON/OFF		T/M	
	"T/M Cut Off Switch"	ON/OFF		T/M	
	"T/M Cut Off Set Switch"	ON/OFF		T/M	
02215	"Option FNR Switch"	ON/OFF		T/M	
	"T/M Con. SW Input 5"	—	—	T/M	
03705	"Parking Brake Switch"	ON/OFF		T/M	
	"T/M Con. Switch Output 1"	—	—	T/M	
	"Neutral Safety Relay"	ON/OFF		T/M	
	"T/M Cut Off Indicator"	ON/OFF		T/M	
	"Backup Lamp Relay"	ON/OFF		T/M	
	"E.C.S.S. Solenoid"	ON/OFF		T/M	
	"Bypass Solenoid"	ON/OFF		T/M	

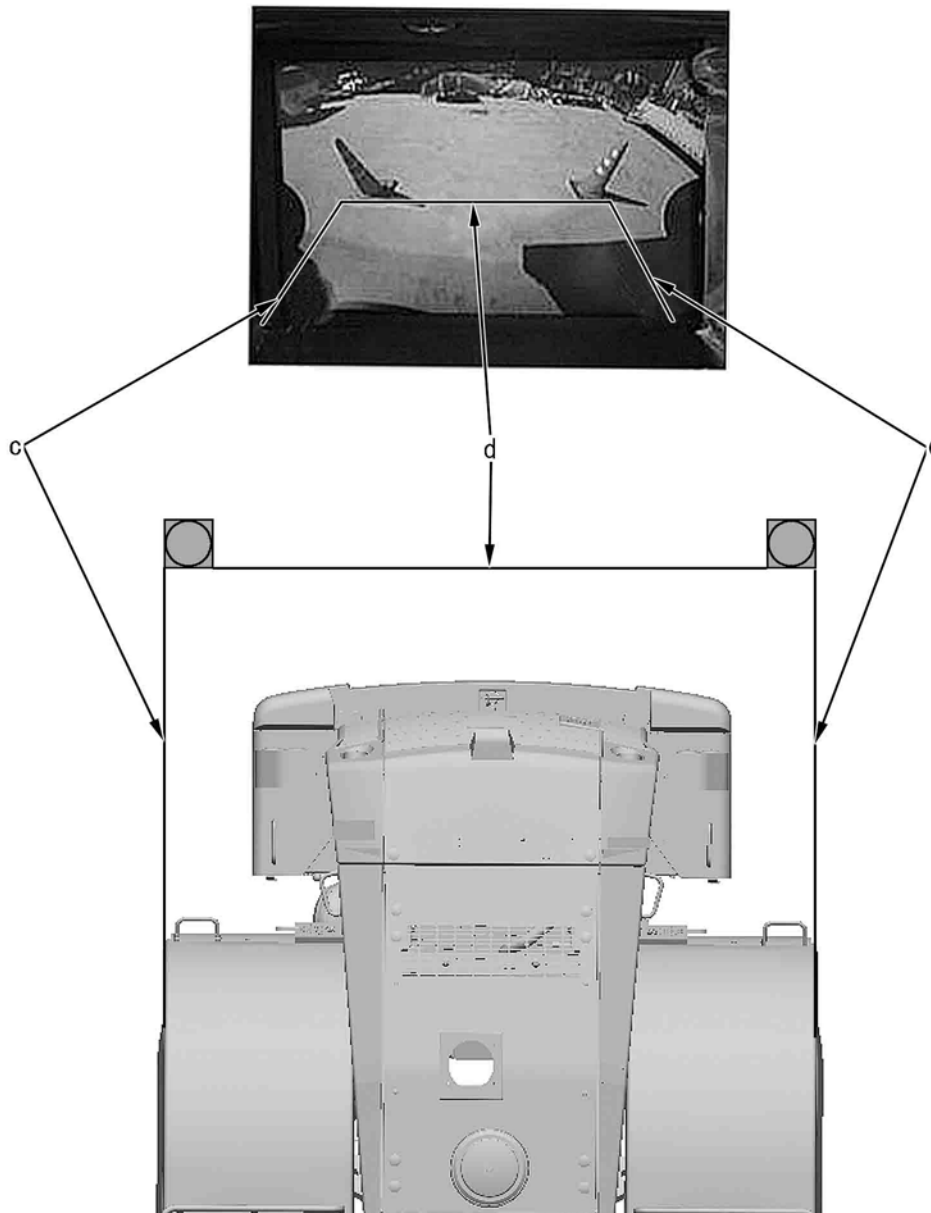

BPW18704

- 4) When the setting of the "Reverse-interlock enabled mode" of the user menu was changed at the first, return it to the original condition and the guide line position adjustment is completed.

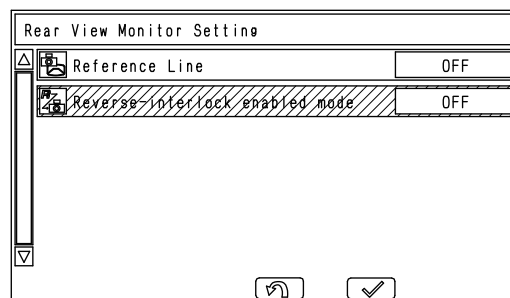

B4H15594

5. Initializing rear view monitor  
This function allows initializing the rear view monitor setting.

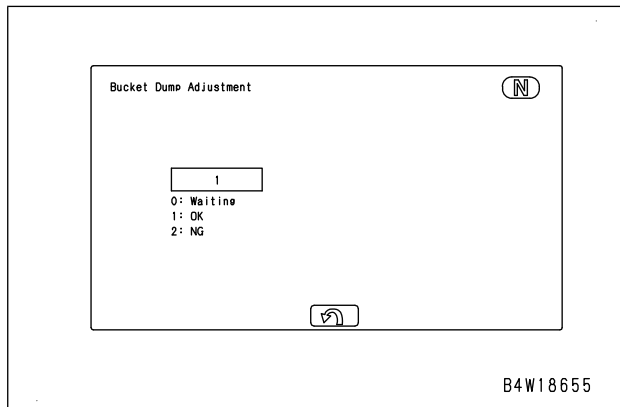

7. If "2" is displayed, the signal voltage of lever angle is out of the standard voltage range. This adjustment is not performed.

- ★ If the return switch is pressed while the calibration is continued, the calibration currently taking place is stopped even if it is not completed.

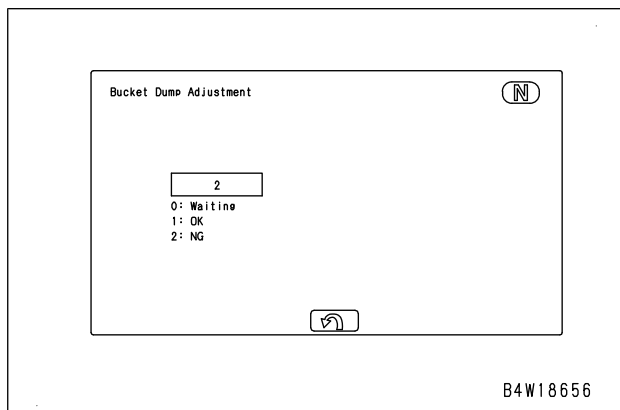

## Handling battery disconnect switch (WA380-AW1P-100-K-00-A)

1. When you turn the battery disconnect switch to the OFF position, be sure to pull out switch key (1).

**⚠ A serious accident can result if someone turns switch key (1) ON inadvertently.**

2. You can prevent an abnormal end of the operation due to cutoff of the battery power supply circuit while the controllers are in operation by checking the operating status of each controller with system operating lamp (2).
  - 1) Before cutting off the battery power supply circuit, turn the starting switch to the "OFF" position, and check that the system operating lamp goes out, then turn the battery disconnect switch to the "OFF" position.
  - 2) If you turn the battery disconnect switch to the "OFF" position (battery power supply circuit is cut off) while the system operating lamp is lit, Controller Data Lost Error can occur. Do not operate the battery disconnect switch as long as the system operating lamp is lit.
  - 3) The system operating lamp goes out in two minutes longest after the starting switch is turned to the "OFF" position.
  - 4) Even if the starting switch is in the OFF position, the system operating lamp may light up since the KOMTRAX terminal may perform communication.
  - 5) The system operating lamp may look slightly luminous in the dark after it is turned off. It is due to the minute leakage of current and not an abnormal phenomenon.
    - After the starting switch is turned to the "OFF" position, KOMTRAX terminal repeats the start and stop to maintain the periodic communication.
    - The start and stop cycle (sleep cycle) of KOMTRAX terminal varies depending on the factors including the communication status and machine stop time. So the lamp can be lit as long as approximately an hour.
  - 6) When you want to cut off the battery circuit for maintenance but the operating lamp keeps on lighting up, turn the starting switch to the "ON" position once, then turn it to the "OFF" position. The lamp will go out in two minutes maximum.

After the system operating lamp goes out, turn the battery disconnect switch to the OFF position immediately.

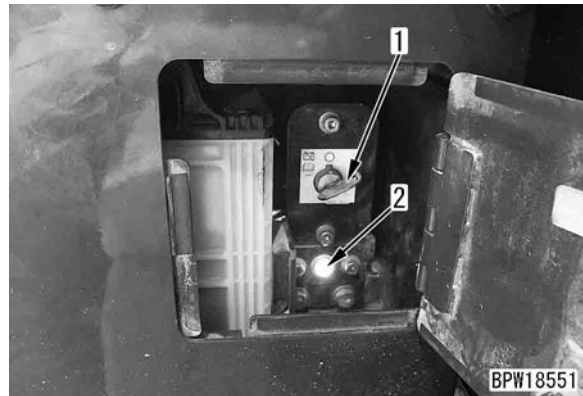

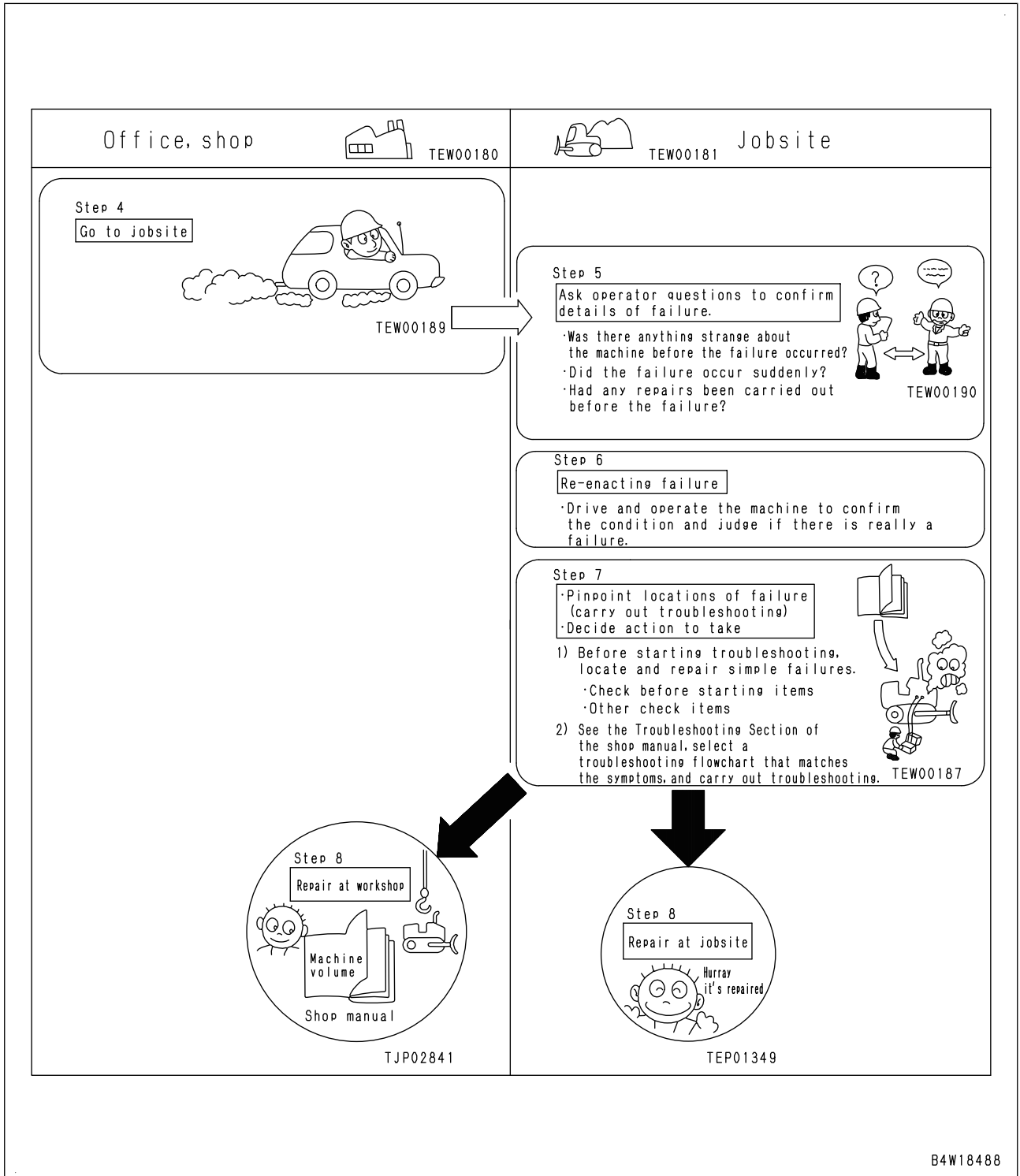

B4W18488

## 40 Troubleshooting

### Related information on troubleshooting

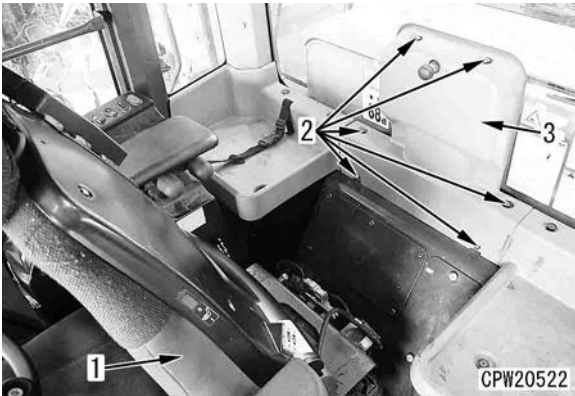

3) Remove bolts (4) (5 pieces) and remove cover (5).

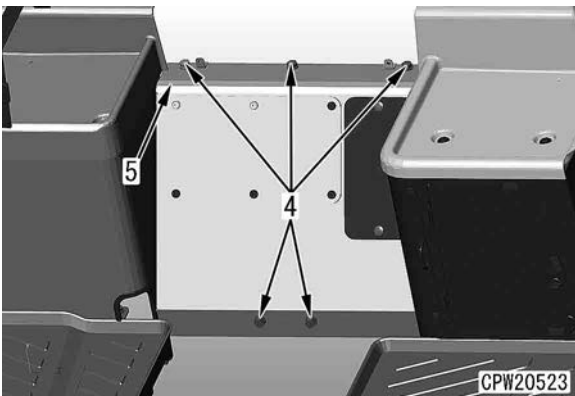

4) Disconnect connectors L80A (7), L80B (8) of KOMTRAX communication module (6), and insert or connect T-adapters for troubleshooting.

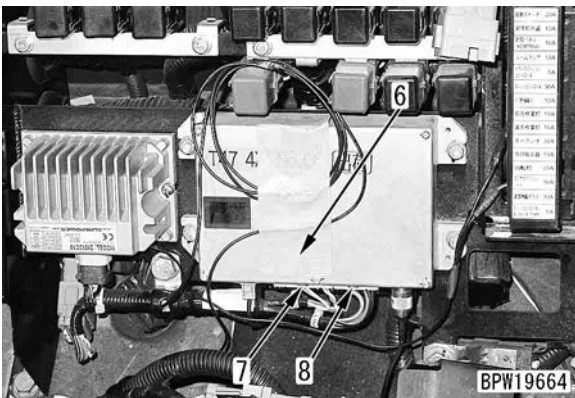

6. Ambient pressure sensor (AMBAIR PRESSURE)  
Engine Ne Speed Sensor (CRANK SENSOR)  
Engine Bkup speed sensor (CAM SENSOR)  
Engine oil pressure switch (OIL PRESSURE SWITCH)

#### ★ Disconnecting and connecting connectors

Since the connectors of ambient pressure sensor, engine Ne speed sensor, and engine Bkup speed sensor have a special lock mechanism, disconnect male and female connectors in the order (a) to (c), and connect them in the order (d) to (f) as shown in the following figure.

Disconnection: (a) Slide the lever, (b) unlock, and (c) disconnect the connectors.

Connection: (d) Connect the connectors, (e) engage the lock, and (f) slide the lever.

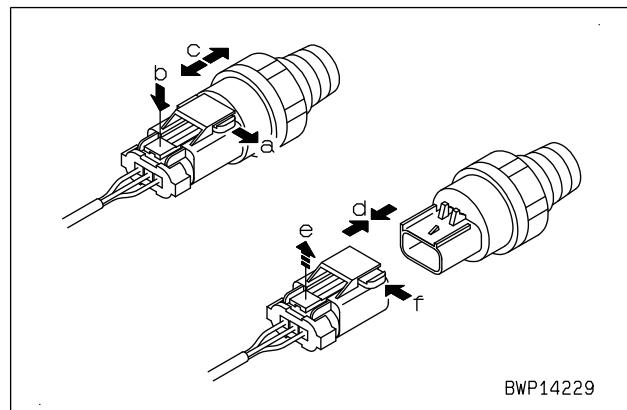

#### ★ Removal and installation of sensor body

Since a deep socket is necessary when performing removal and installation of engine oil pressure switch, see "Tools for testing, adjusting, and troubleshooting".

### 7. Boost pressure & temperature sensor

#### ★ Disconnecting and connecting connectors

Since the connector of boost pressure & temperature sensor has a special lock mechanism, disconnect male and female connectors in the order (a) to (b), and connect them in the order (c) to (d) as shown in the following figure.

Disconnection: (a) Unlock and (b) disconnect the connectors.

Connection: (c) Connect the connectors and (d) engage the lock.

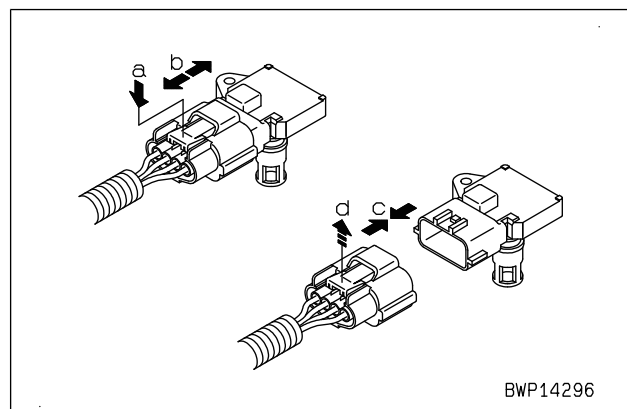

Layout of connectors (4/7)

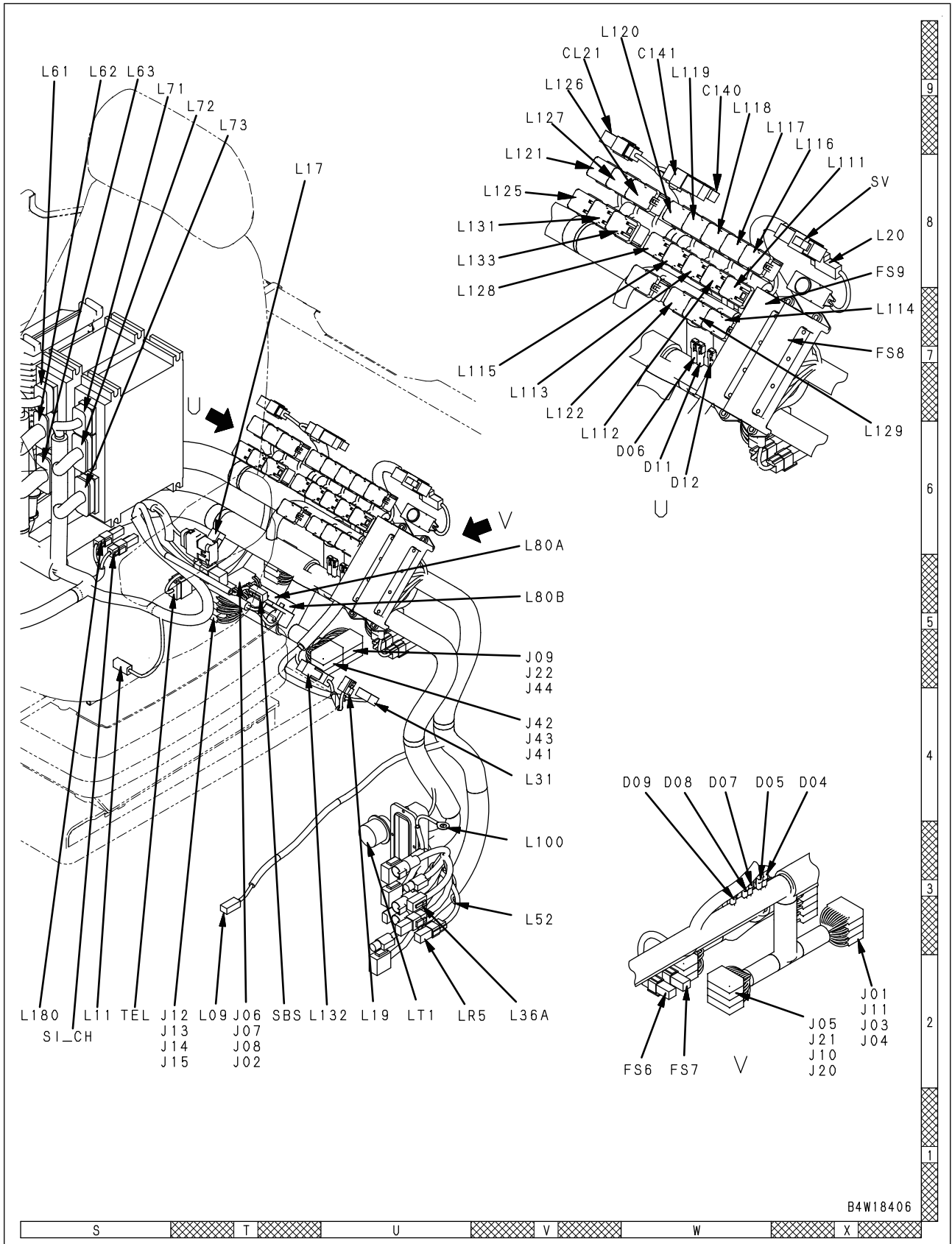

## 40 Troubleshooting

### Related information on troubleshooting

Failure code	Failure (Displayed on screen)	Applicable component	Action level	History category	Remarks
989M00	Failure code [989M00] Engine Controller Lock Caution 2(PAGE 40-140)	MON	—	Electrical system	
989N00	Failure code [989N00] Engine Controller Lock Caution 3(PAGE 40-141)	MON	—	Electrical system	
A1U0N3	Failure code [A1U0N3] HC Desorb Request 1 (PAGE 40-142)	ENG	L01	Mechanical system	
A1U0N4	Failure code [A1U0N4] HC Desorb Request 2 (PAGE 40-144)	ENG	L03	Mechanical system	
AA10NX	Failure code [AA10NX] Air Cleaner Clogging (PAGE 40-146)	MON	L01	Mechanical system	
AB00KE	Failure code [AB00KE] Charge Voltage Low (PAGE 40-148)	MON	L03	Electrical system	
AB00KY	Failure code [AB00KY] Hot Short of Alternator R Terminal(PAGE 40-150)	MON	L03	Electrical system	
B@BAZG	Failure code [B@BAZG] Eng Oil Press Low (PAGE 40-151)	ENG	L03	Mechanical system	
B@BAZK	Failure code [B@BAZK] Engine Oil Level Low (PAGE 40-152)	MON	L01	Mechanical system	
B@BCNS	Failure code [B@BCNS] Eng Water Overheat (PAGE 40-153)	ENG	L02	Mechanical system	
B@BCZK	Failure code [B@BCZK] Eng Water Level Low (PAGE 40-154)	MON	L01	Mechanical system	
B@C7NS	Failure code [B@C7NS] High Brake Oil Temp (PAGE 40-156)	MON	L02	Mechanical system	
B@CENS	Failure code [B@CENS] T/C Oil Temp. Overheat (PAGE 40-158)	MON	L02	Mechanical system	
B@HANS	Failure code [B@HANS] HYD Oil Temp. Overheat (PAGE 40-159)	MON	L02	Mechanical system	
CA115	Failure code [CA115] Eng Ne and Bkup Speed Sens Error(PAGE 40-160)	ENG	L04	Electrical system	
CA122	Failure code [CA122] Chg Air Press Sensor High Error(PAGE 40-161)	ENG	L03	Electrical system	
CA123	Failure code [CA123] Chg Air Press Sensor Low Error(PAGE 40-163)	ENG	L03	Electrical system	
CA131	Failure code [CA131] Throttle Sensor High Error (PAGE 40-165)	ENG	L03	Electrical system	
CA132	Failure code [CA132] Throttle Sensor Low Error (PAGE 40-167)	ENG	L03	Electrical system	
CA144	Failure code [CA144] Coolant Temp Sens High Error(PAGE 40-169)	ENG	L01	Electrical system	
CA145	Failure code [CA145] Coolant Temp Sens Low Error(PAGE 40-171)	ENG	L01	Electrical system	
CA153	Failure code [CA153] Chg Air Temp Sensor High Error(PAGE 40-173)	ENG	L03	Electrical system	
CA154	Failure code [CA154] Chg Air Temp Sensor Low Error(PAGE 40-175)	ENG	L03	Electrical system	
CA187	Failure code [CA187] Sensor 2 Supply Volt Low Error(PAGE 40-177)	ENG	L03	Electrical system	
CA221	Failure code [CA221] Ambient Press Sensor High Error(PAGE 40-179)	ENG	L03	Electrical system	
CA222	Failure code [CA222] Ambient Press Sensor Low Error(PAGE 40-181)	ENG	L03	Electrical system	
CA227	Failure code [CA227] Sensor 2 Supply Volt High Error(PAGE 40-183)	ENG	L03	Electrical system	
CA234	Failure code [CA234] Eng Overspeed(PAGE 40-184)	ENG	L02	Mechanical system	

**Circuit diagram related to 1st clutch**

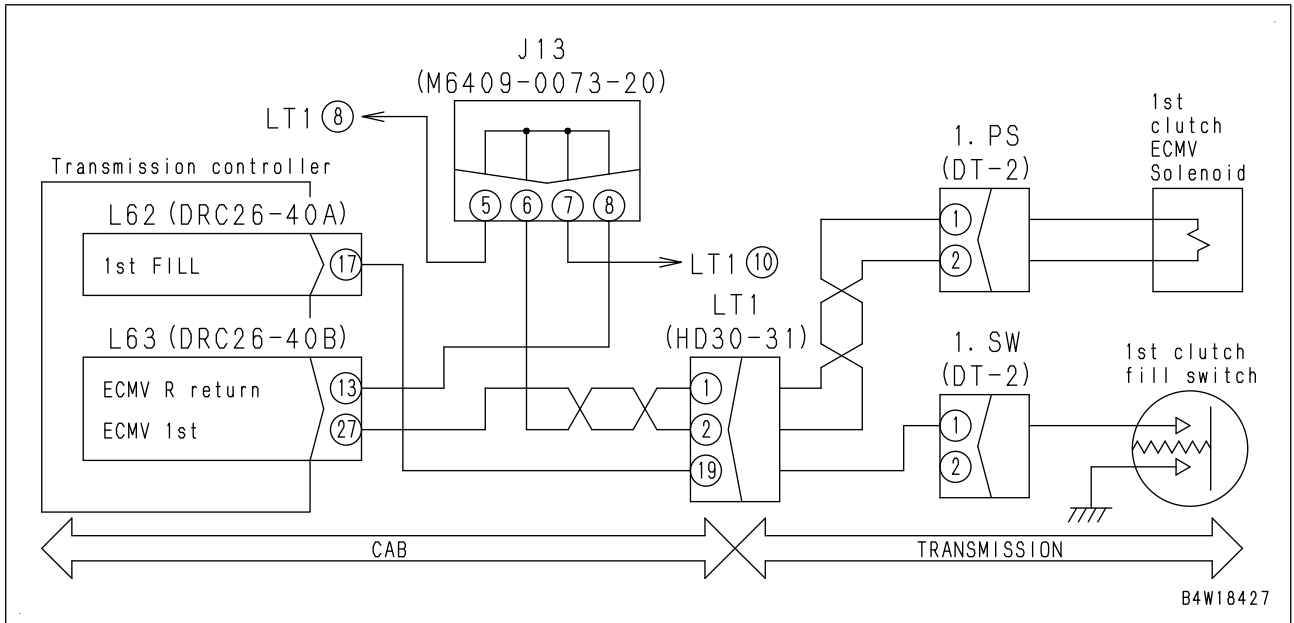

## 40 Troubleshooting

Troubleshooting by failure code (Display of code)

---

### **Failure code [879AKB] A/C Inner Sensor Short Circuit** (WA380\_7-879AKB-441-A-Z0-A)

See "Failure code [879AKB] A/C Inner Sensor Short Circuit" in chapter 80 of "Appendix".

**Failure code [B@BCNS] Eng Water Overheat** (WA380\_7-BaBCNS-400-A-Z0-A)

Action level	Failure code	Failure	Engine Water Overheat (Engine controller system)
L02	B@BCNS		
Detail of failure	<ul style="list-style-type: none"> <li>Engine controller determines that engine coolant overheats because signal voltage from engine coolant temperature sensor drops while engine is running.</li> </ul>		
Action of controller	<ul style="list-style-type: none"> <li>Lights up engine coolant temperature overheat caution lamp in red on machine monitor.</li> <li>Lights up centralized warning lamp and sounds alarm buzzer.</li> <li>If cause of failure disappears, machine becomes normal by itself.</li> </ul>		
Problem on machine	<ul style="list-style-type: none"> <li>If machine is operated as it is, engine may seize up.</li> </ul>		
Related information	<ul style="list-style-type: none"> <li>Signal voltage of engine coolant temperature sensor is input to engine controller that transmits information to machine monitor through CAN communication system.</li> <li>Engine coolant temperature can be checked with monitoring function. (Code: 04107 Engine coolant temperature)</li> <li>Method of reproducing failure code: Start engine.</li> </ul>		
No.	Cause	Procedure, measuring location, criteria and remarks	
1	Overheating of engine coolant (When system is normal)	Engine coolant may overheat. Check coolant temperature and remove cause of failure if coolant overheats.	
2	Defective engine coolant temperature sensor system	If no failure is found by check on cause 1, engine coolant temperature sensor system may be defective. Perform troubleshooting for failure codes [CA144] and [CA145].	

# 40 Troubleshooting

## Troubleshooting by failure code (Display of code)

### Circuit diagram related to boost temperature sensor

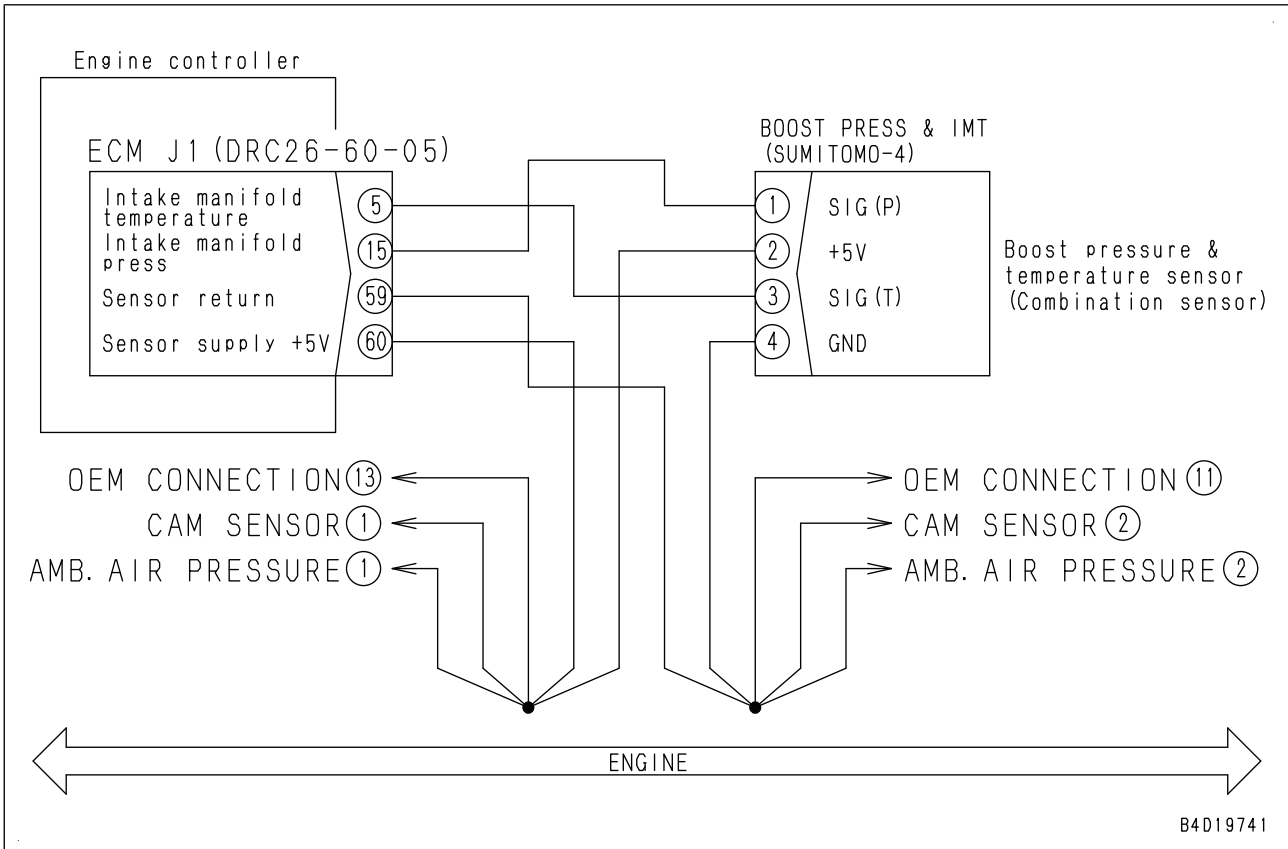

No.	Cause	Procedure, measuring location, criteria and remarks				
6	Short circuit in wiring harness	1. Turn starting switch to OFF position. 2. Disconnect connectors ECM J1 and INJECTOR CYL 5 & 6, and connect T-adapters to female side of ECM J1.  ★ Check by using multimeter in continuity mode.				
		<table border="1" style="width: 100%;"> <tr> <td style="width: 30%;">Continuity</td> <td>Between ECM J1 (female) (45) and each pin other than pin (45)</td> <td>No continuity (No sound is heard)</td> </tr> <tr> <td></td> <td>Between ECM J1 (female) (55) and each pin other than pin (55)</td> <td>No continuity (No sound is heard)</td> </tr> </table>	Continuity	Between ECM J1 (female) (45) and each pin other than pin (45)	No continuity (No sound is heard)	
Continuity	Between ECM J1 (female) (45) and each pin other than pin (45)	No continuity (No sound is heard)				
	Between ECM J1 (female) (55) and each pin other than pin (55)	No continuity (No sound is heard)				
7	Defective injector of other cylinder	If failure codes of other injectors are displayed, perform troubleshooting for them first.				
8	Defective injector harness of other cylinder	If failure codes of other injectors are displayed, perform troubleshooting for them first.				
9	Defective engine controller	If no failure is found by above checks, engine controller is defective. (Since this is an internal defect, troubleshooting cannot be performed.)				

**Circuit diagram related to injector #6**

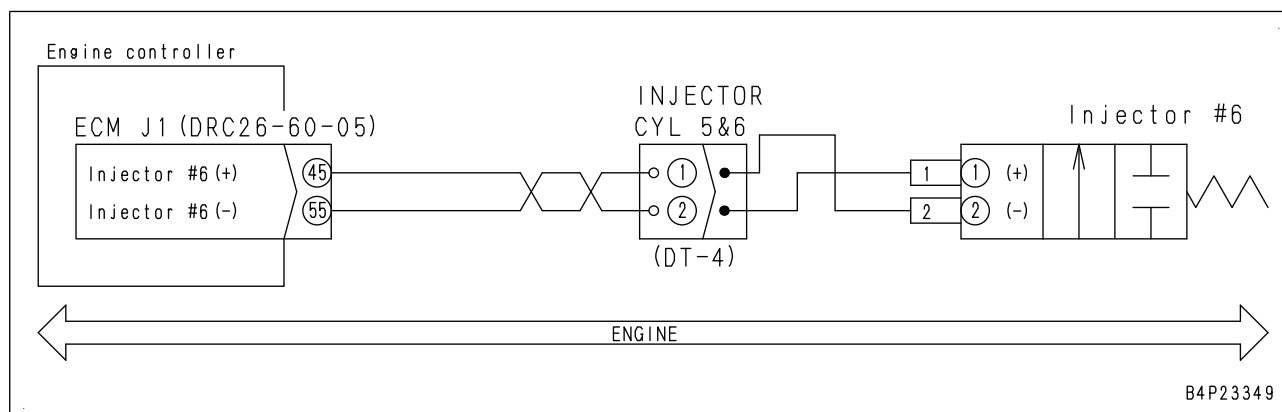

## 40 Troubleshooting

### Troubleshooting by failure code (Display of code)

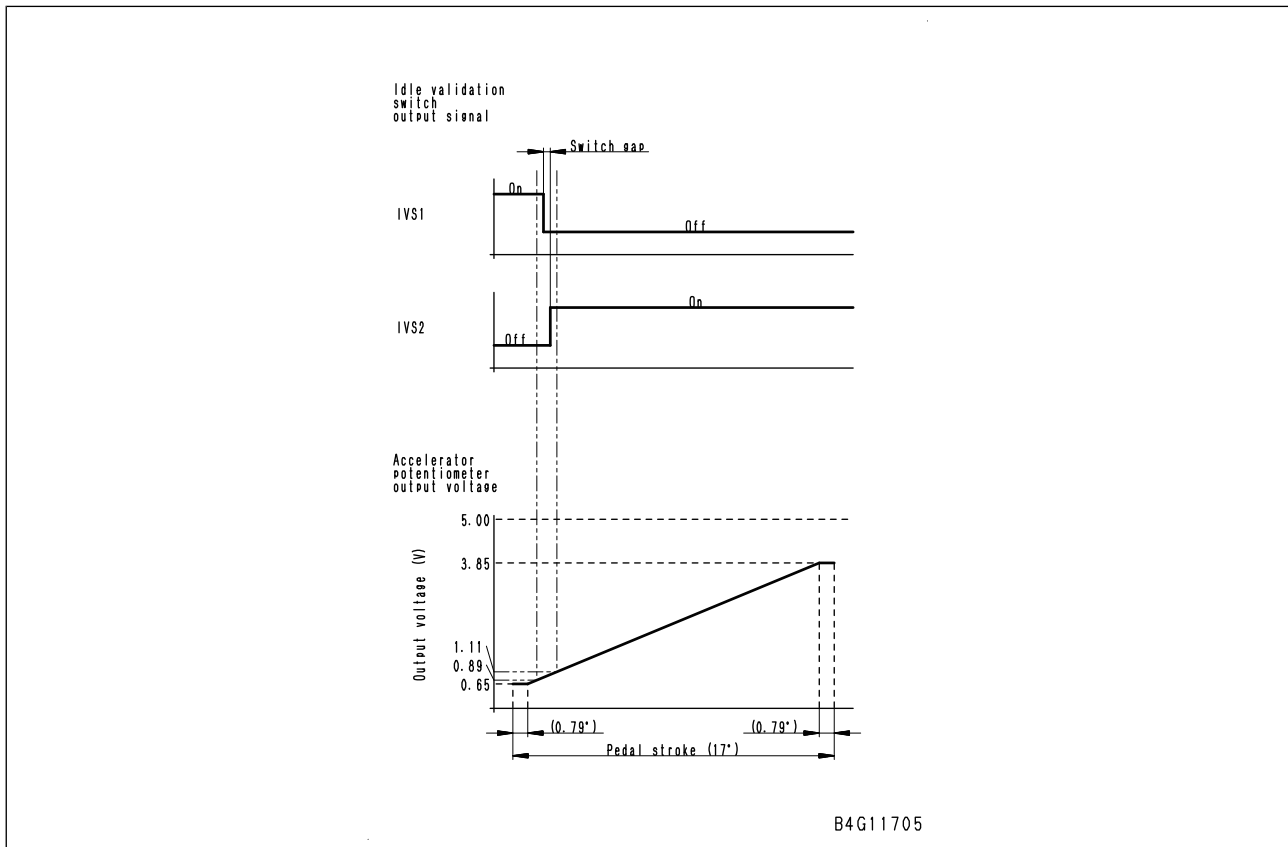

Fig. 1

Pedal stroke: Stroke of accelerator pedal

Output voltage : Output voltage: (pin 2 of connector PD and pin 51 of connector EC3)

IVS1: Signal voltage of idle validation switch 1

IVS2: Signal voltage of idle validation switch 2

Switch gap: Zone where both signals of IVS1 and IVS2 are OFF

**Failure code [CA689] Eng Ne Speed Sensor Error** (WA380\_7-CA689-400-A-Z0-A)

Action level	Failure code	Failure	Engine Ne Speed Sensor Error (Engine controller system)
L01	CA689		
Detail of failure	<ul style="list-style-type: none"> <li>Engine Ne speed sensor signal is abnormal.</li> </ul>		
Action of controller	<ul style="list-style-type: none"> <li>Runs engine by using signals from engine Bkup speed sensor.</li> </ul>		
Problem on machine	<ul style="list-style-type: none"> <li>Running engine stops (when Bkup (CAM) speed sensor is also defective).</li> <li>Stopped engine cannot be started (when Bkup (CAM) speed sensor is also defective).</li> <li>Engine starting performance becomes deteriorated</li> <li>Engine hunts.</li> </ul>		
Related information	<ul style="list-style-type: none"> <li>Method of reproducing failure code: Start engine.</li> <li>Since interior portion of speed sensor is configured with hall sensor and electronic circuit rather than coil, measurements of speed sensor resistance by using multimeter cannot be used to determine whether sensor is normal or not.</li> <li>Since speed sensor output is pulse voltage of 5 V in normal state, multimeter is not usable for measurement.</li> <li>Speed sensor detects passing of slot on speed sensing wheel, which is installed to inner surface on vibration damper, to measure crankshaft speed.</li> </ul>		

No.	Cause	Procedure, measuring location, criteria and remarks			
1	Defective harness connector	1. See descriptions of wiring harness and connectors in "c: Electrical equipment" in "Checks before troubleshooting" of "General information on troubleshooting", and check it. 2. Turn starting switch to ON position.			
		If this failure code disappears, harness connector is defective. ★ If this failure code appears, perform following checks.			
2	Defective Ne speed sensor power supply system	If failure code [CA238] or [CA239] is also displayed, perform troubleshooting for it first.			
3	Breakage or improper installation (loosened) of engine Ne speed sensor	Engine Ne speed sensor may be broken or installed improperly (loosened). Check it.			
4	Defective Ne speed sensor power supply input	1. Turn starting switch to OFF position. 2. Disconnect connector CRANK SENSOR and connect T-adapters to female side. 3. Turn starting switch to ON position.			
		Voltage	Between CRANK SENSOR (female) (1) and (2)	Power supply input	4.75 to 5.25 V
5	Open circuit in wiring harness (wire breakage or defective contact of connector)	1. Turn starting switch to OFF position. 2. Disconnect connectors ECM J1 and CRANK SENSOR and connect T-adapters to each female side.			
		Resistance	★ If no failure is found by check on cause 4, this check is not required. Between ECM J1 (female) (36) and CRANK SENSOR (female) (1)	Max. 10 Ω	
			★ If no failure is found by check on cause 4, this check is not required. Between ECM J1 (female) (37) and CRANK SENSOR (female) (2)	Max. 10 Ω	
		Between ECM J1 (female) (26) and CRANK SENSOR (female) (3)		Max. 10 Ω	

## 40 Troubleshooting

Troubleshooting by failure code (Display of code)

### Failure code [CA1696] Sensor 5 Supply Volt Low Error (WA380\_7-CA1696-400-A-Z0-A)

Action level	Failure code	Failure	Sensor 5 Supply Voltage Low Error (Engine controller system)
L03	CA1696		
Detail of failure	<ul style="list-style-type: none"> <li>Low voltage appears in 5 V power supply circuit for KDPF delta pressure sensor and KDPF outlet pressure sensor.</li> </ul>		
Action of controller	<ul style="list-style-type: none"> <li>Takes it that KDPF outlet pressure sensor is at fixed value (0 kPa{0 kg/cm<sup>2</sup>}) and allows engine to run.</li> <li>Takes it that KDPF delta pressure is at estimated value and allows engine to run (uses delta pressure of 0 kPa in some cases) .</li> <li>Closes EGR valve.</li> <li>Limits engine output and allows engine to run.</li> <li>Stops KDPF regeneration control.</li> </ul>		
Problem on machine	<ul style="list-style-type: none"> <li>Engine output decreases.</li> </ul>		
Related information	<ul style="list-style-type: none"> <li>KDPF delta pressure sensor and KDPF outlet pressure sensor are integrated.</li> <li>Method of reproducing failure code: Turn starting switch to ON position.</li> </ul>		

No.	Cause	Procedure, measuring location, criteria and remarks		
1	Defective harness connector	<ol style="list-style-type: none"> <li>See descriptions of wiring harness and connectors in "c: Electrical equipment" in "Checks before troubleshooting" of "General information on troubleshooting", and check it.</li> <li>Turn starting switch to ON position.</li> </ol>		
		If this failure code disappears, harness connector is defective. ★ If this failure code appears, perform following checks.		
2	Defective KDPF delta pressure (outlet pressure) sensor (internal defect)	<ol style="list-style-type: none"> <li>Turn starting switch to OFF position.</li> <li>Disconnect connector E25.</li> <li>Turn starting switch to ON position.</li> </ol>		
		★ Ignore displayed failure codes other than this code. If this failure code is not displayed, KDPF delta pressure (outlet pressure) sensor is defective.		
3	Ground fault in wiring harness (contact with ground circuit)	<ol style="list-style-type: none"> <li>Turn starting switch to OFF position.</li> <li>Disconnect connectors EC3 and E25, and connect T-adapters to either female side.</li> </ol>		
		Resistance	Between ground and EC3 (female) (52) or E25 (female) (4)	Min. 100 kΩ
4	Short circuit in wiring harness	<ol style="list-style-type: none"> <li>Turn starting switch to OFF position.</li> <li>Disconnect connectors EC3 and E25, and connect T-adapters to female side of EC3.</li> </ol>		
		Resistance	Between EC3 (female) (52) and each pin other than pin (52)	Min. 100 kΩ
5	Defective engine controller	<ol style="list-style-type: none"> <li>Turn starting switch to OFF position.</li> <li>Disconnect connector E25.</li> <li>Insert T-adapters into connector EC3 or connect T-adapters to female side of connector E25.</li> <li>Turn starting switch to ON position.</li> </ol>		
		Voltage	Between EC3 (52) and (43) or between E25 (female) (4) and (1)	4.75 to 5.25 V

**Failure code [CA1993] KDPF Delta Pressure Low Error** (WA380\_7-CA1993-400-A-Z0-A)

Action level	Failure code	Failure	KDPF Delta Pressure Low Error (Engine controller system)
L03	CA1993		
Detail of failure	<ul style="list-style-type: none"> <li>Signal voltage from KDPF differential pressure sensor is below the threshold.</li> </ul>		
Action of controller	<ul style="list-style-type: none"> <li>Closes EGR valve.</li> <li>Limits engine output and allows engine to run.</li> <li>Stops KDPF regeneration control.</li> </ul> <p>★ You can cancel above measure by "turning starting switch to OFF position once, then turning starting switch to ON position" after failure code is generated.</p>		
Problem on machine	<ul style="list-style-type: none"> <li>Engine output decreases.</li> </ul>		
Related information	<p><b>⚠ Since KDPF is heated to 500 °C or above, take care not to get burn injury.</b></p> <ul style="list-style-type: none"> <li>KDPF delta pressure sensor and KDPF outlet pressure sensor are integrated.</li> <li>Signal voltage from KDPF delta pressure sensor can be checked with monitoring function. (Code: 47101(V))</li> <li>Differential voltage sent from KDPF differential pressure sensor can be checked with monitoring function. (Code: 47100 (kPa))</li> <li>The temperature detected by the KDOC inlet temperature sensor can be checked with monitoring function (Code: 47300 (°C))</li> <li>The temperature detected by KDOC outlet temperature sensor can be checked with monitoring function (Code: 47400 (°C))</li> <li>The temperature detected by KDPF outlet temperature sensor can be checked with monitoring function (Code: 47200 (°C))</li> <li>As to procedure for accessing KDPF delta pressure sensor, wiring harness, and tube, see 50 Disassembly and assembly, "Removal and installation of KDPF assembly" and "Disassembly and assembly of KDPF".</li> <li>Engine controller stops approximately 30 seconds after starting switch is turned to OFF position. So when you restart engine, wait one minute minimum before turning starting switch to ON position again.</li> </ul>		
Machine operation for clearing failure code	<ul style="list-style-type: none"> <li>When this failure code appears, perform troubleshooting according to following work flow.</li> </ul> <p>A. Identification of cause and fixing  ↓  B. Machine operation for clearing failure code</p> <p>★ This failure code does not disappear by simply turning starting switch to ON position from OFF position after repair. You must perform machine operation for clearing failure code after fixing trouble.</p> <p>★ In machine operation for clearing failure code, "dummy temperature sensor: 799T-601-4680" is used.</p>		

## 40 Troubleshooting

### Troubleshooting by failure code (Display of code)

No.	Cause	Procedure, measuring location, criteria and remarks	
6	Defective exhaust manifold pressure sensor (internal defect)	1. Turn starting switch to OFF position. 2. Insert T-adapter to connector ECM J2 3. Turn starting switch to ON position.	
		<table border="1"> <tr> <td>Voltage</td> <td>Between EXHAUST PRESSURE (female) (3) and (2)</td> <td>0.2 to 4.7 V</td> </tr> </table>	Voltage
Voltage	Between EXHAUST PRESSURE (female) (3) and (2)	0.2 to 4.7 V	
7	Defective engine controller	If no failure is found by above checks, engine controller is defective. (Since this is an internal defect, troubleshooting cannot be performed.)	

### Circuit diagram related to exhaust manifold pressure sensor

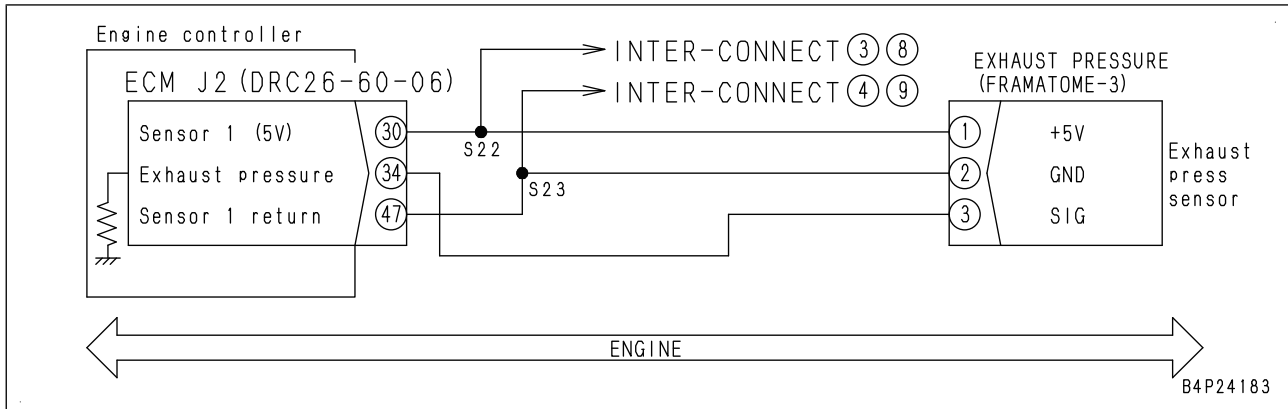

Related information	<ul style="list-style-type: none"> <li>★ Time required for manual stationary regeneration depends on the accumulated soot in KCSF, however, it is estimated as follows. <ul style="list-style-type: none"> <li>• If soot accumulation is level 4: approximately 40 minutes to 1 hour</li> <li>• If soot accumulation is level 5: approximately 1 to 2 hours</li> </ul> </li> <li>★ If the soot sedimentation reaches level 6 or 7, failure code [CA1921] is displayed.</li> <li>★ If the soot sedimentation reaches level 8, failure code [CA1922] is displayed.</li> <li>★ If this failure code is still displayed after several hours have passed after manual stationary regeneration, perform following troubleshooting procedures.</li> <li>★ If another failure code is displayed (including when manual stationary regeneration is in progress), perform troubleshooting for it first. <ul style="list-style-type: none"> <li>• Method of reproducing failure code: Turn starting switch to ON position.</li> </ul> </li> </ul>
---------------------	--

No.	Cause	Procedure, measuring location, criteria and remarks
1	Increase of soot accumulation due to "Regeneration Disable"	<ol style="list-style-type: none"> <li>1. Check if the regeneration stop button is pressed down from the machine monitor. If the regeneration stop button is pressed down, release it.</li> <li>2. Turn starting switch to the ON position.</li> <li>3. Make sure that machine is in safe condition.</li> <li>4. Start the engine, and perform the manual stationary regeneration from user mode.</li> </ol> <ul style="list-style-type: none"> <li>★ When the manual stationary regeneration is finished correctly, the repair is completed.</li> <li>★ If the regeneration does not complete within 3 hours, proceed to checks on cause 2 and after.</li> </ul>
2	Defective KDOC inlet temperature sensor	<ul style="list-style-type: none"> <li>• If there is a significant difference between KDOC inlet temperature and KDOC outlet temperature when KDPF is completely cool or engine running at idle (not regenerating), replace KDOC inlet temperature sensor.</li> </ul>
3	Defective VGT	<p>VGT may have mechanical failure. Check it.</p> <p>If values of KDOC inlet temperature: approximately 250°C or below and VGT solenoid current: approximately 1000 mA remain unchanged after performing regeneration for service, VGT is defective.</p> <p>(The time required for manual stationary regeneration depends on the accumulated soot level. See related information.)</p>
4	Defective KDPF (KDOC, KCSF)	<ol style="list-style-type: none"> <li>1. Perform troubleshooting for "S-22" in S mode.</li> </ol>
5	Unusual exhaust gas color	<ul style="list-style-type: none"> <li>★ If failure code [CA2639] is displayed after the manual stationary regeneration is completed, perform the following.</li> <li>★ For check of the exhaust gas color, see "30 Testing and adjusting", "Testing exhaust gas color".</li> <li>★ When checking the exhaust gas color, perform the "Regeneration Disable" from the machine monitor.</li> <li>1. Rapidly accelerate engine from low idle to high idle 2 times, and then keep engine running at high idle for 5 seconds. <ul style="list-style-type: none"> <li>• If excessive black smoke is exhausted when accelerating engine or running it at high idle, troubleshoot for "S-9 KDPF gets clogged in a short time".</li> </ul> </li> <li>★ When black smoke particles are exhausted during engine acceleration, if it disappears with engine at high idle, the exhaust gas color is judged as normal.</li> <li>★ Check that no failure code appears.</li> <li>★ When you finish the check of the exhaust gas color, release "Regeneration Disable".</li> </ul>

# 40 Troubleshooting

## Troubleshooting by failure code (Display of code)

### Circuit diagram related to KDOC and KDPF temperature sensors

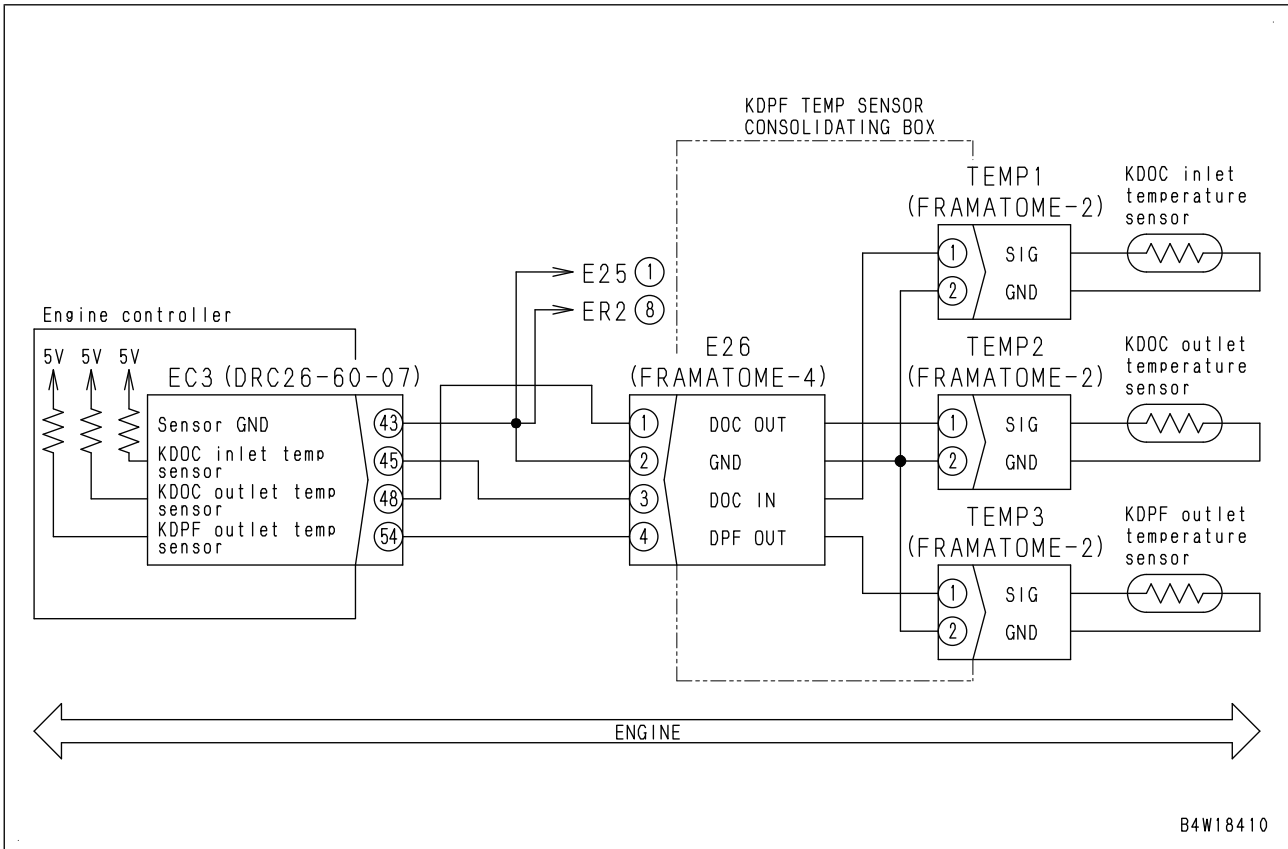

**Failure code [CA3316] KDOC Outlet Temp Sens Low Error** (WA380\_7-CA3316-400-A-Z0-

A)

Action level	Failure code	Failure	KDOC Outlet Temperature Sensor Low Error (Engine controller system)
L03	CA3316		
Detail of failure	<ul style="list-style-type: none"> <li>Low voltage appears in KDOC outlet temperature sensor circuit.</li> </ul>		
Action of controller	<ul style="list-style-type: none"> <li>Uses KDOC inlet temperature for KDOC outlet temperature to run engine. (If failure is detected in KDOC inlet temperature sensor too, controller takes it that KDOC outlet temperature is at default value (250°C) and allows engine to run.)</li> <li>Closes EGR valve.</li> <li>Limits engine output and allows engine to run.</li> <li>Stops KDPF regeneration control.</li> </ul>		
Problem on machine	<ul style="list-style-type: none"> <li>Engine output decreases.</li> </ul>		
Related information	<p><b>⚠ Since temperature of KDPF and KDOC becomes 500 °C or higher, take care not to get burn injury.</b></p> <ul style="list-style-type: none"> <li>Signal voltage from KDOC inlet temperature sensor can be checked with monitoring function. (Code: 47301(V))</li> <li>Temperature sensed by KDOC inlet temperature sensor can be checked with monitoring function. (Code: 47300 (°C))</li> <li>Signal voltage from KDOC outlet temperature sensor can be checked with monitoring function. (Code: 47401(V))</li> <li>Temperature sensed by KDOC outlet temperature sensor can be checked with monitoring function. (Code: 47400 (°C))</li> <li>Signal voltage from KDPF outlet temperature sensor can be checked with monitoring function. (Code: 47201(V))</li> <li>Temperature sensed by KDPF outlet temperature sensor can be checked with monitoring function. (Code: 47200 (°C))</li> <li>If sensor connector is disconnected or open circuit occurs, this failure code does not appear but failure code [CA3317] for "High Error" appears.</li> <li>KDOC inlet temperature sensor connector label "TEMP1" expressed in black embossed letters is seen on KDPF temperature sensor consolidating box (KDOC outlet temperature sensor connector label "TEMP2" and KDPF outlet sensor connector label "TEMP3" are shown similarly to "TEMP1").</li> <li>Method of reproducing failure code: Turn starting switch to ON position.</li> </ul> <p>&lt;How to clear failure code&gt;</p> <p>To avoid error due to improper operation, start and run engine at idle for 1 minute. If this failure code is cleared, repair is complete.</p>		

No.	Cause	Procedure, measuring location, criteria and remarks
1	Defective harness connector	1. See descriptions of wiring harness and connectors in "c: Electrical equipment" in "Checks before troubleshooting" of "General information on troubleshooting", and check it. 2. Turn starting switch to ON position.
		If this failure code disappears, harness connector is defective. ★ If this failure code appears, perform following checks.

## 40 Troubleshooting

### Troubleshooting by failure code (Display of code)

## Failure code [CA3419] Mass Air Flow Sensor Sup Volt High Error (WA380\_7-

CA3419-400-A-Z0-A)

Action level	Failure code	Failure	Mass Air Flow Sensor Supply Voltage High Error (Engine controller system)
L03	CA3419		
Detail of failure	<ul style="list-style-type: none"> <li>High voltage appears in power supply (12 V) circuit of mass air flow sensor.</li> </ul>		
Action of controller	<ul style="list-style-type: none"> <li>★ If signal voltage of mass air flow sensor becomes abnormal, controller takes following measures that are similar to those for failure codes [CA356] and [CA357].</li> <li>Takes it that mass air flow is at fixed value (10 kg/min) and allows engine to run.</li> <li>Closes EGR valve.</li> <li>Limits engine output and allows engine to run.</li> <li>Stops KDPF regeneration control.</li> </ul>		
Problem on machine	<ul style="list-style-type: none"> <li>Engine output decreases.</li> </ul>		
Related information	<ul style="list-style-type: none"> <li>Method of reproducing failure code: Turn starting switch to ON position.</li> </ul>		

No.	Cause	Procedure, measuring location, criteria and remarks		
1	Defective harness connector	1. See descriptions of wiring harness and connectors in "c: Electrical equipment" in "Checks before troubleshooting" of "General information on troubleshooting", and check it. 2. Turn starting switch to ON position.		
		If this failure code disappears, harness connector is defective. ★ If this failure code appears, perform following checks.		
2	Defective mass air flow sensor (internal defect)	1. Turn starting switch to OFF position. 2. Disconnect connector R93A. 3. Turn starting switch to ON position.		
		If this failure code does not appear, MAF sensor is defective. ★ Other failure codes (many codes) are also displayed. They are generated because of disconnection of connector. Ignore failure codes other than this code.		
3	Defective wiring harness	1. Turn starting switch to OFF position. 2. Disconnect connector ECM J1. 3. Turn starting switch to ON position.		
		If this failure code does not appear, wiring harness is defective. ★ Other failure codes (many codes) are also displayed. They are generated because of disconnection of connector. Ignore failure codes other than this code.		
4	Defective engine controller	1. Turn starting switch to OFF position. 2. Disconnect connector ECM J1 and connect T-adapters to male side. 3. Turn starting switch to ON position.		
		Voltage	Between ECM J1 (male) (21) and (22)	Approx. 12 V
		If no failure is found by above checks, engine controller is defective. (Since this is an internal defect, troubleshooting cannot be performed.)		

CLICK HERE TO **DOWNLOAD** THE COMPLETE MANUAL

- Thank you very much for reading the preview of the manual.
- You can download the complete manual from: [www.heydownloads.com](http://www.heydownloads.com) by clicking the link below



- Please note: If there is no response to CLICKING the link, please download this PDF first and then click on it.

CLICK HERE TO **DOWNLOAD** THE COMPLETE MANUAL

**Failure code [D191KY] Hot Short of Neutral Output Relay** (WA380\_7-D191KY-400-A-Z0-A)

Action level	Failure code	Failure	Hot Short of Neutral Output Relay (Transmission controller system)
L03	D191KY		
Detail of failure	<ul style="list-style-type: none"> <li>When controller does not drive primary circuit (coil) of neutral safety relay, current flows through circuit.</li> </ul>		
Action of controller	<ul style="list-style-type: none"> <li>None in particular.</li> <li>Even if cause of failure disappears, machine does not become normal until starting switch is turned to OFF position.</li> </ul>		
Problem on machine	<ul style="list-style-type: none"> <li>Engine can start even if shift lever or directional selector (FNR) switch is except N (NEUTRAL).</li> </ul>		
Related information	<ul style="list-style-type: none"> <li>Output signal to primary circuit (coil side) of neutral safety relay can be checked with monitoring function. (Code 40909: Neutral safety relay)</li> <li>Method of reproducing failure code: Turn starting switch to ON position and move directional lever to N (NEUTRAL).</li> <li>This failure code indicates failure on primary circuit (coil side) of neutral safety relay, but not on secondary circuit (contact side).</li> </ul>		

No.	Cause	Procedure, measuring location, criteria and remarks			
1	Defective neutral safety relay	1. Turn starting switch to OFF position. 2. Disconnect connector L116 and connect T-adapters to male side.			
		Resistance	Between connector L116 (male) (1) and (2)	200 to 400 Ω	
2	Hot short circuit in wiring harness (contact with 24 V circuit)	1. Turn starting switch to OFF position. 2. Disconnect connector D12 and connect T-adapters to female side. 3. Turn starting switch to ON position. 4. Move directional lever to position other than N (NEUTRAL).			
		Voltage	Between D12 (female) (1) and ground	Max. 4.5 V	
			Between D12 (female) (2) and ground	Max. 4.5 V	
3	Defective transmission controller	If no failure is not found in above checks, transmission controller is defective. <ul style="list-style-type: none"> <li>Reference</li> <li>1. Turn starting switch to OFF position.</li> <li>2. Insert T-adapters into connector L63.</li> <li>3. Turn starting switch to ON position.</li> <li>4. Move directional lever to perform troubleshooting.</li> </ul>			
		Voltage	Between L63 (female) (8) and ground	Directional lever: N (NEUTRAL)	20 to 30 V
				Directional lever: Other than N (NEUTRAL)	Max. 4.5 V

## 40 Troubleshooting

Troubleshooting by failure code (Display of code)

### Failure code [D862KA] GPS Antenna Open Circuit (WA380\_7-D862KA-400-A-Z0-A)

Action level	Failure code	Failure	GPS Antenna Open Circuit (KOMTRAX system)
—	D862KA		
Detail of failure	<ul style="list-style-type: none"> <li>GPS module detects open circuit in GPS antenna circuit.</li> </ul>		
Action of machine monitor	<ul style="list-style-type: none"> <li>None in particular.</li> <li>If cause of failure disappears, machine becomes normal by itself.</li> </ul>		
Problem on machine	<ul style="list-style-type: none"> <li>GPS positioning system does not work.</li> </ul>		
Related information	<ul style="list-style-type: none"> <li>Method of reproducing failure code: Turn starting switch to ON position.</li> </ul>		

No.	Cause	Procedure, measuring location, criteria and remarks
1	Defective GPS antenna or antenna cable	GPS antenna may be defective, or antenna cable may have open or short circuit, or poor contact at terminal area (A).

#### Figure of structure

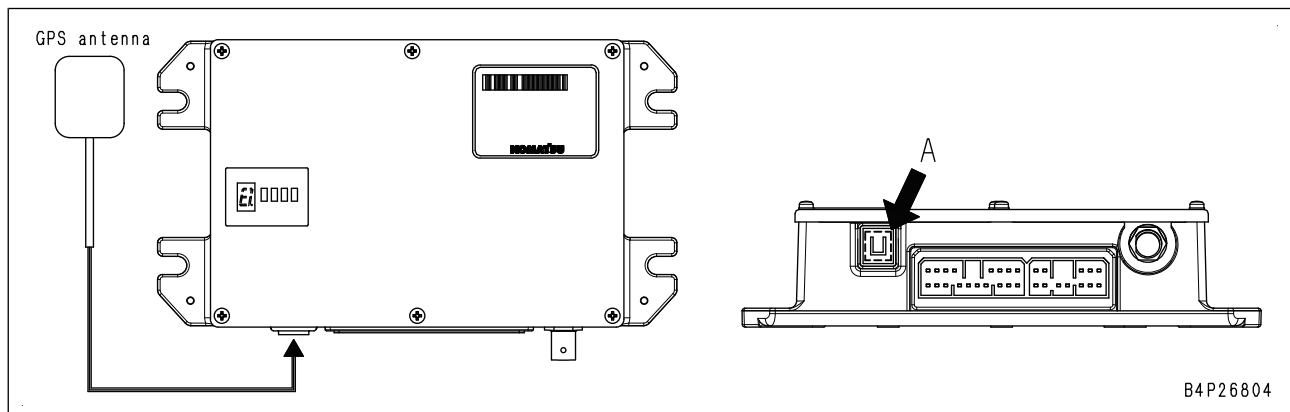

Circuit diagram related to power supply of transmission controller

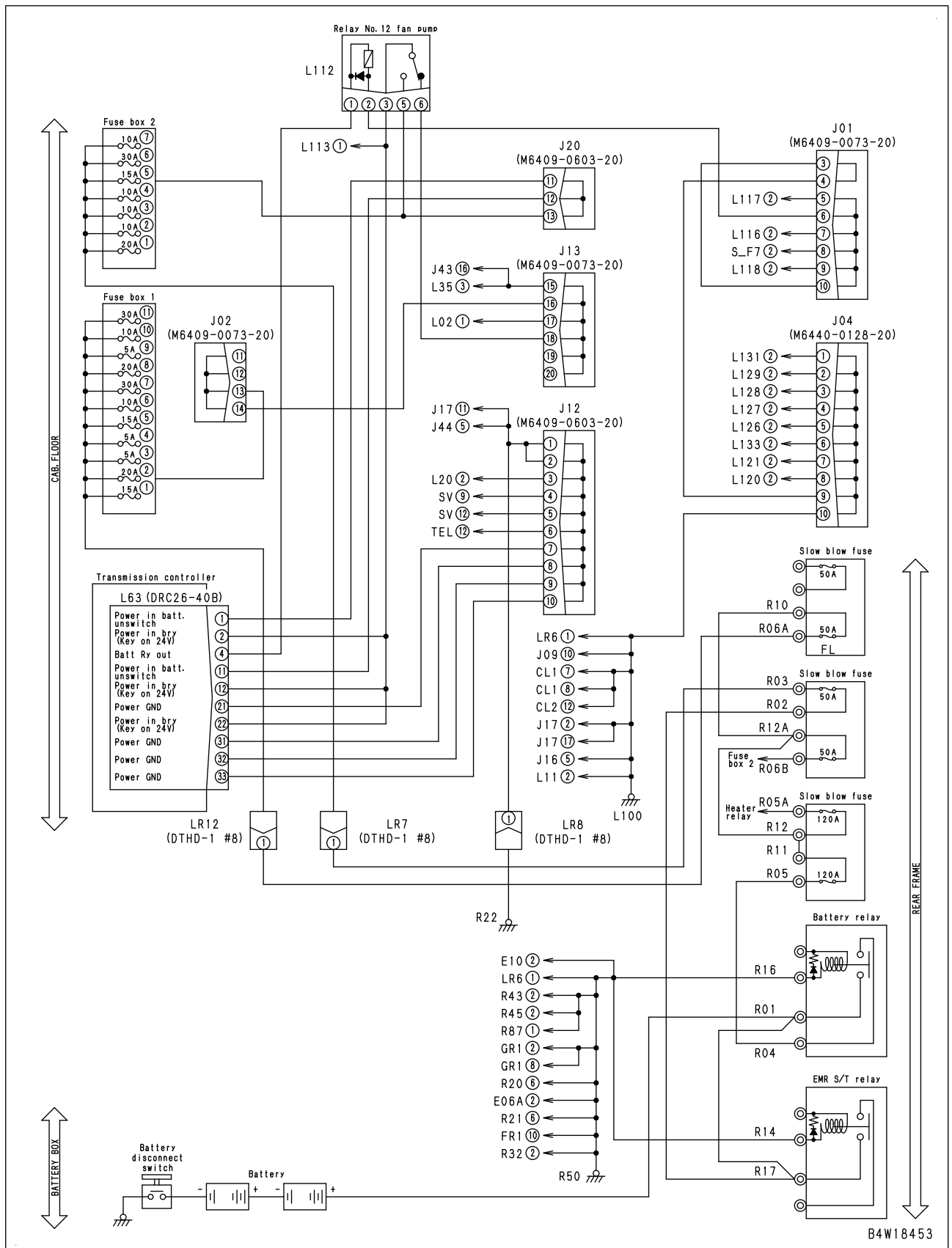

## 40 Troubleshooting

### Troubleshooting by failure code (Display of code)

No.	Cause	Procedure, measuring location, criteria and remarks	
7	Ground fault in wiring harness (contact with ground circuit)	<p>★ If no failure (open circuit) is found by check on cause 5, measure resistance at any one place in each case.</p> <ol style="list-style-type: none"> <li>Turn starting switch to OFF position, and set battery disconnect switch to OFF position.</li> <li>Disconnect related connectors and connect T-adapters to female side of connector at which measurement is performed.</li> </ol>	
		Resistance	<p>Between ground and any of MDM3 (female) (3), L62 (female) (32), L80A (female) (10), AL1 (female) (4), EC3 (female) (17), or L72 (female) (32)</p> <p>Min. 1 MΩ</p>
		Resistance	<p>Between ground and any of MDM3 (female) (8), L62 (female) (22), L80A (female) (11), AL1 (female) (6), EC3 (female) (18), or L72 (female) (22)</p> <p>Min. 1 MΩ</p>
8	Open circuit or hot short circuit in wiring harness (contact with 24 V circuit)	<p>★ If no failure (open circuit) is found by check on cause 5, measure voltage at any one place in each case.</p> <ol style="list-style-type: none"> <li>Turn starting switch to OFF position, and set battery disconnect switch to OFF position.</li> <li>Disconnect connector at which measurement is performed and insert T-adapters into connector.</li> <li>Set battery disconnect switch to ON position.</li> <li>Turn starting switch to ON position.</li> </ol> <p>★ Voltage of CAN H and CAN L is <math>2.5 \pm 1</math> V including during communication, so regard wiring harness as normal if measure voltage is 1 to 4 V.</p>	
		Voltage	<p>Between ground and any of MDM3 (female) (3), L62 (female) (32), L80A (female) (10), AL1 (female) (4), EC3 (female) (17), or L72 (female) (32)</p> <p>1 to 4 V</p>
		Voltage	<p>Between ground and any of MDM3 (female) (8), L62 (female) (22), L80A (female) (11), AL1 (female) (6), EC3 (female) (18), or L72 (female) (22)</p> <p>1 to 4 V</p>
9	Defective engine controller, work equipment controller, transmission controller, air conditioner controller, machine monitor (meter unit), or KOMTRAX terminal	<ul style="list-style-type: none"> <li>When all of six failure codes [D8AQKR], [DAQQKR], [DAZQKR], [DB2QKR], [DB9QKR], and [DSJ0KR] are displayed simultaneously</li> </ul> <p>★ To identify defective controller, repeat following steps 1. to 3. to disconnect controllers one by one from CAN communication line .</p> <ol style="list-style-type: none"> <li>Turn starting switch to OFF position, and set battery disconnect switch to OFF position.</li> <li>Disconnect each CAN communication connector one by one in order engine controller connector EC3, work equipment controller connector L72, transmission controller connector L62, air conditioner controller connector AL1, KOMTRAX terminal connector L80A, and machine monitor (meter unit) connector MDM3.</li> <li>Set battery disconnect switch to ON position, turn starting switch to ON position, then perform troubleshooting.</li> <li>Return to step 1 to check next connector.</li> </ol>	
		Has the number of displayed failure codes decreased from six?	If YES, disconnected controller is defective.
10	Defective engine controller	If no failure is found by above checks, engine controller is defective. (Since this is an internal defect, troubleshooting cannot be performed.)	
11	Defective monitor controller	If no failure is found by above checks, monitor controller is defective. (Since this is an internal defect, troubleshooting cannot be performed.)	

Circuit diagram related to 5 V sensor power supply (Multi-function mono-lever specification)

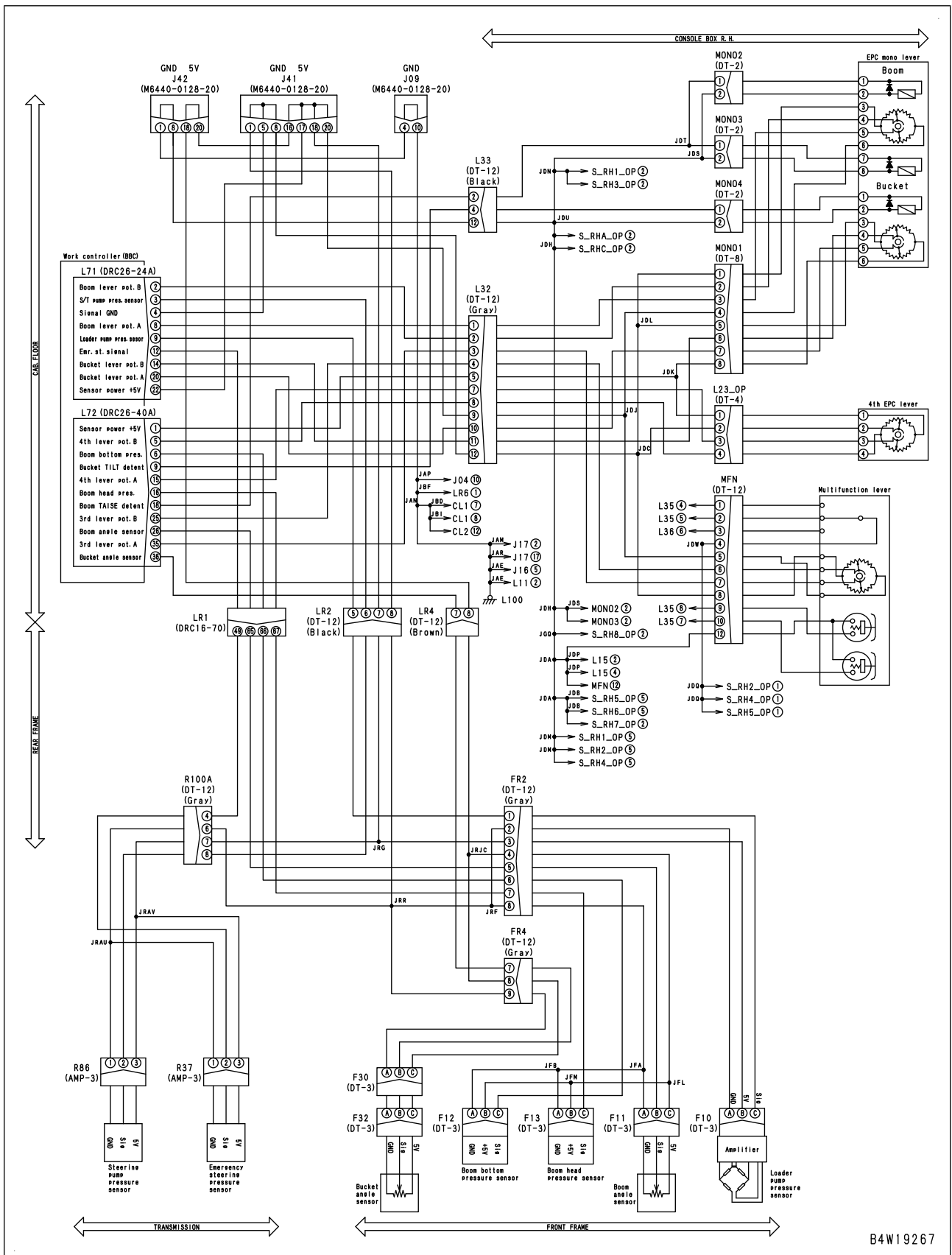

B4W19267

# 40 Troubleshooting

## Troubleshooting by failure code (Display of code)

Circuit diagram related to remote positioner set switch (2-lever specification or 3-lever specification)

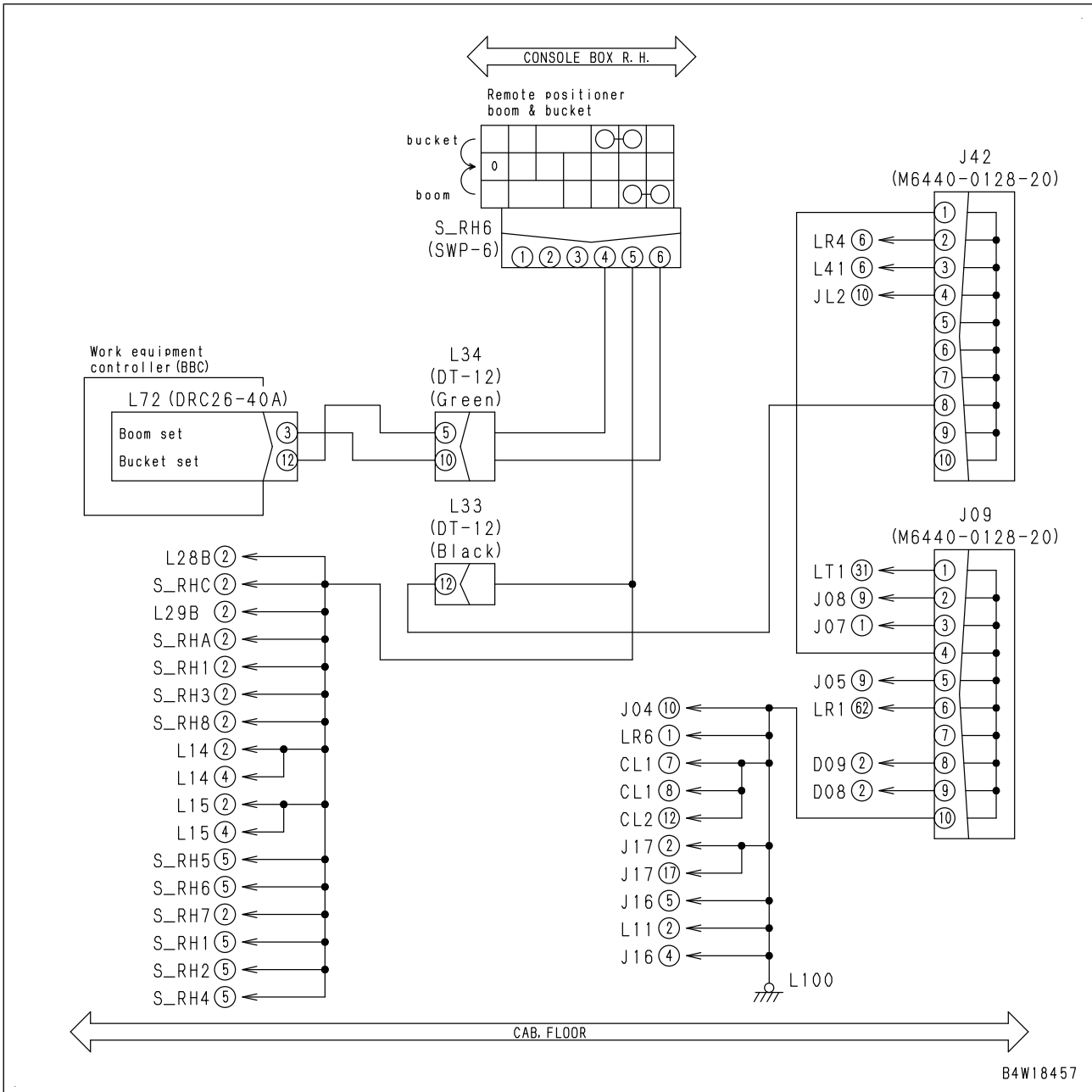

B4W18457

**Multi-function mono-lever specification**

No.	Cause	Procedure, measuring location, criteria and remarks			
1	Defective transmission auto/manual shift mode selector switch (internal defect)	1. Turn starting switch OFF. 2. Disconnect connector S_RH3_OP and connect T-adapter to male side.			
		Resistance	Between S_RH3_OP (male) (4) and (5)	Shift mode: Manual shift	Max. 1 Ω
				Shift mode: Auto shift (L)	Min. 1 MΩ
				Shift mode: Auto shift (H)	Min. 1 MΩ
		Resistance	Between S_RH3_OP (male) (5) and (6)	Shift mode: Manual shift	Min. 1 MΩ
				Shift mode: Auto shift (L)	Min. 1 MΩ
Shift mode: Auto shift (H)	Max. 1 Ω				
2	Hot short circuit in wiring harness (contact with 24 V harness)	1. Turn starting switch OFF. 2. Disconnect connector S_RH3_OP and connect T-adapter to female side. 3. Turn starting switch ON.			
		Voltage	Between S_RH3_OP (female) (6) and ground	Max. 1 V	
			Between S_RH3_OP (female) (4) and ground	Max. 1 V	
3	Defective transmission controller	1. Turn starting switch OFF. 2. Insert T-adapter into connector L61. 3. Turn starting switch ON.			
		Voltage	Between L61 (18) and ground	Shift mode: Manual shift	20 to 30 V
				Shift mode: Auto shift (L)	Max. 1 V
				Shift mode: Auto shift (H)	Max. 1 V
		Voltage	Between L61 (24) and ground	Shift mode: Manual shift	Max. 1 V
				Shift mode: Auto shift (L)	Max. 1 V
Shift mode: Auto shift (H)	20 to 30 V				

## 40 Troubleshooting

### Troubleshooting by failure code (Display of code)

## Failure code [DGF1KA] Disconnection of T/M Oil Temp. Sensor (WA380\_7-

DGF1KA-400-A-Z0-A)

Action level	Failure code	Failure	Disconnection of Transmission Oil Temperature Sensor (Transmission controller system)
L01	DGF1KA		
Detail of failure	<ul style="list-style-type: none"> <li>Due to open circuit in transmission oil temperature sensor signal system, transmission oil temperature signal is higher than normal range (Transmission oil temperature sensor signal voltage: Min. 4.56 V (Max. 15°C)), and torque converter oil temperature sensor signal voltage: Max. 3.7 V (Min. 55°C).</li> </ul>		
Action of controller	<ul style="list-style-type: none"> <li>Cannot determine transmission oil temperature correctly.</li> <li>If cause of failure disappears, machine becomes normal by itself.</li> </ul>		
Problem on machine	<ul style="list-style-type: none"> <li>Gear shift shock may occur.</li> </ul>		
Related information	<ul style="list-style-type: none"> <li>Input voltage from transmission oil temperature sensor can be checked with monitoring function. (Code: 32501 T/M Oil Temp. Sensor Volt)</li> <li>Oil temperature sensed by transmission oil temperature sensor can be checked with monitoring function. (Code: 32500 T/M Oil Temperature)</li> <li>Input voltage from torque converter oil temperature sensor can be checked with monitoring function. (Code: 30101 T/C Oil Temp. Sensor Volt)</li> <li>Oil temperature sensed by torque converter oil temperature sensor can be checked with monitoring function. (Code: 30100: T/C Oil Temperature)</li> <li>Method of reproducing failure code: Turn starting switch to ON position.</li> </ul>		

No.	Cause	Procedure, measuring location, criteria and remarks			
1	Defective transmission oil temperature sensor	1. Turn starting switch to OFF position. 2. Disconnect connector TM.T and connect T-adapter to male side.			
		Resistance	Between TM.T (male) (1) and (2)	Transmission oil temperature: 25°C (Normal temperature)	35 to 50 kΩ *
				Transmission oil temperature: 100°C	3.1 to 4.5 kΩ *
2	Open circuit, short circuit, ground fault, hot short circuit of wiring harness, or defective transmission controller	1. Turn starting switch to OFF position. 2. Disconnect connector TM.T and connect T-adapter to female side. 3. Turn starting switch to ON position. ★ Voltage of approx. 5 V is applied to temperature sensor signal circuits through resistor in transmission controller. ★ Shake the wiring harness by hand while measuring the voltage. If the voltage drops to approximately 0 V during shaking, circuit is open around this point.			
		Voltage	Between TM.T (female) (1) and (2)	Approx. 5 V	
3	Open or short circuit in wiring harness	★ If no failure is found by check on cause 2, this check is not required. 1. Turn starting switch to OFF position. 2. Disconnect connector L61, and connect T-adapters to female side. ★ Voltage of approx. 5 V is applied to temperature sensor signal circuits through resistor in transmission controller.			
		Resistance	Between L61 (female) (9) and (4)	Transmission oil temperature: 25°C (Normal temperature)	35 to 50 kΩ
				Transmission oil temperature: 100°C	3.1 to 4.5 kΩ

## Failure code [DHT1KX] Out of Range of T/M Cut Off Press. Sensor (WA380\_7-

DHT1KX-400-A-Z0-A)

Action level	Failure code	Failure	Out of Range of Transmission Cut Off Pressure Sensor (Transmission controller system)
L01	DHT1KX		
Detail of failure	<ul style="list-style-type: none"> <li>Due to open circuit or ground fault in transmission cut-off pressure sensor system, transmission cut-off pressure signal voltage is lower than the normal range. (Transmission cut-off pressure sensor signal voltage: Max. 0.3 V)</li> </ul>		
Action of controller	<ul style="list-style-type: none"> <li>Turns off transmission cut-off function.</li> <li>Disables change of transmission cut-off setting.</li> <li>If cause of failure in transmission cut-off function disappears, machine becomes normal by itself.</li> </ul>		
Problem on machine	<ul style="list-style-type: none"> <li>Transmission cut-off indicator goes out.</li> <li>Transmission cut-off function does not work.</li> </ul>		
Related information	<ul style="list-style-type: none"> <li>Input voltage from transmission cut-off pressure sensor can be checked with monitoring function. (Code: 41202 Brake Oil Press Sensor Volt)</li> <li>Oil pressure sensed by transmission cut-off pressure sensor can be checked with monitoring function. (Code: 41201. Brake Oil Pressure)</li> <li>Method of reproducing failure code: Turn starting switch ON and turn transmission cut-off switch ON.</li> </ul>		

No.	Cause	Procedure, measuring location, criteria and remarks			
1	Defective power supply system of transmission cut-off pressure sensor	<ul style="list-style-type: none"> <li>★ When failure code [DBE6KX] is displayed, troubleshoot for it first.</li> <li>1. Turn starting switch OFF.</li> <li>2. Disconnect connector R73 and connect T-adaptor to female side.</li> <li>3. Turn starting switch ON.</li> </ul>			
		Voltage	Between R73 (female) (B) and (A)	Power supply input	20 to 30 V
2	Defective transmission cut-off pressure sensor (internal open or short circuit)	<ul style="list-style-type: none"> <li>★ Replace sensor and see if failure code disappears.</li> <li>1. Turn starting switch OFF.</li> <li>2. Insert T-adaptor into connector R73.</li> <li>3. Start engine.</li> <li>4. Turn transmission cut-off switch ON.</li> </ul>			
		Voltage	Between R73 (C) and (A)	When brake is released	0.9 to 1.1 V
				When brake pedal is depressed (both right and left)	1.1 to 5.1 V
				Constant	0.9 to 5.1 V
Sensor voltage is measured with wiring harness connected. Accordingly, if voltage is abnormal, check harness for failure, and then determine whether sensor is defective or not.					
3	Open circuit in wiring harness (wire breakage or defective contact of connector)	<ul style="list-style-type: none"> <li>1. Turn starting switch OFF.</li> <li>2. Disconnect connectors L61 and R73, and connect T-adaptors to each female side.</li> <li>★ Open circuit of 5 V circuit</li> </ul>			
		Resistance	Between L61 (female) (13) and R73 (female) (C)	Max. 1 Ω	
			Between L61 (female) (16) and R73 (female) (B)	Max. 1 Ω	
			Between L61 (female) (4) and R73 (female) (A)	Max. 1 Ω	

## 40 Troubleshooting

### Troubleshooting by failure code (Display of code)

#### Failure code [DK55L5] Failure of FNR Lever Potentio (WA380\_7-DK55L5-400-A-Z0-A)

Action level	Failure code	Failure	Failure of FNR Lever Potentiometer (Transmission controller system)
L01	DK55L5		
Detail of failure	<ul style="list-style-type: none"> <li>Input analog signal from directional (FNR) lever is impossible relative to input signal (ON/OFF) from directional (FNR) lever switch where devices are normal.</li> <li>This failure code is displayed under following conditions when short circuit to power supply line not detected for directional (FNR) lever switch. (In any case of [A], [B], and [C])</li> </ul> <p>[A]</p> <ol style="list-style-type: none"> <li>directional (FNR) lever switch recognizes that directional (FNR) lever is in F (Forward) position.</li> <li>directional (FNR) lever analog signal voltage is equal to or higher than 2.2 V.</li> <li>Neither of open circuit and ground fault is detected in analog signal system of directional (FNR) lever.</li> </ol> <p>[B]</p> <ol style="list-style-type: none"> <li>directional (FNR) lever switch recognizes that directional (FNR) lever is in R (Reverse) position.</li> <li>directional (FNR) lever analog signal voltage is higher than 2.8 V.</li> <li>Short circuit to power supply line is not detected for directional (FNR) lever analog signal system.</li> </ol> <p>[C]</p> <ol style="list-style-type: none"> <li>directional (FNR) lever switch recognizes that directional (FNR) lever is in N (Neutral) position.</li> <li>Analog signal system of directional (FNR) lever recognizes that directional (FNR) lever is in F (Forward) or R (Reverse) position.</li> </ol>		
Action of controller	<ul style="list-style-type: none"> <li>Takes it that lever position to be determined from analog signal is N (Neutral).</li> <li>Even if cause of failure disappears, machine does not become normal until starting switch is turned to OFF position.</li> </ul>		
Problem on machine	<ul style="list-style-type: none"> <li>No particular problem occurs, as long as directional (FNR) lever switch is normal.</li> </ul>		
Related information	<ul style="list-style-type: none"> <li>Analog signal input voltage from lever can be checked with monitoring function. (Code: 91105 Shift lever Volt)</li> <li>Input signal (ON/OFF) from directional (FNR) lever switch can be checked with monitoring function. (Code: 02211 Main directional (FNR) Signal F, Main directional (FNR) Signal N, Main directional (FNR) Signal R).</li> <li>Method of reproducing failure code: Turn starting switch to ON position.</li> </ul>		
No.	Cause	Procedure, measuring location, criteria and remarks	
1	Defective directional (FNR) lever	directional (FNR) lever may be defective. (Since this is an internal defect, troubleshooting cannot be performed.)	

No.	Cause	Procedure, measuring location, criteria and remarks			
3	Open circuit in wiring harness (wire breakage or defective contact of connector)	1. Turn starting switch to OFF position. 2. Disconnect connectors L71 and MONO1, and connect T-adapters to each female side.			
		Resistance	★ If power supply voltage in check on cause 1 is normal, this check is not required. Between L71 (female) (22) and MONO1 (female) (4)	Max. 1 Ω	
			★ If power supply voltage in check on cause 1 is normal, this check is not required. Between L71 (female) (4) and MONO1 (female) (1)	Max. 1 Ω	
		Between L71 (female) (2) and MONO1 (female) (2)	Max. 1 Ω		
4	Ground fault in wiring harness (contact with ground circuit)	★ If no failure is found by check on cause 2, this check is not required. 1. Turn starting switch to OFF position. 2. Disconnect connectors L71 and MONO1, and connect T-adapters to either female side.			
		Resistance	Between ground and L71 (female) (2) or MONO1 (female) (2)	Min. 1 MΩ	
5	Defective work equipment controller	If no failure is found by above checks, work equipment controller is defective. • Reference 1. Turn starting switch to OFF position. 2. Insert T-adapters into connector L71. 3. Set work equipment lock switch to LOCK position. 4. Turn starting switch to ON position. 5. Operate mono-lever to perform troubleshooting.			
		Voltage	Between L71 (22) and (4)	Always	5.0 to 5.2 V
			Between L71 (2) and (4)	Mono-lever: NEUTRAL	2.40 to 2.60 V
				Mono-lever: Boom RAISE (to short of detent position)	0.96 to 1.62 V
				Mono-lever: Boom RAISE (at detent position)	0.60 to 1.10 V
				Mono-lever: Boom LOWER (to short of detent position)	3.38 to 4.04 V
Mono-lever: Boom FLOAT	3.90 to 4.40 V				



**Multi-function mono-lever specification**

No.	Cause	Procedure, measuring location, criteria and remarks																							
1	Defective 5 V sensor power supply system	<p>When failure code [DB95KX] is also displayed, perform troubleshooting for it first.</p> <ol style="list-style-type: none"> <li>1. Turn starting switch to OFF position.</li> <li>2. Disconnect connector MFN, and connect T-adapters to female side.</li> <li>3. Turn starting switch to ON position.</li> </ol> <p>★ If measured power supply voltage is unusual, go to check on causes 3 and after.</p> <table border="1" style="width: 100%; border-collapse: collapse;"> <tr> <td style="width: 15%; text-align: center;">Voltage</td> <td style="width: 60%;">Between MFN (female) (5) and (8)</td> <td style="width: 25%; text-align: center;">5.0 to 5.2 V</td> </tr> </table>			Voltage	Between MFN (female) (5) and (8)	5.0 to 5.2 V																		
Voltage	Between MFN (female) (5) and (8)	5.0 to 5.2 V																							
2	Defective 3rd valve (attachment) PCS potentiometer (internal open or short circuit)	<ol style="list-style-type: none"> <li>1. Turn starting switch to OFF position.</li> <li>2. Connect T-adapters to connector MFN.</li> </ol> <table border="1" style="width: 100%; border-collapse: collapse;"> <tr> <td rowspan="4" style="width: 15%; text-align: center;">Resis- tance</td> <td style="width: 45%;">Between MFN (male) (5) and ground</td> <td rowspan="4" style="width: 20%; text-align: center;">Min. 1 MΩ</td> </tr> <tr> <td>Between MFN (male) (8) and ground</td> </tr> <tr> <td>Between MFN (male) (7) and ground</td> </tr> <tr> <td>Between MFN (male) (6) and ground</td> </tr> </table> <ol style="list-style-type: none"> <li>3. Turn starting switch to OFF position.</li> <li>4. Insert T-adapters into connector MFN.</li> <li>5. Set work equipment lock switch to LOCK position.</li> <li>6. Turn starting switch to ON position.</li> <li>7. Operated 3rd valve (attachment) PCS (proportional control switch) to perform troubleshooting.</li> </ol> <table border="1" style="width: 100%; border-collapse: collapse;"> <tr> <td rowspan="6" style="width: 15%; text-align: center;">Voltage</td> <td rowspan="3" style="width: 15%; text-align: center;">Between MFN (7) and (8)</td> <td style="width: 30%;">3rd valve (attachment) PCS: NEUTRAL</td> <td style="width: 30%; text-align: center;">2.40 to 2.60 V</td> </tr> <tr> <td>3rd valve (attachment) PCS: Operated to extend cylinder fully</td> <td style="text-align: center;">3.90 to 4.40 V</td> </tr> <tr> <td>3rd valve (attachment) PCS: Operated to retract cylinder fully</td> <td style="text-align: center;">0.60 to 1.10 V</td> </tr> <tr> <td rowspan="3" style="text-align: center;">Between MFN (6) and (8)</td> <td>3rd valve (attachment) PCS: NEUTRAL</td> <td style="text-align: center;">2.40 to 2.60 V</td> </tr> <tr> <td>3rd valve (attachment) PCS: Operated to extend cylinder fully</td> <td style="text-align: center;">0.60 to 1.10 V</td> </tr> <tr> <td>3rd valve (attachment) PCS: Operated to retract cylinder fully</td> <td style="text-align: center;">3.90 to 4.40 V</td> </tr> </table>			Resis- tance	Between MFN (male) (5) and ground	Min. 1 MΩ	Between MFN (male) (8) and ground	Between MFN (male) (7) and ground	Between MFN (male) (6) and ground	Voltage	Between MFN (7) and (8)	3rd valve (attachment) PCS: NEUTRAL	2.40 to 2.60 V	3rd valve (attachment) PCS: Operated to extend cylinder fully	3.90 to 4.40 V	3rd valve (attachment) PCS: Operated to retract cylinder fully	0.60 to 1.10 V	Between MFN (6) and (8)	3rd valve (attachment) PCS: NEUTRAL	2.40 to 2.60 V	3rd valve (attachment) PCS: Operated to extend cylinder fully	0.60 to 1.10 V	3rd valve (attachment) PCS: Operated to retract cylinder fully	3.90 to 4.40 V
Resis- tance	Between MFN (male) (5) and ground	Min. 1 MΩ																							
	Between MFN (male) (8) and ground																								
	Between MFN (male) (7) and ground																								
	Between MFN (male) (6) and ground																								
Voltage	Between MFN (7) and (8)	3rd valve (attachment) PCS: NEUTRAL	2.40 to 2.60 V																						
		3rd valve (attachment) PCS: Operated to extend cylinder fully	3.90 to 4.40 V																						
		3rd valve (attachment) PCS: Operated to retract cylinder fully	0.60 to 1.10 V																						
	Between MFN (6) and (8)	3rd valve (attachment) PCS: NEUTRAL	2.40 to 2.60 V																						
		3rd valve (attachment) PCS: Operated to extend cylinder fully	0.60 to 1.10 V																						
		3rd valve (attachment) PCS: Operated to retract cylinder fully	3.90 to 4.40 V																						
3	Open circuit in wiring harness (wire breakage or defective contact of connector)	<ol style="list-style-type: none"> <li>1. Turn starting switch to OFF position.</li> <li>2. Disconnect connectors L71, L72, and MFN, and connect T-adapters to each female side.</li> </ol> <table border="1" style="width: 100%; border-collapse: collapse;"> <tr> <td rowspan="4" style="width: 15%; text-align: center;">Resis- tance</td> <td style="width: 55%;">★ If power supply voltage in check on cause 1 is normal, this check is not required. Between L71 (female) (22) and MFN (female) (5)</td> <td style="width: 30%; text-align: center;">Max. 1 Ω</td> </tr> <tr> <td>★ If power supply voltage in check on cause 1 is normal, this check is not required. Between L71 (female) (4) and MFN (female) (8)</td> <td style="text-align: center;">Max. 1 Ω</td> </tr> <tr> <td>Between L72 (female) (35) and MFN (female) (7)</td> <td style="text-align: center;">Max. 1 Ω</td> </tr> <tr> <td>Between L72 (female) (25) and MFN (female) (6)</td> <td style="text-align: center;">Max. 1 Ω</td> </tr> </table>			Resis- tance	★ If power supply voltage in check on cause 1 is normal, this check is not required. Between L71 (female) (22) and MFN (female) (5)	Max. 1 Ω	★ If power supply voltage in check on cause 1 is normal, this check is not required. Between L71 (female) (4) and MFN (female) (8)	Max. 1 Ω	Between L72 (female) (35) and MFN (female) (7)	Max. 1 Ω	Between L72 (female) (25) and MFN (female) (6)	Max. 1 Ω												
Resis- tance	★ If power supply voltage in check on cause 1 is normal, this check is not required. Between L71 (female) (22) and MFN (female) (5)	Max. 1 Ω																							
	★ If power supply voltage in check on cause 1 is normal, this check is not required. Between L71 (female) (4) and MFN (female) (8)	Max. 1 Ω																							
	Between L72 (female) (35) and MFN (female) (7)	Max. 1 Ω																							
	Between L72 (female) (25) and MFN (female) (6)	Max. 1 Ω																							

## 40 Troubleshooting

### Troubleshooting by failure code (Display of code)

No.	Cause	Procedure, measuring location, criteria and remarks			
6	Defective work equipment controller	If no failure is found by above checks, work equipment controller is defective.			
		<ul style="list-style-type: none"> <li>Reference</li> </ul> <ol style="list-style-type: none"> <li>Turn starting switch to OFF position.</li> <li>Insert T-adapters into connectors L71 and L72.</li> <li>Set work equipment lock switch to LOCK position.</li> <li>Turn starting switch to ON position.</li> <li>Operate 4th (attachment) lever to perform troubleshooting.</li> </ol>			
		Voltage	Between L72(1) and L71(4)	Always	5.0 to 5.2 V
			Between L72(15) and L71(4)	4th (attachment) lever: NEUTRAL	2.40 to 2.60 V
				4th (attachment) lever: Operated to extend cylinder fully	3.90 to 4.40 V
				4th (attachment) lever: Operated to retract cylinder fully	0.60 to 1.10 V
			Between L72(5) and L71(4)	4th (attachment) lever: NEUTRAL	2.40 to 2.60 V
4th (attachment) lever: Full EXTEND	3.90 to 4.40 V				
4th (attachment) lever: Full RETRACT	0.60 to 1.10 V				

### Circuit diagram related to 4th (attachment) lever potentiometer (4-lever specification)

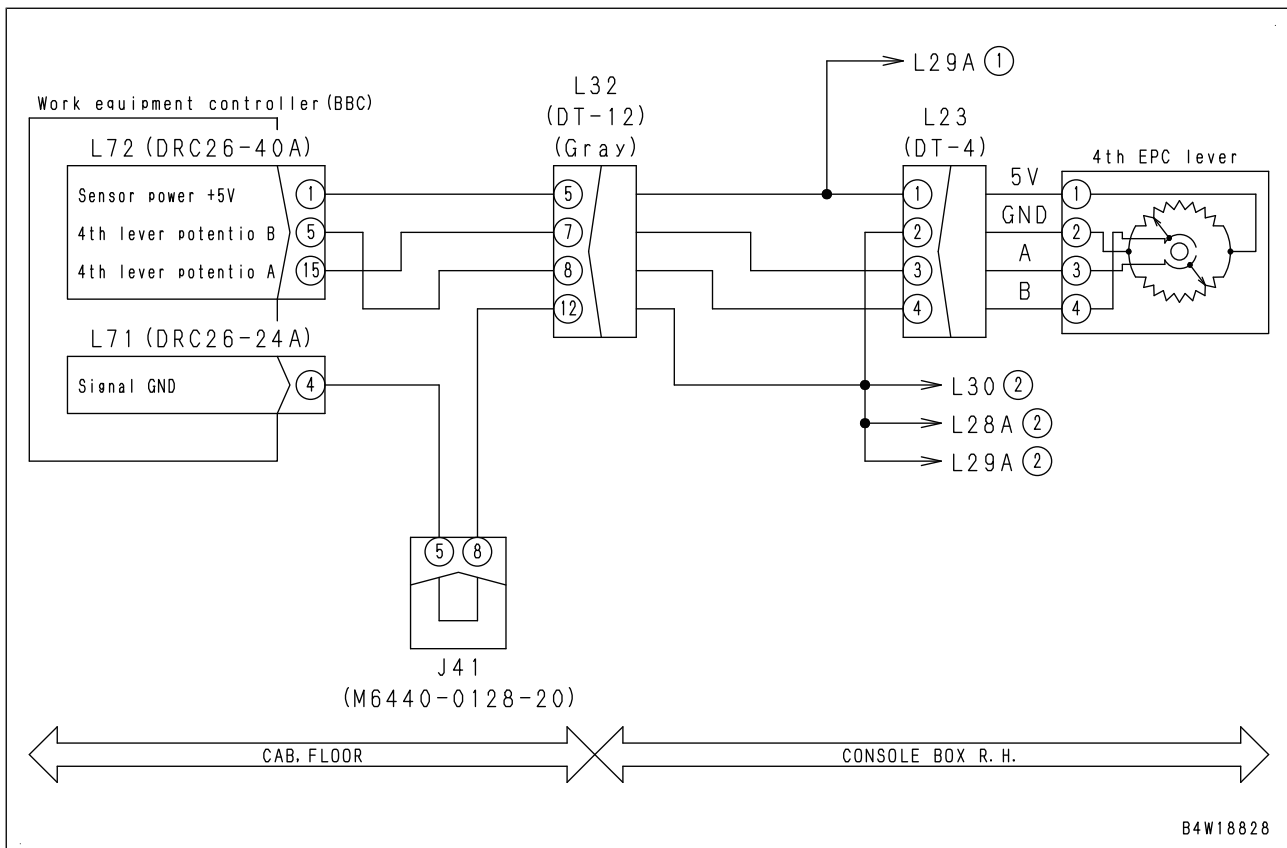

No.	Cause	Procedure, measuring location, criteria and remarks			
4	Defective work equipment controller	If no failure is not found in above checks, work equipment controller is defective.			
		<ul style="list-style-type: none"> <li>• Reference</li> <li>1. Turn starting switch to OFF position.</li> <li>2. Insert T-adapters into connector L72.</li> <li>3. Turn starting switch to ON position.</li> <li>4. Operate bucket lever to perform troubleshooting.</li> </ul>			
		Voltage	Between L72 (36) and ground	Always	2.5 to 4.7 V
				Full TILT	4.2 to 4.7 V
		Full DUMP	2.5 to 3.0 V		

**Circuit diagram related to bucket angle sensor**

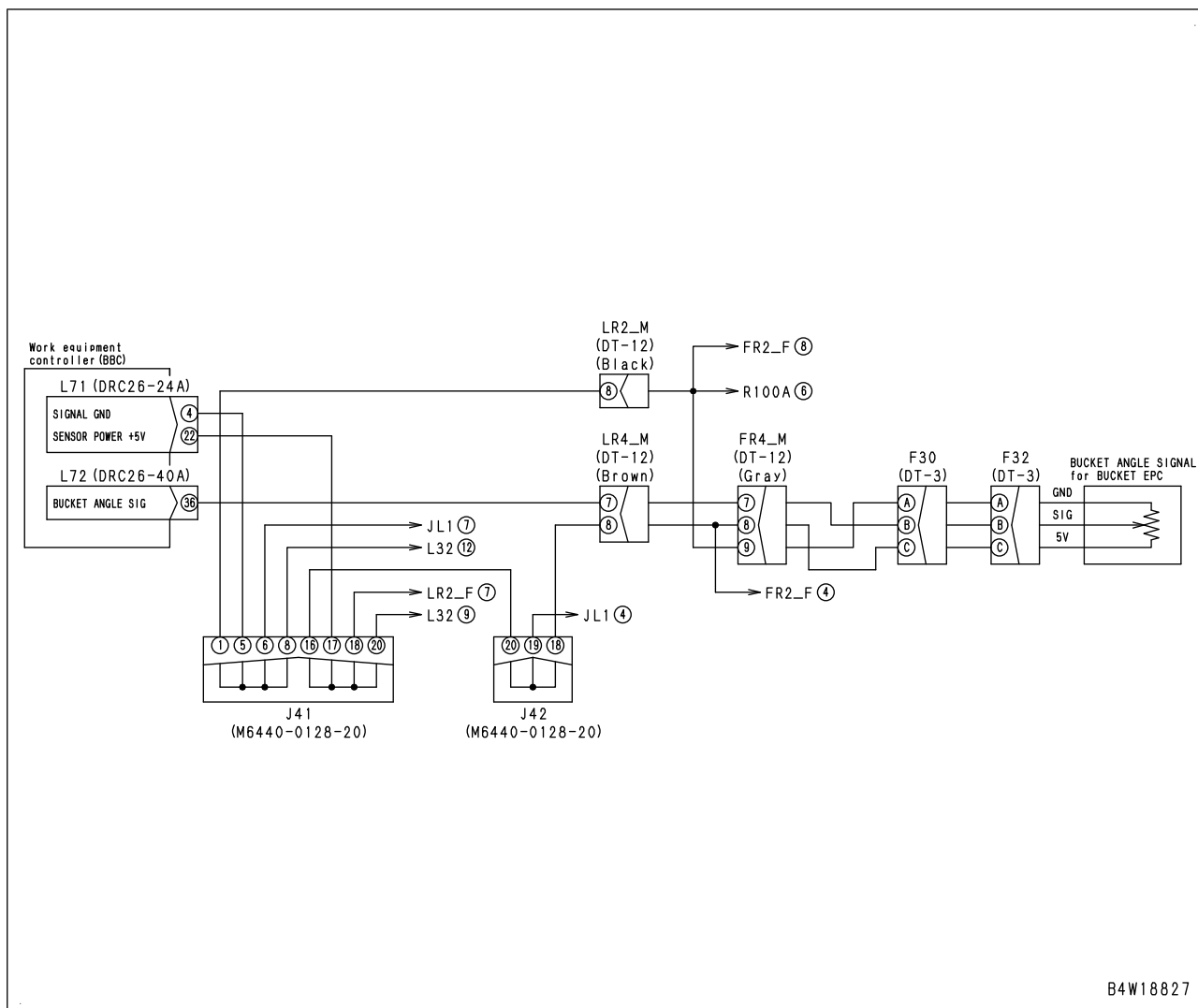

# 40 Troubleshooting

## Troubleshooting by failure code (Display of code)

### Circuit diagram related to machine monitor power supply

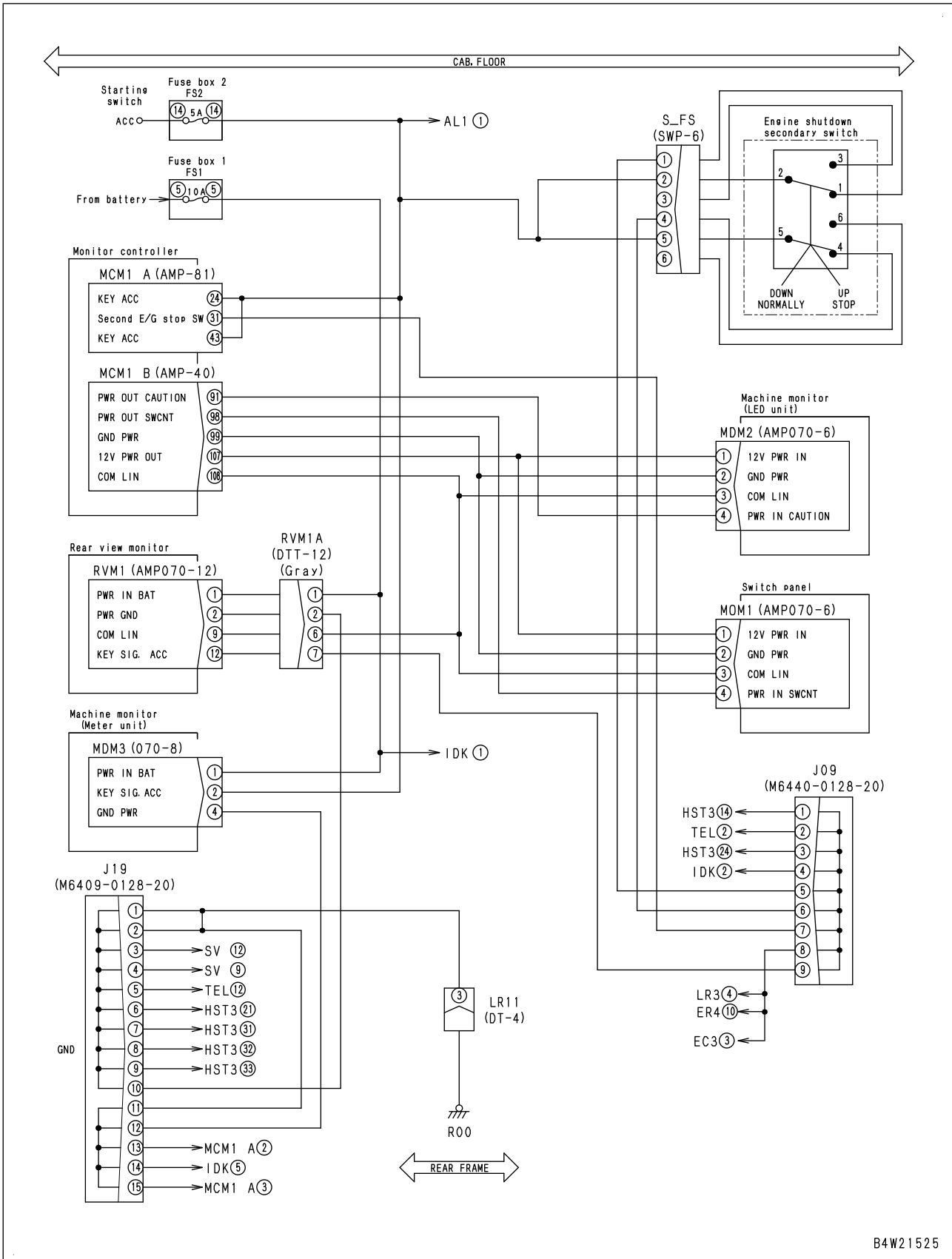

B4W21525

## Failure code [DW4RKA] Disconnection of Bucket EPC Sol. (Tilt) (WA380\_7-

DW4RKA-400-A-Z0-A)

Action level	Failure code	Failure	Disconnection of Bucket EPC Solenoid (Tilt) (Work equipment controller system)
L03	DW4RKA		
Detail of failure	<ul style="list-style-type: none"> <li>Due to open circuit in signal output circuit to bucket TILT EPC solenoid, no current flows when controller drives bucket TILT EPC solenoid.</li> </ul>		
Action of controller	<ul style="list-style-type: none"> <li>Lights up centralized warning lamp and sounds alarm buzzer.</li> <li>Even if cause of failure disappears, machine does not become normal until starting switch is turned to OFF position.</li> </ul>		
Problem on machine	<ul style="list-style-type: none"> <li>Bucket does not tilt.</li> </ul>		
Related information	<ul style="list-style-type: none"> <li>Output current value to bucket TILT EPC solenoid can be checked with monitoring function. (Code: 41902 Bucket Tilt EPC Current)</li> <li>Method of reproducing failure code: Start engine and perform bucket TILT operation.</li> </ul>		

No.	Cause	Procedure, measuring location, criteria and remarks	
1	Defective bucket TILT EPC solenoid (internal open circuit)	1. Turn starting switch to OFF position. 2. Disconnect connector F21 and connect T-adapter to male side.	
		Resistance	Between F21 (male) (1) and (2)      5 to 15 Ω
2	Open circuit, short circuit, ground fault, hot short circuit of wiring harness, or defective transmission controller	1. Turn starting switch to OFF position. 2. Disconnect connector F21 and connect T-adapters to female side. 3. Turn starting switch to ON position. ★ Shake the wiring harness by hand while measuring the voltage. If the voltage drops to approximately 0 V during shaking, circuit is open around this point.	
		Voltage	Between F21 (female) (1) and (2)      1 to 4.5 V
3	Open or short circuit in wiring harness	★ If no failure is found by check on cause 2, this check is not required. 1. Turn starting switch to OFF position. 2. Disconnect connector L73, and connect T-adapter to female side. ★ If resistance is 1 MΩ or higher, wiring harness has open circuit. If resistance is 1 Ω or below, wiring harness has short circuit.	
		Resistance	Between L73 (female) (37) and (3)      5 to 15 Ω
4	Open circuit in wiring harness (wire breakage or defective contact of connector)	★ If no failure is found by check on cause 3, this check is not required. 1. Turn starting switch to OFF position. 2. Disconnect connectors L73 and F21, and connect T-adapters to each female side.	
		Resistance	Between L73 (female) (3) and F21 (female) (2)      Max. 1 Ω Between L73 (female) (37) and F21 (female) (1)      Max. 1 Ω
5	Defective work equipment controller	If no failure is found by above checks, work equipment controller may be defective. (Since this is an internal defect, troubleshooting cannot be performed.)	

# 40 Troubleshooting

## Troubleshooting by failure code (Display of code)

### Circuit diagram related to magnet detent solenoid (2-lever specification or 3-lever specification)

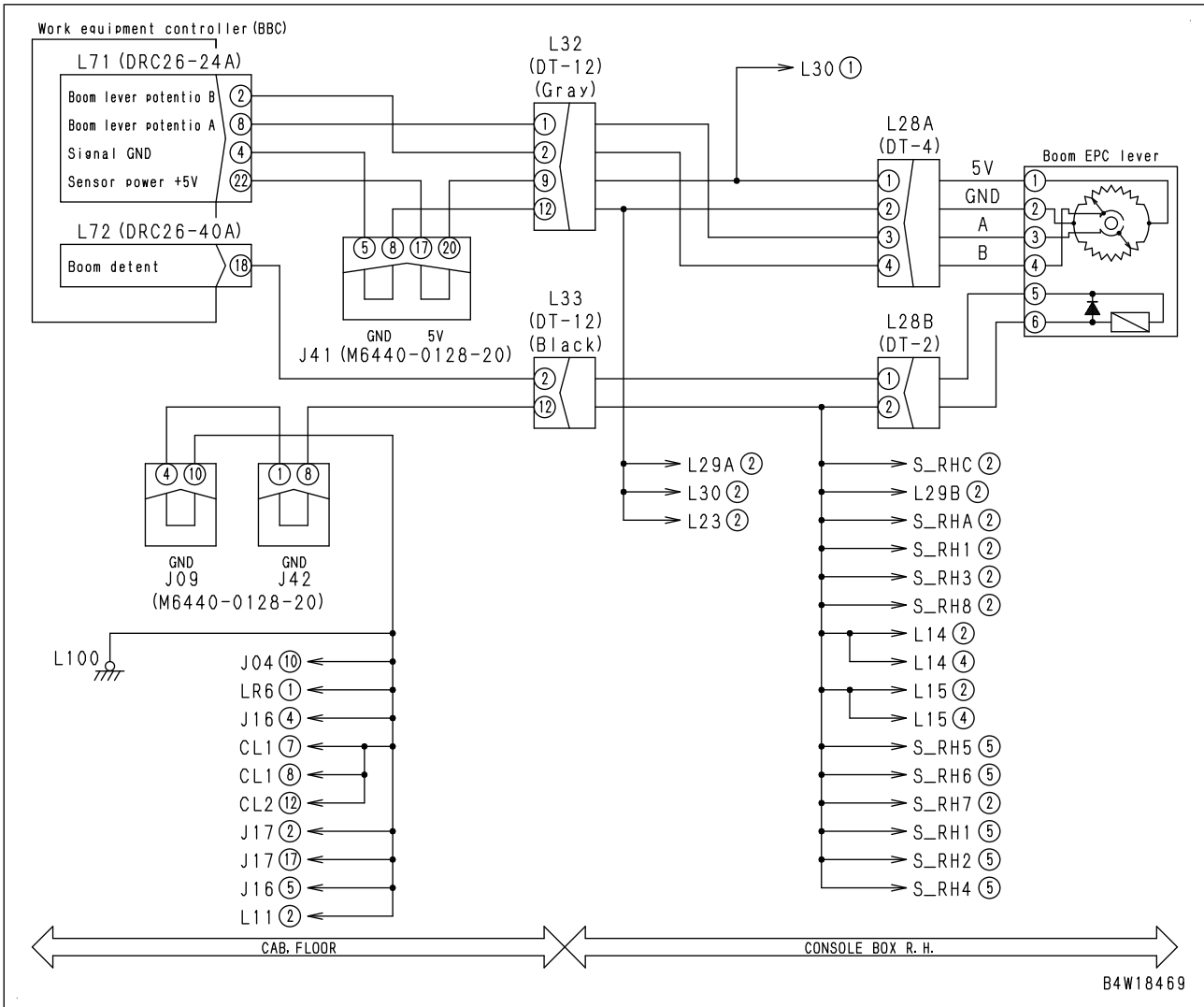

## Failure code [DX16KA] Disconnection of Rad. Fan Pump EPC Sol. (WA380\_7-

DX16KA-400-A-Z0-A)

Action level	Failure code	Failure	Disconnection of Radiator Fan Pump EPC Solenoid (Transmission controller system)
L03	DX16KA		
Detail of failure	<ul style="list-style-type: none"> <li>Due to open circuit in fan pump EPC solenoid circuit, no current flows when controller drives fan pump EPC solenoid.</li> </ul>		
Action of controller	<ul style="list-style-type: none"> <li>Disables fan to rotate in reverse direction.</li> <li>Even if cause of failure disappears, machine does not become normal until starting switch is turned to OFF position.</li> </ul>		
Problem on machine	<ul style="list-style-type: none"> <li>Fan rotates at its maximum speed.</li> <li>Fan cannot rotate in reverse direction.</li> <li>When this failure occurs with fan rotating in reverse direction, fan rotation direction switches to normal direction.</li> </ul>		
Related information	<ul style="list-style-type: none"> <li>Output current value to fan pump EPC solenoid can be checked with monitoring function. (Code: 41400 Rad. Fan Pump EPC Sol. Current)</li> <li>Method of reproducing failure code: Turn starting switch to ON position.</li> </ul>		

No.	Cause	Procedure, measuring location, criteria and remarks		
1	Defective fan pump EPC solenoid (internal open circuit)	1. Turn starting switch to OFF position. 2. Disconnect connector R29, and connect T-adapter to male side.		
		Resistance	Between R29 (male) (1) and (2)	5 to 10 Ω
2	Open or short circuit in wiring harness	1. Turn starting switch to OFF position. 2. Disconnect connector L63, and connect T-adapter to female side. ★ If resistance is 1 MΩ or higher, wiring harness has open circuit. If resistance is 1 Ω or below, wiring harness has short circuit.		
		Resistance	Between L63 (female) (25) and (23)	5 to 10 Ω
3	Open circuit in wiring harness (wire breakage or defective contact of connector)	★ If no failure is found by check on cause 2, this check is not required. 1. Turn starting switch to OFF position. 2. Disconnect connectors L63 and R29, and connect T-adapters to each female side.		
		Resistance	Between L63 (female) (23) and R29 (female) (2)	Max. 1 Ω
		Resistance	Between L63 (female) (25) and R29 (female) (1)	Max. 1 Ω
4	Defective transmission controller	If no failure is found by above checks, transmission controller may be defective. (Since this is an internal defect, troubleshooting cannot be performed.)		

## 40 Troubleshooting

Troubleshooting by failure code (Display of code)

### Failure code [DXH4KA] Disconnection of ECMV Solenoid (1st) (WA380\_7-DXH4KA-

400-A-Z0-A)

Action level	Failure code	Failure	Disconnection of ECMV Solenoid (1st) (Transmission controller system)
L03	DXH4KA		
Detail of failure	<ul style="list-style-type: none"> <li>Due to open circuit in 1st clutch ECMV solenoid circuit, no current flows when controller drives 1st clutch ECMV solenoid.</li> </ul>		
Action of controller	<ul style="list-style-type: none"> <li>Stops driving 1st clutch ECMV solenoid.</li> <li>Lights up centralized warning lamp and sounds alarm buzzer.</li> <li>Even if cause of failure disappears, machine does not become normal until starting switch is turned to OFF position.</li> </ul>		
Problem on machine	<ul style="list-style-type: none"> <li>1st clutch is not engaged (machine can travel with any gear speed other than 1st).</li> </ul>		
Related information	<ul style="list-style-type: none"> <li>Output current value to 1st clutch ECMV solenoid can be checked with monitoring function. (Code: 31602 ECMV Current (1st))</li> <li>Method of reproducing failure code: Turn starting switch to ON position and set transmission shift mode selector switch to AUTO shift mode, or set transmission shift mode selector switch to MANUAL shift mode and select 1st gear speed by using shift down switch or gear shift lever.</li> </ul>		

No.	Cause	Procedure, measuring location, criteria and remarks	
1	Defective 1st clutch ECMV solenoid	1. Turn starting switch to OFF position. 2. Disconnect connector 1.PS, and connect T-adapter to male side.	
		Resistance	Between 1.PS (male) (1) and (2)   5 to 15 Ω
2	Open circuit, short circuit, ground fault, hot short circuit of wiring harness, or defective transmission controller	1. Turn starting switch to OFF position. 2. Disconnect connector 1.PS, and connect T-adapter to female side. 3. Turn starting switch to ON position. ★ Shake the wiring harness by hand while measuring the voltage. If the voltage drops to approximately 0 V during shaking, wiring harness is open at this point.	
		Voltage	Between 1.PS (female) (1) and (2)   1 to 4.5 V
3	Open or short circuit in wiring harness	★ If no failure is found by check on cause 2, this check is not required. 1. Turn starting switch to OFF position. 2. Disconnect connector L63, and connect T-adapter to female side.	
		Resistance	Between L63 (female) (27) and (13)   5 to 15 Ω
4	Open circuit in wiring harness (wire breakage or defective contact of connector)	★ If no failure is found by check on cause 3, this check is not required. 1. Turn starting switch to OFF position. 2. Disconnect connectors L63 and 1.PS, and connect T-adapters to each female side.	
		Resistance	Between L63 (female) (27) and 1.PS (female) (1)   Max. 1 Ω
		Resistance	Between L63 (female) (13) and 1.PS (female) (2)   Max. 1 Ω
5	Defective transmission controller	If no failure is found by above checks, transmission controller is defective. (Since this is an internal defect, troubleshooting cannot be performed.)	

Circuit diagram related to R clutch ECMV solenoid

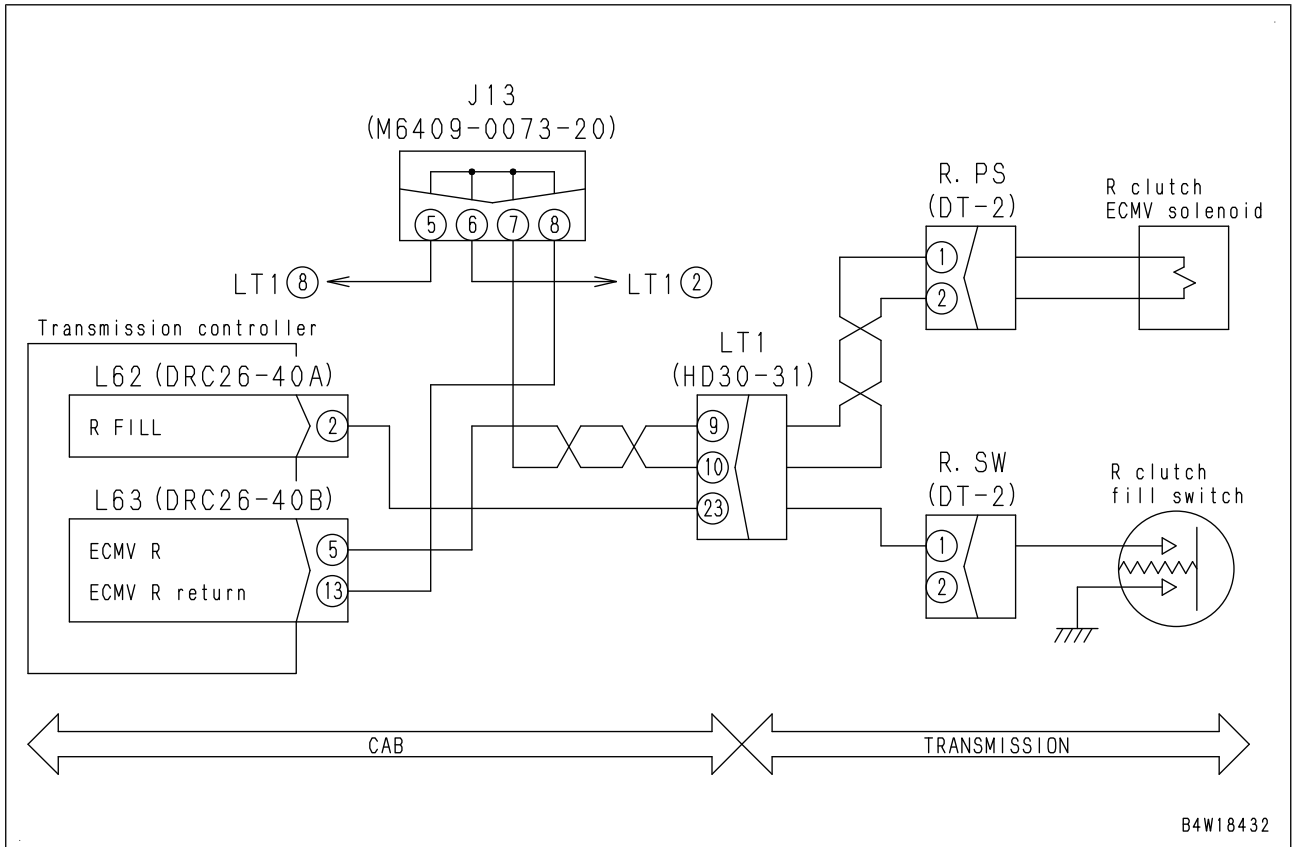

## 40 Troubleshooting

### Troubleshooting by failure code (Display of code)

## Failure code [DXHKKY] Hot Short of 3rd EPC Solenoid (RET) (WA380\_7-DXHKKY-

400-A-Z0-A)

Action level	Failure code	Failure	Hot Short of 3rd EPC Solenoid (Retract) (Work equipment controller system)
L03	DXHKKY		
Detail of failure	<ul style="list-style-type: none"> <li>Due to hot short circuit in output signal circuit to 3rd valve (attachment) retract EPC solenoid, abnormal voltage appears when controller does not drive 3rd valve (attachment) retract EPC solenoid.</li> </ul>		
Action of controller	<ul style="list-style-type: none"> <li>Drives work equipment neutral lock solenoid.</li> <li>Stops driving boom RAISE and LOWER EPC solenoids, bucket TILT and DUMP EPC solenoids, 3rd valve (attachment) EXTEND and RETRACT EPC solenoids, and 4th valve (attachment) EXTEND and RETRACT EPC solenoids.</li> <li>Stops driving every work equipment detent.</li> <li>Lights up centralized warning lamp and sounds alarm buzzer.</li> <li>Even if cause of failure disappears, machine does not become normal until starting switch is turned to OFF position.</li> </ul>		
Problem on machine	<ul style="list-style-type: none"> <li>Cylinder connected to 3rd valve (attachment) does not retract.</li> <li>3rd valve (attachment) retract EPC solenoid may be burnt out.</li> </ul>		
Related information	<ul style="list-style-type: none"> <li>This failure code does not appear on a machine that is not equipped with 3rd valve (attachment). If this failure code is displayed on the machine, select "None" for 3rd (attachment) lever setting on option setting screen of machine monitor.</li> <li>Output current value to 3rd valve (attachment) retract EPC solenoid can be checked with monitoring function. (Code: 41907 3rd Retract EPC Current)</li> <li>Only for machines equipped with 3rd valve (attachment)</li> <li>Method of reproducing failure code: Start engine.</li> </ul>		

No.	Cause	Procedure, measuring location, criteria and remarks		
1	Defective 3rd valve (attachment) retract EPC solenoid (internal short circuit)	1. Turn starting switch to OFF position. 2. Disconnect connector F26, and connect T-adapter to male side.		
		Resistance	Between F26 (male) (1) and (2)	5 to 15 Ω
2	Hot short circuit in wiring harness	1. Turn starting switch to OFF position. 2. Disconnect connector F26, and connect T-adapter to female side. 3. Turn starting switch to ON position.		
		Voltage	Between F26 (female) (1) and (2)	Max. 4.5 V
3	Short circuit in wiring harness	1. Turn starting switch to OFF position. 2. Disconnect connectors L73 and F26, and connect T-adapter to female side of L73.  ★ Check by using multimeter in continuity mode.		
		Continuity	Between L73 (female) (36) and each pin other than pin (36)	No continuity (No sound is heard)
4	Defective work equipment controller	If no failure is found by above checks, work equipment controller may be defective. (Since this is an internal defect, troubleshooting cannot be performed.)		

**Failure code [H2K0KA] Failure of Quick Coupler Lock Signal** (WA380\_7-H2K0KA-400-

A-Z0-A)

Action level	Failure code	Failure	Failure of Quick Coupler Lock Signal (Work equipment controller system)
L03	H2K0KA		
Detail of failure	<ul style="list-style-type: none"> <li>Neither of ON and OFF signals of multi-coupler release switch is not detected due to open circuit or ground fault in signal circuit of multi-coupler release switch.</li> </ul>		
Action of controller	<ul style="list-style-type: none"> <li>Lights up centralized warning lamp and sounds alarm buzzer.</li> <li>If cause of failure disappears, machine becomes normal by itself.</li> </ul>		
Problem on machine	<ul style="list-style-type: none"> <li>Switch operation of multi-coupler release switch becomes ineffective.</li> <li>"Multi-coupler lock OFF" indicator does not light up while multi-coupler release switch is set to ON position.</li> </ul>		
Related information	<ul style="list-style-type: none"> <li>Input signal (ON/OFF) from multi-coupler release switch can be checked with monitoring function. (Code: 02219 Work Equipment Controller Input 3, Quick Coupl. Rel. SW)</li> <li>Multi-coupler release switch OFF signal can be checked with monitoring function. (Code: 02219 Work Equipment Controller Input 3, Quick Coupl. Rel. SW OFF)</li> <li>Applied only to multi-coupler specification machines for KA and KOHAG</li> </ul>		

No.	Cause	Procedure, measuring location, criteria and remarks			
1	Defective slow-blow fuse	If 50 A fuse on terminal R06B side is blown, circuit probably has ground fault. Go to check on cause 6.			
2	Defective fuse-14 in fuse box FS9	If fuse-14 in fuse box FS9 is blown, circuit probably has ground fault. Go to check on cause 6.			
3	Defective multi-coupler release switch (internal open or short circuit)	1. Turn starting switch to OFF position. 2. Disconnect connector L40, and connect T-adaptor to male side.			
		Resistance	Between L40 (male) (A) and (B)	Multi-coupler release switch: ON	Max. 1 Ω
				Multi-coupler release switch: OFF	Min. 1 MΩ
			Between L40 (male) (A) and (C)	Multi-coupler release switch: ON	Min. 1 MΩ
Multi-coupler release switch: OFF	Max. 1 Ω				
4	Open circuit 1 in wiring harness (wire breakage or defective contact of connector)	1. Turn starting switch to OFF position. 2. Disconnect connector MLT, and connect T-adaptor to female side.			
		Resistance	Between MLT (female) (2) and ground	Max. 1 Ω	
		1. Turn starting switch to OFF position. 2. Disconnect connector MLT, and connect T-adaptor to female side. 3. Turn starting switch to ON position.			
		Voltage	Between MLT (female) (3) and (2)	20 to 30 V	
5	Open circuit 2 in wiring harness (wire breakage or defective contact of connector)	★ If no failure is found by check on "Open circuit 1 in wiring harness", this check is not required. 1. Turn starting switch to OFF position. 2. Disconnect connectors L40, L73, and MLT, and connect T-adaptor to female side. 3. Remove 50 A fuse on terminal R06B side and fuse-14 in fuse box FS9.			
		Resistance	Between terminal R06B of slow-blow fuse and FS9-14 in fuse box 2	Max. 1 Ω	
			Between FS9-14 and L40 (female) (A)	Max. 1 Ω	
			Between L40 (female) (B) and L73 (female) (9)	Max. 1 Ω	
			Between L73 (female) (9) and MLT (female) (3)	Max. 1 Ω	
	Between L40 (female) (C) and L73 (female) (40)	Max. 1 Ω			

## 40 Troubleshooting

### Troubleshooting of electrical system (E-mode)

#### E-6 LCD unit on machine monitor displays nothing (WA380\_7-FH8-400-A-Z0-A)

Failure	LCD unit on machine monitor displays nothing.
Related information	<ul style="list-style-type: none"> <li>• Display of LED unit, meter unit, and rearview monitor is normal.</li> <li>• Make harness checker. For details, see "Processing procedure of harness checker for troubleshooting of machine monitor LCD unit" in General information on troubleshooting.</li> </ul> <p>★ Harness checker for troubleshooting of machine monitor LCD unit is simply referred to as "harness checker".</p>

No.	Cause	Procedure, measuring location, criteria and remarks						
1	Defective harness connector	<ol style="list-style-type: none"> <li>1. Turn starting switch to OFF position.</li> <li>2. Turn the battery disconnect switch to OFF position.</li> <li>3. Visually check connectors of wiring harness between LCD unit of machine monitor and monitor controller, and repeat connection and disconnection of connectors.</li> <li>4. Turn battery disconnect switch to ON position.</li> <li>5. Turn starting switch to ON position.</li> </ol> <p>If normal conditions are restored, cause of failure is defective contact of connector.</p>						
2	Defective LCD unit of machine monitor	<p>★ When using harness checker</p> <ol style="list-style-type: none"> <li>1. Turn starting switch to OFF position.</li> <li>2. Check that system operating lamp does not light up, and then set battery disconnect switch to OFF position.</li> <li>3. Disconnect connector MCM2, and connect harness checker to female side.</li> <li>4. Turn battery disconnect switch to ON position.</li> <li>5. Turn starting switch to ON position.</li> </ol> <table border="1"> <tr> <td>Voltage</td> <td>Between harness checker (5) and (3)</td> <td>6.2 to 9.1 V</td> </tr> <tr> <td></td> <td>Between harness checker (7) and (3)</td> <td>6.2 to 9.1 V</td> </tr> </table>	Voltage	Between harness checker (5) and (3)	6.2 to 9.1 V		Between harness checker (7) and (3)	6.2 to 9.1 V
Voltage	Between harness checker (5) and (3)	6.2 to 9.1 V						
	Between harness checker (7) and (3)	6.2 to 9.1 V						
3	Open circuit in wiring harness (wire breakage or defective contact of connector)	<p>★ When performing troubleshooting by using new wiring harness between machine monitor LCD unit and monitor controller</p> <ol style="list-style-type: none"> <li>1. Turn starting switch to OFF position.</li> <li>2. Check that system operating lamp does not light up, and then set battery disconnect switch to OFF position.</li> <li>3. Replace wiring harness between LCD unit of machine monitor and monitor controller with new one.</li> <li>4. Turn battery disconnect switch to ON position.</li> <li>5. Turn starting switch to ON position.</li> </ol> <p>If normal conditions are restored, wiring harness between LCD unit of machine monitor and monitor controller is defective.</p>						
4	Defective LCD unit of machine monitor	<ol style="list-style-type: none"> <li>1. Turn battery disconnect switch to ON position.</li> <li>2. Turn starting switch to ON position.</li> </ol> <p>If display of LED unit and meter unit is normal, LCD unit is defective.</p>						
5	Defective monitor controller	<ol style="list-style-type: none"> <li>1. Turn battery disconnect switch to ON position.</li> <li>2. Turn starting switch to ON position.</li> </ol> <p>If display of LED unit and meter unit is unusual, monitor controller is defective.</p>						

Wiring harness of rearview monitor

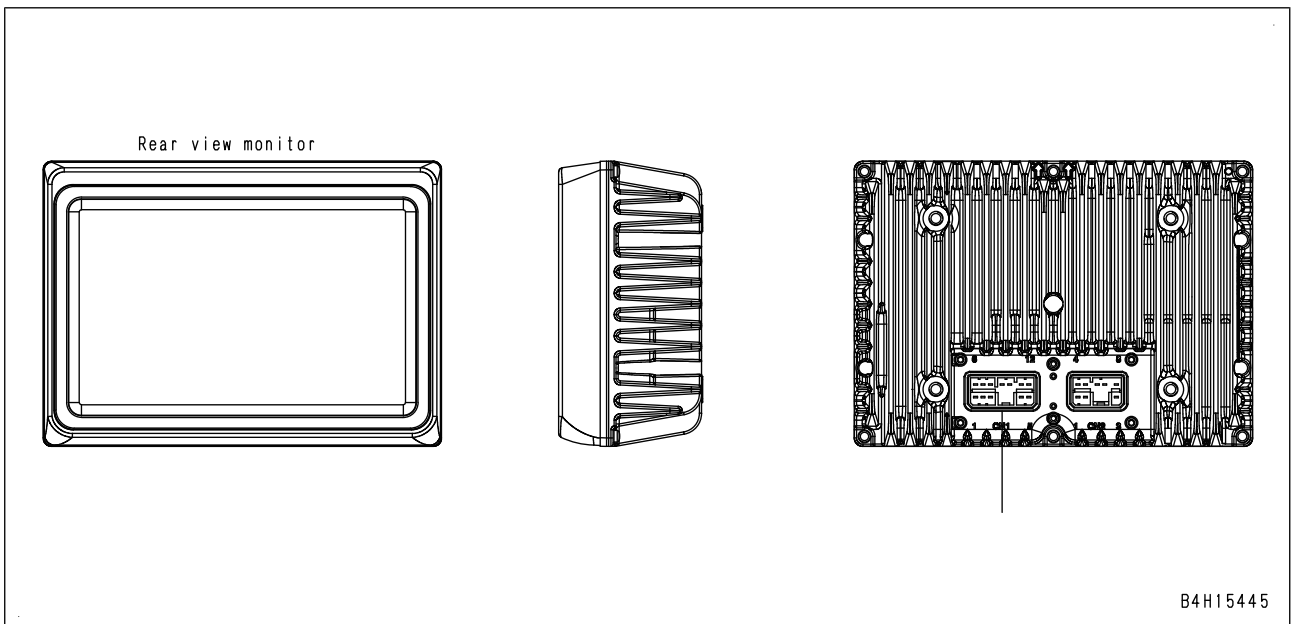

## 40 Troubleshooting

### Troubleshooting of electrical system (E-mode)

No.	Cause	Procedure, measuring location, criteria and remarks	
6	Short circuit in wiring harness	1. Turn starting switch to OFF position. 2. Disconnect connectors MCM1 A and R33, and connect T-adapters to female side of MCM1 A. ★ Check by using multimeter in continuity mode.	
		Continuity	Between MCM1 A (female) (8) and each pin other than pin (8) No continuity (No sound is heard)
7	Defective monitor controller	If no failure is found by above checks, monitor controller is defective.	

#### Circuit diagram related to fuel level sensor

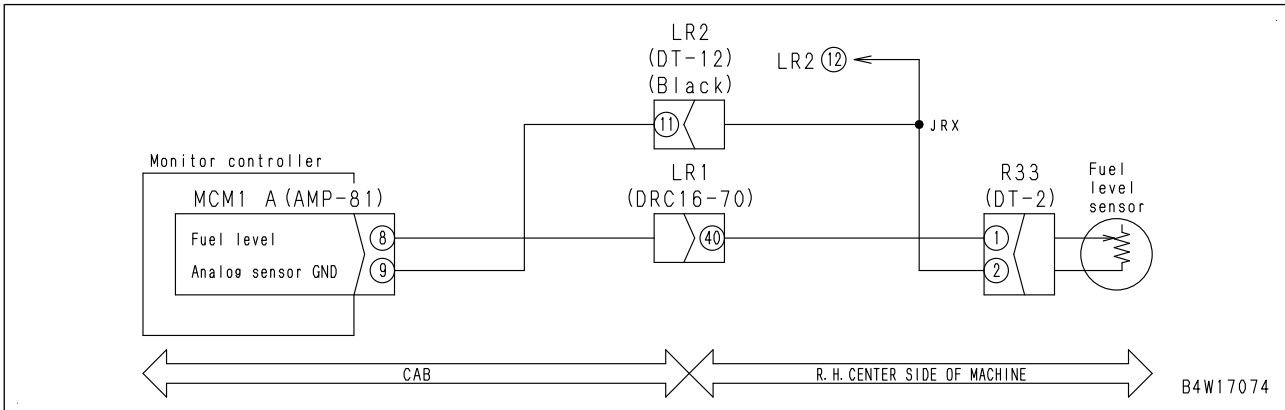

Circuit diagram related to engine power selection switch

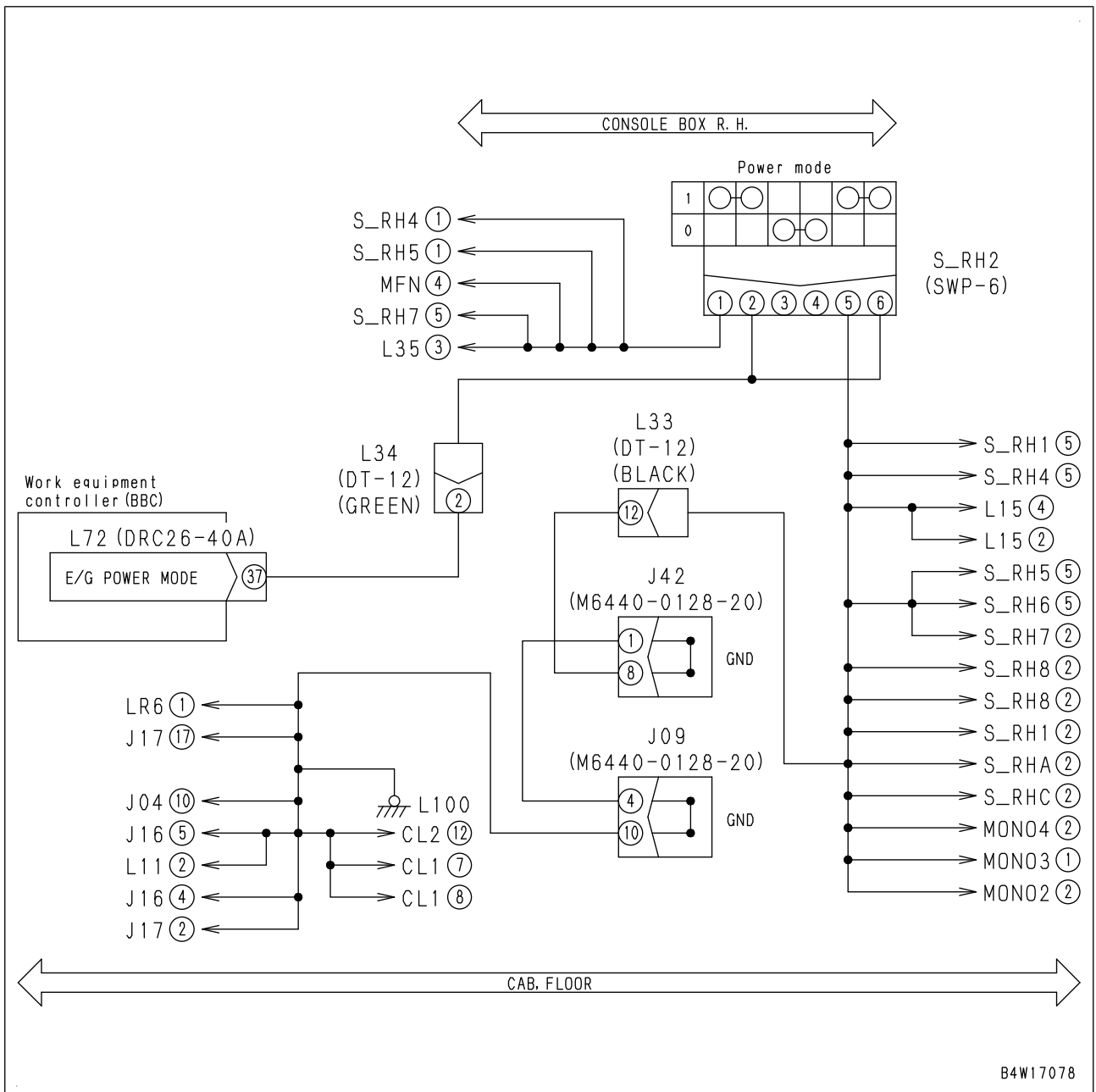

B4W17078

## 40 Troubleshooting

### Troubleshooting of electrical system (E-mode)

## E-48 All of turn signal lamps and hazard lamps do not light up or go out

(WA380\_7-HS4-400-A-Z0-A)

Failure	All of turn signal lamps and hazard lamps do not light up or go out.
Related information	<ul style="list-style-type: none"> <li>Defective switch, lamps or wiring harness of turn signal lamps and hazard lamp circuits</li> <li>If turn signal lamps and hazard lamps do not go out, remove winker hazard lamp relay 2. If turn signal lamps and hazard lamps then go out, winker hazard lamp relay 2 is defective.</li> <li>If all turn signal lamps and hazard lamps do not flash, try another flasher unit.</li> <li>Input condition (ON/OFF) to machine monitor from turn signal lamp and hazard lamp switches (right turn signal lamp) can be checked with monitoring function (Code: 04507 Right Turn Signal).</li> <li>Input condition (ON/OFF) to machine monitor from turn signal lamp and hazard lamp switches (left turn signal lamp) can be checked with monitoring function (Code: 04507 Let Turn Signal).</li> </ul>

No.	Cause	Procedure, measuring location, criteria and remarks			
1	Defective slow-blow fuse	If a slow-blow fuse is blown, circuit may have ground fault, etc. (See check on cause 8.)			
2	Defective winker hazard lamp relay 1 L111	<ol style="list-style-type: none"> <li>Turn starting switch to OFF position.</li> <li>Replace winker hazard lamp relay 1 L111 with another relay, for example, horn relay L119.</li> <li>Turn starting switch to ON position.</li> <li>Turn ON and OFF hazard lamp switch</li> <li>Operate turn signal lever to right and left</li> </ol> If turn signal lamps become normal, original winker hazard lamp relay 1 L111 is defective.			
3	Defective winker hazard lamp relay 2 L122	<ol style="list-style-type: none"> <li>Turn starting switch to OFF position.</li> <li>Replace winker hazard lamp relay 2 L122</li> <li>Turn starting switch to ON position.</li> <li>Turn ON and OFF hazard lamp switch</li> <li>Operate turn signal lever to right and left</li> </ol> If turn signal lamps become normal, original winker hazard lamp relay 2 L122 is defective.			
4	Defective turn signal switch (Internal open or short circuit)	<ol style="list-style-type: none"> <li>Turn starting switch to OFF position.</li> <li>Disconnect connector L04.</li> <li>Turn starting switch to ON position.</li> <li>Turn ON and OFF hazard lamp switch</li> </ol> If turn signal lamps become normal, turn signal switch is defective.			
5	Defective hazard lamp switch (internal open or short circuit)	<ol style="list-style-type: none"> <li>Turn starting switch to OFF position.</li> <li>Disconnect connector S_FB.</li> <li>Turn starting switch to ON position.</li> <li>Operate turn signal lever to right and left</li> </ol> If turn signal lamps become normal, hazard lamp switch is defective.			
6	Open circuit in wiring harness 1 (wire breakage or defective contact of connector)	<ul style="list-style-type: none"> <li>Flasher unit power supply</li> <li>1. Turn starting switch to OFF position.</li> <li>2. Disconnect connector L19 and connect T-adapters to female side.</li> <li>★ If check result is unusual, go to check on cause 7.</li> <li>3. Turn starting switch to ON position.</li> </ul> <table border="1" style="width: 100%; border-collapse: collapse;"> <tr> <td style="width: 15%;">Voltage</td> <td style="width: 60%;">Between L19 (female) (3) and (1)</td> <td style="width: 25%;">20 to 30 V</td> </tr> </table>	Voltage	Between L19 (female) (3) and (1)	20 to 30 V
Voltage	Between L19 (female) (3) and (1)	20 to 30 V			

No.	Cause	Procedure, measuring location, criteria and remarks		
6	Open circuit in wiring harness (wire breakage or defective contact of connector)	<ul style="list-style-type: none"> <li>• Window washer motor line</li> <li>1. Turn starting switch to OFF position.</li> <li>2. Disconnect connectors L21, R43, R45, and connect T-adapters to female side of L21.</li> </ul>		
		Resistance	Between R43 (female) (2) and ground	Max. 1 Ω
			Between R45 (female) (2) and ground	Max. 1 Ω
			Between L21 (female) (6) and R43 (female) (1)	Max. 1 Ω
			Between L21 (female) (10) and R45 (female) (1)	Max. 1 Ω
<ul style="list-style-type: none"> <li>• Front wiper operation related checks</li> <li>★ If front wiper operates when front window washer is activated, this check is not required.</li> <li>1. Turn starting switch to OFF position.</li> <li>2. Disconnect connectors L21 and L31, and connect T-adaptor to female side of L21.</li> </ul>				
Resistance	Between L31 (female) (2) and L21 (female) (6)	Max. 1 Ω		
7	Ground fault in wiring harness (contact with ground circuit)	<ul style="list-style-type: none"> <li>1. Turn starting switch to OFF position.</li> <li>2. Disconnect connectors L21, L31, R43, R45, D08, D09, and connect T-adapters to female side of L21.</li> </ul>		
		Resistance	Between ground and L21 (female) (6), R43 (female) (1) or L31 (female) (2)	Min. 1 MΩ
			Between ground and L21 (female) (10) or R45 (female) (1)	Min. 1 MΩ
8	Defective interval wiper timer (internal defect)	<ul style="list-style-type: none"> <li>★ If no failure is found by above checks and the front wiper does not operate when the front window washer is activated, the interval wiper timer is defective.</li> </ul>		

## 40 Troubleshooting

Troubleshooting of hydraulic and mechanical system (H-mode)

### H-5 Large shock is made when machine starts or gear is shifted (WA380\_7-C10-

400-A-Z0-A)

Failure	Large shocks are made when machine starts or gear is shifted.		
Related information	<ul style="list-style-type: none"> <li>• It is difficult to determine whether shock you feel is large or small. so, regard shocks as large in following cases.               <ol style="list-style-type: none"> <li>1. When you feel that shock increases significantly and suddenly</li> <li>2. When you feel that shock is larger than that of other machines of same model</li> </ol> </li> <li>• Check that transmission oil level is normal.</li> <li>• If any failure code is displayed, perform trouble shooting for that failure code first. 15SAL1, 15SALH, 15SBL1, 15SBLH, 15SEL1, 15SELH, 15SFL1, 15SFLH, 15SGL1, 15SGLH, 15SHL1, 15SHLH, DGF1KA, or DGF1KB)</li> <li>• Check that drive shaft, etc. are normal.</li> <li>• Engine speed can be checked with monitoring function. (Monitoring code: 01001)</li> <li>• Clutch fill time can be checked with monitoring function. (Monitoring code: 41802 (1st), 41803 (2nd), 41804 (3rd), 41805 (4th), 41806 ( R), 41808 (F))</li> </ul>		
No.	Cause	Procedure, measuring location, criteria and remarks	
1	Defective strainer of transmission charge pump	Check strainer for clogging.	
2	Air sucked in on suction side of transmission charge pump	Check suction piping for cracks, etc.	
3	Defective main relief valve of transmission charge pump	★ Be ready with engine stopped, then perform troubleshooting with engine running at low idle and 2,000 rpm.	
		Main relief pressure	Engine speed
		Low idle	2.31 ± 0.2 MPa {23.5 ± 2 kg/cm <sup>2</sup> }
		2,000 rpm	2.50 ± 0.2 MPa {25.5 ± 2.0 kg/cm <sup>2</sup> }
		When pressure cannot be adjusted to normal level, check main relief valve for malfunction (setting of spring) and internal defect (defective valve seat).	
4	Clogged last chance filter	If no failure is found by check on cause (3) but lockup clutch pressure is low or "0", check last chance filter for clogging.	

## 40 Troubleshooting

### Troubleshooting of hydraulic and mechanical system (H-mode)

No.	Cause	Procedure, measuring location, criteria and remarks		
11	Malfunction of pressure compensation valve of boom control valve	When bucket moves normally and boom can rise with bucket unloaded but cannot rise with bucket loaded, pressure compensation valve of boom control valve may be defective.		
12	Malfunction of pressure compensation valve of bucket control valve	When failure code for unusual boom speed is generated, if bucket tilt-back force and bucket speed are unusual, pressure compensation valve of bucket control valve may be defective.		
13	Malfunction of PC valve	Check PC valve for locking of spool and setting of spring. If any failure is found, replace it.		
14	Malfunction of LS valve	Check LS valve for locking of spool and setting of spring. If any failure is found, replace it.		
15	Defective lift cylinder	★ Be ready with engine stopped, then perform troubleshooting with engine at full speed.		
		If measured relief pressure is low, disconnect hydraulic hose from lift cylinder head end, and relieve lift cylinder hydraulically at it stroke end. If oil flows out of cylinder, cylinder piston ring is defective.		
16	Defective work equipment pump	<ul style="list-style-type: none"> <li>• If measured pressure is unusual in check on cause (7) and main relief valve is normal, disconnect work equipment pump outlet hose, crank engine, and check that oil flows out.</li> <li>• Check return filter and suction strainer for foreign materials such as metal particles.</li> </ul>		
17	Malfunction of back pressure valve	<ul style="list-style-type: none"> <li>• If measured relief pressure is high in check on cause (7), back pressure valve may malfunction. Check spool for seizure and locking.</li> </ul>		
18	Defective cooling fan pump	<ul style="list-style-type: none"> <li>• If measured output pressure of accumulator charge valve is low in check on cause (3), cooling fan pump may be defective.</li> </ul>		
		★ Perform troubleshooting with engine at full speed.		
		Fan speed	Coolant temperature: Min. 95°C Torque converter oil temperature: Min. 105°C Hydraulic oil temperature: Min. 95°C	1,300 to 1,700 rpm
		<ul style="list-style-type: none"> <li>• If fan speed is below standard value, perform troubleshooting for "H-36 Fan speed is abnormal".</li> </ul>		

## 40 Troubleshooting

### Troubleshooting of engine (S-mode)

---

## Troubleshooting of engine (S-mode) (ALL-3840-001-A-03-A)

### Information described in troubleshooting table (S mode) (WA380\_7-5170-010-A-00-A)

(Rev. 2011/01)

- ★ The following information is summarized in the troubleshooting table. Before performing troubleshooting, understand that information fully.

Failure	Failure symptom that appears on engine		
Related information	Information that relates to occurred failure or troubleshooting		
Cause	Point to check, remarks	Remedy	
1 2 3 4 5	Possible cause of failure symptom (No. is reference number and does not indicate priority)	<Information described> <ul style="list-style-type: none"><li>• Detail of check required to determine whether possible cause is applicable or not.</li><li>• Remarks for determination of possible cause</li></ul>	<ul style="list-style-type: none"><li>• Action required to remove possible cause</li></ul>

**S-18 Unusual noise is heard** (PC400-BA1-400-A-Z0-A)

Failure	Unusual noise is heard.
Related information	<ul style="list-style-type: none"> <li>• Check whether noise source is in or outside engine before starting troubleshooting.</li> <li>• Engine runs in low-temperature mode while it is not warmed up sufficiently. Accordingly, engine sound becomes slightly larger. This does not indicate abnormality, however.</li> <li>• When engine accelerates, it switches into acceleration mode and its sound becomes slightly large further for up to approximately 3 to 5 seconds. This does not indicate abnormality, however.</li> <li>• If any failure code is displayed, perform troubleshooting for that code first.</li> </ul>

No.	Cause	Point to check, remarks	Remedy
1	Exhaust gas leakage from piping	<ul style="list-style-type: none"> <li>• Exhaust gas leaks from piping between cylinder head and exhaust manifold, between exhaust manifold and KVGT, or between KVGT outlet and KDPF.</li> <li>• Exhaust gas leaks from EGR piping or air intake piping.</li> </ul>	Repair or replace defective parts.
2	Vibration of exhaust piping or exhaust bellows	<ul style="list-style-type: none"> <li>• Visually check for vibration.</li> </ul>	Check and retighten piping brackets.
3	Seized or broken KVGT	<ul style="list-style-type: none"> <li>• Check whether KVGT shaft rotates. (Move KVGT vanes with hand in axial and radial directions to make judgement.)</li> </ul>	Replace KVGT.
4	Internal damage of KDPF	<ul style="list-style-type: none"> <li>• Check inside of KDPF.</li> </ul>	Clean or replace KDPF.
5	Defective injector	<ul style="list-style-type: none"> <li>• Some cylinder is found to be cool when exhaust manifolds are touched by hand immediately after engine is started.</li> <li>• When engine is run in cylinder cutout mode with some cylinder cut out, engine speed does not change. (Reference: See Testing and adjusting, "Handling cylinder cutout mode operation".)</li> </ul>	Replace injector.
6	Incorrect valve clearance	<ul style="list-style-type: none"> <li>• Check valve clearance. (Reference: See Testing and adjusting, "Testing and adjusting valve clearance".)</li> </ul>	Adjust valve clearance.
7	Seized pin bushing, front bearing, or main bearing	<ul style="list-style-type: none"> <li>• Check for metal particles in oil pan.</li> </ul>	Repair or replace damaged parts.
8	Worn piston ring or cylinder liner	<ul style="list-style-type: none"> <li>• If metal particles is found in oil pan or oil filter, overhaul engine and check piston ring and cylinder liner.</li> <li>• Measure compression pressure (see Standard value table). (Reference: See Testing and adjusting, "Testing compression pressure".)</li> </ul>	Replace piston ring or cylinder liner.
9	Damaged valve or rocker arm	<ul style="list-style-type: none"> <li>• Overhaul engine and check valves and rocker arm parts.</li> </ul>	Replace valve or rocker arm.
10	Damaged idler gear	<ul style="list-style-type: none"> <li>• Overhaul engine and check idler gear parts.</li> </ul>	Replace idler gear.

# 50 Disassembly and assembly

## Related information on disassembly and assembly

Note: Komatsu does not take any responsibility for special tools manufactured according to these sketches.  
 K1-2: Spacer

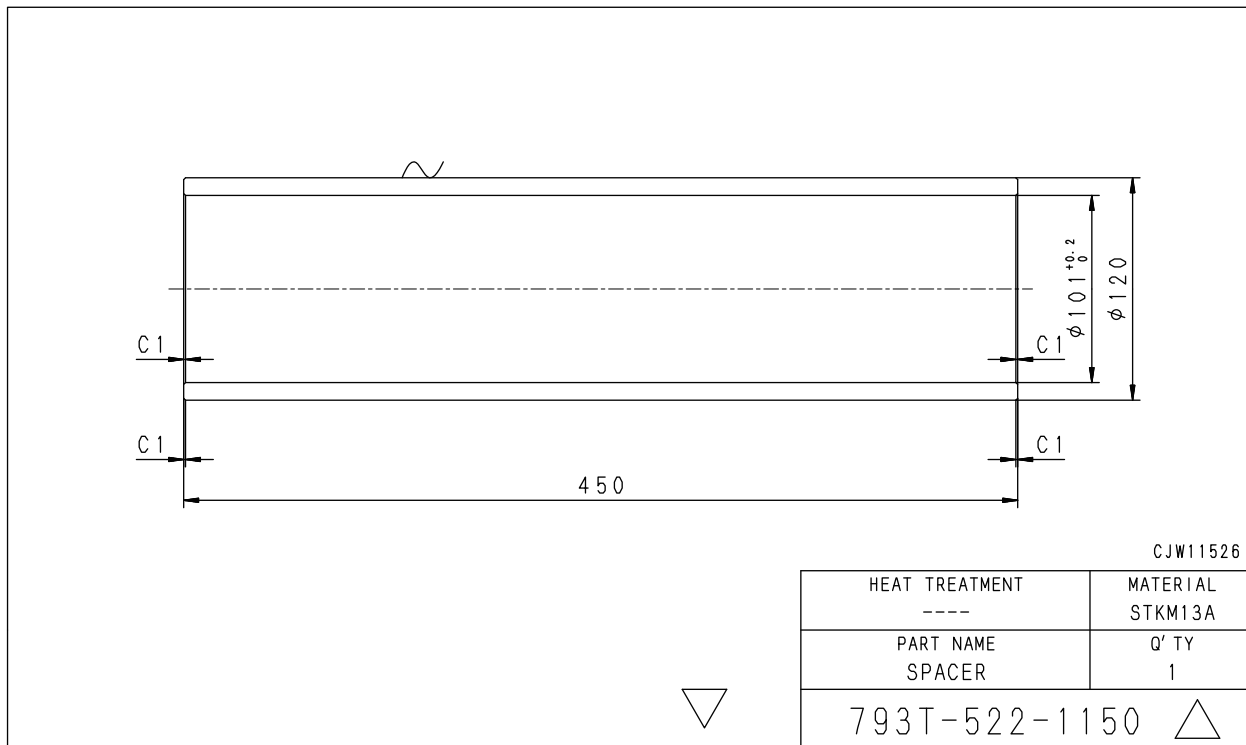

K2: Push tool

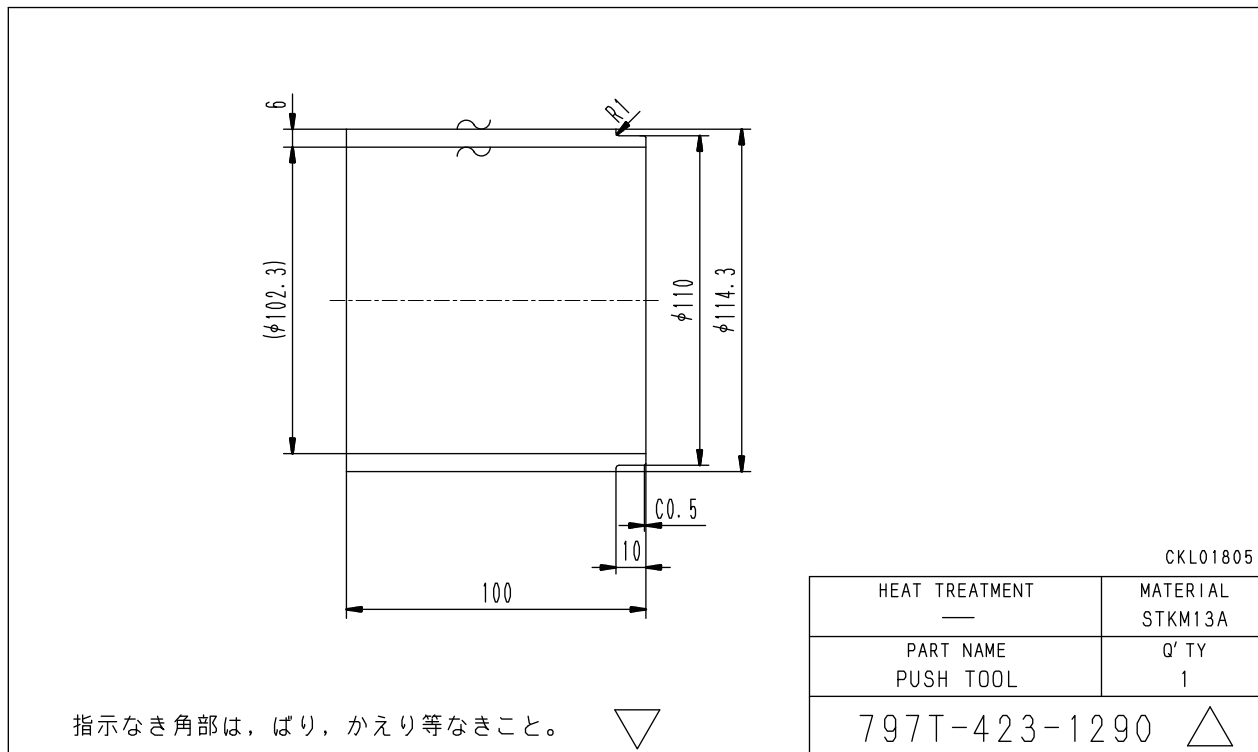

- ★ Take care that dirt and foreign matter do not enter the mounting portion of the injector assembly.

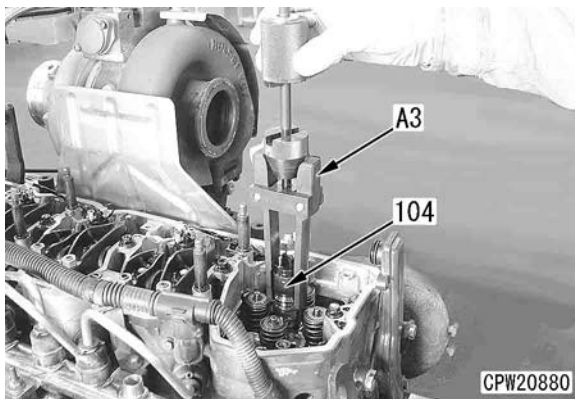

25. Remove push rod (105).
26. Remove mounting bolts (106) to remove rocker housing assembly (107).

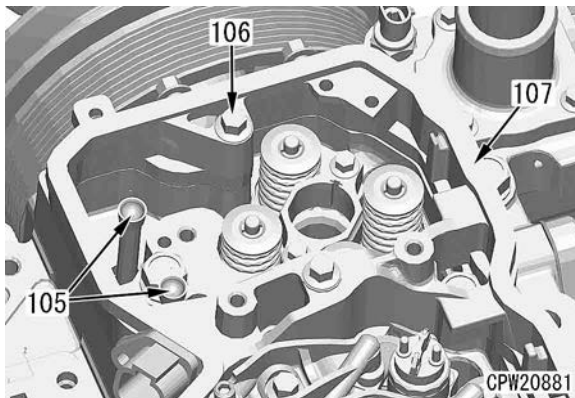

27. Remove 26 mounting bolts (108), and sling and remove cylinder head assembly (109).

 **Cylinder head assembly:**  
**75 kg**

28. Remove cylinder head gasket (110).

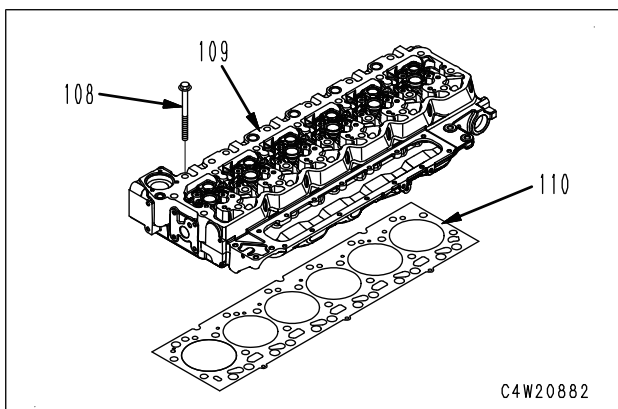

## Installation (WA380-A100-720-K-00-A)

1. Cylinder head assembly
  - 1) Measure stem length "a" of every cylinder head mounting bolt and check that it is within the using limit.

- Using limit length of bolt:  
Below 132.1 mm
- ★ If a bolt is longer than the using limit, do not reuse it but replace it.
- ★ Use tool A7 for measurement.

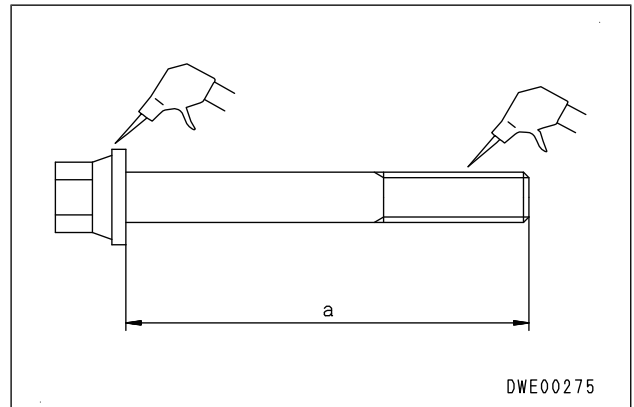

- 2) Install cylinder head gasket (110) to cylinder block.

- ★ Check that cylinder head mounting surface and inside of cylinders are free from dirt or foreign matter.

- ★ Check that cylinder head gasket is aligned with hole on cylinder head.

- 3) Sling and install cylinder head assembly (109) to cylinder block and first tighten mounting bolt (108) two to three turns with you hands.

 **Cylinder head assembly:**  
**75 kg**

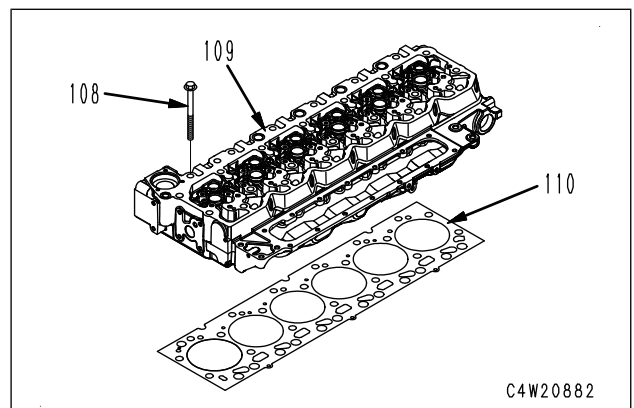

- 4) Tighten cylinder head mounting bolts (108) according to the following procedure in the sequence shown in the figure.

- ★ Apply engine oil to threaded portion and seat surface of head of mounting bolt.

 **Threaded portion and seat surface of head of mounting bolt:**  
**Engine oil (EO15W-40)**

## 50 Disassembly and assembly

### Engine and cooling system

---

★ Install aftercooler hose in compliance with dimensions shown in the figure below.

- Dimension "A": 75 mm
- Dimension "B": 29.3 mm
- Dimension "C": 10 mm
- Dimension "D": 75 mm
- Dimension "E": 29.3 mm
- Dimension "F": 10 mm

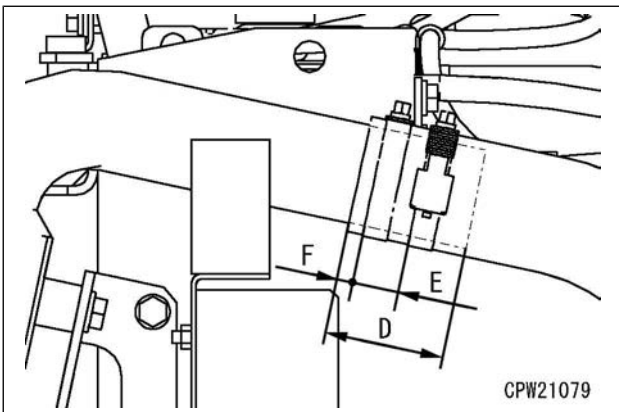
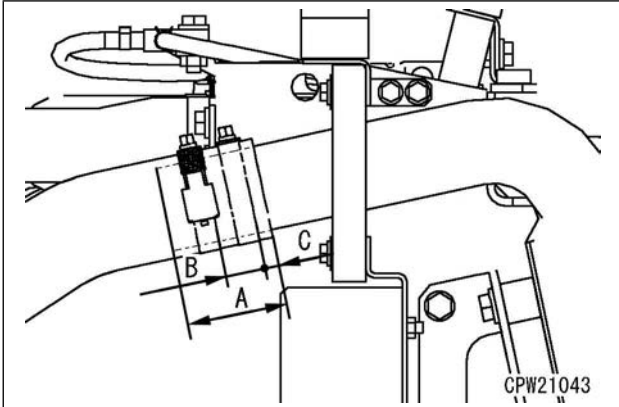

## Disassembly and assembly of KDPF assembly (WA380-A9H0-926-K-00-A)

★ Special tools

Symbol	Part No.	Part name	Necessity	Quantity
A	8	Commercially available	●	1
	9	Commercially available	●	1

⚠ Since temperature of the KDPF and KDOC becomes 500°C or higher, take care not to get burn injury.

⚠ Stop the engine, wait until piping around the engine cools down, then remove the KDPF.

⚠ When cleaning, replacing, or disposing the KDPF or KCSF, use dust mask not to inhale accumulated soot, ashes, mat materials or powders of precious metals inside the KDPF.

⚠ When installing KCSF, be careful about its installed direction.

⚠ Handle the KDPF with care since an impact on it, for instance, dropping it, causes it to damage. And be sure not to use a damaged part.

⚠ Keep record of each KDPF unit to control its service life, and never use a KDPF after its service life has elapsed.

★ Since the V-clamp and band used for the KDPF are made of stainless steel, avoid using an air tool for removal and installation of nuts. Otherwise threaded portions can be damage.

★ When removing a gasket or band, prepare new ones at hand.

### Disassembly (WA380-A9H0-530-K-00-A)

1. Use blocks [1] to support the KDPF assembly at four places so that its inlet body and the KDPF filter assembly are supported.

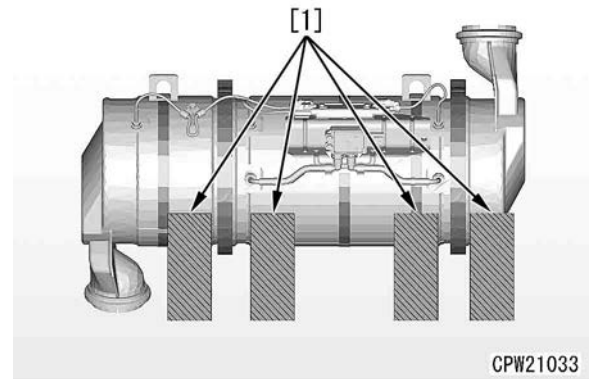

- ★ Prepare blocks [1] based on the shapes shown in the following figure and use wooden blocks so that the inlet flange does not interfere with them.

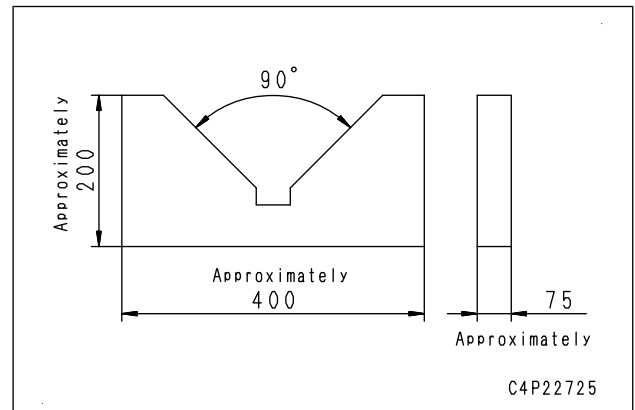

2. Put match marks on the components for setting their inlet and outlet angle at assembly.

- ★ Make match marks on the V-clamp, inlet body, and outlet body, referring to the KDPF filter and the mounting portion of the delta pressure sensor piping.

- ★ It does not matter that the match marks are put slightly shifted, since the angle of KDPF assembly can be adjusted when it is installed.

- Inlet side

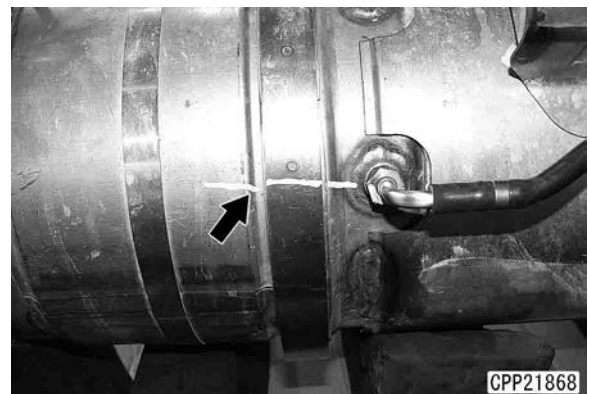

- Outlet side

## 50 Disassembly and assembly

### Power train

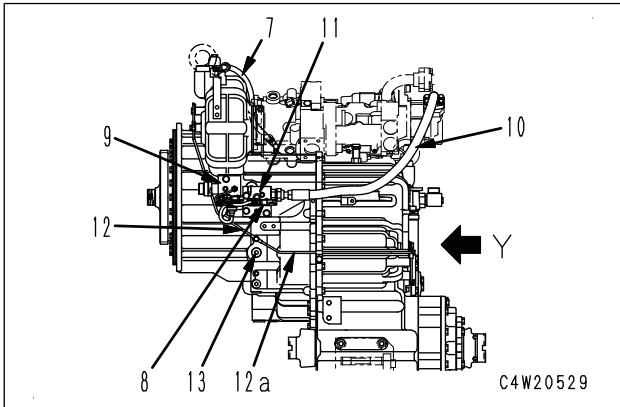

5) Remove adapter (12b).

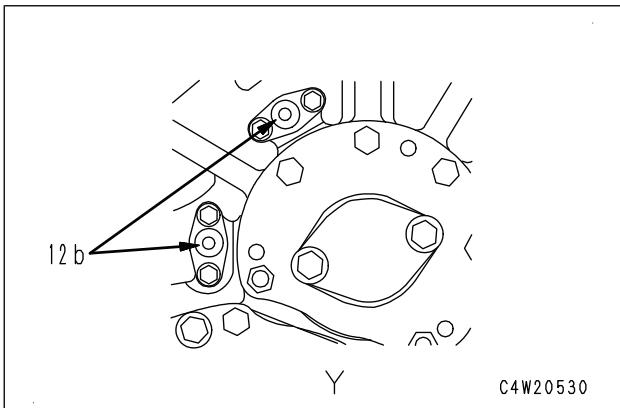

5. Transmission mount, coupling, level gauge, and brake hose

- 1) Remove transmission mounts (14) and (15).
- 2) Remove cover (16).
- 3) Remove level gauge (17).

★ When removing the bolt, lock the upper and lower holders of the level gauge with spanners.

- 4) Remove brake hose (18).

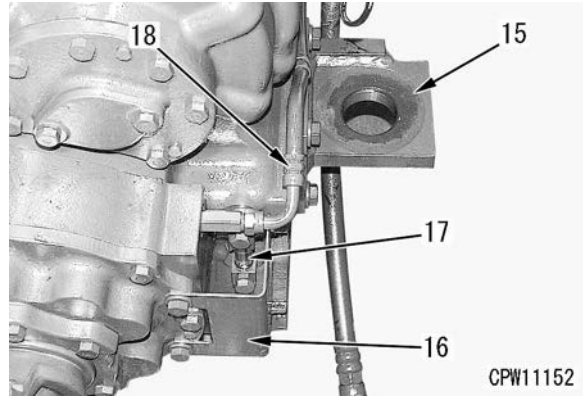
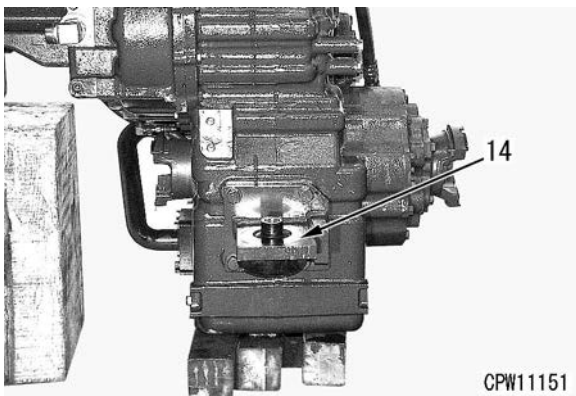

6. Transmission control valve assembly

- 1) Disconnect wiring connectors (60) to (77) and remove harness assembly (19).

- (60): F. PS (F clutch solenoid)
- (61): F. SW (F clutch switch)
- (62): R. PS (R clutch solenoid)
- (63): R. SW (R clutch switch)
- (64): 4. PS (4th clutch solenoid)
- (65): 4. SW (4th clutch switch)
- (66): 1. PS (1st clutch solenoid)
- (67): 1. SW (1st clutch switch)
- (68): 3. PS (3rd clutch solenoid)
- (69): 3. SW (3rd clutch switch)
- (70): 3. PS (2nd clutch solenoid)
- (71): 2. SW (2nd clutch switch)
- (72): PB. PS (Parking brake solenoid)
- (73): PB. SW (Parking brake switch)
- (74): TM. T (Transmission oil temperature sensor)
- (75): REV. OUT (Speed sensor)
- (76): LC. PS (Lockup clutch solenoid)
- (77): REV IN (Transmission input shaft speed sensor)

- 2) Fit eyebolt [3], sling transmission control valve assembly (20), and remove 10 mounting bolts (at portions marked with \*) to remove the assembly.

★ Since bolts \*1 and \*2 are different in length, note their locations.

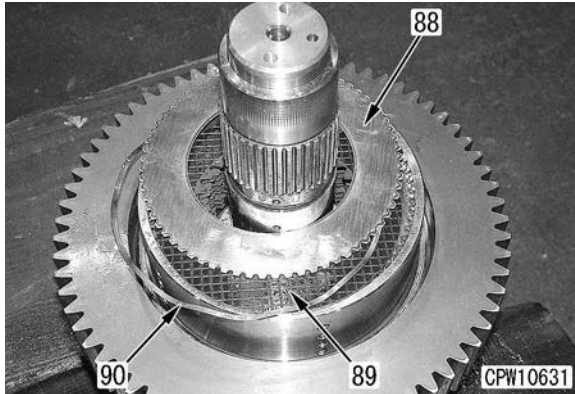

4. End plate

- 1) Install end plate (91).
- 2) By using C-clamp [15] or the like, press end plate (91) to install snap ring (92).

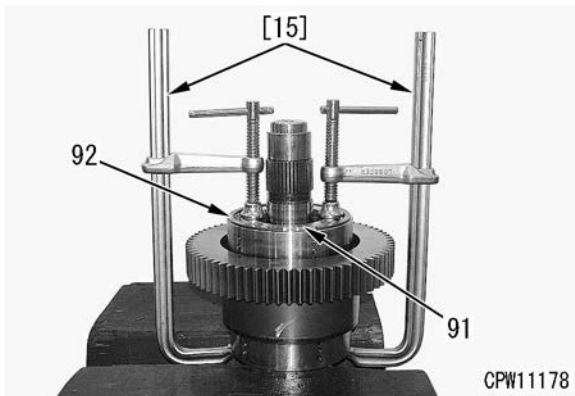

5. 2nd gear

- 1) Install needle bearing (64) to 2nd gear (63), and install the gear while meshing it with internal teeth of the disc.
- ★ When the gear does not mesh with internal teeth of the disc, try to install the gear while rotating it. Do not forcibly press the gear to install.
- 2) Install thrust washer (62).

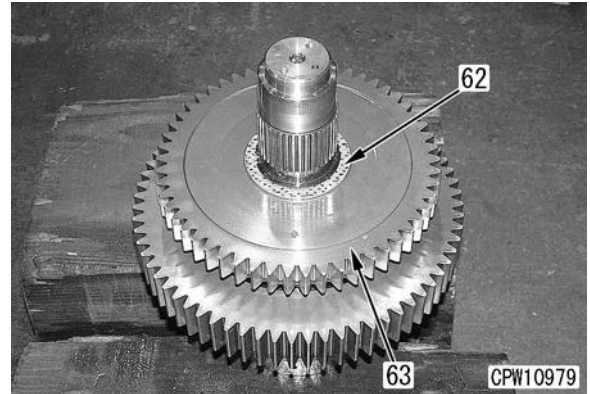
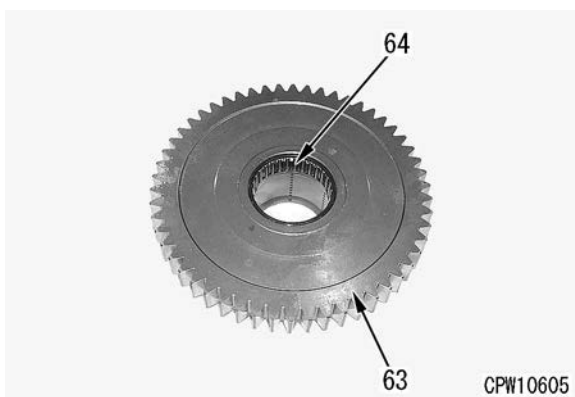

6. Idler gear and bearing

- 1) Install idler gear (60).

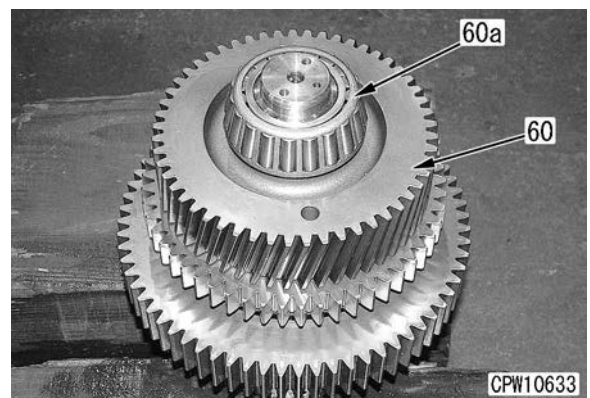

- 2) By using tool D4, press-fit bearing (60a).

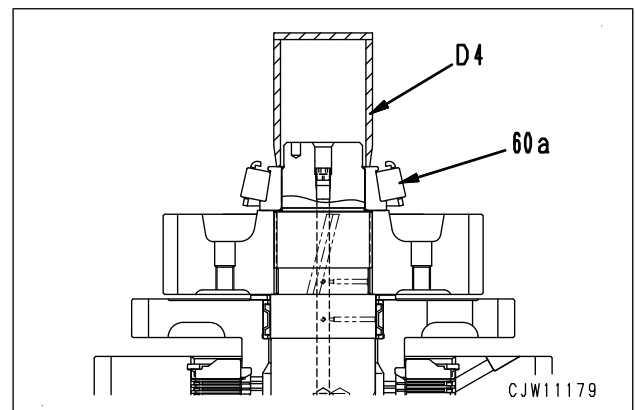

- 3) Check that clearance "e" between idler gear (60) and thrust washer (62) is within the standard range.

- Standard value "e": 0.28 to 0.72 mm

- ★ Use a dial gauge or feeler gauge to measure clearance "e".

## 50 Disassembly and assembly

### Power train

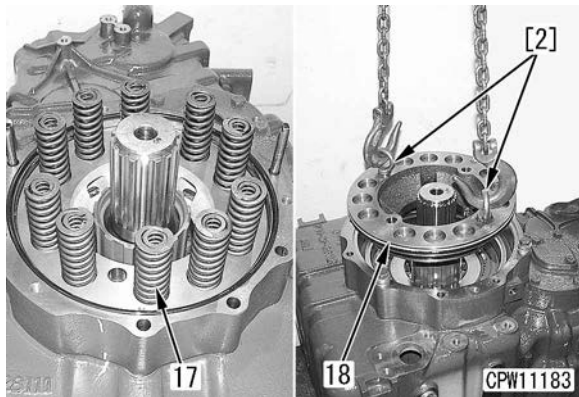

#### 8. Plate, spring and disc

- 1) By using tool J1, remove snap ring (19).

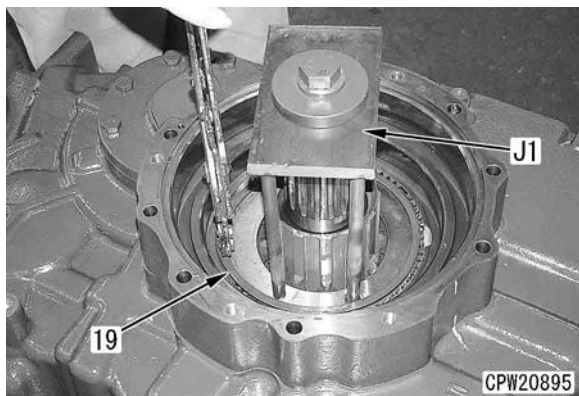

- 2) Remove hub (20).
- 3) Remove plates (21), springs (22) and discs (23).

★ Ten plates, nine springs, and nine discs

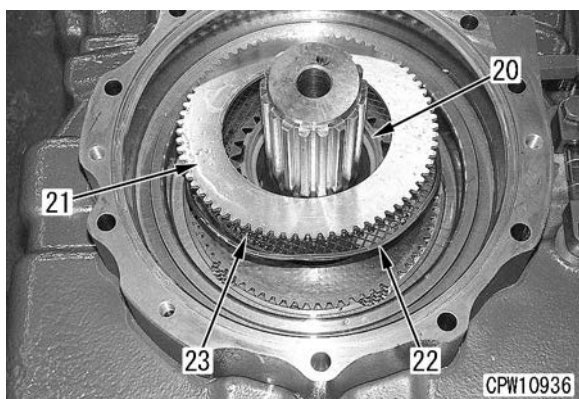

#### 9. Brake housing

- Fit eyebolts [3], and sling and remove brake housing (24).

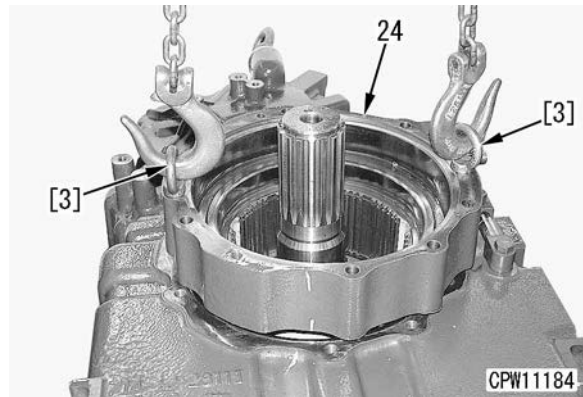

#### 10. Output shaft assembly

- 1) Fit eyebolt [4], and sling and remove output shaft assembly (27).
- 2) Remove gear (28) from output shaft assembly (27).
- 3) Remove bearing (29).

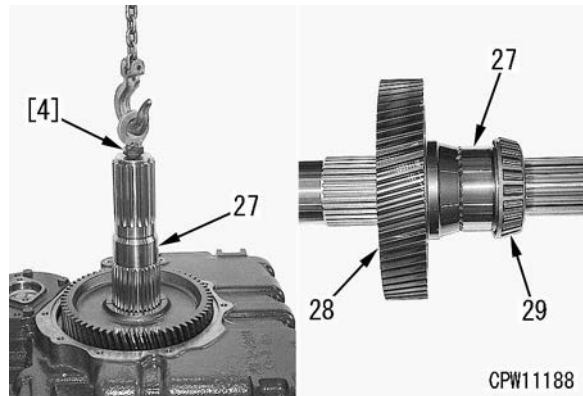

#### 11. Oil guide

- Remove oil guide (30).

#### 12. Outer race and oil seal (rear drive side)

- 1) Remove outer race (31).
- 2) Remove dust seal (32).
- 3) Remove oil seal (33).

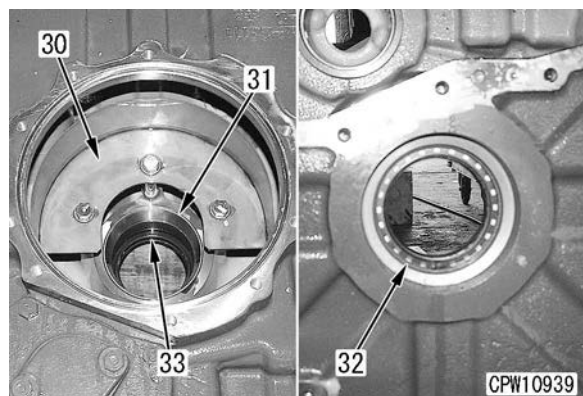

### Assembly (WA380-GJ00-720-K-00-A)

- ★ Clean all parts and check them for dirt or damage before installation.
- ★ Press-fit the outer race and inner race of each bearing until they are seated on the case, cage, shaft or boss.

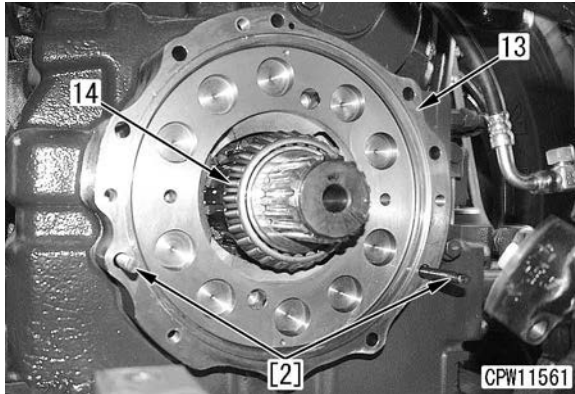

9. Install two bolts [3] to piston (15) and pry them up with bar [4] to remove piston (15).[\*5]

- ★ If the O-ring comes off, the piston falls. Take care.

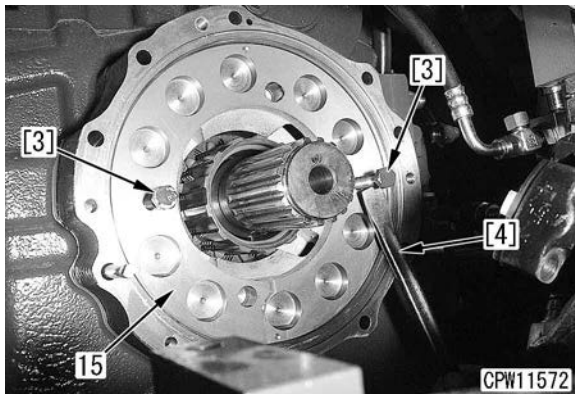

10. By using tool J1, push in the brake discs and plates to remove snap ring (16).

- ★ You can use the yoke mounting bolt and retainer as the holder and bolt of tool J1.

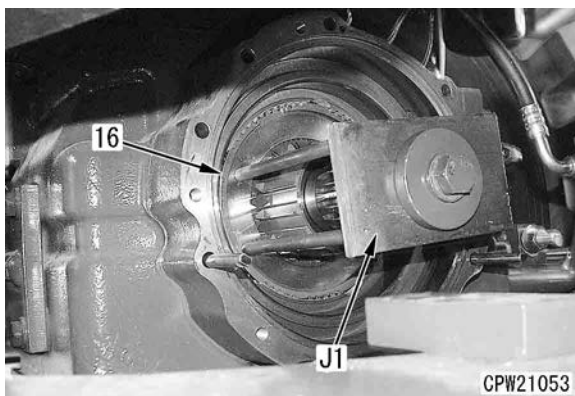

11. Remove hub (17) to remove plates (18), springs (19), and discs (20).[\*6]

- ★ Ten plates, nine springs and nine discs.

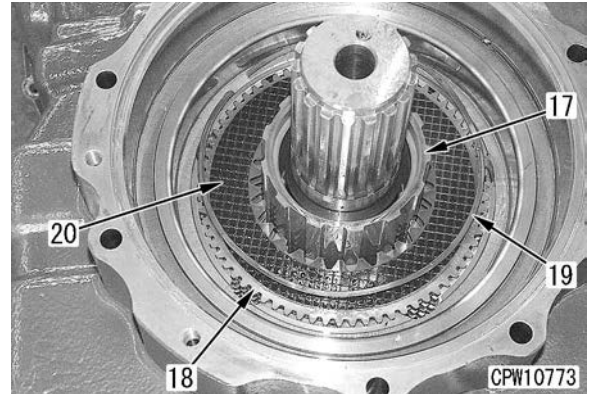

### Installation (WA380-GJ72-720-K-00-A)

- Perform installation in the reverse order to removal.

[\*1]

- ★ When installing drive shaft, check that key of spider cap is completely fitted to key groove of the mating yoke before tightening bolt.

 **Mounting bolt:**  
98 to 123 Nm {10 to 12.5 kgm}

[\*2]

 **Coupling mounting bolt:**  
Adhesive (LT-2)

 **Coupling mounting bolt:**  
490 to 608 Nm {50 to 62 kgm}

[\*3]

- ★ Install shims to original position.

 **Mounting bolt:**  
98 to 123 Nm {10 to 12.5 kgm}

[\*4]

 **Brake cover mounting joint:**  
98 to 123 Nm {10 to 12.5 kgm}

[\*5]

 **O-ring of piston:**  
Grease (G2-L1)

- ★ When installing the piston, align march mark (a) of the piston to match mark (b) of the housing.

## 50 Disassembly and assembly

### Hydraulic system

- Steering cylinder assembly
- 1) Set cylinder head and piston rod assembly (3) on tool U1.
- 2) By using tool U3, remove nut (5).
  - ★ Width across flats of nut: 50 mm
- 3) Remove piston (6), and remove cylinder head assembly (2).

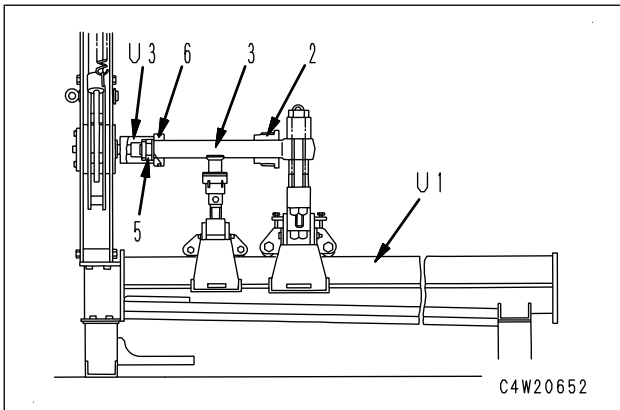

- Lift cylinder assembly and bucket cylinder assembly
- 1) Set cylinder head and piston rod assembly (3) on tool U1.

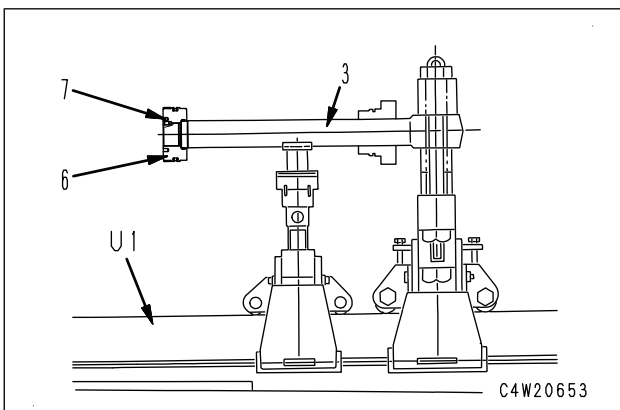

- 2) Remove lock screw (7) of the piston assembly.

★ Screw size: M12 x Pitch size 1.75

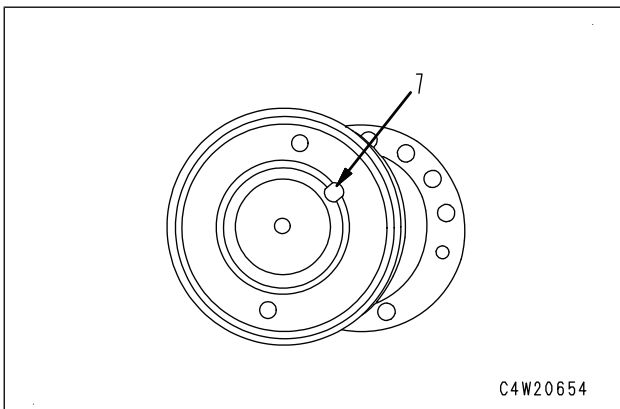

- ★ If screw (7) is punched securely and hard to remove, tighten it further once. Then tap its threaded portion and remove the screw.

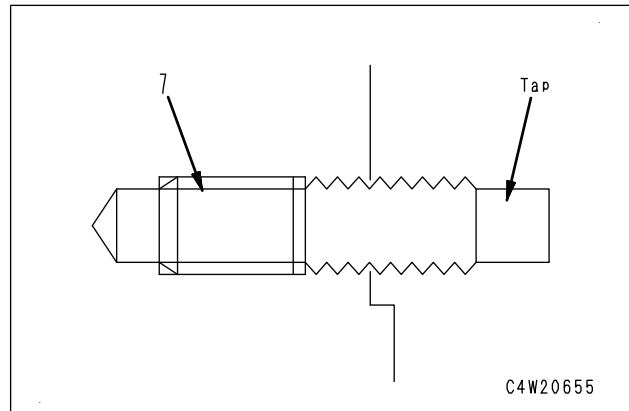

- 3) By using tool U4, remove piston assembly (6).

- ★ When tool U4 is not used, use drilled holes ( $\phi 10$  in two places) to loosen the piston assembly.

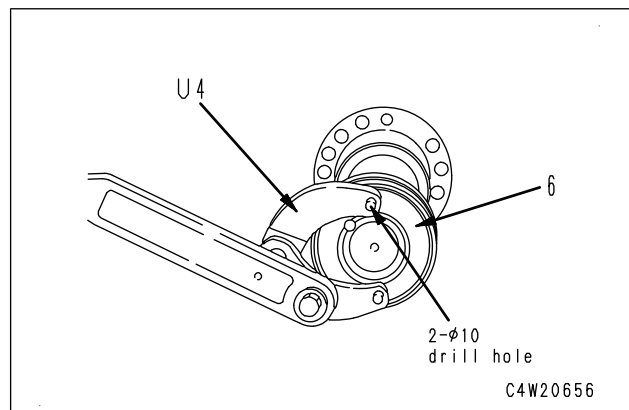

- 4) Remove cylinder head assembly (2).

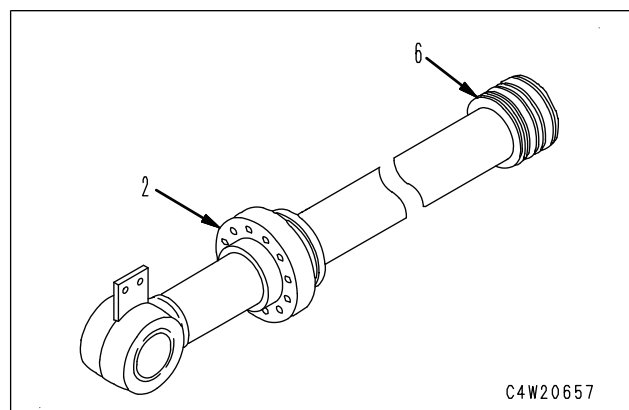

- 3. Disassembly of piston assembly

- Steering cylinder assembly
- Remove wear ring (8) and piston ring (9) from piston (6).

## Removal and installation of operator's seat assembly (WA380-K2Q0-924-K-00-A)

- ⚠ Stop the machine on a level ground and apply the parking brake.
- ⚠ Set the lock bar to the front and rear frames to lock them and chock wheels.
- ⚠ Lower the work equipment to the ground.
- ⚠ Stop the engine and turn the battery disconnect switch to the OFF position and remove the key.

### Removal (WA380-K2Q0-520-K-00-A)

#### Upper seat assembly

1. Remove wiring clamp (1) and remove connector (2).

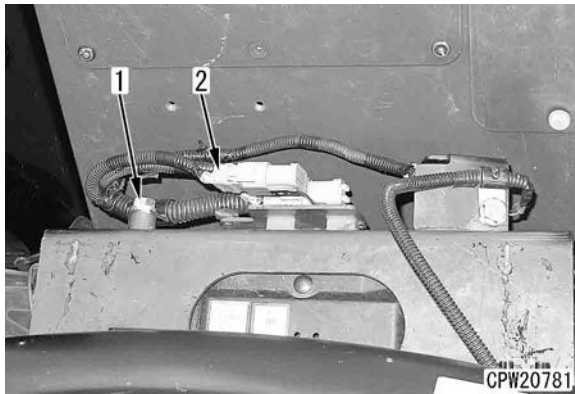

2. Remove wiring clamp (3) and remove wiring connector (4).

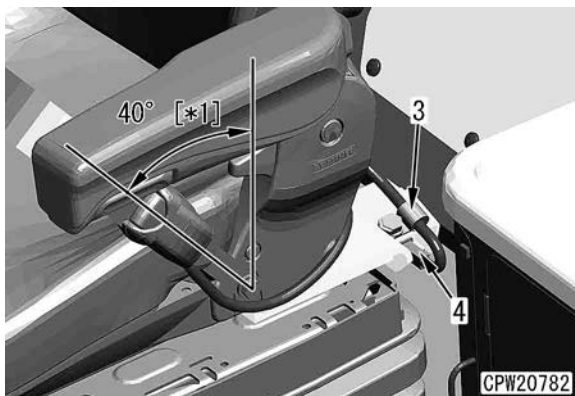

3. Remove four upper seat assembly mounting bolts (5).

- ★ Upper seat assembly mounting bolt (5):  
Hexagonal socket head bolt (M8)

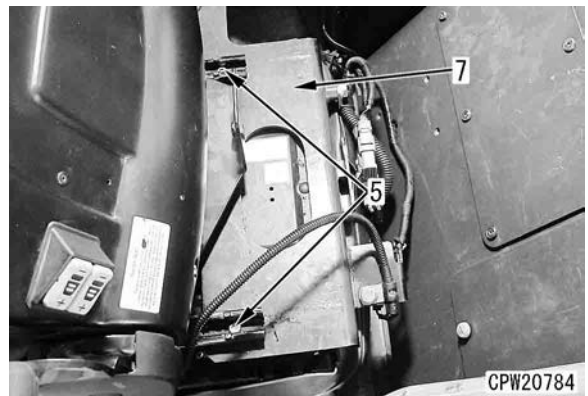

4. Remove upper seat assembly (6).

- ★ Since a crane is not usable in the ROPS cab, make up a team with two persons when removing upper seat assembly (6).

 **Upper seat assembly (6):**  
30 kg

- ★ Remove four upper seat assembly mounting bolts (5), then right console base (7) will be detached. Take care of it since it inclines to the right console side.

#### Suspension assembly

1. Remove four mounting bolts (8) of suspension assembly (9), and remove it.

- ★ Since a crane is not usable in ROPS cab, make up a team with two persons when removing suspension assembly (9).

 **Suspension assembly (9):**  
25 kg

Transmission (WA380-CF00-034-K-00-A)

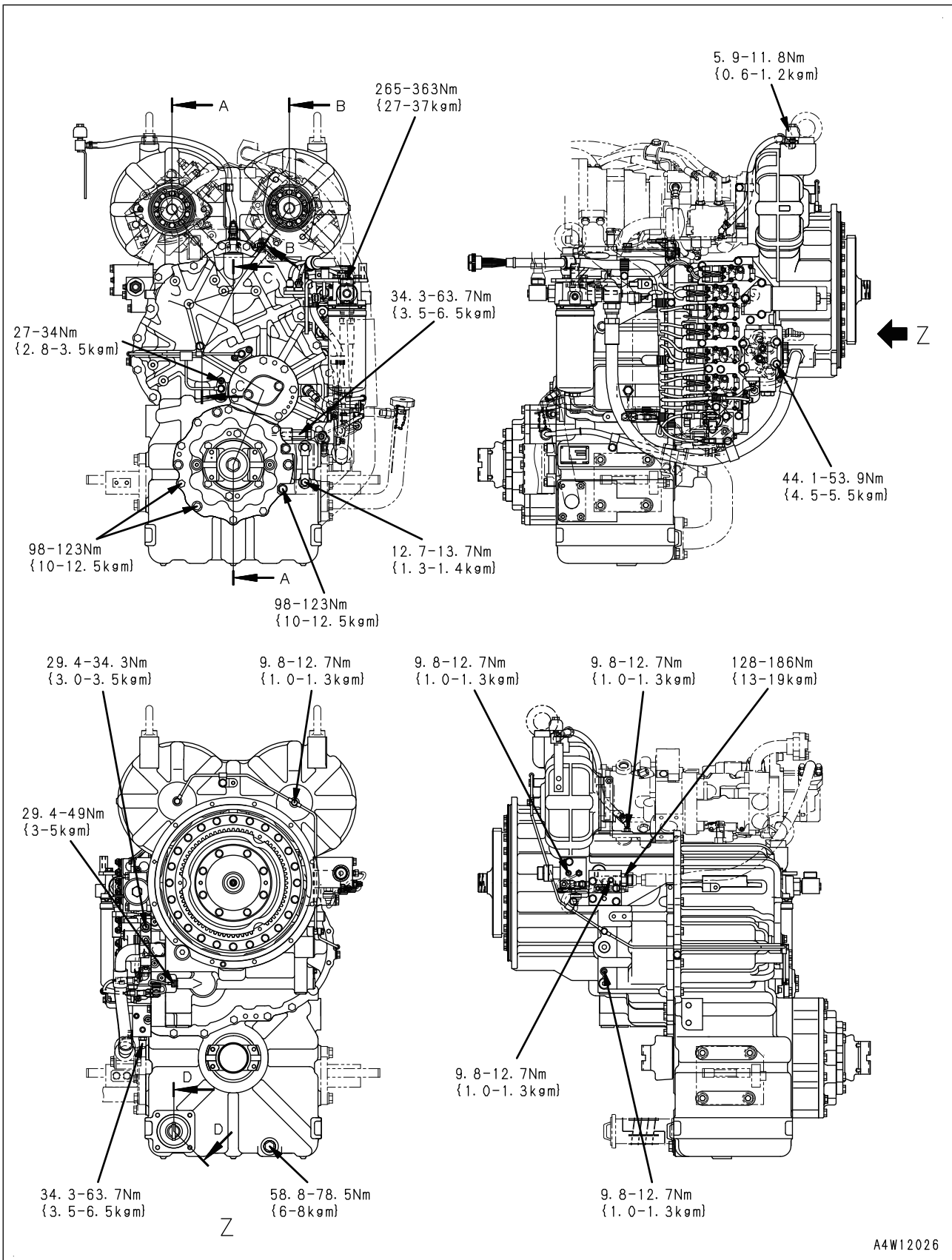

A4W12026

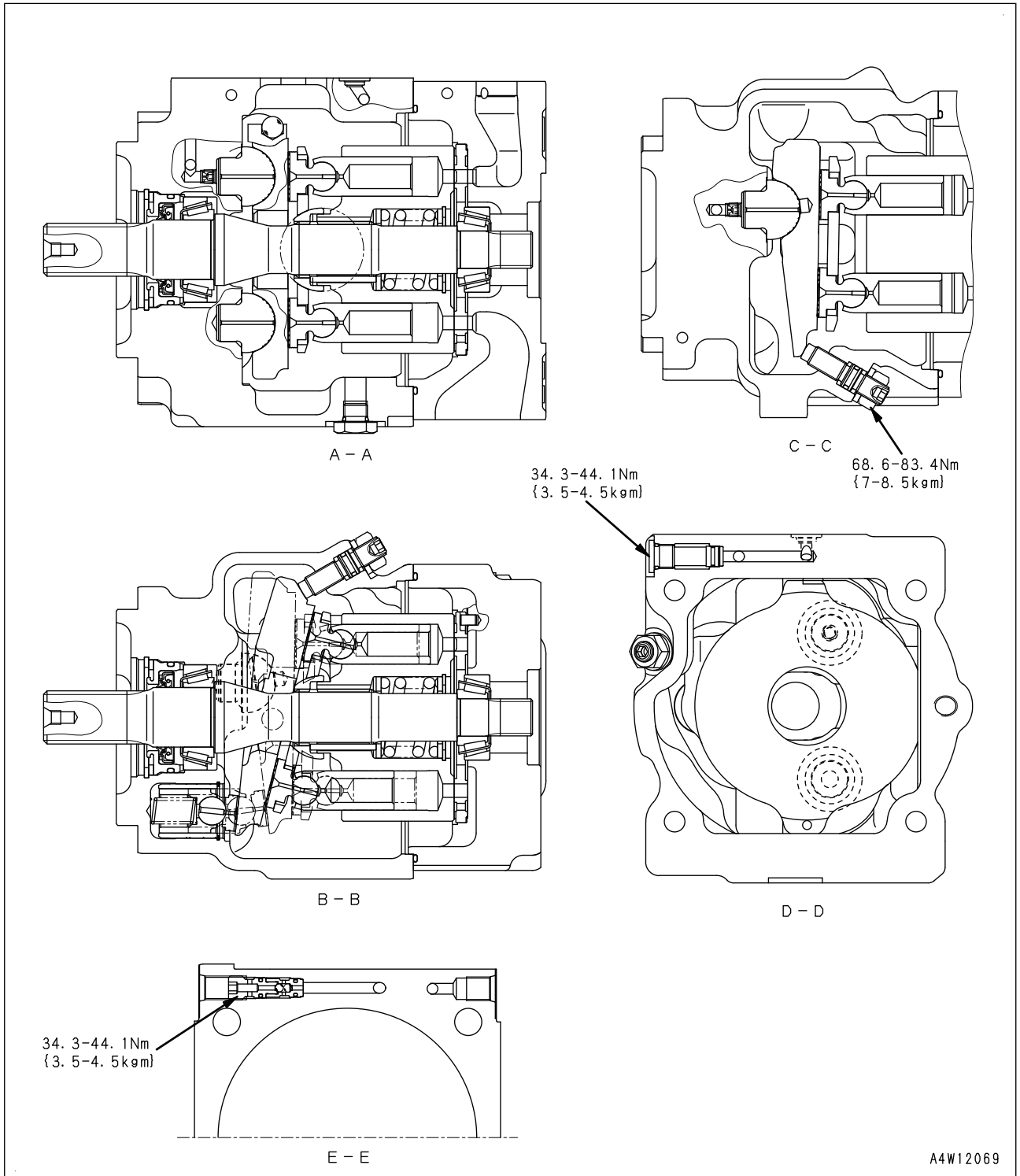

Servo valve (WA380-C2B0-034-K-00-A)

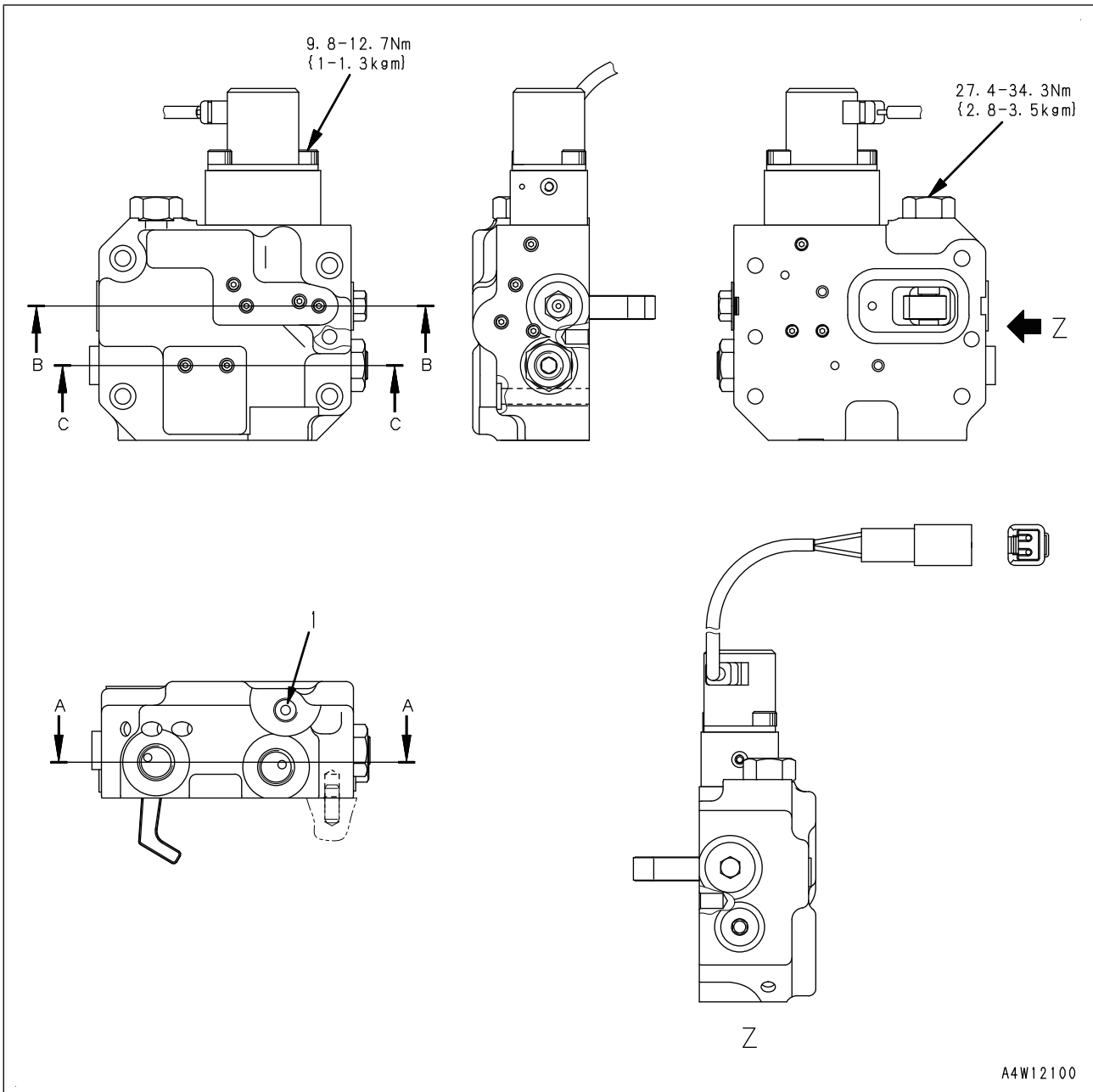

- 9. Air conditioner controller
- 10. Air conditioner unit
- 11. Recirculation air filter
- 12. Fresh air filter
- 13. Machine monitor
- 14. Sunlight sensor

**Specification** (WA500-K500-030-K-00-A)

Refrigerant	R134a
Refrigerant refill amount (g)	1,050 ± 50

- A. Vents for front glass defroster
- B. Vents for face
- C. Vents for foot
- D. Recirculation air inlet
- E. Fresh air inlet

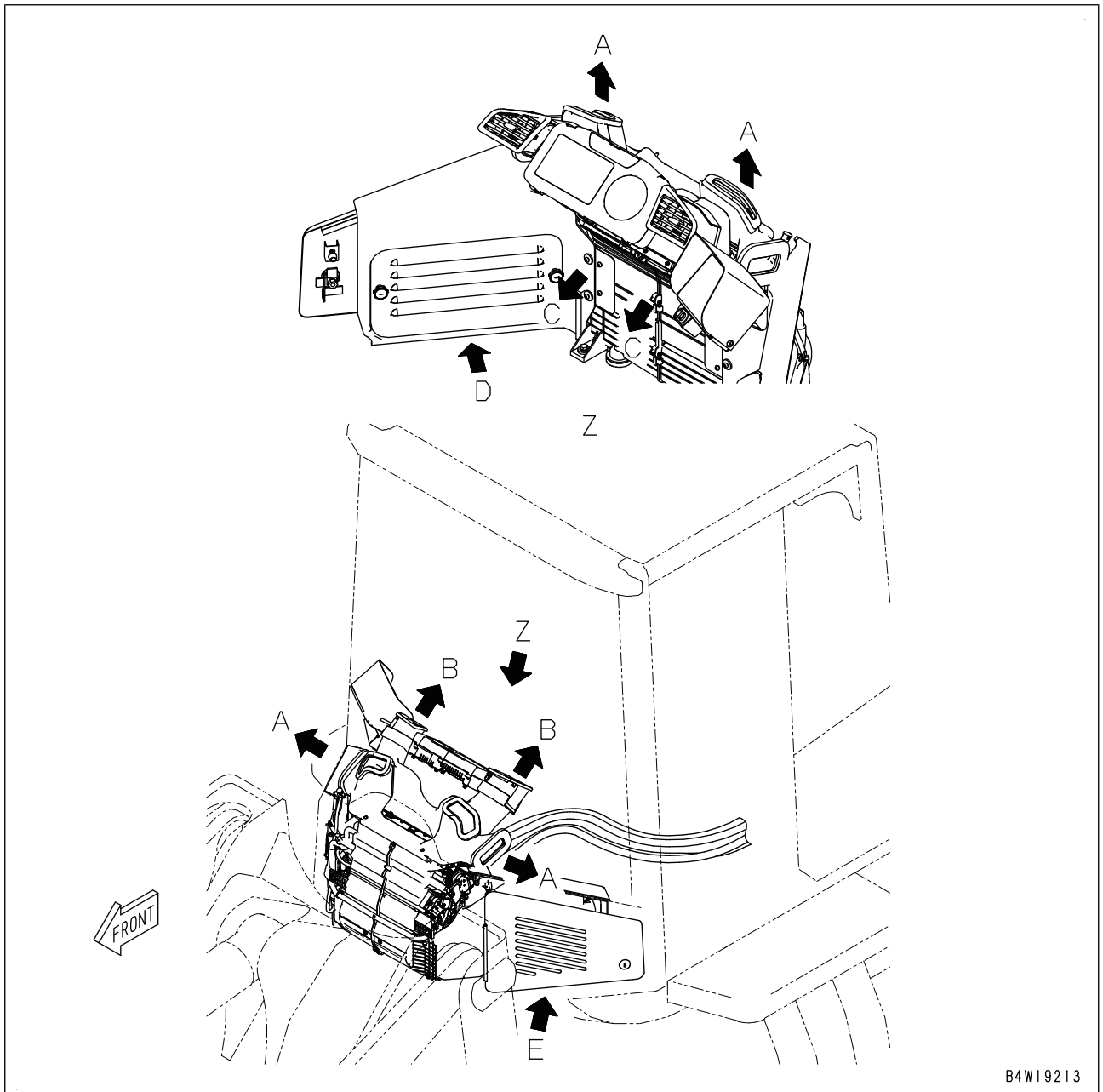

B4W19213

- Operation of air conditioner controller
  1. The monitor controller gets input from air conditioner control switches on the switch panel through LIN communication. The air conditioner controller communicates with the monitor controller through CAN communication to receive input from air conditioner control switches. The air conditioner controller uses the information to control the air conditioner.
  2. The air conditioner controller controls three servomotors located inside the air conditioner unit in order to perform temperature control (air mix), vent (mode) changeover, and FRESH/RECIRC air changeover.
  3. The air conditioner controller controls ON/OFF of the blower OFF relay (switch for blowing air) and compressor clutch relay (switch for running the compressor).
  4. The air conditioner controller controls the air flow volume by using the blower amplifier.
    - ★ The blower amplifier has a fuse for temperature in it.
  5. The air conditioner controller determines the evaporator temperature using the evaporator temperature sensor.
  6. In order to prevent freezing of the evaporator, the air conditioner controller controls the compressor by turning the compressor clutch relay ON and OFF.
    - ★ When the dual pressure switch detects an abnormal pressure (i.e., it turns off), the compressor stop running because the compressor clutch relay disengages without through the air conditioner controller.
  7. When the air conditioner is on AUTO mode, it adjust the room temperature to the set temperature based on the data from the sunlight sensor, inner sensor (inside air temperature sensor), and outer sensor (outside air temperature sensor).
  8. The air conditioner controller has a self-diagnosis function and informs the machine monitor of an error if it detects the error. Then failure code [879\*\*\*] is displayed on the electrical system failure record screen of the machine monitor.

**Failure code list related to air conditioner** (WA380-K500-441-K-00-A)

Failure code	Failure (Displayed on screen)	Applicable component	Action level	History category	Remarks
879AKA	A/C Inner Sensor Open Circuit	MON	—	Electrical system	For each connector of sensor, see "Parts and connectors layout".
879AKB	A/C Inner Sensor Short Circuit	MON	—	Electrical system	
879BKA	A/C Outer Sensor Open Circuit	MON	—	Electrical system	For each connector of sensor, see "Parts and connectors layout".
879BKB	A/C Outer Sensor Short Circuit	MON	—	Electrical system	
879CKA	Ventilating Sensor Open Circuit	MON	—	Electrical system	For each connector of sensor, see "Parts and connectors layout".
879CKB	Ventilating Sensor Short Circuit	MON	—	Electrical system	
879DKZ	Sunlight Sensor Open or Short Circuit	MON	—	Electrical system	For each connector of sensor, see "Parts and connectors layout".
879EMC	Ventilation Damper Abnormality	MON	L01	Electrical system	
879FMC	Air Mix Damper Abnormality	MON	L01	Electrical system	
DAZ9KQ	A/C Model Selection Abnormality	MON	—	Electrical system	See Chapter 40, "Troubleshooting by failure code"
DAZQKR	CAN2 Discon (Aircon ECU)	MON	L01	Electrical system	

- ★ The "air conditioner inner sensor" means the inside (air) temperature sensor.
- ★ The "air conditioner outer sensor" means the outside (air) temperature sensor.
- ★ The "ventilating sensor" means the evaporator temperature sensor (frost sensor).
- ★ The "ventilation damper" means the vent (mode) changeover damper (door).
- ★ The "air mix damper" means the temperature adjustment (air mix) damper (door).
- ★ Troubleshooting for the troubles which do not display failure codes are listed below the failure code [879FMC].
  - "Troubleshooting for power supply and CAN communication system (Air conditioner does not operate)"
  - "Troubleshooting for compressor and refrigerant system (Air is not cooled)"
  - "Troubleshooting for blower motor system (No air comes out or air flow is abnormal)"
  - "Troubleshooting for FRESH/RECIRC air changeover"

# 80 Appendix

## A-1 Troubleshooting for power supply and CAN communication system (Air conditioner does not operate)

### Circuit diagram related to power supply and CAN communication

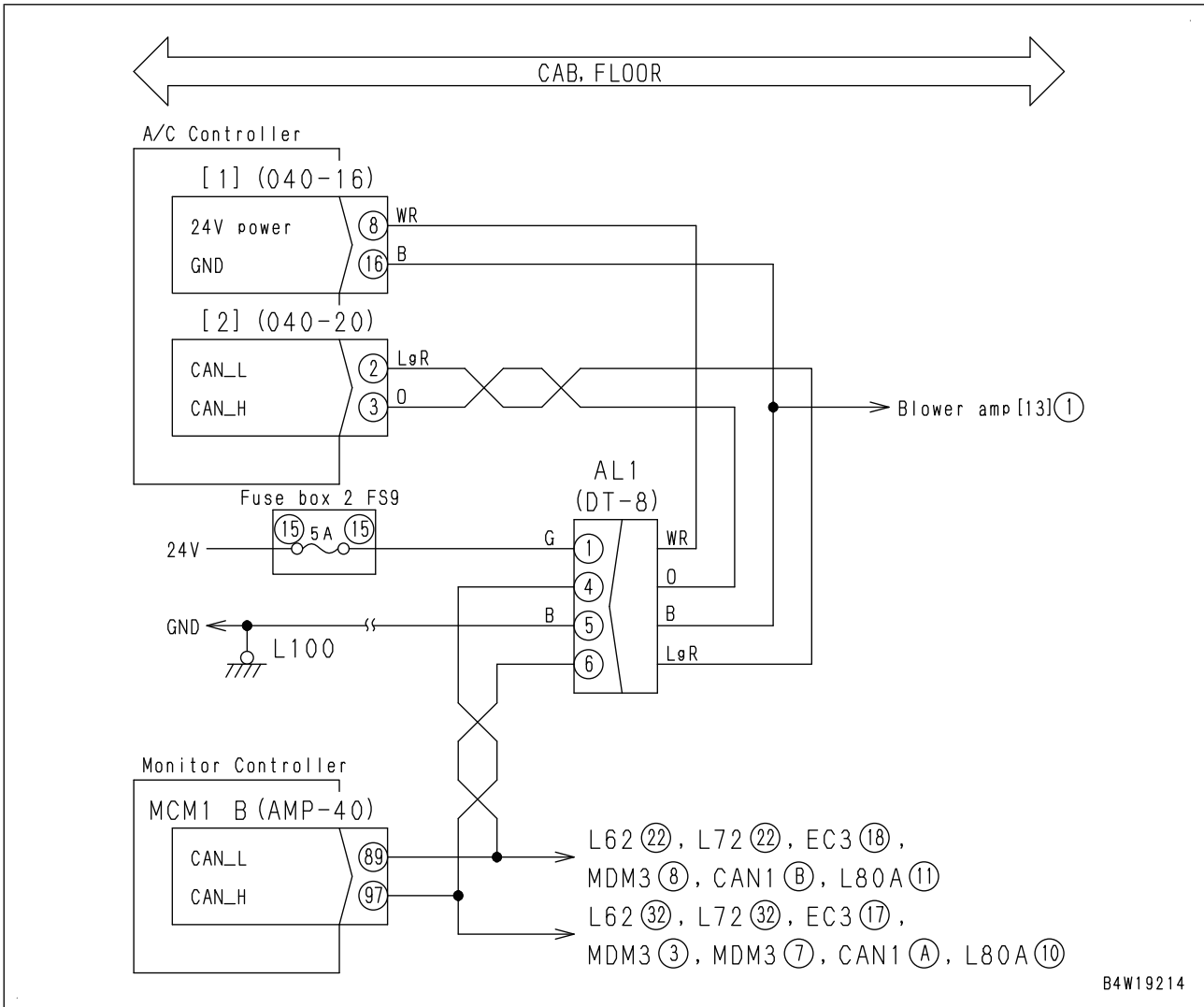

CLICK HERE TO **DOWNLOAD** THE COMPLETE MANUAL

- Thank you very much for reading the preview of the manual.
- You can download the complete manual from: [www.heydownloads.com](http://www.heydownloads.com) by clicking the link below



- Please note: If there is no response to CLICKING the link, please download this PDF first and then click on it.

CLICK HERE TO **DOWNLOAD** THE COMPLETE MANUAL