

SHOP MANUAL

KOMATSU WA320-5

Machine model	Serial number
WA320-5	C30001 and up

- This shop manual may contain attachments and optional equipment that are not available in your area. Please consult your local Komatsu distributor for those items you may require. Materials and specifications are subject to change without notice.
- WA320-5 mounts the SAA6D102E-2-A engine.
For details of the engine, see the 102 Series Engine Shop Manual.

CLICK HERE TO **DOWNLOAD** THE COMPLETE MANUAL

- Thank you very much for reading the preview of the manual.
- You can download the complete manual from: www.heydownloads.com by clicking the link below



- Please note: If there is no response to CLICKING the link, please download this PDF first and then click on it.

CLICK HERE TO **DOWNLOAD** THE COMPLETE MANUAL

HOISTING INSTRUCTIONS

HOISTING

! Heavy parts (25 kg or more) must be lifted with a hoist, etc. In the **DISASSEMBLY AND ASSEMBLY** section, every part weighing 25 kg or more is indicated clearly with the symbol 

- If a part cannot be smoothly removed from the machine by hoisting, the following checks should be made:
 - 1) Check for removal of all bolts fastening the part to the relative parts.
 - 2) Check for existence of another part causing interference with the part to be removed.

WIRE ROPES

- 1) Use adequate ropes depending on the weight of parts to be hoisted, referring to the table below:

Wire ropes
(Standard "Z" or "S" twist ropes
without galvanizing)

Rope diameter	Allowable load	
	kN	tons
mm		
10	9.8	1.0
11.5	13.7	1.4
12.5	15.7	1.6
14	21.6	2.2
16	27.5	2.8
18	35.3	3.6
20	43.1	4.4
22.4	54.9	5.6
30	98.1	10.0
40	176.5	18.0
50	274.6	28.0
60	392.2	40.0

- ★ The allowable load value is estimated to be one-sixth or one-seventh of the breaking strength of the rope used.
- 2) Sling wire ropes from the middle portion of the hook.

Slinging near the edge of the hook may cause the rope to slip off the hook during hoisting, and a serious accident can result. Hooks have maximum strength at the middle portion.

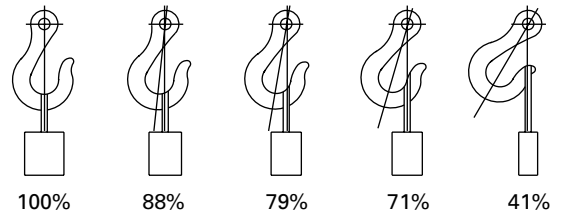

SAD00479

- 3) Do not sling a heavy load with one rope alone, but sling with two or more ropes symmetrically wound onto the load.

! Slinging with one rope may cause turning of the load during hoisting, untwisting of the rope, or slipping of the rope from its original winding position on the load, which can result in a dangerous accident.

- 4) Do not sling a heavy load with ropes forming a wide hanging angle from the hook.

When hoisting a load with two or more ropes, the force subjected to each rope will increase with the hanging angles. The table below shows the variation of allowable load kN {kg} when hoisting is made with two ropes, each of which is allowed to sling up to 9.8 kN {1000 kg} vertically, at various hanging angles.

When two ropes sling a load vertically, up to 19.6 kN {2000 kg} of total weight can be suspended. This weight becomes 9.8 kN {1000 kg} when two ropes make a 120° hanging angle. On the other hand, two ropes are subjected to an excessive force as large as 39.2 kN {4000 kg} if they sling a 19.6 kN {2000 kg} load at a lifting angle of 150°.

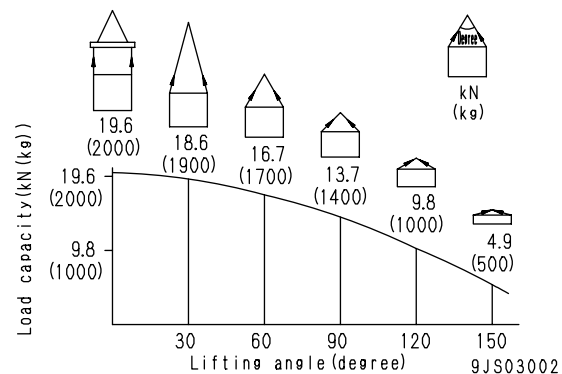

9JS03002

Millimeters to Inches

1 mm = 0.03937 in

	0	1	2	3	4	5	6	7	8	9
0	0	0.039	0.079	0.118	0.157	0.197	0.236	0.276	0.315	0.354
10	0.394	0.433	0.472	0.512	0.551	0.591	0.630	0.669	0.709	0.748
20	0.787	0.827	0.866	0.906	0.945	0.984	1.024	1.063	1.102	1.142
30	1.181	1.220	1.260	1.299	1.339	1.378	1.417	1.457	1.496	1.536
40	1.575	1.614	1.654	1.693	1.732	1.772	1.811	1.850	1.890	1.929
50	1.969	2.008	2.047	2.087	2.126	2.165	2.205	2.244	2.283	2.323
60	2.362	2.402	2.441	2.480	2.520	2.559	2.598	2.638	2.677	2.717
70	2.756	2.795	2.835	2.874	2.913	2.953	2.992	3.032	3.071	3.110
80	3.150	3.189	3.228	3.268	3.307	3.346	3.386	3.425	3.465	3.504
90	3.543	3.583	3.622	3.661	3.701	3.740	3.780	3.819	3.858	3.898

Kilogram to Pound

1 kg = 2.2046 lb

	0	1	2	3	4	5	6	7	8	9
0	0	2.20	4.41	6.61	8.82	11.02	13.23	15.43	17.64	19.84
10	22.05	24.25	26.46	28.66	30.86	33.07	35.27	37.48	39.68	41.89
20	44.09	46.30	48.50	50.71	51.91	55.12	57.32	59.53	61.73	63.93
30	66.14	68.34	70.55	72.75	74.96	77.16	79.37	81.57	83.78	85.98
40	88.18	90.39	92.59	94.80	97.00	99.21	101.41	103.62	105.82	108.03
50	110.23	112.44	114.64	116.85	119.05	121.25	123.46	125.66	127.87	130.07
60	132.28	134.48	136.69	138.89	141.10	143.30	145.51	147.71	149.91	152.12
70	154.32	156.53	158.73	160.94	163.14	165.35	167.55	169.76	171.96	174.17
80	176.37	178.57	180.78	182.98	185.19	187.39	189.60	191.80	194.01	196.21
90	198.42	200.62	202.83	205.03	207.24	209.44	211.64	213.85	216.05	218.26

		Machine model		WA320-5
		Serial No.		C30001 and up
Steering control	Type			Articulated steering
	Control			Hydraulic control
Hydraulic system	Hydraulic pump	Steering pump		
		• Type		Gear type
		• Delivery	ℓ / min	167
		Work equipment pump		
	• Type		Gear type	
	• Delivery	ℓ / min	58	
	Brake and cooling fan pump			
	• Type		Gear type	
	• Delivery	ℓ / min	31	
	Transfer lubrication pump			
	• Type		Gear type	
	• Delivery	ℓ / min	22	
	Cylinder	Steering cylinder	Type	
Cylinder inner diameter			mm	70
Piston rod diameter			mm	40
Stroke			mm	453
Max. length between pins			mm	1,271
Min. length between pins		mm	818	
Lift cylinder		Type		Reciprocating piston type
		Cylinder inner diameter	mm	140
		Piston rod diameter	mm	75
		Stroke	mm	740
		Max. length between pins	mm	1,969
Min. length between pins		mm	1,229	
Bucket cylinder		Type		Reciprocating piston type
		Cylinder inner diameter	mm	160
		Piston rod diameter	mm	80
	Stroke	mm	532	
	Max. length between pins	mm	1,559	
Min. length between pins	mm	1,027		

Serial No. 60676 and up

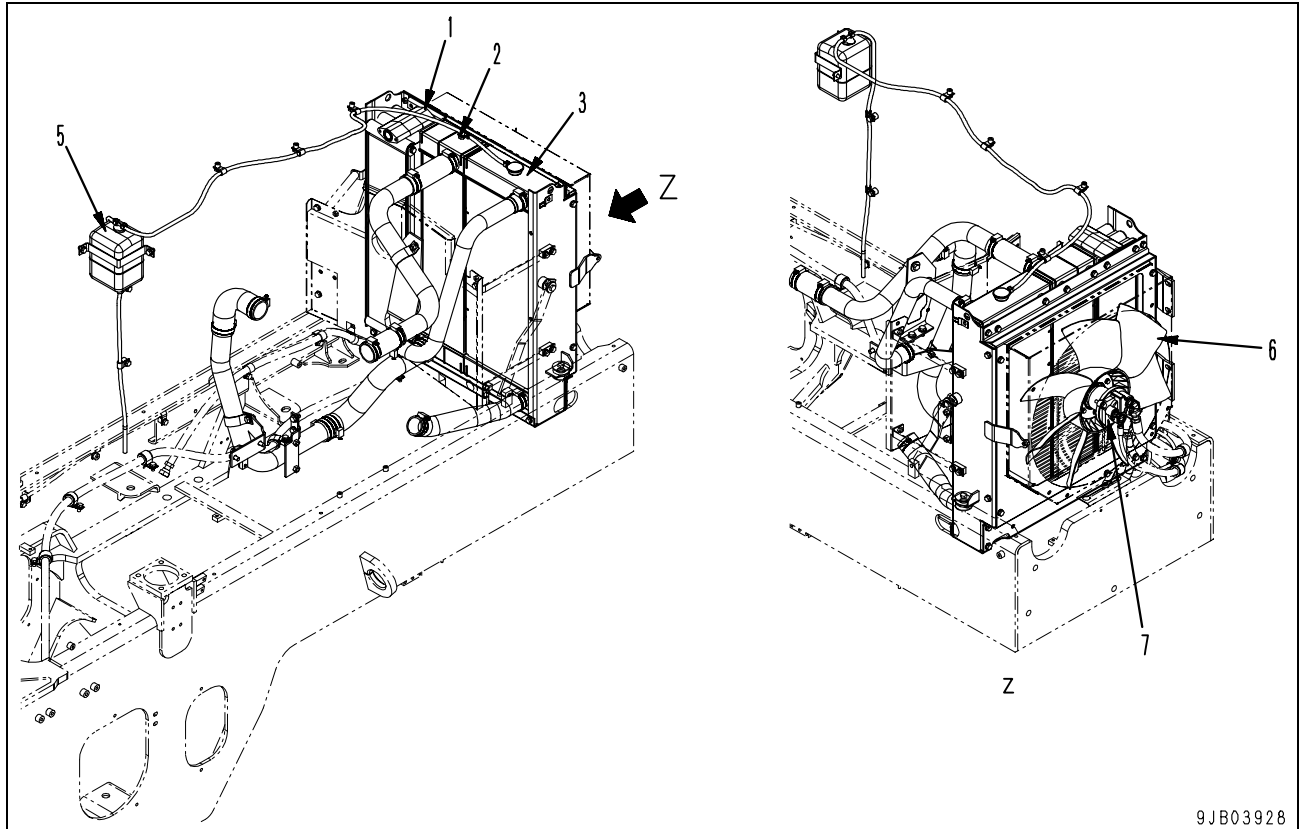

9JB03928

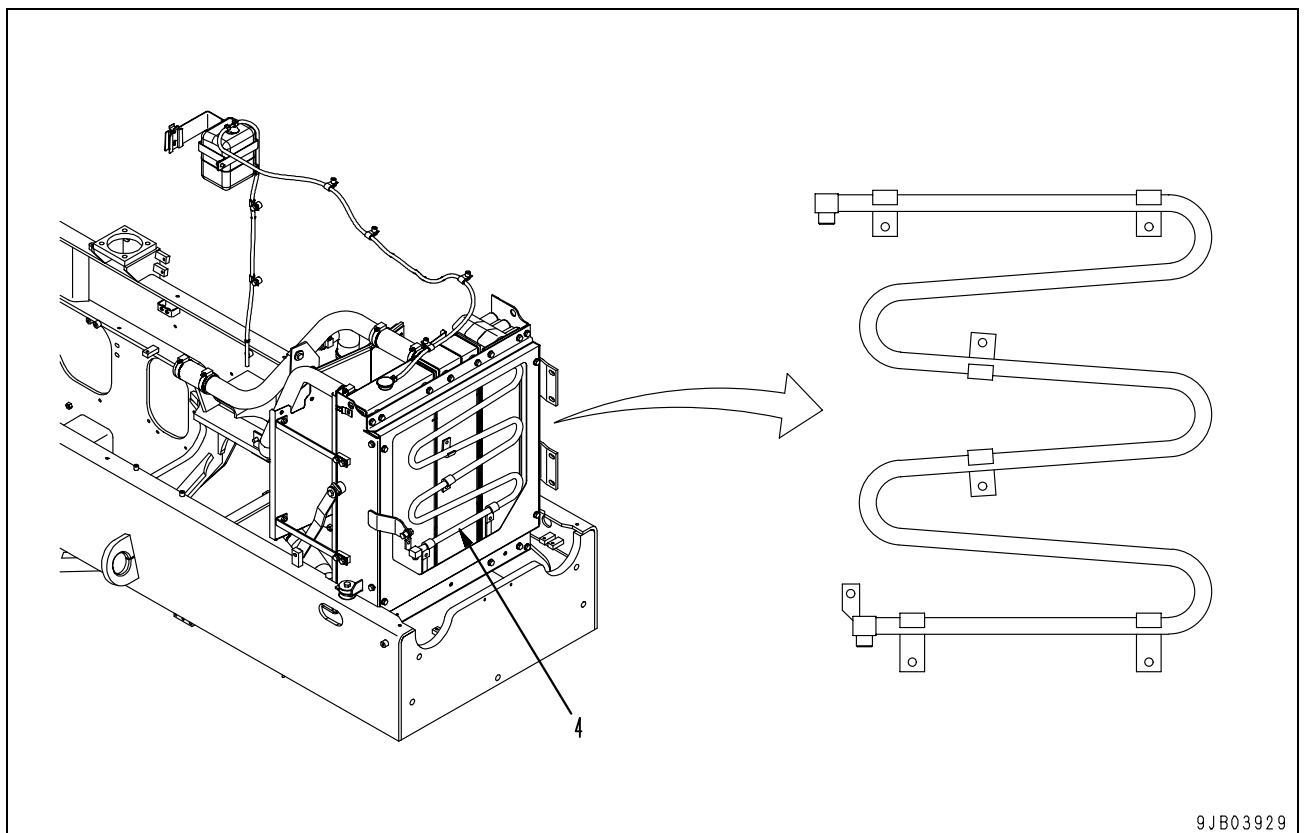

9JB03929

Operation

- Port **A** is connected to the high-pressure circuit of the HST pump and ports **C** and **D** are connected to the low-pressure circuit of the HST pump.
The oil fills chamber **B** through the orifice of main piston (5).
Pilot poppet (7) is seated on valve seat (6).

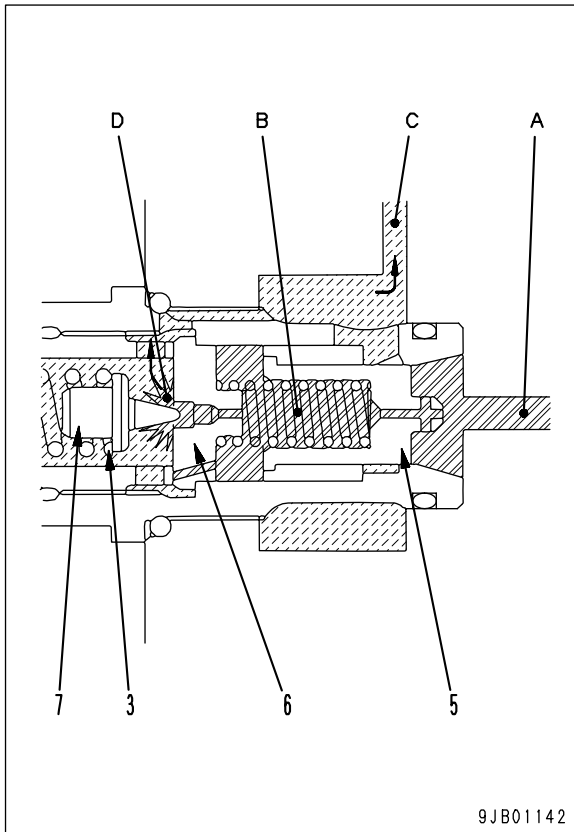

- If the oil pressure in port **A** and chamber **B** reaches the set pressure of poppet spring (3), pilot poppet (7) opens and the oil in chamber **B** flows through chamber **D** to port **C**, and the oil pressure in chamber **B** lowers consequently.
If the oil pressure in chamber **B** lowers, a pressure difference is made between port **A** and chamber **B** by the orifice of main piston (5). As a result, main piston (5) is pushed open and the oil in port **A** flows into port **C** to relieve the abnormal pressure.

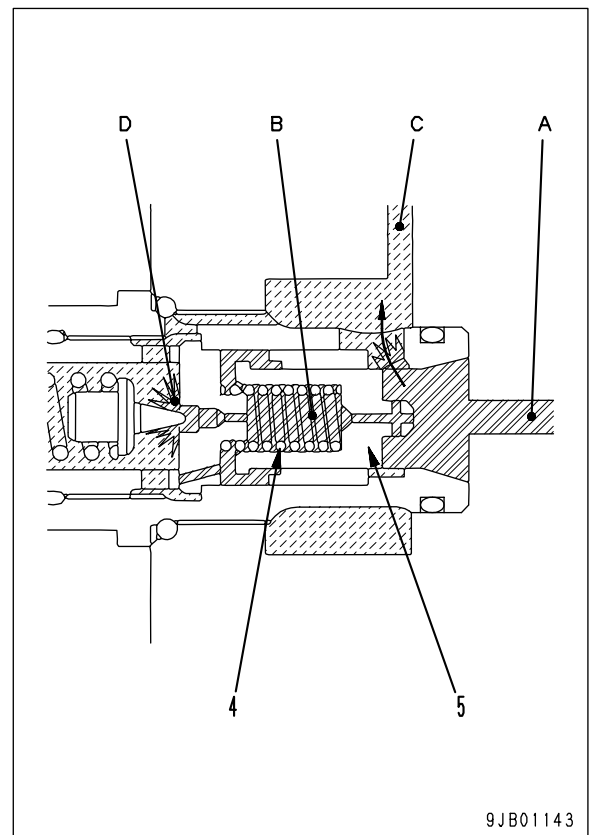

- The set pressure can be adjusted by increasing or decreasing the tension of poppet spring (3). To adjust the set pressure, remove the nut and loosen the locknut. If the adjustment screw is tightened, the set pressure is heightened. If the former is loosened, the latter is lowered.
- If the oil pressure in port **A** lowers below that in port **C**, check spring (4) pushes back main piston (5) and the oil in port **C** flows through chamber **D** into port **A** so that the quantity of the oil in port **A** will not become insufficient.

FORWARD-REVERSE SHUTTLE VALVE

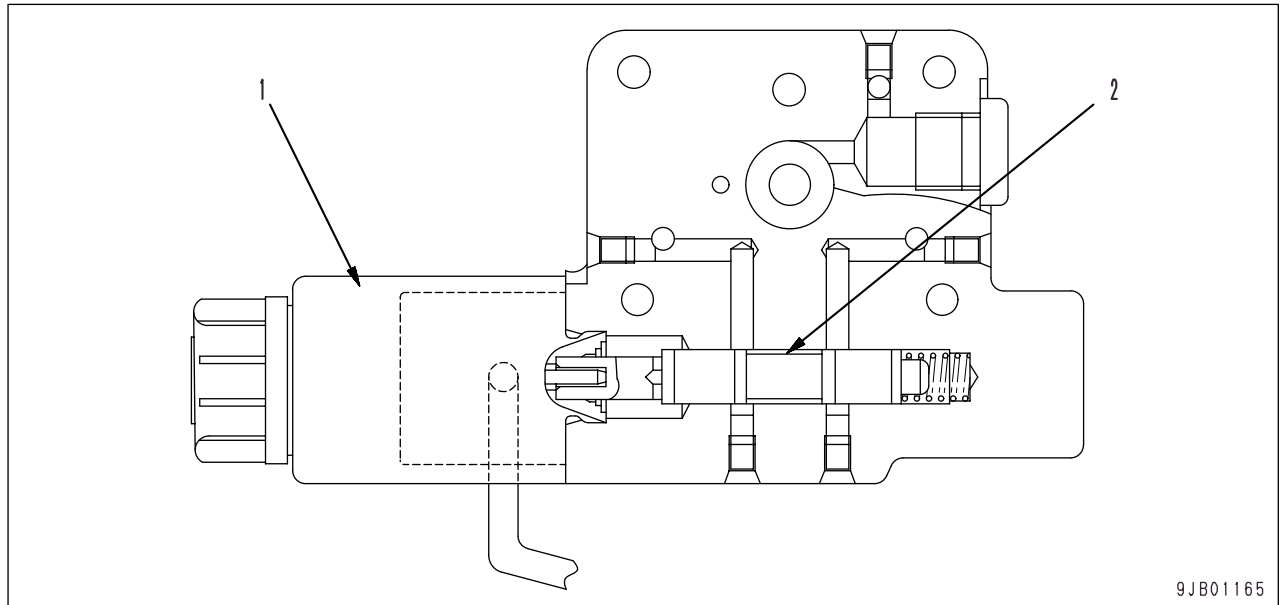

1. Forward-reverse shifting solenoid valve
2. Forward-reverse shuttle valve

Function

- The forward-reverse shuttle valve is installed to the rear part of HST motor 2 and used to grasp and change the position of the forward-reverse shifting solenoid valve to control where to lead the hydraulic pressure for the HA servo valve. Accordingly, shocks made when the oil pressure changes for gear shifting are reduced.

Operation

- The electric signals given to the forward-reverse shifting solenoid valve of the HST pump are used for forward-reverse shifting solenoid valve (1) and linked to the forward-reverse shifting mechanism.
- Forward-reverse shuttle valve (2) changes the hydraulic pressure applied to the HA servo valve according to the forward-reverse shifting command.

Low-speed mode

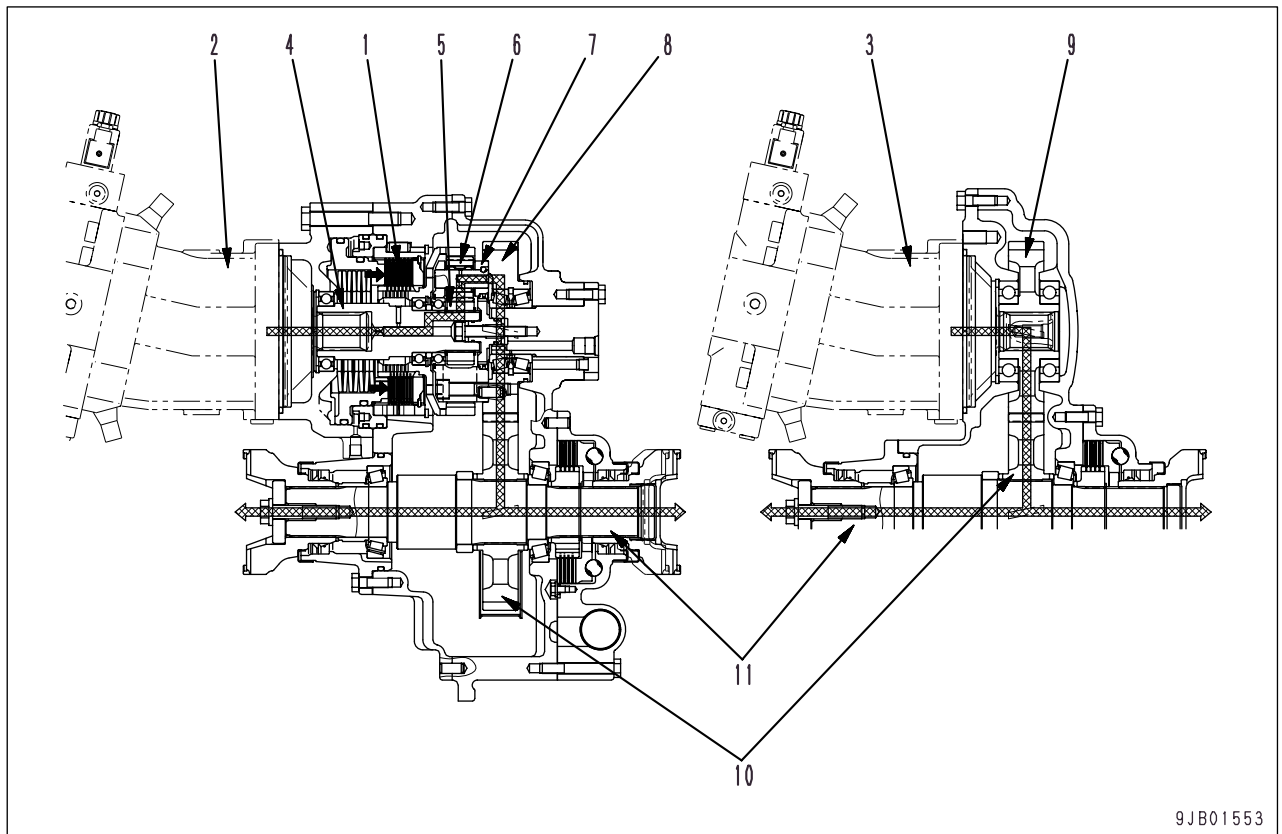

9JB01553

Operation

- In the low-speed mode, transfer clutch (1) is fixed and the power of both HST motor 1 (2) and HST motor 2 (3) is transmitted to output shaft (11).
- The power of HST motor 1 (2) is transmitted through input shaft (4), sun gear (5), planetary gear (6), carrier (7), motor 1 gear (8), and output gear (10) to output shaft (11).
- The power of HST motor 2 (3) is transmitted through motor 2 gear (9) and output gear (10) to output shaft (11).

Torque proportioning differential

Outline

- A 4-wheel-drive wheel loader, as a construction machine, must naturally work on places where the ground condition is bad. If its tires slip in such places, its function lowers and the lives of the tires are shortened. To solve this problem, the torque proportioning differential is used.
- Differential pinion gear (4) of this differential has an odd number of teeth. The meshing points of pinion gear (4) and side gears (3) change according to the difference of the road resistance. Consequently, the traction forces of the tires on both sides change.

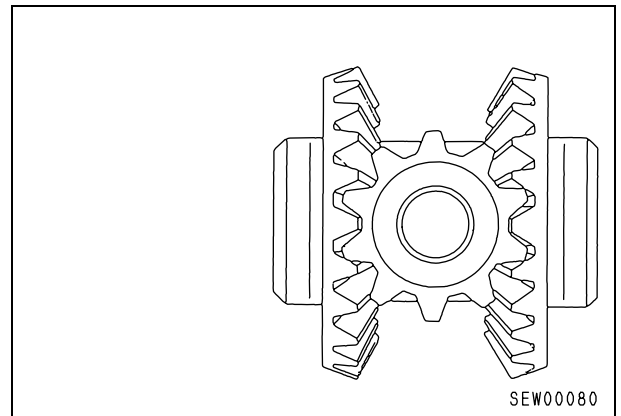
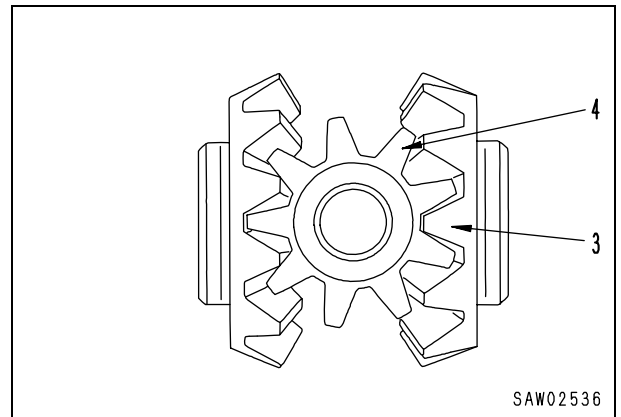

1. Front axle
2. Tension bolt
3. Front frame
4. Center hinge pin
5. Rear axle
6. Rear frame
7. Additional counterweight (If equipped)
8. Counterweight

Outline

- Since front axle (1) receives forces directly during work, it is fixed to front frame (3) directly with tension bolts (2).
- Rear axle (5) rocks at the center of rear frame (6) so that each tire will keep in contact with ground even when the machine travels on soft ground.
- Front frame (3) and rear frame (6) are connected by center hinge pin (4) with the bearing between them. The steering cylinders on both sides connect front frame (3) and rear frame (6) and move to adjust the bending angle, or the turning radius.

Outline

- The orbit-roll valve is connected directly to the shaft of the steering wheel. It switches the flow of oil from the steering pump to the left and right steering cylinders to determine the direction of travel of the machine.
- The orbit-roll valve, broadly speaking, consists of the following components: rotary type spool (3) and sleeve (5), which have the function of selecting the direction, and the Girotor set (a combination of rotor (8) and stator (9)), which acts as a hydraulic motor during normal steering operations, and as a hand pump (in fact, the operating force of the steering wheel is too high, so it cannot be operated) when the steering pump or engine have failed and the supply of oil has stopped.

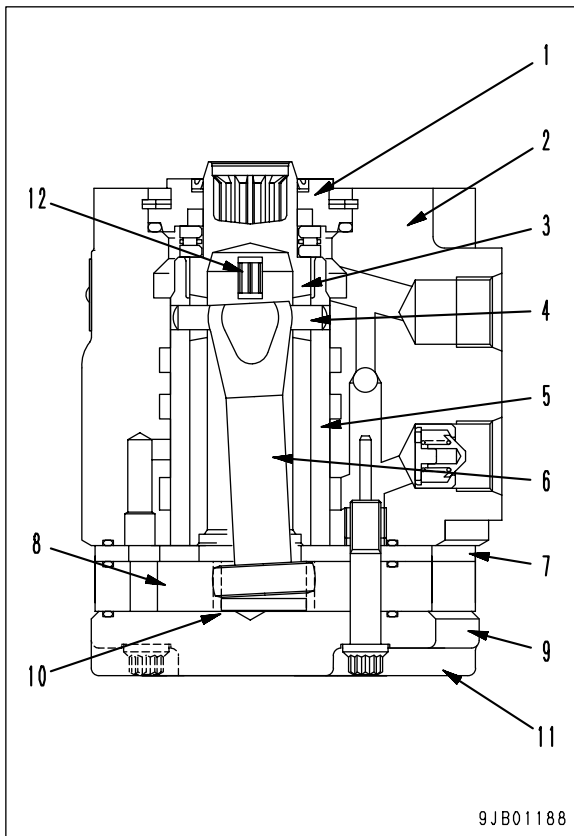

Structure

- Top (A) of spool (3) is connected to the drive shaft of the steering column and further connected to sleeve (5) through center pin (4) (which is not in contact with the spool while the steering wheel is in neutral) and centering spring (12).
- Top (B) of drive shaft (6) is engaged with center pin (4) and combined with sleeve (5) in one body, and the bottom is engaged with the spline of rotor (8) of the gerotor set.
- Valve body (2) has 5 ports, which are connected to the pump circuit, tank circuit, left steering circuit, right steering circuit, and LS circuit respectively. The ports on the pump side and tank side are connected by the check valve in the body. If the pump or engine fails, the oil can be sucked through this check valve directly from the tank side.

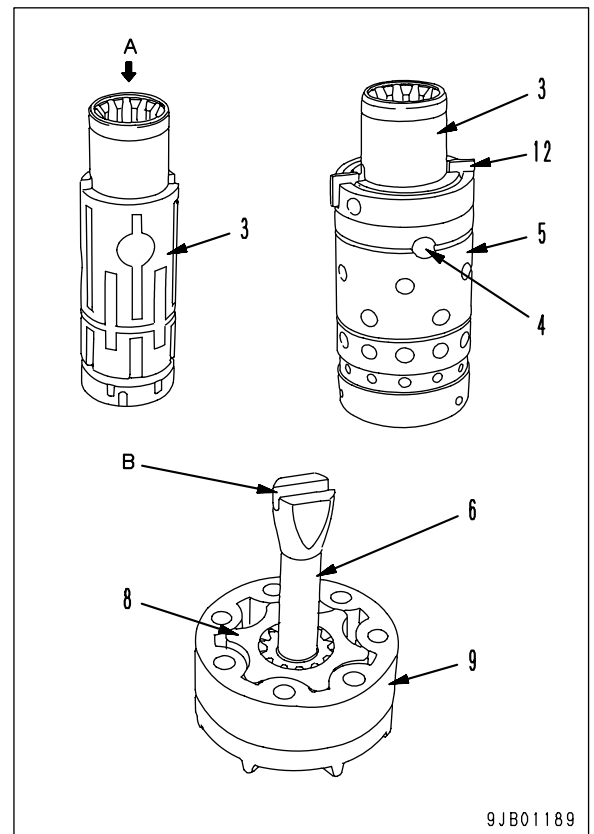

EMERGENCY STEERING PIPING

(If equipped)

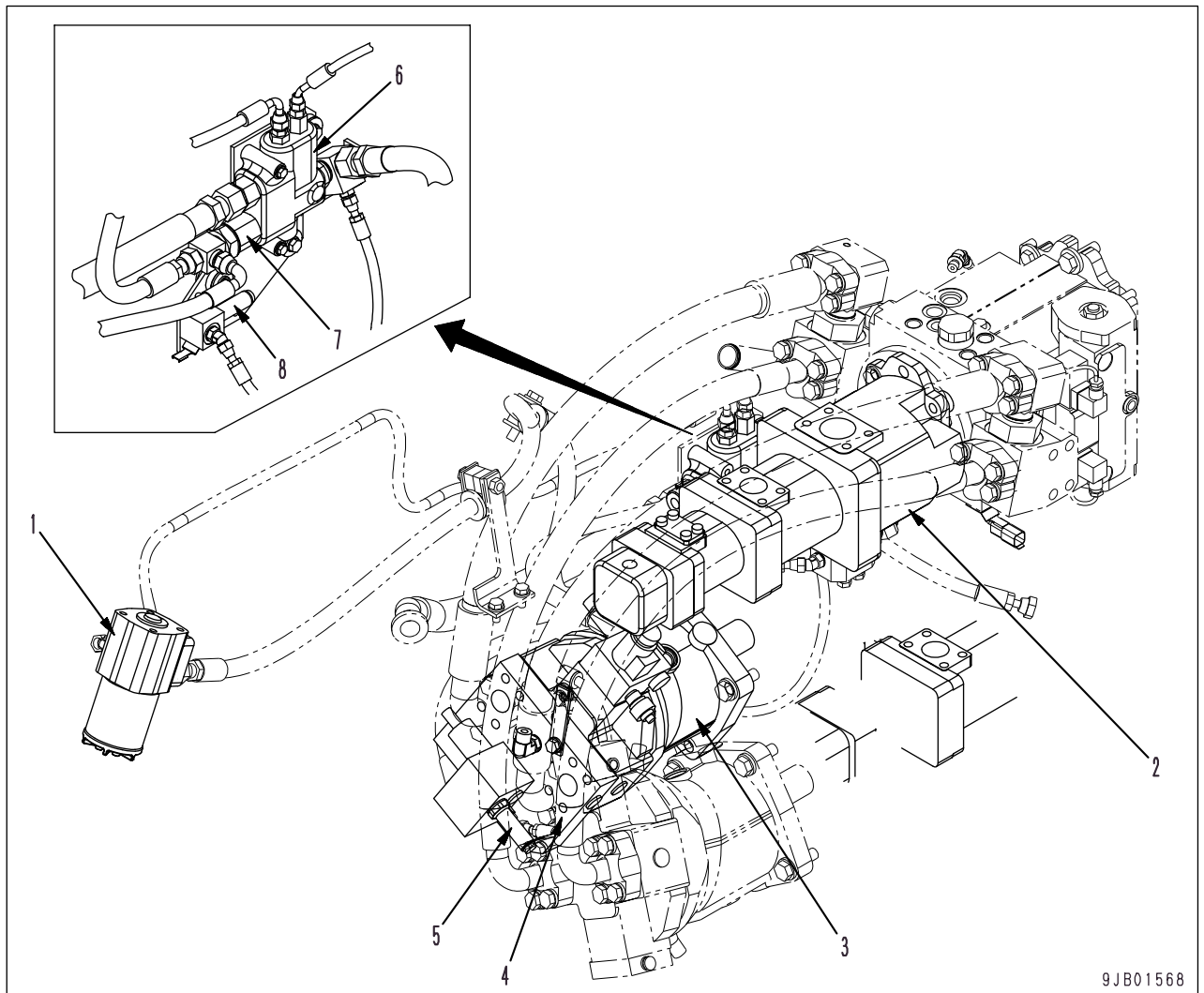

9JB01568

1. Orbit-roll valve
2. Steering pump
3. HST motor 2
4. Emergency steering valve
5. Pressure switch (For detecting operation of emergency steering)
6. Priority valve
7. Check valve
8. Pressure switch (for detecting drop of steering oil pressure)

Outline

- The brake has a wet-type multiple-disc structure, and consists of piston (3), inner ring (5), disc (9), outer ring (8), and spring (4).
- The brake cylinder consists of differential housing (1) and bearing carrier (2), and piston (3) is assembled in it.
Inner ring (5) and outer ring (8) are joined to the spline portion of axle housing (7).
- Disc (9) has a lining stuck to both sides. It is assembled between inner ring (5) and outer ring (8), and is joined by the spline of sun gear shaft (6).

Outline**When brake is applied**

- When the brake pedal is depressed, pressure oil **P** goes from the hydraulic tank through the pump and brake charge valve. It acts on the piston inside the brake cylinder and the piston (2) slides.
Therefore, piston (2) stops the rotation of discs (4) fitted between inner ring (3) and outer ring (5), and applies the brake to the machine.

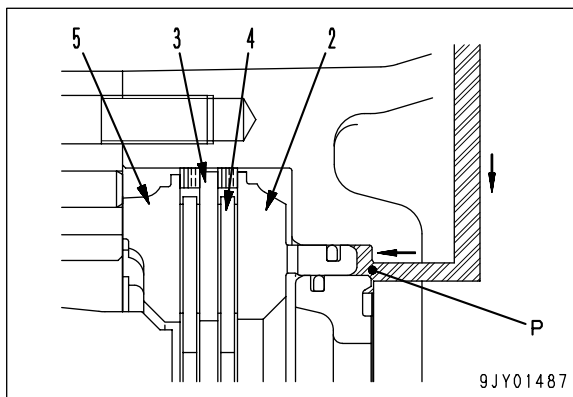
**When brake is released**

- When the oil pressure is released, piston (2) is returned to its original position by the force of spring (8), a gap is formed between inner ring (3) and outer ring (5), and discs (4) become free. Lattice shape grooves are cut into the lining stuck to disc (4), and when disc (4) is rotating, oil flows in the grooves and carries out cooling of the lining.

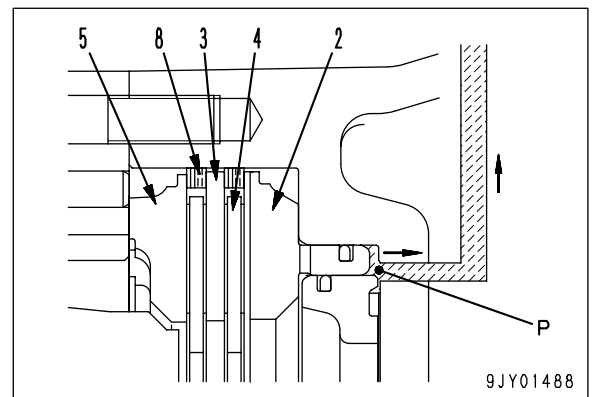

Unit: mm

No.	Check item	Criteria				Remedy
5	Side clearance	Model	Standard clearance	Clearance limit		Replace
		SAR(3)90	0.10 – 0.15	0.19		
		SAR(2)32				
		SBR(1)18				
SBR(1)12						
6	Clearance between inside diameter of plain bearing and outside diameter of gear shaft	SAR(3)90	0.083 – 0.144	0.20		
		SAR(2)32	0.071 – 0.121			
		SBR(1)18	0.068 – 0.115			
		SBR(1)12				
7	Diving depth of pin	Model	Standard size	Tolerance	Repair limit	
		SAR(3)90	13	0 -0.5	-	
		SAR(2)32	12			
		SBR(1)18	10			
		SBR(1)12	7	+0.5 0		
8	Spline rotating torque	13.8 – 28.5 Nm {1.4 – 2.9 kgm}				
-	Discharge amount Oil: SAE10W Oil temperature: 45 - 55°C	Model	Speed (rpm)	Discharge pressure (MPa {kg/cm ² })	Standard discharge amount (ℓ/min)	Discharge amount limit (ℓ/min.)
		SAR(3)90	2,500	20.6 {210}	129	119
		SAR(2)32			91	82
		SBR(1)18			23	21
		SBR(1)12			2.9 {30}	27

WORK EQUIPMENT CONTROL VALVE

1. 2-Spool valve

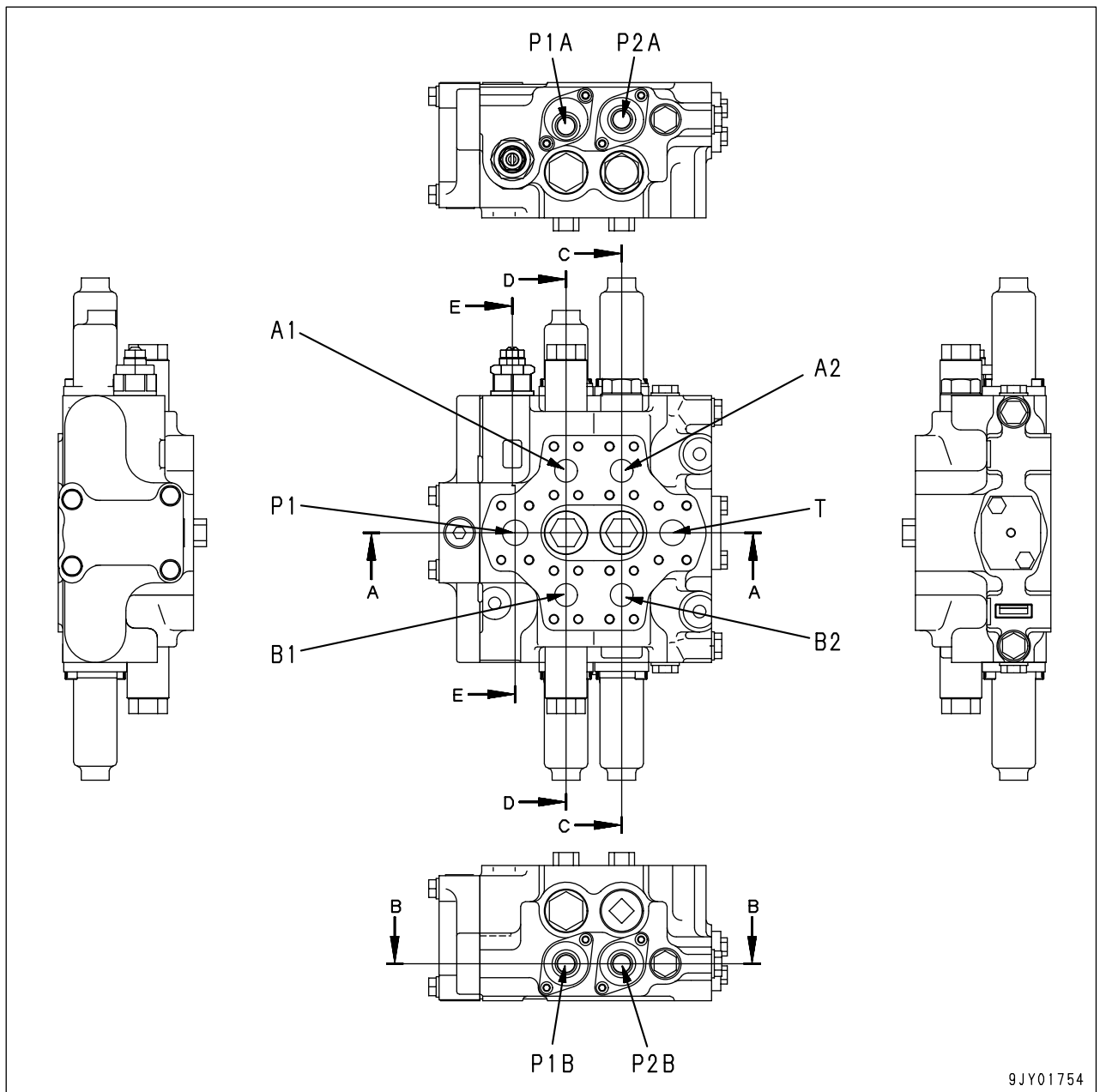

9JY01754

P1: From steering pump
 T: Drain port (To tank)
 A1: To bucket cylinder head
 A2: To lift arm cylinder head
 B1: To bucket cylinder bottom
 B2: To lift arm cylinder bottom

P1A: From PPC valve P1 port
 P1B: From PPC valve P2 port
 P2A: From PPC valve P3 port
 P2B: From PPC valve P4 port

(6) Bucket spool tilt position

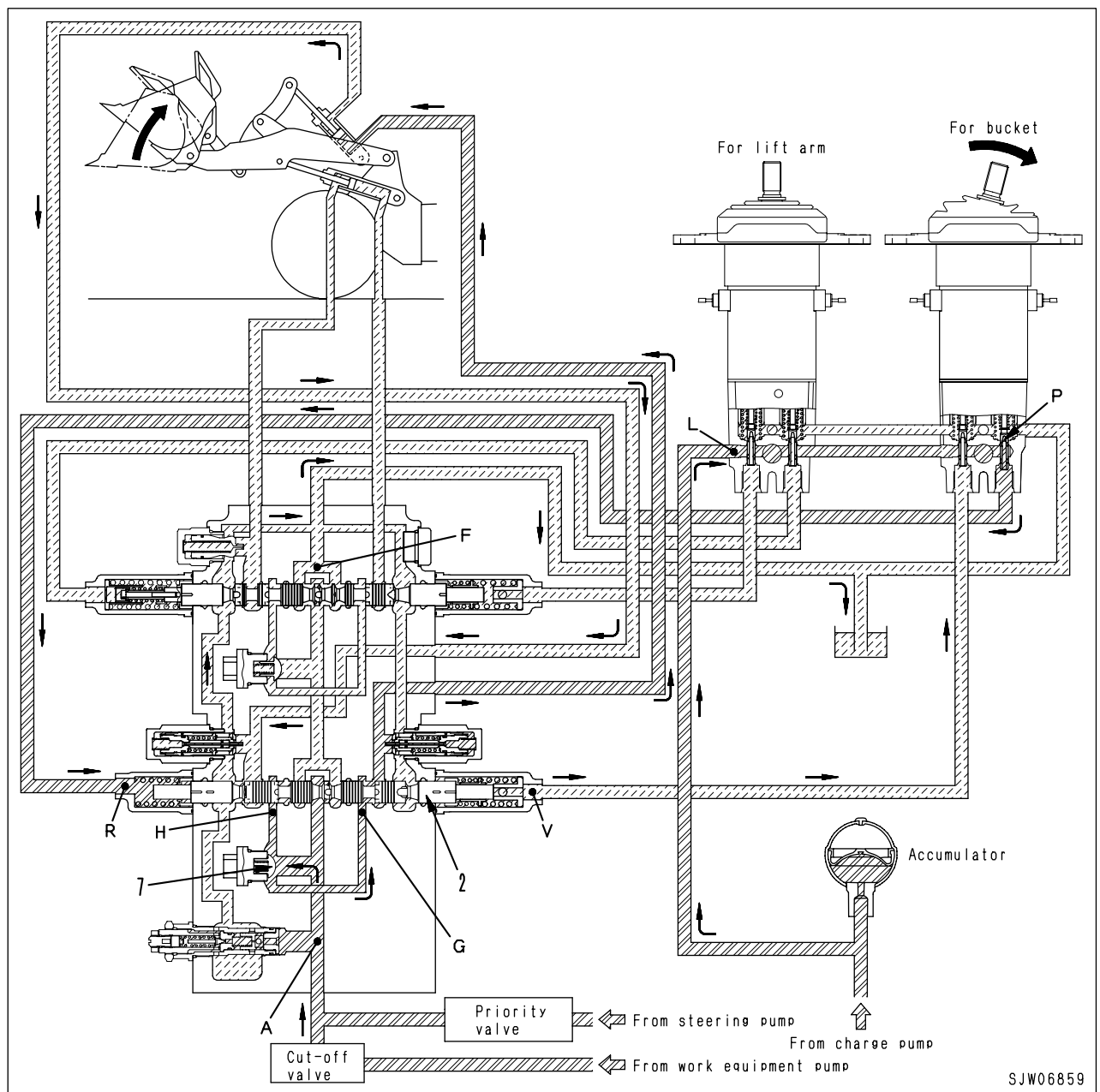
**Operation**

- If the bucket control lever is pulled, the oil in port L of the PPC valve flows through port P to port R of the work equipment control valve.
- The oil in port V flows to the drain circuit. The oil in port R sets bucket spool (2) in the tilt position.
- Since the oil from the pump is stopped by spool (2), the oil from port A pushes check valve (7) open.
- The oil from check valve (7) flows through port G to the bucket cylinder bottom.
- The oil in the bucket cylinder head flows through port H into drain port F and then returns to the tank. Accordingly, the bucket is tilted.

2. When in fine control NEUTRAL → Fine control)

- If rod (7) and piston (13) are pushed by disc (8), retainer (12) is pushed and spool (1) is also pushed down through metering spring (2).
- Accordingly, fine control hole **f** is disconnected from pump pressure chamber **PP** and connected to pump pressure chamber **PP** almost simultaneously, and then the pilot oil of the main pump flows from port **P1** to port **PB**.
- If the pressure in port **P1** rises, spool (1) is pushed back and fine control hole **f** is disconnected from pump pressure chamber **PP** and connected to drain chamber **D** almost simultaneously to release the pressure in port **P1**.
- As a result, spool (1) moves up and down to balance the force of metering spring (2) with the pressure in port **P1**.

The positional relationship between spool (1) and body (14) (where fine control hole **f** is between drain chamber **D** and pump pressure chamber **PP**) does not change until retainer (12) comes in contact with spool (1).

- Since metering spring (2) is compressed in proportion to the stroke of the control lever, the pressure in port **P1** rises in proportion to the stroke of the control lever.
- Accordingly, the control valve spool moves to a position at which the pressure in the chamber **PB** (equal to the pressure in port **P1**) is balanced with the force of the control valve spool return spring.

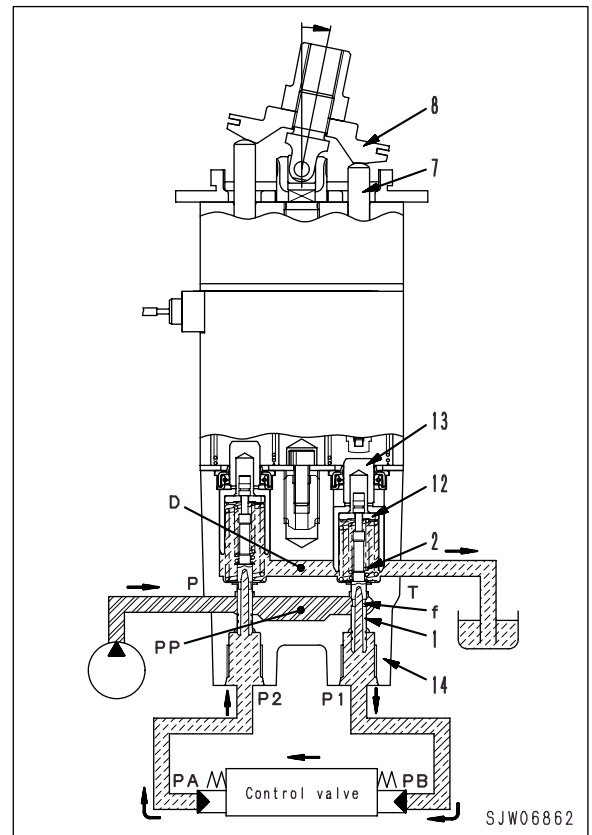

- This machine monitoring system is equipped with the service mode function to facilitate the troubleshooting work for respective controllers (including the machine monitor itself) on the network. The description below applies to the contents of the main functions.
1. Electric fault history
This function will indicate the electric fault history data of respective controllers being memorized by the machine monitor. Also, it can be used to delete the aforementioned data.
 2. Machine fault history
This function will indicate the machine fault history and machine fault history data of respective controllers being memorized by the machine monitor.
 3. Real time monitor
This function will make real time indications of the inputting data and outputting data being recognized by respective controllers on the network.
 4. Maintenance monitor
This function is to be used for revisions of the preset filter and oil changing time. (Revision of the time for the maintenance monitor operation)
 5. Selection of optional items
This function is used to set the machine model, tier size, and optional equipment.
 6. Controller initializing function
This function is being used to effect the settings of this machine monitor before shipment from our factory.
- The machine monitoring system consists of the machine monitor proper, buzzer, and switches that are used for inputting data to the machine monitor proper, sensors, respective controller on the network, and relevant switches and sensors.

LIST OF ITEMS DISPLAYED ON MONITOR

Condition for judging running of engine: When running judgment A or B is satisfied, it is judged that the engine is running.

1. Input is given to alternator terminal R (24 V).
2. Engine oil pressure is normal (Open).
3. Signal of terminal C has been input at least once after IGN_BR, and then it has been turned OFF at least once.

Judgment of operation

- A: After 1 and 2 are established simultaneously, it is judged that the engine is running until IGN_BR is turned OFF.
- B: If 1 and 3 are established simultaneously or 2 and 3 are established simultaneously, it is judged that the engine is running. If both signals of 1 and 2 are lost, however, it is judged that the engine is stopped even if IGN_BR is turned ON.

Lamp	Period of lamp	Buzzer	Condition for operation	Period of buzzer	Priority
○: ON	—	◎: ON and OFF continuously	Warning for dangerous condition (When error indication or caution is turned on)	Period: 1,600 msec ON: 800 msec OFF: 800 msec (DUTY 50%)	1
◎: Flash	Period: 1,600 msec ON: 800 msec OFF: 800 msec (DUTY 50%)	☆: Intermittent	Caution for wrong operation, etc. (When abnormal operation is performed)	Period: 240 msec ON 1: 80 msec OFF: 160 msec	2
☆: Intermittent	Period: 240 msec ON 1: 80 msec OFF: 160 msec	△: Cancellation sound	Cancellation of calibration, etc. (When operation is not accepted)	ON: 1,000 msec (Once)	3
△: Condition is set separately	—	▲: Completion sound	Completion of calibration, etc. (When completed normally)	ON: 1,000 msec. OFF: 160 msec. ON: 1,000 msec (Once)	4

- 4) Clearing individually the fault history of electric system, and clearing the entire fault history of electric system (the third layer)

Select YES or NO with the < or > SW.

Cursor () blinks on the selected item. Pressing the ■SW changes the display as follows, with the history reset if YES was selected, or not if NO was selected:

- a. If No (cancel) was selected, the display returns to the [Display the fault history of electric system] screen of the relevant fault (i.e., the screen before entering the [Clearing individually (entirely) the fault history of electric system] screen).
- b. If YES (clear) was selected, the display returns to the [Display the fault history of electric system] screen of a fault next to the relevant fault. If the fault history to be shown exhausts, the screen returns to the [Select displaying the fault history of electric system] screen.

By default, the cursor is on NO (no reset) to prevent resetting by error.

A current fault cannot be cleared. If it was selected, a peep sounds for one second to notify that the operation is cancelled.

If a fault was cleared, peeps sound (on for 0.1 sec. - off for 0.1 sec. - on for 0.1 sec.) to notify that the operation has been accepted.

If the entire history was cleared, it is considered to have been cleared even if it consisted of only one fault .

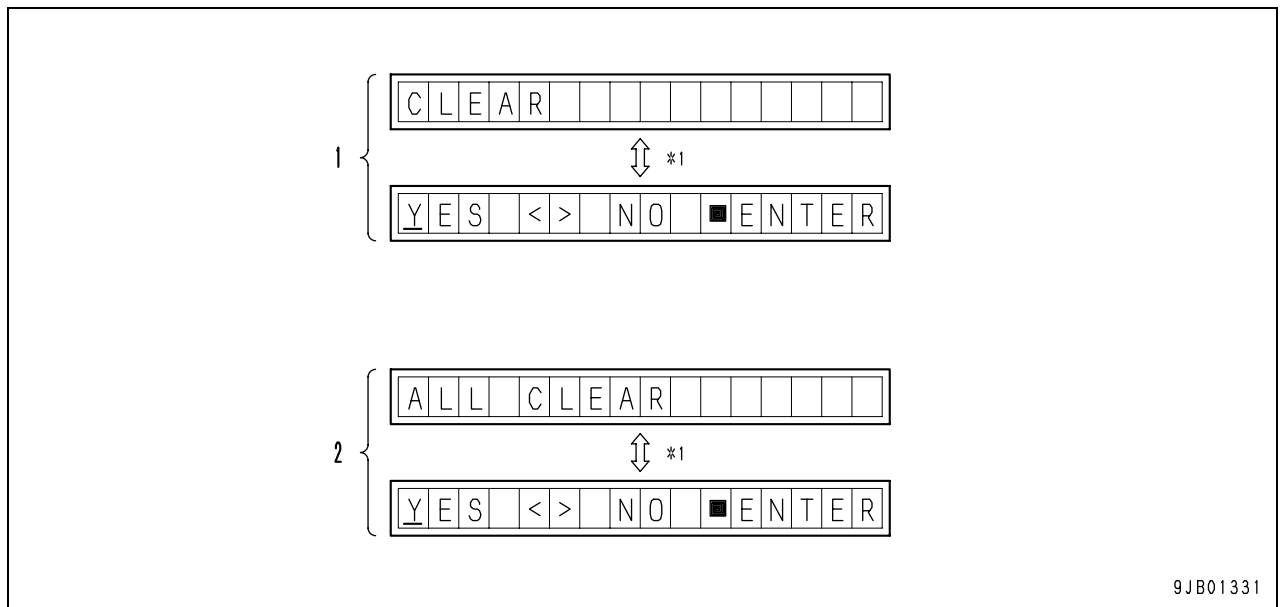

*1: Displayed alternately every 3 seconds

- 1.[Clear individually the electrical equipment system failure history] screen
- 2.[Clear entirely the electrical equipment system failure history] screen

- 5) Check of change of maintenance interval time (fourth layer)
 Select YES or NO with the < or > SW. The cursor () blinks on the selected item. Pressing the ■SW returns the screen to the [Select maintenance item] screen with the change done if YES was selected, or not if NO was selected.
 By default, the cursor is on NO (the change not done) to prevent resetting by error.
 When the change of the set time is finished, the operation acceptance peeps (on for 0.1 sec → off for 0.1 sec → on for 0.1 sec) are heard.

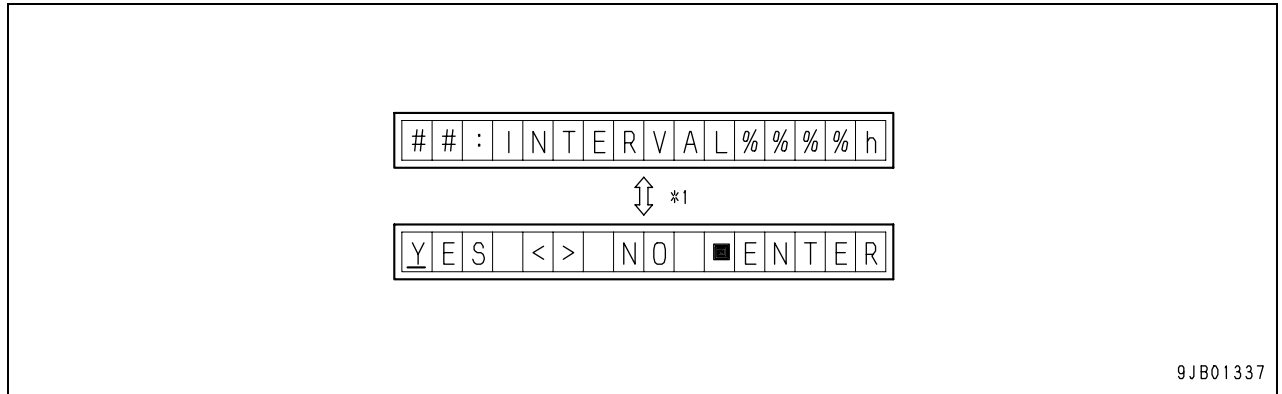

*1: Displayed alternately every 3 seconds

##: ID No. of each maintenance item
 % % % %: Interval time (4 digits) to be changed

The maintenance interval time is set as shown in the following table, when shipped.

Item	Replacement interval time (h)	Displayed item name	ID No.
Engine oil	500	ENG OIL	01
Engine oil filter	500	ENG FILT	02
Fuel filter	500	FUEL FILT	03
Transfer oil	1,000	TRANSF OIL	25
HST oil filter	1,000	HST FILT	26
Hydraulic oil filter	2,000	HYD FILT	04
Hydraulic oil	2,000	HYD OIL	10
Axle oil	2,000	AXLE OIL	15

HST CONTROLLER

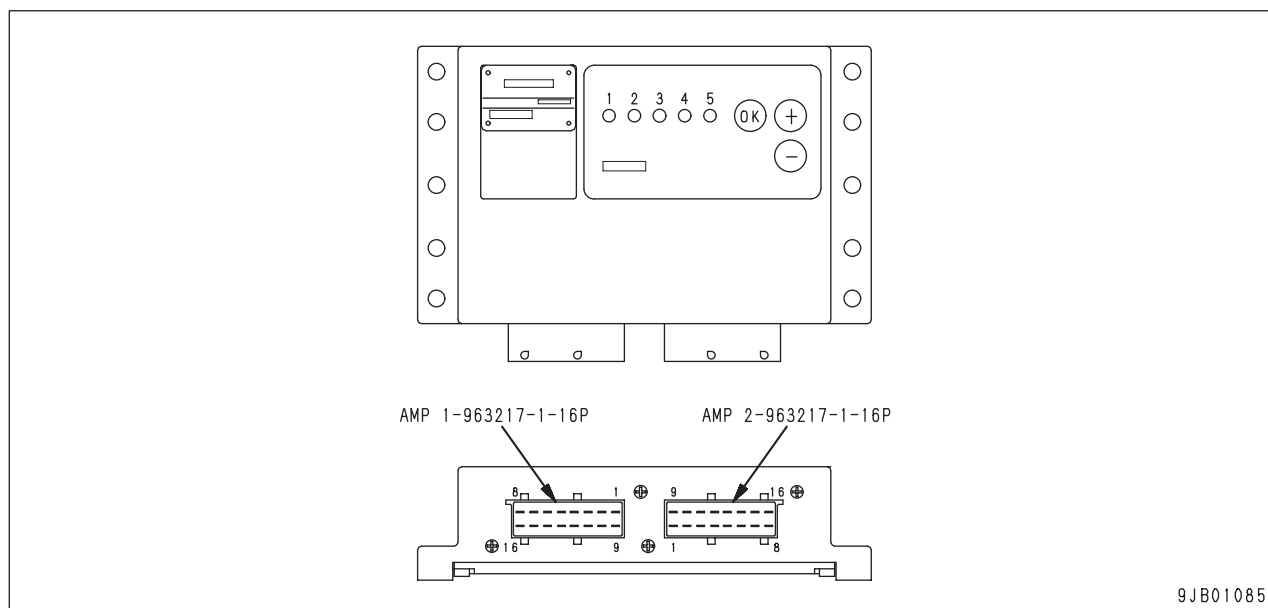

Input and output signals

AMP 1-963217-1-16P [CN-L41]

Pin No.	Signal name	Input/Output signal
1	Travel speed control potentiometer signal	Input
2	Travel speed control potentiometer GND	-
3	HST pressure sensor signal	Input
4	HST pressure sensor GND	-
5	HST motor 2 solenoid	Output
6	HST motor 1 solenoid	Output
7	Power supply (+24 V)	Input
8	Power supply (+24 V)	Input

Pin No.	Signal name	Input/Output signal
9	NC	-
10	Travel speed adjustment potentiometer (+5 V)	Output
11	NC	-
12	HST pressure sensor (+5 V)	Output
13	Travel speed signal A (Pulse)	Input
14	Clutch solenoid	Output
15	NC	-
16	GND	-

AMP 2-963217-1-16P [CN-L42]

Pin No.	Signal name	Input/Output signal
1	NC	-
2	Checker H	Input and output
3	Traction control signal	Input
4	Engine speed signal	Input
5	Travel speed signal B (Revolving direction)	Input
6	NC	-
7	Checker C	Input and output
8	CAN-L	Input and output

Pin No.	Signal name	Input/Output signal
9	NC	-
10	NC	-
11	Engine speed sensor GND	-
12	Gear speed signal	Input
13	NC	-
14	Checker D	Input and output
15	Checker B	Input and output
16	CAN-H	Input and output

ELECTRONICALLY CONTROLLED SUSPENSION SYSTEM

Electronically Controlled Suspension System (Abbreviation: ECSS) (If equipped)

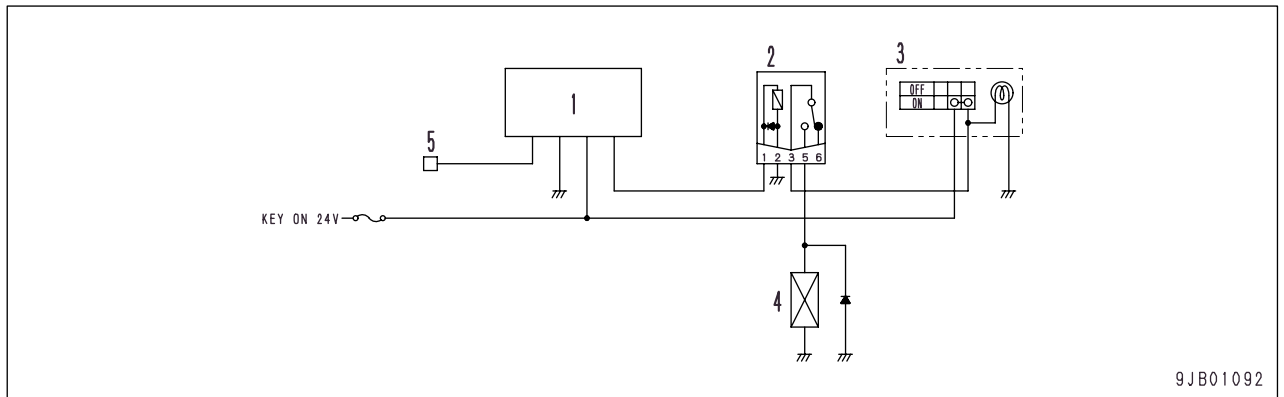

1. ECSS controller
2. ECSS relay
3. ECSS switch
4. ECSS solenoid
5. Speed sensor

Function

- The controller controls the ECSS solenoid valve automatically to turn the accumulator charged with high-pressure gas ON and OFF to damp the vertical movement of the work equipment and reduce the jolts of the machine during high-speed travel. Consequently, the operator comfort is improved, the material spills less, and the working efficiency is increased.

System operation table

ECSS switch		Travel speed (km/h)	ECSS solenoid output	State of ECSS
OFF		0 – MAX	OFF	OFF
ON	Turn system ON	0 – 6	OFF	OFF
		6 – MAX	ON	ON
	Turn system OFF	MAX – 5	ON	ON
		5 – 0	OFF	OFF

Note: The travel speed range shown above is for the tire size of 20.5-25.

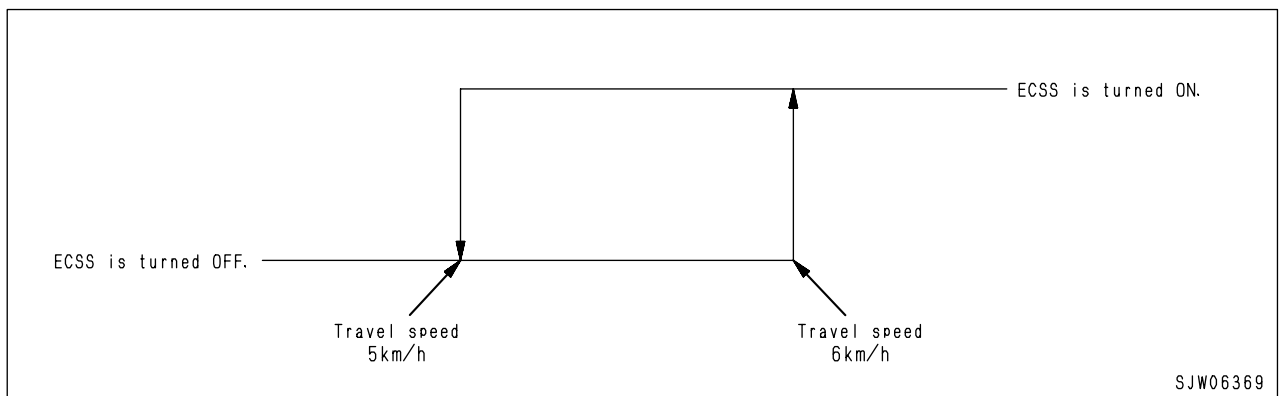

20 TESTING AND ADJUSTING

Standard value table for engine	20-2
Standard value table for chassis	20-3
Testing and adjusting	20-101
Troubleshooting	20-201

★ Note the following when making judgements using the standard value tables for testing, adjusting, or troubleshooting.

1. The standard value for a new machine given in the table is the value used when shipping the machine from the factory and is given for reference. It is used as a guideline for judging the progress of wear after the machine has been operated, and as a reference value when carrying out repairs.
2. The service limit value given in the tables is the estimated value for the shipped machine based on the results of various tests. It is used for reference together with the state of repair and the history of operation to judge if there is a failure.
3. These standard values are not the standards used in dealing with claims



When carrying out testing, adjusting, or troubleshooting, park the machine on level ground, insert the safety pins, and use blocks to prevent the machine from moving.



When carrying out work together with other workers, always use signals and do not let unauthorized people near the machine.



When checking the water level, always wait for the water to cool down. If the radiator cap is removed when the water is still hot, the water will spurt out and cause burns.



Be careful not to get caught in the fan, fan belt or other rotating parts.

MEASURING HYDRAULIC SPEED

- ★ Check that the low idling and high idling speeds are the standard value.
 - ★ Check that the engine speed is within the standard value. If it is not within the standard value, loosen the linkage and check that there is no play.
1. Start the engine and run at low idling.
 2. Operate the work equipment control lever and operate the cylinder to the end of its stroke.
 3. Relieve the cylinder at the end of its stroke and measure the engine speed at this point.

MEASURING FULL STALL SPEED

- Measure the engine speed when the HST stall and hydraulic stall (bucket dump end relief) are carried out at the same time.
- ★ Measure the full stall if the HST stall speed and hydraulic stall speed are normal. If either of them shows any abnormality, remove the problem and carry out the measurement again.

MEASURING EXHAUST GAS COLOR

Special tools required

Symbol		Part No.	Part Name
B	1	799-201-9001	Handy Smoke Checker
	2	Commercially available	Smoke meter

 When installing or removing the measuring equipment, be careful not to touch any hot parts.

- ★ When measuring in the field where there is no air or power supply, use Handy Smoke Checker **B1**; when recording official data, use Smoke meter **B2**.
1. Measuring with Handy Smoke Checker **B1**
 - 1) Fit filter paper in tool **B1**.
 - 2) Insert the exhaust gas intake port into the exhaust pipe.
 - 3) Start the engine and raise the engine coolant temperature to the operating range.
 - 4) Accelerate the engine suddenly run it at high idling, and at the same time operate the handle of Handy Smoke Checker **B1** to catch the exhaust gas on the filter paper.



- 5) Remove the filter paper and compare it with the scale provided to judge the condition.
- 6) After completing the measurement, remove the measuring equipment and return to the original condition.

ADJUSTING ENGINE SPEED SENSOR

- ★ If engine speed sensor (1) (CN-E12) or the fly-wheel have been removed and installed, adjust as follows.

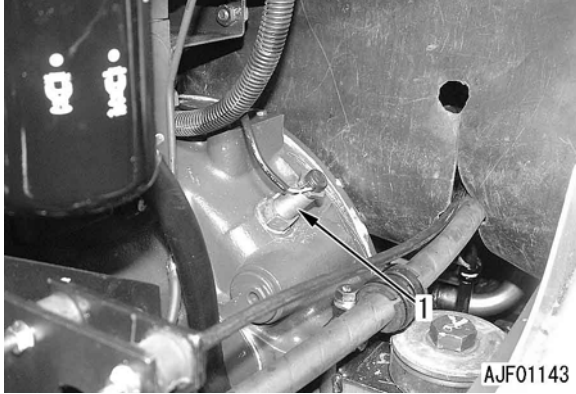

1. Open the engine right side cover.
2. Screw in until the tip of engine speed sensor (1) contacts the tip of the teeth of flywheel ring gear (2) lightly.
 - ★ Check that there are no metal particles or scratches on the tip of the sensor before installing.

 Thread: Gasket sealant (LG-5)

3. Turn engine speed sensor (1) back 1/2 - 1 turns from that point.
 - ★ Adjust clearance a between the tip of the sensor and the tip of the gear teeth to 0.75 - 1.5 mm.
4. Hold engine speed sensor (1) in position and tighten locknut (2).

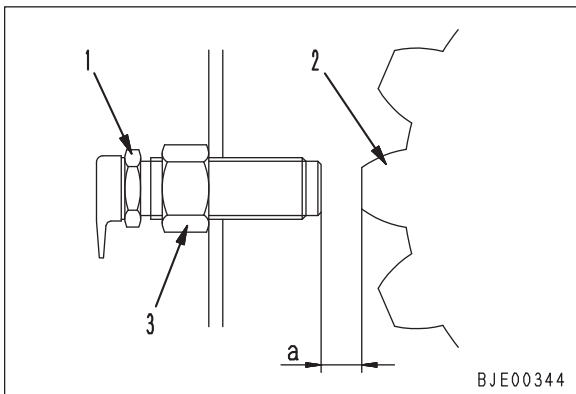

TESTING AND ADJUSTING AIR CONDITIONER COMPRESSOR BELT TENSION

Testing

Press a point midway between the fan pulley and the compressor pulley with a thumb and, and check belt deflection (a).

- Belt pressing force: 98.0 N {10 kg} or equivalent
- Deflection of belt: 10 - 15 mm

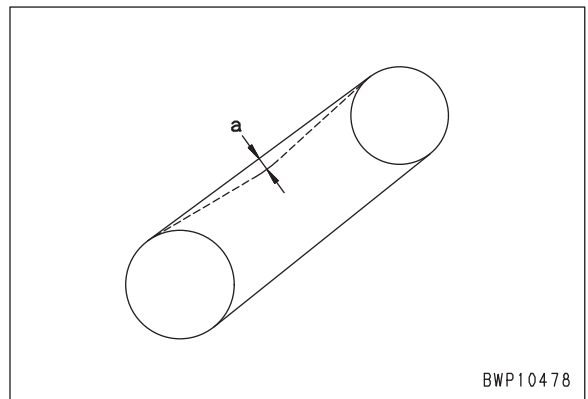

Adjusting

- ★ If the deflection is not correct, adjust as follows.

1. Loosen the mounting bolts (top and bottom: 2 each) of compressor bracket (1).
2. Loosen locknut (2), and use adjustment bolt (3) to move compressor bracket (1) and adjust the belt tension.
3. Tighten locknut (2).
4. Tighten the mounting bolts (top and bottom: 2 each) of compressor bracket (1).

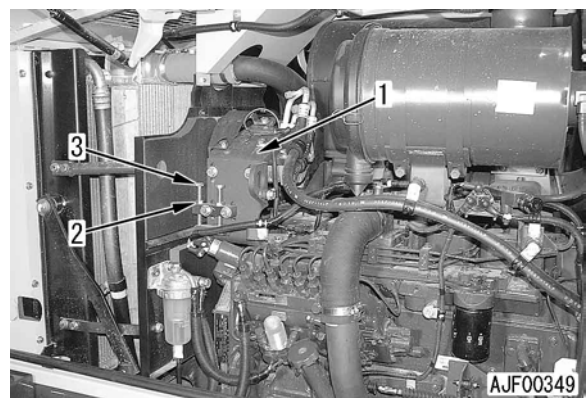

5. After adjusting the belt tension, check the belt tension again.

TESTING HYDRAULIC FAN

Special tools required

Symbol	Part No.	Part Name	
A	1	799-205-1100	Multi-tachometer KIT
C	1	799-101-5002	Analog type hydraulic tester
		790-261-1204	Digital type hydraulic tester
	6	799-401-3300	Adapter

! Set the bottom face of the bucket horizontal, lower the bucket completely to the ground, and put blocks under the tires.

! When removing the measurement plug and disconnecting the hose, loosen the oil filler cap slowly to release the pressure inside the hydraulic tank.

- ★ Measurement conditions
 - Hydraulic oil temperature: 45 - 55°C

Measuring fan speed

1. Open the radiator grill.
2. Set probe [2] to stand [1] of tachometer kit **A1** and install reflection tape [3] to the fan.

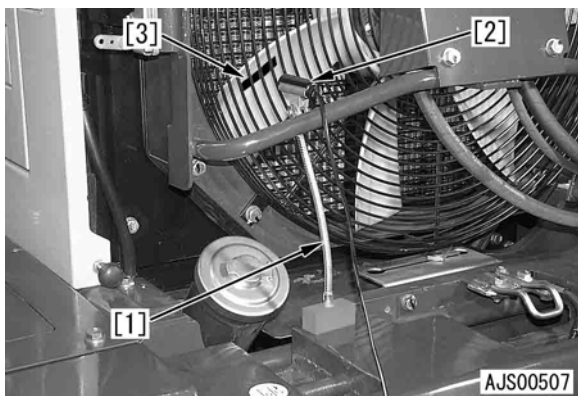

Multi-tachometer **A1**

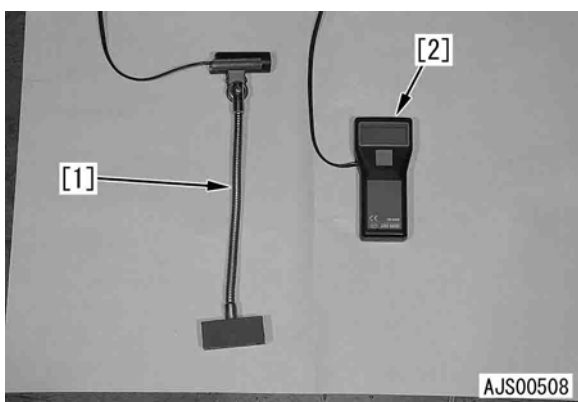

3. Start the engine, run at high idling, and measure the fan speed.

Measuring oil pressure

1. Open the radiator grill.
2. Disconnect hose (1), then connect tool **C1** (39.2 MPa {400 kg/cm²}) and **C6** (hose size: for # 05).

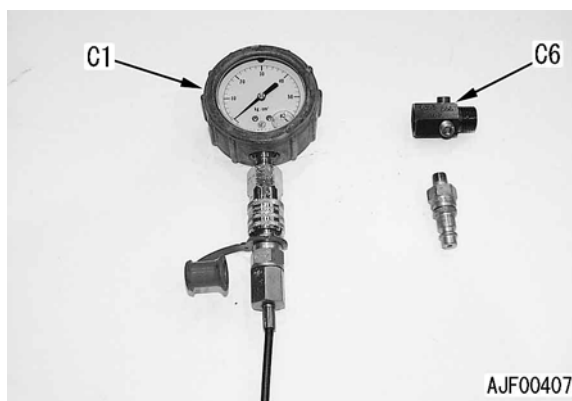
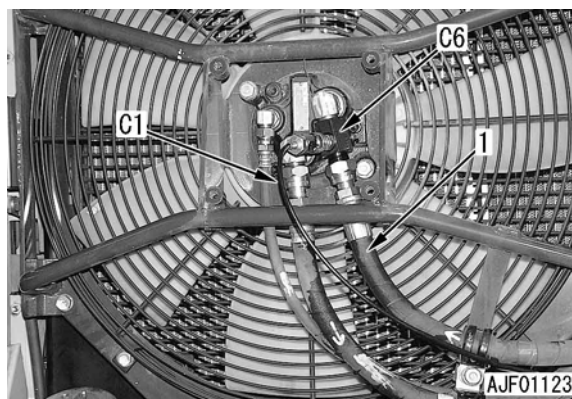

3. Start the engine and measure the fan drive oil pressure.

TESTING AND ADJUSTING PARKING BRAKE LINKAGE

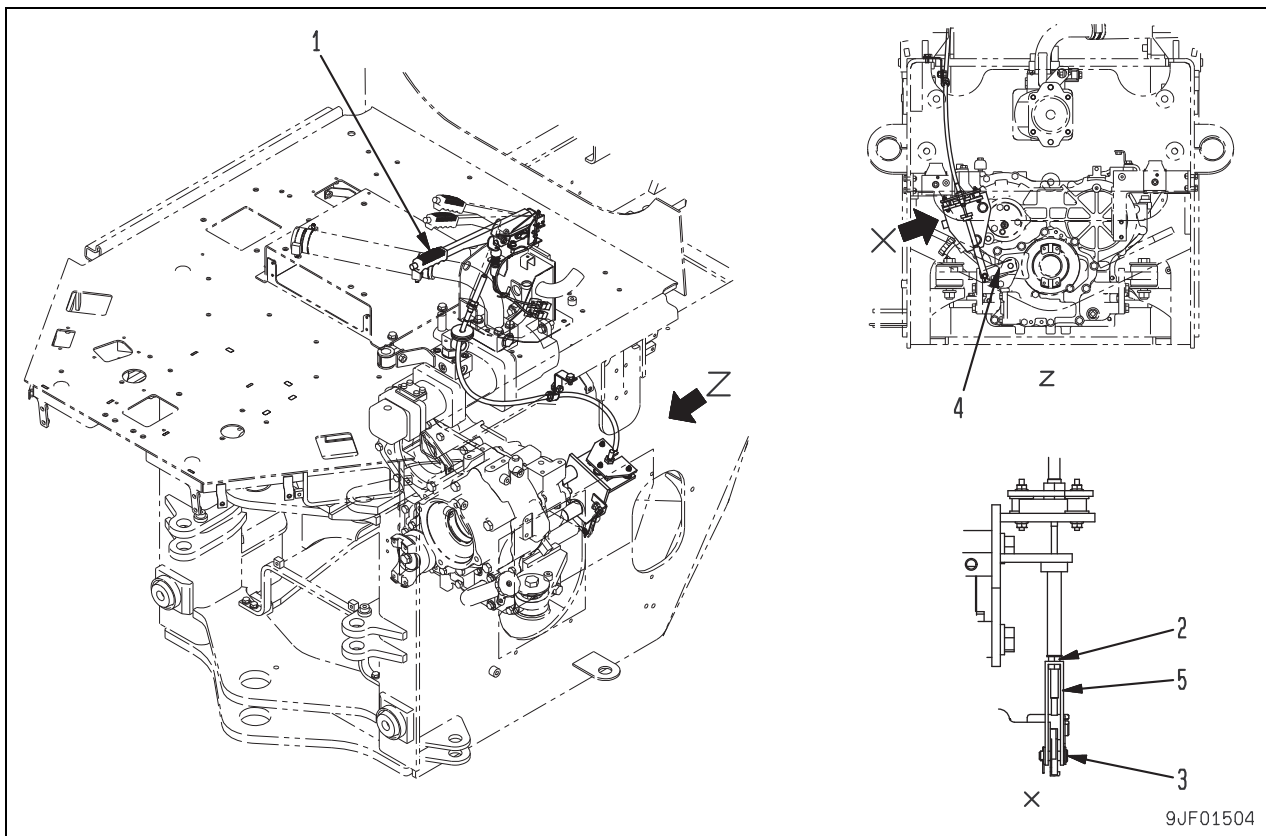

Special tools required

Symbol	Part No.	Part Name
H	79A-264-0091	Push-pull scale



Apply the parking brake and lock the tires with chocks.

Testing

- Release the parking brake.
 - ★ Check that the pawl of parking brake lever (1) is in the lowest position.
- Set tool H to position (B) at a distance of "a" from end (A) of the parking brake lever (excluding the button).
 - ★ Distance "a": **55 mm**
- Pull the parking brake lever with force of 294 - 392 N {30 - 40 kg}. If it is pulled by 8 teeth or more at this time, check the mounting parts of the parking brake linkage (on both lever side and brake side) for looseness. If the mounting parts are loosened, tighten them and perform the following adjustment.

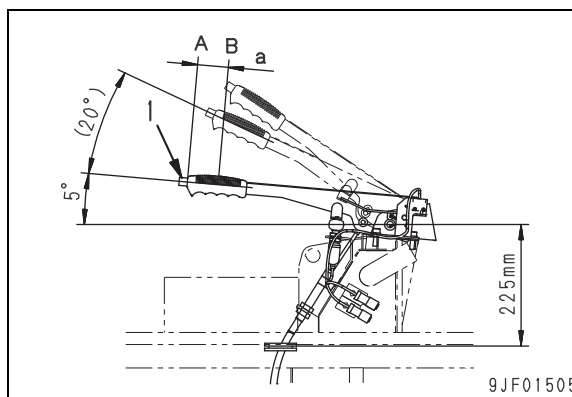

Adjusting

- Release the parking brake.
 - ★ Check that the pawl of parking brake lever (1) is in the lowest position.
- Loosen locknut (2) and remove clevis pin (3).
- Pull parking brake lever (4) in the releasing direction (Move it up by its play, however).

PROCEDURE FOR CHECKING DIODE

- ★ Use the following procedure to check the centralized diode (8-pin) and the individual diode (2-pin).
- ★ The direction of continuity of the individual diode is marked on the surface of the diode as shown in the diagram below.

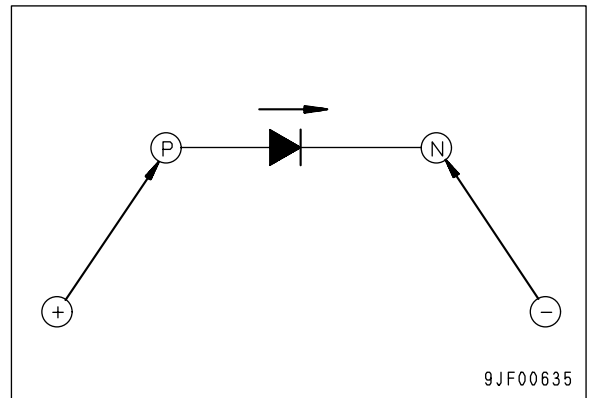
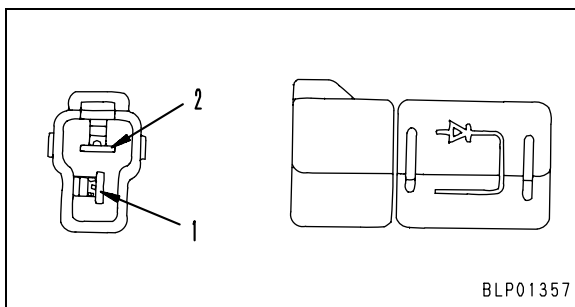
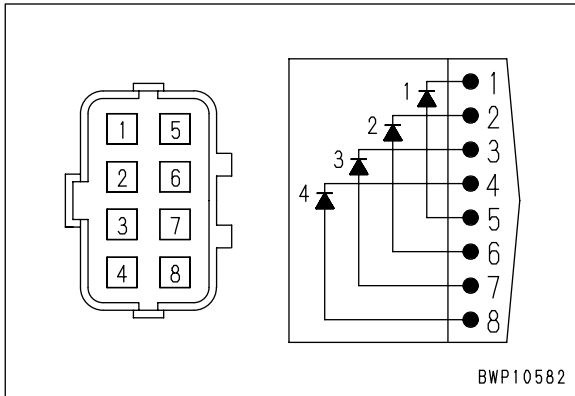

1. When using digital tester
 - 1) Switch to the diode range and check the display value.
 - ★ With a normal tester, the internal battery voltage is displayed.
 - 2) Put the red (+) end of the test pin in contact with the anode (P) of the diode, and the black (-) end in contact with the cathode (N), and check the display.
 - 3) Judge the condition of the diode from the display value.
 - Display value does not change: No continuity (defective)
 - Display value of changes: There is continuity (normal) (see ★)
 - ★ In the case of silicon diodes, a value between 460 and 600 is displayed.
2. When using analog tester
 - 1) Set to the resistance range.
 - 2) When doing the following, check the deflection of the indicator.
 - i) Put the red (+) end of the test pin in contact with the anode (P) of the diode, and the black (-) end in contact with the cathode (N).
 - ii) Put the red (+) end in contact with the cathode (N) and the black (-) end of the test pin in contact with the anode (P) of the diode.
 - 3) Judge the condition of the diode from the deflection of the indicator.
 - If the indicator does not deflect in Step i), but it deflects in Step ii): Normal (note that the amount of the deflection (resistance value) differs according to the type of tester and the selection of the measurement range.)
 - If the indicator deflects in both Step i) and Step ii): Defective (internal short circuit)
 - If the indicator does not deflect in either Step i) or Step ii): Defective (internal disconnection)

SPECIAL FUNCTIONS OF MACHINE MONITOR

Normal functions and special functions of machine monitor

The machine monitor is equipped with normal functions and special functions.

Various items of data are displayed on the character display in the middle of the machine monitor. Depending on the internal setting of the machine monitor, the display items are divided into automatic display items and items displayed when the machine monitor switches are operated.

1. Normal functions: Operator mode
 Functions for which the content is normally displayed or which can be used displayed and operated by the operator operating the switches.
2. Special functions: Service Mode
 Functions which the serviceman can display and operate with the special switches to carry out inspection, maintenance, and troubleshooting.

Operator mode		→	Service mode	
1	Service meter, time display	←	8	Electrical system trouble data display function
2	Odometer display function		9	Mechanical system trouble data display function
3	Filter, oil replacement interval display function		10	Machine data monitoring function
4	Language selection function		11	Filter, oil replacement time setting function
5	HST selection function		12	Option selection function
6	Action code display function		13	Initialize function
7	Failure code display function			

Separate table: Detailed phenomena of problem code (L)

Problem code	Nature
L0	Fill signal ON 2 or more channels for clutches not forming a set are input at same time
L1	Fill signal is ON when command current to ECMV is OFF
L2	Fuel pressure is greater than maximum specified value
L3	Corresponding component cannot be controlled
L4	ON/OFF signals for 2 systems do not match
L5	Potentiometer signal and switch signal do not match
L6	Engine speed signal, terminal C signal, signals for oil pressure switch, water temperature, etc. do not match operating condition or stopped condition of machine
L8	Analog signals for 2 systems do not match
LC	Speed signals for 2 systems do not match
LD	Switch has been kept pressed for abnormally long time
LH	Fill signal is OFF when command current to ECMV is ON

3) Handling control box

- (1) The control box contains a microcomputer and electronic control circuits.
This controls all of the electronic circuits on the machine, so be extremely careful when handling the control box.
- (2) Do not open the cover of the control box unless necessary.

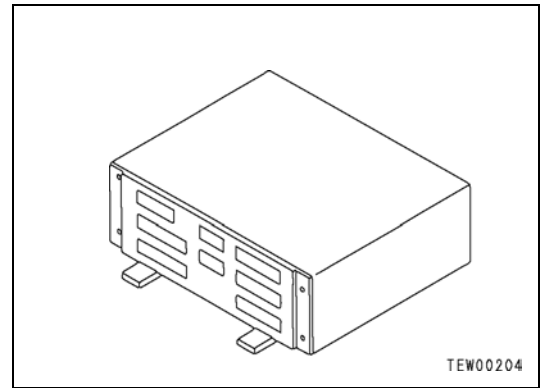

- (3) Do not place objects on top of the control box.
- (4) Cover the control connectors with tape or a vinyl bag.
Never touch the connector contacts with your hand.
- (5) Do not leave the control box in a place where it is exposed to rain.

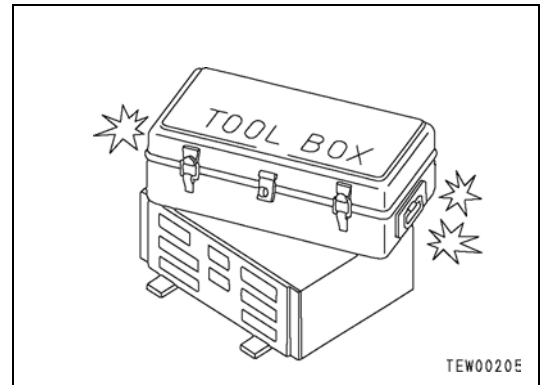

- (6) Do not place the control box on oil, water, or soil, or in any hot place, even for a short time. (Place it on a suitable dry stand)
- (7) Precautions when carrying out arc welding
When carrying out arc welding on the body, disconnect all wiring harness connectors connected to the control box. Fit an arc welding ground close to the welding point.

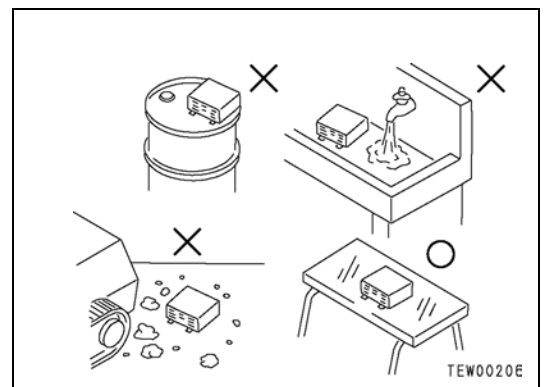

2. Points to remember when troubleshooting electric circuits

- 1) Always turn the power OFF before disconnecting or connecting connectors.
- 2) Before carrying out troubleshooting, check that all the related connectors are properly inserted.
★ Disconnect and connect the related connectors several times to check.
- 3) Always connect any disconnected connectors before going on to the next step.
★ If the power is turned ON with the connectors still disconnected, unnecessary abnormality displays will be generated.
- 4) When carrying out troubleshooting of circuits (measuring the voltage, resistance, continuity, or current), move the related wiring and connectors several times and check that there is no change in the reading of the tester.
★ If there is any change, there is probably defective contact in the circuit.

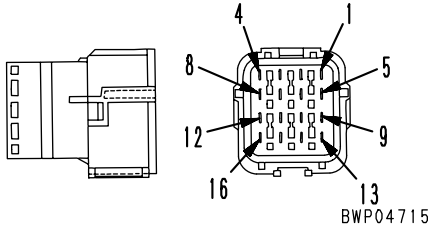
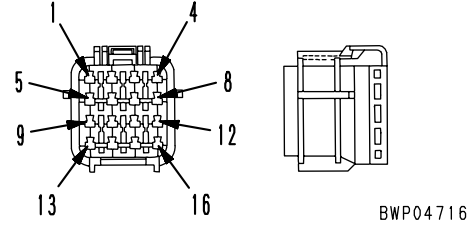
Number of Pins	SWP Type Connector		
	Male (Female housing)	Female (Male housing)	T-adapter Part Number
16	 <p style="text-align: center;">BWP04715</p>	 <p style="text-align: center;">BWP04716</p>	799-601-7320
	Part number: 08055-11681	Part number: 08055-11691	
—	Terminal part number: <ul style="list-style-type: none"> • Wire size: 0.85 • Quantity: 20 pieces • Grommet: black 	Terminal part number: <ul style="list-style-type: none"> • Wire size: 0.85 • Quantity: 20 pieces • Grommet: black 	—
—	Terminal part number: <ul style="list-style-type: none"> • Wire size: 1.25 • Quantity: 20 pieces • Grommet: red 	Terminal part number: <ul style="list-style-type: none"> • Wire size: 1.25 • Quantity: 20 pieces • Grommet: red 	—

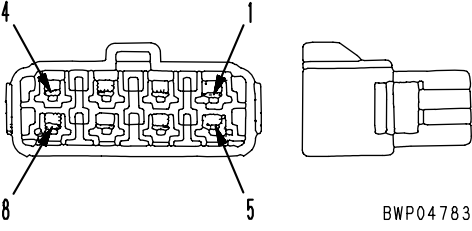
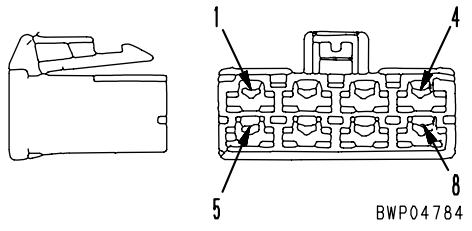
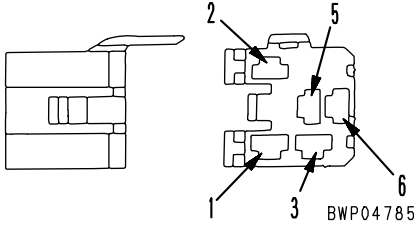
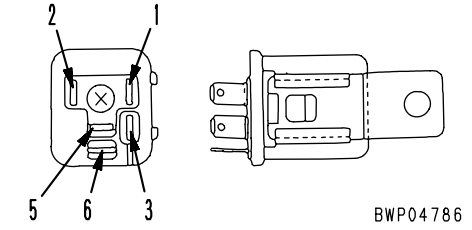
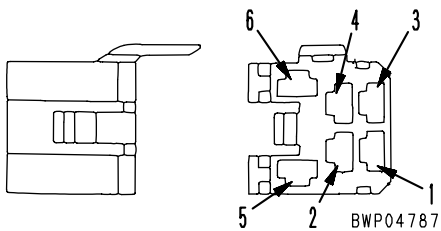
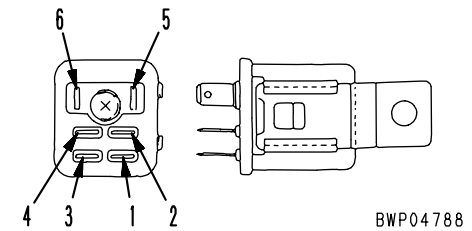
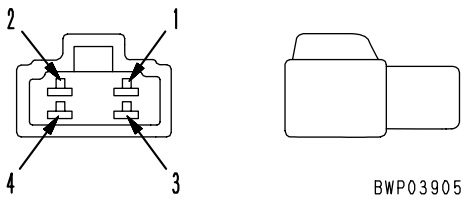
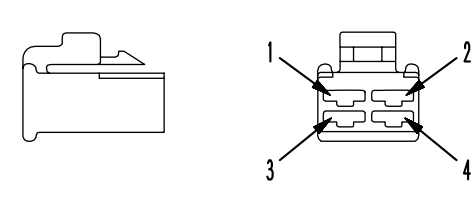
Number of Pins	KES1 Automobile Type Connector		
	Male (Female housing)	Female (Male housing)	T-adapter Part Number
8	 <p>BWP04783</p>	 <p>BWP04784</p>	—
	Part number: 08027-10810 (Natural color) 08027-10820 (Black)		
Number of Pins	Connector for relay (Socket)		
	Male (Female housing)	Female (Male housing)	T-adapter Part Number
5	 <p>BWP04785</p>	 <p>BWP04786</p>	799-601-7360
	—	—	
6	 <p>BWP04787</p>	 <p>BWP04788</p>	799-601-7370
	—	—	
Type (shell size code)	F Type Connector		
	Pin (Male terminal)	Body (Female terminal)	T-adapter Part Number
4	 <p>BWP03905</p>		—
	—	—	

No.	Type	Number of pins	Device name	Address
T15	DT-T	2	Parking brake solenoid	I-4
T17	DT-T	2	Emergency brake pressure switch	J-2
T18	DT-T	2	Parking brake indicator pressure switch	J-2
TEL	DT-T	12	Intermediate connector	P-9

INFORMATION CONTAINED IN TROUBLESHOOTING TABLE

★ The troubleshooting table and the related circuit diagrams contain the following information. Grasp their contents fully before proceeding to actual troubleshooting work.

Action Code	Failure Code	Controller Code	Trouble	Trouble displayed in trouble data
Panel display	Panel display	Panel display		
Description of Trouble	<ul style="list-style-type: none"> Condition when machine monitor or controller detected trouble. 			
Machine monitor or controller Reaction	<ul style="list-style-type: none"> Action to take to protect system or equipment when machine monitor or controller detected trouble. 			
Effect on Machine	<ul style="list-style-type: none"> Condition that appeared as problem on machine when action (given above) was taken by machine monitor or controller. 			
Related Information	<ul style="list-style-type: none"> Information related to troubleshooting or error that occurred. 			

Possible Causes and Standard Values	Causes		Standard Value in Normal State and Remarks on Troubleshooting
	Index	Description	
	1	Probable cause when trouble occurred (the numbers are index numbers and do not indicate the order of priority)	<Data to fill in> <ul style="list-style-type: none"> Normal standard values used to judge probable cause Remarks regarding decision-making <Condition when wiring harness is defective> <ul style="list-style-type: none"> Disconnection There is defective connection of connector or disconnection in wiring harness Short circuit with ground Wiring harness not wired to ground (GND) circuit is in contact with ground (GND) circuit Short circuit with power source Wiring harness not wired to power supply (24 V) circuit is in contact with power supply (24 V) circuit <Points to remember when troubleshooting> 1) Method of displaying connector No. and handling T-adapter Unless there is special instruction, insert or connect the T-adapter as follows <ul style="list-style-type: none"> If there is no indication for the male or female terminal of the connector No., disconnect the connector and insert the T-adapter in both the male and female terminals If there is indication for the male or female terminal of the connector No., disconnect the connector and connect the T-adapter to only the terminal indicated (either the male terminal or female terminal) <Points to remember when troubleshooting> 2) Given order for pin numbers and handling tester lead Unless there is a special instruction, connect tester (+) lead and (-) lead as follows to carry out troubleshooting <ul style="list-style-type: none"> Connect the (+) lead to the wiring harness for the pin No. given first Connect the (-) lead to the wiring harness for the pin No. given last
	2		
	3		
	4		
	5		

Possible Causes and Standard Values	Causes		Standard Value in Normal State and Remarks on Troubleshooting		
	5	Defective HST controller	Between L41 (6) and chassis ground	1) Turn starting switch OFF. 2) Disconnect connector L41. 3) Insert T-adaptor. 4) Connect connector. 5) Turn starting switch ON	
Turn travel speed selector switch 1st				Voltage	2 - 20V
Turn travel speed selector switch 2nd				Voltage	2 - 20V
Turn travel speed selector switch 3rd and 4th				Voltage	2 - 20V
Turn travel speed selector switch 3rd and 4th (10km/h and below)				Voltage	3V and below

Related circuit diagram

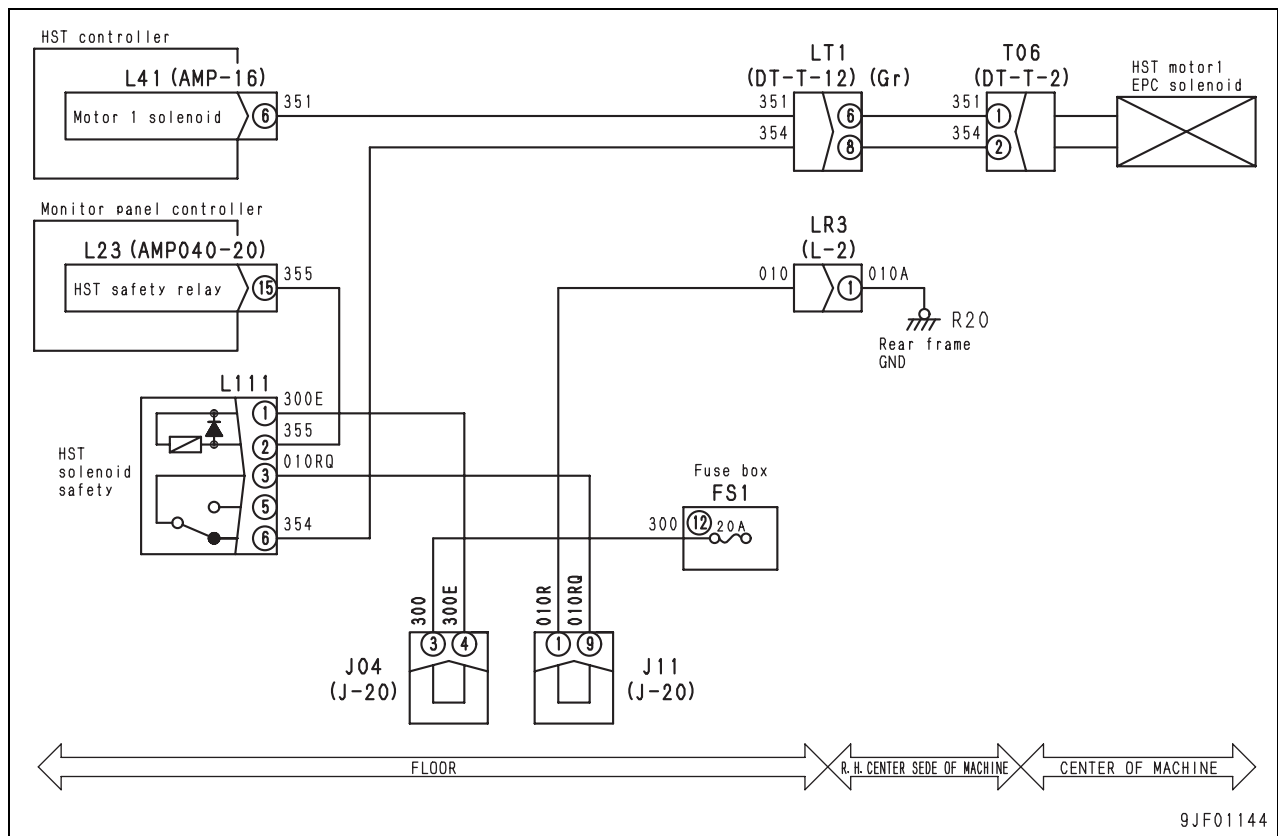

CLICK HERE TO **DOWNLOAD** THE COMPLETE MANUAL

- Thank you very much for reading the preview of the manual.
- You can download the complete manual from: www.heydownloads.com by clicking the link below



- Please note: If there is no response to CLICKING the link, please download this PDF first and then click on it.

CLICK HERE TO **DOWNLOAD** THE COMPLETE MANUAL

Related circuit diagram

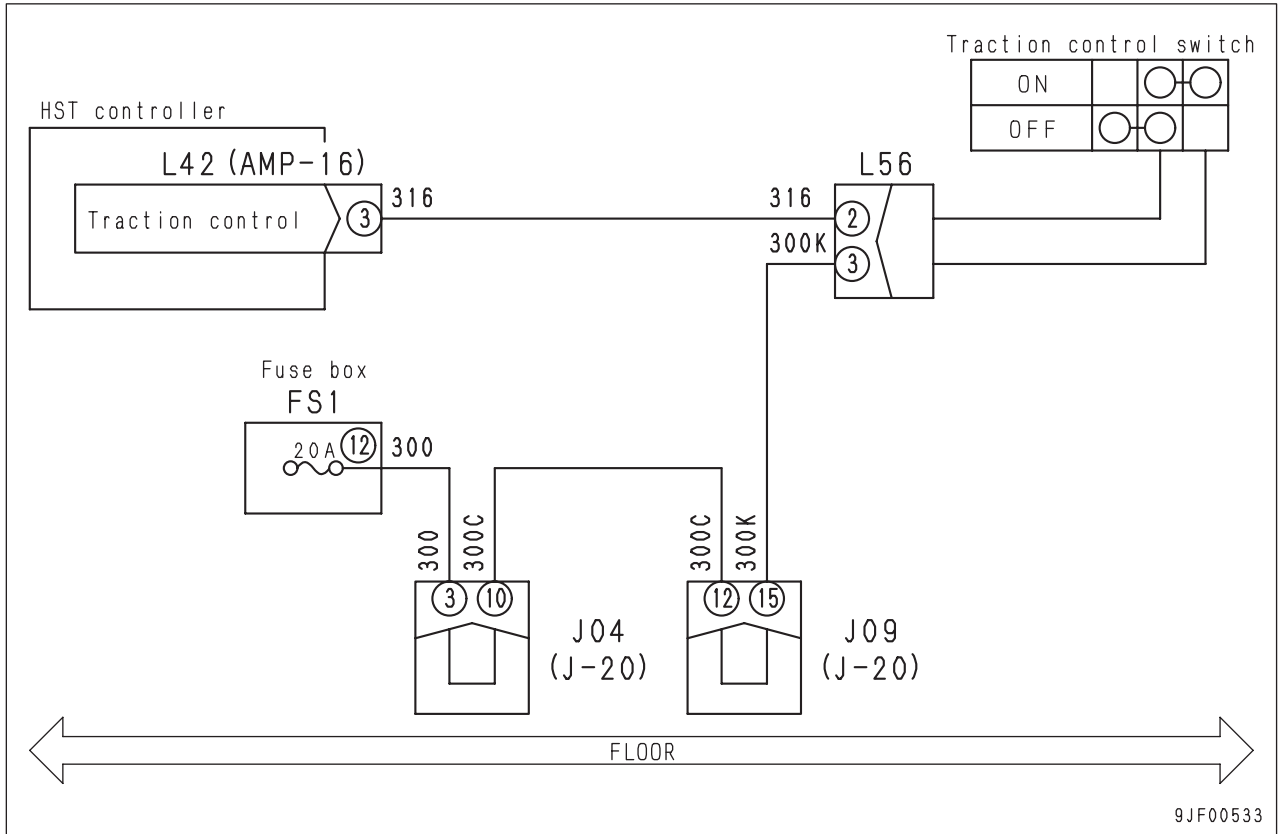

		Causes	Standard value in normal state/Remarks on troubleshooting				
Possible causes and standard value in normal state	4	Defective diode (D05)	1) Turn starting switch OFF. 2) Replace diode (D05) with normal one. 3) Turn starting switch ON.				
			Condition does not become normal.		Diode (D05) is normal		
			Condition becomes normal.		Diode (D05) is defective.		
			Check diode unit.				
			Check continuity from (2) to (1) in diode range.		There is continuity.		
			Check continuity from (2) to (3) in diode range.		There is continuity.		
			Check continuity from (1) to (2) in diode range.		There is not continuity.		
			Check continuity from (1) to (3) in diode range.		There is not continuity.		
			Check continuity from (3) to (2) in diode range.		There is not continuity.		
			Check continuity from (3) to (1) in diode range		There is not continuity.		
	★ Apply (+) pin of circuit tester to left line.						
	5	Defective travel damper controller	1) Turn starting switch OFF. 2) Disconnect connector L14. 3) Connect T-adaptor. 4) Turn starting switch ON.				
			Between L14 (4) and chassis ground	Travel speed: 0 - 5 km/h	Voltage	Max. 1 V	
				Travel speed: Above 6 km/h	Voltage	20 - 30 V	
	6	Short circuit with power source in wiring harness	1) Turn starting switch OFF. 2) Disconnect connectors L09, L110, L14, J08, D05, FL2, and F07. 3) Connect T-adaptor. 4) Turn starting switch ON.				
			Wiring harness between L09 (female) (3) and L110 (female) (3)	Between this wiring harness and chassis ground	Max. 1V (Travel damper is not reset when speed is above 6 km/h and switch is OFF)		
			Wiring harness between L14 (female) (4) and L110 (female) (1)	Between this wiring harness and chassis ground	Max. 1V (Travel damper is not reset when speed is below 5 km/h and switch is ON)		
			Wiring harness between L110 (female) (5) and J08 (14), (15) and D06 (female) (1)	Between this wiring harness and chassis ground	Max. V (Travel damper is not reset under any condition)		
			Wiring harness between L110 (female) (5) and J08 (14), (16) and FL2 (male) (4)	Between this wiring harness and chassis ground	Max. 1V (Travel damper is not reset under any condition)		
			Wiring harness between FL2 (female) (4) and F07 (female) (1)	Between this wiring harness and chassis ground	Max. 1V (Travel damper is not reset under any condition)		

Failure Code [15B0NX] (HST oil filter clogged (NX))

Action Code	Failure Code	Controller Code	Trouble	HST oil filter clogged (NX)
E01	15B0NX	MON		
Description of Trouble	<ul style="list-style-type: none"> When HST oil temperature went above 50oC: signal circuit of HST oil filter clogging sensor changed to CLOSE (connected to GND) 			
Machine monitor or controller Reaction	<ul style="list-style-type: none"> Trigger an alarm. 			
Effect on Machine	<ul style="list-style-type: none"> If it is used as it is, there is danger that dirt will circulated in the HST circuit 			
Related Information				

Possible Causes and Standard Values	Causes		Standard Value in Normal State and Remarks on Troubleshooting			
	1	HST oil filter clogged	<ul style="list-style-type: none"> Clean or replace 			
2	Defective HST oil filter clogging sensor	1) Turn starting switch OFF. 2) Disconnect connector T13.				
		Between T13 and chassis ground	Filter is normal	Resistance	1MΩ and above	
			Filter clogged	Resistance	1Ω and below	
3	Wiring harness ground fault	1) Turn starting switch OFF. 2) Disconnect connector T13.				
		Wiring harness between L23 (Female) (6) and T13	Resistance between L23 (Female) (6), T13 and chassis ground		1MΩ and above	
4	Defective machine monitor	1) Turn starting switch OFF. 2) Disconnect connector L23. 3) Insert T-adapter. 4) Connect connector. 5) Turn starting switch ON.				
		Between L23 (Female) (6) and chassis ground	Filter is normal	Voltage	20 - 30V	
			Filter clogged	Voltage	1V and below	

Related circuit diagram

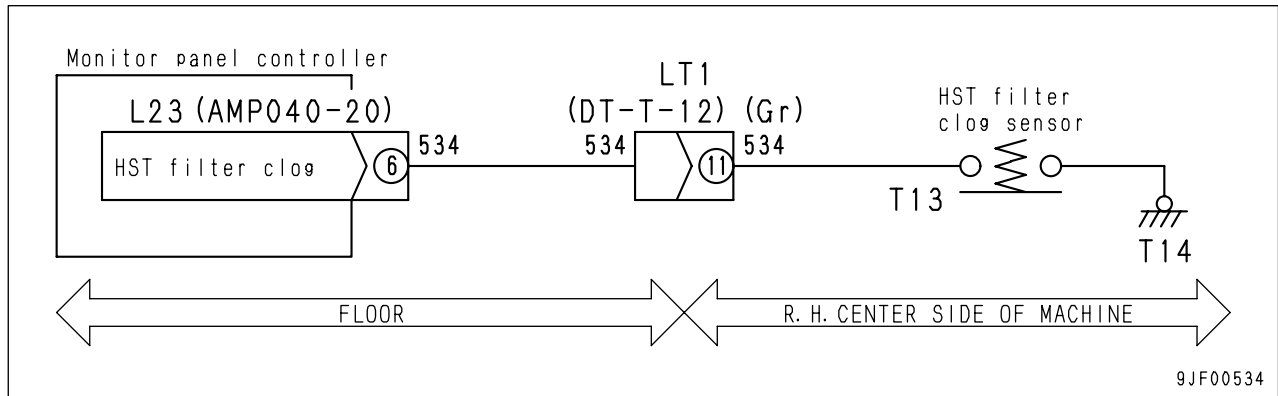

Failure Code [B@BAZK] Lowering of engine oil level (ZK)

Action Code	Failure Code	Controller Code	Trouble	Lowering of engine oil level (ZK)
E01	B@BAZK	MON		
Description of Trouble	<ul style="list-style-type: none"> The engine oil level sensor circuit is OPEN. 			
Machine monitor or controller Reaction	<ul style="list-style-type: none"> None in particular. 			
Effect on Machine	<ul style="list-style-type: none"> The engine oil level is low (The engine may be damaged). 			
Related Information				

Possible Causes and Standard Values	Causes		Standard Value in Normal State and Remarks on Troubleshooting			
	1	Lowering of engine oil level	---			
2	Defective engine oil level sensor	1) Turn starting switch OFF. 2) Disconnect connector E27. 3) Connect T-adaptor.				
		Between E27 (male) (1) and chassis	When oil level is normal	Resistance	Max. 1 Ω	
3	Short circuit with chassis ground in wiring harness	1) Turn starting switch OFF. 2) Disconnect connectors L23 and E27. 3) Connect T-adaptor.				
		Wiring harness between L23 (female) (20) and E27	Resistance between L23 (female) (20), E27 and chassis ground		Min. 1 MΩ	
4	Defective machine monitor	1) Turn starting switch OFF. 2) Disconnect connector L23. 3) Connect T-adaptor. 4) Connect connector. 5) Turn starting switch ON.				
		Between L23 (female) (20) and chassis ground	When oil level is normal	Voltage	Max. 1 V	
			When oil level is insufficient (low)	Voltage	20 - 30 V	

Related circuit diagram

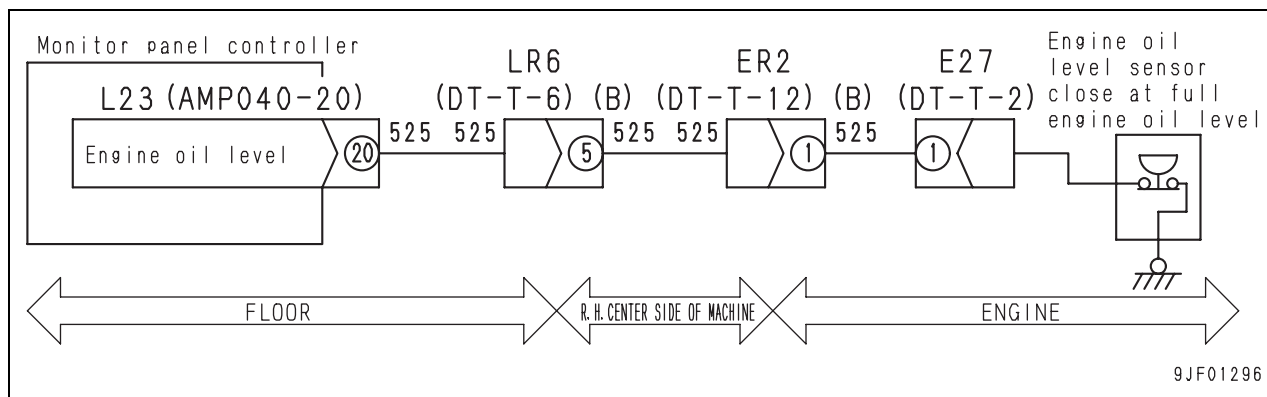

Related circuit diagram

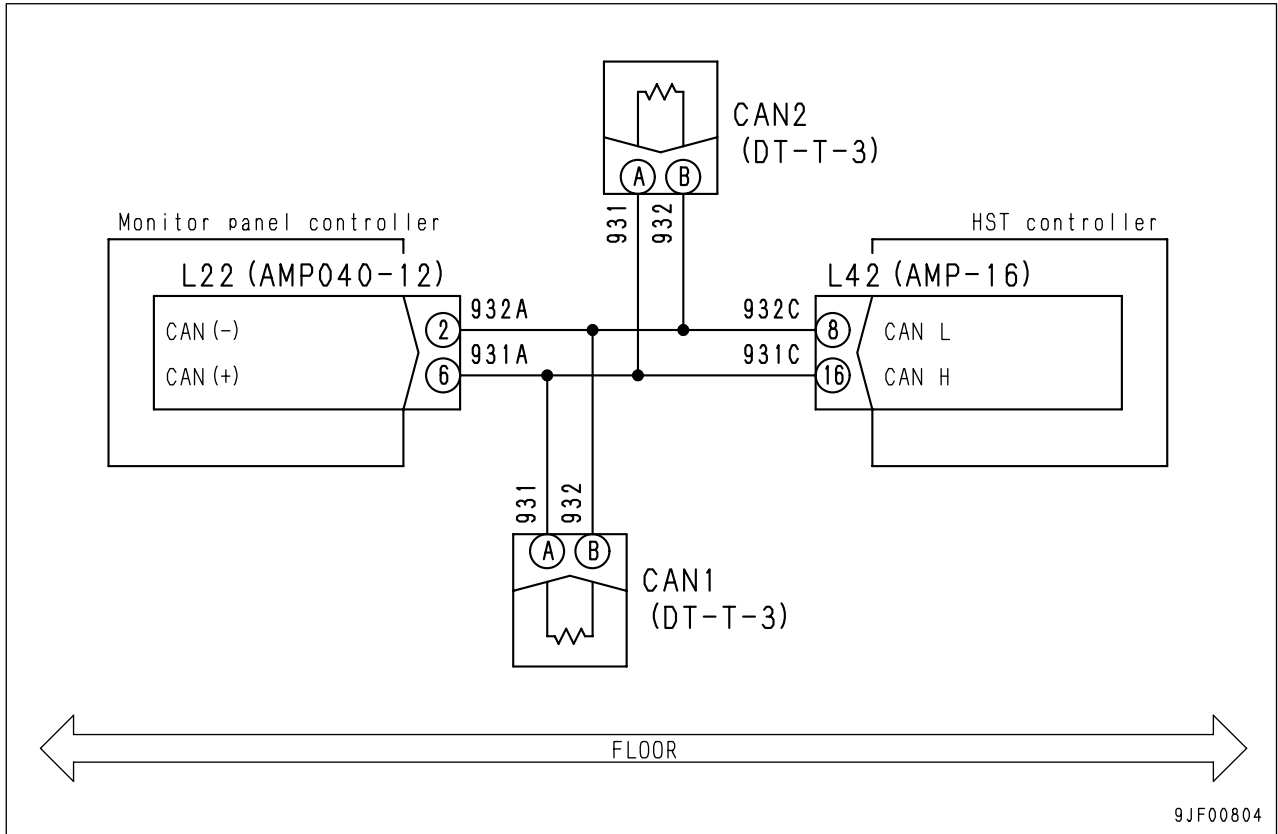

Failure Code [DGH1KX] (HST oil temperature sensor system failure (KX))

Action Code	Failure Code	Controller Code	Trouble	HST oil temperature sensor system failure (KX)
E01	DGH1KX	MON		
Description of Trouble	<ul style="list-style-type: none"> The HST oil temperature sensor input voltage is less 0.98V. 			
Machine monitor or controller Reaction	<ul style="list-style-type: none"> Activates an alarm. 			
Effect on Machine	<ul style="list-style-type: none"> The HST oil temperature gauge is in the MAX position. 			
Related Information	<ul style="list-style-type: none"> The HST oil temperature is displayed by real-time monitoring code 30100. 			

Possible Causes and Standard Values	Causes		Standard Value in Normal State and Remarks on Troubleshooting			
		1	Defective HST oil temperature sensor	1) Turn starting switch OFF. 2) Disconnect connector T10. 3) Connect T-adapter.		
Between T10 (Male) (1) and (2)				Normal temperature (25°C).	Resistance	35 - 50kΩ
				When 100°C	Resistance	3.1 - 4.5kΩ
2		Wiring harness ground fault	1) Turn starting switch OFF. 2) Disconnect Connectors L21, T10. 3) Connect T-adapter.			
			Wiring harness between L21 (Female) (14) and T10 (Female) (1)	Resistance between L21 (Female) (14), T10 (Female) (1) and chassis ground		1MΩ and above
3		Defective machine monitor	1) Turn starting switch OFF. 2) Disconnect connector L21. 3) Insert T-adapter. 4) Connect connector. 5) Turn starting switch ON.			
	Between L21 (Female) (14) and chassis ground		Normal temperature (25°C).	Resistance	35 - 50kΩ	
			When 100°C	Resistance	3.1 - 4.5kΩ	

Related circuit diagram

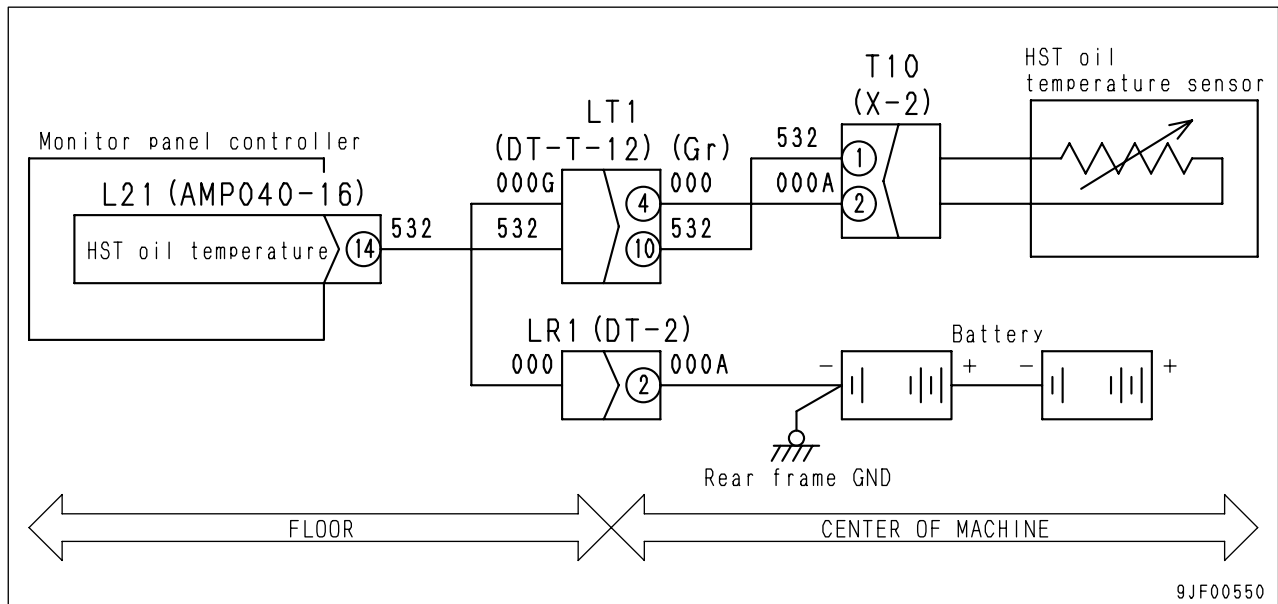

Troubleshooting Code [MON-3] (The engine coolant temperature caution lamp does not light ON, or after the engine starts, the engine coolant temperature gauge does not rise.)

Action Code	Failure Code	Controller Code	Trouble	The engine coolant temperature caution lamp does not light ON, or after the engine starts, the engine coolant temperature gauge does not rise.
-	-	-		
Description of Trouble	<ul style="list-style-type: none"> The engine coolant temperature sensor circuit is always in the OPEN state. 			
Machine monitor or controller Reaction	<ul style="list-style-type: none"> No reaction. 			
Effect on Machine	<ul style="list-style-type: none"> The engine coolant temperature caution lamp does not light ON. After the engine starts, the engine coolant temperature gauge does not rise. 			
Related Information	<ul style="list-style-type: none"> The engine coolant temperature is displayed by real-time monitoring code 04101. 			

Possible Causes and Standard Values	Causes		Standard Value in Normal State and Remarks on Troubleshooting			
		1	Defective engine coolant temperature sensor	1) Turn starting switch OFF. 2) Disconnect connector E14. 3) Connect T-adapter.		
Between E14 (Male) (1) and (2)				Normal temperature (25°C)	Resistance	35 - 50kΩ
				When 100°C	Resistance	3.1 - 4.5kΩ
2		Wiring harness discontinuity (Disconnection or defective contact)	1) Turn starting switch OFF. 2) Disconnect Connectors L21, E14. 3) Connect T-adapter.			
			Wiring harness between L21 (Female) (16) and E14 (Female) (1)	Resistance	1Ω and below	
			Wiring harness between E14 (Female) (2) and chassis ground	Resistance	1Ω and below	
3	Defective machine monitor	1) Turn starting switch OFF. 2) Disconnect connector L21. 3) Connect T-adapter.				
		Between L21 (Female) (16) and Chassis ground	Normal temperature (25°C)	Resistance	35 - 50kΩ	
			When 100°C	Resistance	3.1 - 4.5kΩ	

Related circuit diagram

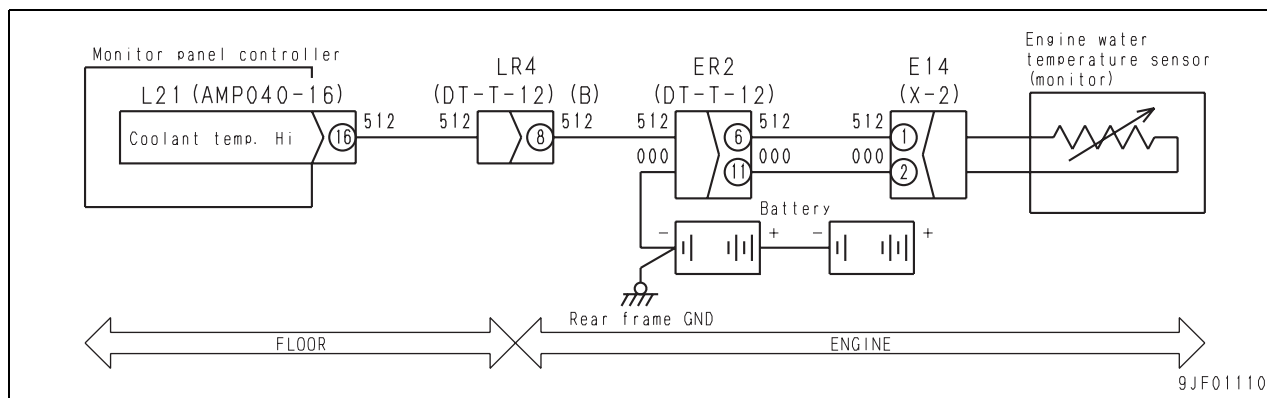

INFORMATION CONTAINED IN TROUBLESHOOTING TABLE

★ The troubleshooting table and the related circuit diagrams contain the following information. Grasp their contents fully before proceeding to actual troubleshooting work.

Action Code	Failure Code	Controller Code	Trouble	Trouble displayed in trouble data
Panel display	Panel display	Panel display		
Description of Trouble	<ul style="list-style-type: none"> Condition when machine monitor or controller detected trouble. 			
Machine monitor or controller Reaction	<ul style="list-style-type: none"> Action to take to protect system or equipment when machine monitor or controller detected trouble. 			
Effect on Machine	<ul style="list-style-type: none"> Condition that appeared as problem on machine when action (given above) was taken by machine monitor or controller. 			
Related Information	<ul style="list-style-type: none"> Information related to troubleshooting or error that occurred. 			

Possible Causes and Standard Values	Causes		Standard Value in Normal State and Remarks on Troubleshooting
	Index	Description	
	1	Probable cause when trouble occurred (the numbers are index numbers and do not indicate the order of priority)	<Data to fill in> <ul style="list-style-type: none"> Normal standard values used to judge probable cause Remarks regarding decision-making <Condition when wiring harness is defective> <ul style="list-style-type: none"> Disconnection There is defective connection of connector or disconnection in wiring harness Short circuit with ground Wiring harness not wired to ground (GND) circuit is in contact with ground (GND) circuit Short circuit with power source Wiring harness not wired to power supply (24 V) circuit is in contact with power supply (24 V) circuit <Points to remember when troubleshooting> 1) Method of displaying connector No. and handling T-adapter Unless there is special instruction, insert or connect the T-adapter as follows <ul style="list-style-type: none"> If there is no indication for the male or female terminal of the connector No., disconnect the connector and insert the T-adapter in both the male and female terminals If there is indication for the male or female terminal of the connector No., disconnect the connector and connect the T-adapter to only the terminal indicated (either the male terminal or female terminal) <Points to remember when troubleshooting> 2) Given order for pin numbers and handling tester lead Unless there is a special instruction, connect tester (+) lead and (-) lead as follows to carry out troubleshooting <ul style="list-style-type: none"> Connect the (+) lead to the wiring harness for the pin No. given first Connect the (-) lead to the wiring harness for the pin No. given last
	2		
	3		
	4		
	5		

Related circuit diagram

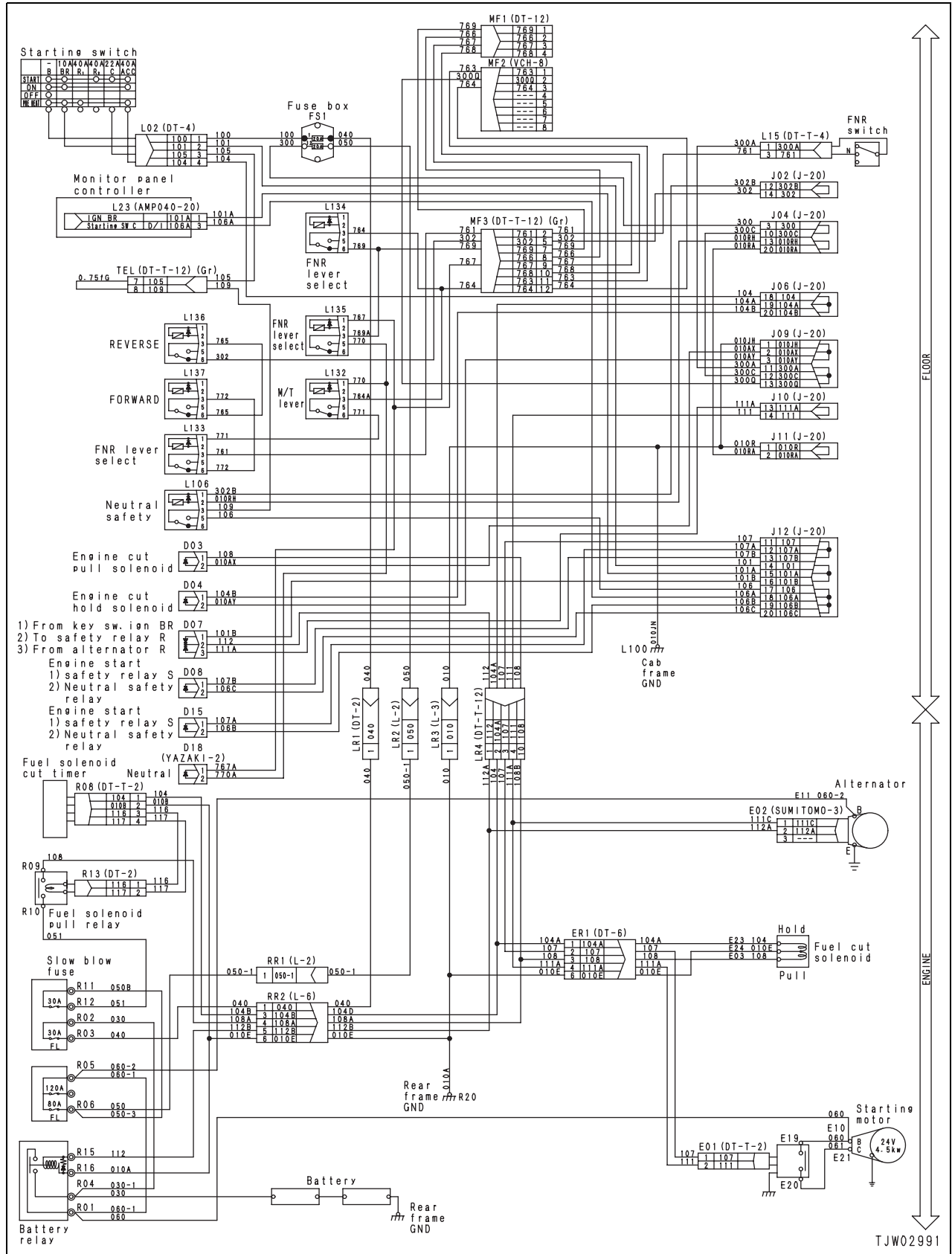

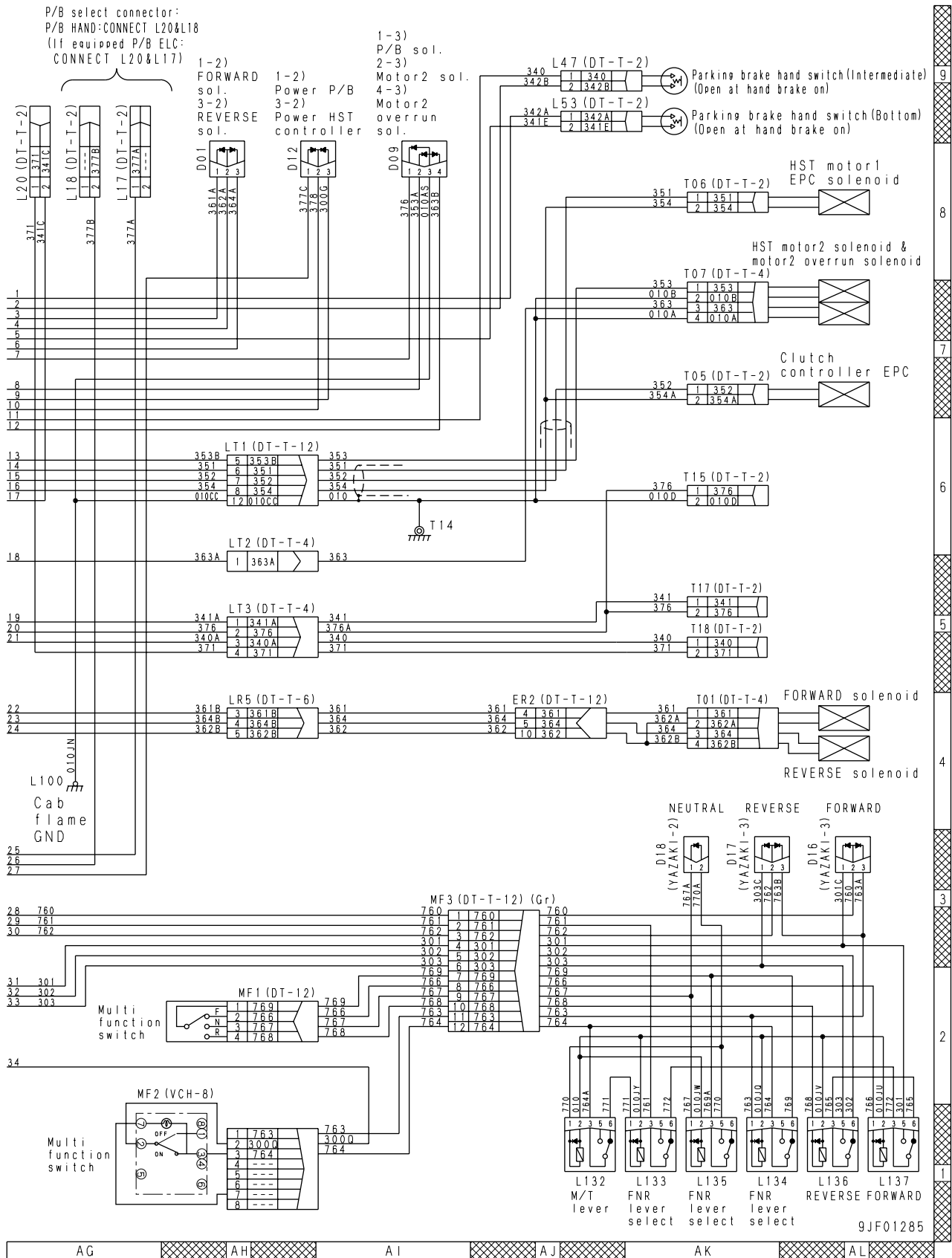

		Causes	Standard value in normal state/Remarks on troubleshooting		
Possible causes and standard value in normal state	3	Defective forward relay (L108)	1) Turn starting switch OFF. 2) Replace L108 with normal relay.		
			When forward relay (L108) is replaced, does condition become normal?	No	Relay (L108) is normal.
				Yes	Relay (L108) is defective.
			1) Turn starting switch OFF. 2) Disconnect connector L108. 3) Check relay unit.		
			Between L108 (male) (1) and (2)	Resistance	200 - 400Ω
			1) Turn starting switch OFF. 2) Disconnect connector L108 3) Check relay unit. 4) Apply normal voltage between L108 (male) (1) and (2).		
			Between L108 (male) (3) and (5)	When 24 V is applied between and (1) and (2)	Resistance
		When normal voltage is not applied between and (1) and (2)	Resistance	Min. 1 MΩ	
	4	Defective forward solenoid	1) Turn starting switch OFF. 2) Disconnect connector T01. 3) Connect T-adapter.		
			Between T01 (male) (1) and (2)	Resistance	30 - 60Ω
			Between T01 (male) (1), (2) and chassis ground	Resistance	Min. 1 MΩ
	5	Disconnection in wiring harness (Disconnection in wiring harness or defective contact)	1) Turn starting switch OFF. 2) Disconnect connectors T01, L15, L108, and L112 and fuse (FS1). 3) Connect T-adapter.		
			Wiring harness between L15 (female) (2) and L108 (female) (1)	Resistance	Max. 1 Ω
			Wiring harness between L108 (female) (2) and chassis ground	Resistance	Max. 1 Ω
			Wiring harness between fuse FS1 (12) and L108 (female) (3)	Resistance	Max. 1 Ω
			Wiring harness between L108 (female) (5) and T01 (female) (1)	Resistance	Max. 1 Ω
			Wiring harness between T01 (female) (2) and L112 (female) (5)	Resistance	Max. 1 Ω
	6	Grounding fault in wiring harness	1) Turn starting switch OFF. 2) Disconnect connectors T01, L15, L22, and L108 3) Connect T-adapter.		
			Wiring harness between L15 (female) (2) and L22 (female) (10)	Resistance between L15 (female) (2), L22 (female) (10) and chassis ground	Min. 1 MΩ
			Wiring harness between L15 (female) (2) and L108 (female) (1)	Resistance between L15 (female) (2), L108 (female) (1) and chassis ground	Min. 1 MΩ
			Wiring harness between L108 (female) (5) and D01 (female) (1)	Resistance between L108 (female) (5), D01 (female) (1) and chassis ground	Min. 1 MΩ
Wiring harness between L108 (female) (5) and T01 (female) (1)			Resistance between L108 (female) (5), T01 (female) (1) and chassis ground	Min. 1 MΩ	
Wiring harness between fuse (FS1) (12) and L15 (female) (1), L108 (female) (3)			Resistance between fuse (FS1) (12), L15 (female) (1), L108 (female) (3) and chassis ground	Min. 1 MΩ	
★ In all of these cases, the fuse is broken.					

Related circuit diagram

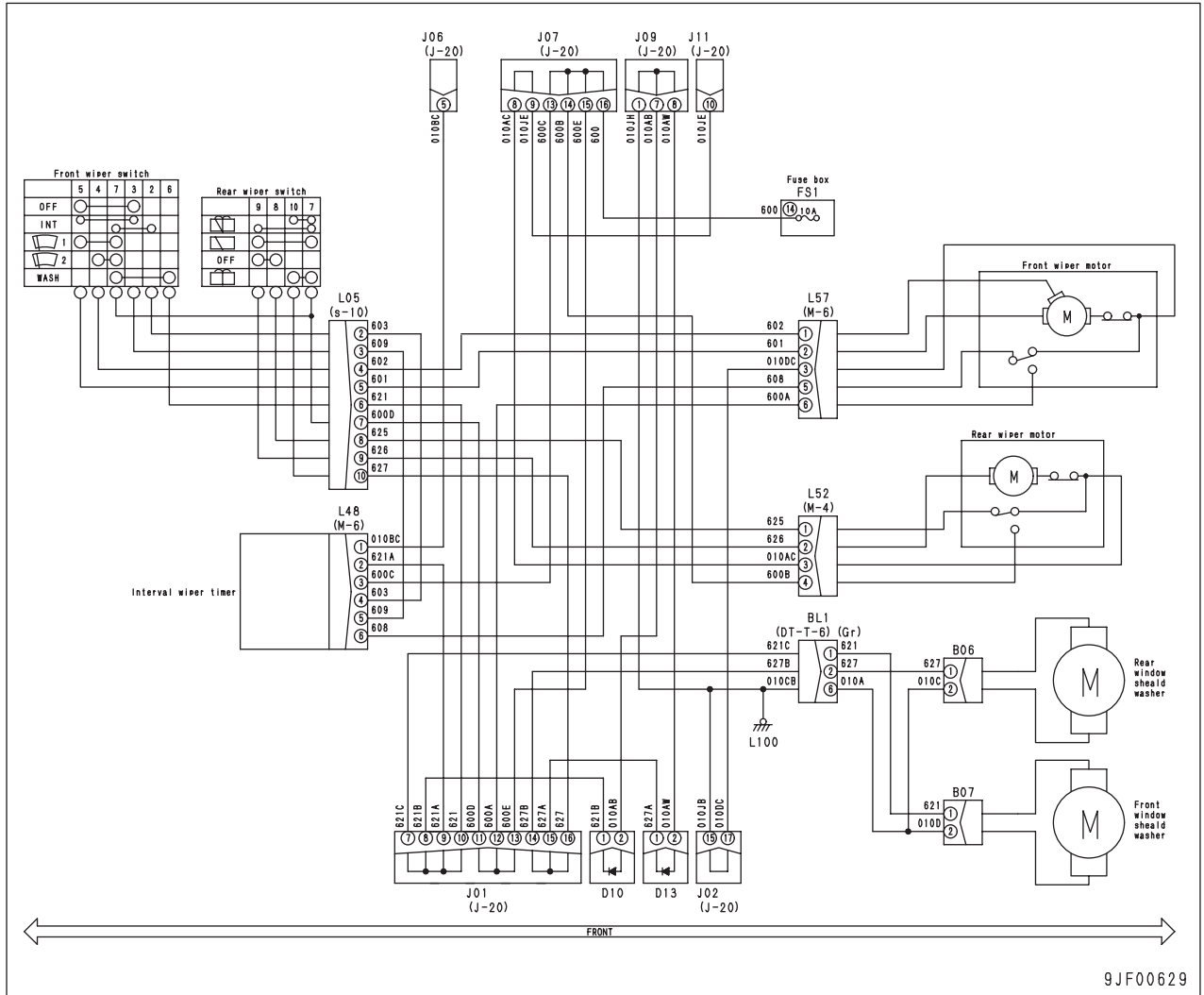

Related circuit diagram

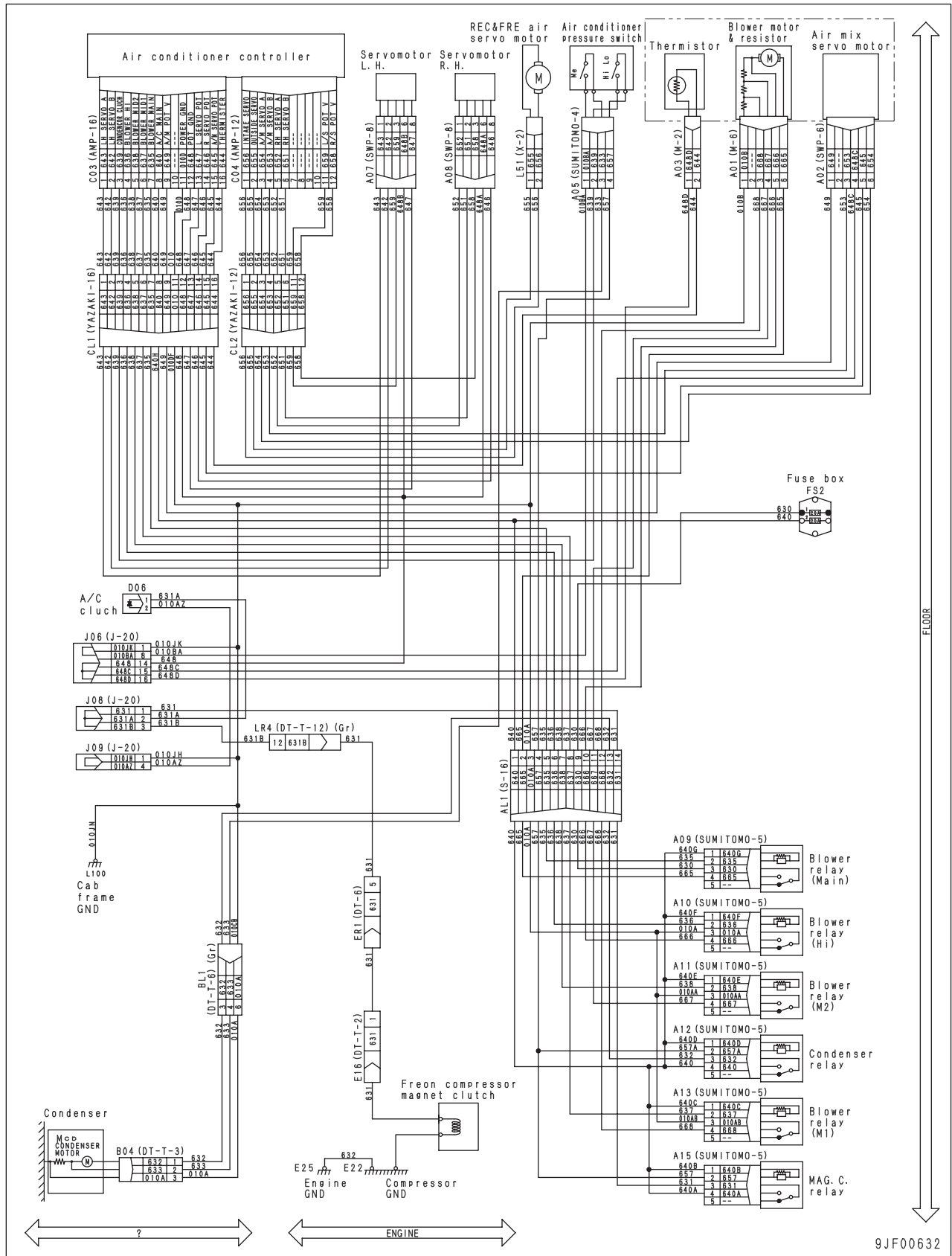

i) Water leaks

Action Code	Error code	Controller Code	Trouble	Air conditioner is defective i) Water leaks
-	-	-		
Contents of trouble	<ul style="list-style-type: none"> Water leaks. 			
Action of machine monitor	<ul style="list-style-type: none"> --- 			
Problem that appears on machine	<ul style="list-style-type: none"> AWater leaks. 			
Related information	-			

Possible causes and standard value in normal state	Causes		Standard value in normal state/Remarks on troubleshooting
		1	Clogging of water drain opening in air conditioner unit
2		Clogging, bend, defective installation, or hole of drain hose of air conditioner unit	<ul style="list-style-type: none"> Check. If abnormality is detected, repair or replace.
3		Breakage (Cracking) of air conditioner unit case	<ul style="list-style-type: none"> Check. If breakage (cracking) is detected, repair or replace.
4		Defective mounting bolt (screw) of air conditioner unit case	<ul style="list-style-type: none"> Check. If abnormality is detected, repair or replace.
5		Defective joint of hot-water circuit piping	<ul style="list-style-type: none"> Check. If abnormality is detected, repair or replace.
6		Defective heater core	<ul style="list-style-type: none"> Check. If abnormality is detected, repair or replace.
7		Defective water valve	<ul style="list-style-type: none"> Check. If abnormality is detected, repair or replace.

H-4 Engine stalls when traveling or engine speed drops excessively

Ask the operator about the following:

- Was there any problem before?
→ Dirt in HST pump, motor related equipment

Inspection before diagnosis

- Is there any external oil leak found around the hydraulic piping, pump and motor?

			Cause		
			HST pump	HST motor 2	Others
			a	b	c
			DA valve	Inclination stopper solenoid valve (SOLb)	Inclination control solenoid valve
No.	Diagnosis	Remedy	△ X	△ X	△ X
1	Engine stalls when traveling or engine speed drops excessively		○	○	○
2	Machine moves when the direction the lever is at F or R and engine is at Li		○		

H-18 When the control lever is switched from "HOLD" to "RAISE," the lift arm falls temporarily

Check of Phenomenon

- When the control lever is switched from "HOLD" to "RAISE" gradually at low idling of the engine, the lift arm falls temporarily due to its own weight. When the control lever is completely set to "RAISE," the lift arm returns to normal.

Cause

- Improper adhesion of lift arm spool check valve of the work equipment valve

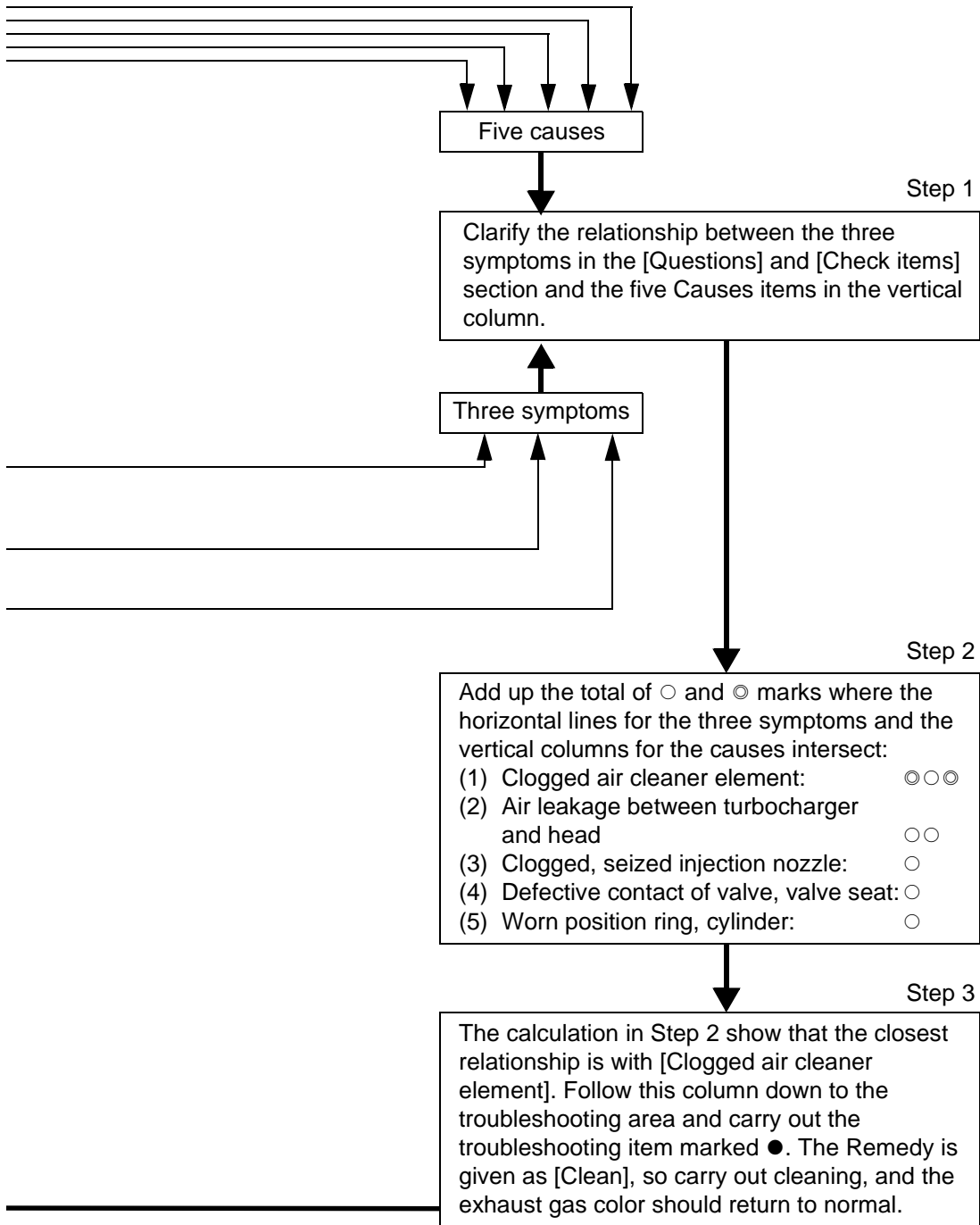

S-7 Exhaust smoke is black (Incomplete combustion)

General causes why exhaust smoke is black

- Insufficient intake of air
- Improper condition of fuel injection
- Excessive injection of fuel

		Causes										
		Seized turbocharger, interference	Clogged air cleaner element	Worn piston ring, cylinder	Clogged injection nozzle, defective spray	Improper injection timing	Improper injection pump (excessive injection)	Crushed, clogged muffler	Leakage of air between turbocharger and head	Defective contact of valve and valve seat	Defective injection pump (rack, plunger seized)	
Questions	Confirm recent repair history											
	Degree of use of machine	Operated for long period	△	△	△				△			
	Color of exhaust gas	Suddenly became black	○		○						○	
		Gradually became black		○	○				○			
		Black under light load			○							
	Engine oil must be added more frequently			○								
	Power was lost	Suddenly	○		○			○			○	
		Gradually		○	○				○	○		
	Non-specified fuel is being used				○						○	
	Noise of interference is heard from around turbocharger		○									
	Dust indicator lamp is red		○									
	Blow-by gas excessive			○								
	Engine pickup is poor and combustion is irregular		○		○		○	○	○		○	
	When exhaust manifold is touched immediately after starting engine, temperature of some cylinders is low				○						○	
	Timing lock on fuel injection pump does not match					○						
Seal on injection pump has come off						○						
Clanging sound is heard from around cylinder head							○					
Check items	Exhaust noise is abnormal	○		○				○				
	Muffler is crushed							○				
	Leakage of air between turbocharger and head, loose clamp								○			
	Troubleshooting	When turbocharger is rotated by hand, it is found to be heavy	●									
		When air cleaner element is inspected directly, it is found to be clogged		●								
		When compression pressure is measured, it is found to be low			●					●		
		Speed does not change when operation of certain cylinders is stopped				●						
		When check is made using delivery method, injection timing is found to be incorrect					●					
		Injection pump test shows that injection amount is incorrect						●				
		When valve clearance is checked directly, it is found to be outside standard value							●			
		When muffler is removed, exhaust color returns to normal								●		
		When control rack is pushed, it is found to be heavy, or does not return									●	
	Remedy	Replace	Clean	Replace	Replace	Adjust	Adjust	Adjust	Replace	Correct	Replace	Replace

30 DISASSEMBLY AND ASSEMBLY

How to read this manual	30 - 2	Removal, installation of operator's cab assembly	30 - 185
Precautions when carrying out operation.	30 - 4	Removal, installation of operator's cab glass (Stuck glass)	30 - 191
Special tool list	30 - 6	Removal, installation of center hinge pin	30 - 199
Sketch of special tools	30 - 9	Removal, installation of counterweight	30 - 210
Removal, installation of fuel injection pump assembly.	30 - 14	Removal, installation of air conditioner unit assembly	30 - 212
Removal, installation of nozzle holder assembly.	30 - 18	Removal, installation of air conditioner compressor assembly	30 - 215
Removal, installation of cylinder head assembly.	30 - 20	Removal, installation of monitor panel	30 - 216
Removal, installation of engine assembly	30 - 28	Removal, installation of HST controller assembly	30 - 220
Removal, installation of radiator assembly	30 - 35		
Removal, installation of air aftercooler.	30 - 36		
Removal, installation of hydraulic oil cooler assembly.	30 - 38		
Removal, installation of cooling fan and fan motor assembly	30 - 40		
Removal, installation of fuel tank assembly.	30 - 42		
Removal, installation of transfer.	30 - 44		
Disassembly, assembly of transfer assembly	30 - 46		
Removal, installation of parking brake assembly.	30 - 66		
Disassembly, assembly of parking brake assembly.	30 - 68		
Removal, installation of front axle assembly	30 - 73		
Removal, installation of rear axle assembly.	30 - 75		
Disassembly, assembly of axle housing assembly.	30 - 78		
Disassembly, assembly of differential assembly.	30 - 91		
Removal, installation of HST pump and 4-gear pump assembly	30 - 115		
Removal, installation of HST motor 1 assembly.	30 - 118		
Removal, installation of HST motor 2 assembly	30 - 120		
Removal, installation of work equipment control valve assembly	30 - 122		
Removal, installation of travel damper valve assembly (If equipped)	30 - 124		
Removal, installation of hydraulic tank assembly.	30 - 126		
Removal, installation of work equipment assembly.	30 - 128		
Disassembly and assembly of HST pump assembly.	30 - 135		
Disassembly and assembly of HST motor assembly.	30 - 162		
Disassembly, assembly of hydraulic cylinder assembly.	30 - 178		

Note: Komatsu cannot accept any responsibility for special tools manufactured according to these sketches.
H2 Seal support

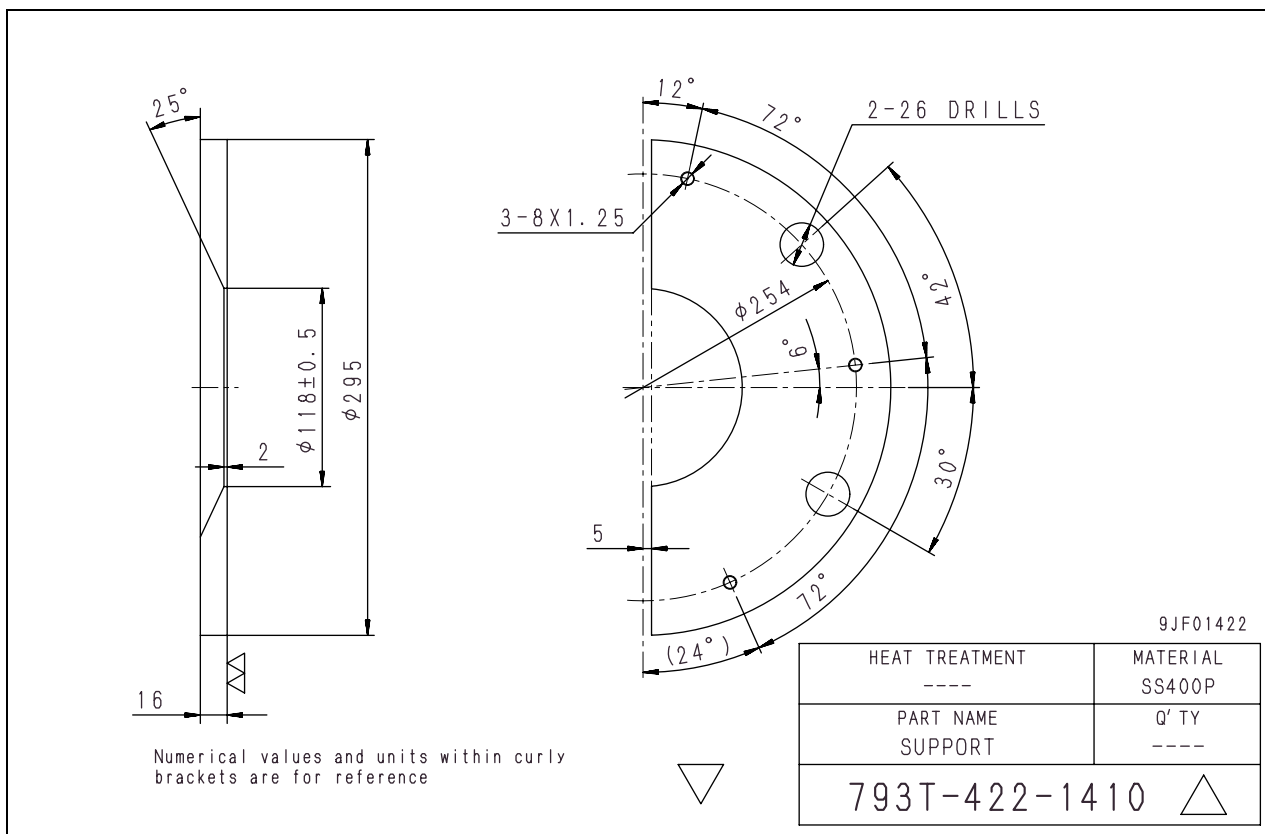

H2 Seal support

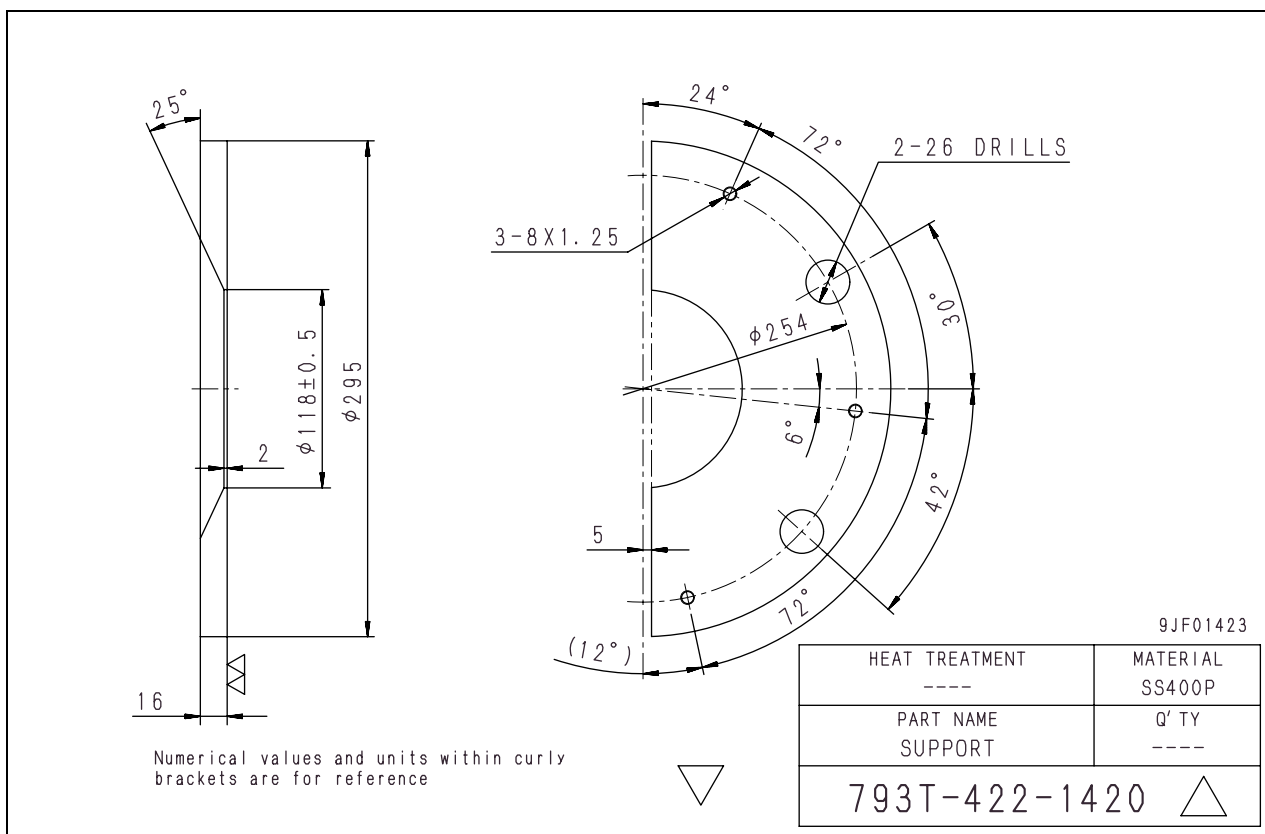

INSTALLATION

- Carry out installation in the reverse order to removal.

[*1]

-  Fuel injection tube nut (on injection pump side): **24 ± 4 Nm {2.45 ± 0.41 kgm}**
Fuel injection tube nut (on nozzle holder side): **30 ± 5 Nm {3.06 ± 0.51 kgm}**

[*2]

-  Spill tube joint bolt: **9 Nm {0.9 kgm}**

[*3]

-  Nozzle holder:
60 Nm ± 9 Nm {6.1 ± 0.9 kgm}

- **Bleeding air**
Bleed air from the fuel system.

- 10) Remove 2 condenser mounting bolts (9) from each side.
- ★ Lower the condenser onto the engine without disconnecting the air conditioner piping.

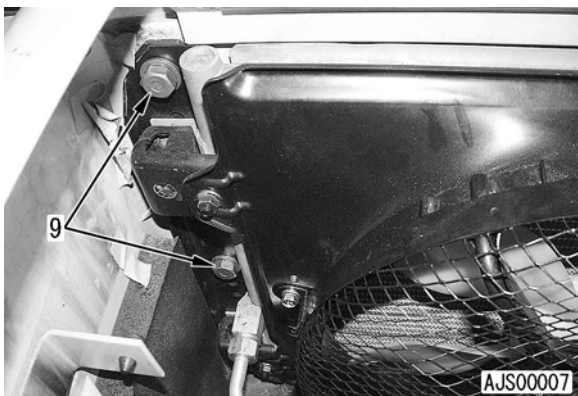

- 11) Disconnect reservoir tank hose (107) and connector BR1 (106).
- 12) Remove the 2 lower mounting bolts of rubber (108) at the rear of the engine.

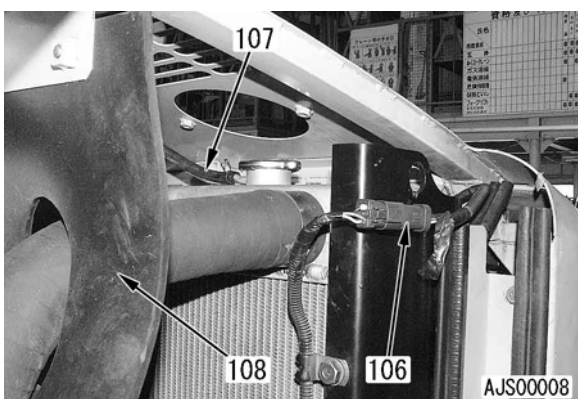

- 13) Open grille (11) and fan guard (12).

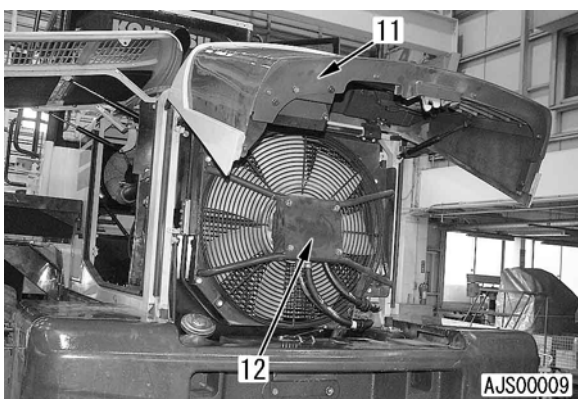

- 14) Remove fuel tank air bleeding hose (13) from clamp (105).



- 15) Remove right and left covers (14).



- 16) Remove 3 engine hood mounting bolts (15) from each side.

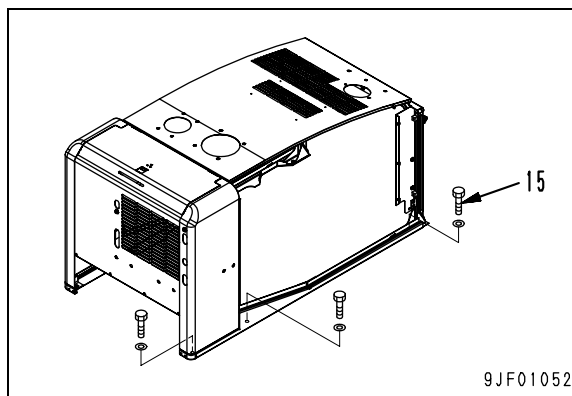

6. Raise oil cooler (9) and pull it out to the left.
★ Take care not to damage the core.



INSTALLATION

- Carry out installation in the reverse order to removal.

[*1]

 Air hose clamp:
10.5 ± 0.5 Nm {107 ± 5 kgcm}

- **Refilling with oil (Hydraulic tank)**
Add oil through the oil filler to the specified level. Run the engine to circulate the oil through the system. Then, check the oil level again.

10. Clutch discs, plates, and springs

- 1) Remove 7 discs (22), 8 plates (23), and 7 wave springs (24).

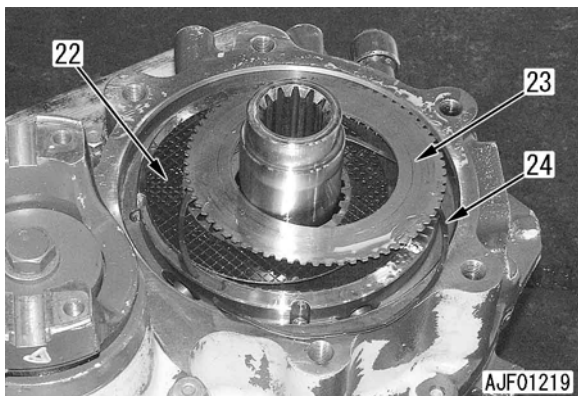

- 2) Remove end plate (25).

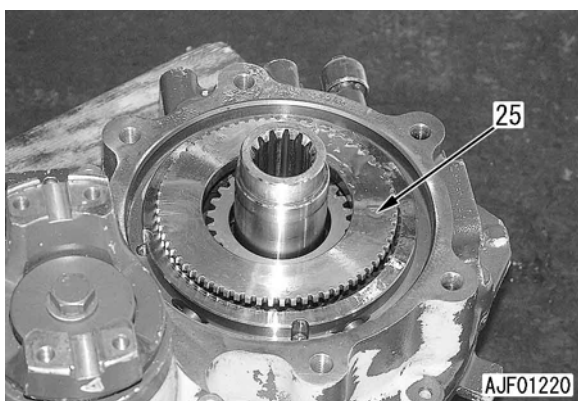

11. Coupling

- 1) Remove the mounting bolts and holder (26).
- 2) Remove coupling (27).



12. Cage assembly

- 1) Remove the mounting bolts. Using forcing screws [6], remove cage assembly (28).

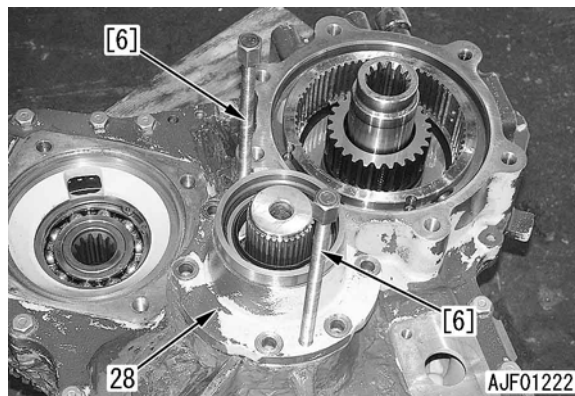

- 2) Remove shims (29).
 - ★ Check the thickness and quantity of the shims.



- 3) Remove dust seal (30) and oil seal (31) from cage (32).
- 4) Remove outer race (33).

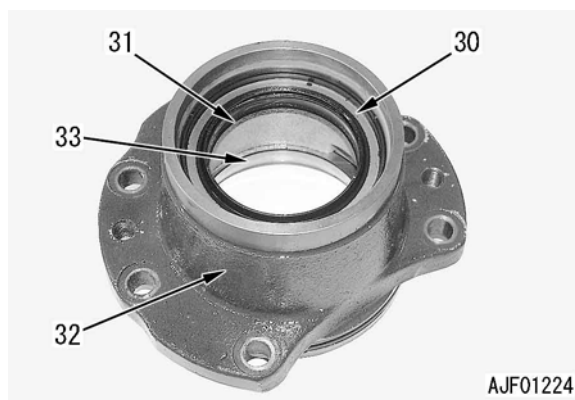

13. Clutch housing

- 1) Install snap ring (84) to the front case.
- 2) Install clutch housing (81) and 3 pins (82).

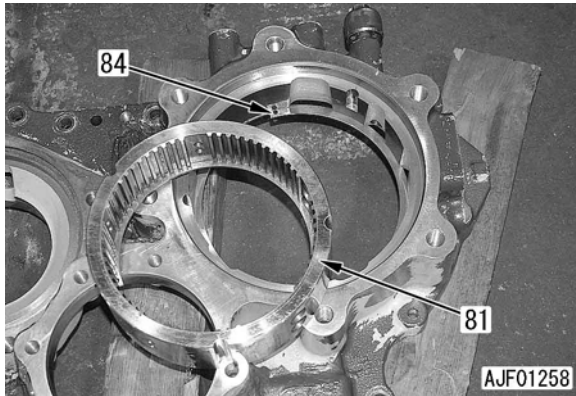

- 3) Install snap ring (83)

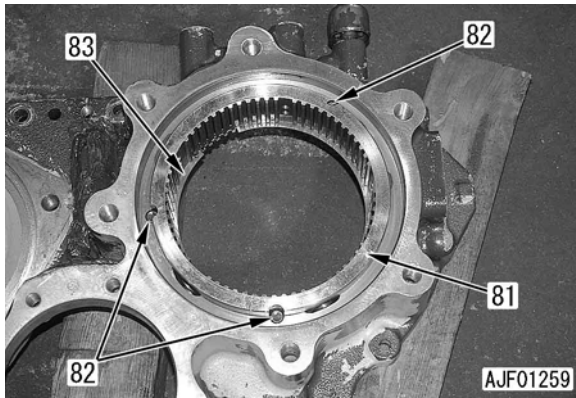

14. Front case

- ★ Use the front case and rear case as an assembly.
 - ★ When installing the cases, match the match marks on their tops to each other.
- 1) Apply gasket sealant to the rear case according to the following procedure.
 - ★ Apply the gasket sealant to forcing screw contact part (a), similarly to the dimensions for each bolt hole.
 - ★ Apply the gasket sealant so that dimensions (b) and (c) will be the same respectively.
 - ★ Apply the gasket sealant so that dimension (e) x dimension (f) will be 2 - 5 mm.



Gasket sealant:
ThreeBond 1207B or equivalent

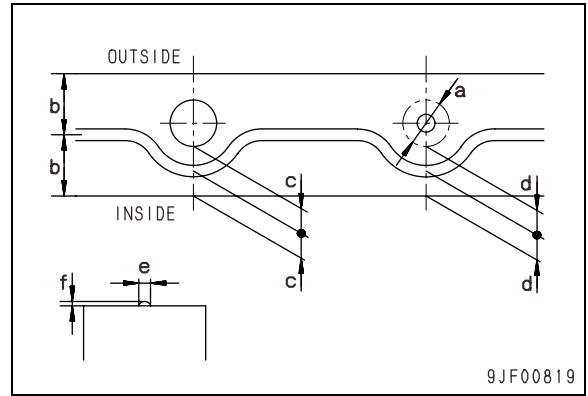

- 2) Set guide pin [26] and install front case (35).

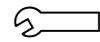

Mounting bolt:
98 - 123 Nm {10 - 12.5 kgm}

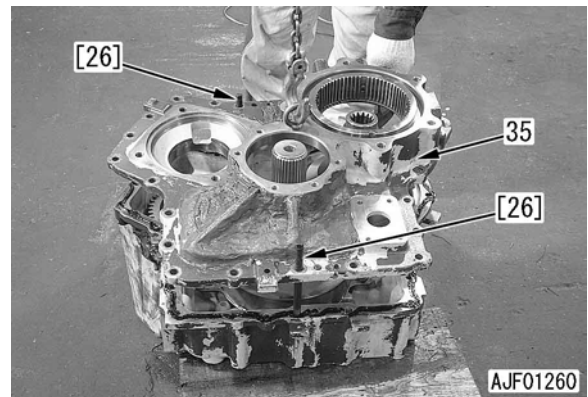

- 3) Install snap ring (86) on the HST motor 2 side.

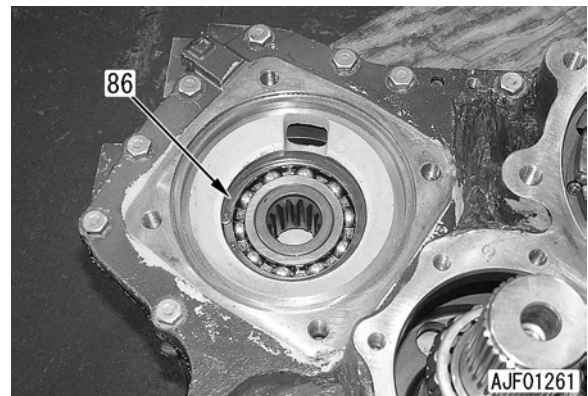

4. Ball

- 1) Remove 6 balls (9).

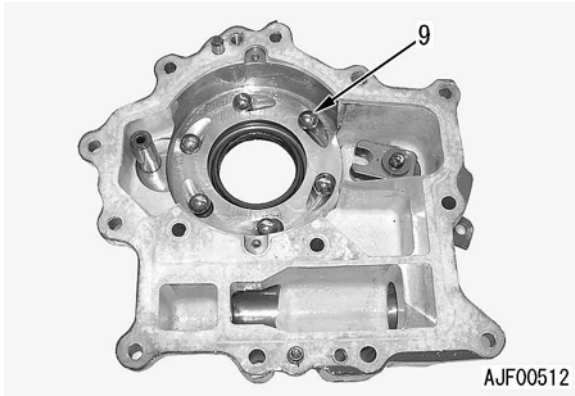

6. Pin

- 1) Remove pin (12).

7. Dust seal and oil seal

- 1) Remove dust seal (13) and oil seal (14).

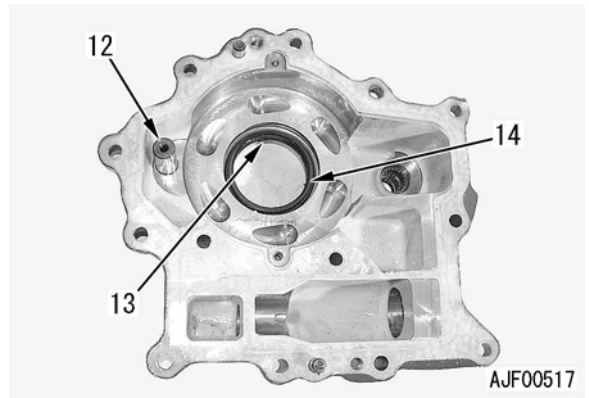

5. Lever

- 1) Remove the mounting bolt and lever (10).

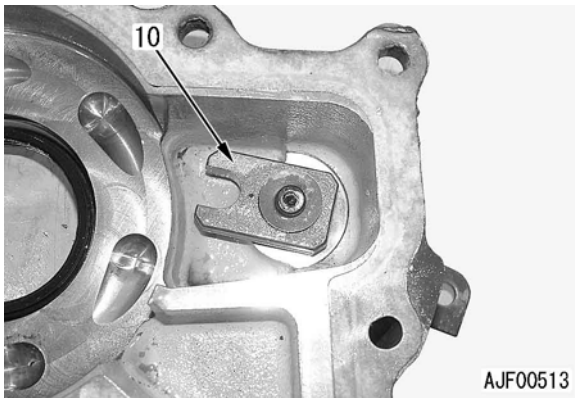

8. Oil seal and bearings

- 1) Remove oil seal (15).

- 2) Remove 2 bearings (16) from parking brake case (17).

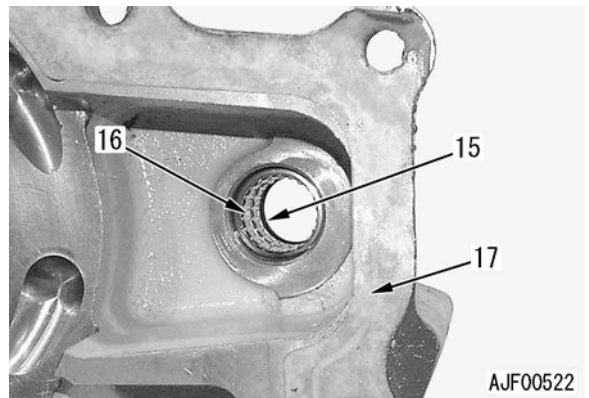

- 2) Remove lever (11).

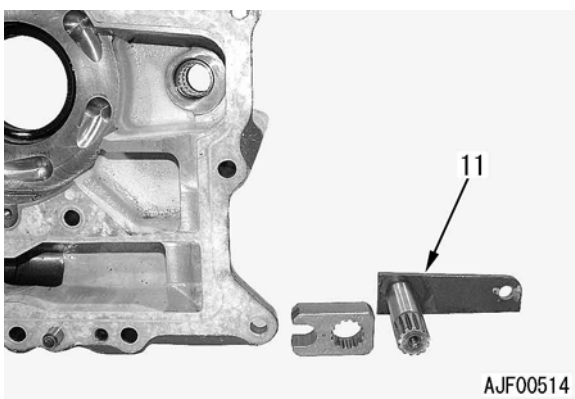

- 2) Set axle housing assembly (1) with the brake side up.

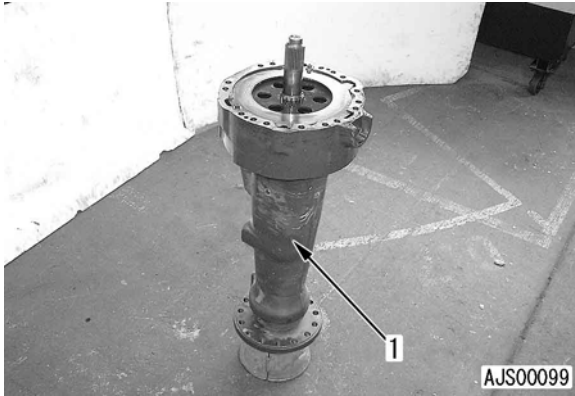

- 3) Remove end plate (38).
- 4) Remove sun gear shaft (39).

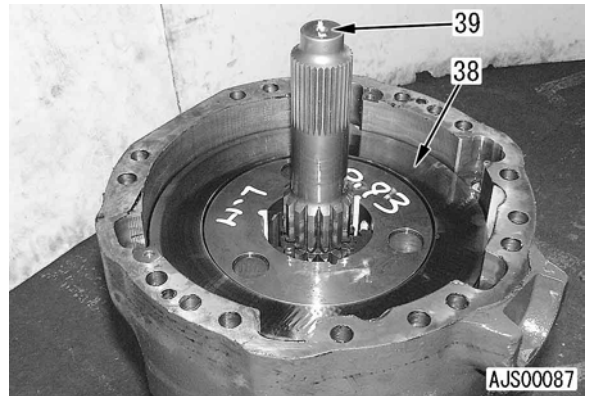

4. Brakes

★ Remove both brakes according to the following procedure.

- 1) Remove 2 inside hexagon bolts (34).

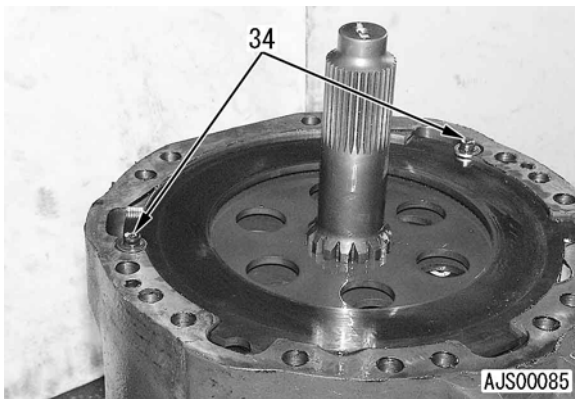

5. Planetary carrier assembly

- 1) Remove axle shaft mounting bolt (2).

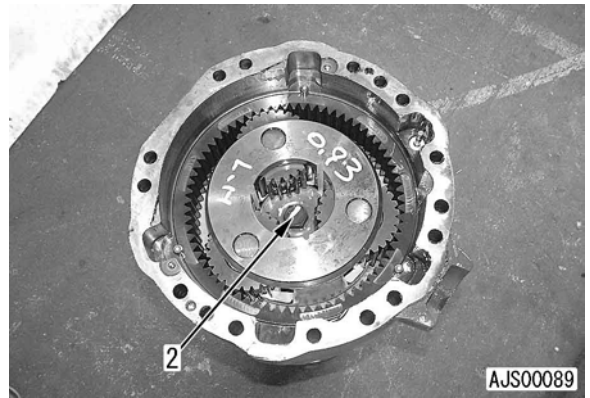

- 2) Remove 2 plates (35), 2 discs (36), and 2 wave springs (37).

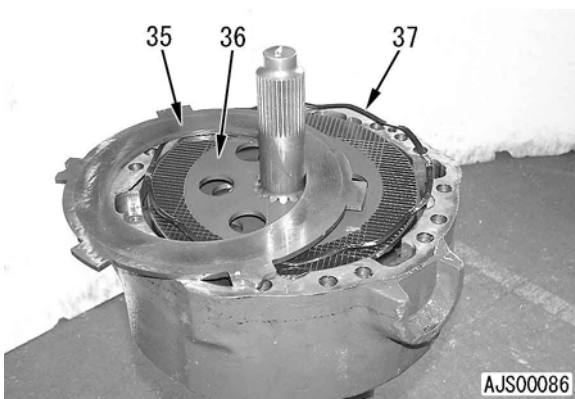

- 2) Remove planetary carrier assembly (3).

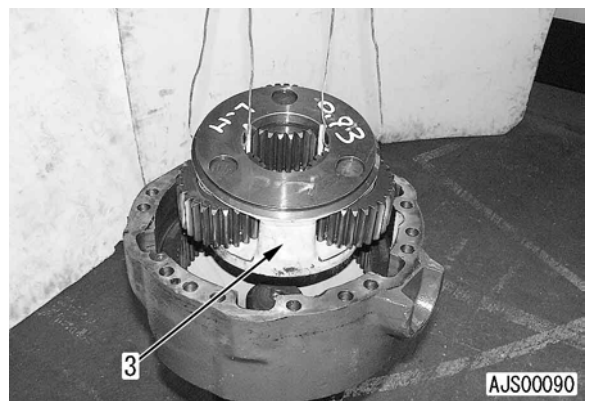

- 4) Install 2 inside hexagon bolts (34).

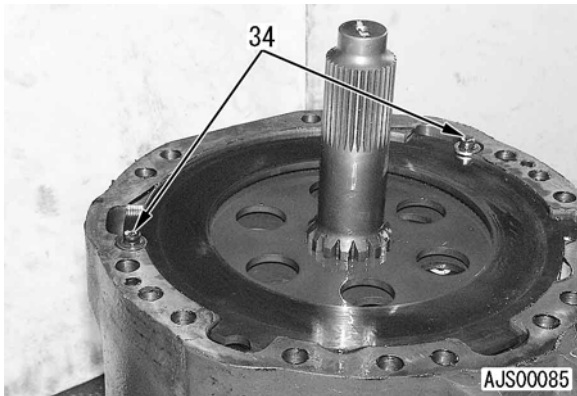

9. Rear axle support

- 1) Fit packing (53) to retainer (51) and install bushing (52), thrust washer (50), and retainer (51) to rear axle support (30).
 - ★ Clean and dry the inside of the support to insert the bushing.
 - ★ Press fit the bushing with a press having a surface plate and keep the support and bushing in parallel.
 - ★ Secure clearance of 0.5 between the end of the bushing and the bottom of the mounting part.
 - ★ Set thrust washer (50) with the groove up (Direct the groove toward the retainer).
 - ★ Direct the lip of the packing toward the outside of the rear axle support (toward the axle).

8. Axle housing assembly

- 1) Degrease and clean the mating faces of the axle housing and differential housing and apply gasket sealant all over them.

 Mating faces of housings: **Gasket sealant (LOCTITE 515 or equivalent)**

- 2) Sling axle housing assembly (1) horizontally and install it carefully, matching it to the spline grooves of the sun gear shaft.
 - ★ Set a jack under axle housing assembly (1) to prevent the axle housing assembly from falling down.

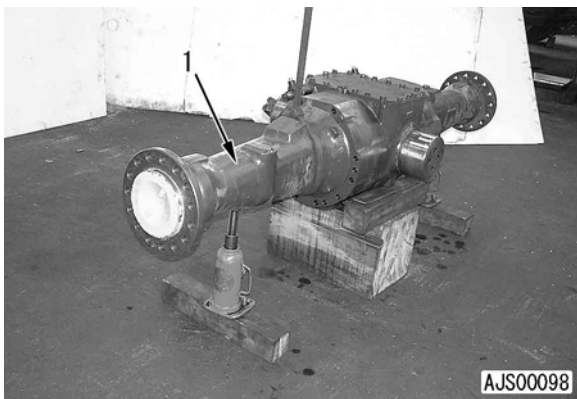

 Inside of packing: **Grease (G2-LI)**
(Apply thinly)

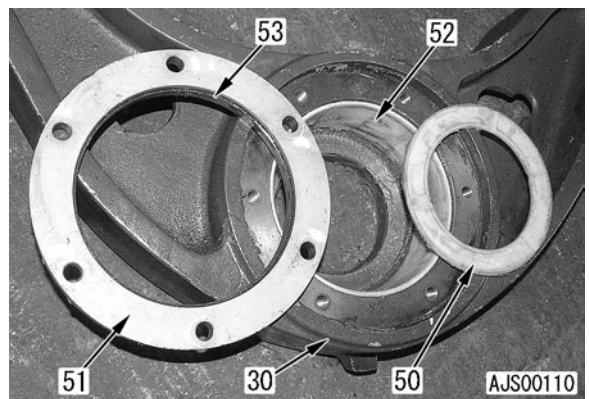

- 2) Sling and install rear axle support (30) and install thrust plate (32).

 Periphery of pivot mounting part: **Grease (G2-LI)**

 Mounting bolt: **490 - 608 Nm {50 - 62 kgm}**

- 3) Tighten the axle housing mounting bolts in the diagonal order.

 Mounting bolt: **245 - 309 Nm {25.0 - 31.5 kgm}**

11) Remove pressure ring (75).

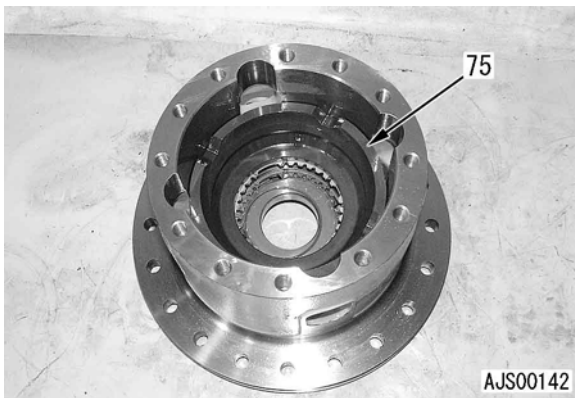

★ Removed parts

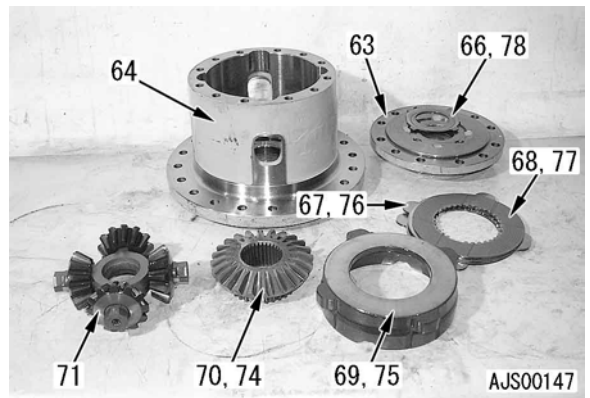

12) Remove 2 plates (76) and 2 discs (77).

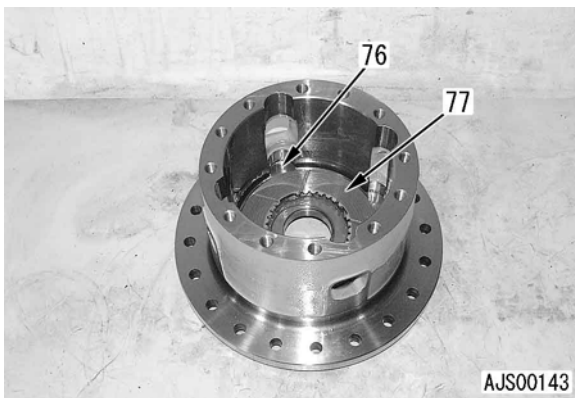

14) Using push tool [11], remove outer race (79) from inside of case (64). Similarly, using push tool [11], remove the outer race from inside of cover (63).

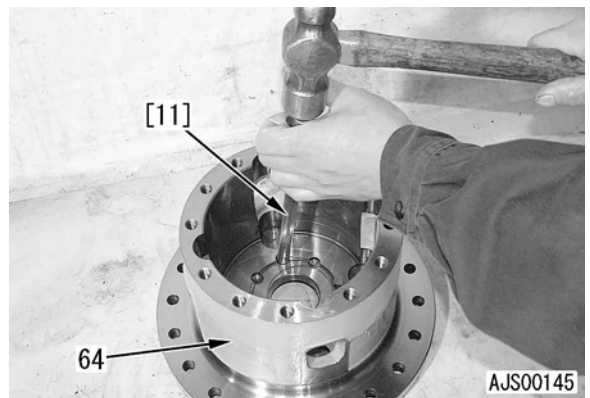

13) Remove washer (78).

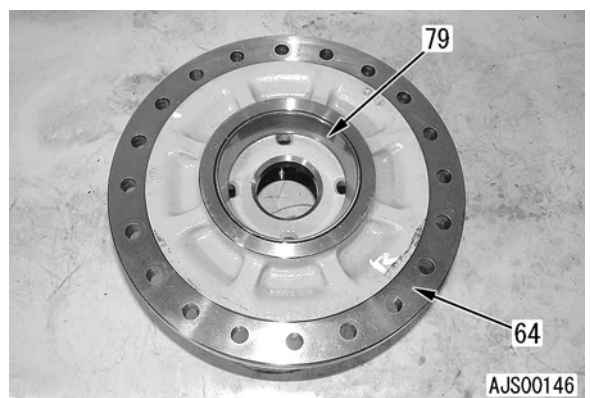
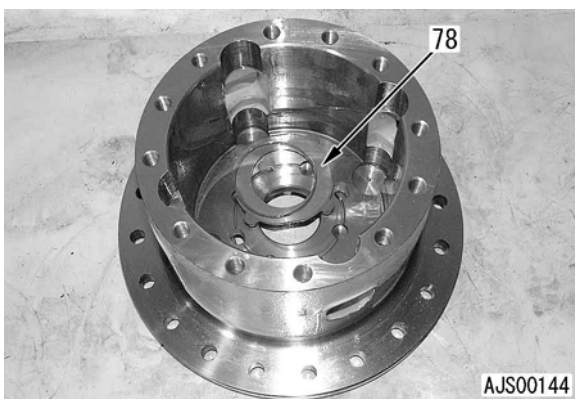

8. Installation of rear cage assembly (For rear differential)
- 1) Install guide bolt [19] to the differential case assembly, and then install shim (90), O-ring, and rear cage assembly (42).
 - ★ For the adjustment of the shims and tightening torque, see 7 INSTALLATION OF FRONT CAGE ASSEMBLY.

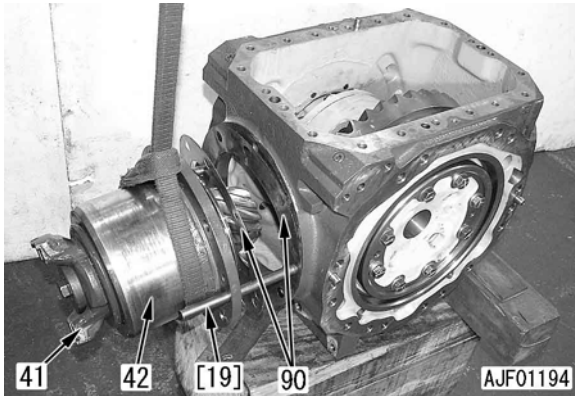

9. Adjusting backlash
- 1) Measure the backlash of the bevel gear with dial gauge [20].
 - Standard backlash: **0.20 - 0.33 mm**
 - ★ Measure the backlash at 3 places on the periphery of the bevel gear and check that the dispersion of the measured values is 0.1 mm or less.

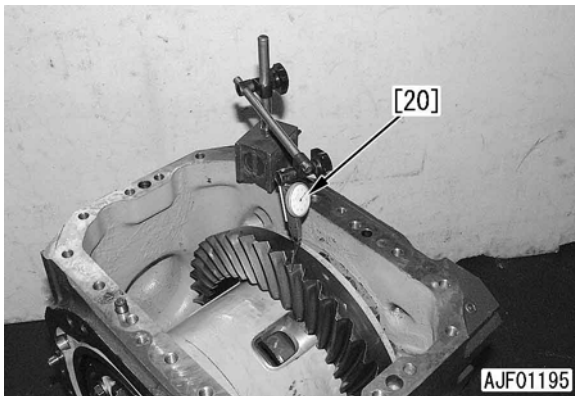

- 2) If the measured backlash is out of the standard range, adjust it by moving a part of the shims on either side to the opposite side.
 - ★ Do not change the total thickness of the shims on both sides.
 - ★ If the backlash is insufficient, move a part of shims (g) to the shims (f). (Move the bevel gear in direction A, or to the right in the figure.)
 - ★ If the backlash is too large, move a part of shims (f) to the shims (g). (Move the bevel gear in direction B, or to the left in the figure.)

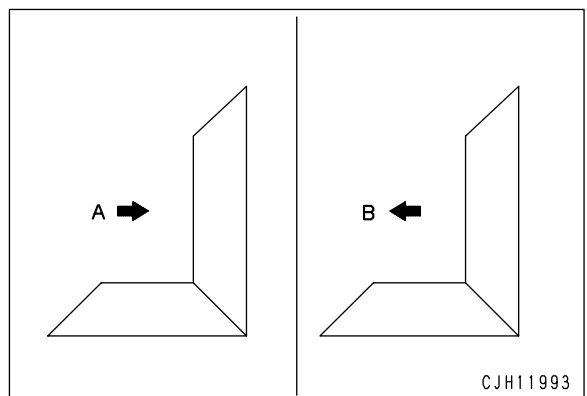
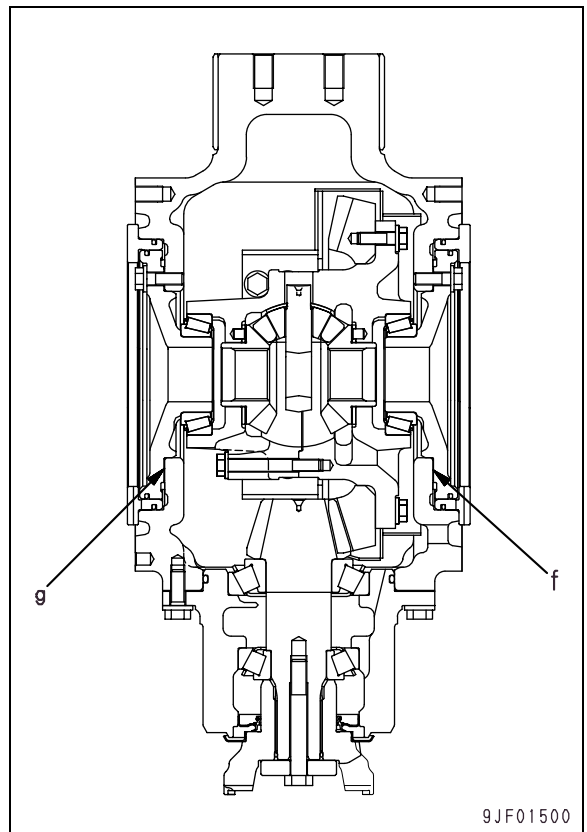

INSTALLATION

- Carry out installation in the reverse order to removal.

[*1]

 Motor 1 assembly mounting bolt:
245 - 309 Nm {25.0 - 31.5 kgm}

- **Refilling with oil (Hydraulic tank)**
Add oil through the oil filler to the specified level.
Run the engine to circulate the oil through the system. Then, check the oil level again.

 Hydraulic tank: **89 ℓ**

5. Set supports [2] under the end of the lift arm and release the residual pressure in the hydraulic piping.

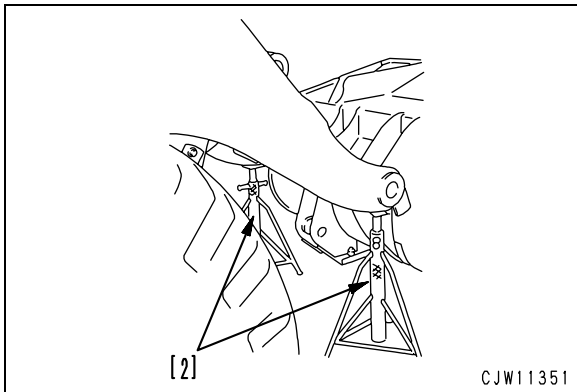

7. Disconnect boom positioner proximity switch connector F04 (7).
8. Remove boom kick-out switch (8). [*5]

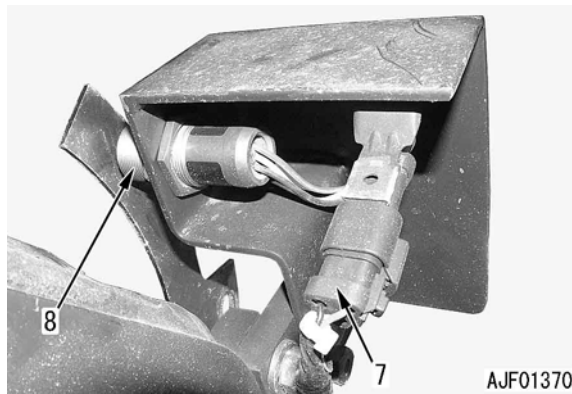

6. Sling lift cylinder assembly (6) temporarily and remove mounting pin (5). [*4]
 - ★ Check the thickness and quantity of the shims.
 - ★ When lowering the lift cylinder assembly, put a block on the axle.



Lift cylinder assembly (1 pieces):
110 kg

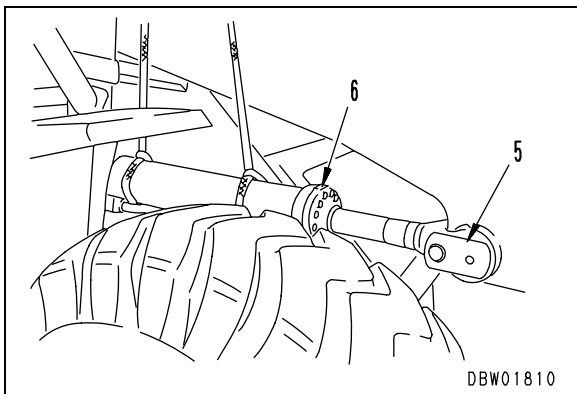

9. Sling lift arm and tilt lever and bucket link assembly (10) temporarily and pull out mounting pin (11). [*6]
 - ★ Check the thickness and quantity of the shims.

10. Lift off lift arm and tilt lever and bucket link assembly (10).



Lift arm and tilt lever and bucket link assembly: **1250 kg**

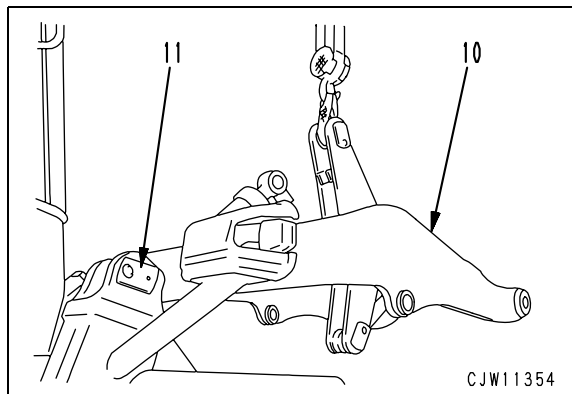

5. Cylinder block, Piston assembly

- 1) Assemble the cylinder block and piston assembly according to the following procedure.

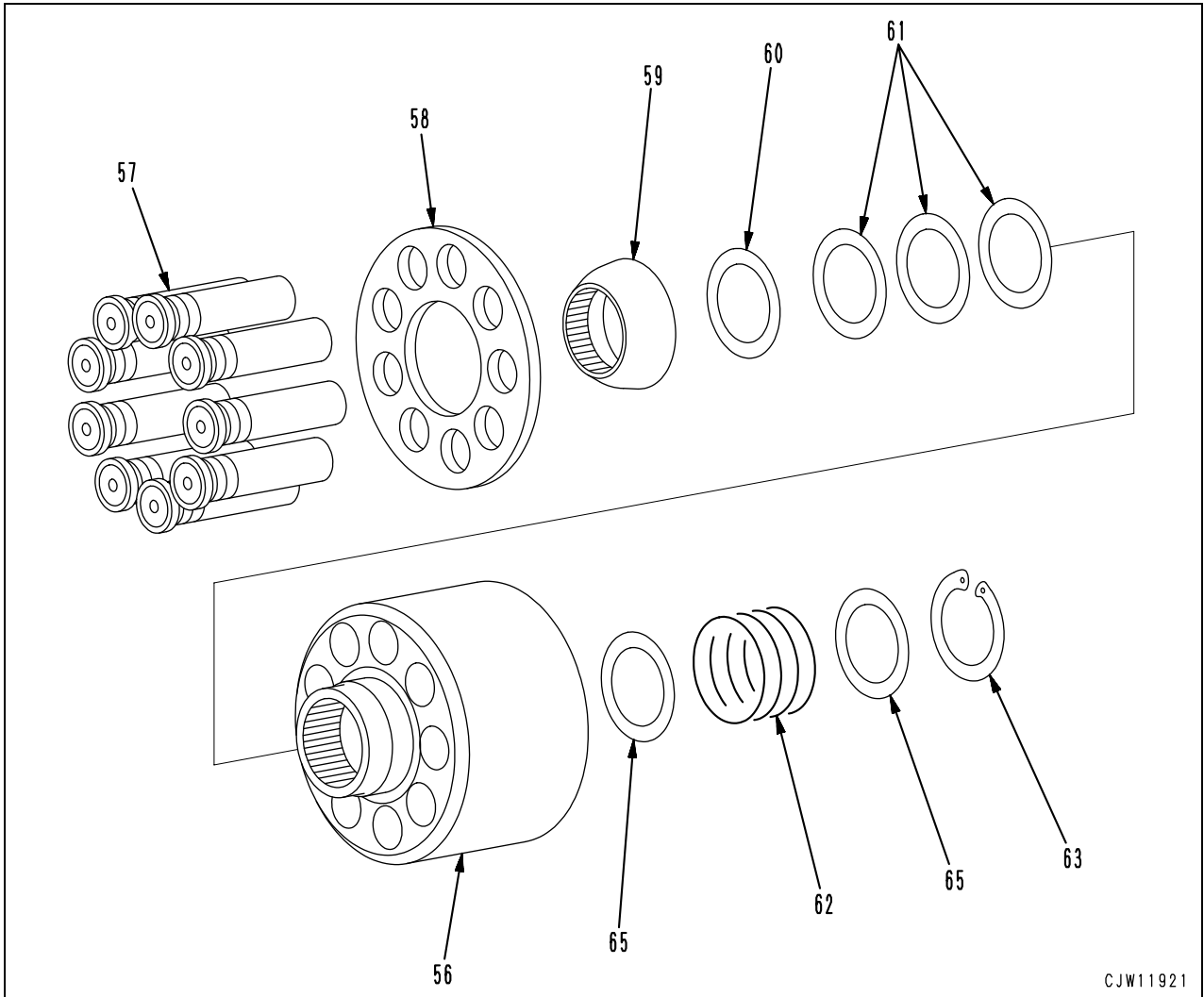

CJW11921

- ii) Plugs with internal hexagon, O-ring and UNF-, UN- threads to SAE J 514

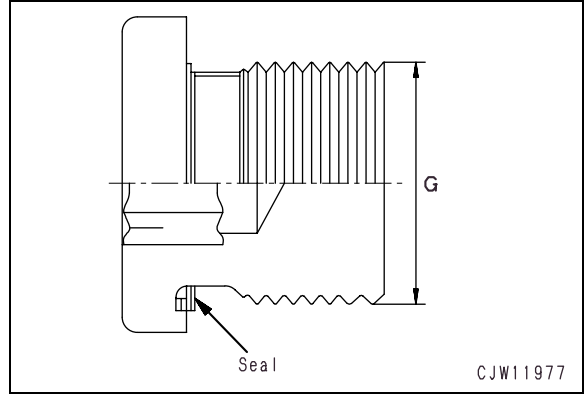

Thead	Tightening torque		Thead	Tightening torque	
	Nm	kgm		Nm	kgm
7/16-20UNF	15	1.53	M12 x 1.5	20	2.04
1/2-20UNF	20	2.04	M14 x 1.5	30	3.06
9/16-18UNF	25	2.55	M27 x 1.5	90	9.18
3/4-16UNF	72	7.34			
7/8-14UN	127	12.95			
11/16-12UN	147	14.99			
13/16-12UN	173	17.64			
15/16-12UN	198	20.19			
15/8-12UN	320	32.63			
17/8-12UN	390	39.77			

- 4) Push the shaft end with a press to remove shaft and rotary group assembly (81) from housing (82).

 If the bearings are used again do not hit on the drive shaft.

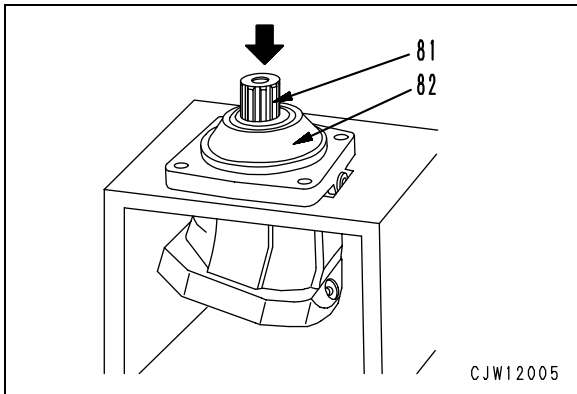

- ★ If a press is not available, push the shaft end with tool [3] or [4] to remove rotary group assembly (81).

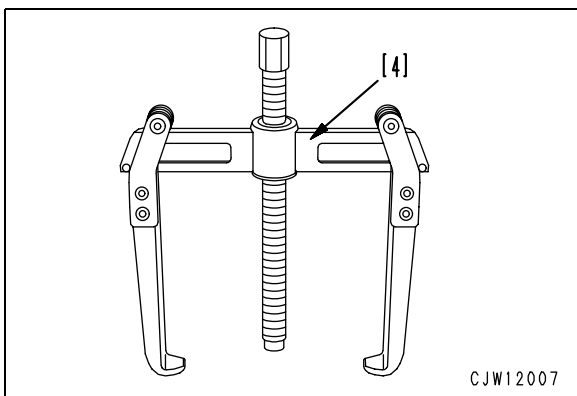
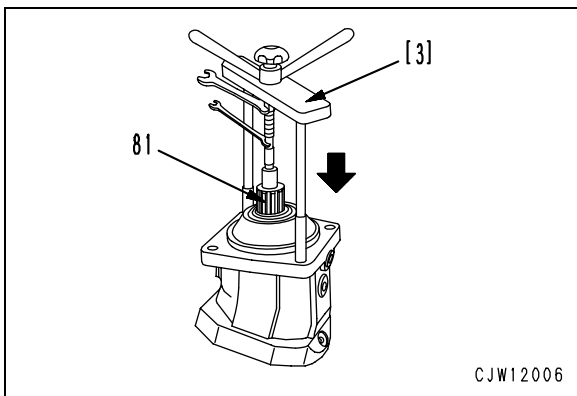

- ★ Check of housing
 - Sliding surface and slide guides free of scoring and no wear.

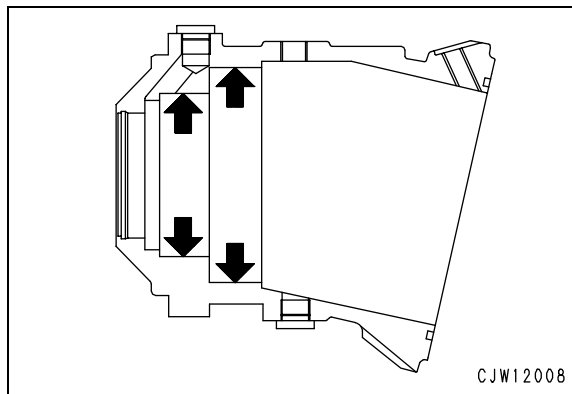

- ★ Since shaft and bearing are used as an assembly, do not remove the bearing.

- 7. Disassembly of rotary group assembly (70)
 - 1) Remove screw [2].
 - 2) Remove cylinder block (83).

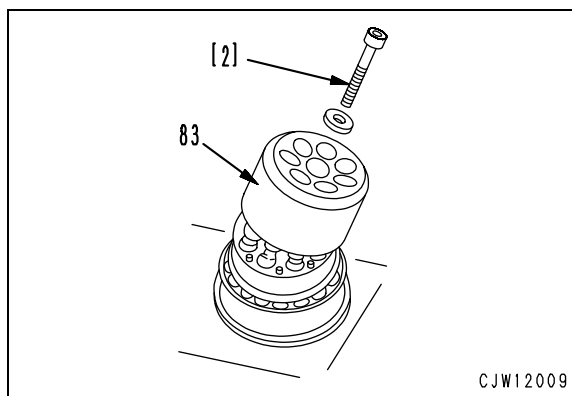

- 3) Remove shim (84) from cylinder block (83).

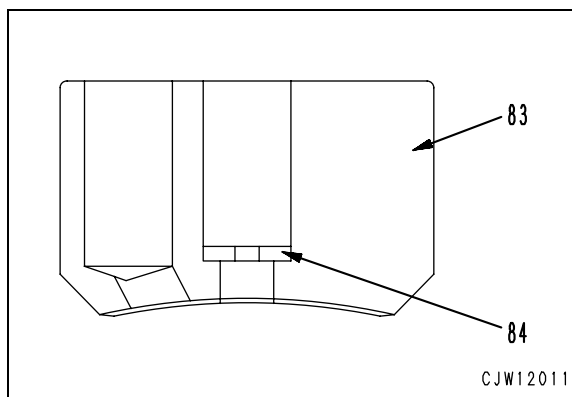

3. Cylinder head and piston rod assembly (Bucket cylinder and boom cylinder)
 - 1) Remove the mounting bolt of cylinder head assembly (2).
 - Width across flats of bolt: **24 mm**

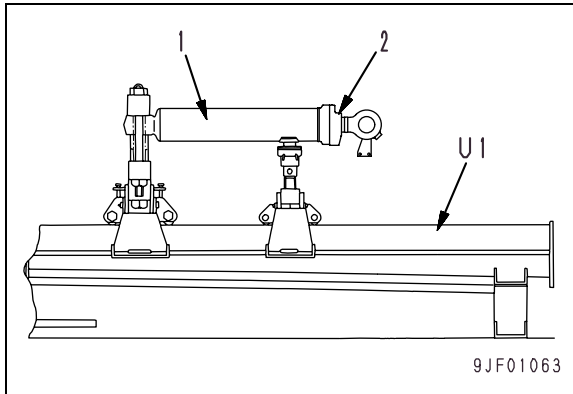

- 2) Pull cylinder head and piston rod assembly (3) out of cylinder (4).
 - ★ Since oil will flow out when the piston rod assembly is pulled out of the cylinder, prepare an oil receiver.

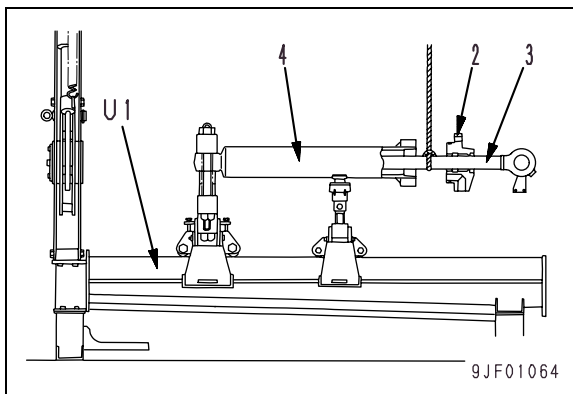

4. Piston and cylinder head (Steering cylinder)
 - 1) Set cylinder head and piston rod assembly (3) to tool U1.
 - 2) Using tool U3, remove nut (5).
 - Width across flats of nut (Steering): **46 mm**
 - 3) Remove piston assembly (6) and cylinder head assembly (2).

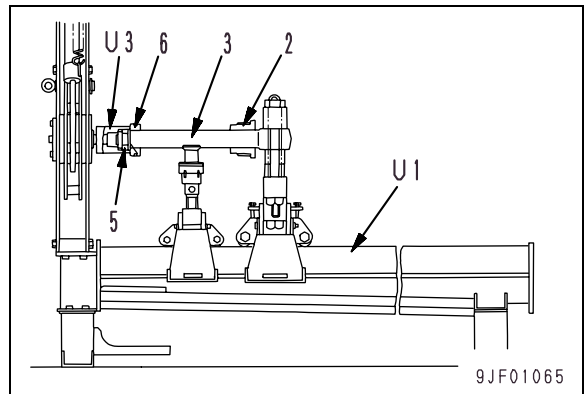

21. Remove 4 operator's cab mounting nuts (41).[*4]



22. Lift off operator's cab assembly (42).

- ★ Check that all the wires and pipes are disconnected.



Operator's cab: **810 kg**



INSTALLATION

- Carry out installation in the reverse order to removal.

[*1]

- ★ Adjust the fuel control cable. For details, see TESTING AND ADJUSTING, Testing and adjusting fuel accelerator pedal assembly.



Mounting nut of ball joint:

11.8 - 14.7 Nm {1.2 - 1.5 kgm}



Locknut: **44 - 59 Nm {4.5 - 6.0 kgm}**

[*2]

- ★ Adjust the brake linkage. For details, see TESTING AND ADJUSTING, Testing and adjusting brake pedal linkage.

[*3]

- ★ Orbit-roll valve hoses



Port LS: **14.7 - 24.5 Nm {1.5 - 2.5 kgm}**



Ports P, R, T, and L:

53.9 - 73.5 Nm {5.5 - 7.5 kgm}

[*4]



Operator's cab mounting nut:

824 - 1030 Nm {84 - 105 kgm}

[*5]

- ★ After inserting cotter pin (52) in pin (53), open it to 180 degrees.

[*6]



Parking brake wire locknut:



34.3 - 58.8 Nm {3.5 - 6.0 kgm}

REMOVAL, INSTALLATION OF CENTER HINGE PIN

SPECIAL TOOLS

Symbol	Part No.	Part Name	Necessity	Qty	New/Remodel	Sketch
Y	1	790-101-5201	Push tool kit	■	1	
		• 790-101-5281	• Plate		1	
		• 790-101-5221	• Grip		1	
		• 01010-51225	• Bolt		1	
	2	793-840-1410	Push tool kit	■	1	
3	793-840-1420	Push tool kit	■	1		
4	793-415-1180	Push tool kit	■	1		

REMOVAL

-  Stop the vehicle on a level place and set the safety bar to the frame.
-  Lower the work equipment to the ground, stop the engine, apply the parking brake, and put chocks under the tires.
-  Disconnect the cable from the negative (-) terminal of the battery.

1. Raise the front part of the chassis with the work equipment and set blocks [1] under the frame at the rear of the front wheel to float the front part of the chassis.



2. Set the work horizontally, place blocks [1] under both sides of the rear frame, raise the counterweight with hydraulic jack [2], and set stands [3].

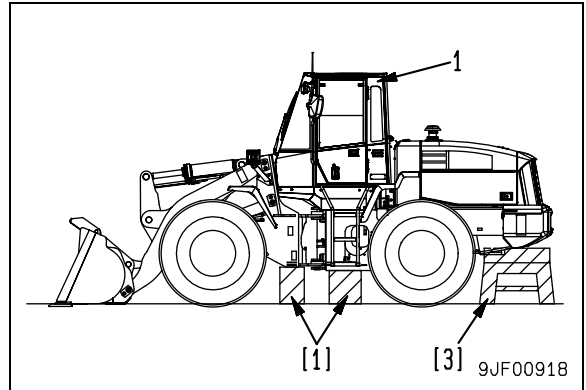

3. Remove operator's cab assembly (1). For details, see Removal of operator's cab assembly.
4. Remove work equipment valve top cover (2).



8. Insert selected shim (17) between cover (15) and the rear frame and tighten the 6 mounting bolts.

 Mounting bolt:
Adhesive (LOCTITE #2701)

 Mounting bolt:
98 - 123 Nm {10.0 - 12.5 kgm}

9. Install lock bolt (12) of lower hinge pin (13).

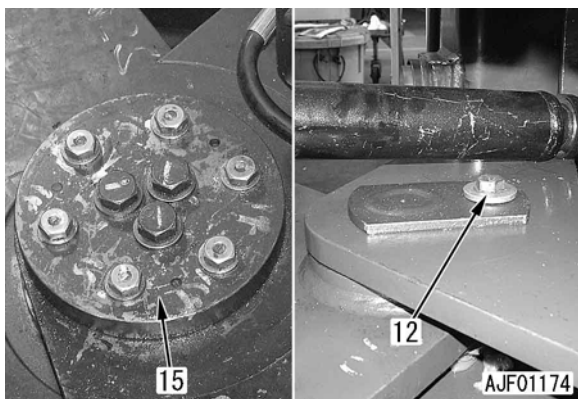

★ A clearance of 1 mm should be made at (b) between bushing (35) and lower hinge pin (13).

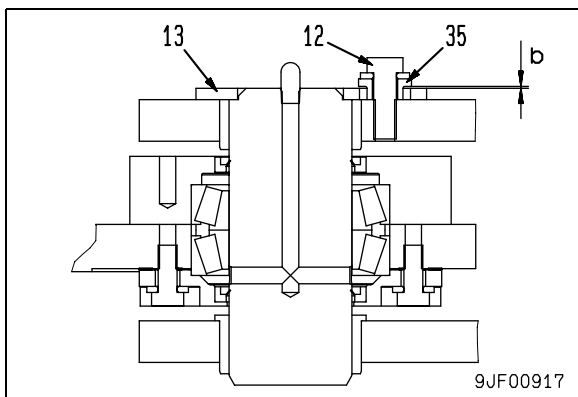

10. Install mounting bolt (14) of upper hinge pin (16).

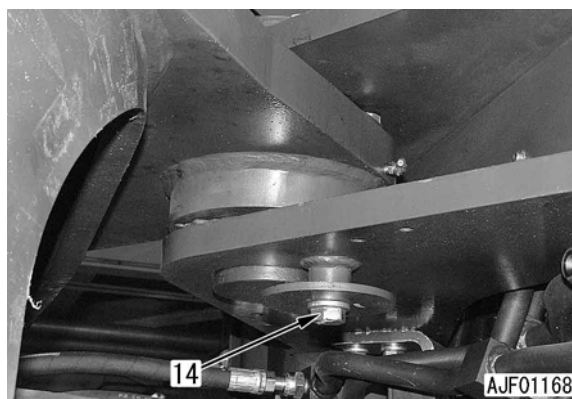

- **Refilling with oil (Hydraulic tank)**
Add oil through the oil filler to the specified level. Run the engine to circulate the oil through the system. Then, check the oil level again.

10. Remove monitor panel (23) from bracket (24).
[*5]

- ★ The standard monitor panel is shown in the photo. The monitor panel with service meter specification is similar to the standard one.

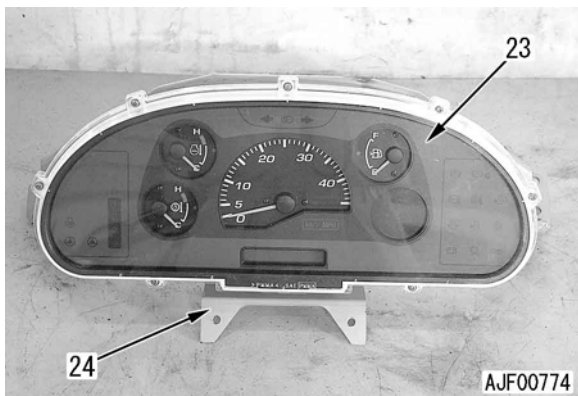

- ★ Correspondence table of wiring connectors (Load meter specification)
 - (31): L24
 - (32): L30
 - (33): L29
 - (34): L25
 - (35): L26
 - (36): L27
 - (37): L28
 - (38): No connectors correspond.

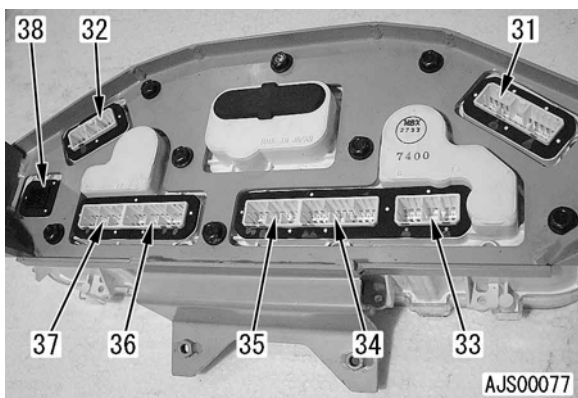

INSTALLATION

- Carry out installation in the reverse order to removal.

[*1]

 Steering wheel mounting nut:
29 ± 2.9 Nm {3.0 ± 0.3 kgm}

[*2]

 Cover mounting bolt (Fine thread):
1.97 - 2.45 Nm {0.2 - 0.25 kgm}

 Cover mounting bolt (Coarse thread):
5.88 Nm {0.6 kgm}

[*3]

- ★ Decide the height by matching hole (26) at the height reference mark to projection (27).

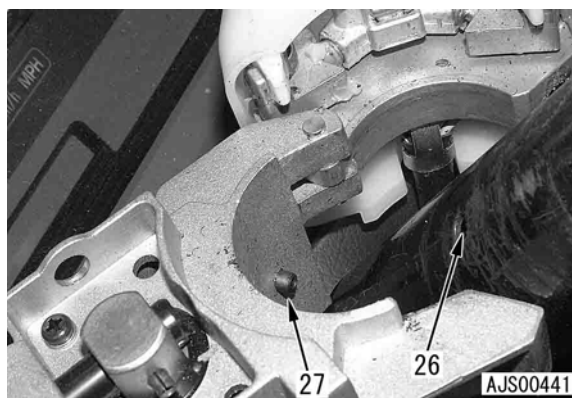

 Crossed screw:
4.9 - 7.84 Nm {0.5 - 0.8 kgm}

[*4]

 Front panel cover mounting bolt:
3.44 - 4.4 Nm {0.35 - 0.45 kgm}

[*5]

 Monitor panel mounting bolt:
2.75 - 3.53 Nm {0.28 - 0.30 kgm}

CLICK HERE TO **DOWNLOAD** THE COMPLETE MANUAL

- Thank you very much for reading the preview of the manual.
- You can download the complete manual from: www.heydownloads.com by clicking the link below



- Please note: If there is no response to CLICKING the link, please download this PDF first and then click on it.

CLICK HERE TO **DOWNLOAD** THE COMPLETE MANUAL