

SHOP

MANUAL

WA250-6

WA250PZ-6

MACHINE MODEL

SERIAL NUMBER

WA250-6

75001 and up

WA250PZ-6

**75160 and up
H00051 and up**

- This shop manual may contain attachments and optional equipment that are not available in your area. Please consult your local Komatsu distributor for those items you may require. Materials and specifications are subject to change without notice.
- WA250-6 and WA250PZ-6 mounts the SAA6D107E-1 engine.

CLICK HERE TO **DOWNLOAD** THE COMPLETE MANUAL

- Thank you very much for reading the preview of the manual.
- You can download the complete manual from: www.heydownloads.com by clicking the link below



- Please note: If there is no response to CLICKING the link, please download this PDF first and then click on it.

CLICK HERE TO **DOWNLOAD** THE COMPLETE MANUAL

50 Disassembly and assembly	
100 General information on disassembly and assembly	SEN03851-00
How to read this manual	2
Coating materials list	4
Special tool list	7
Sketches of special tools	11
200 Engine and cooling system	SEN03852-00
Removal and installation of fuel supply pump assembly	2
Removal and installation of fuel injector assembly	4
Removal and installation of cylinder head assembly	11
Removal and installation of engine hood assembly	24
Removal and installation of radiator	27
Removal and installation of air aftercooler	30
Removal and installation of hydraulic oil cooler assembly	32
Removal and installation of engine assembly	34
Removal and installation of engine front oil seal assembly	40
Removal and installation of engine rear oil seal assembly	43
Removal and installation of cooling fan and fan motor assembly	46
Removal and installation of fuel tank assembly	49
310 Power train, Part 1	SEN03853-00
Removal and installation of transfer assembly	2
Disassembly and assembly of transfer assembly	6
Removal and installation of parking brake assembly	26
Disassembly and assembly of parking brake assembly	28
320 Power train, Part 2	SEN03854-00
Removal and installation of front axle assembly	2
Removal and installation of rear axle assembly	4
Disassembly and assembly of axle housing assembly	7
Disassembly and assembly of differential assembly	16
400 Undercarriage and frame	SEN03855-00
Removal and installation of center hinge pin	2
Removal and installation of counterweight	12
500 Hydraulic system	SEN03856-00
Removal and installation of HST pump and 4-gear pump assembly	2
Disassembly and assembly of HST pump assembly	6
Removal and installation of HST motor 1 assembly	33
Removal and installation of HST motor 2 assembly	35
Disassembly and assembly of HST motor assembly	37
Removal and installation of work equipment control valve assembly	53
Removal and installation of hydraulic tank	55
Disassembly and assembly of hydraulic cylinder assembly	57
600 Work equipment	SEN03857-01
Removal and installation of work equipment assembly	2
700 Cab and its attachments	SEN03858-00
Removal and installation of operator's cab and floor frame assembly	2
Removal and installation of operator's cab glass (Stuck glass)	7
Removal and installation of air conditioner unit	15
800 Electrical system	SEN03859-00
Removal and installation of monitor panel	2
Removal and installation of engine controller assembly	4
Removal and installation of HST controller assembly	5
Removal and installation of KOMTRAX terminal assembly	6

Handling of electric equipment and hydraulic component

To maintain the performance of the machine over a long period, and to prevent failures or other troubles before they occur, correct “operation”, “maintenance and inspection”, “troubleshooting”, and “repairs” must be carried out. This section deals particularly with correct repair procedures for mechatronics and is aimed at improving the quality of repairs. For this purpose, it gives sections on “Handling electric equipment” and “Handling hydraulic equipment” (particularly gear oil and hydraulic oil).

Points to remember when handling electric equipment

1. Handling wiring harnesses and connectors

Wiring harnesses consist of wiring connecting one component to another component, connectors used for connecting and disconnecting one wire from another wire, and protectors or tubes used for protecting the wiring.

Compared with other electrical components fitted in boxes or cases, wiring harnesses are more likely to be affected by the direct effects of rain, water, heat, or vibration. Furthermore, during inspection and repair operations, they are frequently removed and installed again, so they are likely to suffer deformation or damage. For this reason, it is necessary to be extremely careful when handling wiring harnesses.

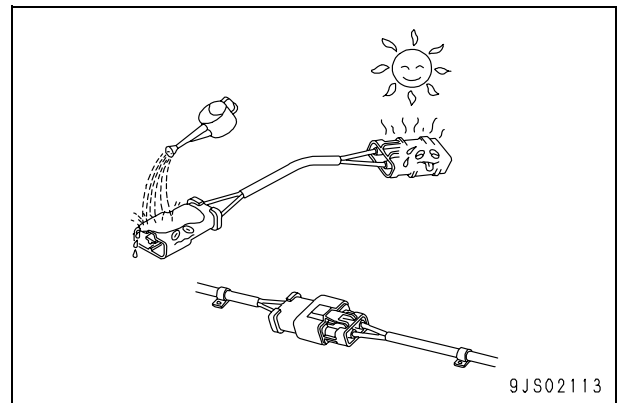

2. Main failures occurring in wiring harness

1) Defective contact of connectors (defective contact between male and female)

Problems with defective contact are likely to occur because the male connector is not properly inserted into the female connector, or because one or both of the connectors is deformed or the position is not correctly aligned, or because there is corrosion or oxidization of the contact surfaces. The corroded or oxidized contact surfaces may become shiny again (and contact may become normal) by connecting and disconnecting the connector about 10 times.

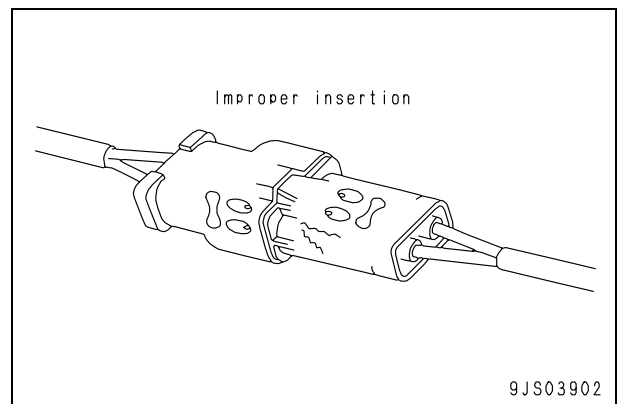

2) Defective crimping or soldering of connectors

The pins of the male and female connectors are in contact at the crimped terminal or soldered portion, but if there is excessive force brought to bear on the wiring, the plating at the joint will peel and cause improper connection or breakage.

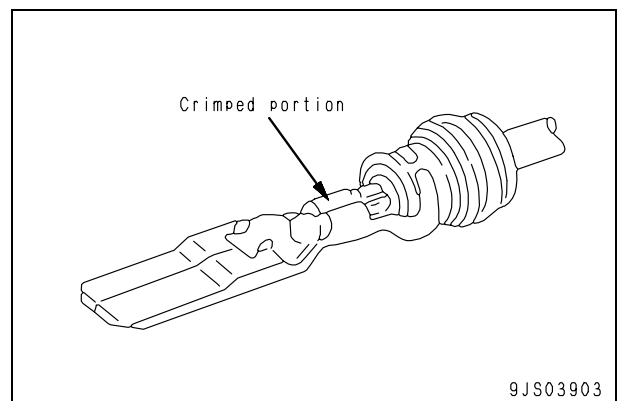

How to read electric wire code

- ★ The information about the wires unique to each machine model is described in Troubleshooting section, Relational information of troubleshooting.

In the electric circuit diagram, the material, thickness, and color of each electric wire are indicated by symbols. The electric wire code is helpful in understanding the electric circuit diagram.

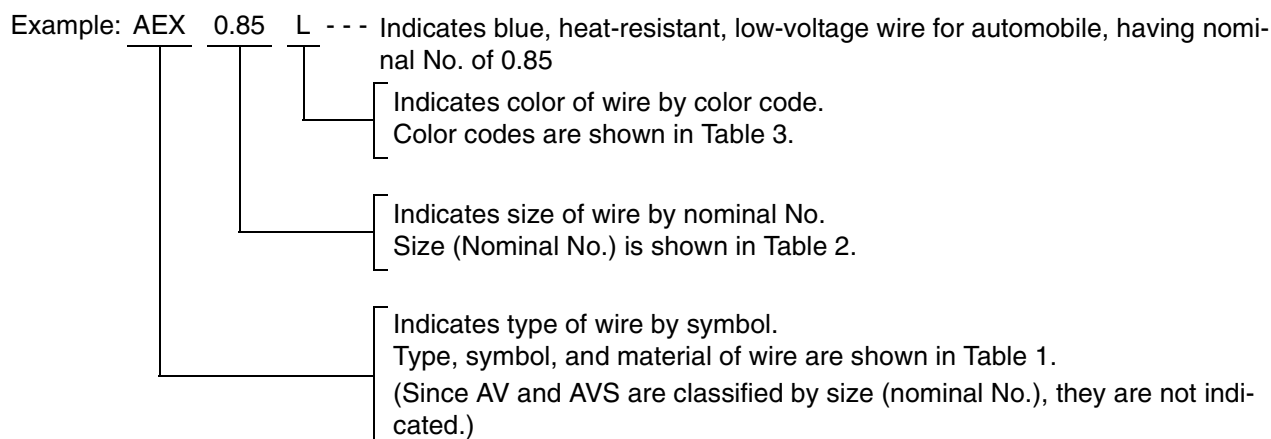

1. Type, symbol, and material

AV and AVS are different in only thickness and outside diameter of the cover. AEX is similar to AV in thickness and outside diameter of AEX and different from AV and AVS in material of the cover.

(Table 1)

Type	Sym- bol	Material		Using temperature range (°C)	Example of use
Low-voltage wire for automobile	AV	Conduc- tor	Annealed copper for elec- tric appliance	-30 to +60	General wiring (Nominal No. 5 and above)
		Insulator	Soft polyvinyl chloride		
Thin-cover low-voltage wire for automobile	AVS	Conduc- tor	Annealed copper for elec- tric appliance		
		Insulator	Soft polyvinyl chloride		General wiring (Nominal No. 3 and below)
Heat-resis- tant low-volt- age wire for automobile	AEX	Conduc- tor	Annealed copper for elec- tric appliance	-50 to +110	General wiring in extremely cold district, wiring at high-tem- perature place
		Insulator	Heat-resistant crosslinked polyethylene		

8. Table of tightening torques for 102, 107 and 114 engine series (Taper screws)

- ★ Unless there are special instructions, tighten the taper screws (unit: inch) of the 102, 107 and 114 engine series to the torque below.

Thread size inch	Tightening torque	
	Nm	kgm
1/16	3 ± 1	0.31 ± 0.10
1/8	8 ± 2	0.81 ± 0.20
1/4	12 ± 2	1.22 ± 0.20
3/8	15 ± 2	1.53 ± 0.20
1/2	24 ± 4	2.45 ± 0.41
3/4	36 ± 5	3.67 ± 0.51
1	60 ± 9	6.12 ± 0.92

Machine model name		WA250-6		WA250PZ-6		
Serial No.		75001 and up		75160 and up H00051 and up		
Hydraulic equipment	Cylinder Coupler plunger	Type		—	Double-acting piston type	
		Cylinder bore	mm	—	35	
		Piston rod outside diameter	mm	—	20	
		Stroke	mm	—	214	
		Max. distance between centers of pins	mm	—	586	
		Min. distance between centers of pins	mm	—	372	
	Control valve	Work equipment control valve			2-spool type	
		• Type • Set pressure	MPa{kg/cm ² }		20.6 {210}	
	Steering valve	Steering valve			Orbit-roll type	
		• Type • Set pressure	MPa{kg/cm ² }		18.6 {190}	
Motor	Cooling fan motor			Fixed displacement, swash plate, piston type <with reversible valve and flow control valve>		
	• Type • Motor capacity	cm ³ /rev		11.5		
Work equipment	Type of link		Z-bar link	Parallel movement type Z-bar link		
	Shape of bucket cutting edge		Straight cutting edge with BOC	Straight cutting edge with BOC		

★ BOC: Abbreviation for Bolt-On Cutting edge

1. Output shaft
2. Case
3. Thrust plate
4. Shoe
5. Piston
6. Cylinder block
7. Valve plate
8. End cover
9. Bearing
10. Center spring
11. Retainer shoe
12. Retainer guide
13. Bearing
14. Oil seal
15. Flow control spool
16. Suction safety valve
17. Reversible spool

Unit: mm

No.	Item	Criteria					Remedy
		Standard size			Repair limit		
		Free length x Outside diameter	Installed length	Installed load	Free length	Installed load	
18	Spool return spring	44.84 x 12	33	58.8 N {6 kg}	—	47.1 N {4.8 kg}	If damaged or deformed, replace spring
19	Spool return spring	35 x 8.5	34	44.1 N {4.5 kg}	—	35.3 N {3.6 kg}	

HST hydraulic piping diagram

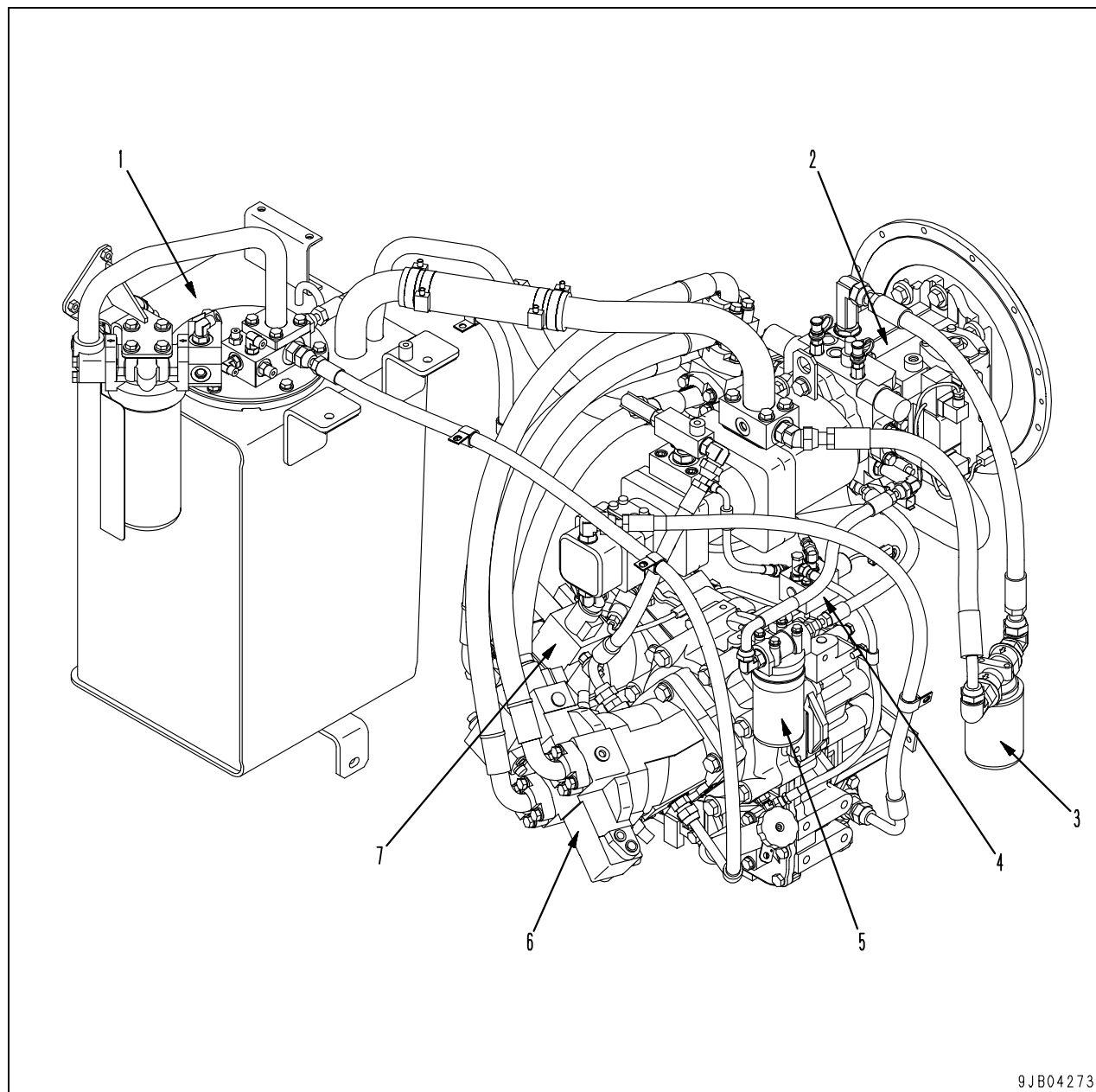

1. Hydraulic tank
2. HST pump
3. HST drain oil filter
4. Clutch solenoid valve
5. HST oil filter
6. HST motor 1
7. HST motor 2

EP servo valve

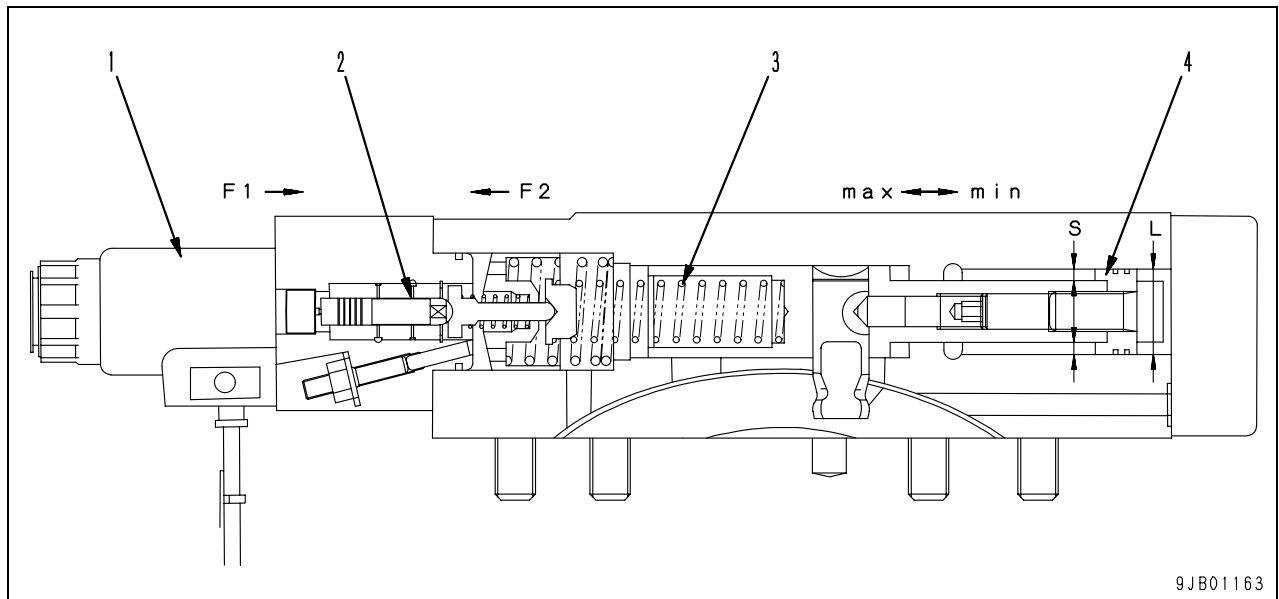

1. Motor 1 solenoid valve
2. EP servo valve
3. Spring
4. Servo cylinder

Function

- This valve is installed on the rear side of HST motor 1. It controls the motor displacement depending on the current value given to motor 1 solenoid valve (1).

Operation

- Suction force F_1 of motor 1 solenoid valve (1) and force F_2 of spring (3) are applied to EP servo valve (2).
- When the current value given to motor 1 solenoid valve (1) is small (when $F_1 < F_2$), EP servo valve (2) conducts the oil pressure on the motor high pressure side circuit to the small diameter side (S) of servo cylinder (4) and releases the oil pressure on the large diameter side (L) to the tank (motor housing). As the result, the servo cylinder (4) is moved toward the min side.
- When the current value given to motor 1 solenoid valve (1) is large (when $F_1 > F_2$), EP servo valve (2) conducts the oil pressure to the large diameter side (L) to move servo cylinder (4) toward the max side using the difference in area between the large diameter and small diameter side (S).
- Magnitude of spring (3) force varies depending on the position of servo cylinder (4) (motor displacement).
- The current value given to motor 1 solenoid valve (1) controls the motor displacement to the position where suction power F_1 and spring force F_2 balance.

Power transmitting route

Low speed mode

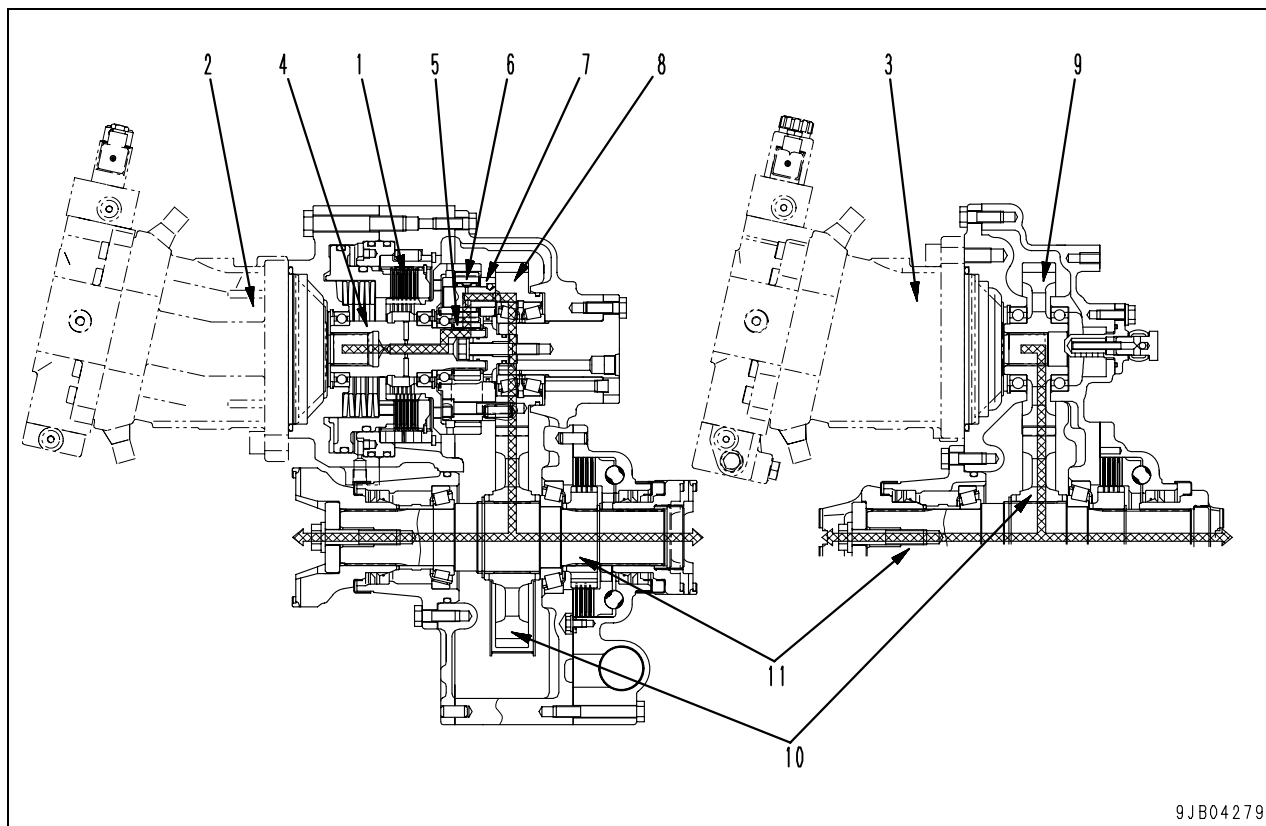

9JB04279

Transfer clutch (1) is fixed to transmit power of both HST motor 1 (2) and HST motor 2 (3).

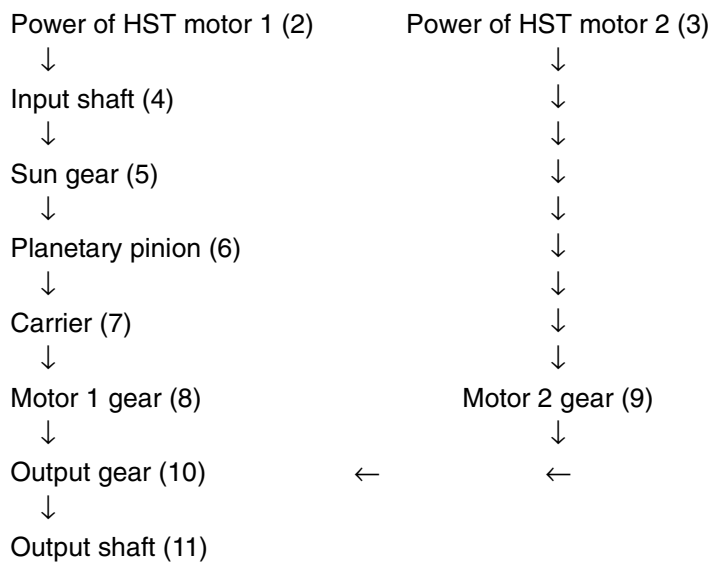

Blank for technical reason

Steering piping diagram

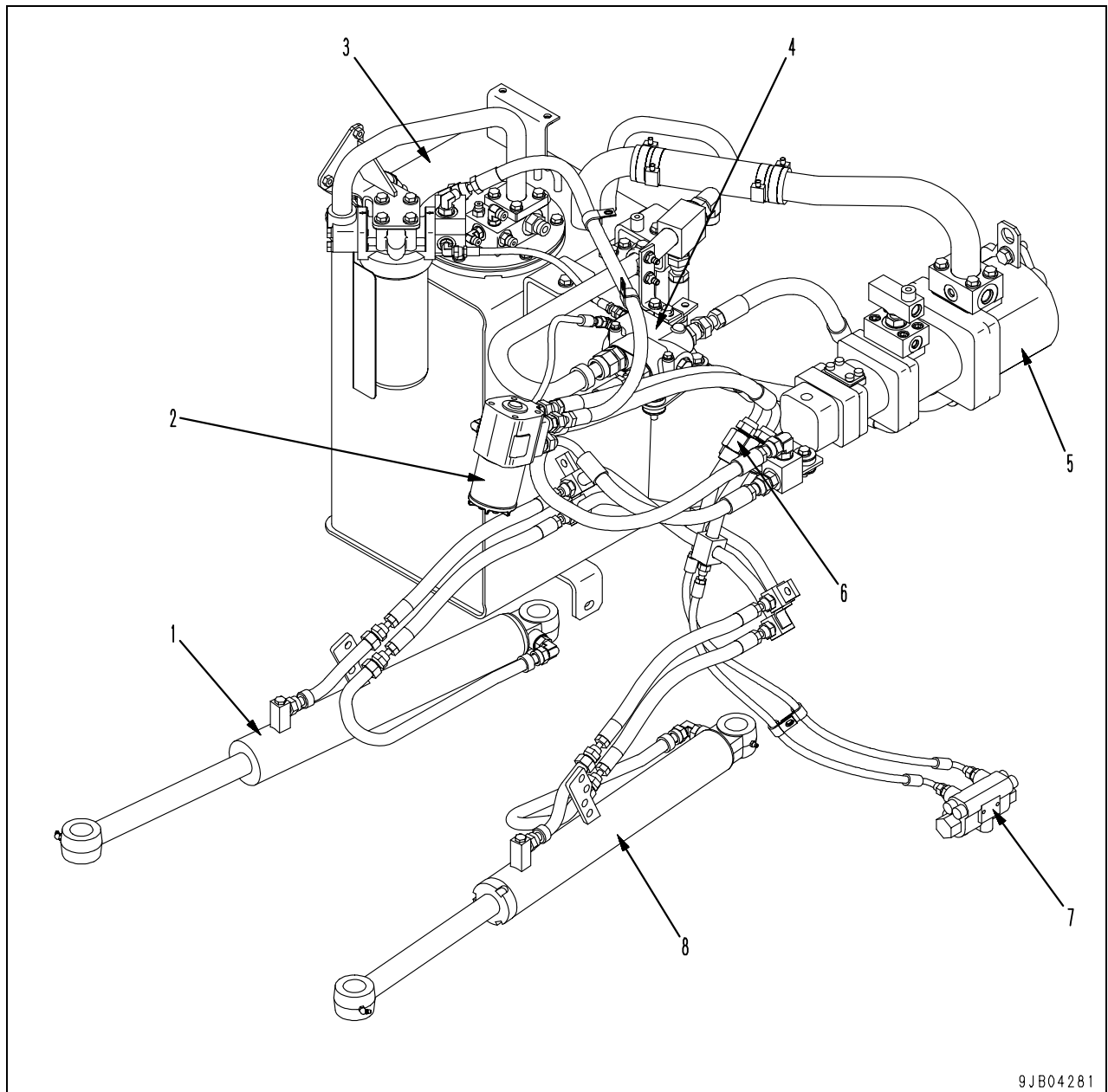

1. Steering cylinder (right)
2. Orbit-roll valve
3. Hydraulic tank
4. Priority valve
5. Steering pump
6. 2-way restrictor valve
7. Cushion valve
8. Steering cylinder (left)

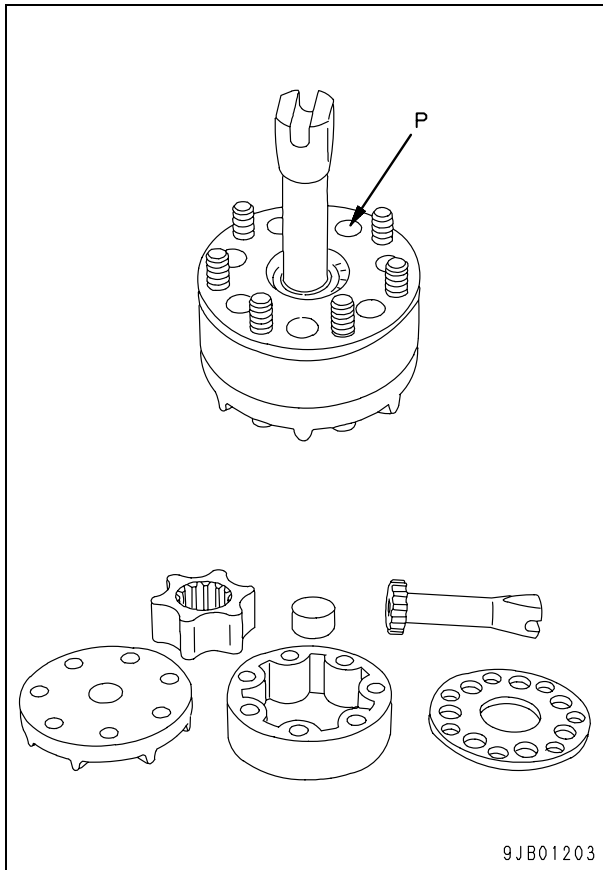

Role of centering spring

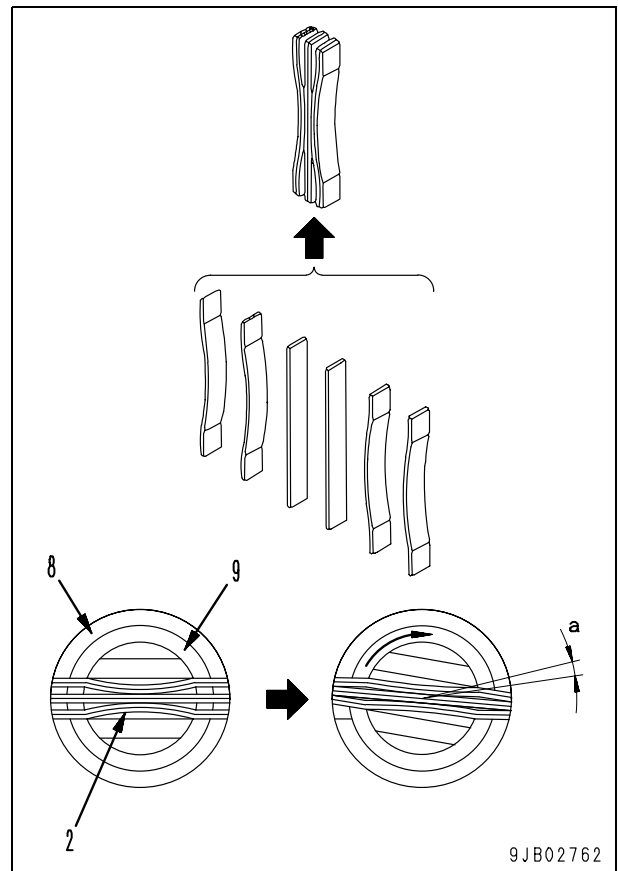

- Centering spring (2) is composed of 4 X-shaped leaf springs and 2 flat leaf springs and installed between spool (9) and sleeve (8) as shown in the figure.
- If the steering wheel is turned, spool (9) compresses centering spring (2) and angular displacement (a) is generated between spool (9) and sleeve (8).

As a result, the ports of spool (9) and sleeve (8) are connected and the oil is sent to the steering cylinder. When the steering wheel stops turning, the Gerotor also stops turning. Then, the oil is not sent to the steering cylinder any more and its pressure rises.

To prevent this, when the steering wheel stopped turning, Gerotor is turned by the reaction force of centering spring (2) by angular displacement (a) of spool (9) and sleeve (8) to return the steering wheel to the "neutral" position.

Brake piping diagram

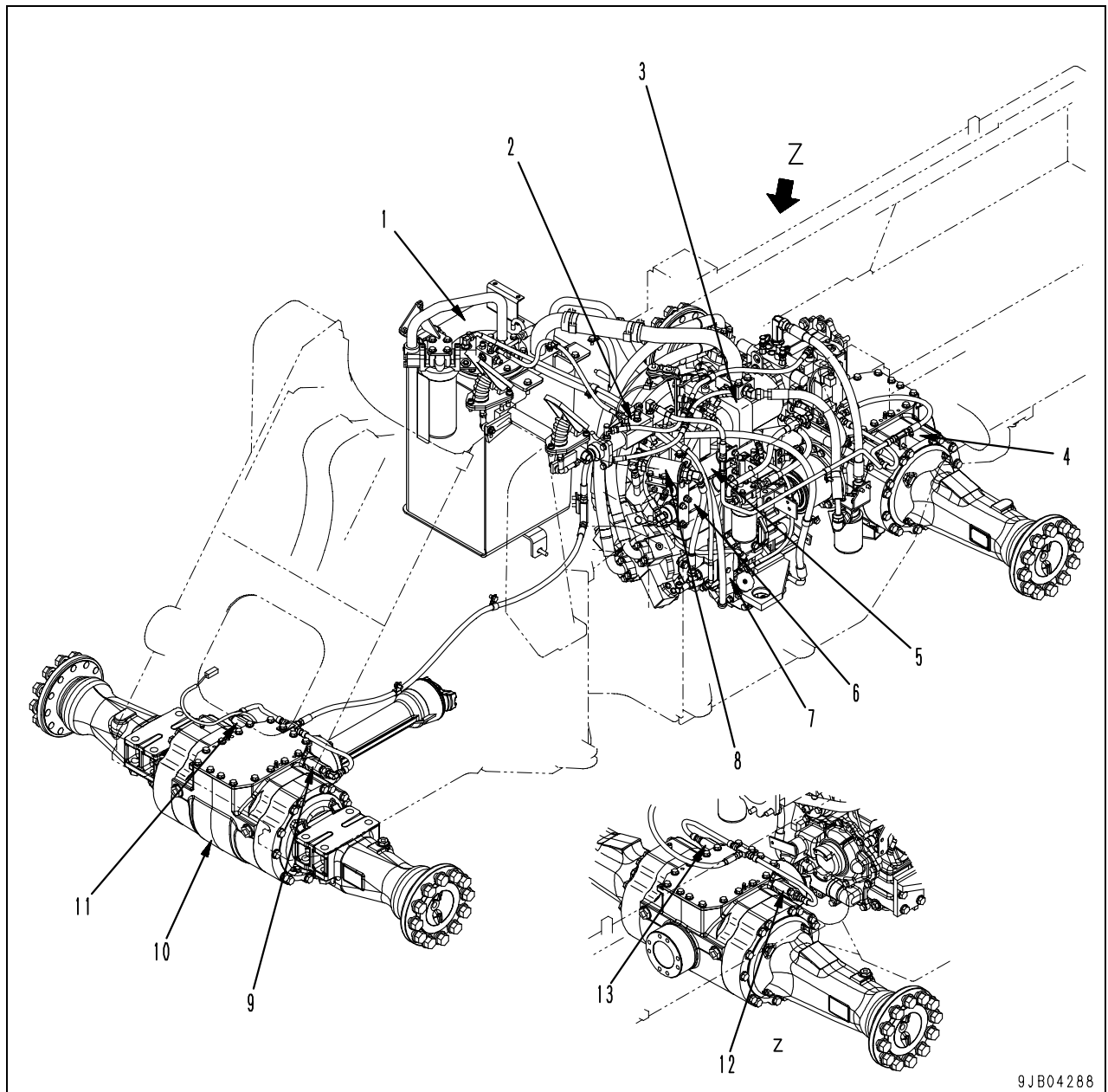

9JB04288

- | | |
|---------------------------------|---|
| 1. Hydraulic tank | 8. Strainer |
| 2. Brake valve | 9. Slack adjuster (for front left side) |
| 3. Brake and cooling fan pump | 10. Front brake |
| 4. Rear brake | 11. Slack adjuster (for front right side) |
| 5. Accumulator (for front side) | 12. Slack adjuster (for rear right side) |
| 6. Accumulator (for rear side) | 13. Slack adjuster (for rear left side) |
| 7. Charge valve | |

Function

- The slack adjuster is installed between the brake valve and brake piston. It maintains the time lag up to activation of the brake constant.

Operation

When brake is applied

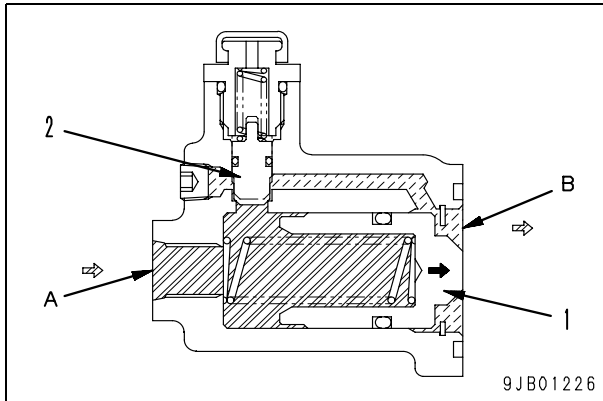

- The oil from the brake valve flows to port (A) and moves piston (1) in the right direction to activate the brake using the oil being amassed between piston (1) and the brake piston.
- The slack adjuster maintains the time lag up to activation of the brake constant by operating the brake using the oil being amassed between piston (1) and the brake piston.
- If the oil between piston (1) and brake piston goes low due to wear on the brake disc and like, it pushes open check valve (2) to make up the deficit.

When brake is released

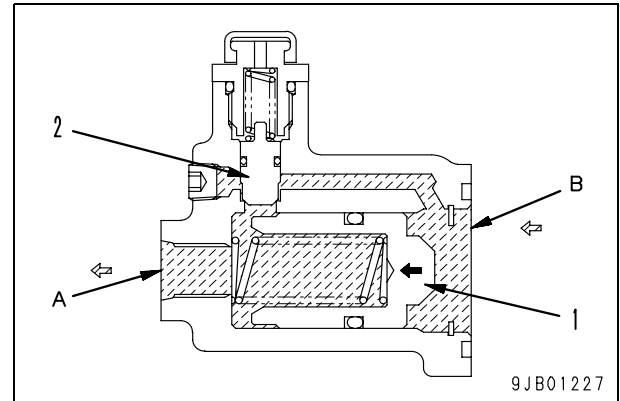

- The oil being stopped between piston (1) and brake piston pushes back piston (1) in the left direction, allowing the oil, equivalent in the volume to piston (1) move distance, to return to the brake valve through port (A) then is drained to the hydraulic tank.

Unit: mm

No.	Check item	Criteria				Remedy
		Standard size	Tolerance		Standard clearance	
	Shaft		Hole			
1	Clearance between upper hinge pin and rear frame (small)	65	-0.030 -0.049	+0.100 0	0.030 – 0.149	—
2	Clearance between upper hinge pin and spacer	65	-0.030 -0.049	+0.240 0	0.030 – 0.289	—
3	Clearance between upper hinge pin and bearing	65	-0.030 -0.049	0 -0.015	0.015 – 0.049	—
4	Clearance between upper hinge pin and rear frame (large)	80.5	-0.080 -0.180	±0.050	0.030 – 0.230	—
5	Clearance between front frame and upper hinge bearing	110	0 -0.020	-0.041 -0.076	-0.076 – -0.021	—
6	Clearance between lower hinge pin and rear frame bushing	65	-0.030 -0.076	+0.067 +0.027	0.057 – 0.143	—
7	Clearance between lower hinge pin and bearing	65	-0.030 -0.076	0 -0.015	0.015 – 0.076	—
8	Clearance between front frame and lower hinge bearing	105	0 -0.020	-0.041 -0.076	-0.076 – -0.021	—
9	Clearance between rear frame and bushing	75	+0.084 +0.059	+0.046 0	-0.084 – -0.013	—
10	Clearance of press fitting part of lower hinge pin seal	80	+0.260 +0.160	+0.046 0	-0.260 – -0.114	—
11	Height of upper hinge spacer	Standard size	Tolerance		Repair limit	
		26	0 -0.25		—	
12	Standard thickness of shim between upper hinge and retainer	0.92				Adjust
13	Standard thickness of shim between upper hinge and retainer	1.45				
14	Standard thickness of shim between lower hinge and retainer	0.85				
15	Tightening torque of upper hinge retainer mounting bolt	14.7 ± 1.5 Nm {1.5 ± 0.15 kgm} (when shim is adjusted)				
		59 – 74 Nm {6.0 – 7.5 kgm} (final value)				
16	Tightening torque of lower hinge retainer mounting bolt	14.7 ± 1.5 Nm {1.5 ± 0.15 kgm} (when shim is adjusted)				
		59 – 74 Nm {6.0 – 7.5 kgm} (final value)				

WA250PZ-6
2-lever type
(if equipped)

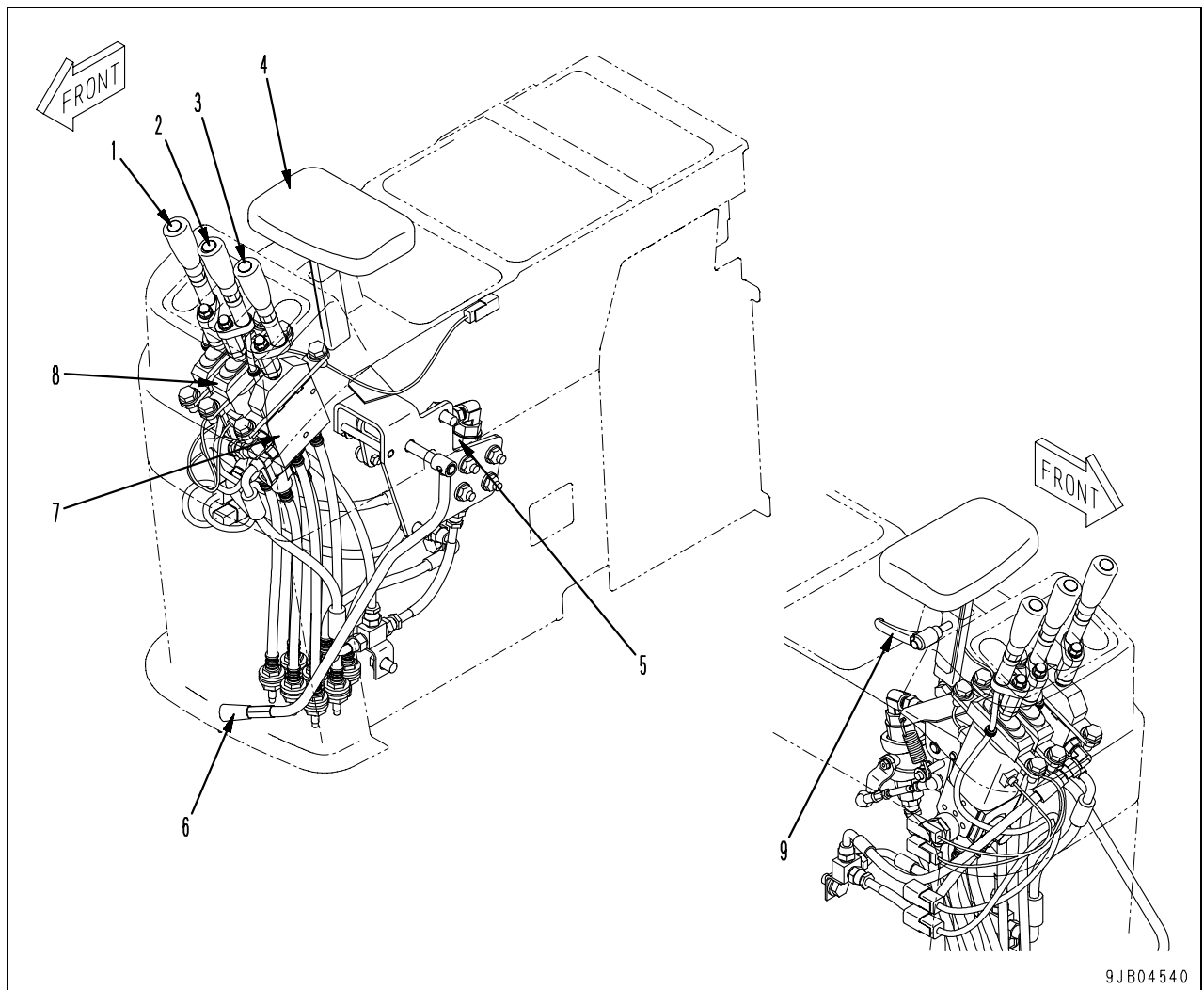

1. Lift arm control lever
2. Bucket control lever
3. Auxiliary control lever
4. Wrist rest
5. Lock valve
6. Work equipment lock lever
7. Attachment PPC valve
8. Work equipment PPC valve
9. Wrist rest height adjustment lever

1. Main relief valve
2. Service spool
3. Bucket spool
4. Lift arm spool
5. Suction safety valve
6. Check valve
7. Suction valve

Unit: mm

No.	Item	Criteria					Remedy
		Standard size			Repair limit		
		Free length x Outside diameter	Installed length	Installed load	Free length	Installed load	
8	Spool return spring	42.5 x 27.5	41	92.2 N {9.4 kg}	—	73.8 N {7.52 kg}	If damaged or deformed, replace spring
9	Spool return spring	56.9 x 26.3	55.3	88.3 N {9.0 kg}	—	70.6 N {7.2 kg}	
10	Spool return spring	55.1 x 12.6	40.0	178 N {18.1 kg}	—	142 N {14.5 kg}	
11	Spool return spring	42 x 27.5	41	72.6 N {7.4 kg}	—	58.1 N {5.92 kg}	
12	Check valve spring	39.5 x 11.2	25	29.4 N {3 kg}	—	23.5 N {2.4 kg}	

Operation of work equipment control valve

1. When lift arm and bucket spool are at the neutral position

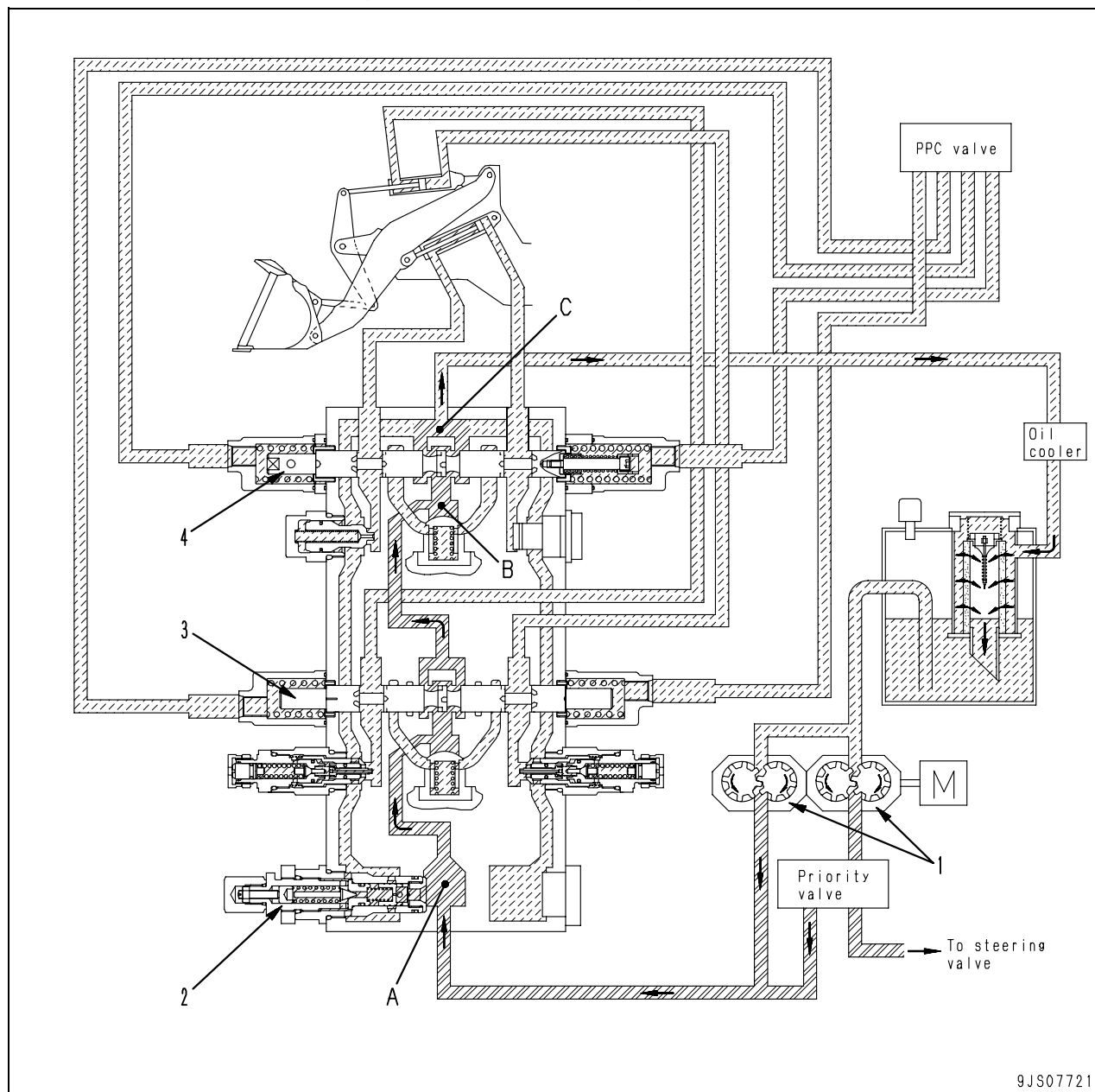

Operation

- The pressurized oil flows to port (A) through pump (1) and the priority valve. And the maximum pressure is regulated by relief valve (2).
- The bypass circuit is open since bucket spool (3) is at the neutral position. Thus, the pressurized oil in port (A) flows to port (B) passing through in vicinity of the spool.
- The bypass circuit is open since lift arm spool (4) is at the neutral position. Thus, the pressurized oil in port (B) enters port (C) of the drain circuit passing through in vicinity of the spool, and returns to the hydraulic tank through the filter.

2-lever type (if equipped)

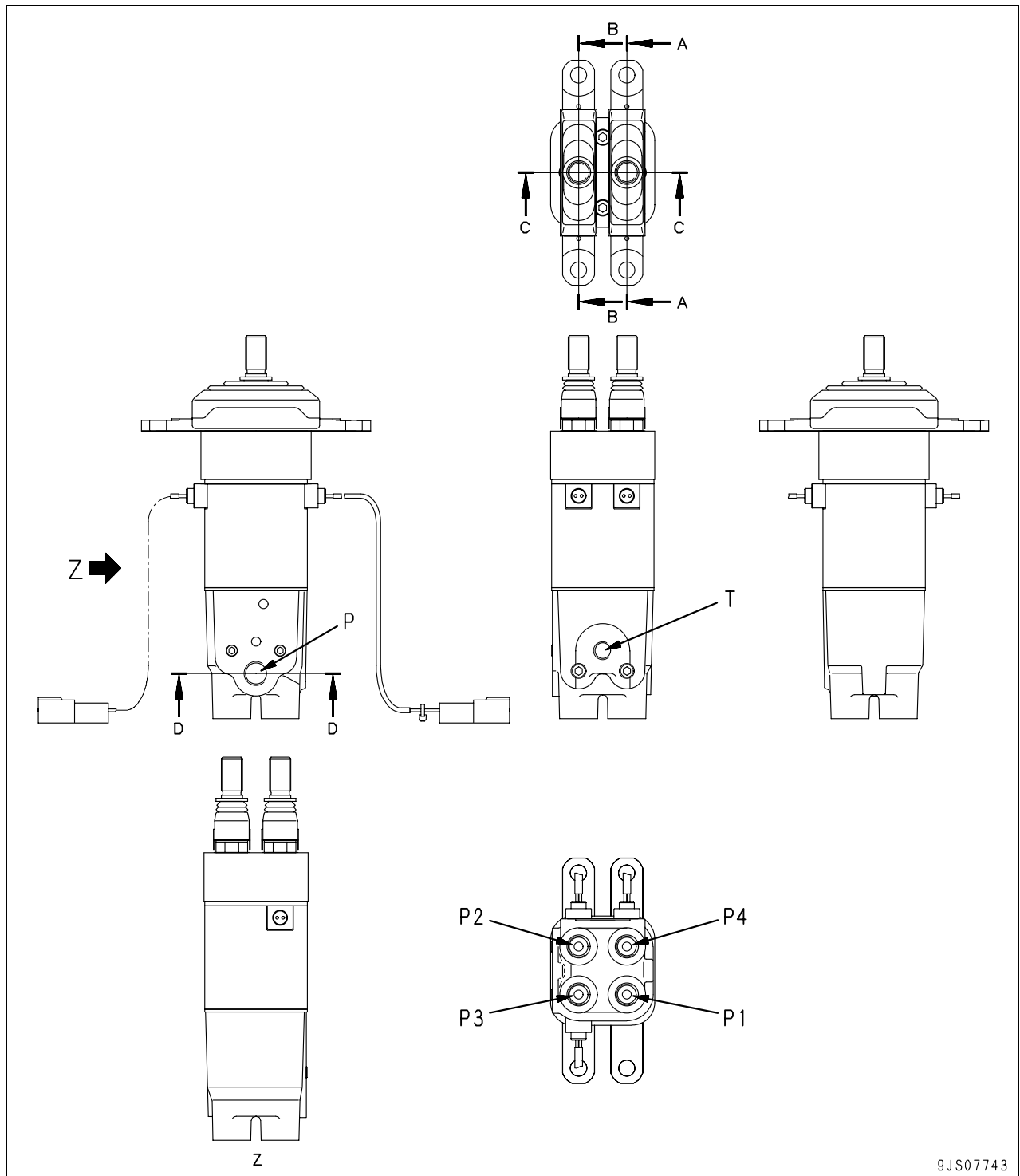

9JS07743

- P: From HST charge pump
- P1: To bucket tilt valve
- P2: To lift arm LOWER (FLOAT) valve
- P3: To lift arm RAISE valve
- P4: To bucket DUMP valve
- T: To hydraulic tank

Operation

When lift arm is "RAISE" operation

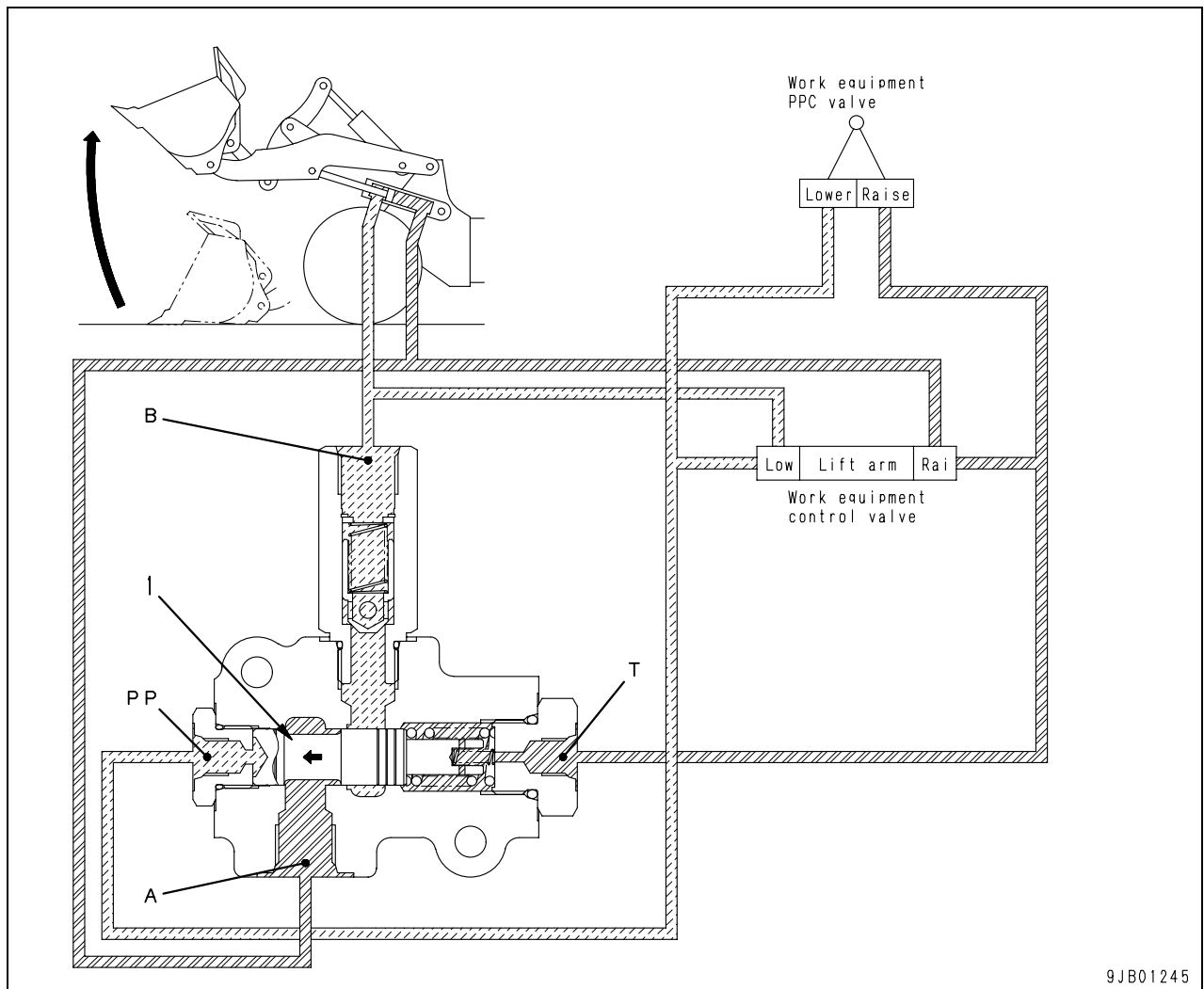

9JB01245

- If the lift arm is "RAISE" operation, the oil of the work equipment PPC valve operates the work equipment control valve and the oil from the work equipment pump flows to the lift cylinder bottom side.
- At this time, the oil of the work equipment PPC valve flows to port (T) to push spool (1) to the left and closes ports (A) and (B).
- The oil on the lift cylinder head side flows through the work equipment control valve into the hydraulic tank, thus the lift arm rises.

Unit: mm

No.	Check item	Criteria		Remedy
		Standard size	Repair limit	
5	Wear of cutting edge (thickness)	31.8	19	Reverse or replace
		90	5	
6	Wear of cutting edge (length)	90	5	
7	Wear of bucket teeth	Tooth	46	Replace
		Tip tooth	48	
8	Clearance in adapter mounting parts	Max. 0.5	—	Adjust or replace

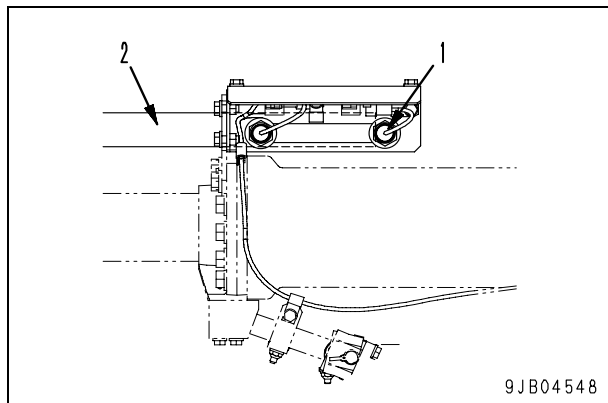

- ★ The power supply for detent solenoid (6) operation is turned "ON" or "OFF" by alternator relay (11).
Detent solenoid (6) circuit is turned off since L signal from alternator (10) is not sent to alternator relay (11) as long as the engine is stopped.
As the result, the work equipment (bucket) control lever (7) cannot be moved and held in the tilt position as long as bar (2) is positioned in sensing face of proximity switch (1).

Function of proximity switch

When object of sensing is over sensing face of proximity switch

Lamp of proximity switch	Turned ON
Bucket positioner relay	ON
Work equipment PPC valve detent solenoid circuit	Power ON
Work equipment PPC valve detent solenoid	Energized

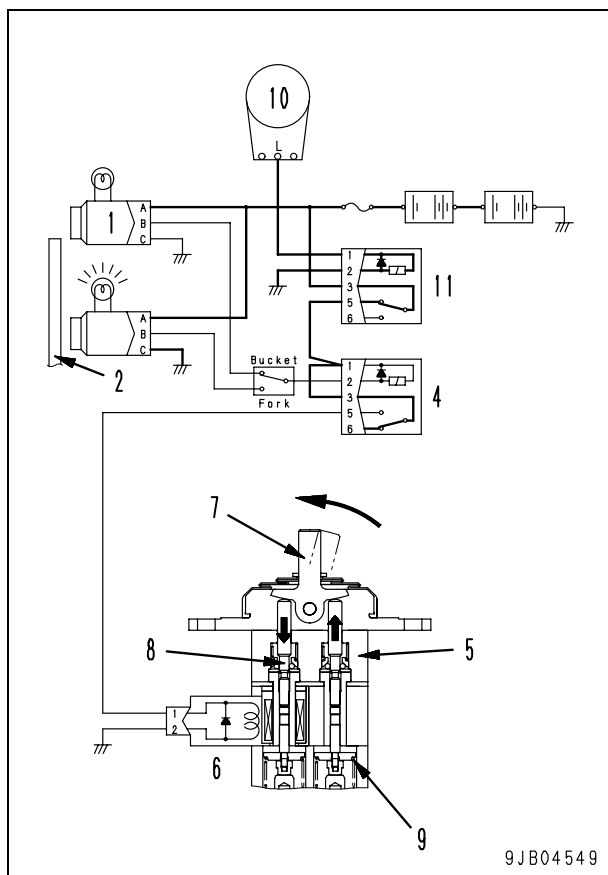

When object of sensing is apart from sensing face of proximity switch

Lamp of proximity switch	Turned OFF
Bucket positioner relay	OFF
Work equipment PPC valve detent solenoid circuit	Power OFF
Work equipment PPC valve detent solenoid	De-energized

- As the bucket is tilted and moved away from the position set by the positioner, in other words, as bar (2) moves away from the sensing face of proximity switch (1), the lamp of proximity switch (1) goes off and bucket positioner relay (4) is set to "OFF" state.
Because of above, detent solenoid (6) circuit on work equipment PPC valve (5) is cut off and the coil is de-energized.
Held bucket spool (8) receives the reaction force of spring (9) and returns work equipment (bucket) control lever (7) to "hold" position.

1. Hot water take-out piping
2. Compressor
3. Condenser
4. Receiver
5. Hot water return piping
6. Refrigerant piping
7. External air filter
8. Internal/external air changeover damper
9. Blower unit
10. Air conditioner unit
11. Dual pressure switch
12. Air outlet duct
13. Cool and hot box (if equipped)
14. Internal air filter

Specifications

Refrigerant used	R134a
Refrigerant refilling level (g)	900

WHEEL LOADER

WA250-6

WA250PZ-6

Machine model	Serial number
WA250-6	75001 and up
WA250PZ-6	75160 and up H00051 and up

10 Structure, function and maintenance standard

910 Electrical system, Part 1

Machine monitor system	2
Machine monitor	6

Character display function

- Machine monitor display and setting can be changed by using the character display.
- The range where operator is enabled to operate is within the portion of the "Operator mode" in the figure below.
- ★ For the operating method in the operator mode, see the Operation and maintenance manual.

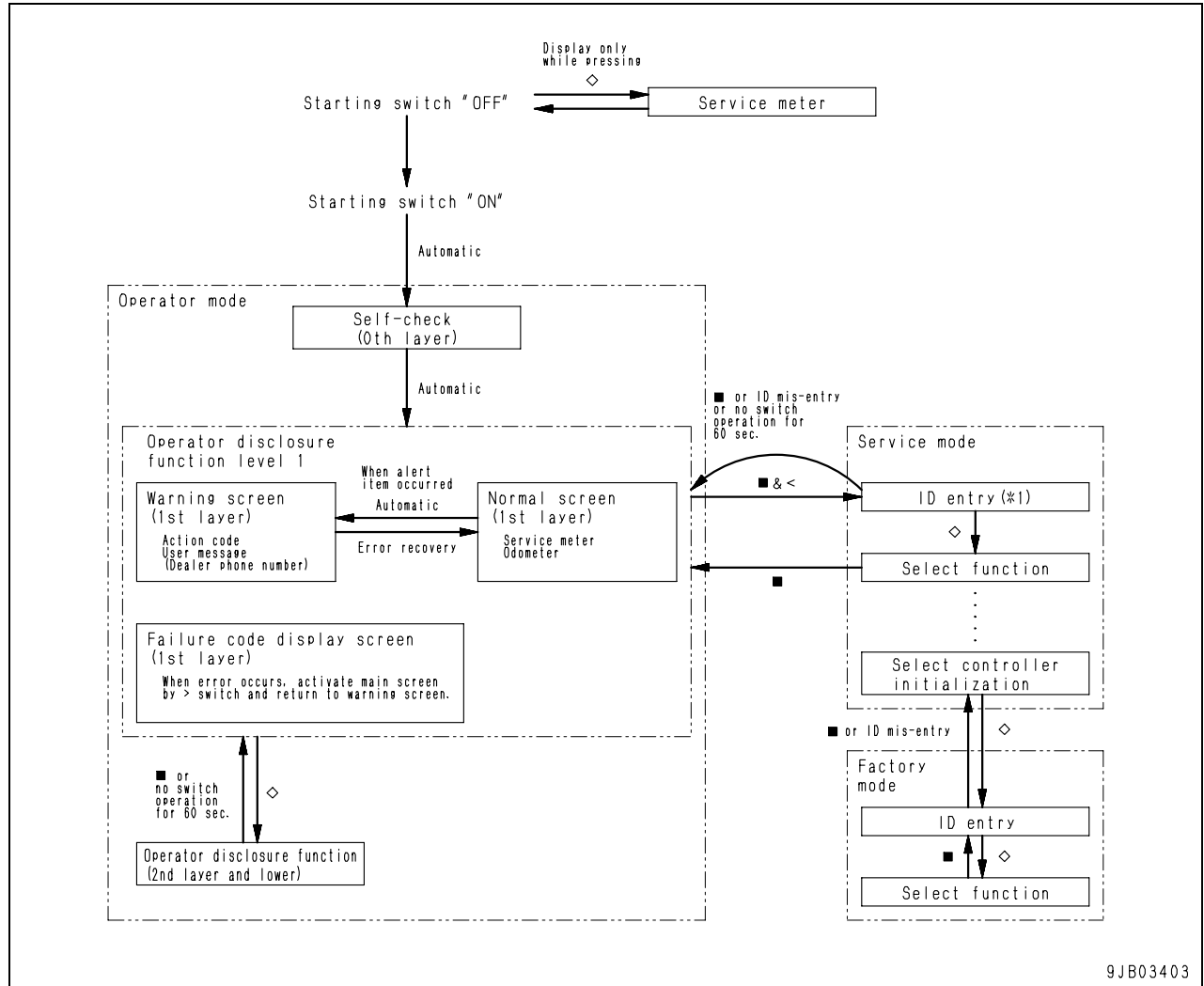

*1: When an ID entered from the "ID entry" screen is once approved, display changes directly to the "Select function" screen without displaying the "ID entry" screen until the starting switch is turned "OFF".

AMP070-12P(3)[CN-L29]

Pin No.	Specifications	I/O	Group	Form of use	Signal name	Remarks
1	(NC)	—	—	—	—	
2	(NC)	—	—	—	—	
3	CAN (+)	I/O	P	CAN	CAN (+)	
4	(NC)	—	—	—	—	
5	(NC)	—	—	—	—	
6	GND	O	—	GND	GND	
7	(NC)	—	—	—	—	
8	CAN (-)	I/O	P	CAN	CAN (-)	
9	(NC)	—	—	—	—	
10	(NC)	—	—	—	—	
11	(NC)	—	—	—	—	
12	(NC)	—	—	—	—	

AMP070-14P[CN-L30]

Pin No.	Specifications	I/O	Group	Form of use	Signal name	Remarks
1	(NC)	—	—	—	—	
2	(NC)	—	—	—	—	
3	(NC)	—	—	—	—	
4	(NC)	—	—	—	—	
5	(NC)	—	—	—	—	
6	(NC)	—	—	—	—	
7	(NC)	—	—	—	—	
8	(NC)	—	—	—	—	
9	(NC)	—	—	—	—	
10	(NC)	—	—	—	—	
11	(NC)	—	—	—	—	
12	(NC)	—	—	—	—	
13	(NC)	—	—	—	—	
14	(NC)	—	—	—	—	

Cooling fan control function

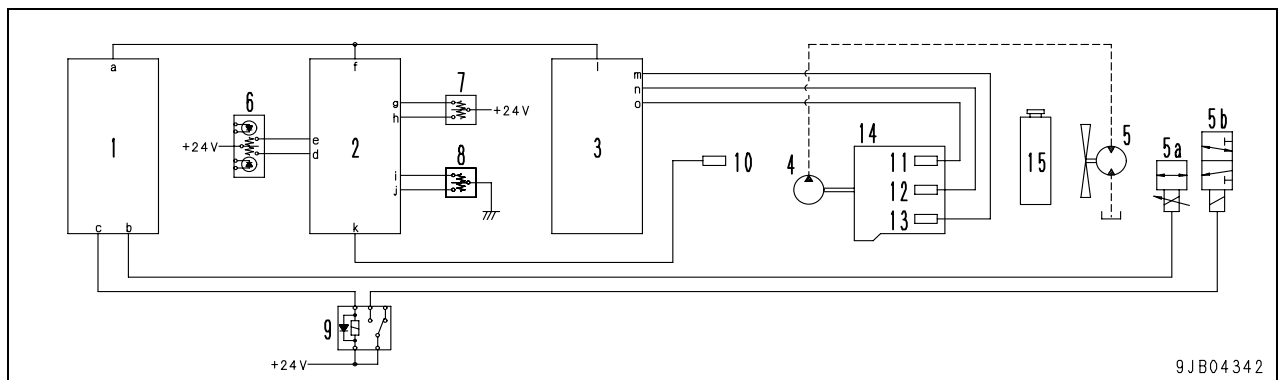

1. HST controller
2. Machine monitor
3. Engine controller
4. Cooling fan pump
5. Cooling fan motor
 - 5a. Cooling fan motor flow rate control EPC valve
 - 5b. Cooling fan reverse solenoid valve
6. Cooling fan reverse switch
7. Machine monitor mode selector switch 1
8. Machine monitor mode selector switch 2
9. Cooling fan reverse solenoid valve relay
10. HST oil temperature sensor
11. Boost pressure and oil temperature sensor
12. Coolant temperature sensor
13. Engine speed sensor
14. Engine
15. Radiator

Input and output signals

HST controller

- a. CAN signal
- b. Cooling fan motor flow rate control signal
- c. Cooling fan reverse signal

Machine monitor

- d. Cooling fan automatic reverse signal
- e. Cooling fan manual reverse signal
- f. CAN signal
- g. "◇" switch signal
- h. "■" switch signal
- i. ">" switch signal
- j. "<" switch signal
- k. HST oil temperature signal

Engine controller

- l. CAN signal
- m. Boost pressure and temperature signal
- n. Engine speed signal
- o. Coolant temperature signal

KOMTRAX terminal

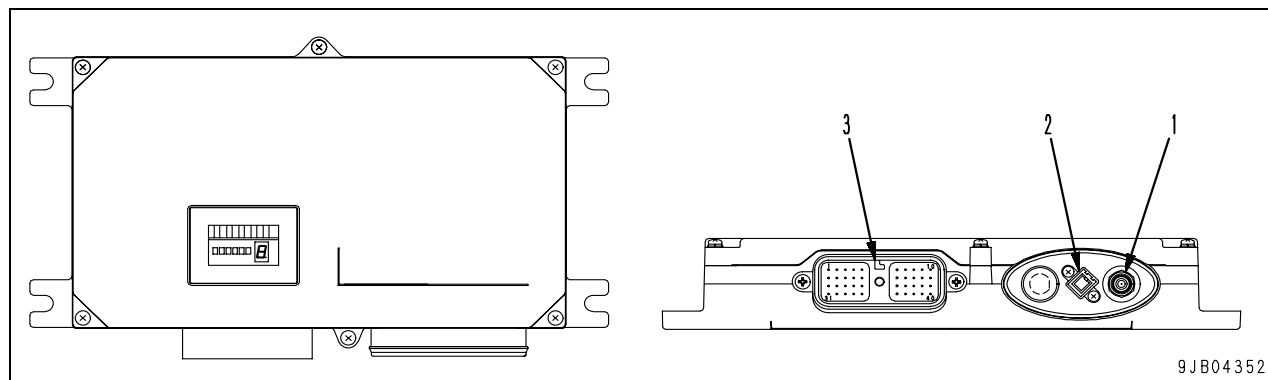

1. Communication antenna connector
2. GPS antenna connector
3. Machine harness connector (DEUTSCH-40P)

Input and output signals

DEUTSCH-40P [CN-L80]

Pin No.	Signal name	Input/Output signal	Pin No.	Signal name	Input/Output signal
1	NC	—	21	Operation mode selection 1	Input
2	NC	—	22	Operation mode selection 2	Input
3	NC	—	23	NC	—
4	NC	—	24	NC	—
5	NC	—	25	NC	—
6	NC	—	26	NC	—
7	CAN0_L	Input/Output	27	Starting switch C signal	Input
8	CAN0_H	Input/Output	28	Alternator L signal	Input
9	NC	—	29	NC	—
10	NC	—	30	NC	—
11	NC	—	31	NC	—
12	NC	—	32	NC	—
13	NC	—	33	NC	—
14	NC	—	34	NC	—
15	NC	—	35	NC	—
16	NC	—	36	Starting switch ACC signal	Input
17	NC	—	37	Power supply GND	—
18	NC	—	38	Power supply GND	—
19	NC	—	39	Constant power supply (24 V)	Input
20	Immobilize signal	Output	40	Constant power supply (24 V)	Input

Outline

- The KOMTRAX terminal can send information via wireless communication antenna, acquiring various information of the machine from the network signal in the machine and the input signal. Also, the terminal incorporates CPU (Central Processing Unit) and provide the wireless communication function and the GPS (Global Positioning System) function.
- There are the LED lamp and the 7-segment indicator lamp in the display area, and these lamps are used for the testing and the troubleshooting.

Sensor

Speed sensor

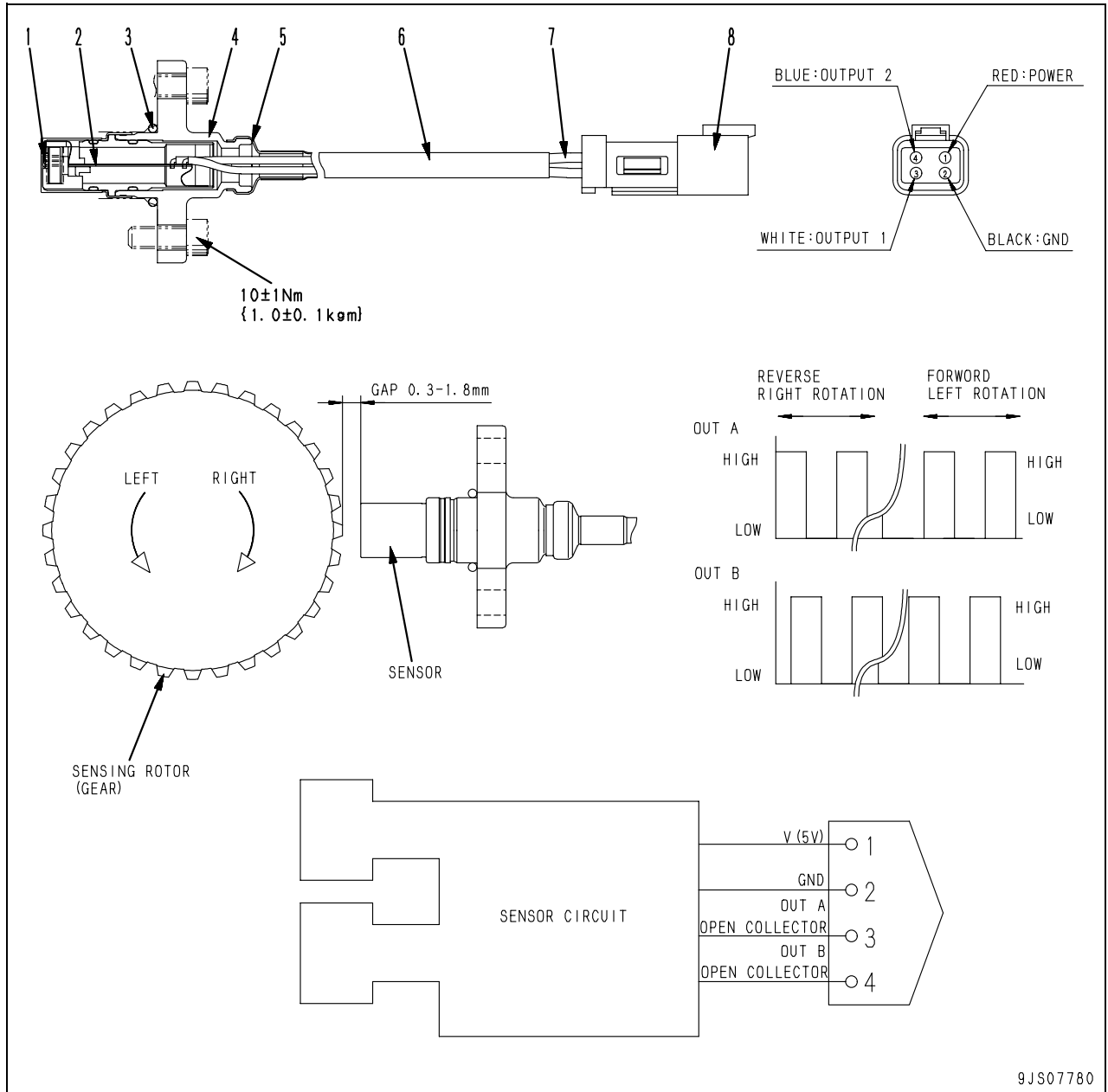

1. Hall IC
2. Circuit board
3. O-ring
4. Housing

5. Heat shrink tube
6. Protective tube
7. Lead wire
8. Connector

Function

- The speed sensor is installed on the transfer case. It generates two different types of pulses depending on the rotational direction and speed of the gear.

Machine posture and procedure for performance measurement

★ Fig. A

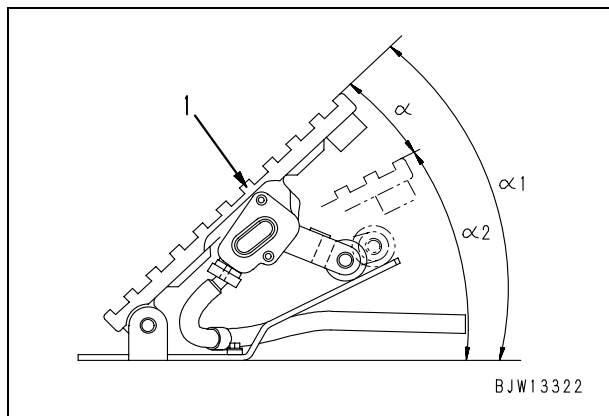

★ Fig. D

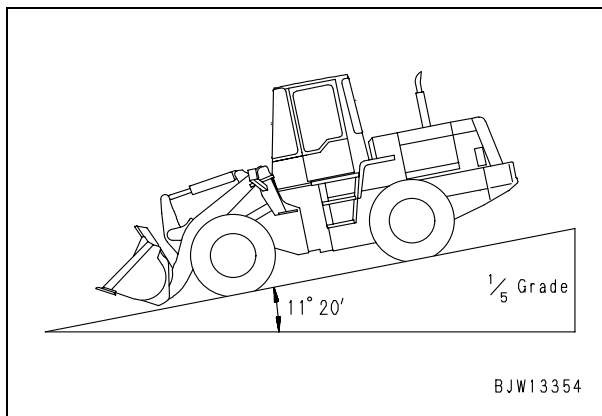

★ Fig. B

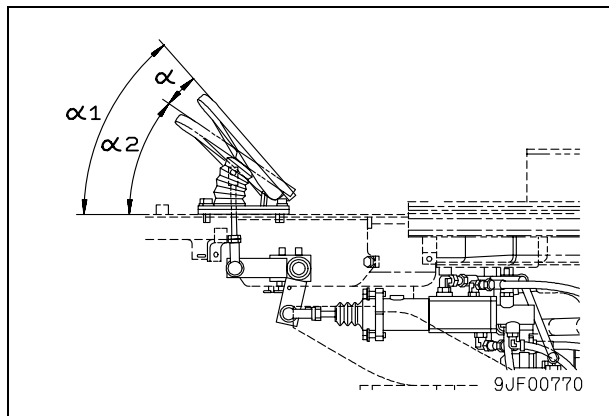

★ Fig. E

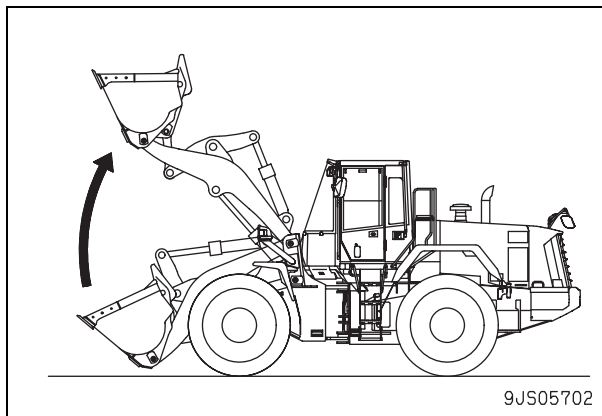

★ Fig. C

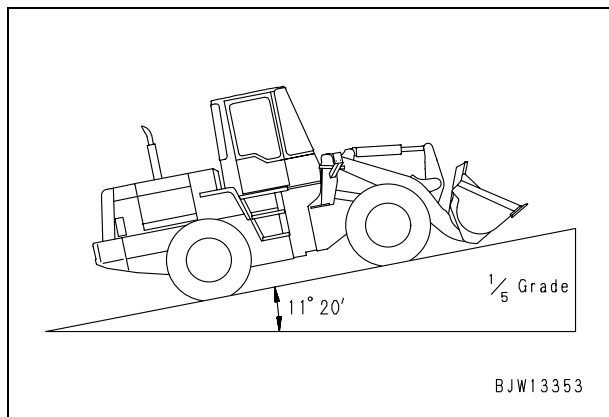

★ Fig. F

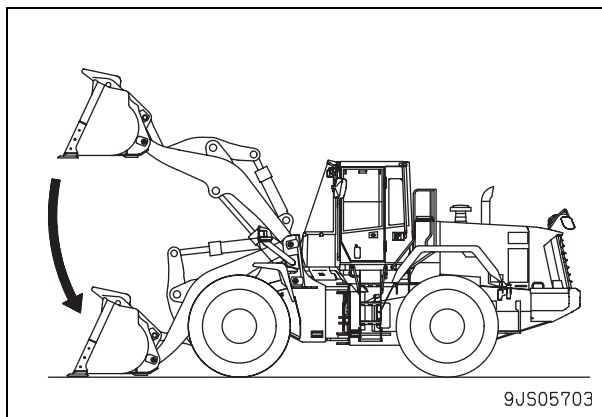

Adjusting valve clearance

★ Necessary tools

Symbol	Part No.	Part Name	
B	1	795-799-1131	Gear
	2	Commercially available	Clearance gauge

★ Adjust the valve clearance under the following condition.

- Engine coolant temperature: Normal temperature

1. Remove cylinder head cover (1). For details, see Disassembly and assembly, "Removal and installation of cylinder head assembly".

- ★ Removal of the engine hood is unnecessary.

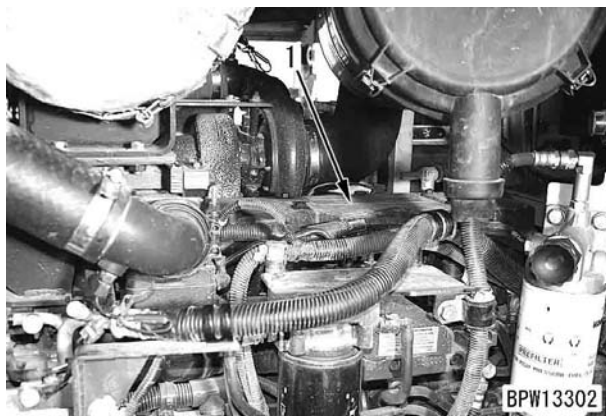

2. Remove plate (2) and plug (3) at the bottom of the starting motor and insert gear **B1**.

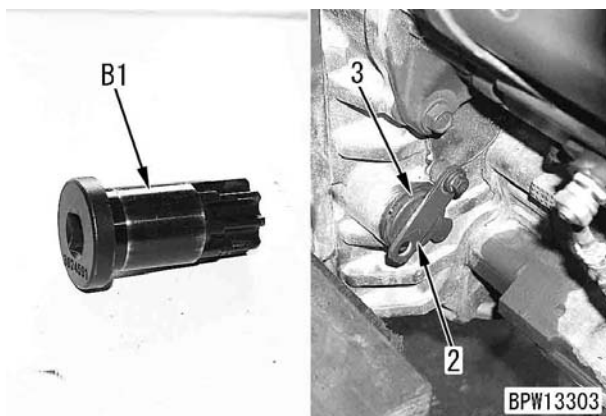

3. Rotate the crankshaft forward (clockwise, seeing from the fan) with gear **B1** and set wide slit (b) of the rotation sensor ring to projection top (a) of front cover.

- ★ Projection top (a) must be within the range of wide slit (b) when it is seen from the air conditioner compressor side.
- ★ If you can see the yellow marks (c) of projection top (a) and the damper periphery, you may set them to each other.
- ★ After the above positioning, the No. 1 cylinder or No. 6 cylinder is not at the top dead center (TDC). Take care. (The cylinder is at 76 – 88° before the top dead center.)

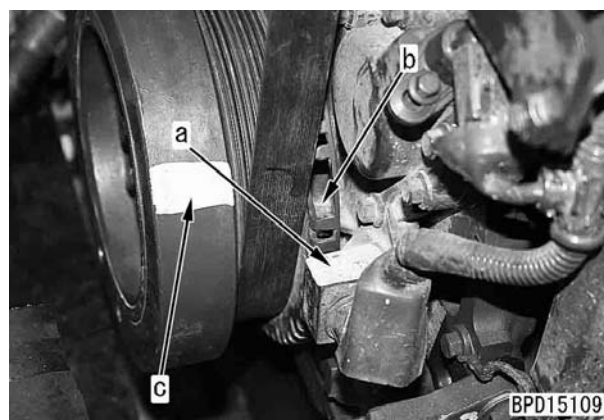

4. Check the movement of the rocker arm of the No. 1 cylinder to judge the valve to be adjusted.

- ★ If you can move the rocker arms of air intake valves (IN) with the hand by the valve clearance, adjust the valves marked with ○ in the valve arrangement drawing.
- ★ If you can move the rocker arms of exhaust valves (EX) with the hand by the valve clearance, adjust the valves marked with ● in the valve arrangement drawing.
- ★ Valve arrangement drawing

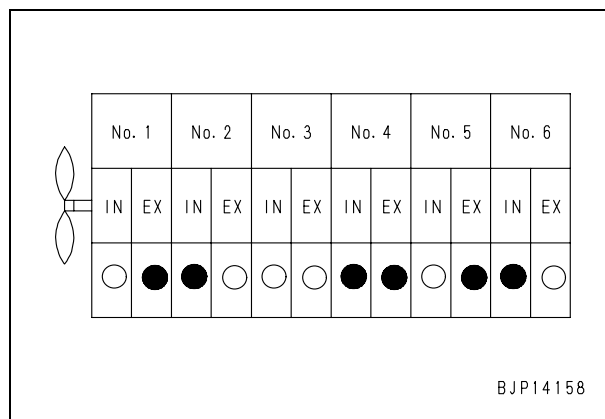

Measuring fuel return rate and leakage

★ Necessary tools

Symbol	Part No.	Part name	
H	1	795-790-4700 Tester kit	
	2	795-790-6700 Adapter	
	3	6754-71-5340	Connector
		6754-71-5350	Washer
	4	Commercially available	Measuring cylinder
	5	Commercially available	Stopwatch
6	Commercially available	Hose (Inside diameter 14 mm)	

★ Prepare receiving pan of about 20 liters to receive the fuel flowing out during measurement.

- ⚠ Put chocks under the tires securely.
- ⚠ When measuring, check that there are no persons around the machine.

1. Measuring supply pump delivery

- 1) Open the engine right side cover.
- 2) Loosen clamp (1) of supply pump discharge tube (2) and disconnect the tube.

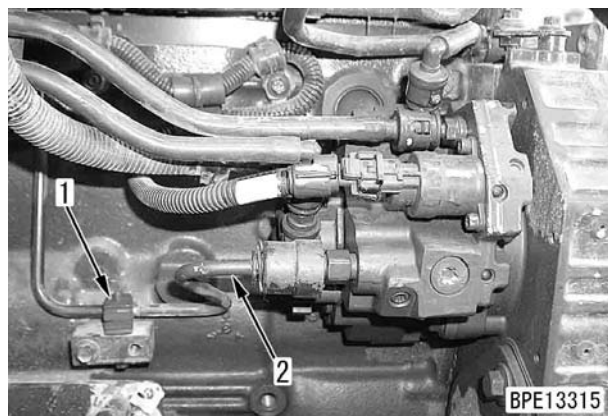

- 3) Install test hose **H6** to the nipple on the discharge side of the supply pump.
 - ★ Fix the hose with a wire etc.
 - ★ Adjust the route of the test hose so that it will not slacken and put its end in receiving pan.

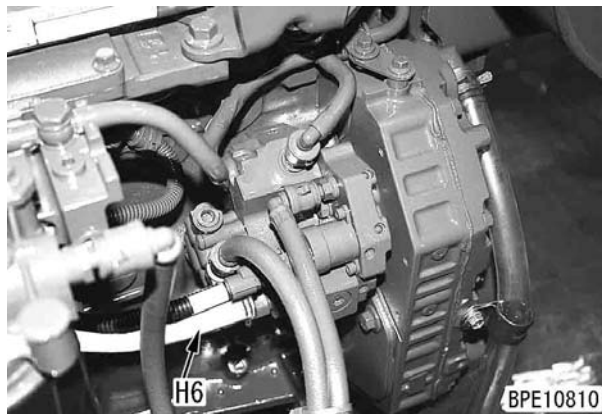

- 4) Crank the engine for 30 seconds and measure the delivery with measuring cylinder **H4**.
 - ★ Adjust the route of the test hose so that it will not slacken and put its end in receiving pan.
 - ★ Do not crank the engine for more than 30 seconds to protect the starting motor in any case other than this measurement.
 - ★ If the supply pump delivery is in the following standard range, it is normal.

At cranking speed (125 rpm)	Min. 75 cc
At cranking speed (150 rpm)	Min. 90 cc

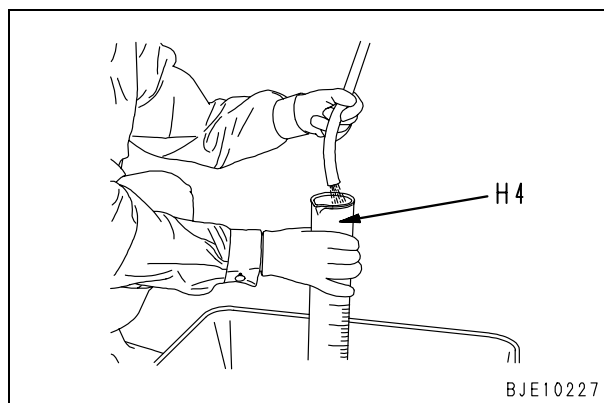

- 5) After finishing measurement, remove the measuring instruments and return the removed parts.
 - 🔧 Tube sleeve nut:
35 ± 4 Nm {3.6 ± 0.4 kgm}
 - 🔧 Clamp mounting bolt:
10 ± 2 Nm {1.0 ± 0.2 kgm}

WHEEL LOADER

WA250-6

WA250PZ-6

Machine model	Serial number
WA250-6	75001 and up
WA250PZ-6	75160 and up H00051 and up

30 Testing and adjusting

120 Testing and adjusting, Part 2

Checking operating force of accelerator pedal	3
Checking directional lever	4
Testing and adjusting HST oil pressure	5
Testing clutch control pressure	9
Testing and adjusting steering wheel	10
Testing and adjusting steering oil pressure	12
Bleeding air from steering circuit	14
Testing hydraulic fan	15
Measuring brake pedal	17
Testing and adjusting brake pedal linkage	18
Measuring brake performance	19
Testing and adjusting accumulator charge pressure	20
Testing wheel brake oil pressure	22
Testing wear of brake disc	25
Bleeding air from wheel brake circuit	26
Releasing residual pressure in brake accumulator circuit	27
Testing parking brake performance	28
Testing and adjusting parking brake control cable	29
Measuring and adjusting work equipment control lever	30
Testing and adjusting work equipment hydraulic pressure	31
Testing work equipment PPC oil pressure	32
Bleeding air from hydraulic circuit	34
Releasing remaining pressure in hydraulic circuit	35

Adjusting main relief pressure

1. Stop the engine.
2. Remove cover (1) at the lower right of the operator's cab.



3. Disconnect hose (3) and fitting (4) connected to port (T) of the priority valve (2).

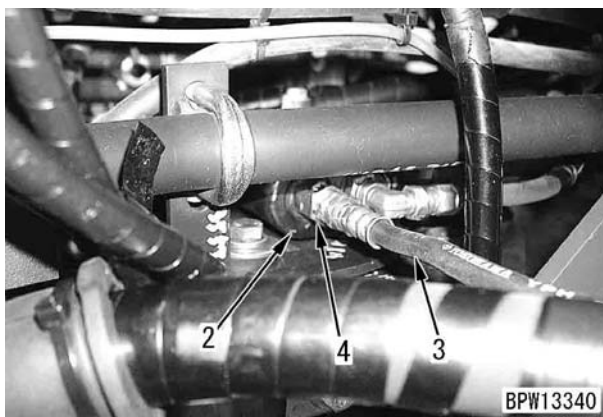

4. Loosen lock screw (5), and then turn adjustment screw (6) to adjust.
 - ★ Turn the adjustment screw to adjust as follows.
 - To INCREASE pressure, turn CLOCKWISE.
 - To DECREASE pressure, turn COUNTERCLOCKWISE.
 - ★ Pressure adjustment for one turn of adjustment screw: Approx. 6.9 MPa {70 kg/cm²}
 - ★ Tool [1] for adjusting adjustment screw: Size 7/32 inch, hexagonal
 - ★ Do not carry out any adjustment if the relief pressure cannot be measured accurately.

- ⌘ Adjustment screw (6):
2.3 – 6.8 Nm {0.23 – 0.69 kgm}
- ⌘ Lock screw (5):
14.7 ± 2 Nm {1.5 ± 0.2 kgm}

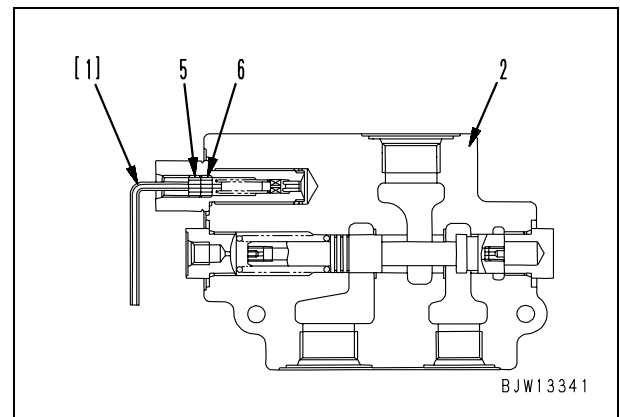

5. After finishing the work, remove the measuring instruments and return the removed parts.

Testing wear of brake disc

Necessary tools

Symbol	Part No.	Part name
U	418-98-31110	Testing gauge

⚠ Stop the machine on a level ground, lower the work equipment to the ground, and set chocks under the tire securely.

★ There are inspection plugs on the right and left sides of the front and rear axles. Check at all of the 4 plugs similarly.

1. Remove inspection plug (1) from the axle housing.

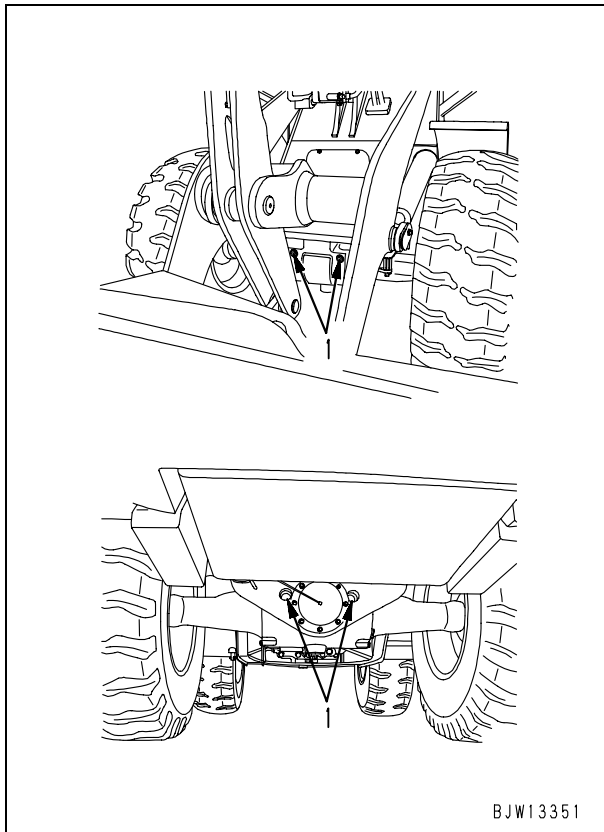

2. While pressing the brake pedal, insert testing gauge **U** in the inspection plug hole and pinch the inspection projection around piston (2) and plate (3) with the inspection gauge tip.

Reference: Testing gauge **U** is component part of tool kit.

★ If you can pinch the inspection projection around piston (2) and plate (3) with the inspection gauge tip, the brake disc is worn more than the repair limit. In this case, replace the brake disc.

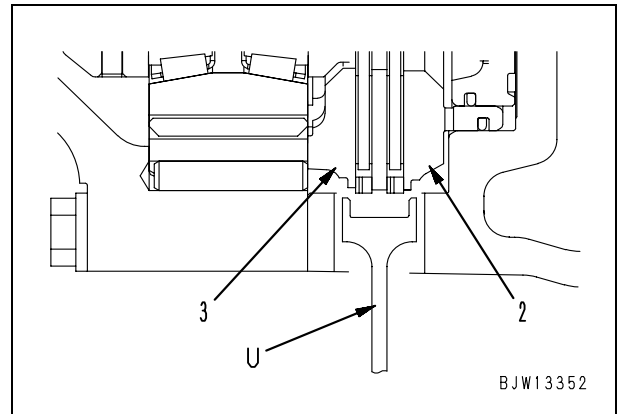

3. After finishing the work, remove the measuring instruments and return the removed parts.

🔧 Inspection plug (1):

127.4 – 176.4 Nm {13 – 18 kgm}

Testing and adjusting of boom kick-out switch

Testing

1. With the engine stopped, check that clearance (a) between detection surface of switch (1) and plate (2) is the standard value.
★ Standard clearance (a): 3 – 5 mm

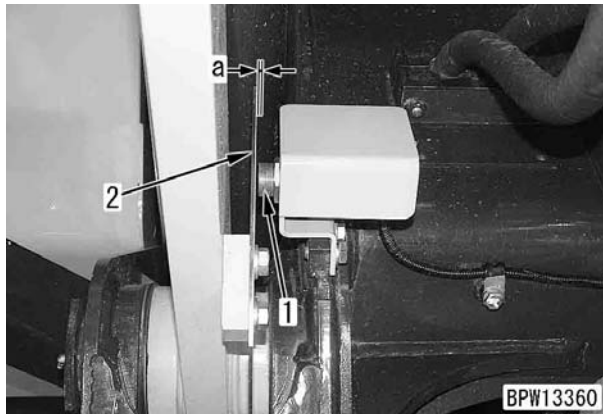

2. Start the engine, run at high idle, and check the actuation point.
(Check three times and take the average.)

Adjusting

1. Raise the lift arm to the desired height, then mark the lift arm to show the position where the center of the switch is aligned with the bottom of the plate.
⚠ Always be sure to apply the work equipment lock lever.
2. Lower the lift arm and stop the engine.
3. Align the marks and adjust the position of the plate so that the center of switch (1) is at the bottom of plate (2), then secure in position with bolt (3).

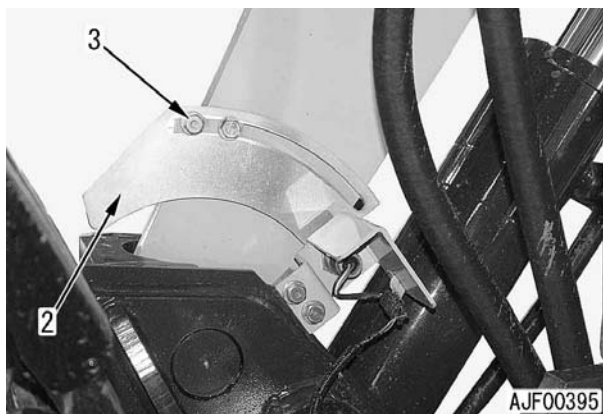

4. Adjust the switch so that clearance (a) between the sensing surface of the switch and plate (2) is the standard value, then secure in position.
☞ Switch mounting nut:
14.7 – 19.6 Nm {1.5 – 2.0 kgm}
 - The installing position may be checked by checking the operation of the pilot lamp of the proximity switch with the starting switch at the ON position.
 - ★ For ON/OFF of the pilot lamp, see “Checking proximity switch working pilot lamp”.
 - ★ After adjusting, start the engine, operate the work equipment kickout control lever and check that the boom kickout is actuated at the desired position.

Indicator lamps of KOMTRAX terminal

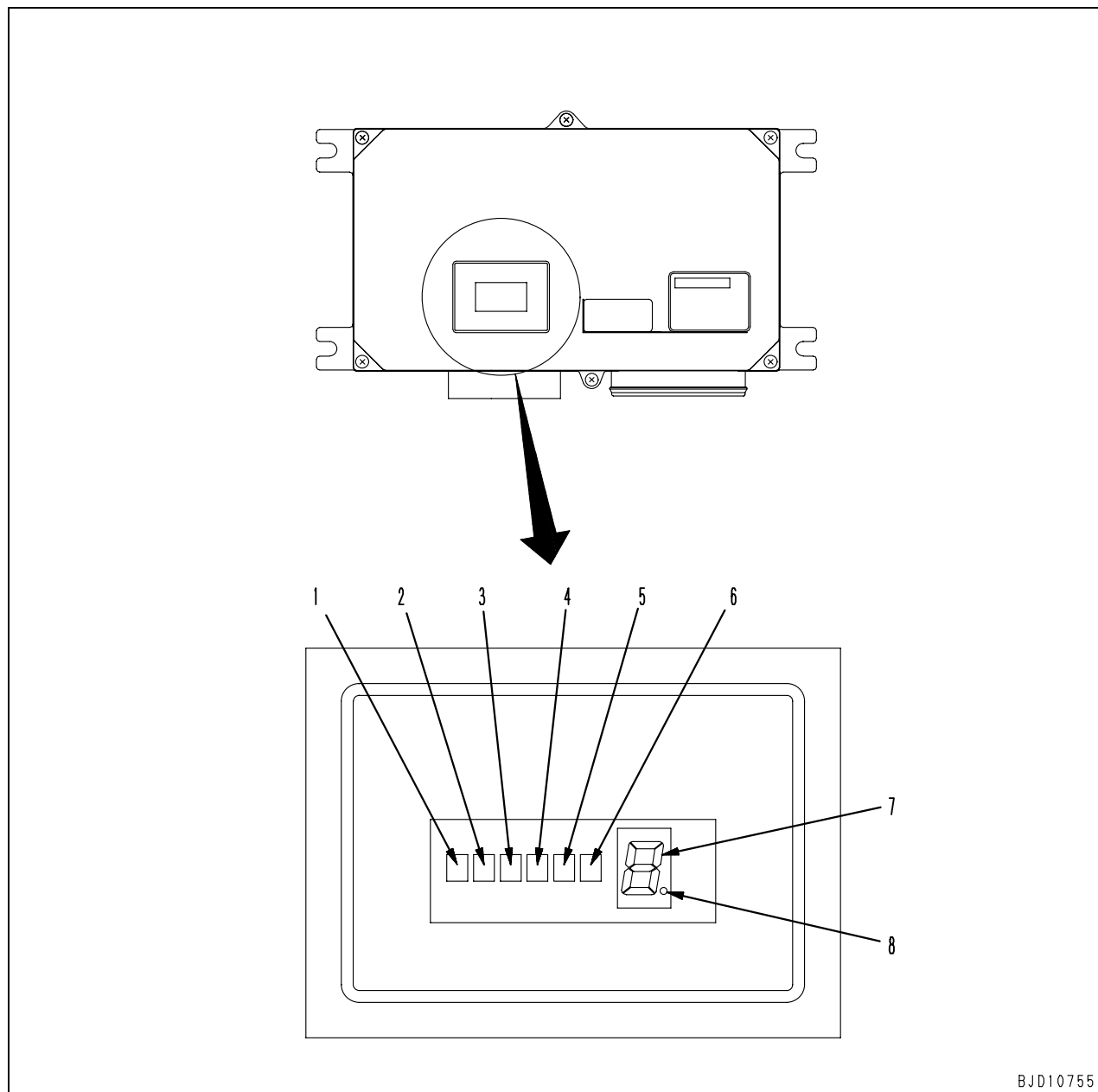

LED lamps for CPU

1. LED-C1 (State of R or ACC signal)
2. LED-C2 (Starting output state)
3. LED-C3 (State of S-NET or C signal)
4. LED-C4 (CAN state)
5. LED-C5 (Download write state)
6. LED-C6 (Download write state)

7-segment and dot displays for CPU

7. 7 segments (Number of unsent mails)
8. Dot (GPS positioning state)

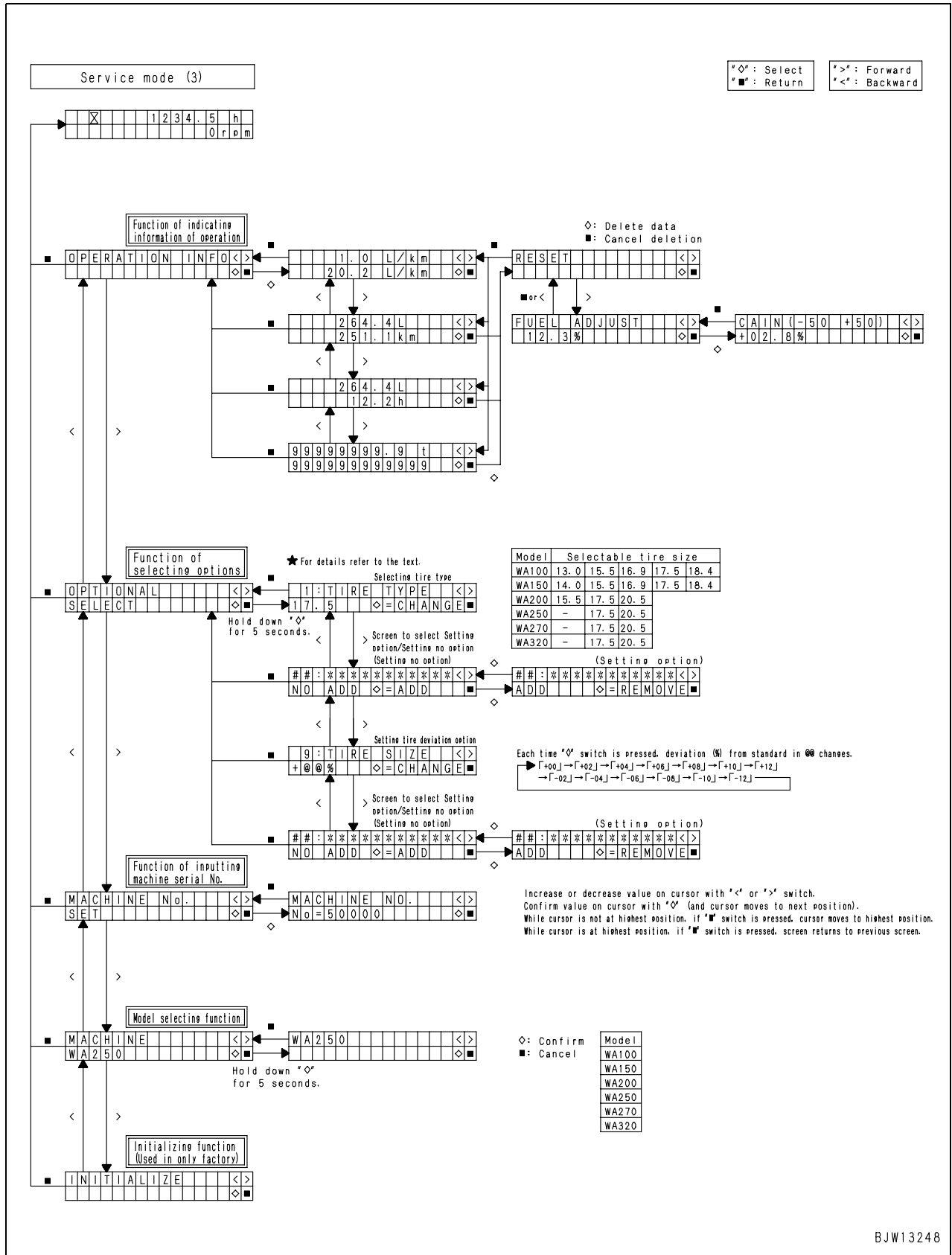

Failure code	Troubled part/item	Trouble	Controller	Action code	Category of record
CA553	Common rail pressure	Abnormally high pressure 1	ENG	E03	Electrical system
CA559	Supply pump	Low rail pressure 1	ENG	E03	Electrical system
CA689	Engine Ne speed sensor	Abnormality	ENG	E03	Electrical system
CA731	Engine Bkup speed sensor	Abnormal phase	ENG	E03	Electrical system
CA757	Engine controller	Loss of all data	ENG	E03	Electrical system
CA778	Engine Bkup speed sensor	Abnormality	ENG	E03	Electrical system
CA1633	KOMNET	Abnormality	ENG	E03	Electrical system
CA2185	Throttle sensor power supply	Abnormally high level	ENG	E03	Electrical system
CA2186	Throttle sensor power supply	Abnormally low level	ENG	E03	Electrical system
CA2249	Supply pump	Low rail pressure 2	ENG	E03	Electrical system
CA2311	IMV (IMA) solenoid	Abnormality	ENG	E03	Electrical system
CA2555	Intake air heater relay	Disconnection	ENG	E01	Electrical system
CA2556	Intake air heater relay	Short circuit	ENG	E01	Electrical system
D160KY	Backup lamp/buzzer relay	Hot short	MON	E01	Electrical system
D192KY	ECSS solenoid relay	Hot short	MON	E01	Electrical system
D1B0KA	HST safety relay	Disconnection	HST	E03	Electrical system
D1B0KB	HST safety relay	Ground fault	HST	E01	Electrical system
D1B0KY	HST safety relay	Hot short	HST	E03	Electrical system
D5ZHL6	IGN C system	Ground fault/Disconnection	MON	E01	Electrical system
DAF3KK	UNSW power supply	Ground fault/Disconnection	MON	E01	Electrical system
DAFRKR	Monitor panel CAN-NET signal	Disconnection	HST	E03	Electrical system
DAJ0KK	HST controller power supply	Low voltage	HST	E03	Electrical system
DAJ0KT	HST controller memory (EEPROM)	Abnormality	HST	E01	Electrical system
DAJ1L4	HST controller main power suply line	Disconnection/Ground fault	HST	E01	Electrical system
DAJ1L6	HST controller main power suply line	Hot short	HST	E01	Electrical system

MONITOR PANEL [Machine monitor system]				
No.	Monitoring code	Input/Output signal	Displayed item	Contents of ON/OFF switch
5	40904	D-IN-32	—	—
		D-IN-33	—	—
		D-IN-34	High beam (Dimmer switch)	High beam = ON (GND)/OFF (OPEN)
		D-IN-35	Omission of applying parking brake (dummy)	Resetting parking brake = ON (GND)/OFF (OPEN)
		D-IN-36	Parking brake (dummy)	Resetting parking brake = ON (GND)/OFF (OPEN)
		D-IN-37	[>] switch	Pressing switch = ON (GND)/OFF (OPEN)
		D-IN-38	[<] switch	Pressing switch = ON (GND)/OFF (OPEN)
		D-IN-39	Low steering pressure (Machine with optional emergency steering spec.)	Oil pressure reduction = ON (GND)/OFF (OPEN)
6	40952	D-OUT-0	Alarm buzzer	Output ON = ON (24 V)/OFF (OPEN)
		D-OUT-1	—	—
		D-OUT-2	Backup alarm/lamp relay	Output ON = ON (24 V)/OFF (OPEN)
		D-OUT-3	ECSS solenoid relay (Machine with optional ECSS spec.)	Output ON = ON (24 V)/OFF (OPEN)

*: "1" is displayed when ON and "0" is displayed when OFF.

- 3) Select "07: ECSS SPEED" with [<] or [>] switch.

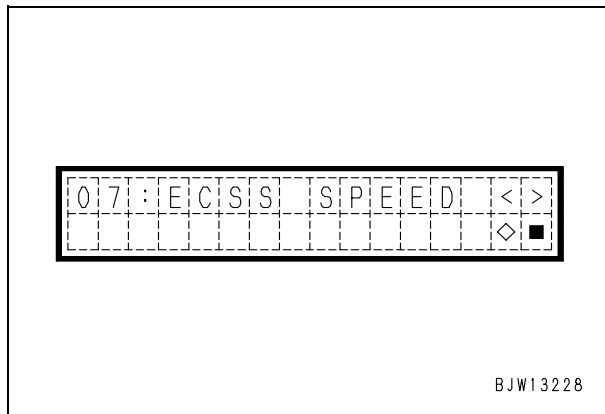

- 4) Press [◇] switch to settle.
★ If the selection is settled, the ECSS operation travel speed adjustment screen appears.

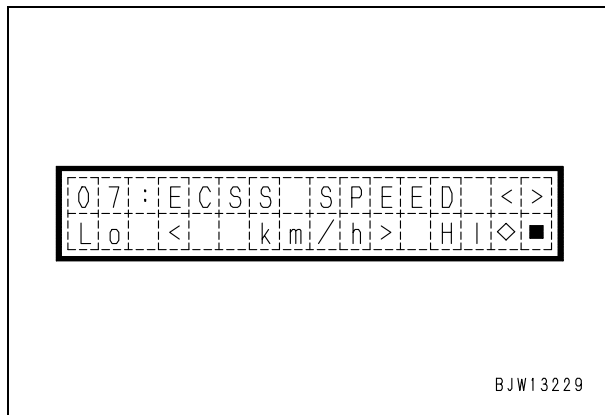

- 5) To increase the ECSS operation travel speed, press [>] switch.
★ The operation travel speed is increased 1 km/h (0.6 MPH) by 1 operation of the switch.
★ The operation travel speed can be adjusted to a maximum of 8 km/h (5.0 MPH).
- 6) To decrease the ECSS operation travel speed, press [<] switch.
★ The operation travel speed is decreased 1 km/h (0.6 MPH) by 1 operation of the switch.
★ The operation travel speed can be adjusted to a minimum of 5 km/h (3.1 MPH).
- 7) If the operation travel speed is set to a desired value, press [■] switch to finish setting.

8. Maintenance monitoring function

The maintenance function offers the following capabilities in the maintenance of filters and oils.

- Change of maintenance interval time
- Selection between enabling or disabling timer by item
- Setting of a default value
- Selection between enabling or disabling timer for items

8-1. Changing maintenance interval time

- 1) Display the MAINTENANCE MONITOR screen from the menu screen of Service mode.

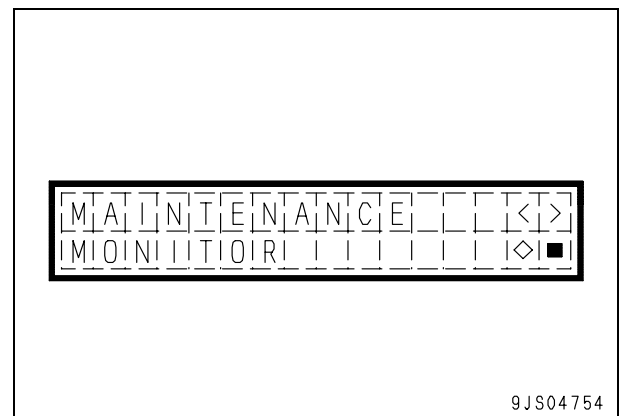

- 2) Press [◇] switch to display 01: ENG OIL screen.
★ The lower left side space indicates the time remained up to the replacement.
★ The lower right side space indicates the cumulative replacement frequencies.
- 3) Using [<] or [>] switch, select the item for which the maintenance interval is to be changed from the following.

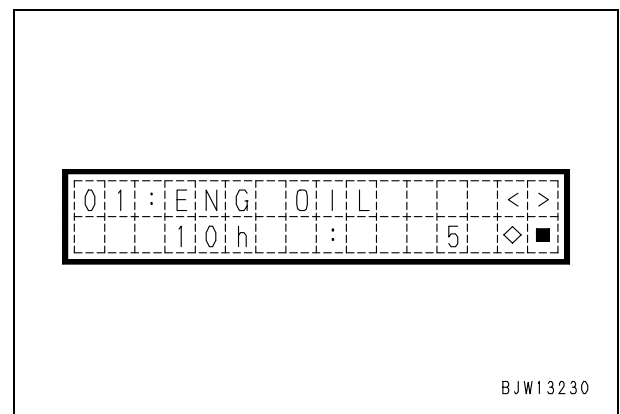

10-6. Storing option selection

- 1) When the option selection was changed, turn off the starting switch once to stop the controller operation completely. (After turning off the starting switch, wait for 15 seconds without doing any switch operation.)
 - 2) The specified option selection is enabled as the starting switch is turned on.
- ★ Whenever an option selection is made, turn off the starting switch once and then turn it on again in approximately 15 seconds.

11. Machine serial number input function

- 1) Display the MACHINE No. SET screen from the menu screen of Service mode.

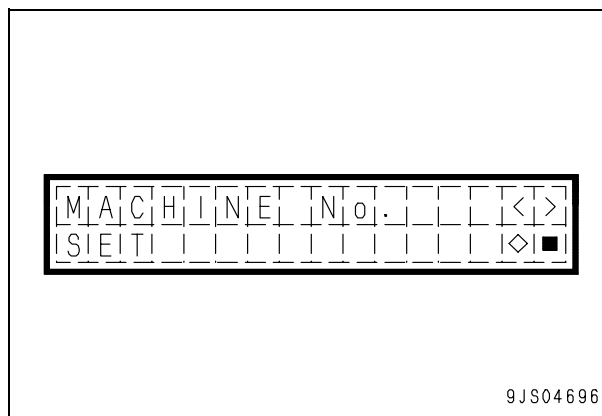

- 2) Press [◇] switch to display the MACHINE No. screen.
- 3) Enter the serial number according to the following procedure.
 - ★ The cursor is positioned at the highest-order digit.
 - 1) Pressing [<] or [>] switch increases or decreases the value at the cursor position. Select a desired value using these switches.
 - 2) Press [◇] switch to settle the selection.
 - ★ The cursor moves to the digit situated immediately on the right hand.
 - 3) Set the values up to the lowest digit in the same order as above and then press [◇] switch to settle.
 - ★ As the selection is settled, the immediately preceding screen is restored.
 - ★ Pressing [■] switch while entry is taking place will move the cursor the highest-order digit. In this case, repeat entry from the highest-order digit.
 - ★ If [■] switch is pressed while the cursor is at the highest-order digit, the immediately preceding screen will be restored.

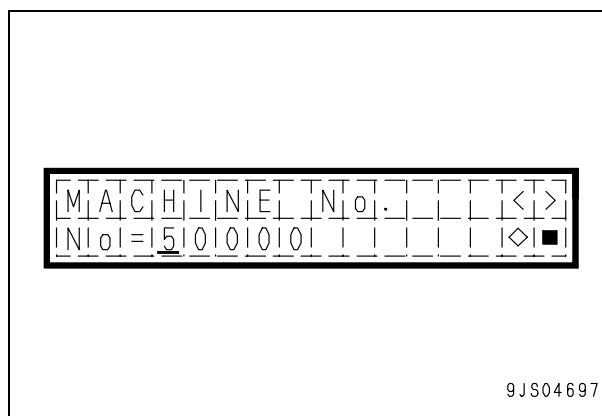

Fuse box: FS2

Type of power supply (Power source)	Fuse No.	Fuse capacity	Destination of power (*)
Accessory power supply (Slow blow fuse [80A])	1	20 A	Air conditioner blower
	2	5 A	Air conditioner compressor
	3	20 A	Beacon Working lamp (Front: For addition) Rotary lamp
	4	20 A	Glass heater
	5	10 A	Load meter, air cleaner clogging relay
	6	20 A	Key ON power for optional device
	7	10 A	DC converter
	8	10 A	Parking brake Horn
	9	10 A	Air suspension seat
	10	10 A	Small lamp (right)
	11	10 A	Small lamp (left)
	12	10 A	Working lamp (front)
	13	10 A	Working lamp (rear)
ACC signal (ACC switch)	14	10 A	Machine monitor (Starting switch ACC signal) Backup lamp Backup alarm
	15	5 A	Engine controller (Starting switch ACC signal)

*: Optional devices are included.
Devices which are not set may be included.

Location

- Inside of cover (1) at rear of console in cab

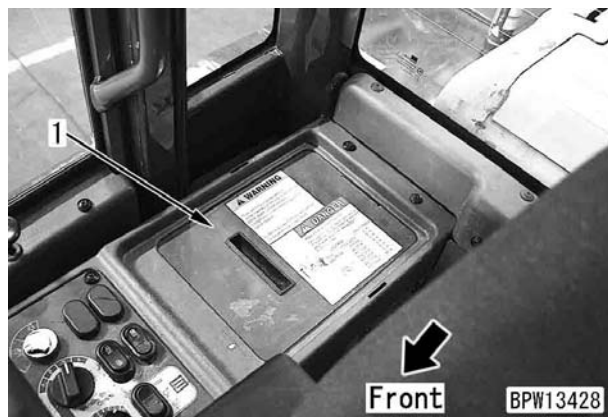

Fuse No.

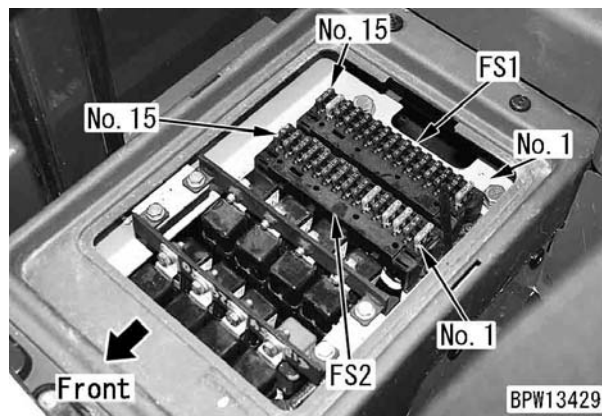

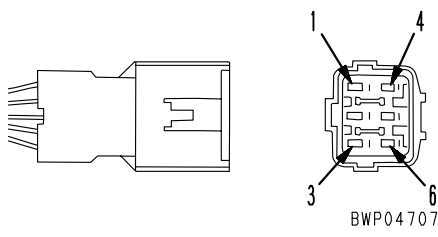
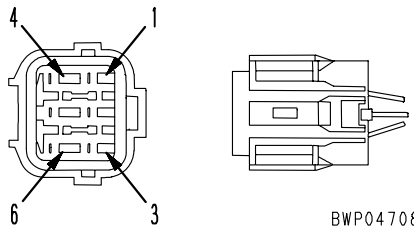
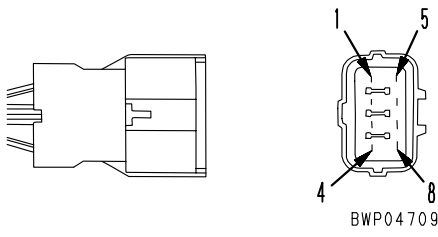
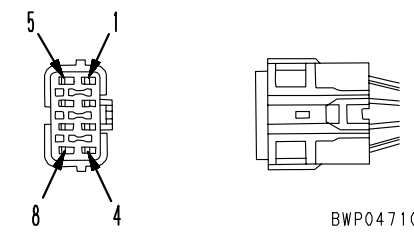
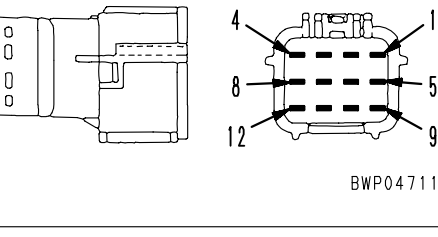
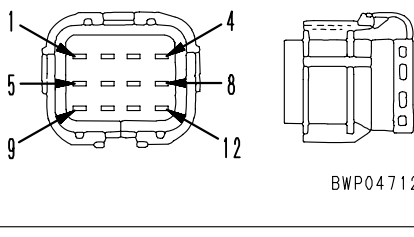
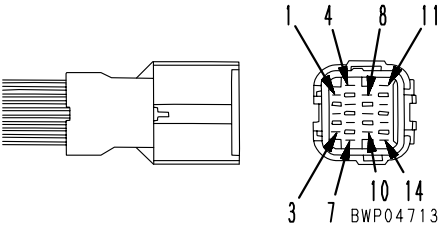
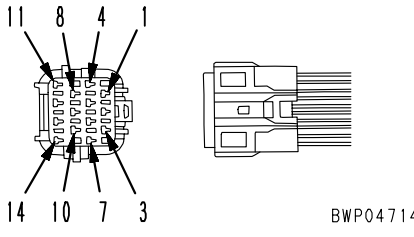
No. of pins	SWP type connector		
	Male (female housing)	Female (male housing)	T-adapter Part No.
6	 <p>BWP04707</p>	 <p>BWP04708</p>	799-601-7050
	Part No. : 08055-10681	Part No. : 08055-10691	
8	 <p>BWP04709</p>	 <p>BWP04710</p>	799-601-7060
	Part No. : 08055-10881	Part No. : 08055-10891	
12	 <p>BWP04711</p>	 <p>BWP04712</p>	799-601-7310
	Part No. : 08055-11281	Part No. : 08055-11291	
14	 <p>BWP04713</p>	 <p>BWP04714</p>	799-601-7070
	Part No. : 08055-11481	Part No. : 08055-11491	

9JS04891

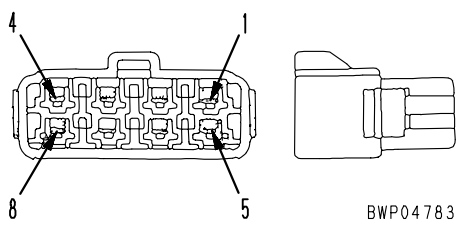
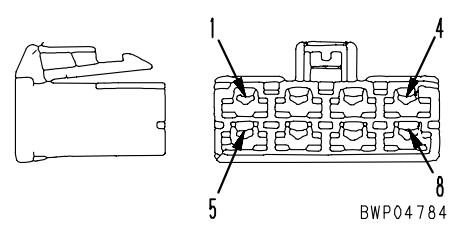
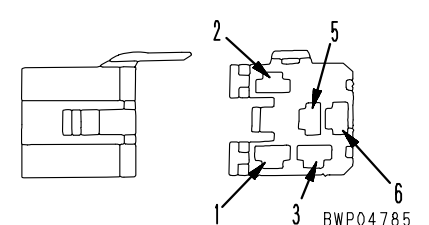
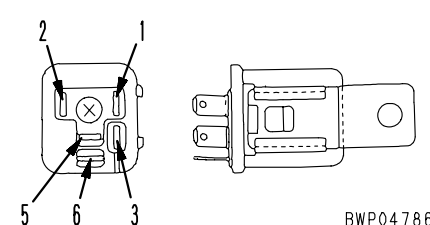
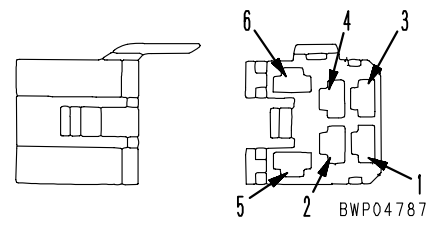
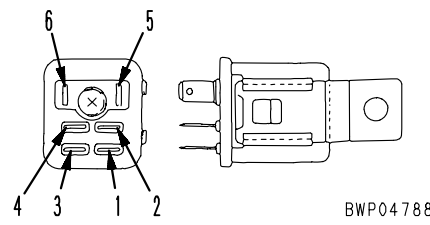
No. of pins	KES1 (Automobile) connector		
	Male (female housing)	Female (male housing)	T-adapter Part No.
8	 <p>BWP04783</p>	 <p>BWP04784</p>	—
	Part No. :08027-10810 (Natural color) 08027-10820 (Black)	Part No. :08027-10860 (Natural color) 08027-10870 (Black)	
No. of pins	Connector for relay (Socket type)		
	Male (female housing)	Female (male housing)	T-adapter Part No.
5	 <p>BWP04785</p>	 <p>BWP04786</p>	799-601-7360
	—	—	
6	 <p>BWP04787</p>	 <p>BWP04788</p>	799-601-7370
	—	—	

9JS04902

[The pin No. is also marked on the connector (electric wire insertion end)]			
No. of pins	DRC26 Series connector		
	Male pin (female housing)	Female pin (male housing)	T-adapter Part No.
60 -05※	<p style="text-align: center;">Key groove (05)</p> <p style="text-align: center;">BJD14063</p>	<p style="text-align: center;">Key (5)</p> <p style="text-align: center;">BJD14064</p>	799-601-4220 (Kit:799-601-4101)
	-	Part No. 08194-04104	
	※-05:Key position		
60 -06※	<p style="text-align: center;">Key groove (06)</p>	<p style="text-align: center;">Key (6)</p>	Socket Part No. 799-601-4390
	-	-	
	※-06:Key position		

BJH13185

Related circuit diagram

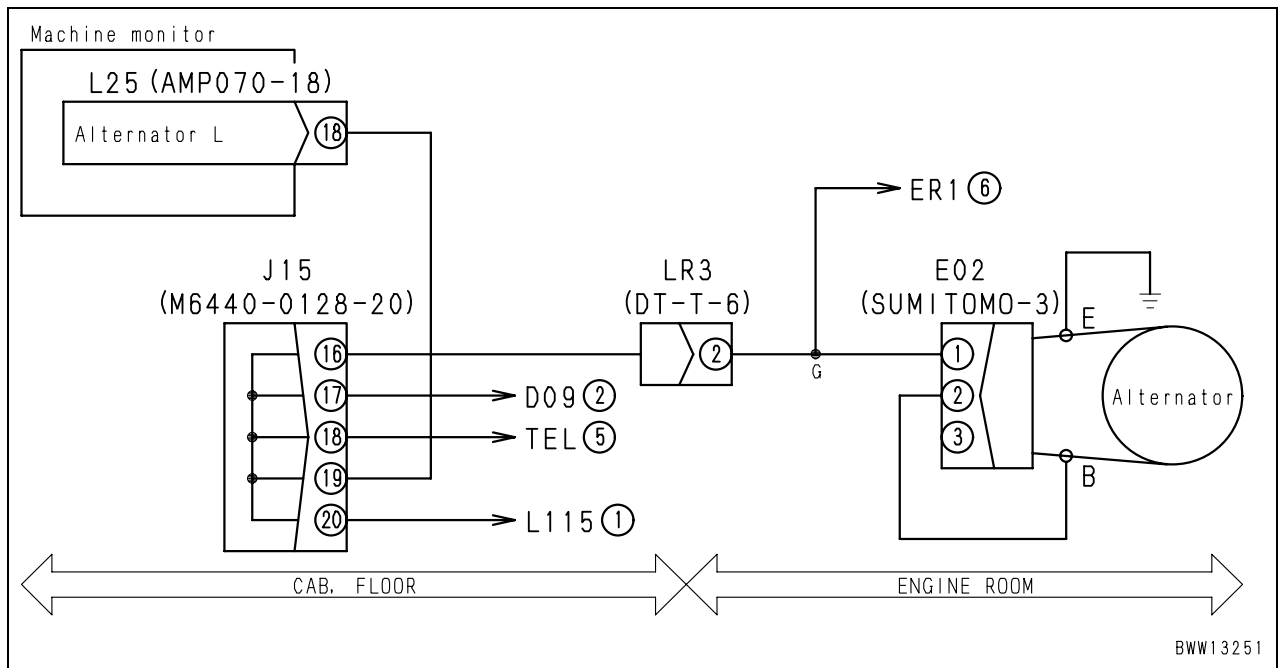

BWW13251

Blank for technical reason

CLICK HERE TO **DOWNLOAD** THE COMPLETE MANUAL

- Thank you very much for reading the preview of the manual.
- You can download the complete manual from: www.heydownloads.com by clicking the link below



- Please note: If there is no response to CLICKING the link, please download this PDF first and then click on it.

CLICK HERE TO **DOWNLOAD** THE COMPLETE MANUAL

Possible causes and standard value in normal state	Causes		Standard value in normal state/Remarks on troubleshooting		
	5	Defective engine controller		★ Prepare with starting switch OFF, then carry out troubleshooting without turning starting switch ON.	
EC1 (male)				Coolant temperature	Resistance
Between (15) and (38)				0°C	30 – 37 kΩ
				25°C	9.3 – 10.7 kΩ
				50°C	3.2 – 3.8 kΩ
				80°C	1.0 – 1.3 kΩ
95°C	700 – 800 Ω				
Between (15) and ground	All range	Min. 100 kΩ			

Related circuit diagram

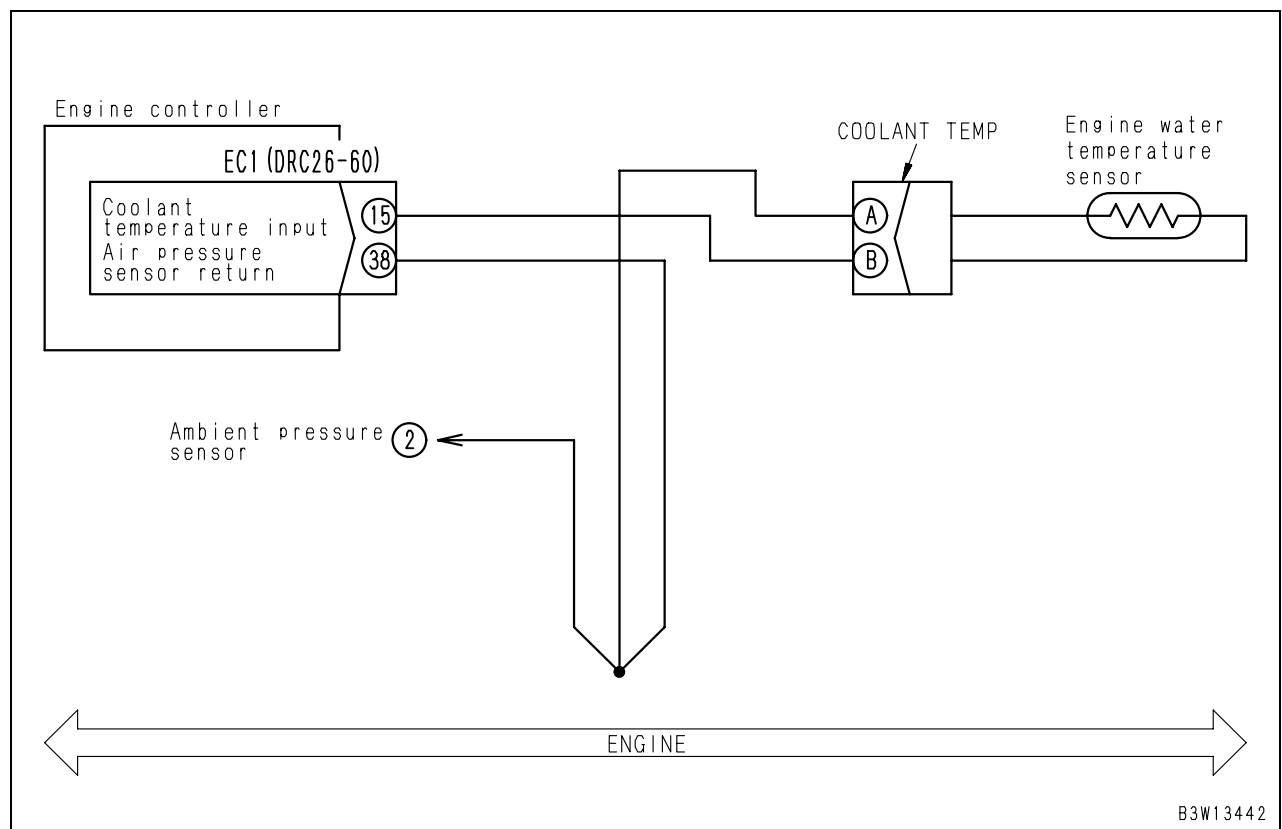

Related circuit diagram

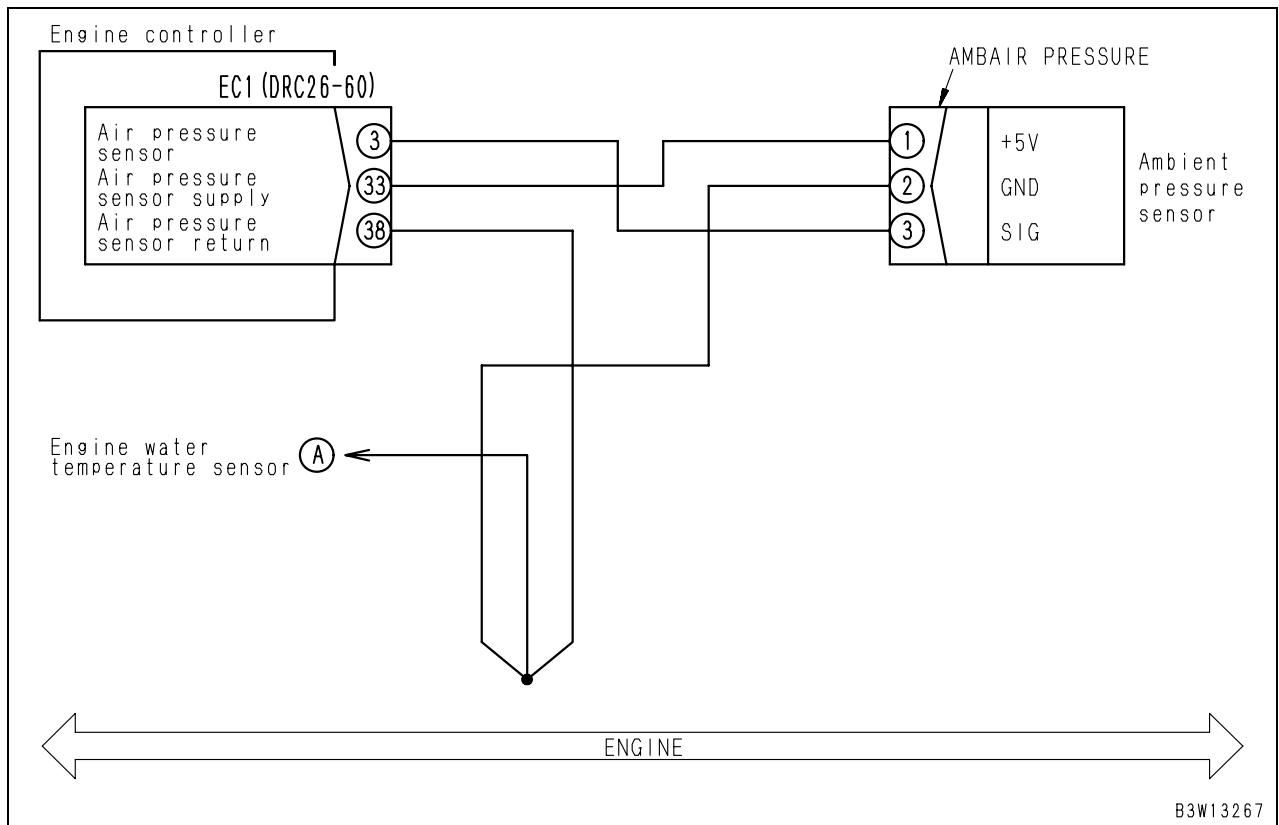

Related circuit diagram

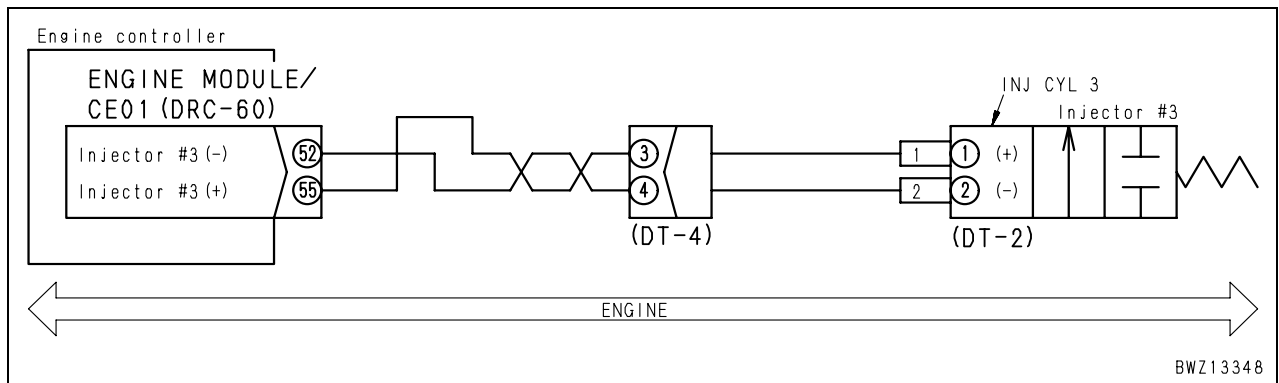

Related circuit diagram

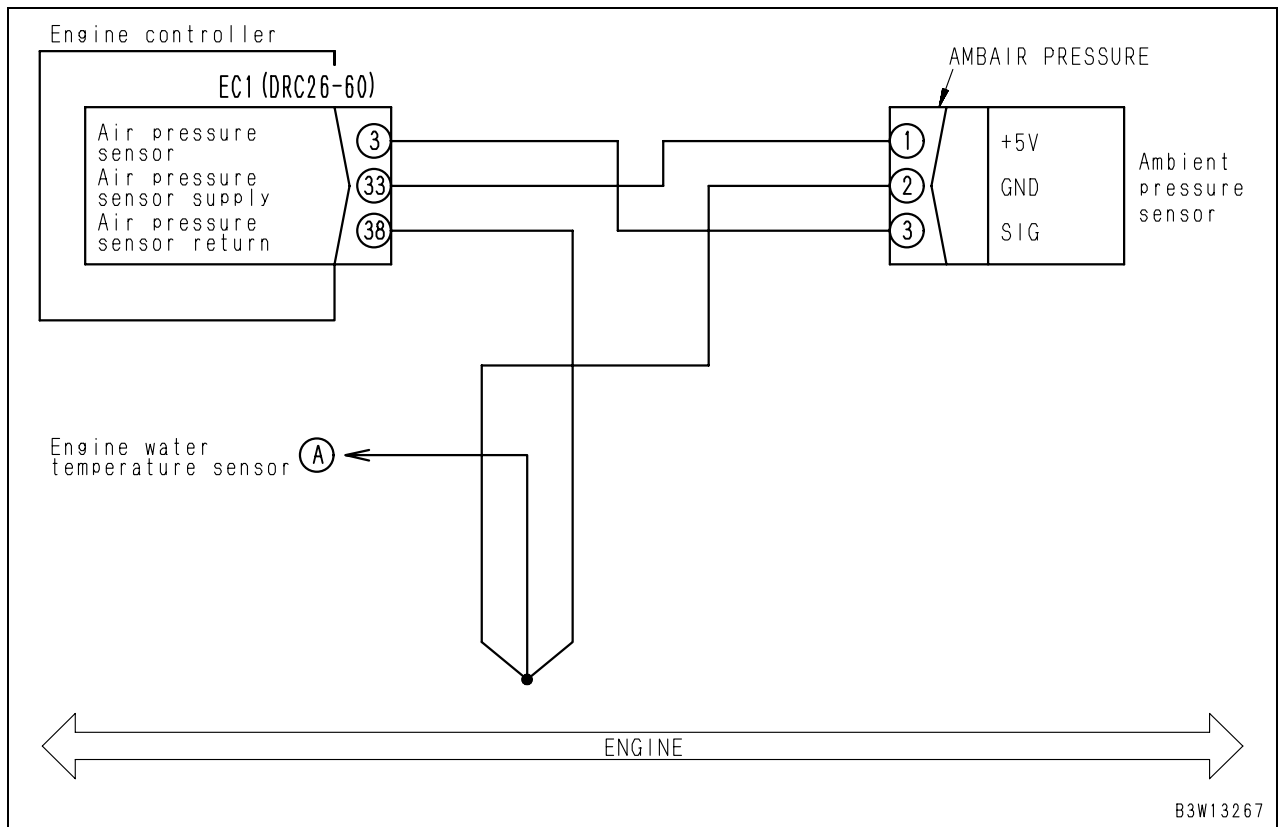

Blank for technical reason

Blank for technical reason

Failure code [CA757] All continuous data lost error

Action code	Failure code	Trouble	All continuous data lost error (Engine controller system)
E03	CA757		
Contents of trouble	<ul style="list-style-type: none"> All data in engine controller are lost. 		
Action of controller	<ul style="list-style-type: none"> Turns the centralized warning lamp and alarm buzzer ON. 		
Problem that appears on machine	<ul style="list-style-type: none"> Engine stops and sometimes cannot be started. The monitoring function of the machine monitor (engine controller system) sometimes fail to work normally. 		
Related information	<ul style="list-style-type: none"> Method of reproducing failure code: Turn the starting switch ON. 		

	Causes		Standard value in normal state/Remarks on troubleshooting		
	Possible causes and standard value in normal state	1	Defect in related system	If another code is displayed, carry out troubleshooting for it.	
2		Loose, corroded battery terminal	Inspect battery terminal directly for loose and corrosion.		
3		Defective battery voltage	★ Prepare with starting switch OFF, then carry out troubleshooting with starting switch OFF and START.		
			Battery (1 piece)	Starting switch	Voltage
			Between (+) – (–) terminals	OFF	Min. 12 V
START		Min. 6.2 V			
4		Defective fuse No. 4 of fuse box FS1	If the fuse is broken, the circuit probably has a grounding fault, etc.		
5		Defective engine control cut-out relay (L107) (Internal disconnection or short circuit)	★ Prepare with starting switch OFF, then carry out troubleshooting without turning starting switch ON.		
			L107 (male)	Resistance	
			Between (1) and (2)	200 – 400 Ω	
			★ Prepare with starting switch OFF, then turn starting switch ON and carry out troubleshooting.		
When engine control cut-out relay (L107) is replaced with a relay of the same type, if the condition becomes normal, the engine control cut-out relay (L107) is defective.					
6		Defective engine control cut-out relay (L108) (Internal disconnection or short circuit)	★ Prepare with starting switch OFF, then carry out troubleshooting without turning starting switch ON.		
	L108 (male)		Resistance		
	Between (1) and (2)		200 – 400 Ω		
	★ Prepare with starting switch OFF, then turn starting switch ON and carry out troubleshooting.				
When engine control cut-out relay (L108) is replaced with a relay of the same type, if the condition becomes normal, the engine control cut-out relay (L108) is defective.					
7	Disconnection in wiring harness (Disconnection or defective contact in connector)	★ Prepare with starting switch OFF, then carry out troubleshooting without turning starting switch ON.			
		Wiring harness between fuse No. 4 of fuse box FS1 – L107, L108 (female) (3)	Resistance	Max. 10Ω	
		Wiring harness between L107 (female) (5), L108 (female) (5) – EC3 (female) (3), (4)	Resistance	Max. 10Ω	
		Wiring harness between EC3 (female) (1), (2) – ground	Resistance	Max. 10Ω	

Related circuit diagram

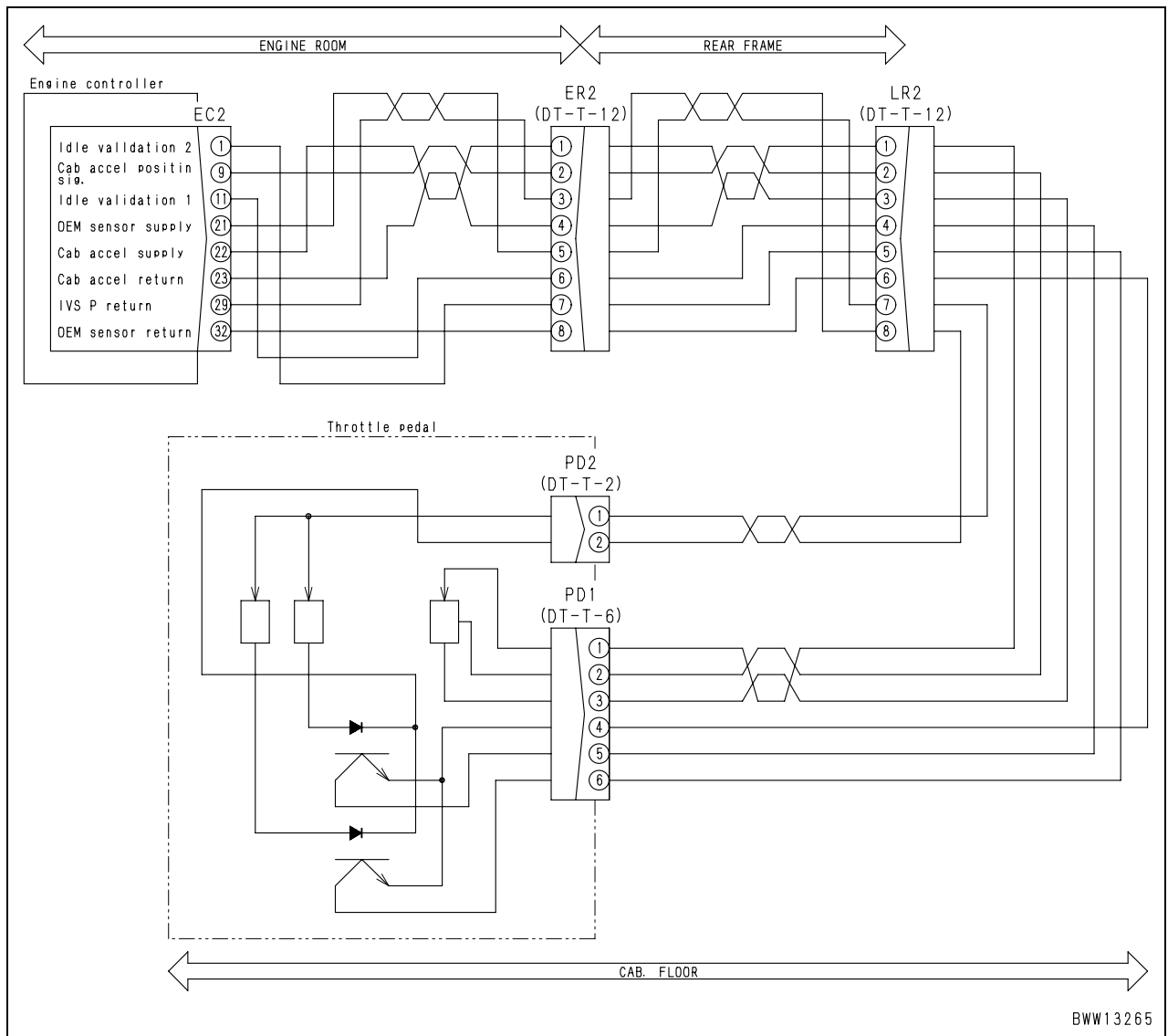

Related circuit diagram

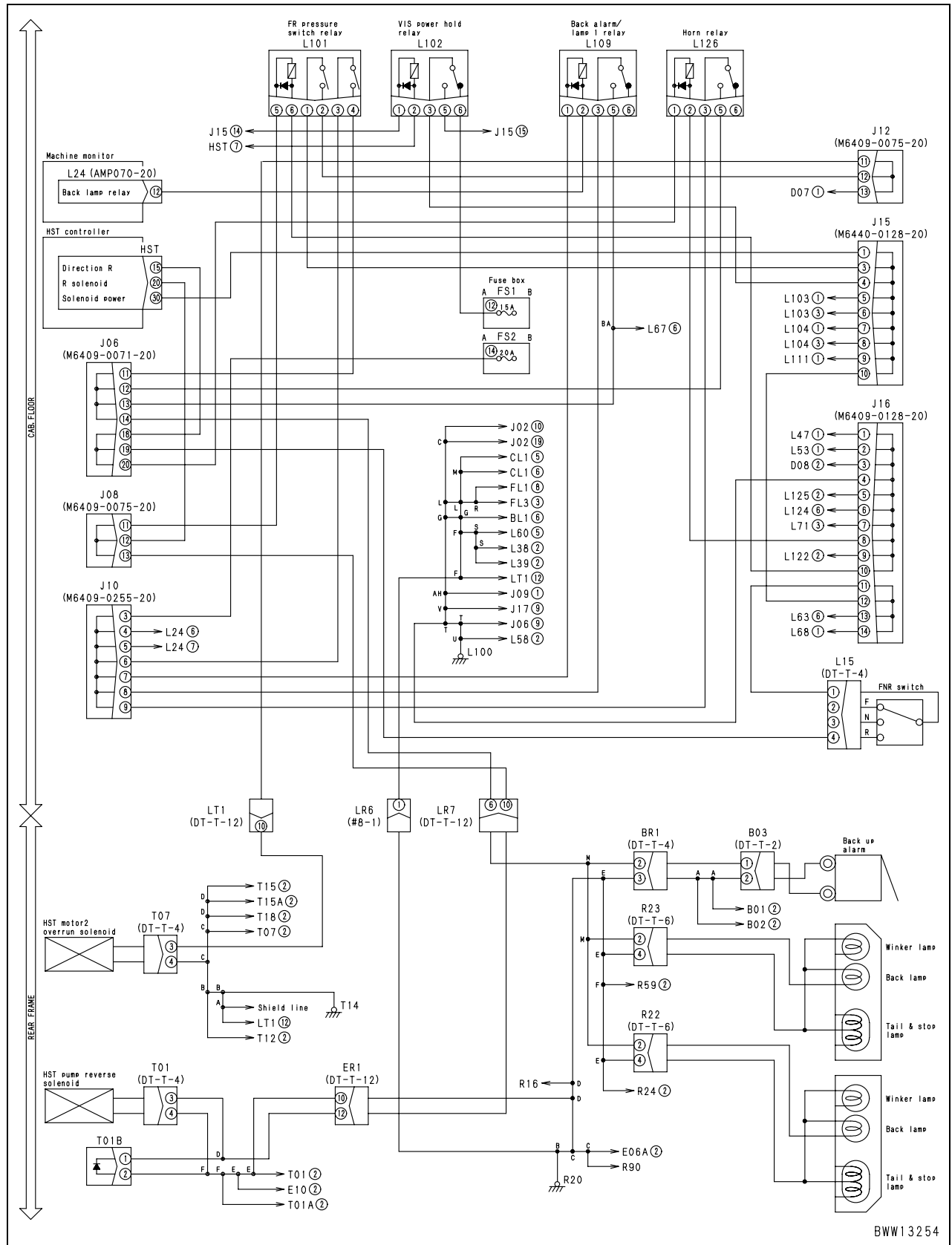

BWW13254

Related circuit diagram

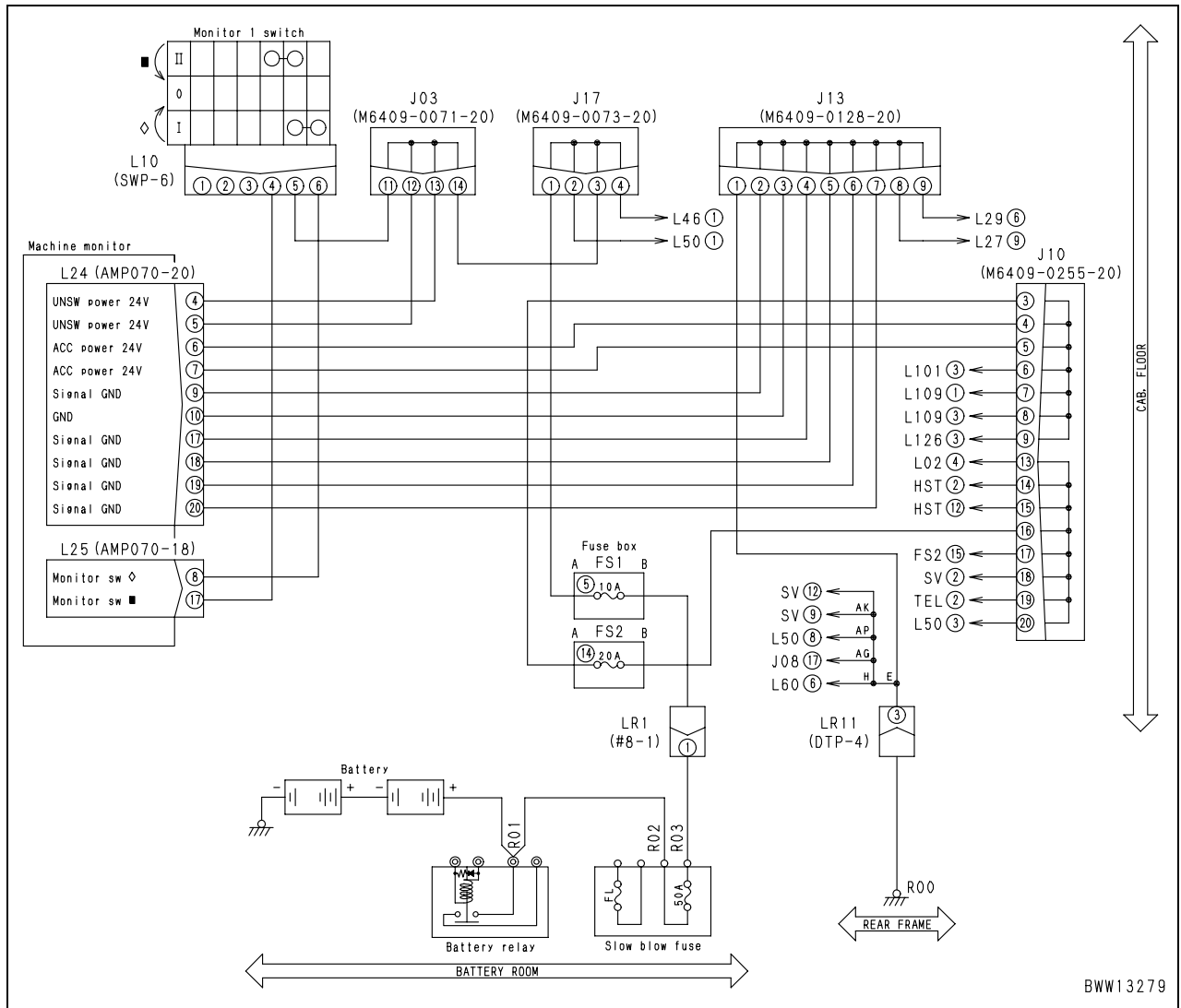

BWW13279

Related circuit diagram

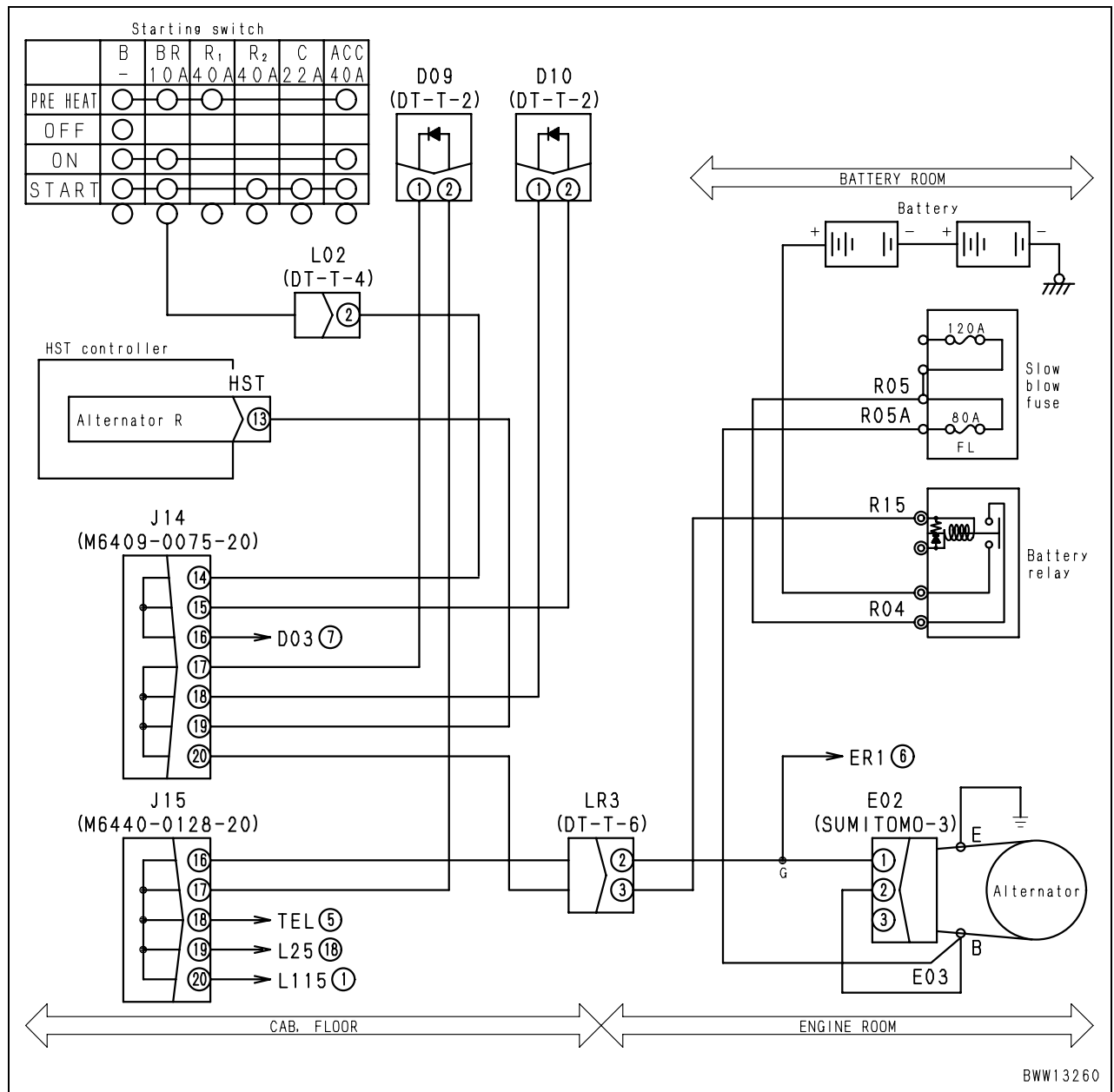

Related circuit diagram

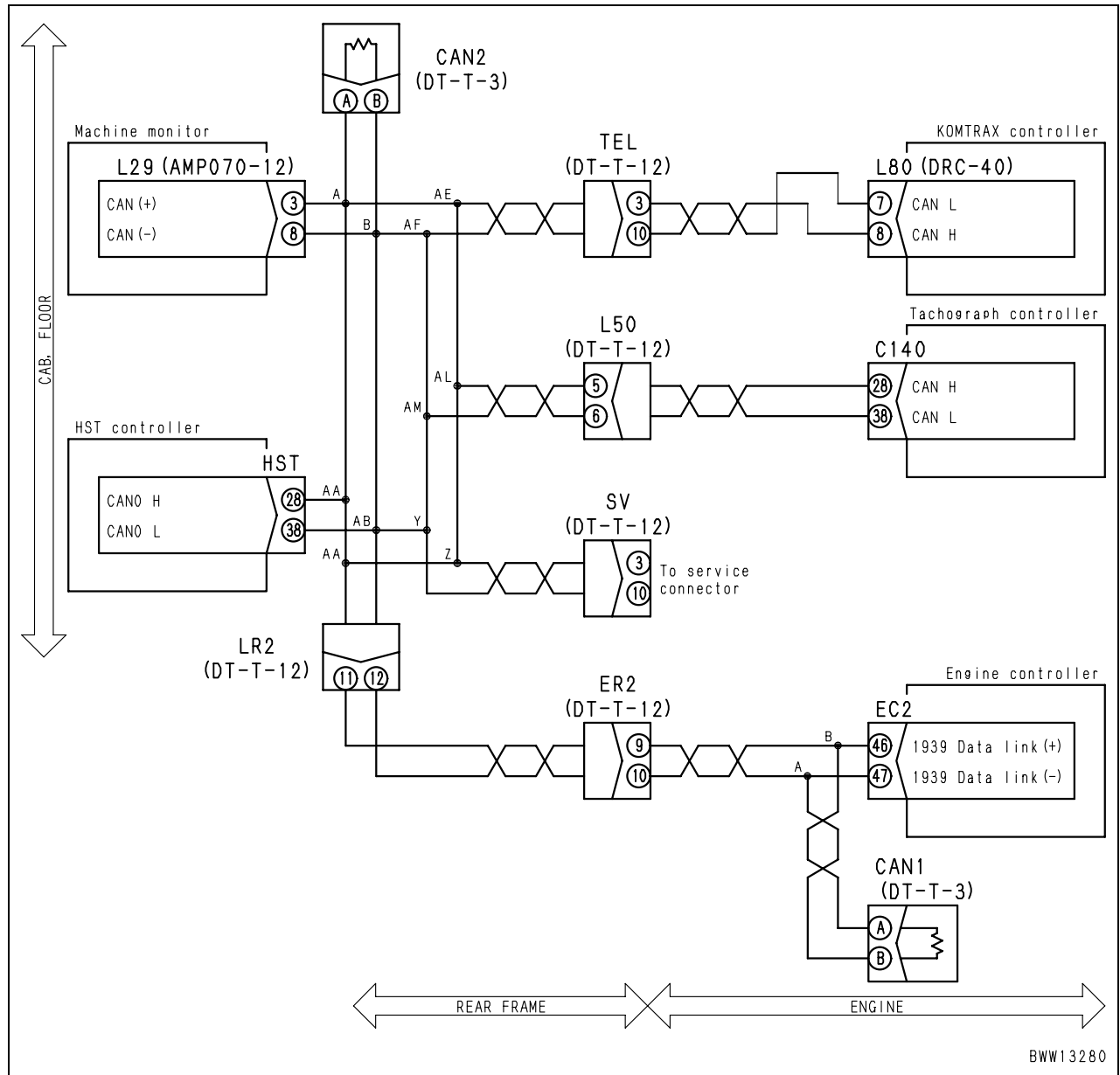

Possible causes and standard value in normal state	Causes		Standard value in normal state/Remarks on troubleshooting	
	e	Defective engine controller	★ Prepare with starting switch OFF, then turn starting switch ON and carry out troubleshooting.	
EC2			Voltage	
Between (33) – ground			Max. 1 V	
Between (39) – ground			20 – 30 V	
EC3			Voltage	
Between (3), (4) – ground			20 – 30 V	
		Between (1), (2) – ground		Max. 1 V

Related circuit diagram (When engine controller power supply circuit is defective)

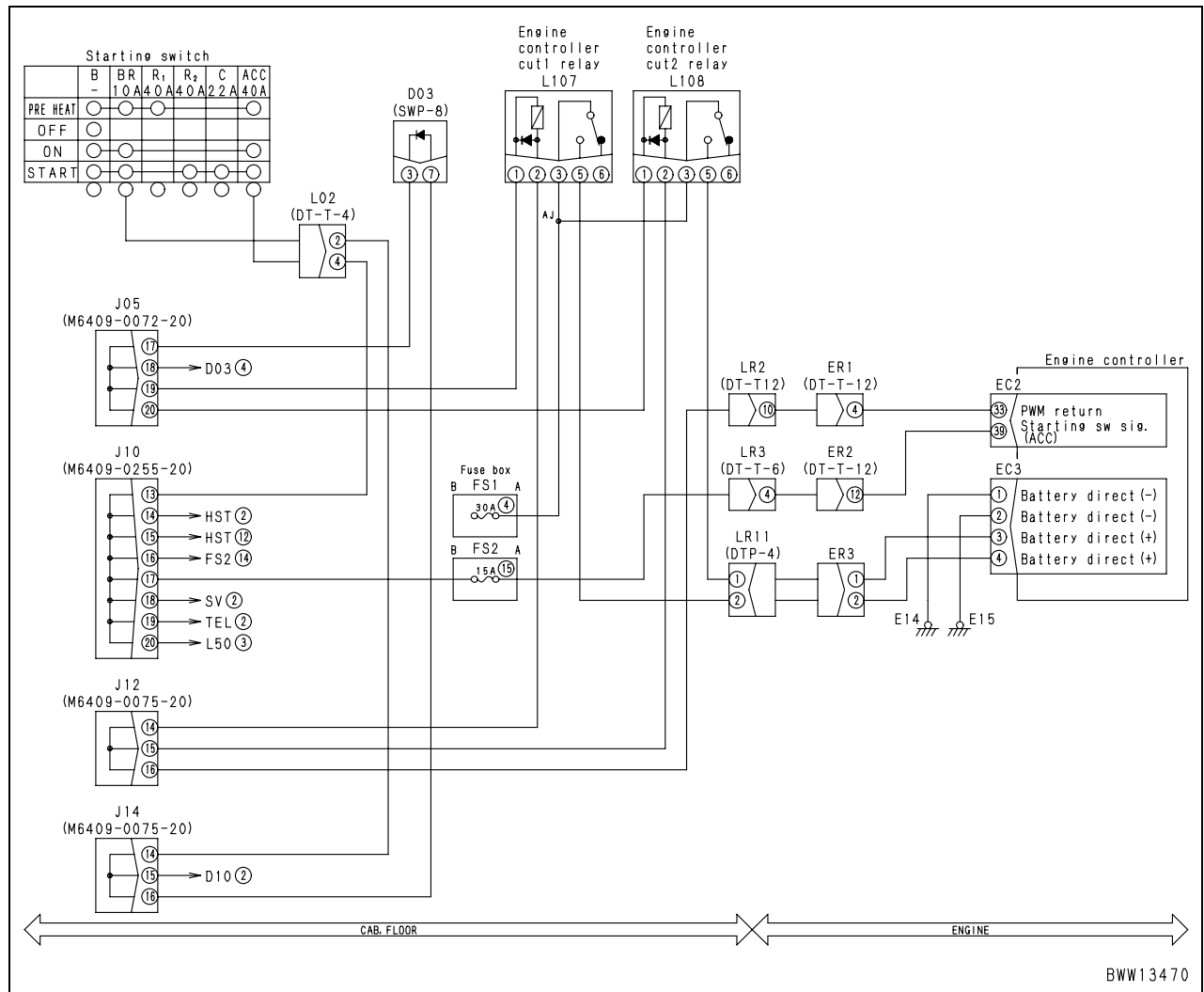

Related circuit diagram

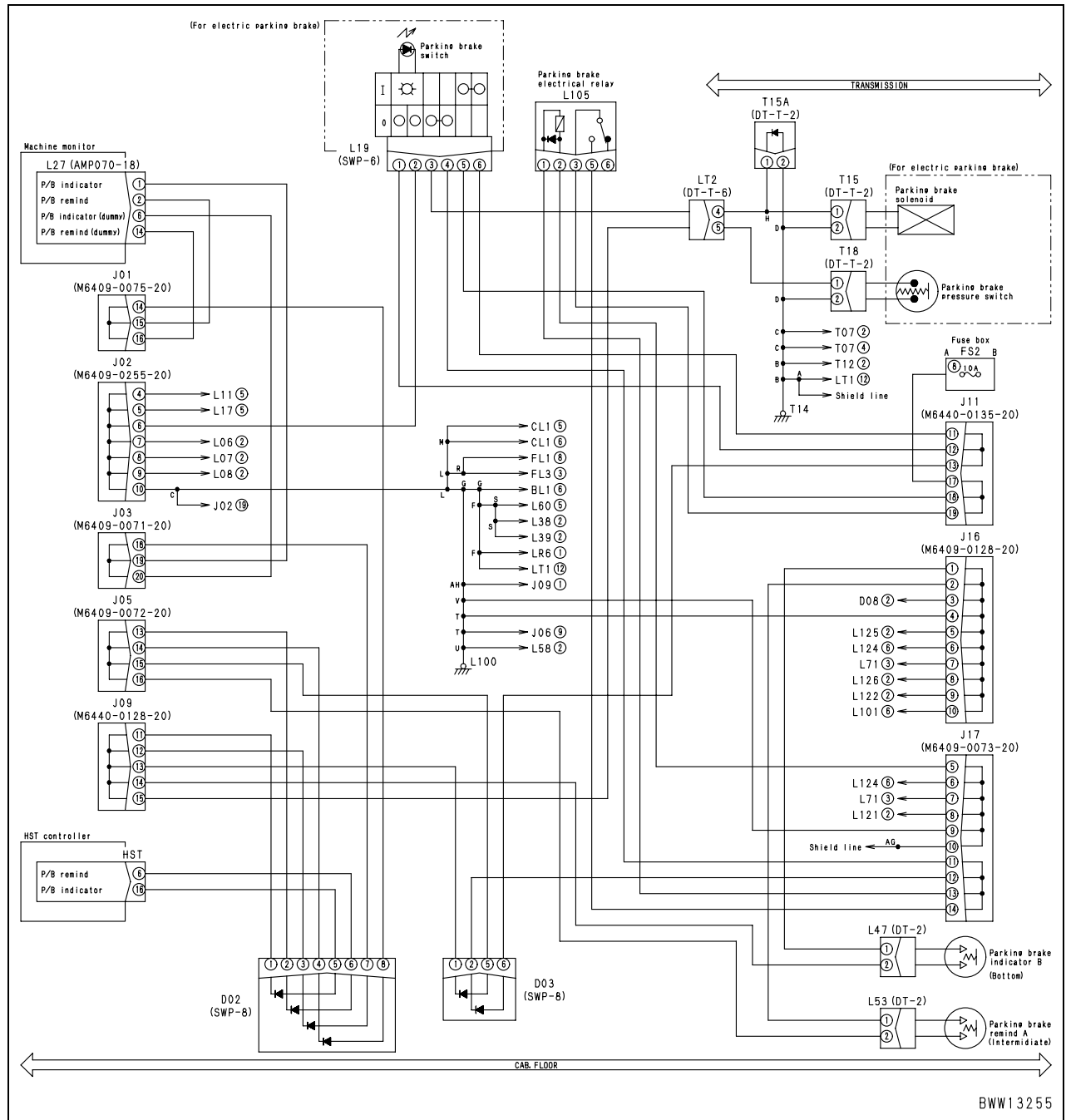

Related circuit diagram

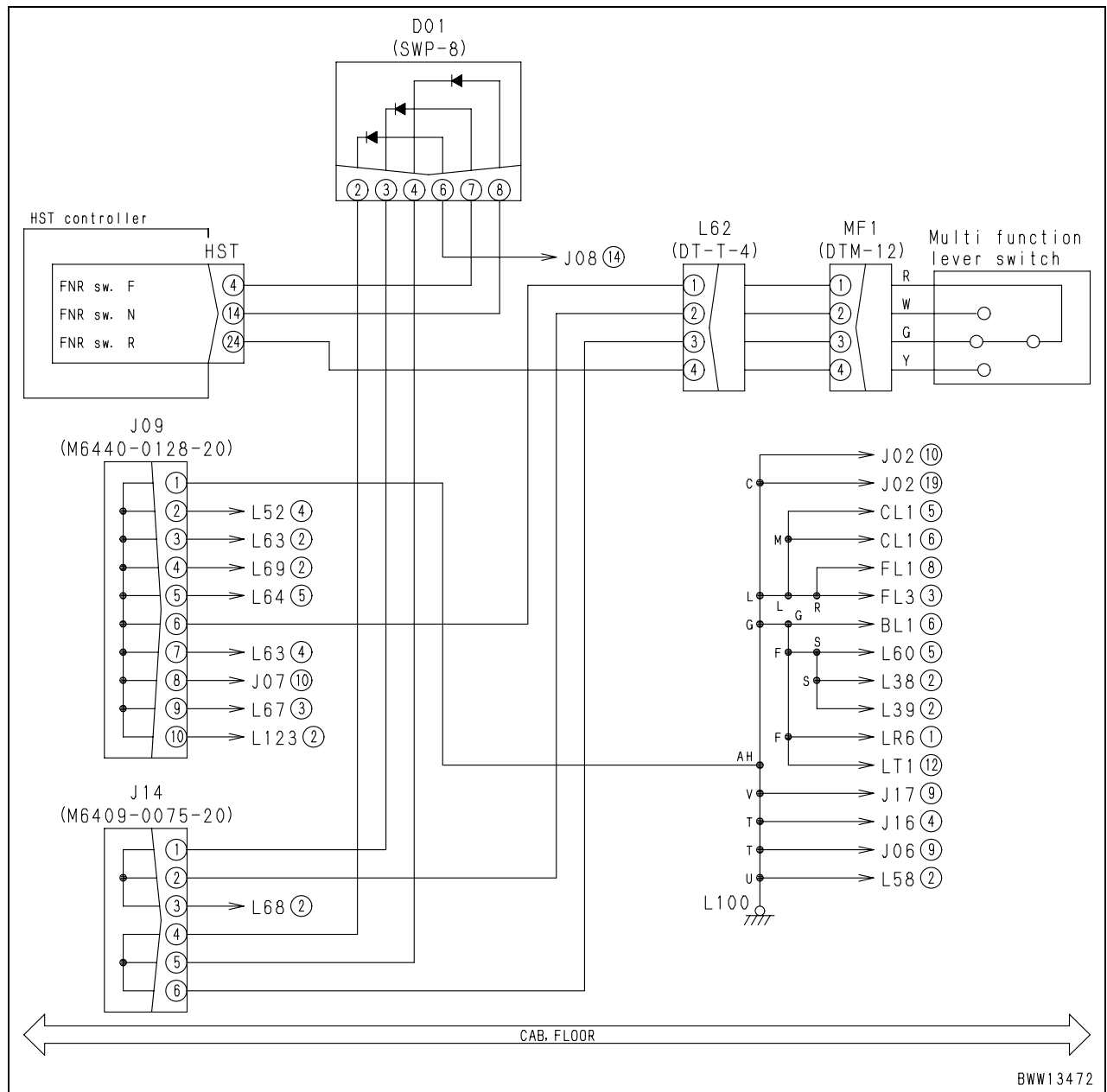

BWW13472

Failure code [DF10KA] Travel speed range selector switch: Disconnection/Ground fault

Action code	Failure code	Trouble	Travel speed range selector switch: Disconnection/Ground fault (HST controller system)
E01	DF10KA		
Contents of trouble	<ul style="list-style-type: none"> Travel speed range selector switch signal is not input because of disconnection or ground fault in travel speed range selector switch input signal system. 		
Action of controller	<ul style="list-style-type: none"> Fixes gear to speed range before error occurrence. If trouble disappears, system resets itself. 		
Problem that appears on machine	<ul style="list-style-type: none"> Once starting switch is turned OFF, gear speed is assumed to be 4th for control, regardless of selected speed range. Gear is not set in selected speed range. Indicator displays range before error occurrence. (Once starting switch is turned OFF, 4th gear is displayed) 		
Related information	<ul style="list-style-type: none"> Method of reproducing failure code: Turn starting switch ON + Operate speed range selector switch. 		

Possible causes and standard value in normal state	Causes		Standard value in normal state/Remarks on troubleshooting		
	Possible causes and standard value in normal state	1	Defective travel speed range selector switch (Internal defect)	★ Prepare with starting switch OFF, then carry out troubleshooting without turning starting switch ON.	
L03 (female)				Switch position	Resistance
Between (1) – (2)				2nd	Max. 1 Ω
				Other than above	Min. 1 MΩ
Between (1) – (3)				1st	Min. 1 MΩ
				2nd	Min. 1 MΩ
				3rd	Max. 1 Ω
				4th	Max. 1 Ω
Between (1) – (4)				4th	Max. 1 Ω
				Other than above	Min. 1 MΩ
Between (2) – (3)				– (Anytime)	Min. 1 MΩ
Between (2) – (4)				– (Anytime)	Min. 1 MΩ
Between (3) – (4)				1st	Max. 1 Ω
				2nd	Min. 1 MΩ
	3rd	Min. 1 MΩ			
	4th	Max. 1 Ω			
2	Defective travel speed range selector resistor (Internal defect)	★ Prepare with starting switch OFF, then carry out troubleshooting without turning starting switch ON.			
		L70 (male)	Resistance		
		Between (1) – (5)	100 Ω ± 1%		
		Between (2) – (6)	220 Ω ± 1%		
		Between (3) – (7)	330 Ω ± 1%		
Between (4) – (8)	470 Ω ± 1%				

Related circuit diagram

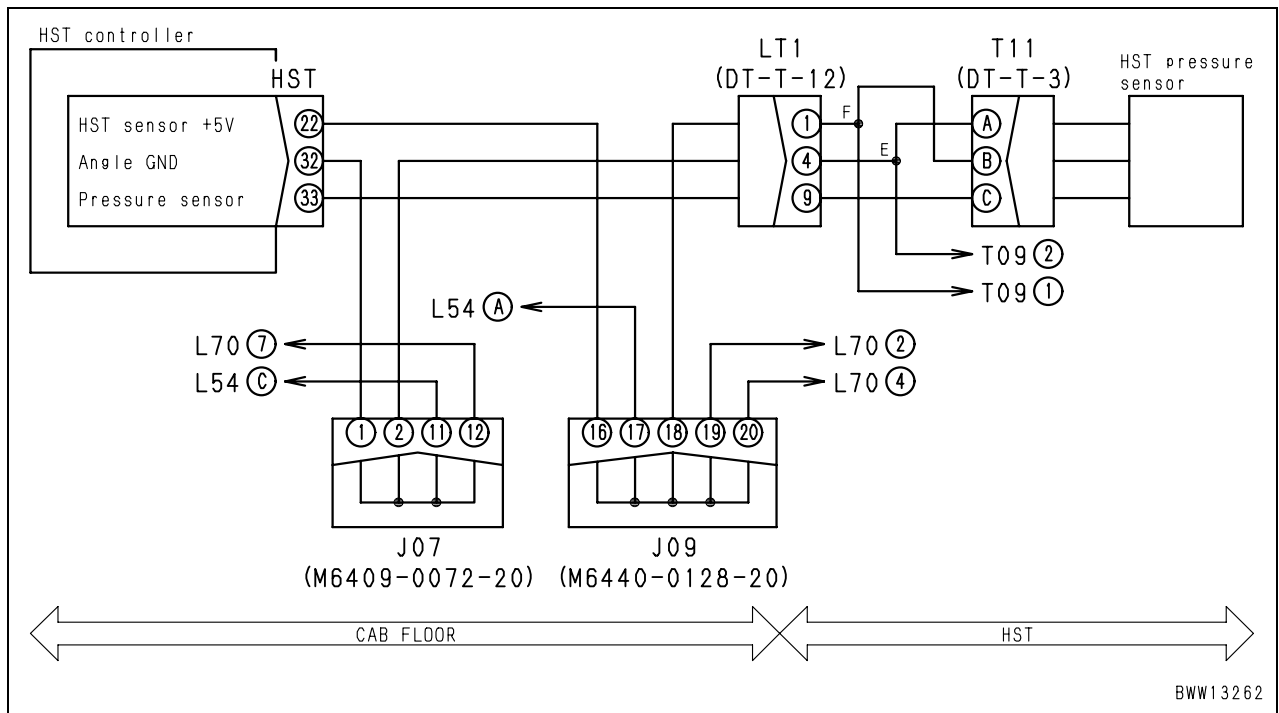

Possible causes and standard value in normal state	Causes		Standard value in normal state/Remarks on troubleshooting	
	5	Defective HST controller	★ Prepare with starting switch OFF, then start engine and carry out troubleshooting without traveling.	
HST			Voltage	
Between (22) – (32)			4.7 – 5.3 V	
Between (32) – ground			Max. 1 V	
★ Prepare with starting switch OFF, then start engine, travel at constant speed, and carry out troubleshooting.				
HST			Voltage	
Between (26) – (32)			Below 1 V – Above 4 V (Changes at regular intervals)	
Between (36) – (32)	Below 1 V – Above 4 V (Changes at regular intervals)			

Related circuit diagram

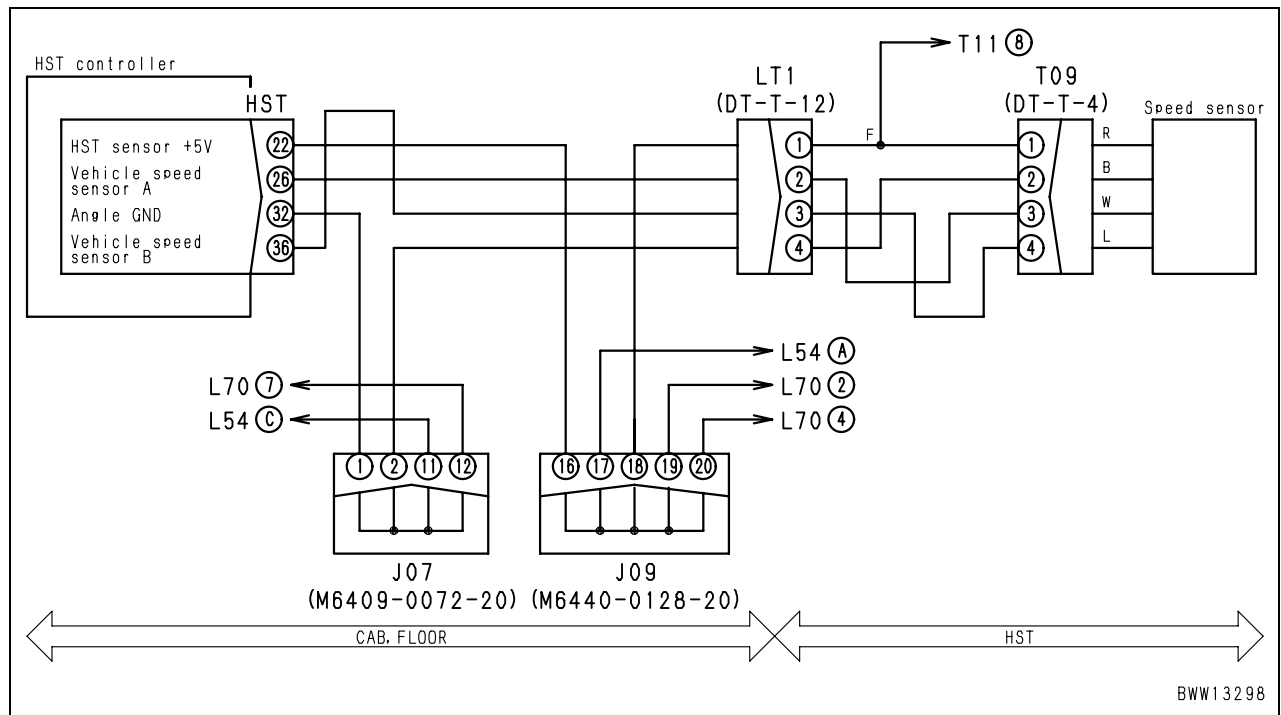

WHEEL LOADER

WA250-6

WA250PZ-6

Machine model	Serial number
WA250-6	75001 and up
WA250PZ-6	75160 and up H00051 and up

40 Troubleshooting

370 Troubleshooting by failure code (Display of code), Part 7

Failure code [DX16KA] Fan EPC solenoid: Disconnection	2
Failure code [DX16KB] Fan EPC solenoid: Ground fault.....	3
Failure code [DX16KY] Fan EPC solenoid: Hot short.....	4
Failure code [DX19KA] Motor 1 solenoid: Disconnection	6
Failure code [DX19KB] Motor 1 solenoid: Ground fault.....	8
Failure code [DX19KY] Motor 1 solenoid: Hot short	10
Failure code [DX20KA] Clutch EPC solenoid: Disconnection.....	12
Failure code [DX20KB] Clutch EPC solenoid: Ground fault.....	14
Failure code [DX20KY] Clutch EPC solenoid: Hot short.....	16
Failure code [DXH7KB] Reverse solenoid: Ground fault	18
Failure code [DXH7KZ] Reverse solenoid: Disconnection/Hot short.....	20
Failure code [DXH8KB] Forward solenoid: Ground fault	22
Failure code [DXH8KZ] Forward solenoid: Disconnection/Hot short	24
Failure code [J141N1] Steering pump: Overrun alarm.....	26
Failure code [M100N1] HST pump: Overrun alarm	26
Failure code [M400N1] Motor 1: Overrun alarm	27

Related circuit diagram

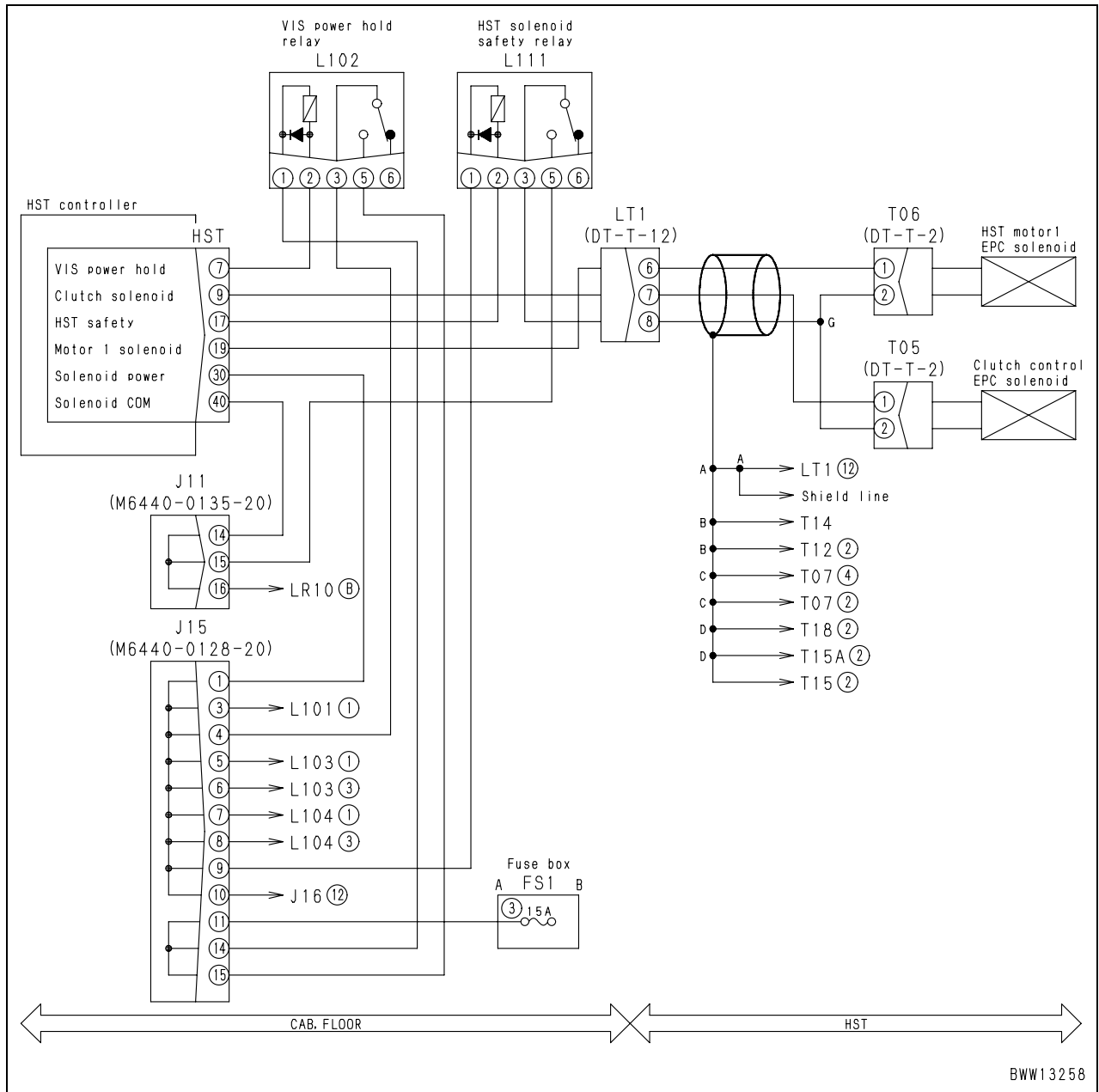

Related circuit diagram

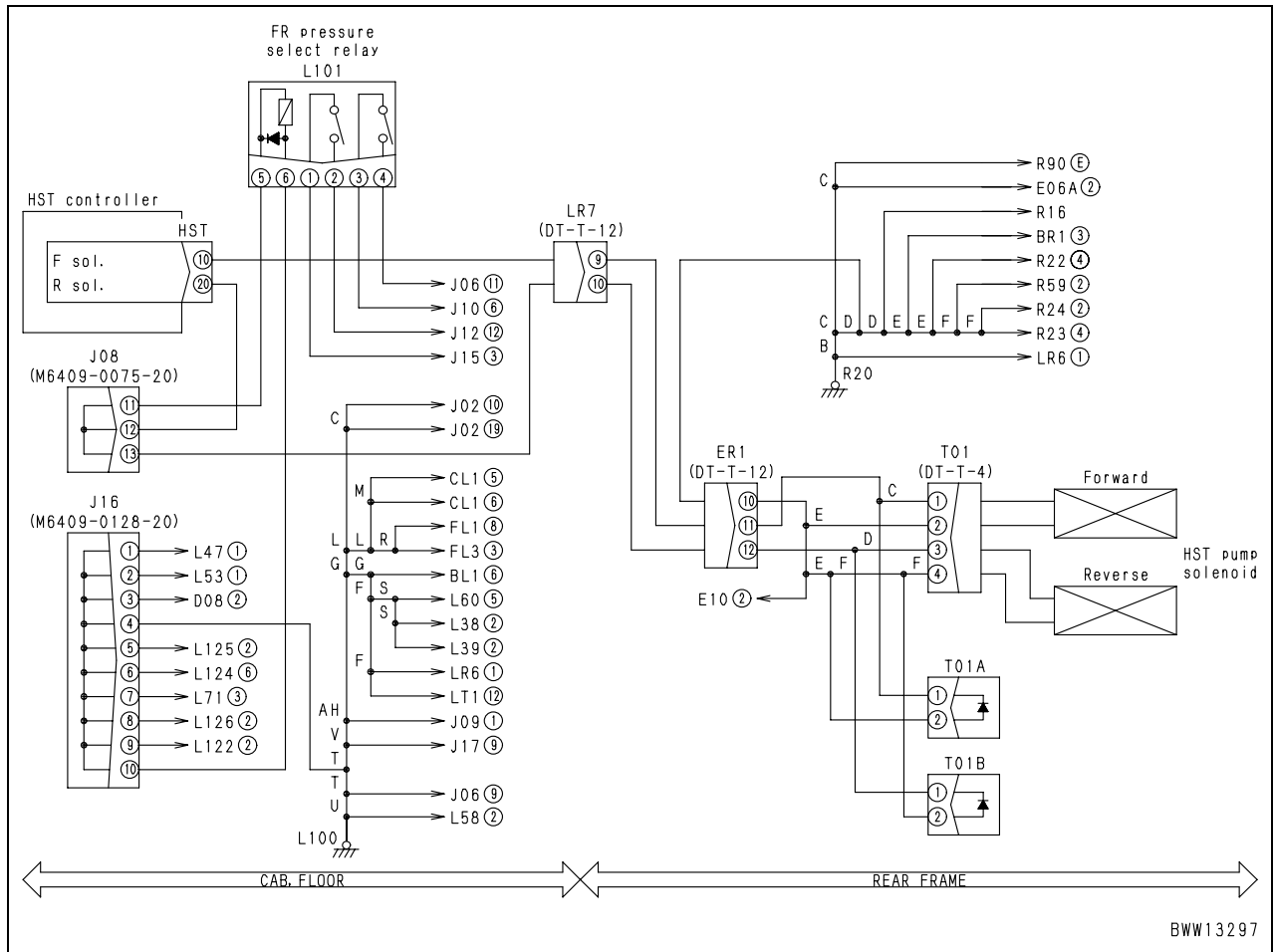

Related circuit diagram

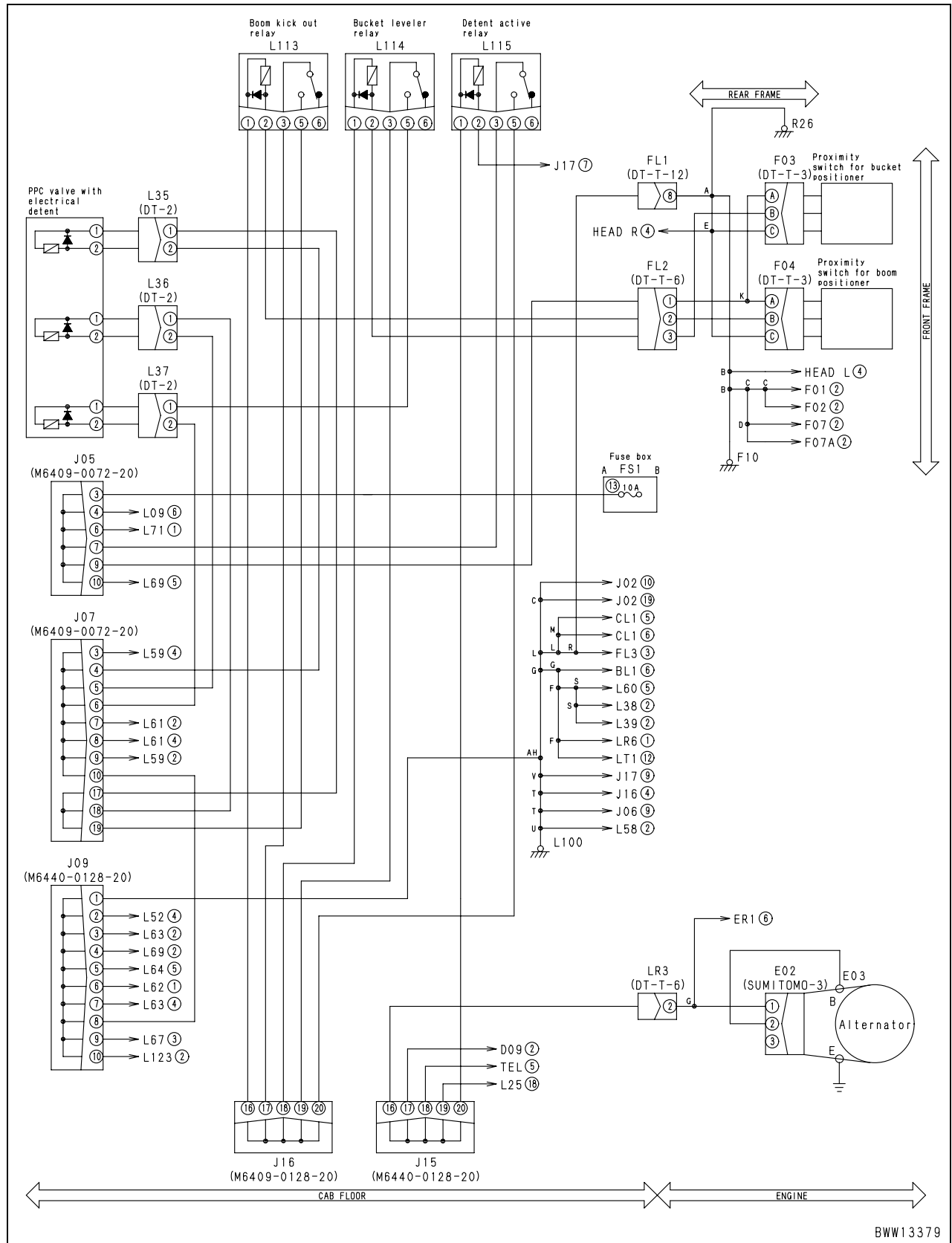

BWW13379

Related circuit diagram

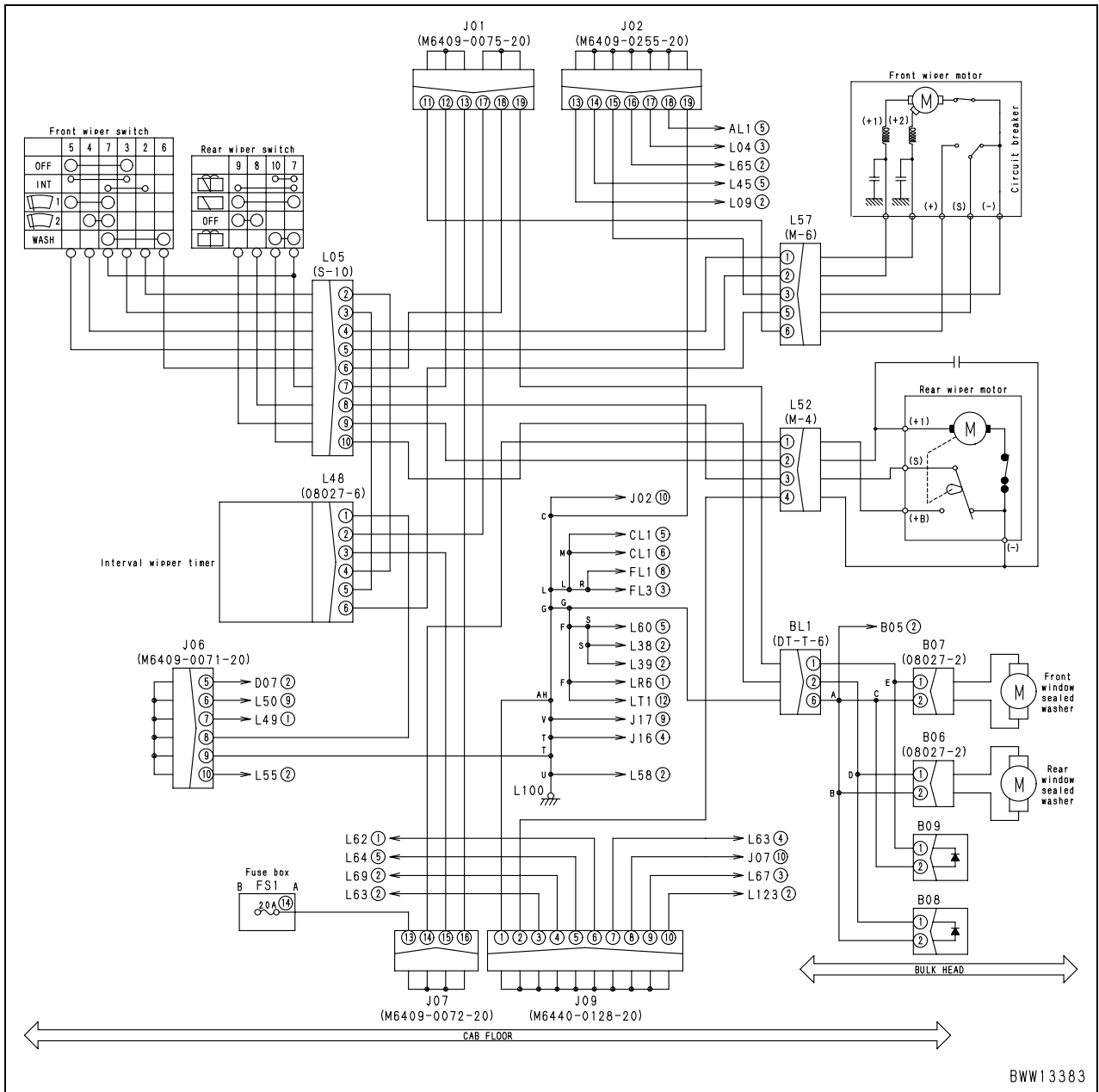

BWW13383

Related circuit diagram

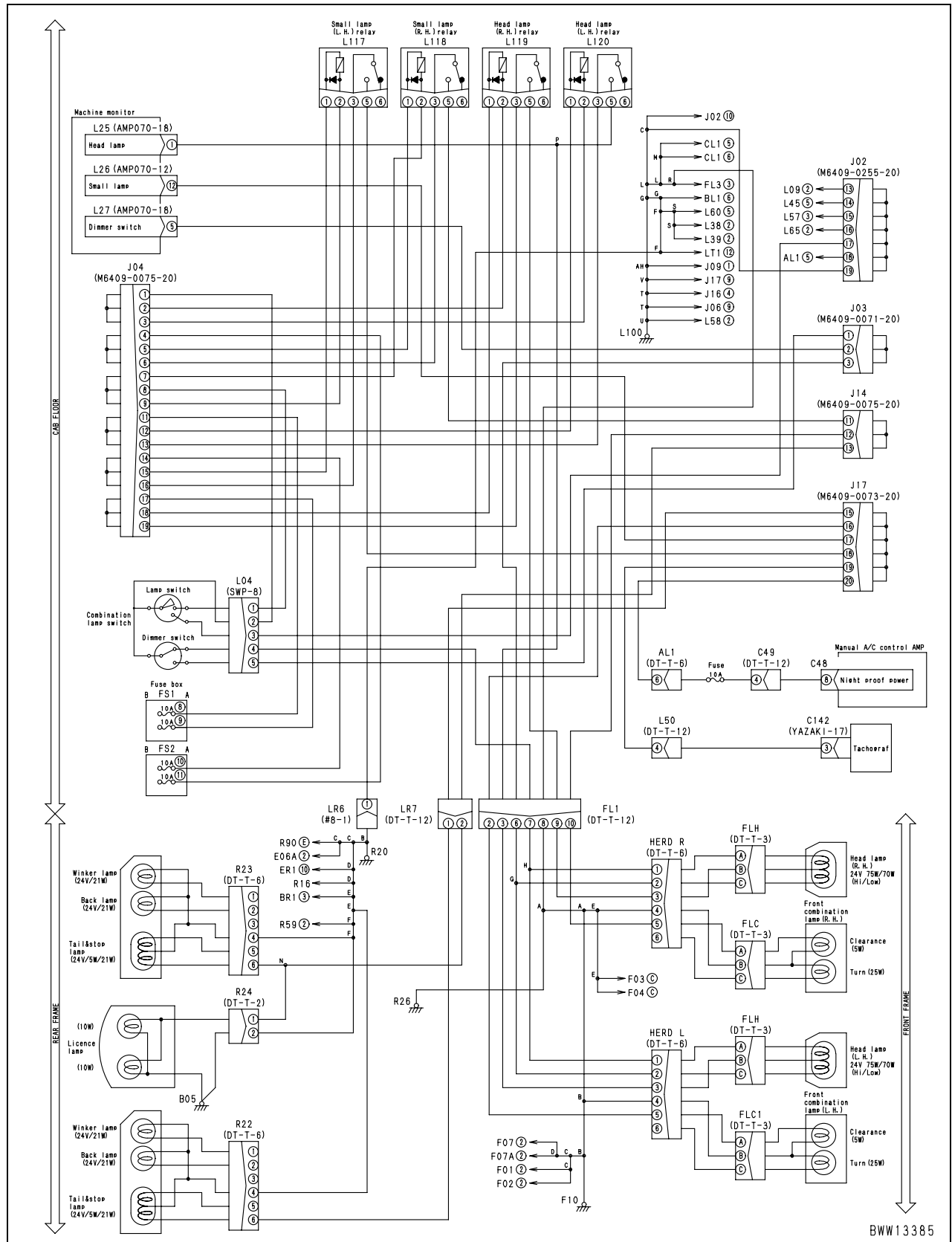

BWW13385

Blank for technical reason

Related circuit diagram

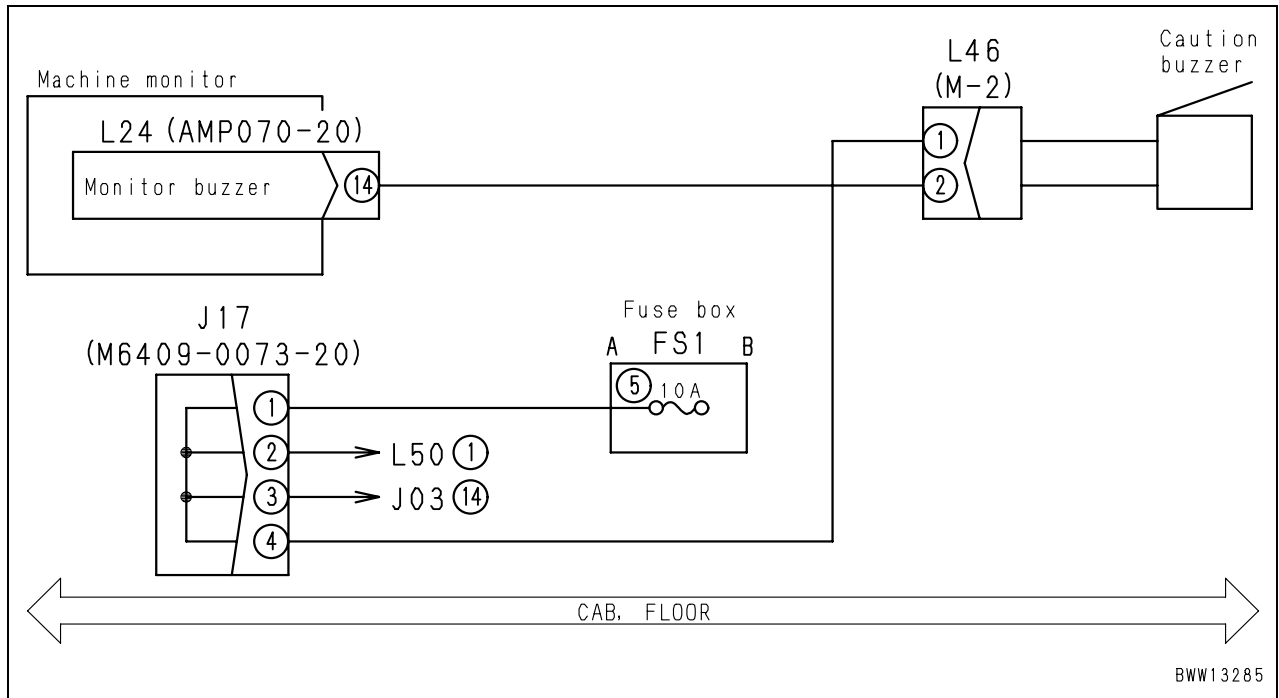

Blank for technical reason

H-11 The brake is not released or is dragged

Ask the operator about the following:

- Has the brake pedal returned completely?
- Is the parking brake released completely?

Check abnormality

- Abnormal heat of brake.
- Does the machine travel smoothly inertia on a level ground?

		Cause				
		a	b	c	d	
		Defective brake piston seal in axle	Defective operation of brake piston in axle	Defective slack adjuster	Wear or abnormality of brake lining in axle	
No.	Diagnosis	Remedy	<input type="checkbox"/>	<input type="checkbox"/>	<input type="checkbox"/>	<input type="checkbox"/>
1	The brake pedal is released, but the brake is still applied		<input type="checkbox"/>	<input type="checkbox"/>	<input type="checkbox"/>	<input type="checkbox"/>
2	When the brake pedal is released, oil is drained from the air bleeder, the circuit oil pressure drops and the brake is released		<input type="checkbox"/>	<input type="checkbox"/>	<input type="checkbox"/>	<input type="checkbox"/>
3	When the four wheels are jacked up, the axle is placed on a table, the engine is stopped, the parking brake is released and the tires are rotated by hand but a specific tire hardly rotates		<input type="checkbox"/>	<input type="checkbox"/>	<input type="checkbox"/>	<input type="checkbox"/>

WHEEL LOADER

WA250-6

WA250PZ-6

Machine model Serial number

WA250-6 75001 and up

WA250PZ-6 75160 and up
 H00051 and up

40 Troubleshooting

600 Troubleshooting of engine (S-mode)

Method of using troubleshooting charts	2
S-1 Starting performance is poor	6
S-2 Engine does not start	7
S-3 Engine does not pick up smoothly.....	10
S-4 Engine stops during operations	11
S-5 Engine does not rotate smoothly	12
S-6 Engine lacks output (or lacks power)	13
S-7 Exhaust smoke is black (incomplete combustion).....	14
S-8 Oil consumption is excessive (or exhaust smoke is blue)	15
S-9 Oil becomes contaminated quickly	16
S-10 Fuel consumption is excessive.....	17
S-11 Oil is in coolant (or coolant spurts back or coolant level goes down)	18
S-12 Oil pressure drops	19
S-13 Oil level rises (Entry of coolant or fuel).....	20
S-14 Coolant temperature becomes too high (overheating)	21
S-15 Abnormal noise is made	22
S-16 Vibration is excessive	23

S-6 Engine lacks output (or lacks power)

General causes why engine lacks output

- Insufficient intake of air
- Insufficient supply of fuel
- Defective condition of fuel injection
- Improper selection of fuel
- There is overheating
→ See “S-14 Coolant temperature becomes too high (Overheating)”
- Controller is controlling in derate mode (limiting injection rate (output) because of an error in electrical system)

		Causes														
		Clogged air cleaner element	Air leakage from air intake piping	Seized turbocharger, interference of turbocharger	Defective contact of valve and valve seat	Improper valve clearance	Worn piston ring, cylinder	Clogged air breather hole of fuel tank cap	Leaking, clogged fuel piping	Clogging of fuel filter	Stuck, seized supply pump plunger	Clogged injector, defective spray (dirt in injector)	Defective drive of injector (signal, solenoid)	Defective installation of boost pressure sensor (air leakage)	Defective boost pressure sensor, wiring harness	Clogged fuel spill piping

Questions	Confirm recent repair history															
	Degree of use of machine	Operated for long period		△			△	△			△					
Power was lost	Suddenly			○	○									○	○	○
	Gradually		○			○	○			○	○	○			○	
Non-specified fuel is being used										○	○	○				
Replacement of filters has not been carried out according to Operation and Maintenance Manual				○						○						
Oil must be added more frequently						○	○									
Dust indicator is red				○	○											
Air breather hole of fuel tank cap is clogged						○		○								
Fuel is leaking from fuel piping									○							
Output becomes insufficient after short stop of operation					○											
Color of exhaust gas is	Black				○		○									
	Blue under light load							○								
When exhaust manifold is touched immediately after starting engine, temperature of some cylinders is low												○	○			
When engine is cranked, interference sound is generated around turbocharger						○										
When engine is cranked, abnormal sound is generated around cylinder head							○									
High idle speed is too high													○			
High idle speed under no load is normal, but speed suddenly drops when load is applied								○	○	○	○					
Engine does not pick up smoothly and combustion is irregular				○	○			○	○		○					
There is hunting from engine (rotation is irregular)							○	○	○		○	○				
Blow-by gas is excessive					○		○									

Troubleshooting															Remedy				
	Inspect air cleaner directly	●																	
Inspect air intake piping directly		●																	
When boost pressure is measured, it is found to be low	●	●	●																
When compression pressure is measured, it is found to be low				●	●														
Inspect valve clearance directly					●														
Inspect fuel piping									●										
Inspect fuel filter, strainer directly										●									
Inspect spill port check valve directly																			●
Carry out troubleshooting according to “No-pressure feed by supply pump (*1)” in display of code											●								
When a cylinder is cut out for reduced cylinder mode operation, engine speed does not change												●	●						
Inspect boost pressure sensor mount directly															●				
Carry out troubleshooting according to “Abnormality in boost pressure sensor (*2)” in display of code																			●
																			●
																			●

*1: Failure codes [CA559] and [CA2249] in the display of code

*2: Failure codes [CA122] and [CA123] in the display of code

WHEEL LOADER

WA250-6

WA250PZ-6

Machine model	Serial number
WA250-6	75001 and up
WA250PZ-6	75160 and up H00051 and up

50 Disassembly and assembly

100 General information on disassembly and assembly

How to read this manual	2
Coating materials list.....	4
Special tool list	7
Sketches of special tools	11

Note: Komatsu cannot accept any responsibility for special tools manufactured according to these sketches.

H1 Push tool

9JF00893

HEAT TREATMENT ----	MATERIAL STKM13A
PART NAME PUSH TOOL	Q' TY 1
793T-422-1230	

Numerical values and units within curly brackets are for reference

H1 Push tool

9JF00894

HEAT TREATMENT ----	MATERIAL STKM13A
PART NAME PUSH TOOL	Q' TY 1
793T-423-1110	

Numerical values and units within curly brackets are for reference



13. Remove 6 high-pressure pipes (15). [*8]
★ Loosen the sleeve nut on the common rail side of each high-pressure pipe.

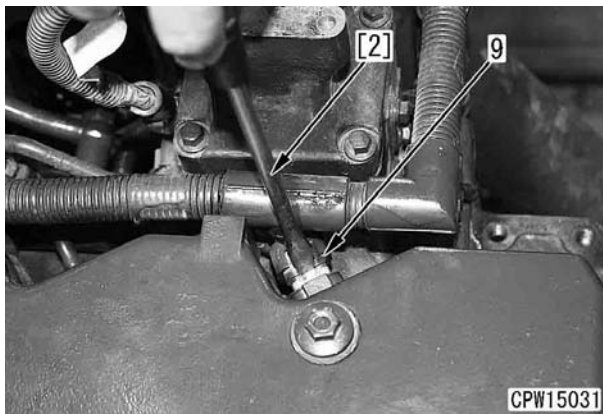
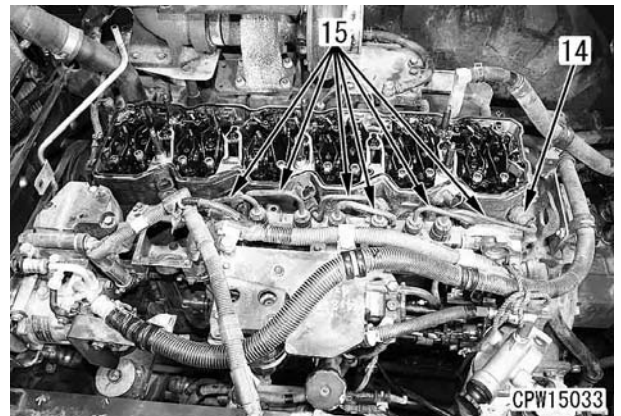

14. Position the crankshaft according to the following procedure.

- 1) Remove plug (16) under the starting motor and set tool **A4**.
- 2) Rotate the crankshaft forward (counterclockwise seeing from the flywheel side) to set marks (M1) and (M2).

Mark (M1): Top of projection of front cover
Mark (M2): A wide slit on slitted revolution sensor disc at rear of crankshaft pulley

Mark (M3): Yellow paint on vibration damper (on prolongation of wide slit (M2))

- ★ Set the projection top of mark (M1) within the wide slit (M2).
- ★ There is yellow paint mark (M3) on the prolongation of wide slit (M2).
- ★ When the marks are set as above, the piston of the No. 1 or No. 6 cylinder is 76 – 88° before the top dead center.
- ★ See Testing and adjusting, "Adjusting valve clearance".
- ★ Use tool **A4** to rotate the crankshaft.

10. Using hexagonal wrench (width across flats: 3 mm), remove blow-by duct (11). [*5]

11. Remove 6 mounting nuts (12) and cylinder head cover (13). [*6]

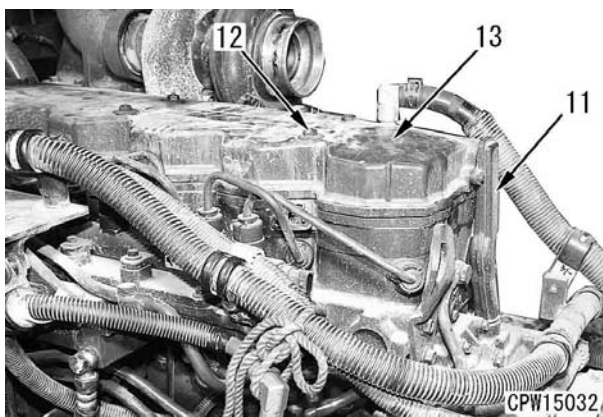

12. Remove 6 boots (14). [*7]

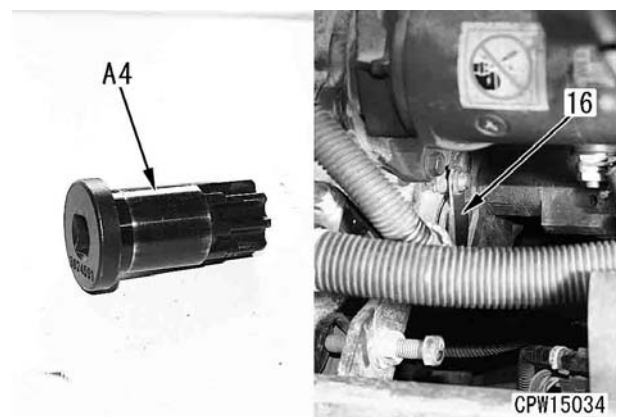

51. Remove 2 mounting bolts (59) of fuel injector assembly (57).

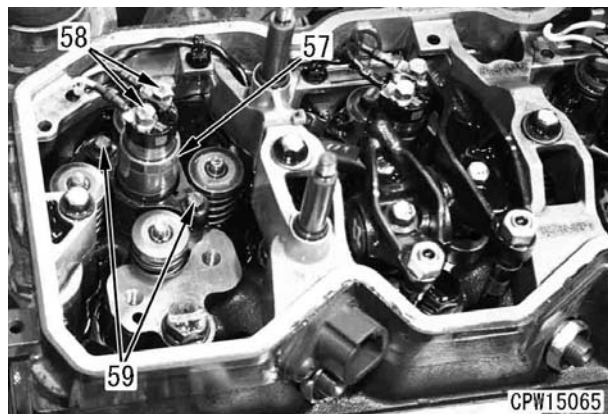

52. Using tool **A3**, remove fuel injector assembly (57).

★ Take care that dirt and foreign matter will not enter the fuel injector assembly mounting area.

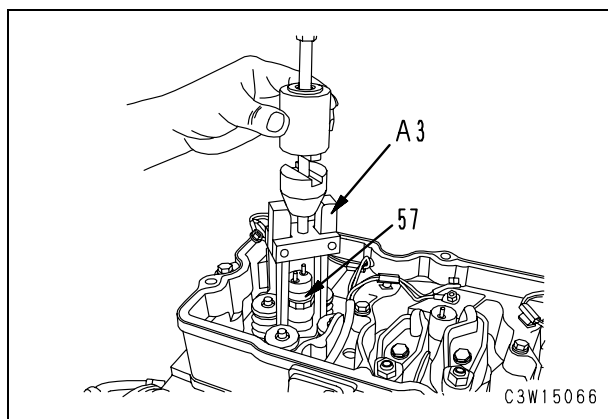

53. Remove push rods (60).
54. Remove 7 mounting bolts (61) and rocker housing (62).



55. Remove 26 mounting bolts (63) and lift off cylinder head assembly (64).

 Cylinder head assembly: **75 kg**

56. Remove cylinder head gasket (65).

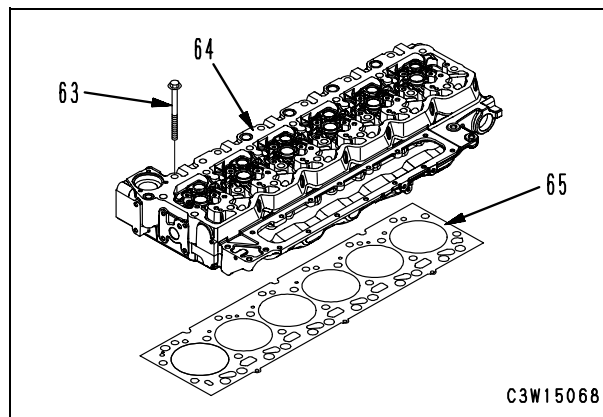

17. Remove upper 2 radiator mounting bolts (21).

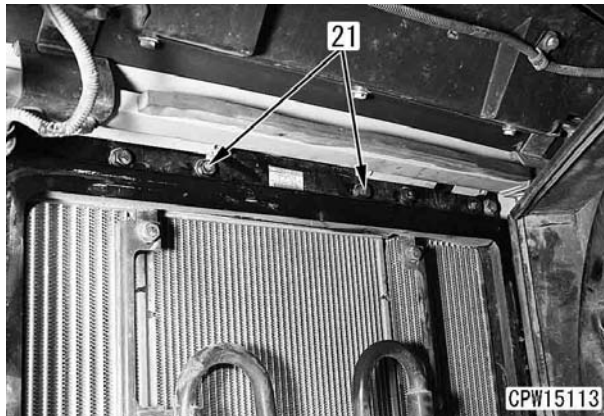

18. Remove radiator (22) from the left side. [*5]
★ When removing the radiator, take care not to damage it.





Installation

- Carry out installation in the reverse order to removal.

[*1]

 Air aftercooler upper hose clamp:
10.5 ± 0.5 Nm {1.07 ± 0.05 kgm}



[*2]

 Radiator upper hose insertion area:
Gasket sealant (THREEBOND 1206E or equivalent)
 Radiator upper hose clamp:
8.8 ± 0.5 Nm {0.9 ± 0.05 kgm}

[*3]

 Air conditioner receiver tank mounting U-clamp: **10.8 – 26.0 Nm {1.1 – 2.7 kgm}**

[*4]

 Radiator lower hose insertion area:
Gasket sealant (THREEBOND 1206E or equivalent)
 Radiator lower hose clamp:
8.8 ± 0.5 Nm {0.9 ± 0.05 kgm}

[*5]

- ★ Fit grommet (23) to the mounting hole.
- ★ Check that projection (A) of the radiator is fitted to grommet.
- ★ When installing the radiator, set drain hose (24) in mounting hole (B) securely.

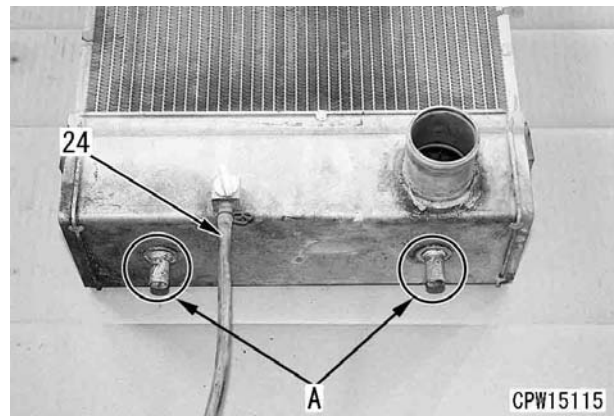

- **Refilling with coolant**
Add coolant through the coolant filler to the specified level. Run the engine to circulate the coolant through the system. Then, check the coolant level again.
-  Total amount of coolant: **Approx. 22 ℓ**
(For details, see "Table of fuel, coolant and lubricants")

5. Put the wrench [1] in part (A) (width across flats: 12.7 mm) of tensioner assembly (7) and turn it in the unwinding direction to decrease the tension of fan belt (8).

⚠ **Set the wrench [1] securely to part (A) of tensioner assembly (7) before turning it. (The spring of tensioner assembly (7) is strong. If the wrench [1] is set incompletely and turned, it comes off and that is very dangerous.)**

⚠ **After removing belt (8), return tensioner assembly (7) slowly and carefully.**

⚠ **Take care not to catch your finger between the pulley and fan belt (8) during work.**

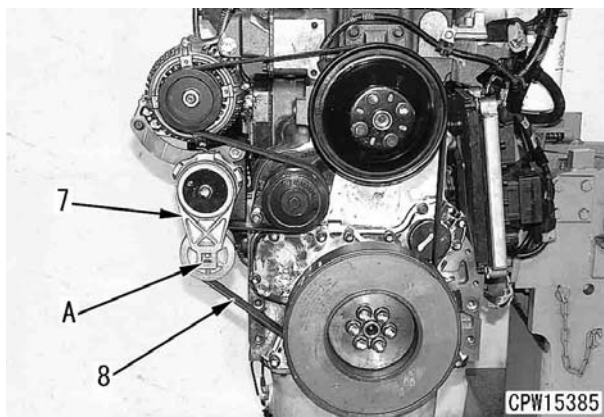

6. Remove 6 mounting bolts (9) and vibration damper (10).

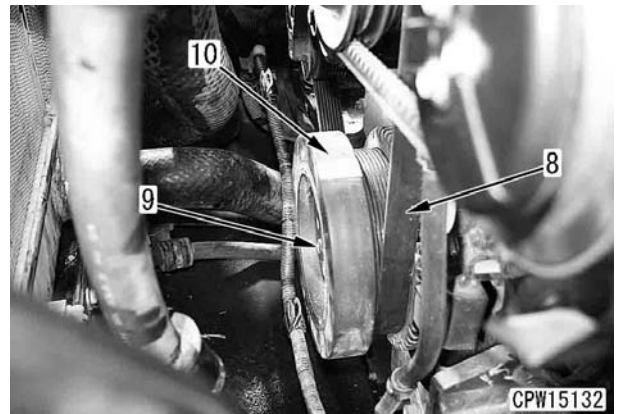

7. Remove engine front oil seal (11).

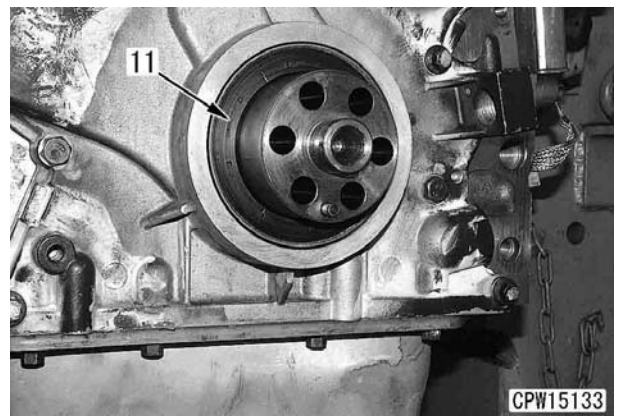

10. Disconnect brake strainer hose (8).

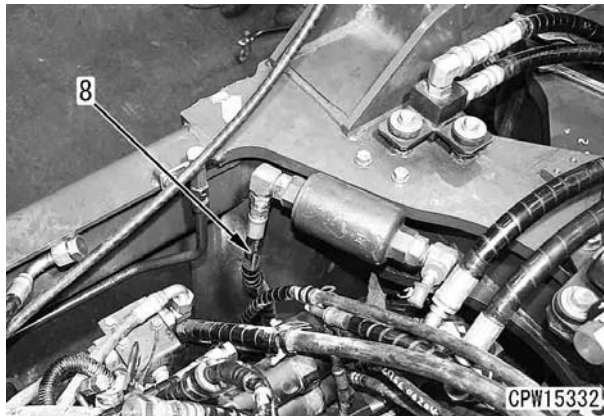

11. Disconnect front drive shaft (9) from the transfer. [*2]



12. Remove rear drive shaft (10). [*3]

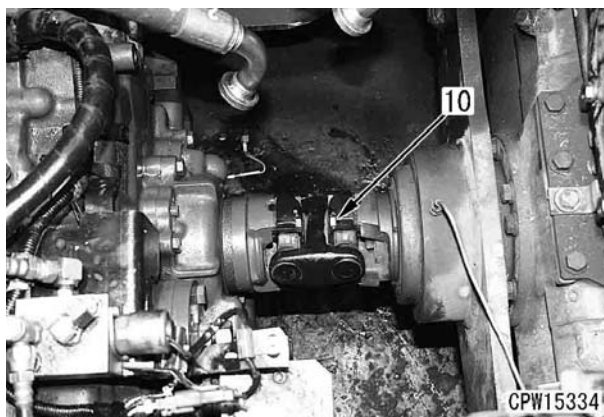

13. Remove parking brake cable clamp and bracket assembly (11) in the left frame.

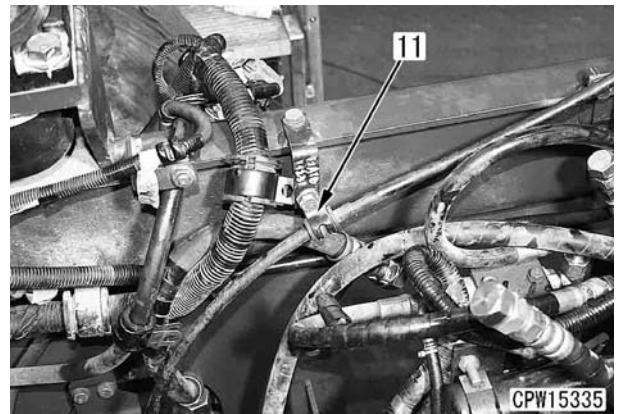

14. Remove 2 hose clamps (12) in the right frame.

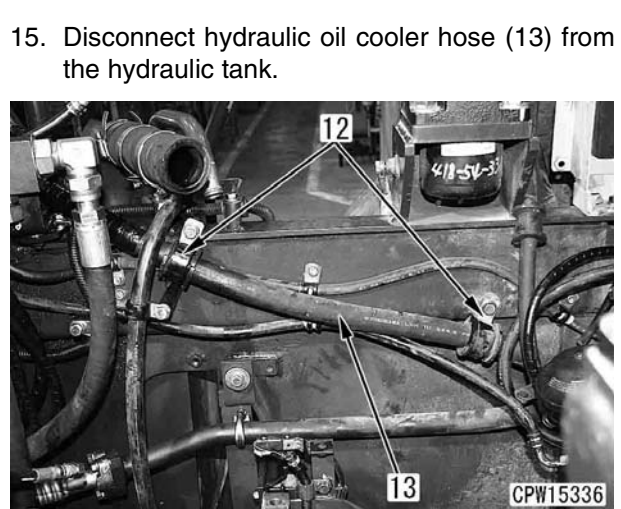

15. Disconnect hydraulic oil cooler hose (13) from the hydraulic tank.

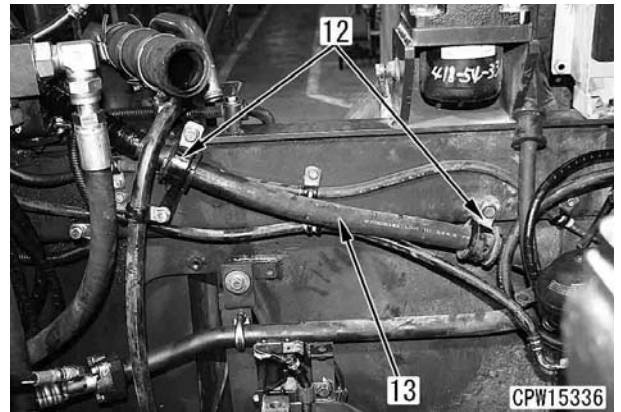

16. Remove wiring harness clamp (14) in the left frame.

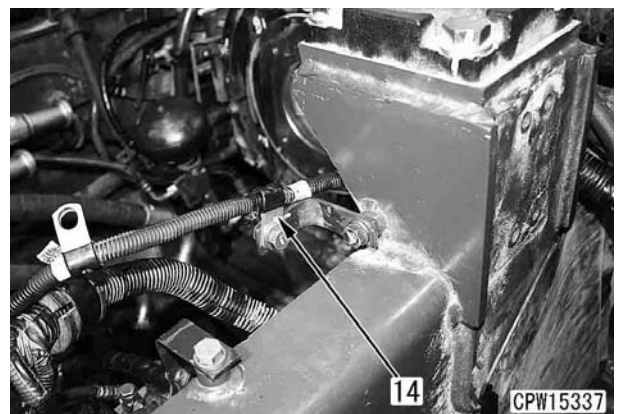

17. Sling the transfer and HST motor assembly.

Assembly

- ★ Clean the all parts and check them for dirt or damage. Coat their sliding surfaces with power train oil (for details, see "Table of fuel, coolant and lubricants") before installing.
- ★ Before icing a bearing in dry ice for expansion fit, drop about 6 cc of power train oil (for details, see "Table of fuel, coolant and lubricants") onto it and rotate it 10 turns.

1. Rear case

- 1) Press fit outer race (81) to rear case (80).

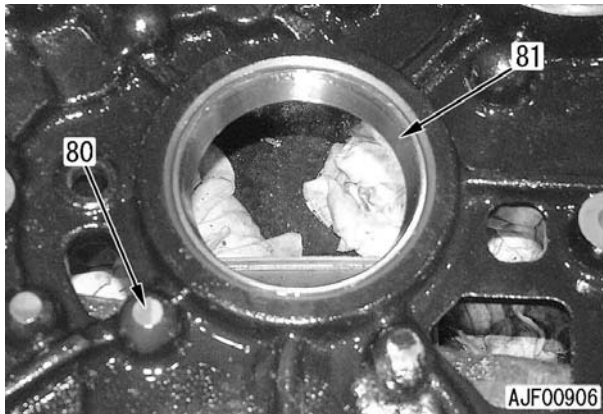

2. Assembly of output shaft and gear assembly

- 1) Using tool **D1** and the press, press fit rear bearing (72) to output shaft (73) until it stops.
 - ★ After press fitting the bearing, apply power train oil (for details, see "Table of fuel, coolant and lubricants") to it and rotate it.

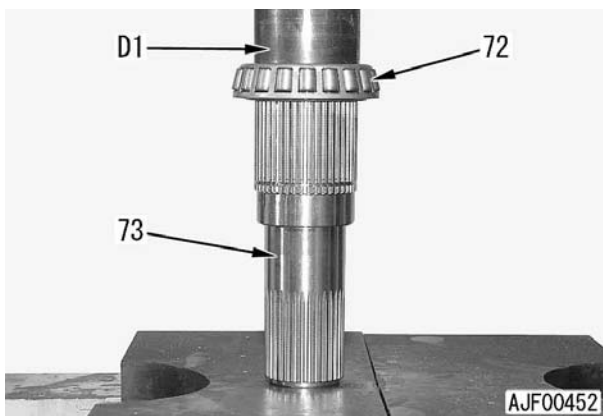

- 2) Install output gear (71) and snap ring (70).
 - 🔧 Spline of gear: **Grease (LM-G)**

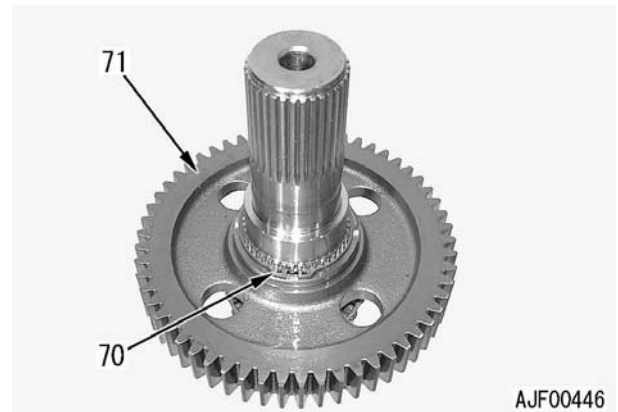

- 3) Using tool **D2** and the press, press fit front bearing (69).
 - ★ After press fitting the bearing, apply power train oil (for details, see "Table of fuel, coolant and lubricants") to it and rotate it.

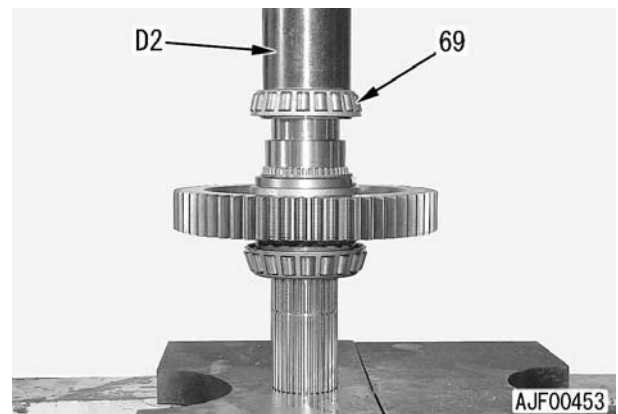

3. Installation of output shaft and gear assembly

- 1) Place cover (67) on the gear and install output shaft and gear assembly (68) to the rear case.
- 2) Install the mounting bolts of cover (67).
 - ★ Check that cover (67) does not interfere with the inside surface of the gear.
 - 🔧 Mounting bolt: **Adhesive (LT-2)**
 - 🔧 Mounting bolt: **98 – 123 Nm {10.0 – 12.5 kgm}**

Installation

- Carry out installation in the reverse order to removal.

[*1]

- ☞ Rear drive shaft mounting bolt:
59 – 74 Nm {6.0 – 7.5 kgm}

★ Precautions for installing rear drive shaft

- 1) Check that the key of the spider cap is fitted to the key way of the mating yoke and then tighten the mounting bolts.
- 2) Check that the lateral runout of the rear axle and transfer from each other is 3 mm or less.
- 3) If the runout in 2) is 3 mm or larger, adjust the transfer cushion and transfer mount to reduce the runout.

[*2]

- ★ After installing the parking brake, open cotter pin (3) to 180° to fix.

[*3]

- ★ Using tool **D8**, install parking brake assembly (6).

- ☞ Parking brake mounting bolt:
98 – 123 Nm {10.0 – 12.5 kgm}

• Refilling with oil (Transfer case)

Add oil through the oil filler to the specified level. Run the engine to circulate the oil through the system. Then, check the oil level again.

-  Power train oil: **Approx. 5 l (TO10)**

Disassembly and assembly of axle housing assembly

Special tools

Symbol	Part No.	Part Name	Necessity	Q'ty	New/Remodel	Sketch	
H	1	793T-623-1170	Push tool	■	1		○
		793T-422-1230	Push tool	■	1		○
		793T-423-1110	Push tool	■	1		○
	2	793T-422-1240	Seal support	■	2		○
		793T-423-1120	Seal support	■	2		○
		01016-50860	Bolt	■	6		
	3	793T-659-1110	Push tool	■	1		○
		790-201-2750	Spacer	■	1		
	4	793T-423-1150	Holder	■	1		○
	5	790-101-5201	Push tool kit	■	1		
		790-101-5271	• Plate		1		
		790-101-5221	• Grip		1		
01010-51225		• Bolt		1			
6	790-101-3101	Bearing puller	●	1			
7	790-101-3501	Gear puller	●	1			
8	791T-465-1130	Push tool	■	1		○	
	790-201-2670	Plate	■	1			
9	799-501-1120	Pin	■	1			
10	790-445-5980	Guide bar	■	1			
11	Commercially available	Dial gauge	●	1			
12	79A-264-0021	Push-pull scale	●	1			

Disassembly

★ The following photos and illustrations show the front axle housing as an example.

1. Draining oil

 Axle (Each of front and rear axles): **18 ℓ**

2. Axle assembly

- 1) Set the axle assembly on block [1].
 - ★ Set block [1] so that the axle assembly will not lean when the housing assembly on one side is removed.

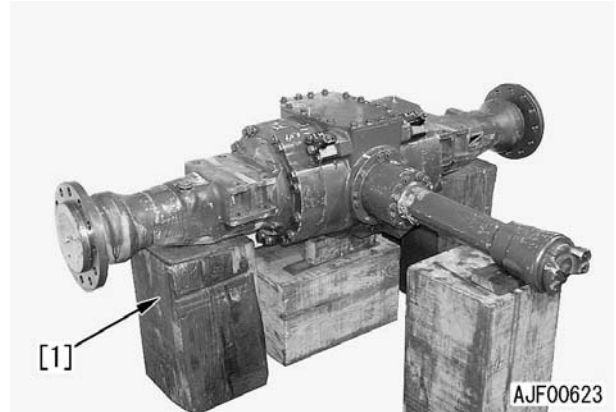

3. Axle housing assembly

- 1) Sling axle housing assembly (1) temporarily and remove the housing mounting bolts.
 - ★ When removing both axle housing assemblies, make match marks on the housings and differential case so that the housing assemblies will not be mistaken.
- 2) Remove axle housing assembly (1).

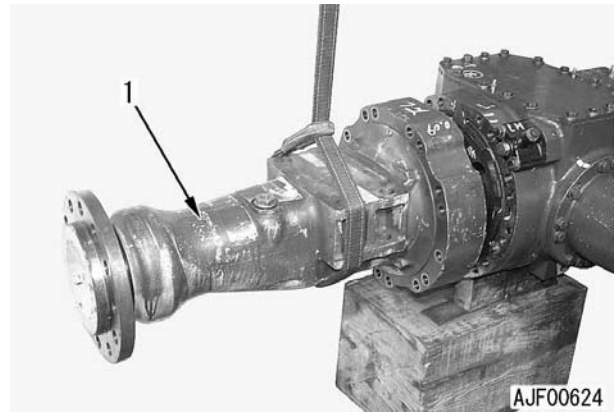

- 3) Set axle housing assembly (1) with the planetary carrier side up.



- 3) Remove snap ring (28) and ring (29), and then remove bearing (30) from long cage (27).

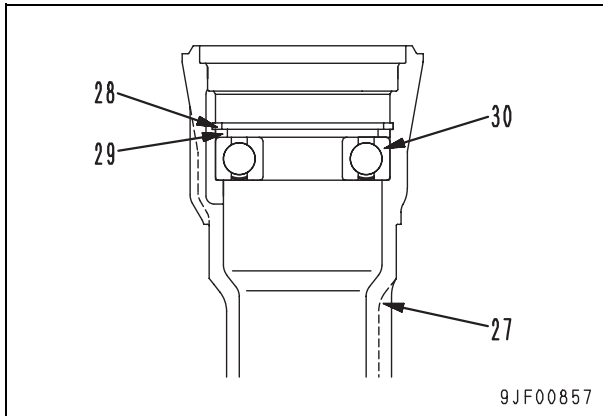

12. Removal of front cage assembly (Front differential)

- 1) Using tool H14, loosen nut (31) before removing the cage assembly.

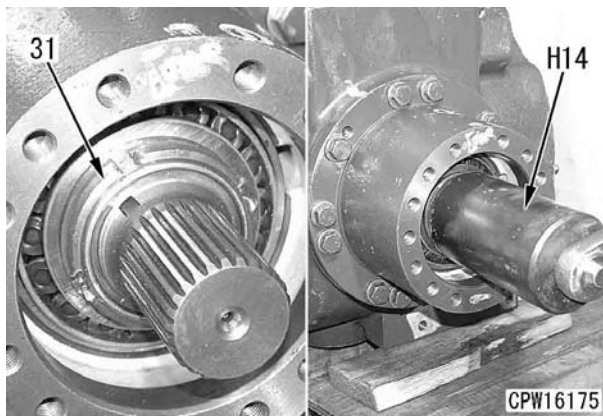

- 2) Remove the mounting bolts. Using tool H24, remove front cage assembly (32).
★ Check the thickness and quantity of the shims.

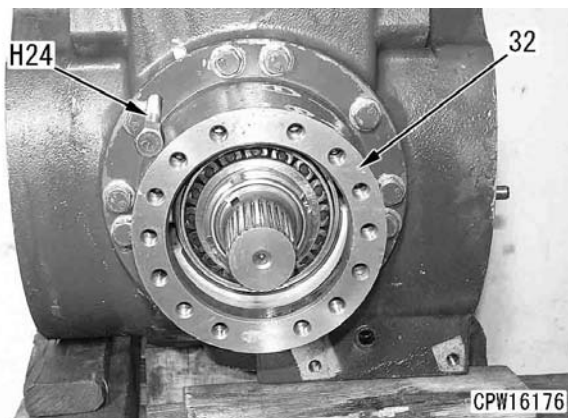

13. Removal of rear cage assembly (For rear differential)

- 1) Before removing cage assembly, loosen the mounting bolts of coupling (41).
- 2) Remove the mounting bolts. Using tool H24, remove rear cage assembly (42).
★ Check the thickness and quantity of the shims.

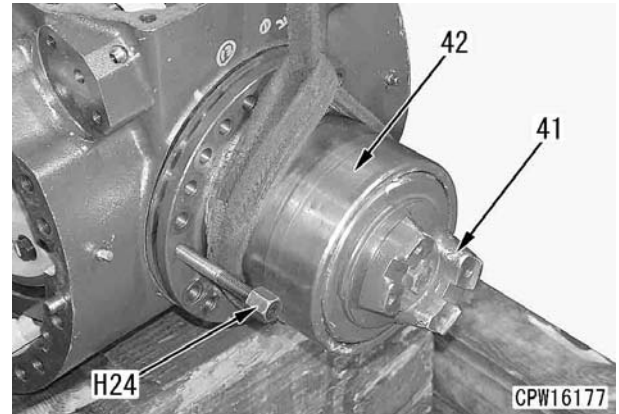

14. Disassembly of front cage assembly (For front differential)

- 1) Remove nut (31) and holder (33).

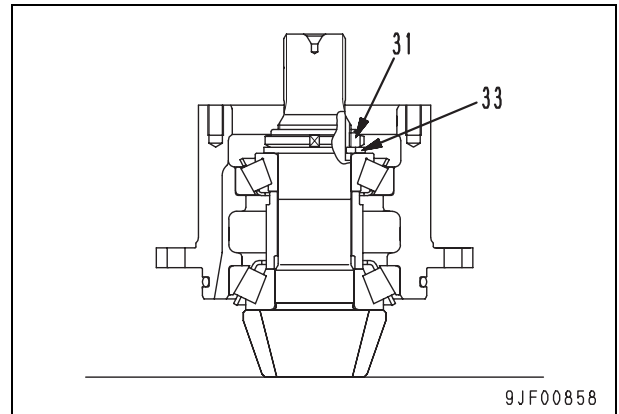

- 2) Using tool H25, push out pinion gear assembly (81) with a press.

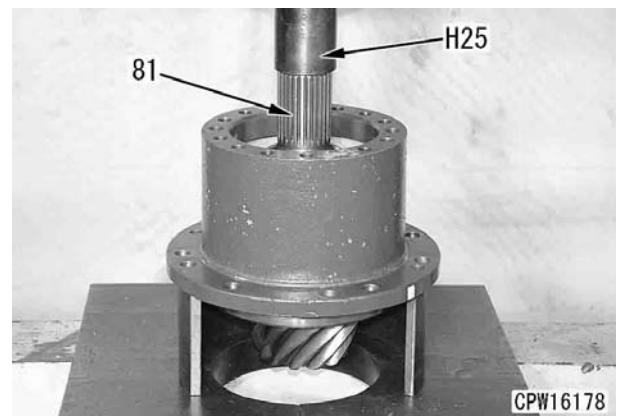

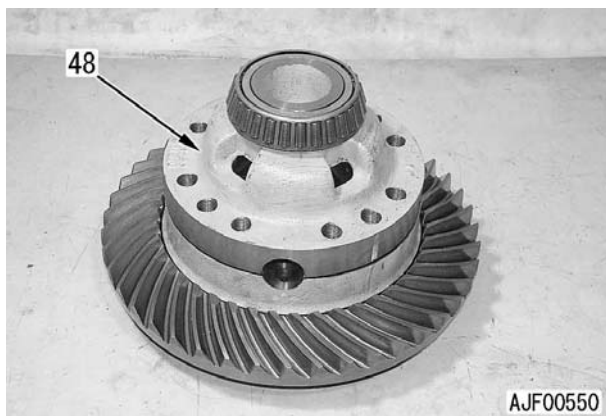

3. Installation of differential assembly

- 1) Sling differential carrier assembly (43) and set it to the mounting section of differential case.
 - ★ Take care that the sling will not come off.
 - ★ Do not damage the bearing of the differential carrier assembly by hitting it against the differential case.

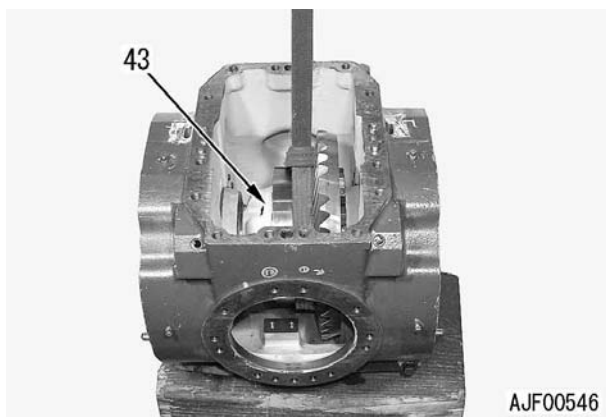

4. Bearing carrier

- 1) Install outer race (86).
- 2) Install ring (85) and seal (84) to bearing carrier (44).



- 3) Using tool **H24**, install shim (87) and both bearing carriers (44).

- ★ Install the shims of the thickness and quantity checked when disassembled to each bearing carrier.
- ★ Turning the bevel gear, tighten the mounting bolts.

 Bearing: **Axle oil (AXO80)**

 Mounting bolt:

98 – 123 Nm {10.0 – 12.5 kgm}

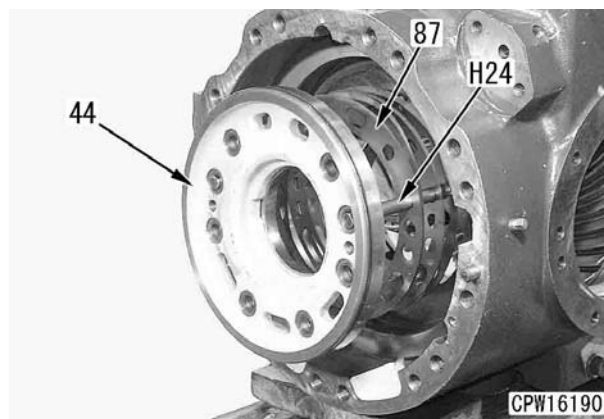

- ★ Rotate the bearing several turns to spread axle oil (AXO80) into it.
- 4) Using tool **H12**, measure the starting torque of the bevel gear in the tangential direction.

- Starting torque:

8.8 – 20.6 N {0.9 – 2.1 kg}

- ★ If the starting torque is out of the standard range, adjust it by increasing or decreasing the shim thickness.
- Varieties of shim thickness:
0.05 mm, 0.2 mm, 0.3 mm, 0.8 mm
- ★ Limit the shim thickness after the adjustment to 0.5 – 1.35 mm on each side.

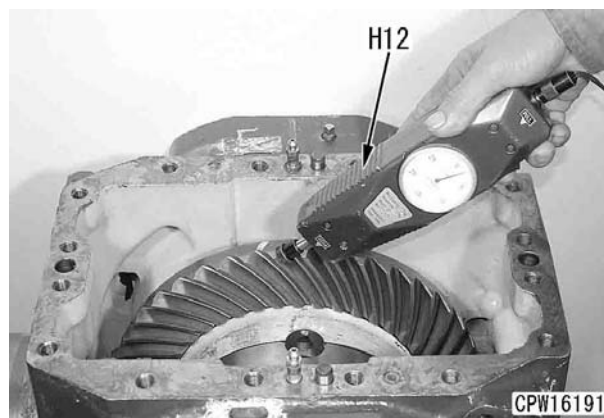

WHEEL LOADER

WA250-6

WA250PZ-6

Machine model	Serial number
WA250-6	75001 and up
WA250PZ-6	75160 and up H00051 and up

50 Disassembly and assembly

400 Undercarriage and frame

Removal and installation of center hinge pin	2
Removal and installation of counterweight	12

9. Sling counterweight (11) temporarily and remove the mounting bolt, and then remove counterweight (11). [*1]

- ★ When removing the counterweight, insert bar [1] in its rear part to balance it.

 Counterweight and batteries (both)
assembly: **1,550 kg**

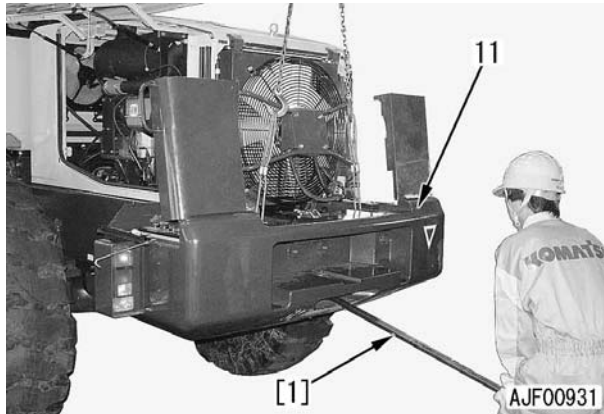

Installation

- Carry out installation in the reverse order to removal.

[*1]

 Mounting bolt:
785 – 980 Nm {80 – 100 kgm}

- 1] Remove the assembly of pistons (57) and retainer (58) from cylinder block (56).
- 2] Remove 9 pistons (57) from retainer (58).

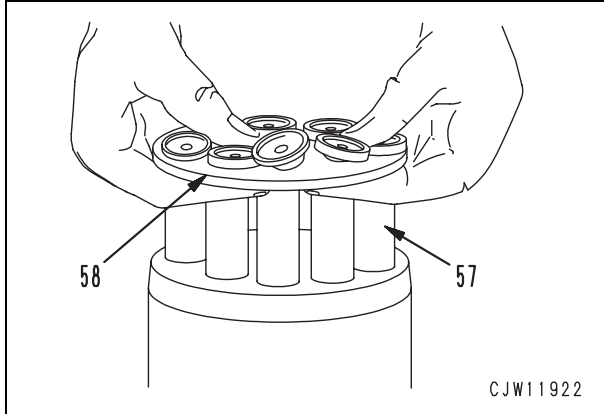

- 3] Remove retainer guide (59) from cylinder block (56).
- 4] Remove shim (60) and spring (61).

- ★ When any of cylinder block (56), control plate (52), retainer guide (59), retainer (58), and shim (60) needs to be replaced, replace the whole cylinder block since a dimension of shim (60) must be adjusted.

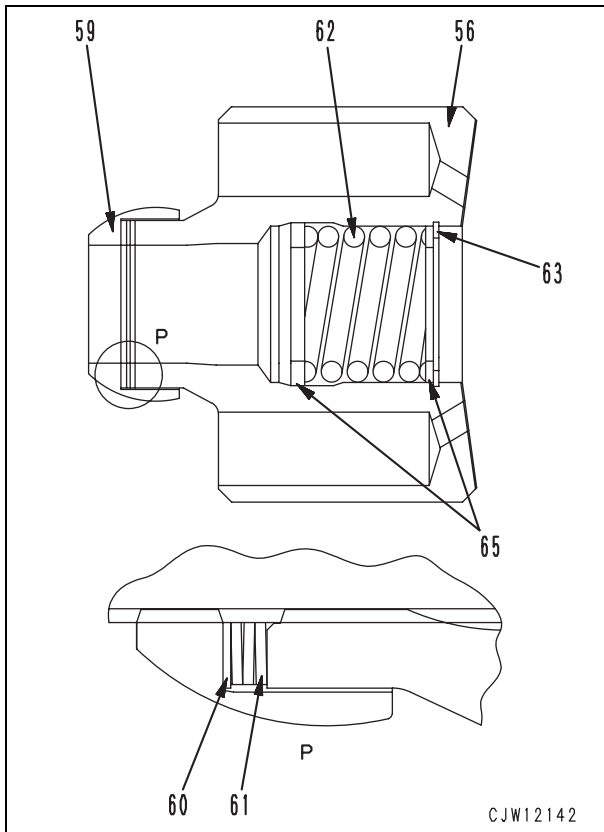

- 5] Remove snap ring (63) from the cylinder block.
- ⚠ **Snap ring (63) will jump out. Take care.**
- 6] Remove spring (62) and 2 shims (65).

- ★ Check of pistons
 - Check that there are no scratches or metal deposits on sliding surface (b), and there is no axial play (c), (otherwise: pistons must be replaced in sets).

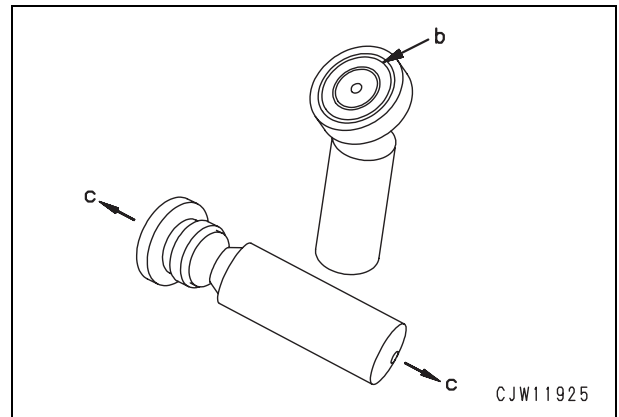

- ★ Check of cylinder block and control plate.
 - Cylinder bores (d), splines (e).

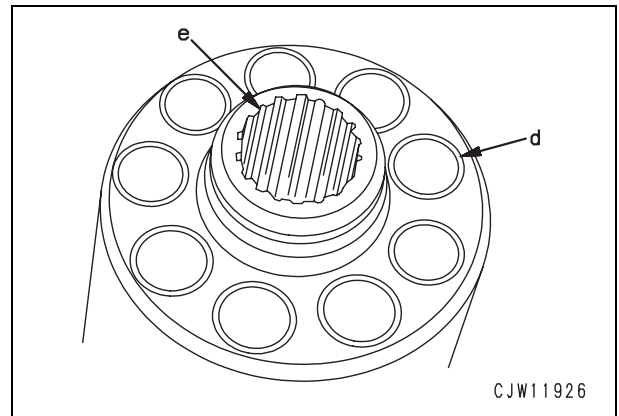

7. Port plate (51)

- 1) Assemble port plate (51), matching (m1).
⚠ Spring preloaded!
- 2) Insert port plate assembly (51) into housing, guidance with 2 guide bolts [1] that screwed opposite angle.

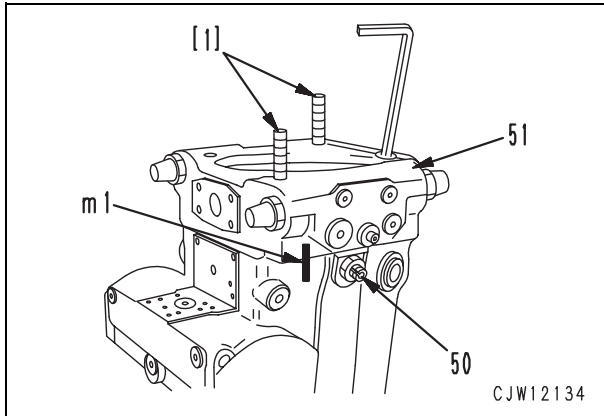

- 3) Locking screw (50) – observe adjusting measure, the angle (m0).

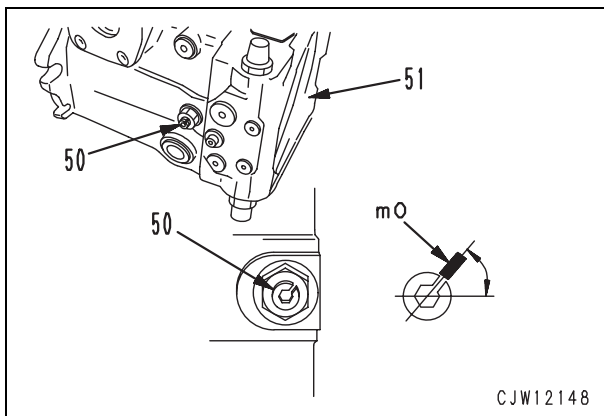

8. Servo piston cover

- 1) Install servo piston covers (80) and (81) to both sides match mark positions (m2) and (m3).
- ★ Cover (80) will be removed because of filling oil.

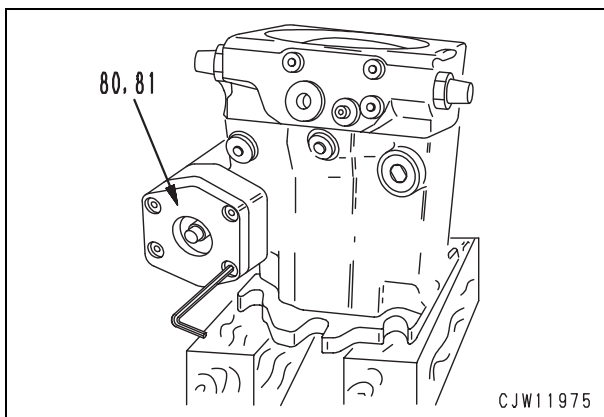

9. Charge pump assembly (44)

- 1) Install wear plate (43).
- 2) Install coupling (48) and key (49).
 ★ Bearing metal (47) is already in the flange (45).
- 3) Install gear (46) to flange (45).
- 4) Install charge pump assembly (44) with 4 mounting bolts (97).

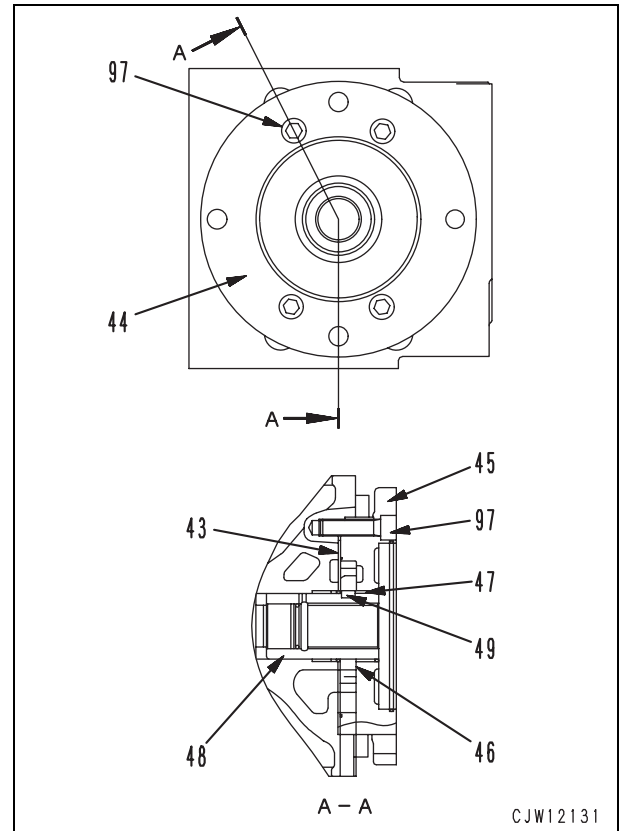

Removal and installation of HST motor 2 assembly

Removal

- ⚠ Stop the machine on a level ground and set the lock bar to the frame to fix the front and rear frames.
- ⚠ Lower the work equipment to the ground, stop the engine, apply the parking brake, and put chocks under the tires.
- ⚠ Operate the work equipment control lever 2 – 3 times to release the residual pressure in the work equipment circuit.
- ⚠ Press the brake pedal at least 100 times to release the residual pressure in the brake accumulator circuit.
- ⚠ Disconnect the cable from the negative (-) terminal of the battery.

- **Precautions for handling refrigerant**

- ⚠ **Collect refrigerant (R134a) beforehand.**
 - ★ Ask professional traders for collecting and filling the refrigerant (R134a).
 - ★ Never release the refrigerant (R134a) to the atmosphere.
- ⚠ **If the refrigerant (R134a) gets inside ones eyes, it may cause blindness. Therefore, make sure to wear protective glasses when collecting or filling the refrigerant. Collecting and filling work must be conducted by a qualified person.**
- ⚠ **If the radiator coolant temperature is high, you may scald yourself with the hot coolant when disconnecting the heater hoses and draining the coolant. Wait until the coolant is cooled, and then drain the coolant.**

1. Recover the refrigerant (R134a). [*1]
2. Loosen the radiator cap to drain the coolant.
 Radiator: 22 ℓ
3. Remove the operator's cab and floor frame assembly. For details, see "Removal and installation of operator's cab and floor frame assembly".

4. Disconnect front drive shaft (1) from the transfer. [*2]



5. Disconnect the following wiring harness connectors from the brake accumulator.
 - (2): CN-T07
 - (3): CN-T10

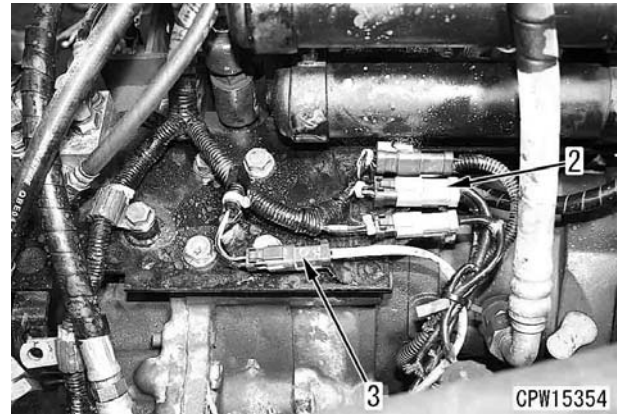

6. Disconnect the following hoses from HST motor 1.
 - (4): T1 port hose
 - (5): T2 port hose
 - (6): A port hose
 - (7): B port hose

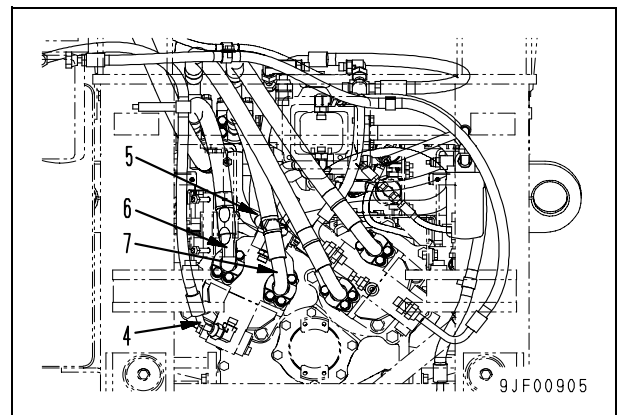

- 2) Insert shaft and rotary group assembly (81) into housing (82) to seat position.

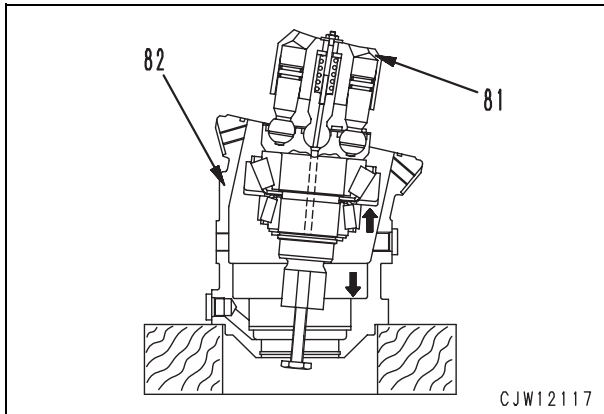

- 3) Insert screw [6] (M12 × 100 mm or longer). (Fix the tapered part of cylinder block (83) and set the angle to 0 degree.)
- 4) Remove screw [2].
- 5) Install O-ring (75) to the housing.

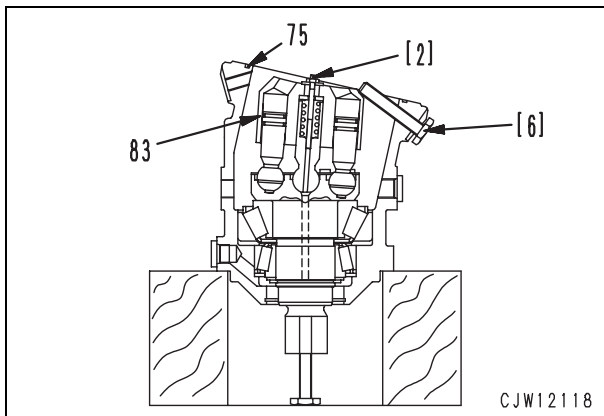

3. Port plate assembly (6)

- 1) Assemble port plate assembly (6) according to the following procedure.
 - 1] Install valve seat (79).
 - 2] Install poppet (78).
 - 3] Install valve guide (77).

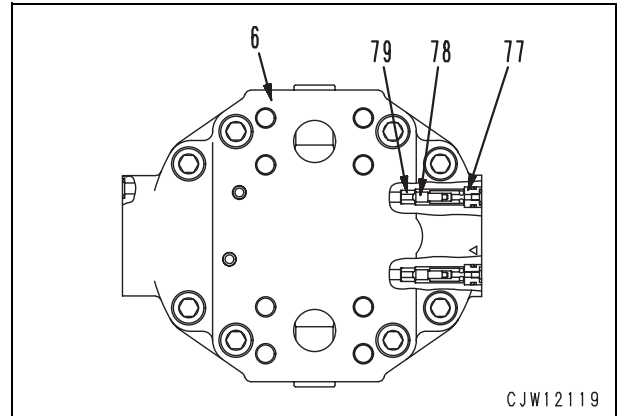

- ★ Piston (69), rod (72), and screw (76) are already in the port plate (6).
- 4] Install piston (74) and bolt (73).
- 5] Thinly apply grease to control plate (80), and then install it to the sliding surface of the port plate assembly (6).

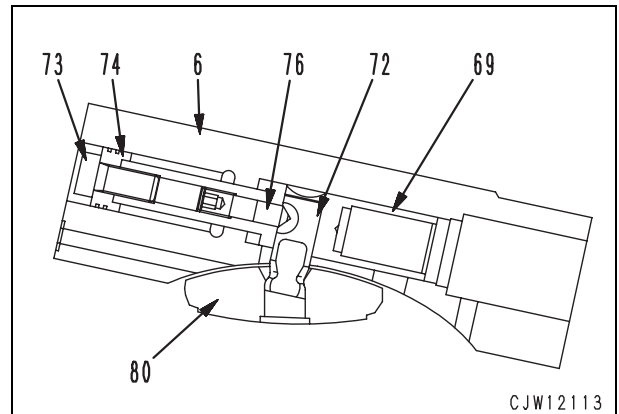

7. Disassembly of cylinder head assembly

- 1) Remove O-ring and backup ring (12).
- 2) Remove snap ring (13) and dust seal (14).
- 3) Remove rod packing (15).
- 4) Remove bushing (16).
- 5) Remove O-ring (17).

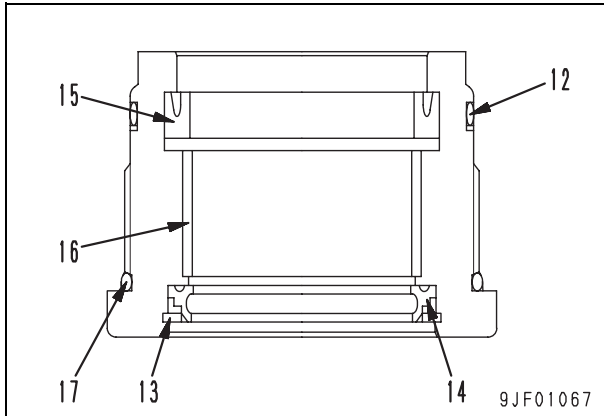

8. Disassembly of cylinder head assembly (Lift and bucket cylinder assembly)

- 1) Remove O-ring and backup ring (12).
- 2) Remove snap ring (13) and dust seal (14).
- 3) Remove rod packing (15).
- 4) Remove bushing (16).

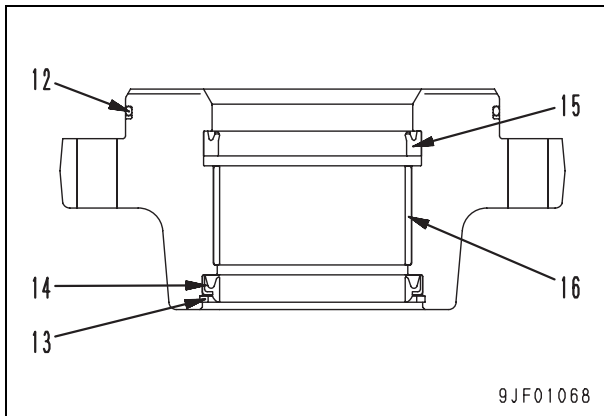

Assembly

- ★ Take care not to damage the packings, dust seals, O-rings, etc.
- ★ Do not insert each backup ring forcibly, but warm it in water at 50 – 60°C and then insert it.

1. Assembly of cylinder head assembly (Steering cylinder assembly)

- 1) Using tool **U4**, press fit bushing (16).

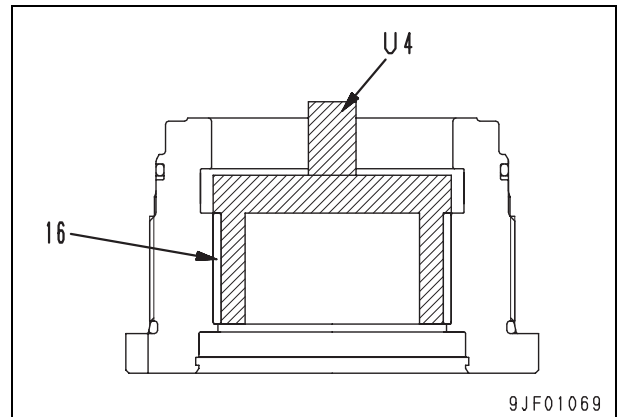

- 2) Install rod packing (15).
- 3) Using tool **U5**, install dust seal (14) and secure it with snap ring (13).
- 4) Install backup ring and O-ring (12).
- 5) Install O-ring (17).

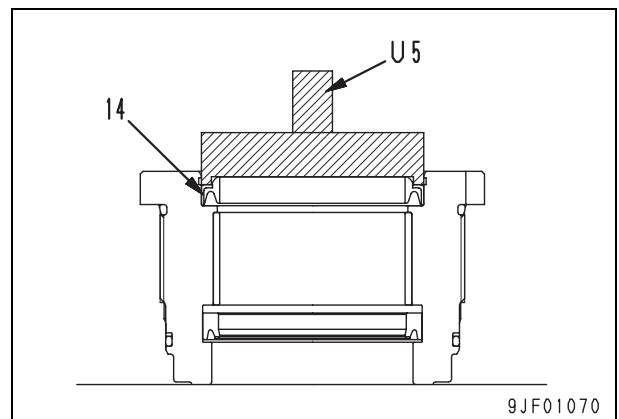
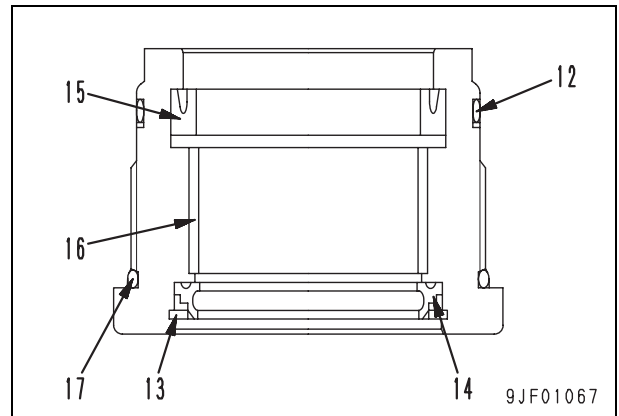

CLICK HERE TO **DOWNLOAD** THE COMPLETE MANUAL

- Thank you very much for reading the preview of the manual.
- You can download the complete manual from: www.heydownloads.com by clicking the link below



- Please note: If there is no response to CLICKING the link, please download this PDF first and then click on it.

CLICK HERE TO **DOWNLOAD** THE COMPLETE MANUAL