

SHOP MANUAL

PW95R-2

HYDRAULIC EXCAVATOR

SERIAL NUMBER

PW95R-2 21D0210001 and up

PW95R-2 21D0220001 and up



CLICK HERE TO **DOWNLOAD** THE COMPLETE MANUAL

- Thank you very much for reading the preview of the manual.
- You can download the complete manual from: www.heydownloads.com by clicking the link below



- Please note: If there is no response to CLICKING the link, please download this PDF first and then click on it.

CLICK HERE TO **DOWNLOAD** THE COMPLETE MANUAL

HOISTING INSTRUCTIONS

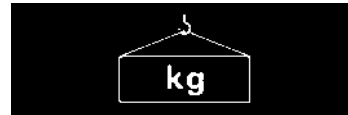

⚠ Heavy parts (25 kg or more) must be lifted with a hoist etc. In the **Disassembly and Assembly** section, every part weighing 25 kg or more is clearly indicated with the symbol .

1. If a part cannot be smoothly removed from the machine by hoisting, the following checks should be made:
 - Check for removal of all bolts fastening the part to the relative parts.
 - Check for any part causing interference with the part to be removed.

2. Wire ropes

- 1) Use adequate ropes depending on the weight of parts to be hoisted, referring to the table below:

| WIRE ROPES (Standard «S» or «Z» twist ropes without galvanizing) | |
|--|-----------------------|
| Rope diameter (mm) | Allowable load (tons) |
| 10.0 | 1.0 |
| 11.2 | 1.4 |
| 12.5 | 1.6 |
| 14.0 | 2.2 |
| 16.0 | 2.8 |
| 18.0 | 3.6 |
| 20.0 | 4.4 |
| 22.4 | 5.6 |
| 30.0 | 10.0 |
| 40.0 | 18.0 |
| 50.0 | 28.0 |
| 60.0 | 40.0 |

The allowable load value is estimated to be one-sixth or one-seventh of the breaking strength of the rope used.

- 2) Sling wire ropes from the middle portion of the hook. Slings near the edge of the hook may cause the rope to slip off the hook during hoisting, and a serious accident can result.

Hooks have maximum strength at the middle portion.

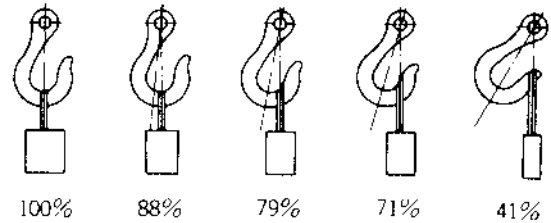

- 3) Do not sling a heavy load with one rope alone, but sling with two or more ropes symmetrically wound on to the load.

⚠ Slings with one rope may cause turning of the load during hoisting, untwisting of the rope, or slipping of the rope from its original winding position on the load, which can cause dangerous accidents.

- 4) Do not sling a heavy load with ropes forming a wide hanging angle from the hook.

When hoisting a load with two or more ropes, the force subjected to each rope will increase with the hanging angles.

The table below shows the variation of allowable load (kg) when hoisting is made with two ropes, each of which is allowed to sling up to 1000 kg vertically, at various hanging angles.

When two ropes sling a load vertically, up to 2000 kg of total weight can be suspended.

This weight becomes 1000 kg when two ropes make a 120° hanging angle.

On the other hand, two ropes are subjected to an excessive force as large as 4000 kg if they sling a 2000 kg load at a lifting angle of 150°.

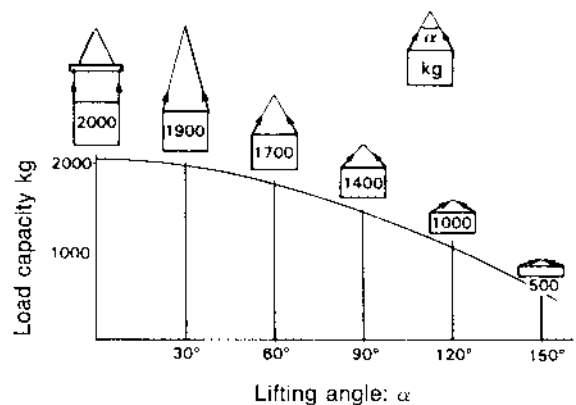

From liter to U.S. Gall.

1 ℓ = 0.2642 U.S. Gall.

| | 0 | 1 | 2 | 3 | 4 | 5 | 6 | 7 | 8 | 9 |
|----|--------|--------|--------|--------|--------|--------|--------|--------|--------|--------|
| 0 | 0 | 0.264 | 0.528 | 0.793 | 1.057 | 1.321 | 1.585 | 1.849 | 2.113 | 2.378 |
| 10 | 2.642 | 2.906 | 3.170 | 3.434 | 3.698 | 3.963 | 4.227 | 4.491 | 4.755 | 5.019 |
| 20 | 5.283 | 5.548 | 5.812 | 6.076 | 6.340 | 6.604 | 6.869 | 7.133 | 7.397 | 7.661 |
| 30 | 7.925 | 8.189 | 8.454 | 8.718 | 8.982 | 9.246 | 9.510 | 9.774 | 10.039 | 10.303 |
| 40 | 10.567 | 10.831 | 11.095 | 11.359 | 11.624 | 11.888 | 12.152 | 12.416 | 12.680 | 12.944 |
| 50 | 13.209 | 13.473 | 13.737 | 14.001 | 14.265 | 14.529 | 14.795 | 15.058 | 15.322 | 15.586 |
| 60 | 15.850 | 16.115 | 16.379 | 16.643 | 16.907 | 17.171 | 17.435 | 17.700 | 17.964 | 18.228 |
| 70 | 18.492 | 18.756 | 19.020 | 19.285 | 19.549 | 19.813 | 20.077 | 20.341 | 20.605 | 20.870 |
| 80 | 21.134 | 21.398 | 21.662 | 21.926 | 22.190 | 22.455 | 22.719 | 22.983 | 23.247 | 23.511 |
| 90 | 23.775 | 24.040 | 24.304 | 24.568 | 24.832 | 25.096 | 25.361 | 25.625 | 25.889 | 26.153 |

From liter to U.K. Gall.

1 ℓ = 0.21997 U.K. Gall.

| | 0 | 1 | 2 | 3 | 4 | 5 | 6 | 7 | 8 | 9 |
|----|--------|--------|--------|--------|--------|--------|--------|--------|--------|--------|
| 0 | 0 | 0.220 | 0.440 | 0.660 | 0.880 | 1.100 | 1.320 | 1.540 | 1.760 | 1.980 |
| 10 | 2.200 | 2.420 | 2.640 | 2.860 | 3.080 | 3.300 | 3.520 | 3.740 | 3.950 | 4.179 |
| 20 | 4.399 | 4.619 | 4.839 | 5.059 | 5.279 | 5.499 | 5.719 | 5.939 | 6.159 | 6.379 |
| 30 | 6.599 | 6.819 | 7.039 | 7.259 | 7.479 | 7.699 | 7.919 | 8.139 | 8.359 | 8.579 |
| 40 | 8.799 | 9.019 | 9.239 | 9.459 | 9.679 | 9.899 | 10.119 | 10.339 | 10.559 | 10.778 |
| 50 | 10.998 | 11.281 | 11.438 | 11.658 | 11.878 | 12.098 | 12.318 | 12.528 | 12.758 | 12.978 |
| 60 | 13.198 | 13.418 | 13.638 | 13.858 | 14.078 | 14.298 | 14.518 | 14.738 | 14.958 | 15.178 |
| 70 | 15.398 | 15.618 | 15.838 | 16.058 | 16.278 | 16.498 | 16.718 | 16.938 | 17.158 | 17.378 |
| 80 | 17.598 | 17.818 | 18.037 | 12.257 | 18.477 | 18.697 | 18.917 | 19.137 | 19.357 | 19.577 |
| 90 | 19.797 | 20.017 | 20.237 | 20.457 | 20.677 | 20.897 | 21.117 | 21.337 | 21.557 | 21.777 |

BRAKES

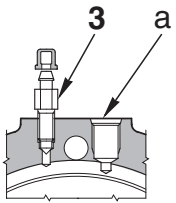
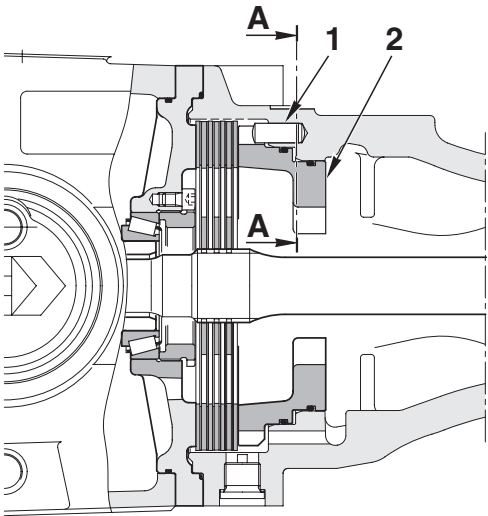

Section A - A

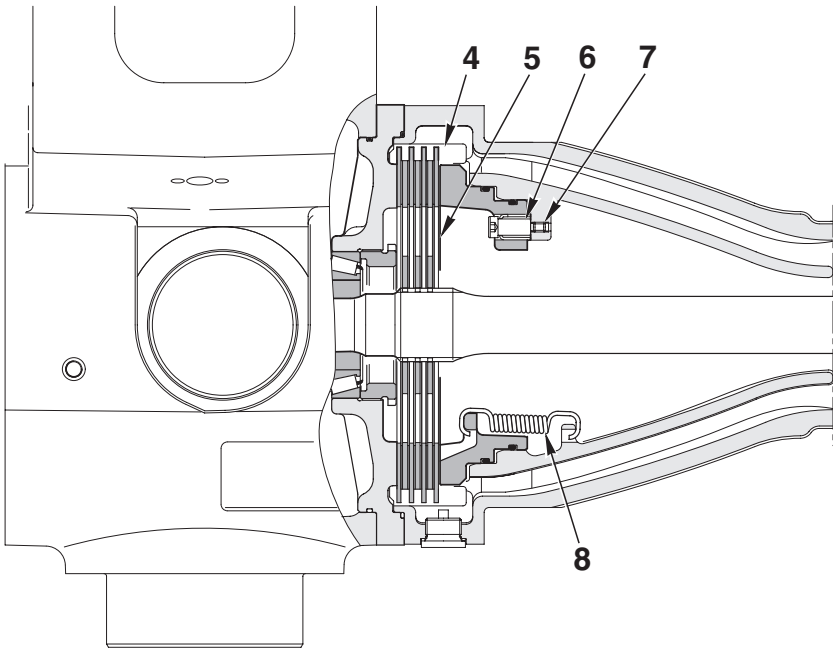

- 1. Pin
- 2. Pressure disk
- 3. Screw
- 4. Disk
- 5. Brake disk
- 6. Bushing
- 7. Screw
- 8. Spring

a. From swivel joint (7a Port)

RKP05381

STEERING SYSTEM

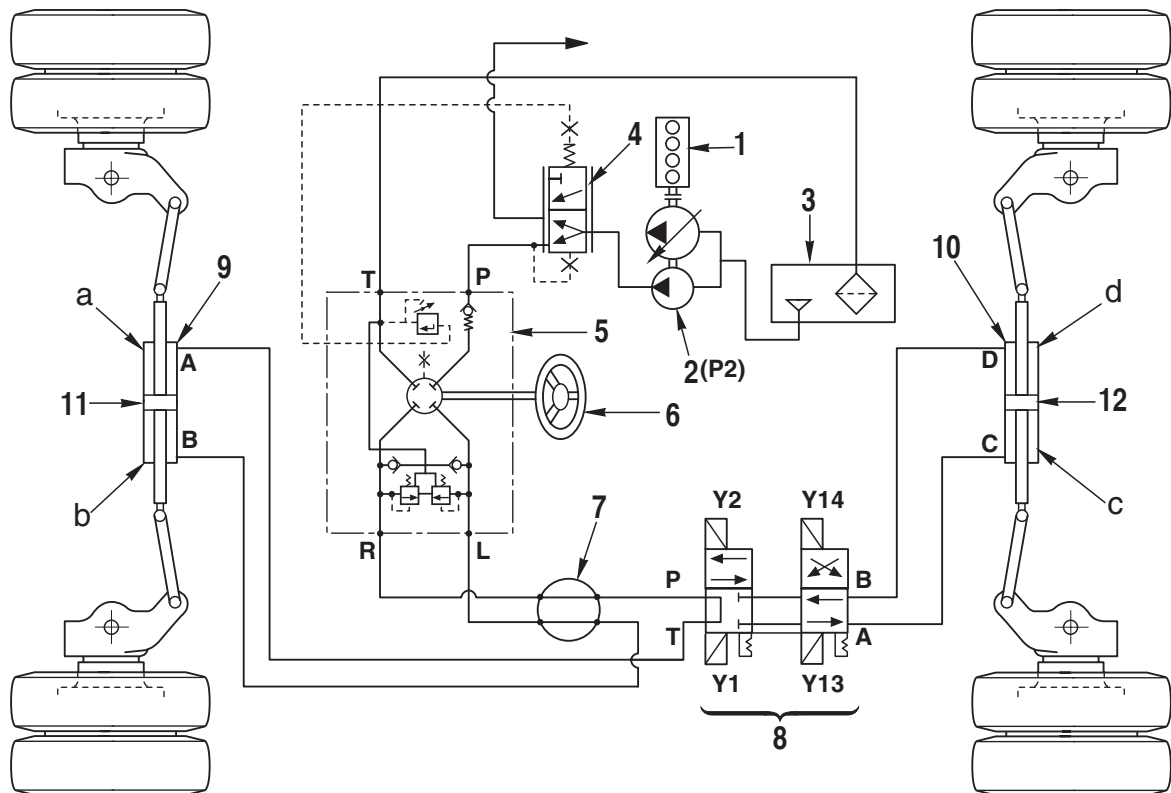

RKP10413

1. Engine
2. Pump (P2)
3. Tank
4. Priority valve
5. Steering unit
6. Steering wheel
7. Swivel joint
8. ST4 Solenoid valve group:
 - Y1: Rear steering cut out
 - Y2: Front/rear steering
 - Y13: Phase coincidence steering
 - Y14: Crab steering
9. Front axle steering cylinder
10. Rear axle steering cylinder
11. Front axle cylinder piston
12. Rear axle cylinder piston

DESCRIPTION

- The steering system is completely hydraulic. The oil required, supplied by the pump (2) driven by the motor (1), is sent to the priority valve (4) which functions by Load Sensing, and sends the necessary quantity of oil to the steering system (5), even when other oleodynamic components supplied by the same circuit are in operation. The oil passes from this group (5) into the swivel joint (7) and from there into the steering cylinders (9) and (10). The solenoid valve group (8) can switch the oil flow to provide three types of steering:
 - 1 - **2 wheels steering**
Steering condition in which the rear axle is excluded.
 - 2 - **2 wheels steering and 2 wheels countersteering.** Steering condition in which rear steering is activated and the direction of the rear wheels is contrary to that of the front wheels.
 - 3 - **4 wheels steering in the same direction.** Steering condition in which rear axle steering is activated and the direction of the rear wheels agrees with that of the front wheels.
- The hydraulic power supplied by the pump (2) is transferred to cylinders (9) and (10) and transformed into mechanical steering power.

HYDRAULIC CIRCUIT (WORK EQUIPMENT)

REAR OUTRIGGER AND FRONT BLADE VERSION

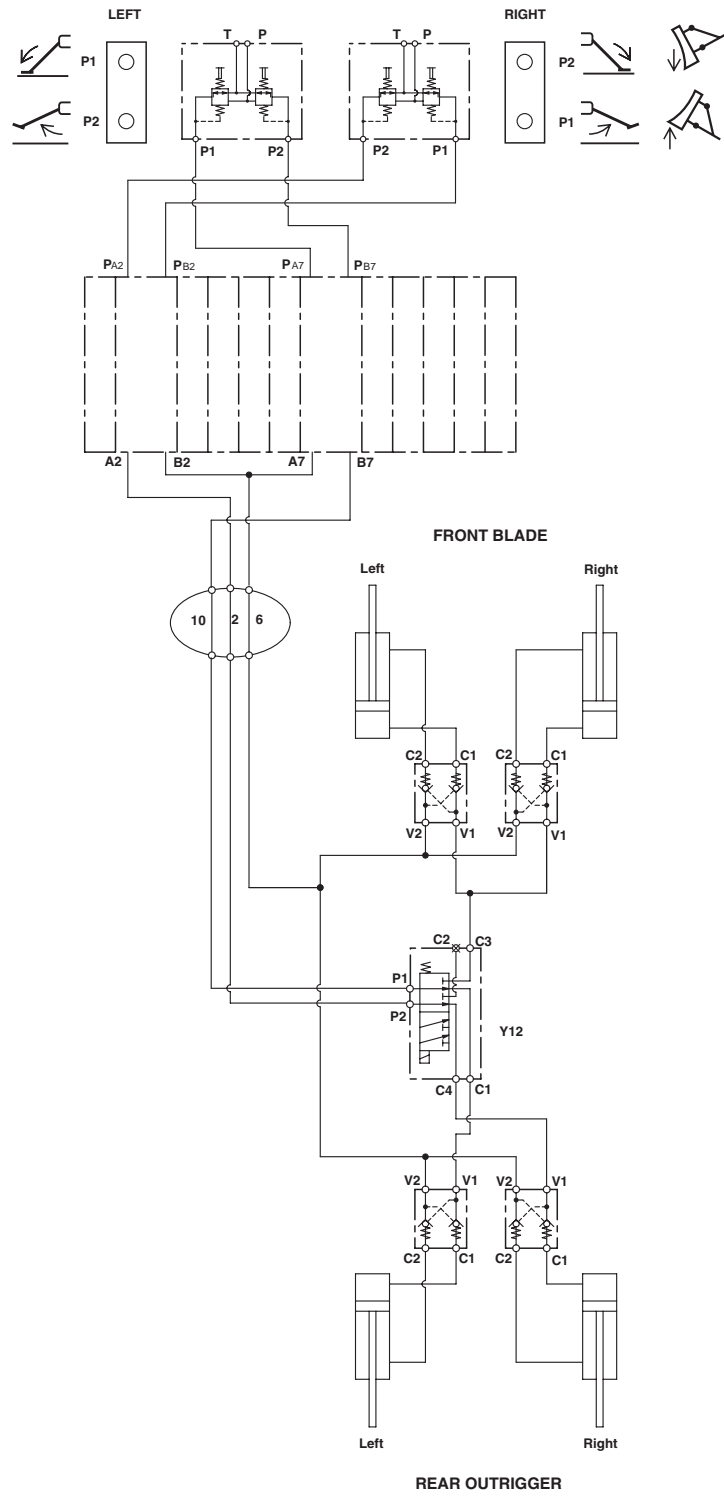

4 OUTRIGGER VERSION

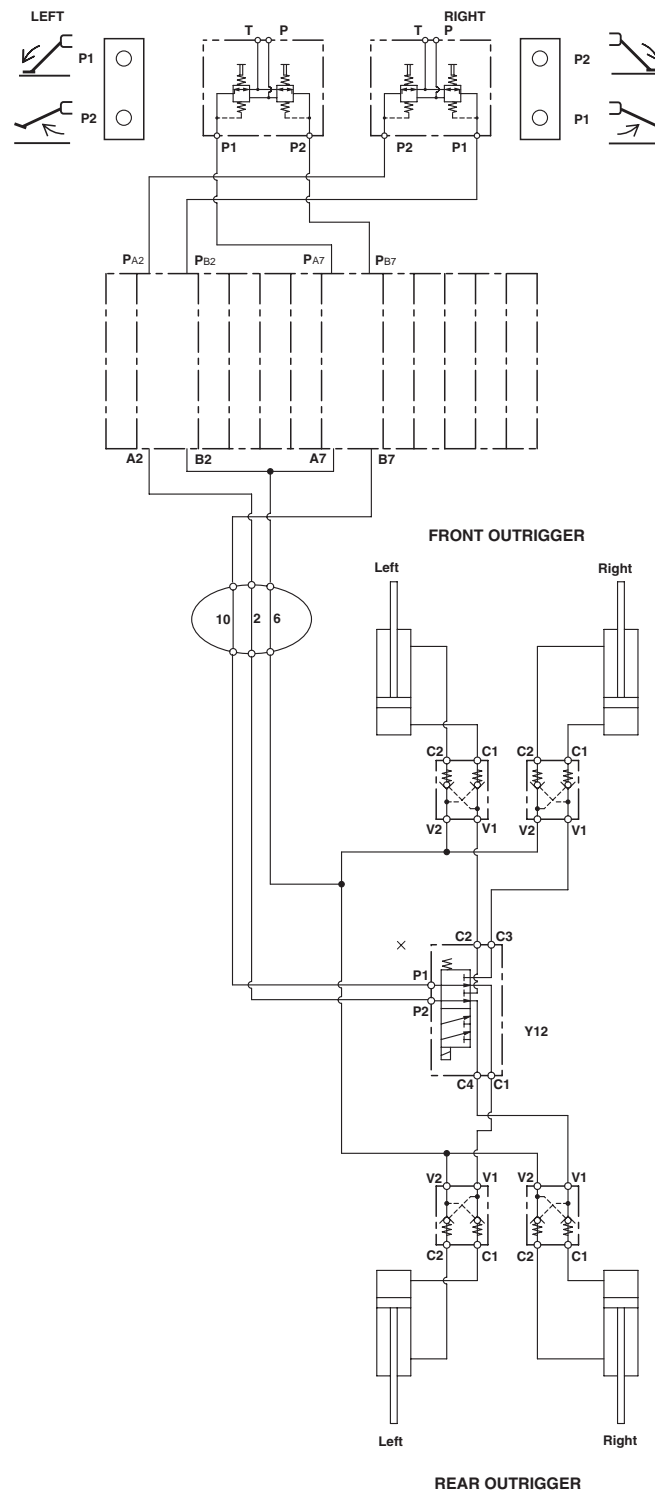

REAR BLADE VERSION

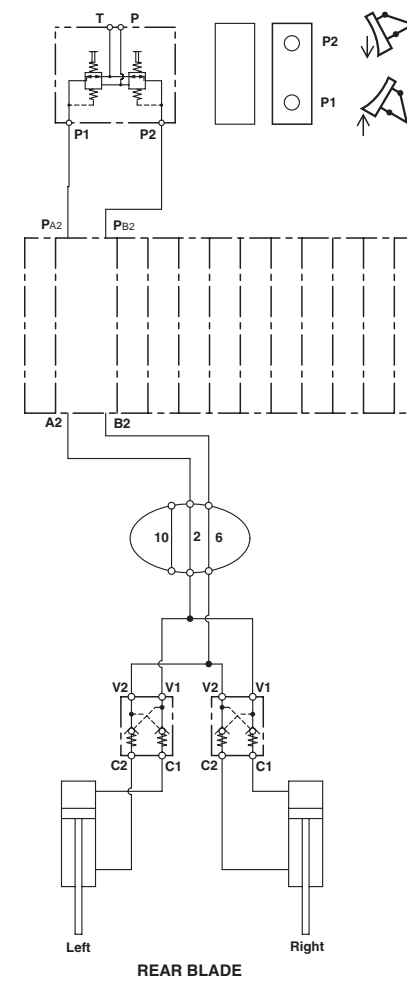

REAR OUTRIGGER VERSION

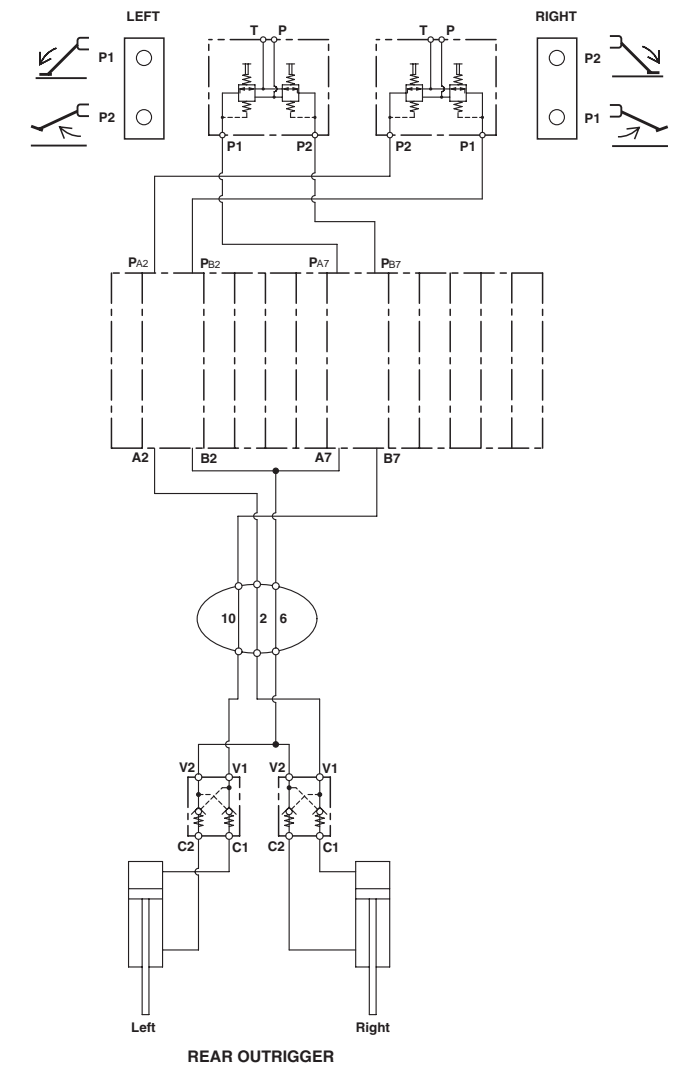

RKP07193

**PAGE INTENTIONALLY
LEFT BLANK**

a) Action of PC-EPC solenoid

- The command current from resistor flows to **PC-EPC** solenoid (1).
This command current acts on the **PC-EPC** valve and outputs the signal pressure.
When this signal pressure is received, the force pushing piston (2) is changed.
- On the opposite side to this force pushing piston (2) is the spring set pressure of springs (4) and (6) and pump pressure PP pushing spool (3). Spool (3) stops at a position where the combined force pushing spool (3) is balanced, and the pressure (pressure of port C) output from the CP valve.

- a. TC Port - To exchanger
- b. TSW Port - To swing motor (S Port)
- c. TB Port - To hydraulic tank
- d. A1 Port - To swing motor (MA Port)
- e. B1 Port - To swing motor (MB Port)
- f. A2 Port - See hydraulic circuit
- g. B2 Port - See hydraulic circuit
- h. A3 Port - To swivel joint (13A Port)
- i. B3 Port - To swivel joint (12A Port)
- j. A4 Port - To boom cylinder (bottom side)
- k. B4 Port - To boom cylinder (head side)
- l. A5 Port - To arm cylinder (head side)
- m. B5 Port - To arm cylinder (bottom side)
- n. A6 Port - To bucket cylinder (head side)
- o. B6 Port - To bucket cylinder (bottom side)
- p. A7 Port - See hydraulic circuit
- q. B7 Port - See hydraulic circuit
- r. A8 Port - To boom swing cylinder (head side)
- s. B8 Port - To boom swing cylinder (bottom side)
- t. A9 Port - To 2-piece boom cylinder (head side)
- u. B9 Port - To 2-piece boom cylinder (bottom side)
- v. A10 Port - To attachment (L.H. side)
- x. B10 Port - To attachment (R.H. side)
- y. P2 Port - From priority valve (EF Port)
- w. P1 Port - From servocontrol unit (P2 Port) and to pump (PB Port)
- aa. PLS Port - To hydraulic pump (PLS Port)
- xx. TS Port - To hydraulic tank
- Pa. PA1 Port - From L.H. PPC valve (P2 Port)
- Pb. PB1 Port - From L.H. PPC valve (P4 Port)
- Pc. PA2 Port - See hydraulic circuit
- Pd. PB2 Port - See hydraulic circuit
- Pe. PA3 Port - From ST3 solenoid valve group (A Port)
- Pf. PB3 Port - From ST3 solenoid valve group (B Port)
- Pg. PA4 Port - From R.H. PPC valve (P4 Port)
- Ph. PB4 Port - From R.H. PPC valve (P2 Port)
- Pi. PA5 Port - From L.H. PPC valve (P3 Port)
- Pj. PB5 Port - From L.H. PPC valve (P1 Port)
- Pk. PA6 Port - From R.H. PPC valve (P3 Port)
- Pl. PB6 Port - From R.H. PPC valve (P1 Port)
- Pm. PA7 Port - See hydraulic circuit
- Pn. PB7 Port - See hydraulic circuit
- Po. PA8 Port - From boom swing PPC valve (P1 Port)
- Pp. PB8 Port - From boom swing PPC valve (P2 Port)
- Pq. PA9 Port - From 2-piece boom PPC valve (P2 Port)
- Pr. PB9 Port - From 2-piece boom PPC valve (P1 Port)
- Ps. PA10 Port - From OP2 solenoid valve group (B Port)
- Pt. PB10 Port - From OP2 solenoid valve group (A Port)
- Pu. PDB Port - From PA4 Port

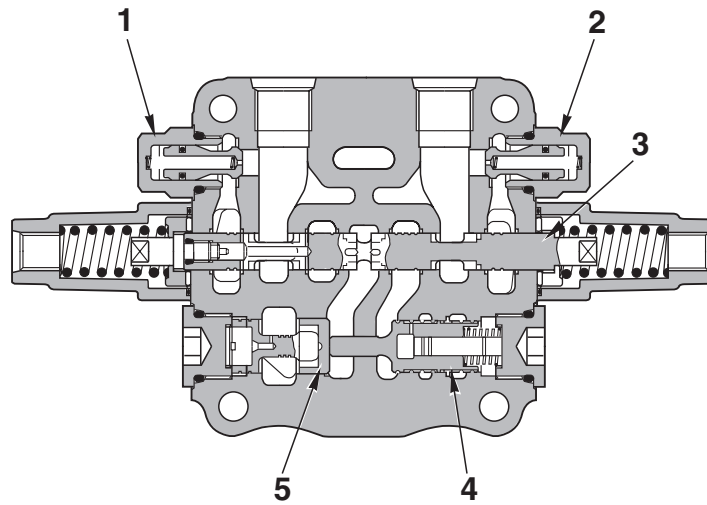

Section N-N

RKP03231

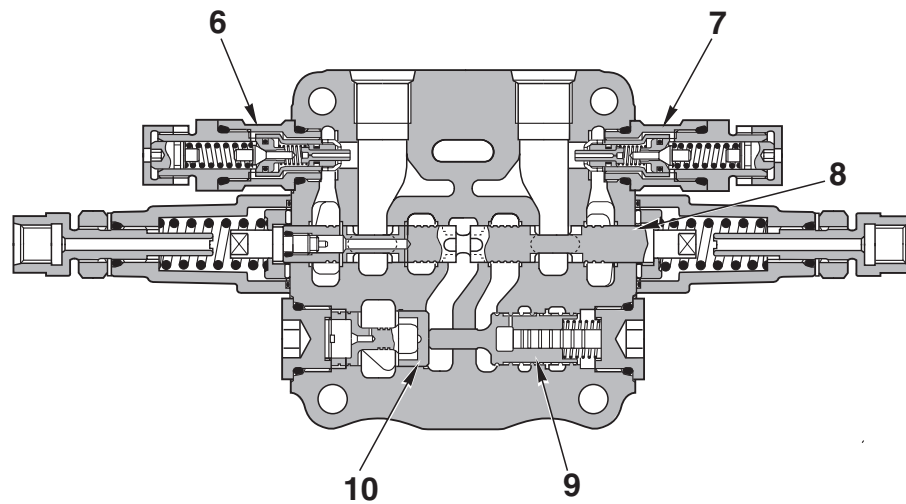

Section O-O

RKP03241

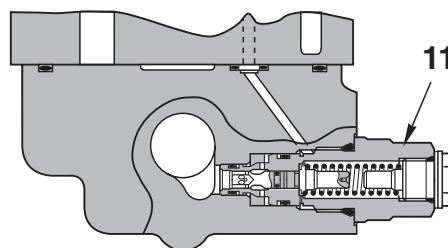

Section P-P

RKP03251

2-PIECE BOOM VALVE

- 1. Suction valve (A9 Port)
- 2. Suction valve (B9 Port)
- 3. Spool
- 4. Reducing pressure compensation valve
- 5. Flow compensation valve

ATTACHMENT VALVE

- 6. Safety valve (R.H. side)
- 7. Safety valve (L.H. side)
- 8. Spool
- 9. Reducing pressure compensation valve
- 10. Flow compensation valve
- 11. Unload valve

LS bypass plug**DESCRIPTION**

- 1 - The **LS** bypass plug releases the residual pressure of the **LS** pressure **PLS**.
- 2 - This makes the pressure-rising speed of the **LS** pressure **PLS** more gentle, and with this discarded throttled flow, it creates a pressure loss in the throttled amount of the spool or shuttle valve and increases the stability to lowering the effective **LS** differential pressure.

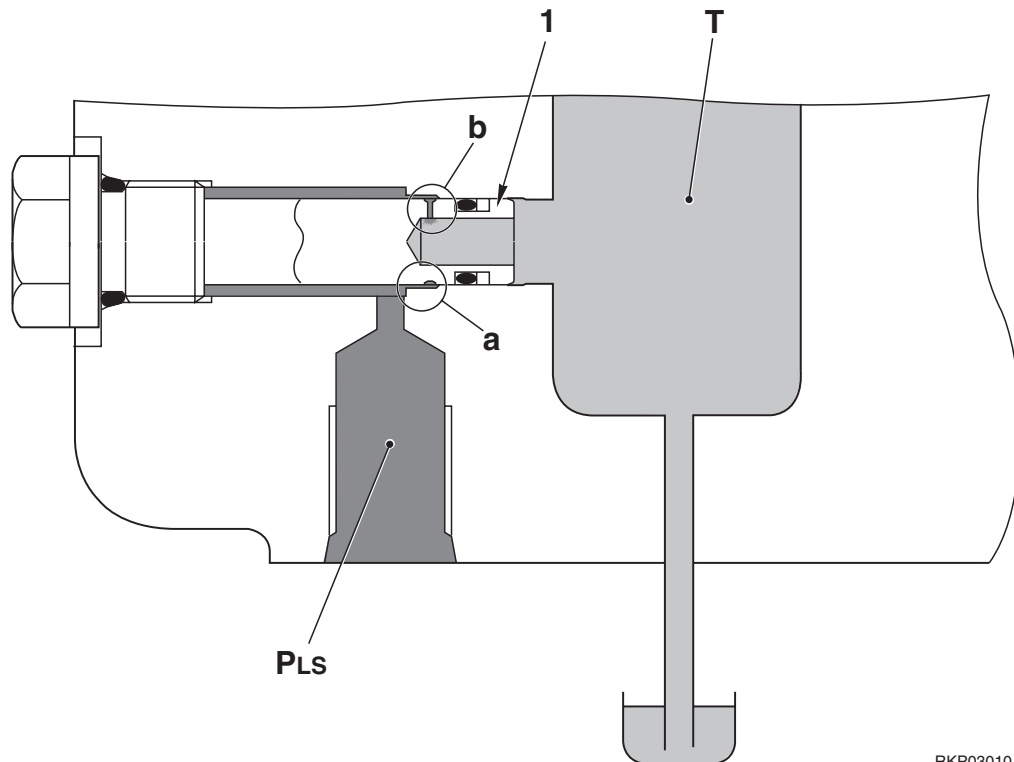

RKP03010

OPERATION

- The pressurized oil in the **LS** circuit **PLS** flows from the clearance filter **a**, which is formed by the clearance between the **LS** bypass plug (1) and the body, to the tank circuit **T** through the orifice **b**.

OPERATION OF THE MODULATING RELIEF VALVE

FUNCTION

- The relief valve for the swing motor has the properties to suppress the rapid increase of the relief pressure as per shown in the figure right, and serves to reduce the shock at the time of start and stop of swing.

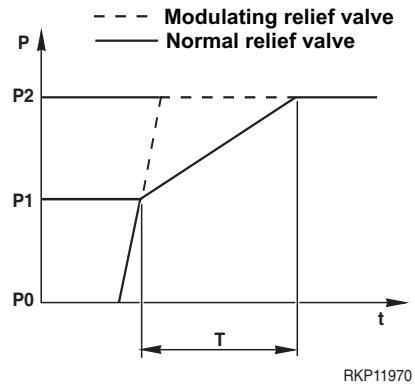

OPERATION

When the circuit pressure is P₀

- The relief valve does not operate.

When the circuit pressure has rapidly increased

- When the circuit pressure increases to **P₁**, the valve (3) starts to open because the oil pressure acts on the difference in area between **D₁** and **D₃** (**D₁>D₃**), thus pressing the spring (4).
On this occasion, the seat (1) tries to follow the valve (3) because the pressure acts on the difference in area between **D₁** and **D₂** (**D₁<D₂**).
However, the route that the oil in the chamber **a** compressed by the movement of the seat (1) can flow to the **S** port has been throttled by the ball (2), so that the movement of the seat (1) is slower than that of the valve (3).
Therefore, during the time **T** until the seat (1) makes contact with the sleeve (5), the relief pressure gradually increases from **P₁** to **P₂**

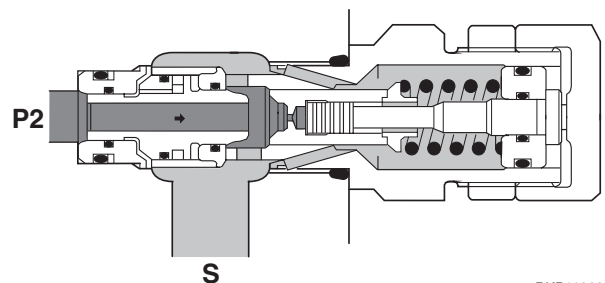
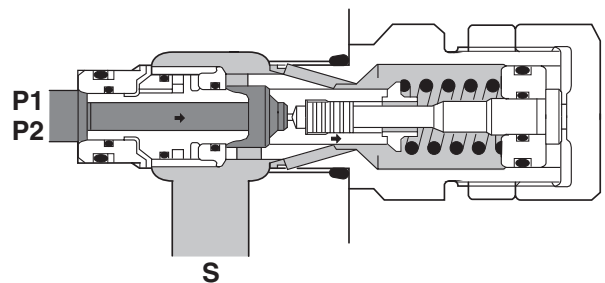
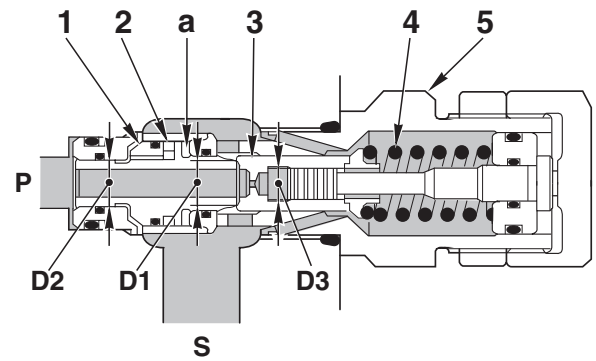

**PAGE INTENTIONALLY
LEFT BLANK**

3. During fine control (when the lever is returned)

When disc (5) starts to be returned, spool (1) is pushed up by the force of centering spring (3) and the pressure at Port **P1**.

When this happens, fine control hole **f** is connected to drain chamber **D** and the pressure oil at Port **P1** is released.

If the pressure at Port **P1** drops too far, spool (1) is pushed down by metering spring (2), and fine control hole **f** is shut off from drain chamber **D**. At almost the same time, it is connected to pump pressure chamber **PP**, and the pump pressure is supplied until the pressure at Port **P1** recovers to a pressure that corresponds to the lever position.

When the spool of the control valve returns, oil in drain chamber **D** flows in from fine control hole **f'** in the valve on the side that is not working. The oil passes through Port **P2** and enters chamber **B** to fill the chamber with oil. (Fig. 3)

4. At full stroke

When disc (5) pushes down piston (4), and retainer (7) pushes down spool (1), fine control hole **f** is shut off from drain chamber **D**, and is connected with pump pressure chamber **PP**. Therefore, the pilot pressure from the control pump passes through fine control hole **f** and flows to chamber **A** from Port **P1**, and pushes the control valve spool.

The oil returning from chamber **B** passes from Port **P2** through fine control hole **f'** and flows to drain chamber **D**. (Fig. 4).

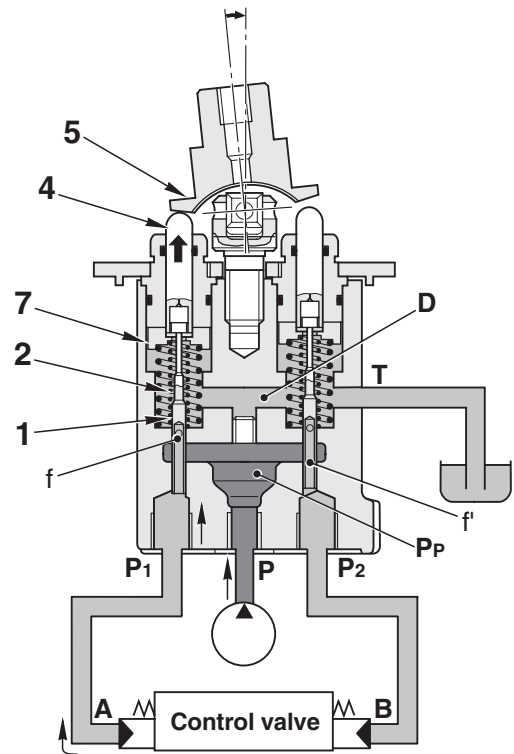

Fig. 3

RKP12861

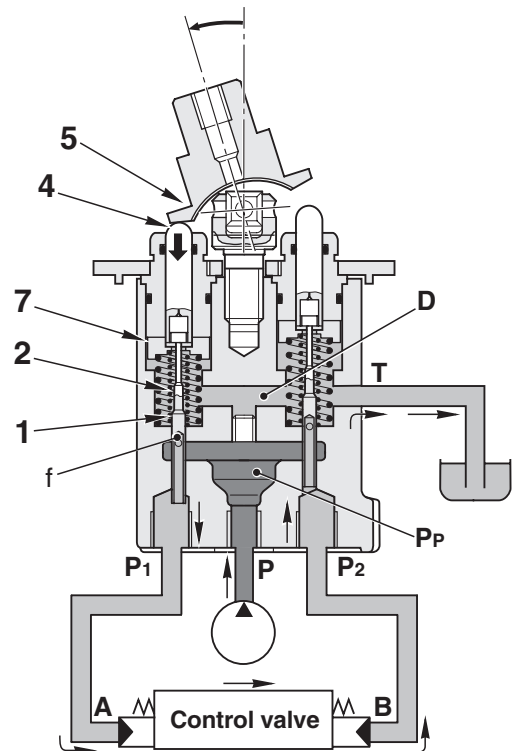
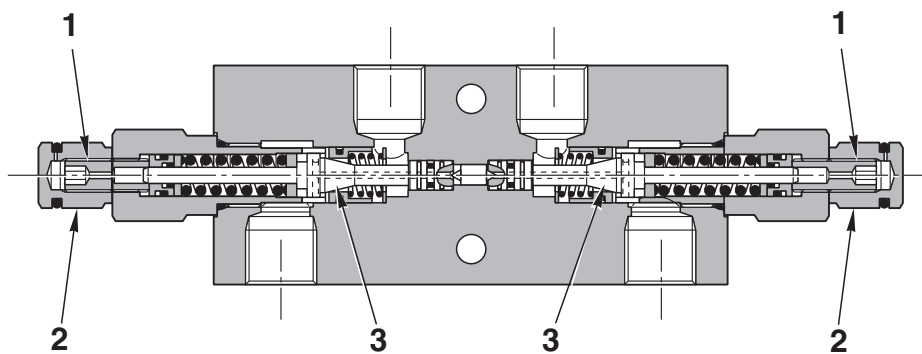
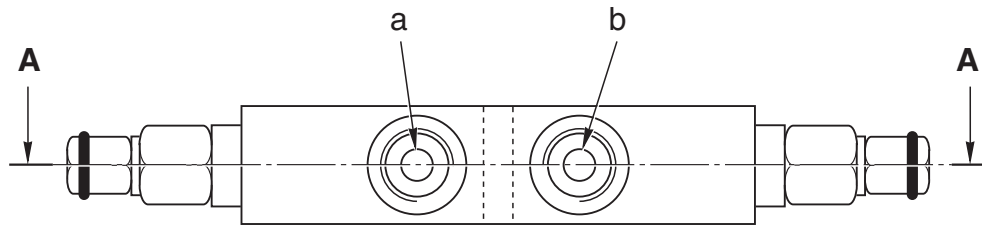

Fig. 4

RKP12871

2-PIECE BOOM SAFETY VALVE



Section A - A

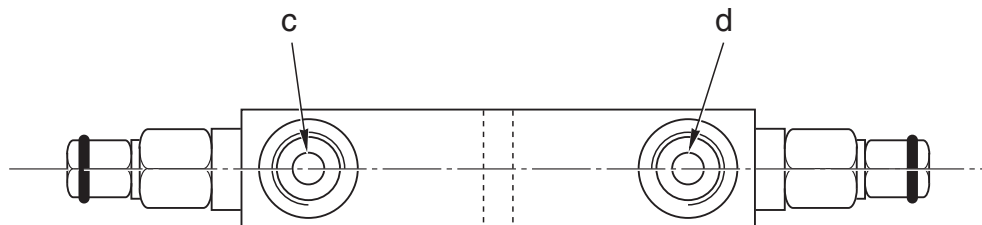

RKP04071

- 1. Screw
- 2. Plug
- 3. Valve
- a. C1 - Port To the cylinder (Head side)
- b. C2 - Port To the cylinder (Bottom side)
- c. V1 - Port From control valve (A9 Port)
- d. V2 - Port From control valve (B9 Port)

SPECIFICATIONS

Pilot ratio: 4,25 : 1

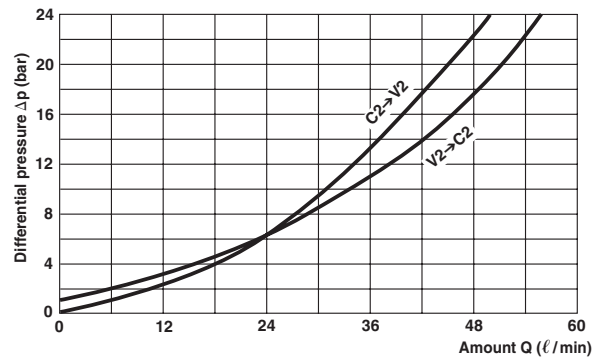

RKP04081

ELECTRICAL DIAGRAM (1/8)

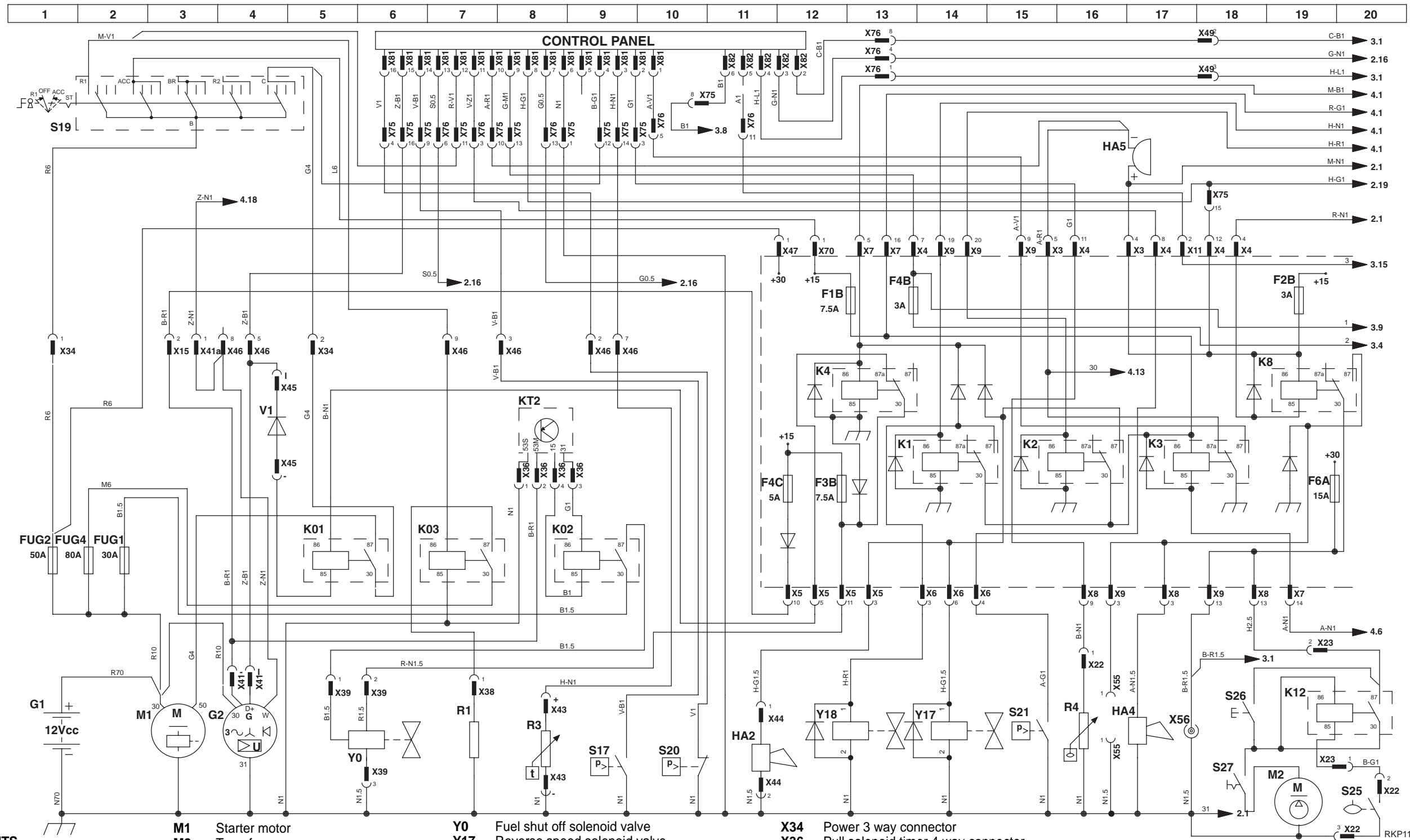

COMPONENTS

- G1 Battery
- G2 Generator
- HA2 Reverse buzzer
- HA4 Frame horn
- HA5 Buzzer
- K1 Forward speed valve relay
- K2 Reverse speed solenoid valve relay
- K3 Speed connection relay
- K4 Key safety start relay
- K8 Horn relay
- K12 Transfer pump relay
- KT2 Pull fuel solenoid timer
- M1 Starter motor
- M2 Transfer pump
- R1 Heating start
- R3 Water temperature sender
- R4 Fuel level sender
- S16 Heater switch
- S17 Air filter switch
- S19 Starting switch
- S20 Engine oil low pressure switch
- S21 Brakes less pressure switch
- S25 Fuel tank full sensor
- S26 Transfer pump start button
- S27 Transfer pump switch
- V1 Start antirepetition relay 1A diode
- X56 Current intake 12V

CONNECTORS

- X3 Right lateral dashboard line 18 way connector
- X4 Right lateral dashboard line 12 way connector
- X5 Engine line 11 way connector
- X6 Lights switch-gear shift line 13 way connector
- X7 Steering interface line 21 way connector
- X8 Loom line 21 way connector
- X9 Lights switch-gear shift line 21 way connector
- X11 Lateral dashboard line 13 way connector
- X15 Parking brakes lamp 1 way connector
- X22 Fuel level sender 3 way connector
- X23 Transfer pump 2 way connector

- X34 Power 3 way connector
- X36 Pull solenoid timer 4 way connector
- X38 Heating start 1 way connector
- X39 Fuel shut off 3 way connector
- X41 Generator 2 way connector
- X41a Frequency alternator 1 way connector
- X43 Water temperature sender 2 way connector
- X44 Back-up alarm 2 way connector
- X45 Diode 2 way connector
- X46 Dashboard wiring 9 way connector
- X47 1 way connector M6 (+30)
- X49 Diode 2 way connector
- X55 Optional horn connector 1 way connector M5 (+15)
- X70 1 way connector M5 (+15)
- X75 Dashboard extension 21 way connector

- X76 Dashboard extension 17 way connector
- X81 Control panel 16 way connector
- X82 Control panel 8 way connector

FUSES

- F1B Gear valve fuse 7.5A
- F2B Joystick -instrument power fuse 3A
- F3B Safety start- fuel shut off fuse 7.5A
- F4B Right traffic light and instrument light fuse 3A
- F4C Generator and pull timers fuse 5A
- F6A Horn-current intake-transfer pump fuse 15A
- FUG1 Fuel shut off fuse 30A
- FUG2 General fuse 50A
- FUG4 Preheating fuse 80A

ELECTRICAL DIAGRAM (6/8)

| | | | | | | | | | | | | | | | | | | | |
|---|---|---|---|---|---|---|---|---|----|----|----|----|----|----|----|----|----|----|----|
| 1 | 2 | 3 | 4 | 5 | 6 | 7 | 8 | 9 | 10 | 11 | 12 | 13 | 14 | 15 | 16 | 17 | 18 | 19 | 20 |
|---|---|---|---|---|---|---|---|---|----|----|----|----|----|----|----|----|----|----|----|

X73

| POS | DESCRIZIONE FUNZIONE | FUNCTION DESCRIPTION |
|-----|-------------------------------|------------------------------------|
| 1 | MASSA | GROUND |
| 2 | ALIMENTAZIONE SCHEDA/PULS. | PANEL POWER SUPPLY |
| 3 | | |
| 4 | PULSANTE AVV. ACUSTICO | HORN BUTTON |
| 5 | OUT PULS. FRENO PARCHEGGIO | OUT BUTTON PARKING BRAKE |
| 6 | INTERR. STERZATURA TONDO | ROUND STEERING SWITCH |
| 7 | INTERR. 2 RUOTE STERZANTI | 2 WHEEL STEERING SWITCH |
| 8 | INTERR. STERZATURA GRANCHIO | CRAB STEERING SWITCH |
| 9 | OUT E/V BENNA | GRAB VALVE OUT SIGNAL |
| 10 | OUT E/V MARTELLO | HAMMER VALVE OUT SIGNAL |
| 11 | ALIMENTAZIONE RELE' | RELAIS POWER SUPPLY |
| 12 | N.C. | N.C. |
| 13 | N.C. | N.C. |
| 14 | OPTIONAL | OPTIONAL |
| 15 | RELE' PINZA | PLIERS RELAY |
| 16 | OUT E/V BLOCCO ASSALE | AXLE LOCK VALVE OUT SIGNAL |
| 17 | OUT E/V WORKING MODE | WORKING MODE VALVE OUT SIGNAL |
| 18 | OUT E/V STABILIZZATORI / LAMA | STABILIZER, BLADE VALVE OUT SIGNAL |

X72

| POS | DESCRIZIONE FUNZIONE | FUNCTION DESCRIPTION |
|-----|---------------------------------|---|
| 1 | ALLINEAMENTO POSTERIORE | REAR ALIGNMENT |
| 2 | ALLINEAMENTO ANTERIORE | FRONT ALIGNMENT |
| 3 | SEGNALE PRESS. ANTIRIBALTAMENTO | ANTI OVERTURNING PRESSURE SWITCH SIGNAL |
| 4 | N.C. | N.C. |
| 5 | N.C. | N.C. |
| 6 | PULSANTE PEDALE MARTELLO | HAMMER PEDAL BUTTON |
| 7 | PULSANTE PINZA | PLIERS BUTTON |
| 8 | PULS. MARTELLO O CHIUDI BENNA | HAMMER OR CLOSE GRAB BUTTON |
| 9 | PULSANTE APRI BENNA | OPEN GRAB BUTTON |
| 10 | N.C. | N.C. |
| 11 | ALIMENTAZIONE RELE' | RELAIS POWER SUPPLY |
| 12 | OUT E/V FRENO DI PARCHEGGIO | PARKING BRAKE VALVE OUT SIGNAL |

X79

| POS | DESCRIZIONE FUNZIONE | FUNCTION DESCRIPTION |
|-----|------------------------------|---------------------------|
| 1 | OUT SPIA FRENO DI PARCHEGGIO | OUT PARKING BRAKE LAMP |
| 2 | N.C. | N.C. |
| 3 | OUT SPIA BLOCCO ASSALE | OUT AXLE LOCK LAMP |
| 4 | OUT SPIA PALA/STABILIZZATORI | OUT BLADE STABILIZER LAMP |
| 5 | +COMUNE PULSANTI E SPIE | +COMMON SWITCH AND LAMP |
| 6 | PULSANTE FRENO DI PARCHEGGIO | PARKING BRAKE BUTTON |
| 7 | N.C. | N.C. |
| 8 | PULSANTE PALA/STABILIZZATORI | BLADE/STABILIZER BUTTON |
| 9 | PULSANTE BLOCCO ASSALE | AXLE LOCK BUTTON |



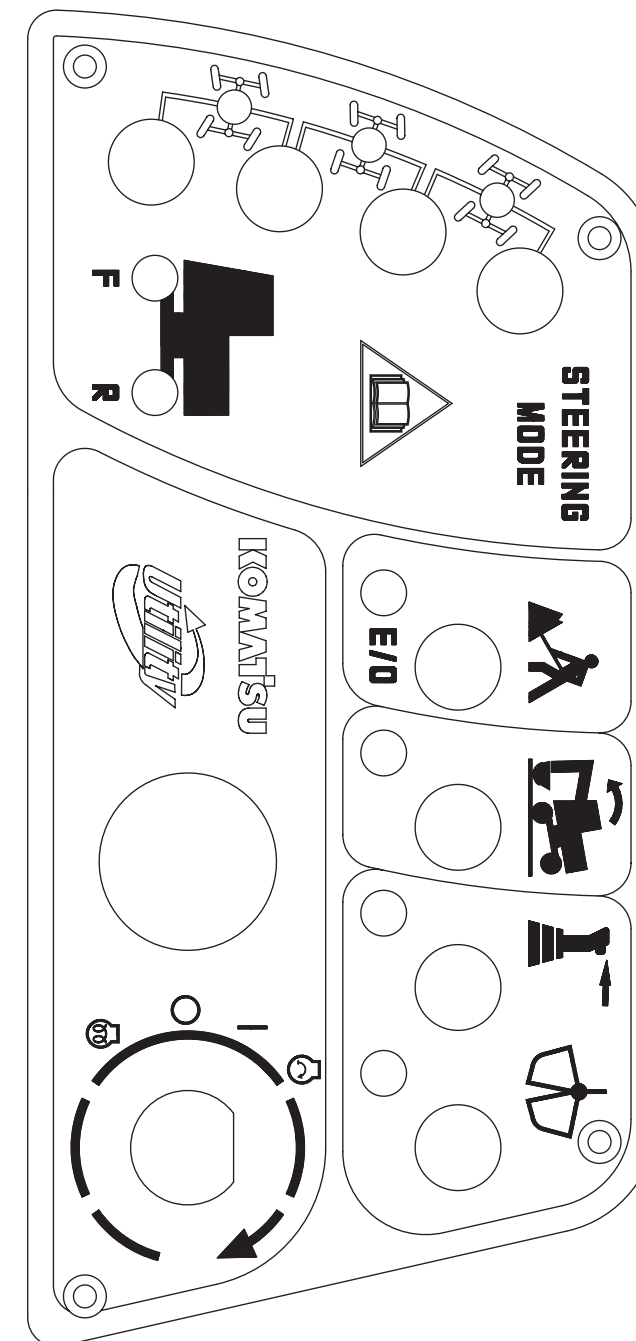

PULSANTIERA PRINCIPALE MAIN SWITCHES PANEL



RKP11750

20 TESTING AND ADJUSTMENTS

| | | | |
|---|----|--|----|
| Normal or standard technical data..... | 2 | Checking and regulating the pressure of the steering system | 41 |
| Special tools | 16 | Checking leakages in the steering cylinders | 42 |
| Measuring the engine speed | 17 | Checking the braking system | 43 |
| Adjusting valve clearance | 18 | Checking wear in the brake disks..... | 48 |
| Measuring compression pressure | 19 | Bleeding air from the brake lines..... | 49 |
| Testing and adjusting fuel injection timing..... | 20 | Adjusting the parking brake..... | 50 |
| Testing and adjusting fan belt tension | 22 | Travel hydraulic equipment checking procedure..... | 51 |
| Checking and tightening the compressor fan-belt ... | 23 | Checking and adjusting the automatic displacement control system of the travel motor | 52 |
| Adjusting the stroke of the accelerator lever | 24 | Checking for leakages in the travel motor | 53 |
| Adjusting PPC valves clearance..... | 25 | Checking and adjusting the speed of the travel propeller shaft..... | 54 |
| Adjusting the safety microswitch | 26 | Adjustment of the speed surveyor | 55 |
| Measuring the swing circle axial clearance | 27 | Adjusting boom and arm safety valves..... | 56 |
| Air bleeding from hydraulic circuits..... | 28 | Adjusting 2nd boom safety valves..... | 57 |
| Releasing residual pressure from the circuits..... | 31 | Measuring and setting of pressure switch signal overload operation | 58 |
| Checking and regulating pressure in the hydraulic circuits | 32 | Measurement of internal oil leakages in the swing motor | 59 |
| Testing and setting of main valves | 33 | Checking for leakages inside the swivel joint | 60 |
| Adjusting PC valve | 35 | Analysis of the causes of hydraulic drifts | 63 |
| Measuring Is differential pressure and adjusting LS valve | 36 | Testing the air-conditioning unit | 73 |
| Checking and adjusting pressures in the servocontrol feed unit | 38 | Emptying the air-conditioning unit | 75 |
| Measuring pumps delivery and flow control starting point pump P1..... | 39 | | |
| Checking that the priority valve is functioning correctly..... | 40 | | |

-  When carrying out controls, adjustments or analyses for troubleshooting, park the machine on firm, level ground. Apply all the machine safety devices and use blocks to prevent any machine movement.
-  When more than one person is engaged in the work, use the prescribed notices that indicate that the machine is undergoing maintenance. Do not allow any unauthorised persons to remain in the vicinity.
-  When checking the level of the cooling liquid, wait until this liquid has cooled. If the radiator cap is removed while the liquid is still hot and under pressure, it may cause severe burns.
-  Take great care not to get entangled in moving parts (fan, alternator belt or any of the rotating elements).

FOR MACHINE

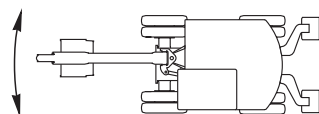
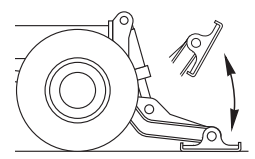
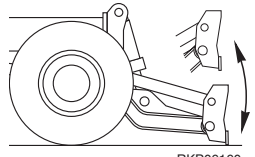
| Machine model | | | | PW95R-2 | | |
|--|---|---|--------------------|-------------------|-------------------------------------|----------|
| Classifi- cation | Check item | Test conditions | Unit | Standard value | Permissible value | |
| Attrezzature di lavoro Velocità | Boom swing Cylinder completely retracted ↕ Cylinders completely extended | Measuring posture  RKP06140 • Work equipment at max. reach • Working Mode: P • Engine speed: high idling • Oil temperature: 45–55 °C | L.H. R.H. | sec. | 6.0±0.6 | Max. 7.0 |
| | Outriggers Resting on ground ↕ Fully raised | Measuring posture  RKP06150 • Working Mode: P • Engine speed: high idling • Oil temperature: 45–55 °C | Raise Lower | | 2.5 ^{-0.1} _{+0.5} | Max. 3.5 |
| | Blade Blade on the ground ↕ Blade raised to max. height | Measuring posture  RKP06160 • Working Mode: P • Engine speed: high idling • Oil temperature: 45–55 °C | Raise Lower | | 2.5 ^{-0.1} _{+0.5} | Max. 3.5 |
| | | | | | 2.6 ^{-0.2} _{+0.4} | Max. 3.5 |
| | | | | | 2.6 ^{-0.2} _{+0.4} | Max. 3.5 |
| | | | | | 2.6 ^{-0.2} _{+0.4} | Max. 3.5 |

5 - Check notch (4) position on crankshaft pulley (1) compared with scale (5); reading value corresponds to angle of fuel injection timing.

★ With new belt, deflection must be of $11^{\circ} \pm 1^{\circ}$

NOTE. Repeat checking more than once.

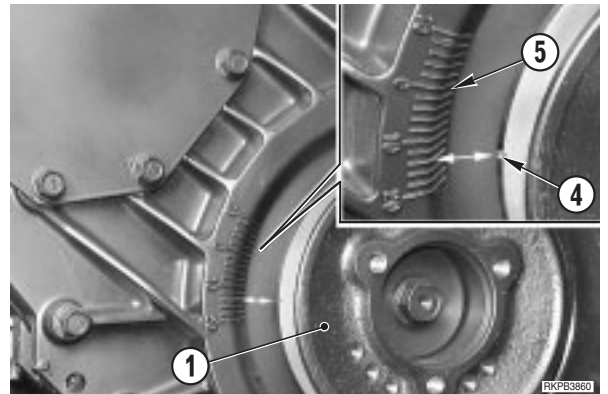

6 - If injection timing is not on standard value, rotate injection pump (6) toward external or toward engine after loosening pump nuts (7) (quantity 4) and pump lock nuts (8) fixing the bracket (9) to injection pump.

- To RETARD injection, rotate the pump (6) toward external.
- To ADVANCE injection, rotate the pump (6) toward cylinders block.

7 - Tight the pump lock nuts (7) at cylinder block and the nut (8) fixing injection pump to bracket (9).

 Nuts: 34.2–44.1 Nm

 Bracket nut: 44.1–53.9 Nm

8 - Connect fuel delivery pipes (2) to pump.

 Delivery pipe unions: 19.6–24.5 Nm

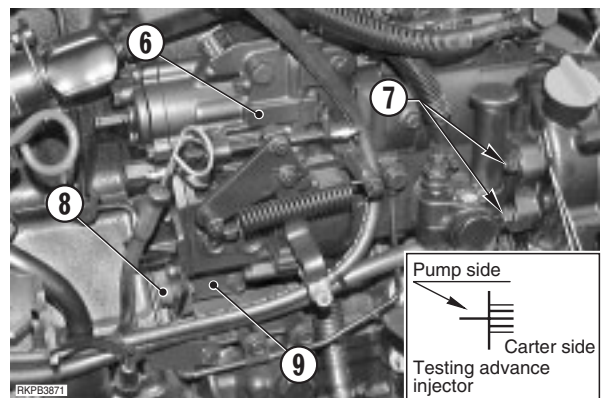

RELEASING RESIDUAL PRESSURE FROM THE CIRCUITS

- 1 - Rest the work equipment on the ground and stop the engine.
- 2 - Put the ignition key at position "I" and move the control lever in all directions to relieve all pressure in the main hydraulic circuits and the PPC valves.
- 3 - Turn the ignition key to position "O" (OFF) and remove it.
- 4 - Put the lever of the safety device into the «LOCKED» position.
- 5 - Slowly loosen the oil-tank filler-cap to release any residual pressure.

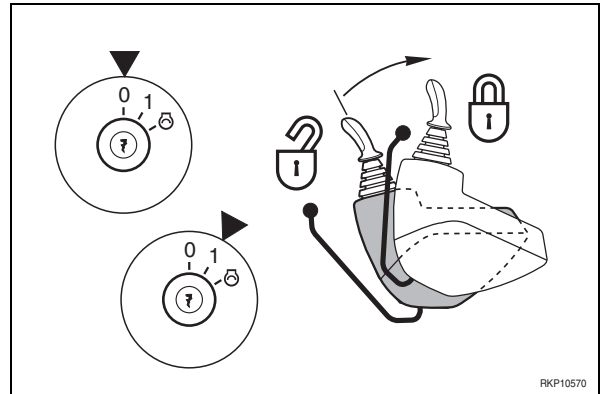

2. From the brake line accumulators

- 1 - Rest the work equipment on the ground and stop the engine.
- 2 - Turn the ignition key to position "I".
- 3 - Push the button that engages the working brakes several times until the accumulators are completely emptied. This condition has been achieved when the brake pedal will no longer move.
- 4 - Return the ignition key to position "O" (OFF).

CHECKING AND REGULATING THE PRESSURE OF THE STEERING SYSTEM

★ Test conditions:

- Engine: at working temperature
- Hydraulic oil: 45–55°C

Test

- 1 - Connect pressure gauge **E3** (400 bar) to the adapter **M2**.
- 2 - Start the engine and put it into high idling and turn the steering wheel as far as it will go.
- 3 - Apply extra force to the steering wheel in its fully turned position.
 - ★ Normal pressure: 170±10 bar
- 4 - Repeat this check while steering in the other direction.

Adjustment

If the pressure is not within permissible limits, it can be adjusted from the safety valve (1) of the steering unit (2).

- 1 - Remove the cap (3).
- 2 - Using a 4 mm screw wrench, adjust the maximum pressure through the screw (4).
 - To INCREASE pressure turn in a CLOCKWISE direction.
 - To DECREASE pressure, turn in a COUNTER-CLOCKWISE direction.
- 3 - Stop the engine and replace the cap (3), making sure that the washer (5) is properly seated.

 Cap: 50±10 Nm

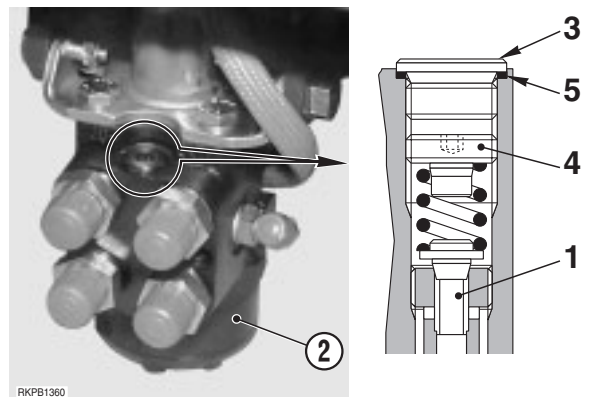
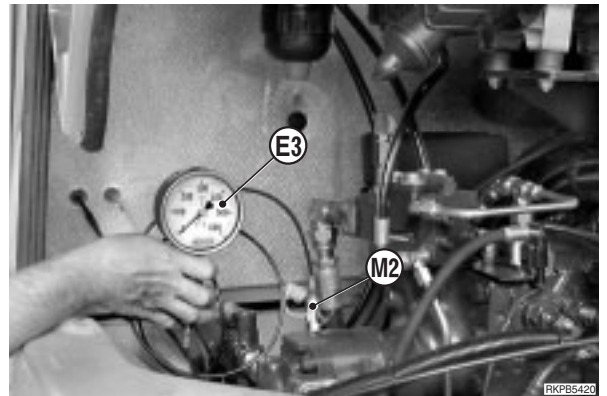

TRAVEL HYDRAULIC EQUIPMENT CHECKING PROCEDURE

★ Check conditions:

- Engine: at working temperature
- Hydraulic oil: 45–55 °C
- Service brakes: on

This test is divided into two sections to facilitate identification of the faulty member or part that is to be set.

1. Top portion of the equipment

Check that:

- Servocontrol pressure is normal (for details, see «CHECKING AND ADJUSTING PRESSURES IN THE SERVOCONTROL FEED UNIT»).
- That spools receive pressure from servocontrol.
- The distributor spool involved in travel executes the whole travel (See «TECHNICAL DATA»).
- The valve in section 1 of the distributor is set. (For details, see «TESTING AND SETTING OF MAIN VALVES»).
- The pressure of differential unit ΔPLS of the LS is normal (For details, see «MEASURING LS DIFFERENTIAL PRESSURE AND ADJUSTING LS VALVE»).
- There is no internal blow-by in the swing joint (for details, see «CHECKING FOR LEAKAGES INSIDE THE SWIVEL JOINT»).
- The safety valves of the travel motor are set (320 ± 10 bar, bench controlled).

2. Bottom part of the equipment

Check:

- The operating point of the travel motor automatic displacement change device.
For details, see «CHECKING AND ADJUSTING THE AUTOMATIC DISPLACEMENT CONTROL SYSTEM OF THE TRAVEL MOTOR»).
- Blow-by in the travel motor.
For details, see «CHECKING FOR LEAKAGES IN THE TRAVEL MOTOR».

| N° | Branch to be tested (under pressure) | Adjacent parts (Leakages) | N° |
|----|--------------------------------------|------------------------------------|----|
| 5 | Fast gear insertion | Blade-outrigger command (Rise) | 6 |
| | | Parking brake | 4 |
| 4 | Parking brake | Fast gear insertion | 5 |
| | | Drainage (travel motor and EV OP2) | 3 |
| 3 | Drainage (travel motor and EV OP2) | Parking brake | 4 |
| | | Front steering to the left | 2 |
| 2 | Front steering to the left | Drainage (travel motor and EV OP2) | 3 |
| | | Front steering to the right | 1 |
| 1 | Front steering to the right | Front steering to the left | 2 |
| | | External leakage (Visible) | - |

! The numbers correspond to the numbers stamped on the input and output ports of the swivel joint.

3. Preparation for testing:

- **travel motors**
- **travel brakes**
- **speed increment**

- 1 - Relieve all residual hydraulic pressures (See «RELEASING RESIDUAL PRESSURES FROM THE CIRCUITS»).
- 2 - Identify the branch involved in the test (1).
- 3 - Disconnect the hoses (2) from the branches adjacent to the part to be tested and cap them tightly.

! Make sure that the detached tubes are securely sealed, to prevent jets of high-pressure oil escaping if circuits that are not undergoing tests should accidentally become pressurised.

★ The tubes of the adjacent branches must be disconnected from the upper parts of the swivel joint.

- 4 - Provisional hoses (3) for collecting any oil leakages should be connected to the inlets of the branches adjacent to the one being tested.

4. Preparation for testing the blade

- 1 - Relieve all residual hydraulic pressures (See «RELEASING RESIDUAL PRESSURES FROM THE CIRCUITS»).
- 2 - Identify the branch involved in the test.
- 3 - Disconnect the tube corresponding to the branch to be tested from the safety valve input and cap it.

! Make sure that the detached tubes are securely sealed, to prevent the escape of jets of oil at high pressure.

- 4 - Cap the valve to prevent entry of impurities.
- 5 - Disconnect from the swivel joint the hoses (2) of the branches adjacent to the branch to be tested, and cap them tightly.

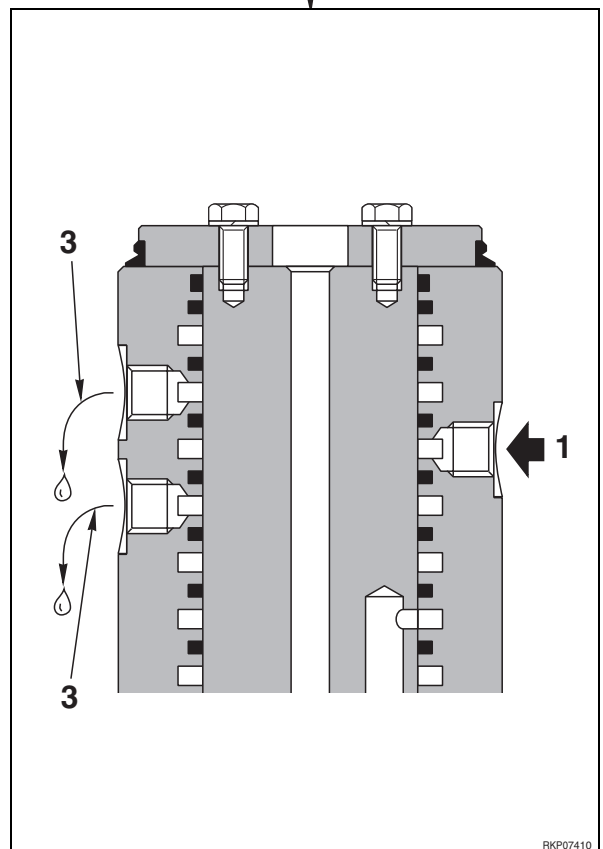
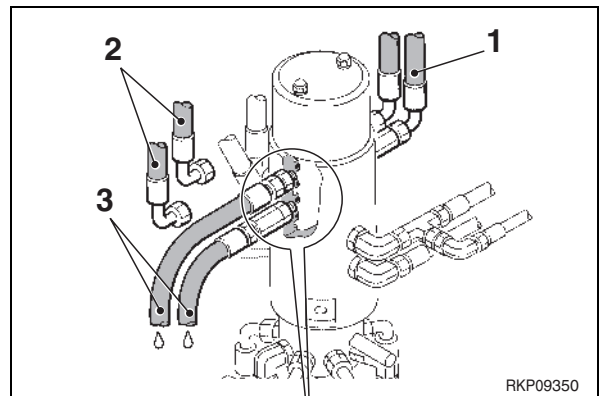

11. Checking the travel motor

- 1 - Position the machine with the arm vertical and the back of the bucket resting on the ground. Stop the engine.
- 2 - Disconnect the supply tube (2) from the parking brake (1).
- 3 - Insert the cock "A" between the brake (1) and the tube (2).
Attach the pressure gauge E1 (60 bar) to the adapter of cock "A". to keep a check on the parking brake release pressure throughout the test.
- 4 - With the cock "A" open, start the engine and engage and release the parking brake several times.
- 5 - Raise the front work equipment and travel the machine over a surface with a 15° slope.
★ The articulated axle should be facing towards the lower part of the slope.
- 6 - Using the working brakes to hold the machine in position, close the cock "A". in order to maintain pressure (35 ± 3.5 bar) and thus to keep the parking brake released.
Stop the engine.
- 7 - After 5 minutes, mark the position of the machine.
- 8 - Check whether or not the machine has moved every 5 minutes for a total of 15 minutes.
★ During this test the pressure indicated on the pressure gauge E1 should not drop below a minimum limit of 22 bar.

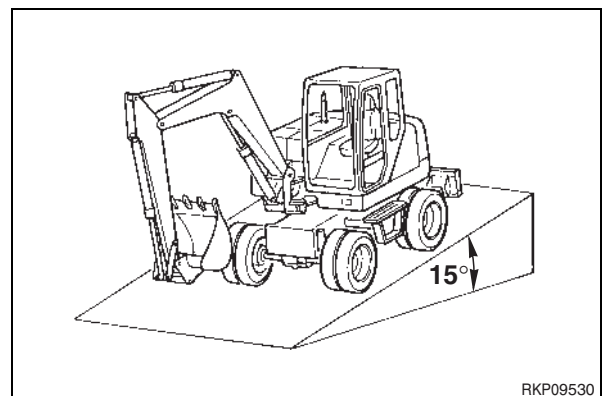
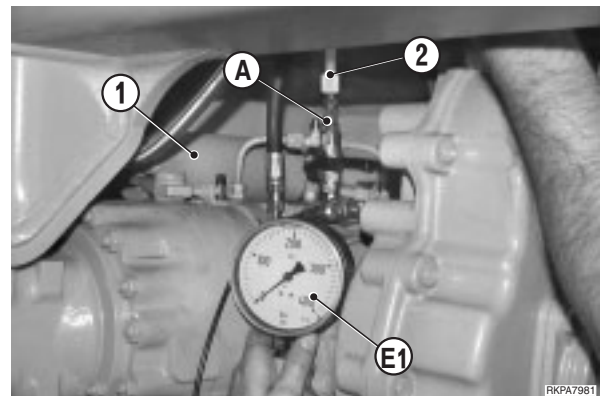
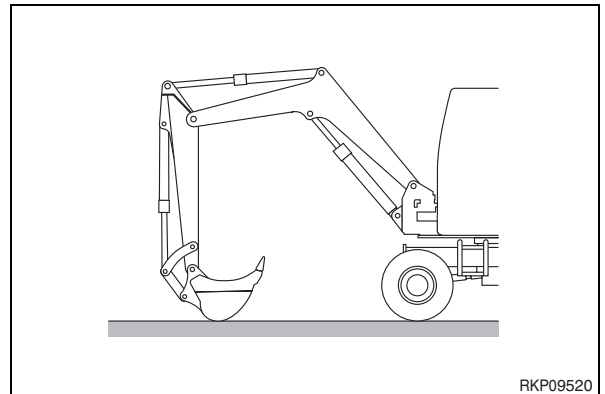

SPECIAL TOOLS

| Nature of work | Symbol | | Code | Description | Q.ty | Notes |
|---|--------|---------|------------------------|-------------------------------------|------|---|
| Removal/Installation of counterweight Disassembly/Assembly of cylinder nut | A | 1 | Commercially available | Dynamometric wrench with multiplier | 1 | Max. 700 kgm (700 dNm) |
| Disassembly/Assembly of swing machinery | C | 1 | | Wrench | 1 | Te remove and mount lock-nut |
| | | 2 | | Plunger | 3 | To remove inside ring from pinion bearing |
| | | 3 | | Plunger | 1 | To assemble inside bearing ring |
| | | 4 | | Plunger | 1 | To mount outside bearing ring |
| Air conditioning unit | D | 1 | Commercially available | Maintenance station | 1 | – |
| Disassembly/Assembly axles | M | 1 | – | Wrench | 1 | – |
| | | 2 | – | Tool | 1 | Removal/installation of differential planetary wheel pins |
| | | 3 | – | Bushing | 1 | |
| | | 4 | – | Tool | 1 | Installation of differential planetary wheel pins |
| | | 5 | – | Wrench | 1 | Flange locking |
| | | | – | Wrench | 1 | |
| | | 6 | – | Wrench | 1 | Flange ring nut locking |
| | | 7 | – | Wrench | 1 | Pinion locking |
| | | 8 | – | Block | 1 | – |
| | | 9 | – | Spacer | 1 | – |
| | | 10 | – | Bearing inner ring installation kit | 1 | Installation pinion bearing |
| | | | – | | 1 | |
| | | | – | | 1 | |
| | | 11 | – | Tool | 1 | Pinion dimension measuring |
| | | 12 | – | Bearing outer ring installation kit | 1 | Installation pinion bearing |
| | | 13 | – | Wrench | 1 | Pinion torque measuring |
| | | 14 | –0 | Plunger | 1 | |
| 15 | – | Plunger | 1 | | | |
| 16 | – | Tool | 1 | Arm alignment | | |
| 17 | – | Bush | 1 | | | |

CLICK HERE TO **DOWNLOAD** THE COMPLETE MANUAL

- Thank you very much for reading the preview of the manual.
- You can download the complete manual from: www.heydownloads.com by clicking the link below



- Please note: If there is no response to CLICKING the link, please download this PDF first and then click on it.

CLICK HERE TO **DOWNLOAD** THE COMPLETE MANUAL

REMOVAL AND INSTALLATION

REMOVAL OF STARTER MOTOR

! Disconnect the cable from accumulator negative terminal (-).

1 - Remove lower guard.

2 - Disconnect electrical cable (1).

3 - Remove screw (2) and starter motor (3).

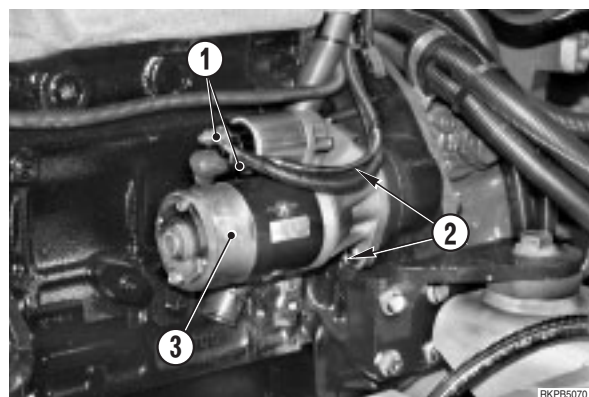

INSTALLATION OF STARTER MOTOR

- To install, reverse the removal procedure.



Screws: 78.4–98 Nm

REMOVAL OF THE MUFFLER

! Disconnect the cable from accumulator negative terminal (-).

1 - Remove the cover (1) (No. 5 screws) together with the exhaust pipe (2).

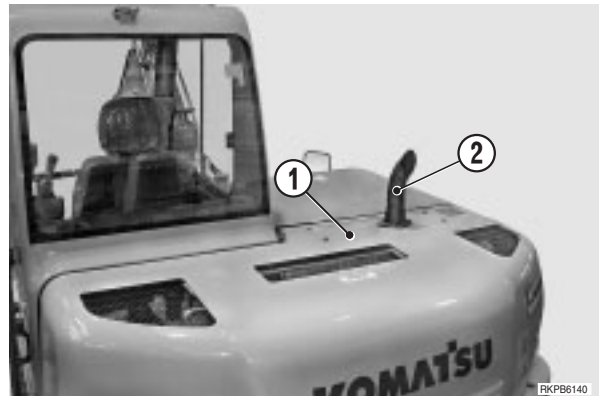

2 - Loosen the nuts (3), nut (4) and remove the exhaust pipe (5) and bracket (6).

3 - Loosen screws (7) and (8) and remove protection (9) from L.H. side.

★ Pay attention not to drop the engine-hoisting lug (10).

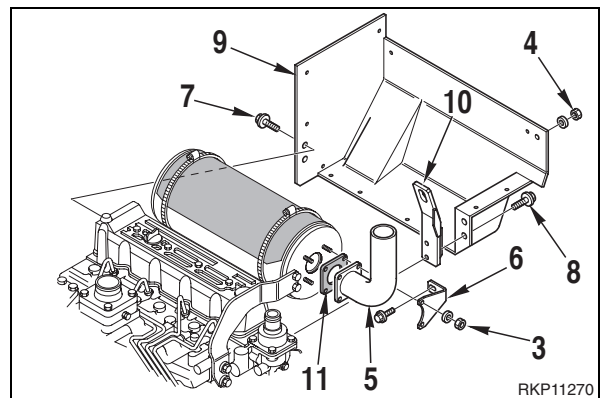

4 - Loosen screws (12), two nuts (13) and screw (14).

5 - Loosen nuts (15) and remove muffer (16) from L.H. side.

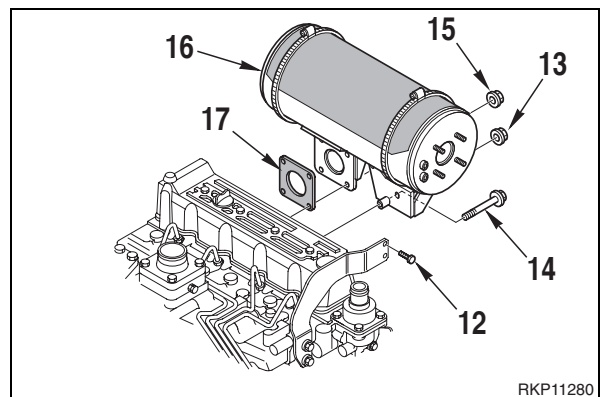



INSTALLATION OF THE MUFFLER

• To install, reverse the removal procedure.

★ Replace the sealing gasket (11) and (17).

 Nuts (14): 46±2 Nm

 Screw (13): 27±2 Nm

 Nuts (12): 27±2 Nm

 Screws (11): 27±2 Nm

 Screws (8): 46±2 Nm

REMOVAL OF CONDENSER UNIT

(Only for machine equipped with an air conditioning unit)

! Disconnect the cable from accumulator negative terminal (-).

! Lower the work equipment until it is resting on the ground and switch off the engine.

1 - Connect the outlets (1) and (2) to the maintenance station for air-conditioning units **D1** and drain the cooling fluid.

 Quantity of fluid R134a: 1100 ⁻³⁰ ₊₅₀ g

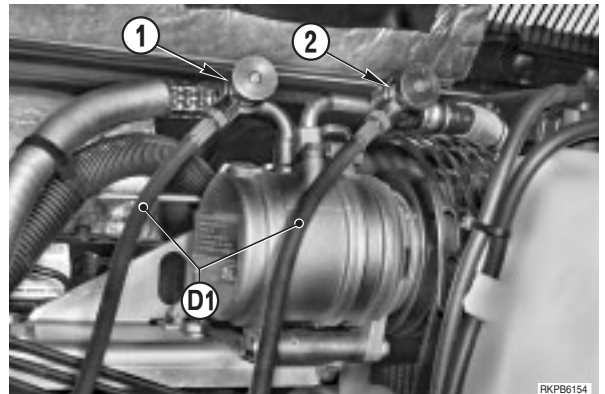

2 - Loosen the knobs (3) and remove the hood (4).

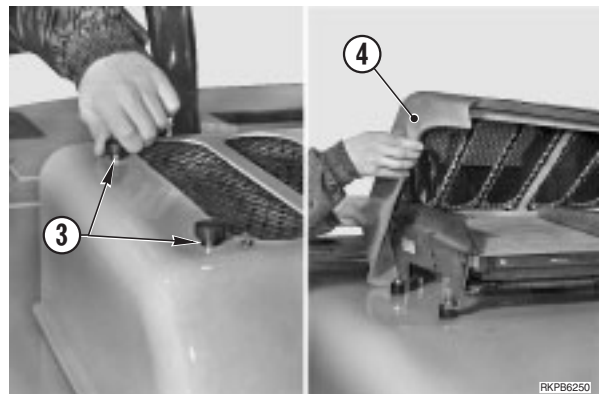

3 - Disconnect pipes (6) and (7) from condenser unit (5).

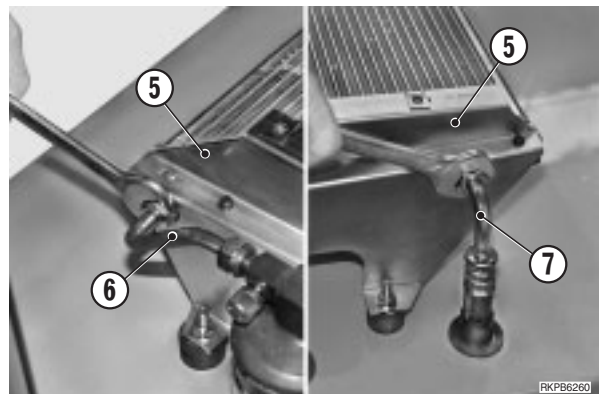

4 - Disconnect pipes (6) and (9) from filter (8).

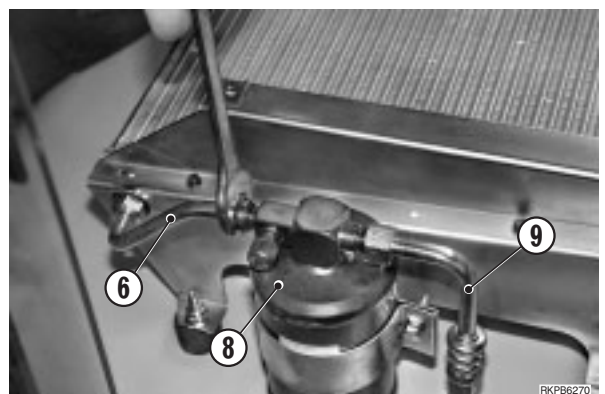

REMOVAL OF FUEL TANK

⚠ Lower the work equipment until it is resting on the ground and switch off the engine.

⚠ Disconnect the cable from accumulator negative terminal (-).

★ Turn the turret 45° towards the right.

1 - Remove the front hood (for details, see «REMOVAL OF FRONT HOOD») and the bottom right guard of the turret.

2 - Remove the cap (1) of the fuel tank (2), open the tank drainage cock (3), and drain the fuel.

3 - Disconnect the fuel suction pipe (4).

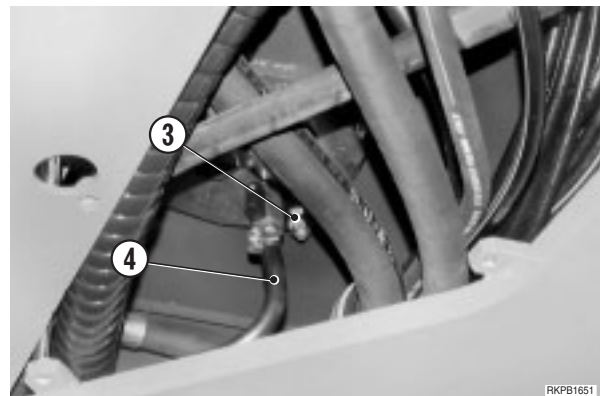

4 - Disconnect the fuel return pipe (5) and the connector (6) of the level gauge (7).

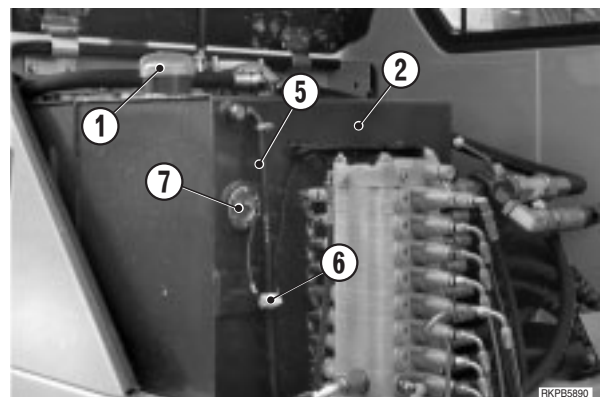

5 - Disconnect the plate (8) that joins the tanks.

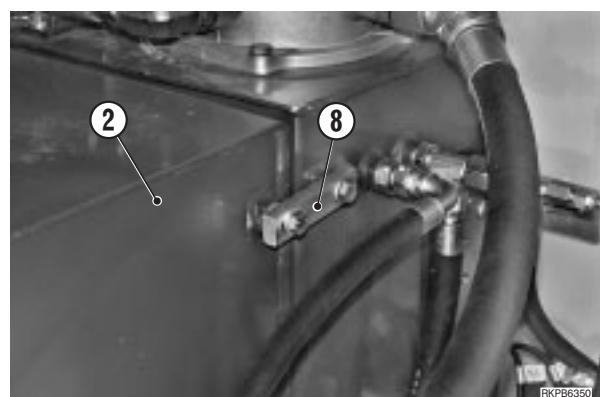

REMOVAL OF SWING MOTOR

⚠ Lower the work equipment until it is resting on the ground and switch off the engine.

⚠ Release residual pressures from all circuits. (For details, see «20. TESTING AND ADJUSTMENTS»).

1 - Disconnect the supply (1), return (2), the brake release pipe (3) and the drain line connection (4). **⊗ 1**

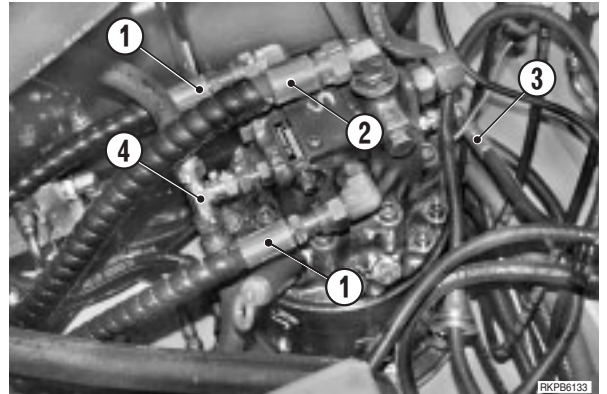

2 - Remove the screws (5) and remove the motor (6).

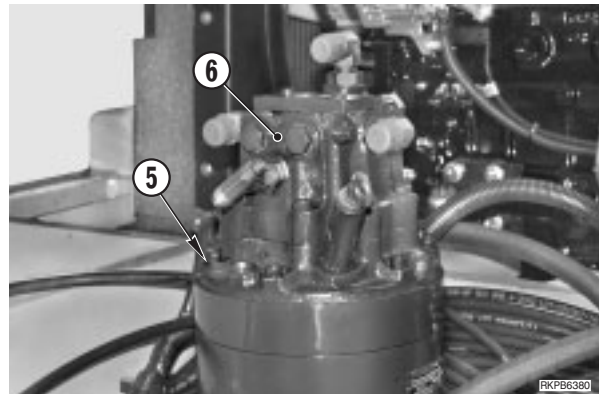

INSTALLATION OF SWING MOTOR

- To install, reverse the removal procedure.

⊗ 1

★ Fill the motor with hydraulic oil through the top drain line connection.

1 - Start the engine to allow oil circulation in all systems and check the seals.

2 - Bleed the air from engine. (For details, see «20. TESTING AND ADJUSTMENTS»).

8 - Mount the sealing ring (21) in the gearbox housing (4).

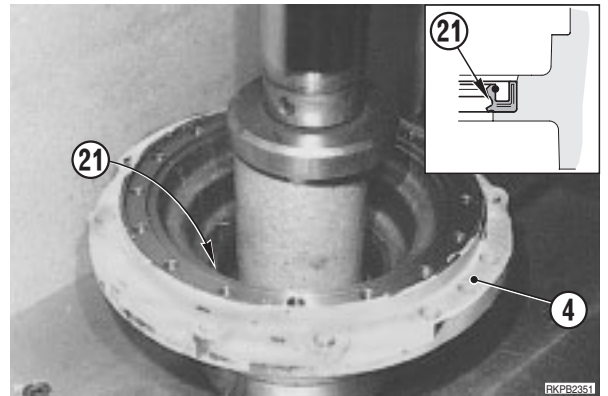

9 - Fill with grease the bearing (22) seat.

 Bearing: ASL800050

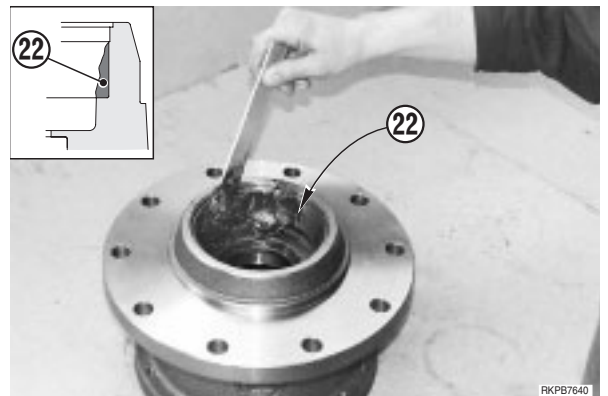

10 - Position the gearbox housing (4) over the swing pinion (15).

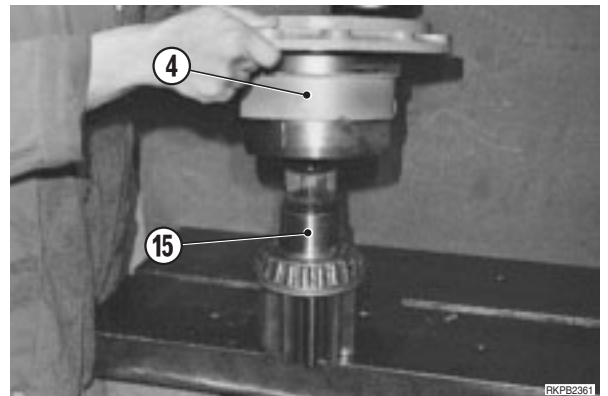

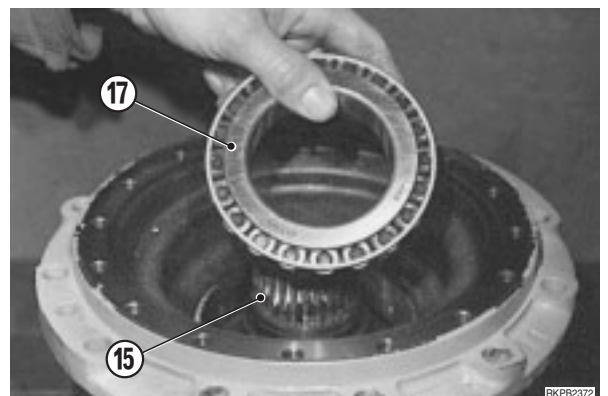

11 - Mount the inside bearing ring (17) on the swing pinion (15).

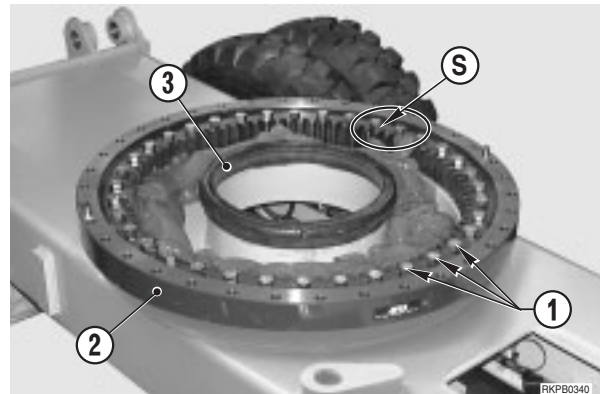

REMOVAL OF SWING CIRCLE

- 1 - Remove the upper revolving frame. (For details, see «REMOVAL OF UPPER REVOLVING FRAME»).
- 2 - Completely remove all contaminated grease.
- 3 - Remove the screws (1) that secure the swing circle (2).



- 4 - Remove the swing circle (2) using a lifting equipment "A". 

 Swing circle: 124 kg

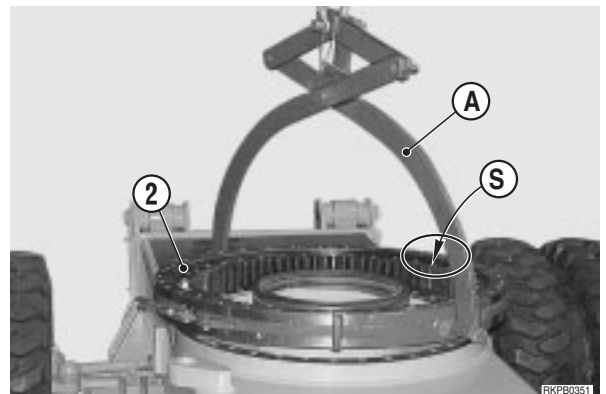

INSTALLATION OF SWING CIRCLE

- ★ Before installing the swing circle, check the condition of the central gasket (3).
-  For reasons of safety, when installing the swing circle, insert two screws into the front and back holes in the frame.
- To install, reverse the removal procedure.



Before attaching the swing circle, check that the area marked with an «S» is positioned on the right-hand side of the chassis.

 Attachment screws: Loctite 242

 Lubricating grease: approx. 25 kg

REMOVAL OF THE STEERING UNIT

! Lower the work equipment until it is resting on the ground and stop the engine.

! Release all residual pressures from all circuits.
 † (For details, see «20. TESTING AND ADJUSTMENTS»).

1 - Remove the LH guard (1) of the revolving frame.

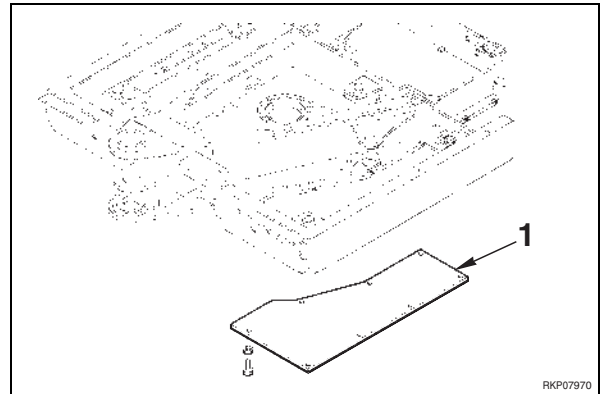

2 - Disconnect the tubes (3) from the steering unit (2).

★ Make some identifying marks on the tubes before disconnecting them, to avoid mixing up the positions when reconnecting.

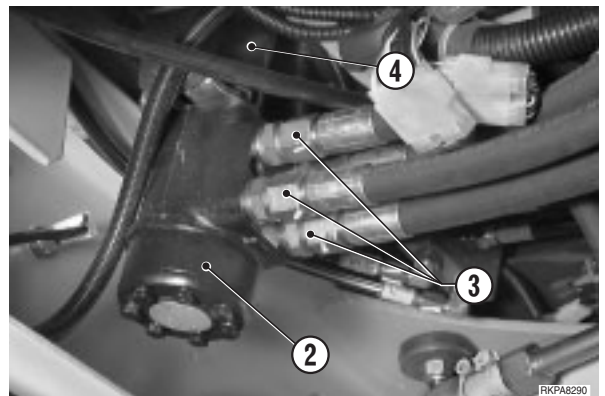

3 - Using the special wrench **Q1**, remove the screws that fasten the steering unit group (2) to the steering column (4).

★ In order to remove the front screws, attach the special wrench **Q1** to the steering unit (2) and move it with a normal wrench inserted in the lower provided between the cabin (5) and the revolving frame (6).

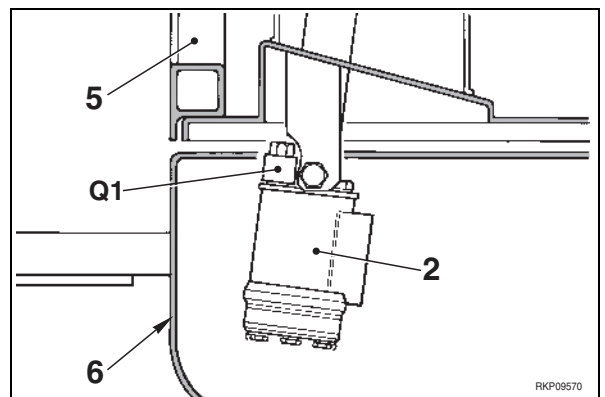

INSTALLATION OF THE STEERING UNIT

• To install, reverse the removal procedure.

1 - Start the engine and bleed air from the Load Sensing circuit (See «20. TESTING AND ADJUSTMENTS»).



13 - Mount the tool **Q2** and insert it in the guide already inserted in the hole of the steering unit.

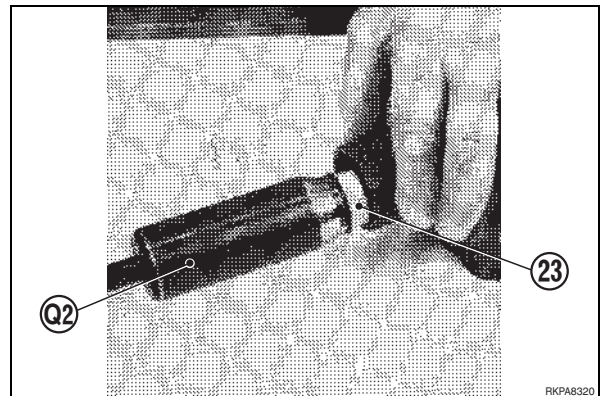

14 - Push the gasket (23) into the seating of the body of the steering unit (14), assisting the movement with slight rotatory movements.

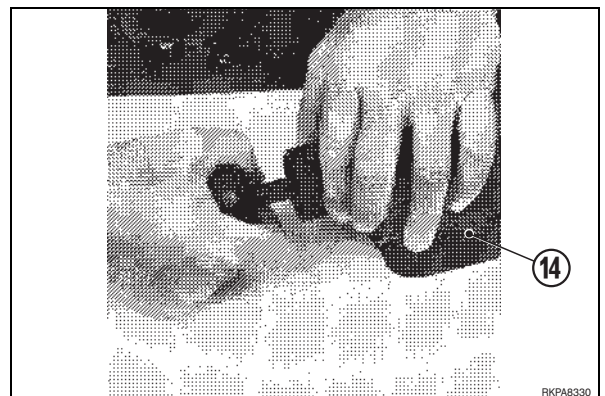

15 - Extract the guide from the body of the steering unit (14) using the tool **Q2**, and leaving in position the push-rod carrying the gaskets.

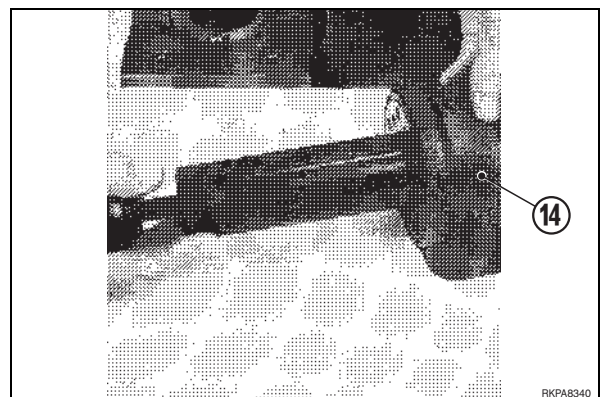

16 - Insert the bushing/spool group (13) into the hole of the steering unit (14).

Assist the insertion with slight rotatory movements.

★ Insert the group while keeping the cross pin horizontal.

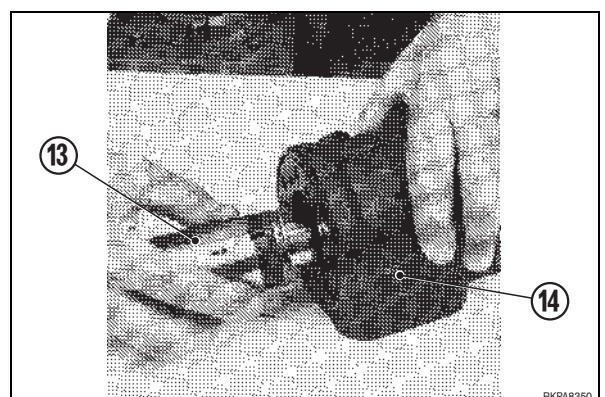

INSTALLATION OF THE TRAVEL MOTOR

- To install, reverse the removal procedure.

※ 1

 Screws: 34÷41 Nm

※ 2

- ★ Before connecting the drainage tube (5), fill the motor casing with hydraulic oil.

※ 3

- ★ Carefully check the O-ring seal between motor and transmission. If there are any doubts as to its condition, change it.

 Sealant: ASL800050

1 - Start the motor and travel both forwards and backwards at low speed to bleed the system and to check the leak-tightness of the tubing.

2 - Stop the motor and check the level of oil in the tank.

 If the travel motor is to be dismantled for any form of inspection or overhaul, before using the machine again check:

1 - The setting of the automatic displacement control system.

2 - The speed of the travel propeller shaft.

- ★ For test and adjustment procedures, see «20. TESTING AND ADJUSTMENTS».

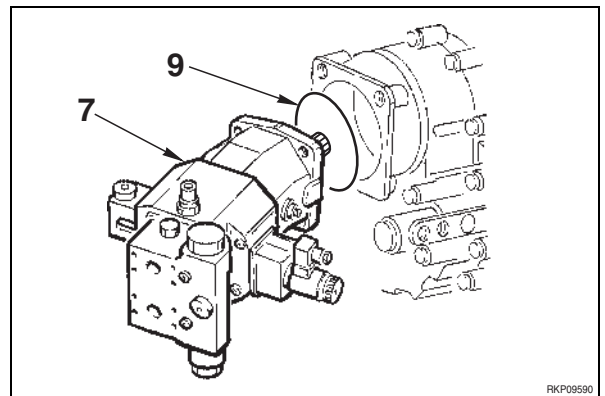

DISASSEMBLY OF THE TRANSMISSION

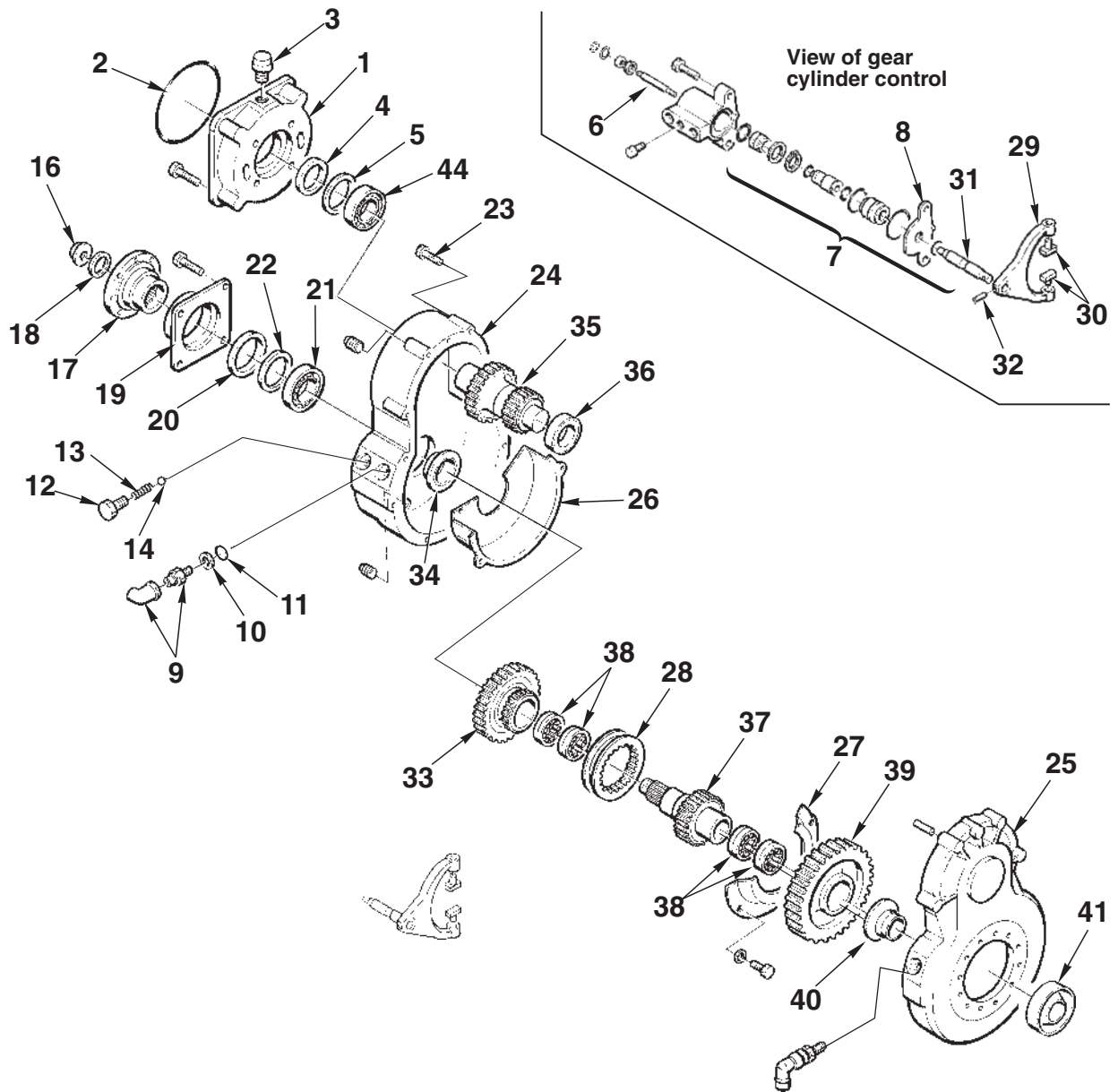

1 - Unscrew and take out the gear control shaft (6).

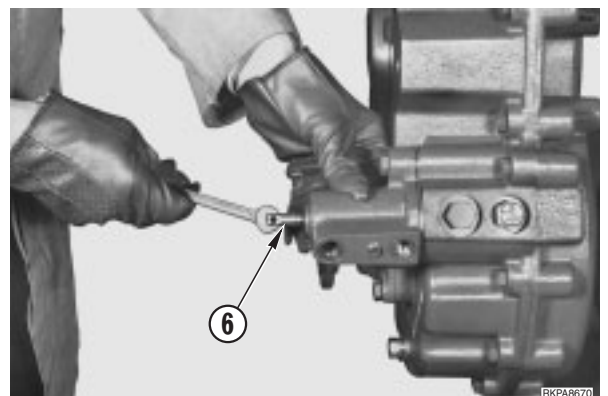

12 - Fit the housing (25) onto the casing (24) making sure to centre the pins.

- ★ Apply sealant to the surface of cover.
- ★ Use a plastic hammer to mate.

 Cover: Loctite 510

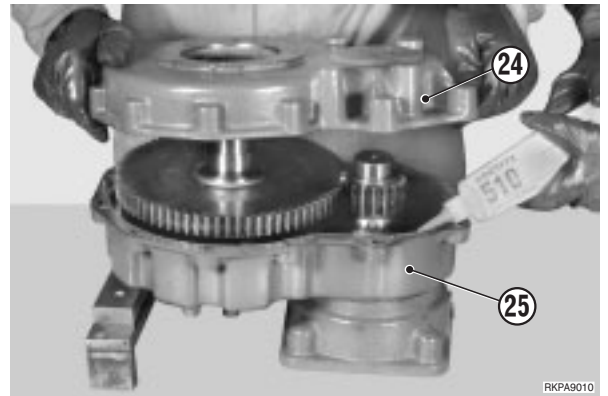

13 - Bolt casing (24) and housing (25) with screws (23).

 Screws: 48–62 Nm

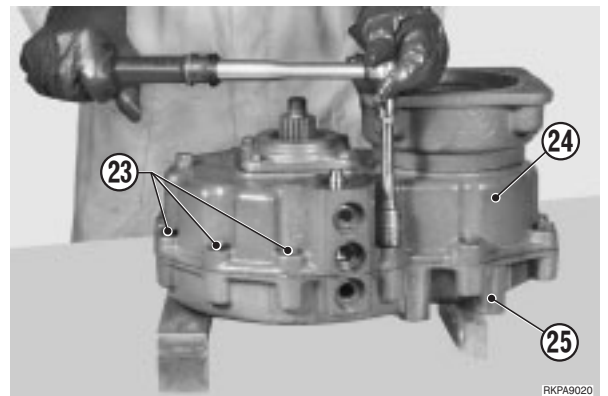

14 - Lubricate the ball (14), spring (13) and the screw (12) and install the neutral position assembly.

 Ball and spring: ASL800050

 Screw: 80–100 Nm

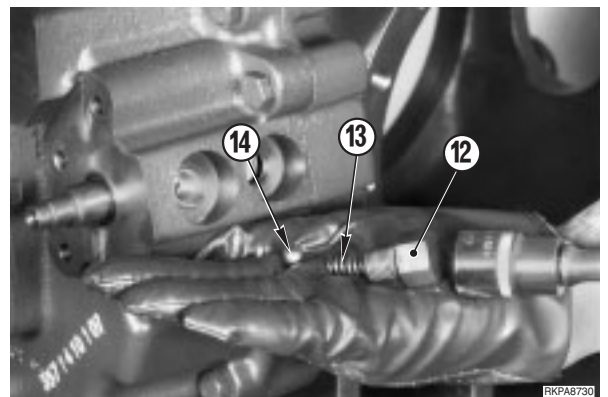

15 - Fit the in-gear-position microswitch (9), the O-ring (11) and washer (10).

 Microswitch: Max. 54.2 Nm

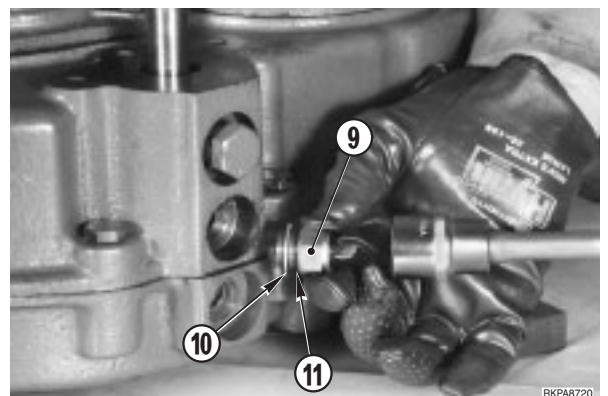

INSTALLATION OF REAR AXLE

- To install, reverse the removal procedure.
 - 1 - Refill the axle with lubricating oil and check tightness.
 - 2 - Start the engine to circulate the oil, recharge the accumulators of the brake line, and check the leaktightness.
 - 3 - Execute a few full steering manoeuvres.
 - 4 - Bleed air from the rear brake line.
(See «20. TESTING AND ADJUSTMENTS»).
 - 5 - Stop the engine and check the level of the oil in the tank.

4. Brakes

1 - Remove the swinging support (1) on the side opposite the drive.

- ★ If the bushing (2) is worn and needs replacing, note down the assembly side of the connection notch "A".

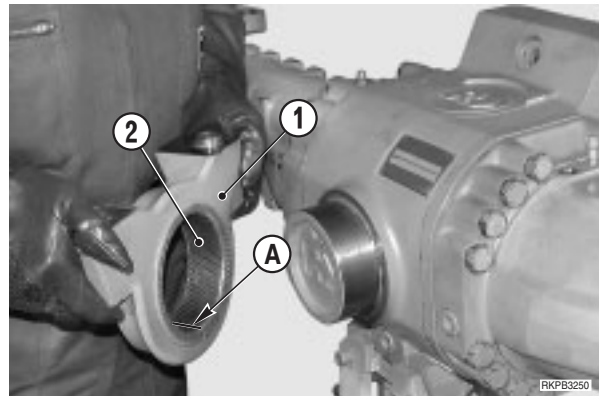

2 - Disconnect the pins of the steering bars from the steering case (See «5. STEERING CYLINDER»).

Only for rear axle

3 - Disconnect the negative brake cylinder.

4 - Sling the arm (3) to be removed and put the rod under slight tension.

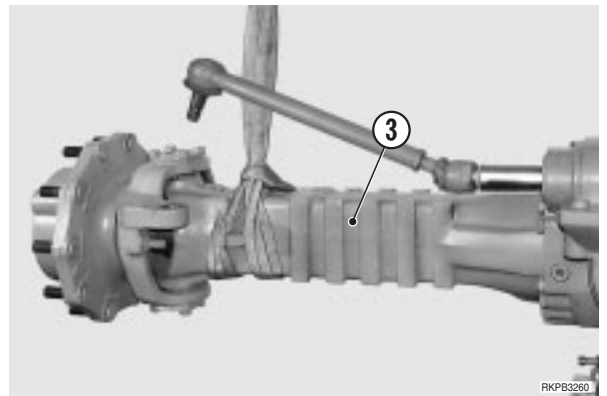

5 - Unloose and remove the screws (4) and the washers (5) that fix the arm (3) to the central body (6).

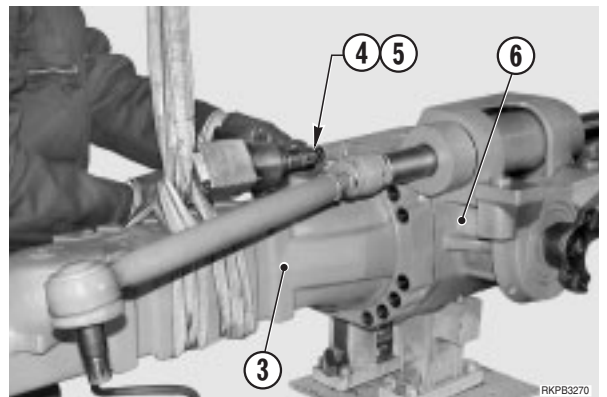

6 - Remove the arm (3) together with the pack of the braking disks (7). Place the arm on a bench.

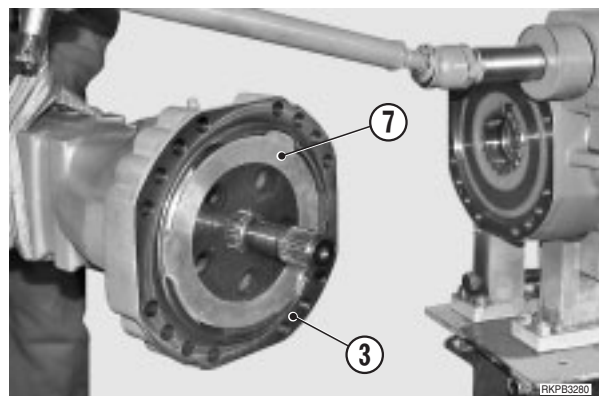

10 - If the bearing need replacing, extract the bearing (7) and remove the crown (12).

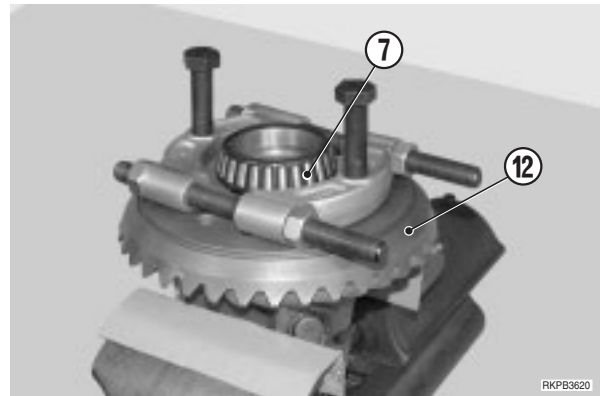

11 - Remove the shim washer (13) and the planetary gear (14).

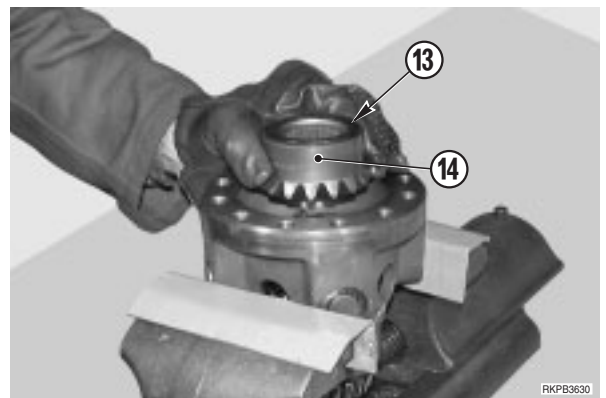

12 - If the bearing need replacing, extract the bearing (8) from the differential carrier (15).

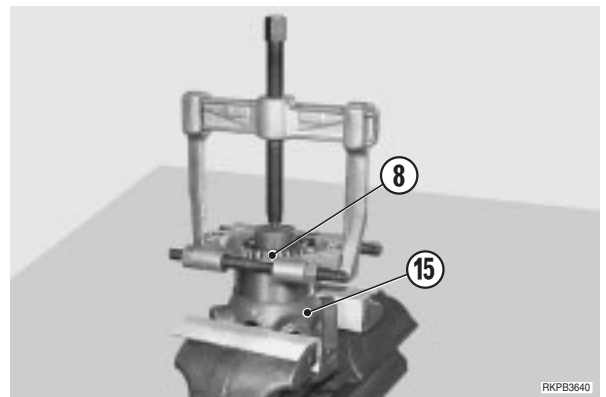

13 - Remove the snap rings (16) from the two pins (17) of the planet wheel gears (18).

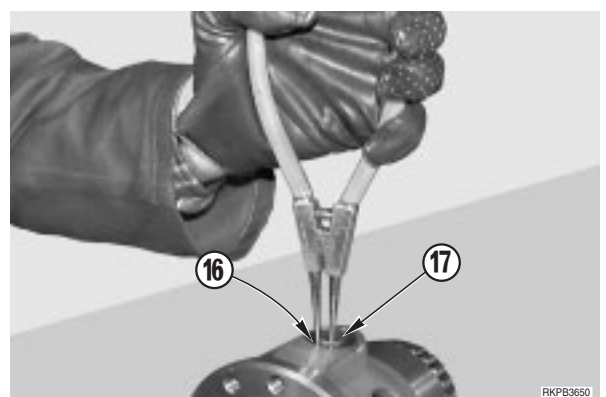

- 14 - Calculate the difference between sizes "B" and "C" so as to obtain the size "S" of the shim (16) that will go under the thrust block of the internal bearing (11).

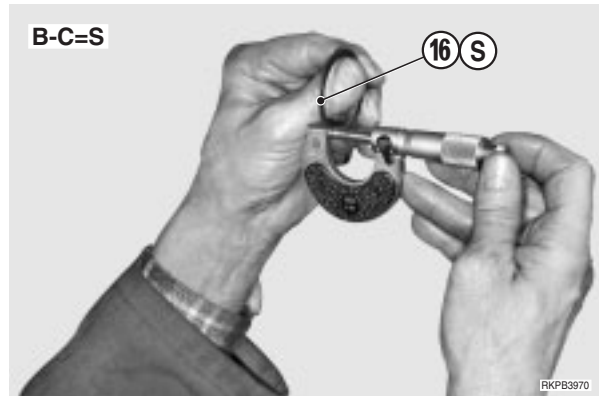

- 15 - Insert shim "S" (16) and the thrust block of the internal bearing (11) in the central body.
 ★ To hold shim "S" (16) in position, apply grease.

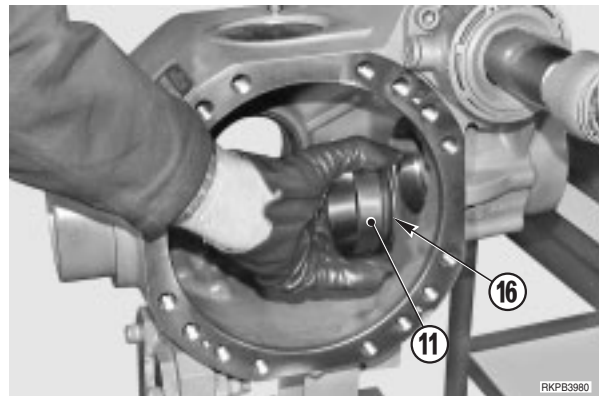

- 16 - Position tool **M10A** and tension rod **M10C**.
 Connect the tension rod to the press, fasten the thrust block and then remove the tools.
 ★ Before going on to the next stage, make sure that the thrust block has been completely inserted.

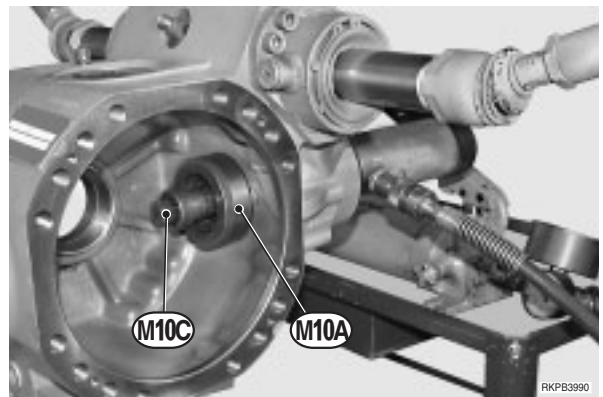

- 17 - Position tools **M11C** and **M11B** complete with tapered bearings (11) and (15); manually tighten until a rolling torque has been obtained.

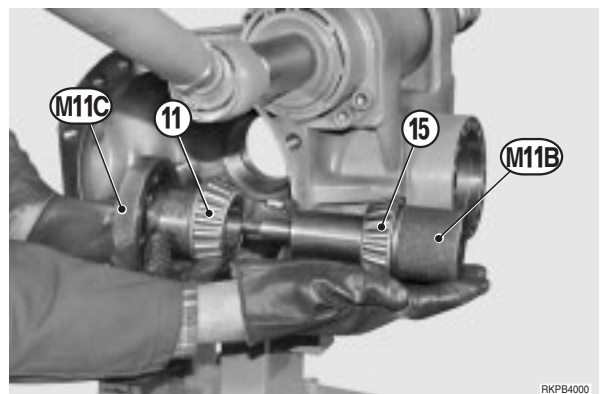

21 - Manually move the crown (12) in both directions in order to check the existing backlash between the pinion and the crown.

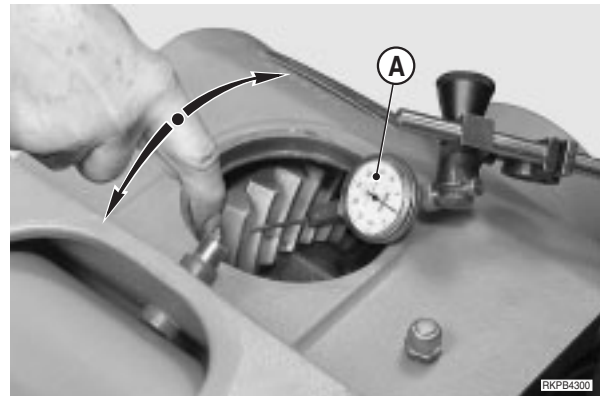

22 - Adjust the backlash between the pinion and the crown by unloosening one of the ring nuts (1) and tightening the opposite to compensate.

- ★ Normal backlash: 0.18–0.23
- ★ Difference between MIN. and Max. clearance for whole circumference should not exceed 0.09 mm.

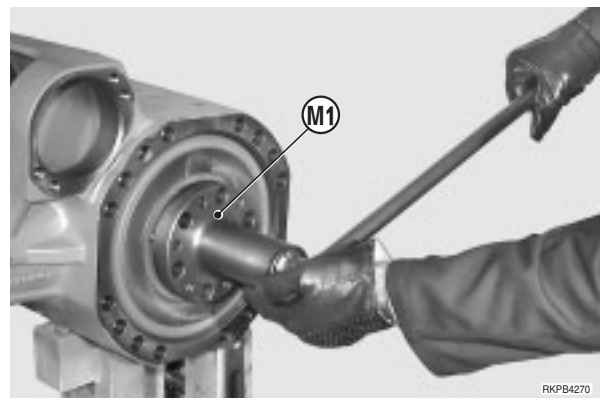

23 - Apply Loctite 242 to the screws (3), fit them into one of the two holes and tighten.

 Torque wrench setting: 23.8–26.2 Nm

24 - Fit the top plug (10) after applying repositionable jointing compound for seals to the rims.

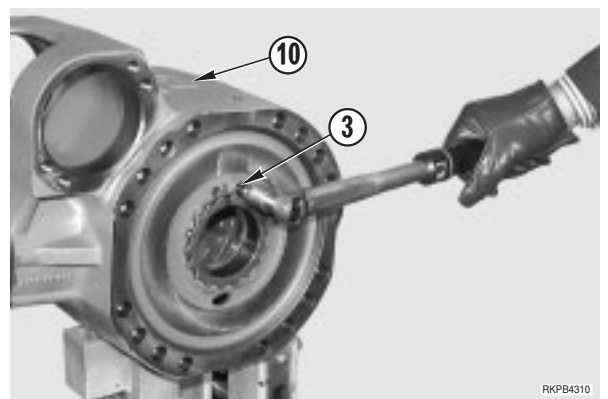

25 - Re-install the complete arms.
For details, see Assembly «3. BRAKE».

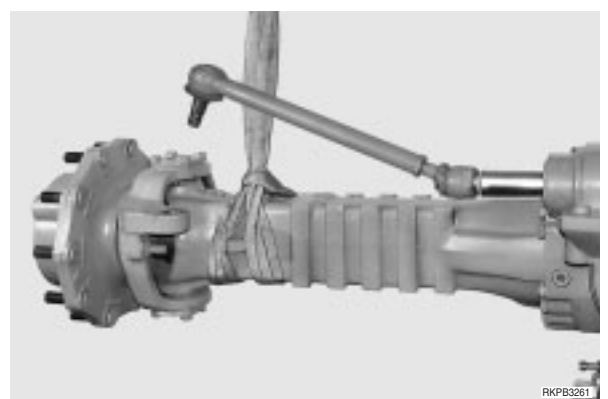

6. Install of steering cylinder

1 - Check that the O-rings (15) of the axle unit are in good condition; lubricate the seats of the seals (15) and fit the steering cylinder (9) into its seat.

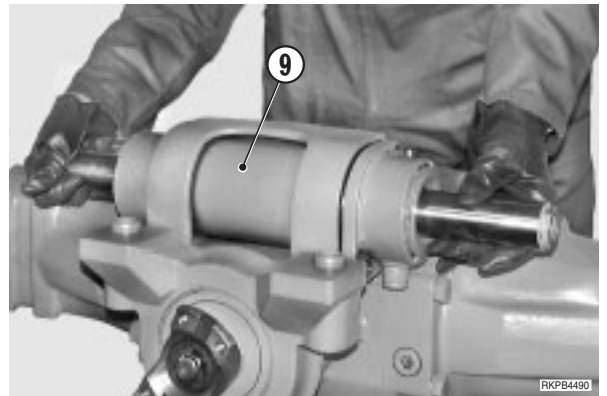

2 - Lock the cylinder by cross-tightening the screws (8).

 Torque wrench setting: 116–128 Nm

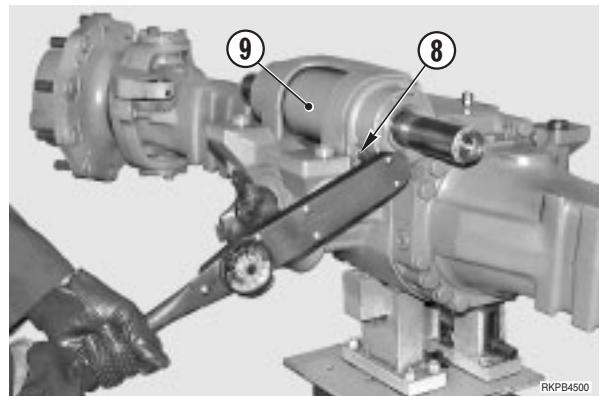

3 - Apply Loctite 242 to the thread and connect the steering bars by screwing the terminals onto the piston stem.

 Torque wrench setting: 240–270 Nm

★ Versions with coupling require that the rim of the articulation (13) is riveted onto the surfaces of the piston stem.

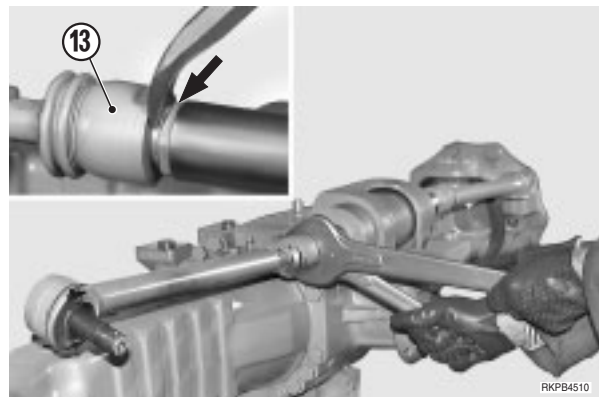

4 - Insert the pins (4) in the steering case (7) and lock into position using a torque wrench setting of 260–290 Nm. Find the position of the notching in relation to the hole of the cotter pins and tighten the nut (6) further.

 Check that rubber guards (A) are intact.

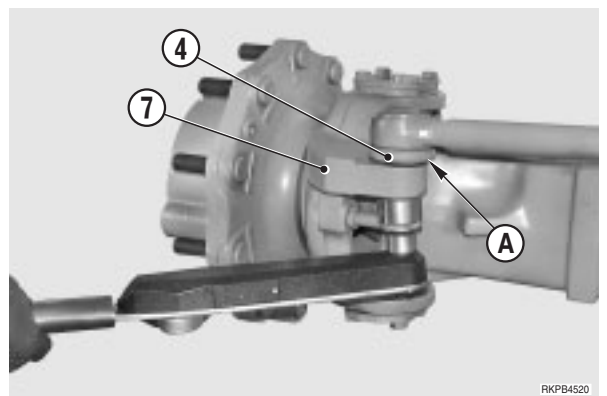

14 - Lock the gears (10) into position by fitting the snap rings (9).



15 - Fit the steering case (3) onto the U-joint (19) and install the articulation pins.
For pin assembly details, see Assembly «9. STEERING CASE».

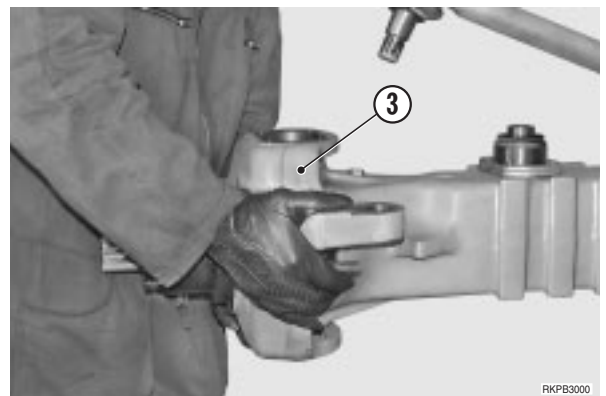

16 - Connect the steering bars. (For details, see «6. ASSEMBLY OF STEERING CYLINDER»).

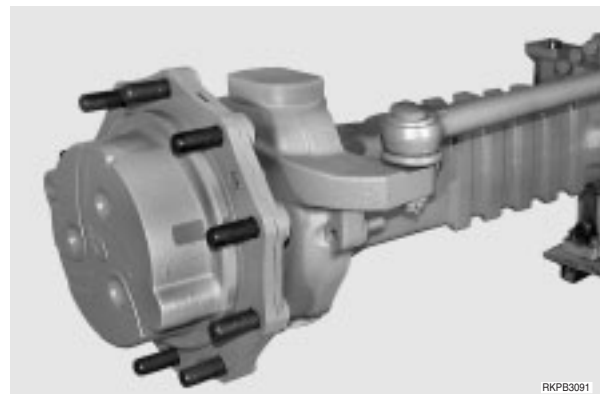

17 - Install the hub (7).

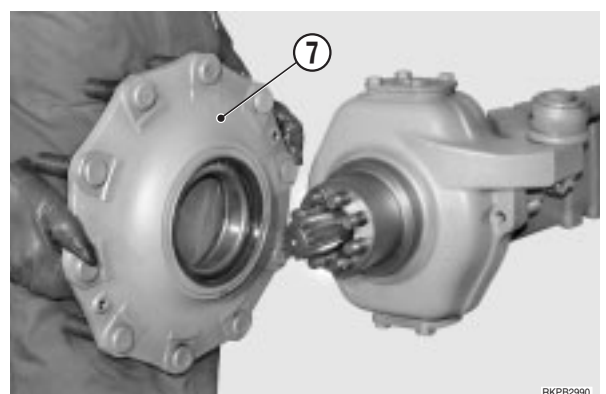

REMOVAL OF BOOM SWING CYLINDER

- 1 - Swing the boom to the right to extend the cylinder fully.
- 2 - Swing the revolving frame 45° and rest the work equipment on the ground.
- 3 - Switch off the engine and move the PPC valve several times to release all residual pressures.
- 4 - Remove the RH front guard (1) from the revolving frame (2).
- 5 - Disconnect the tubes (3) from the cylinder and plug them. Also plug the flanges (4) of the cylinder (5).
- 6 - Disconnect the lubricator tube (6).
- 7 - Place a block beneath the cylinder head to prevent the edge of the frame making dents in the piston rod. Also place a support beneath the cylinder.
- 8 - Remove the screw (7), draw out the pin (8) and detach the piston rod from its support (9). ※ 1 ※ 2
- 9 - Remove the screws (10) and draw out the stop (11) and the pin (12). ※ 2 ※ 3 ※ 4
- 10 - Slide the cylinder out partially from the front and, as soon as possible, put it in a sling and lift it off.

- ★ During this operation take great care not to dent the piston rod.

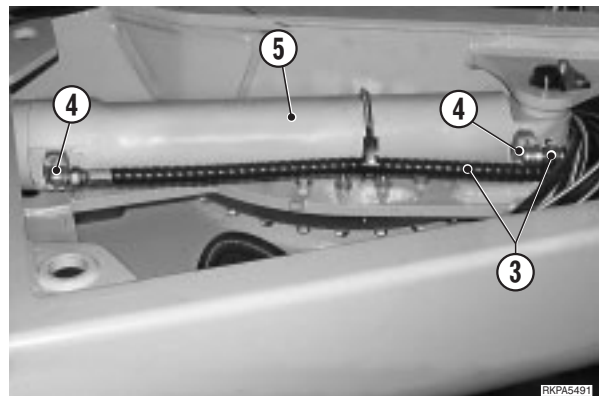
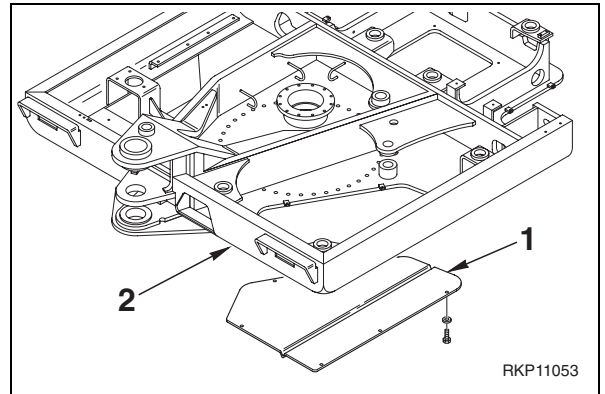

INSTALLATION OF BOOM SWING CYLINDER

- To install, reverse the removal procedure.

- ※ 1
- ★ Insert the spacers to a given clearance (distributed on both sides of the piston) until a clearance of 1–2 mm is obtained.

- ※ 2
- ⚠ When aligning the positions between hole and pin, let the engine run at minimum idling. Do not insert fingers into the hole to check the alignment.

- ※ 3
- 🔧 Inside bushings: ASL800050

- ※ 4
- ★ Insert the spacers to a given clearance (distributed on both sides of the cylinder) until a clearance of 0.5–1 mm is obtained.

- Start the engine and bleed air from the cylinder. (For details, see «20. TESTING AND ADJUSTMENTS»).
- ★ After bleeding the air, check the oil level in the tank.

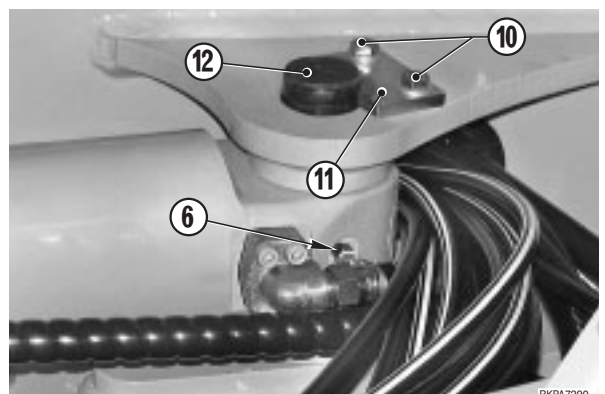
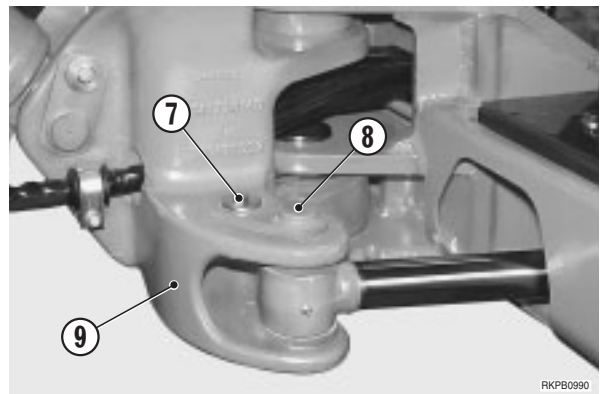

REMOVAL OF BUCKET

! Lower the bucket to the ground, resting with its back on a flat surface.

1 - Take out the safety pin (1) and the connecting pin (2) between bucket (3) and tie-rod (4).

※ 1 ※ 2 ※ 3

2 - Take out the safety pin (5) and the pin (6) that connects the bucket to the arm (7).

※ 2 ※ 3 ※ 4

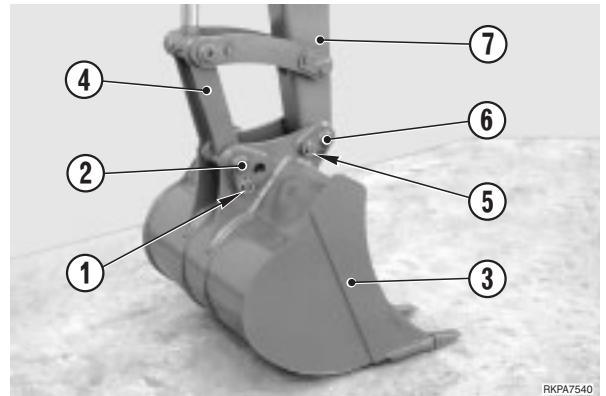

INSTALLATION OF BUCKET

• To install, reverse the removal procedure.

※ 1

★ Insert the spacers to a given clearance between bucket (3) and tie-rod (4).

※ 2

! When lining up the hole and the pin, let the engine turn at low idling speed. Do not insert fingers into the holes to check alignment.

※ 3

 Inside bushings: ASL800050

※ 4

★ Insert the spacers to a given clearance (on both sides) between the bucket (3) and the arm (7), until a play of 0.5–1 mm is obtained.

REMOVAL OF BLADE AND OUTRIGGERS

- 1 - Raise the blade (1) or the outriggers (2) and place blocks (A) under the arms (3); Lower the equipment until the arms rest lightly on the blocks.

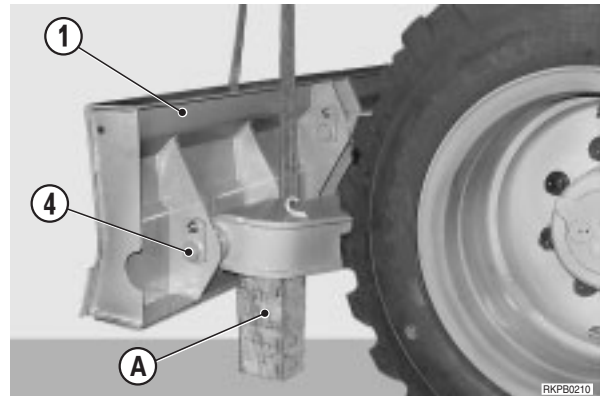

- 2 - Attach the blade (1) or the outriggers (2) to the lifting equipment and apply slight tension to the cables.

- 3 - Take out the screws and remove the pins (4).

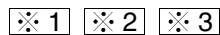

- 4 - Remove the blade (1) or the outriggers (2).

kg Blade: 210 kg
Outrigger: 29 kg

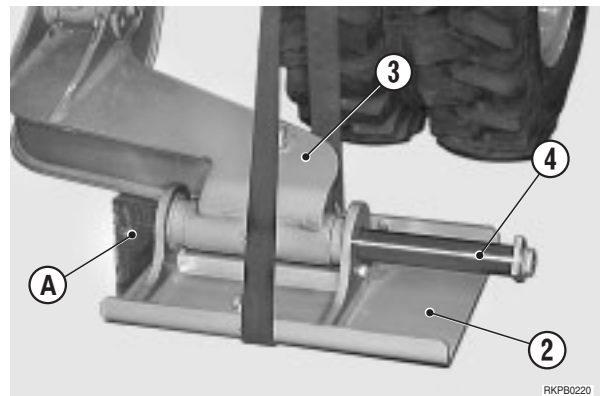

INSTALLATION OF BLADE AND OUTRIGGERS

- To install, reverse the removal procedure.



Internal bushings: ASL800050



⚠ Do not insert fingers into the holes to check on alignment.



- ★ Insert the shims on both sides of the arm, in order to obtain a clearance of 0.5–1 mm

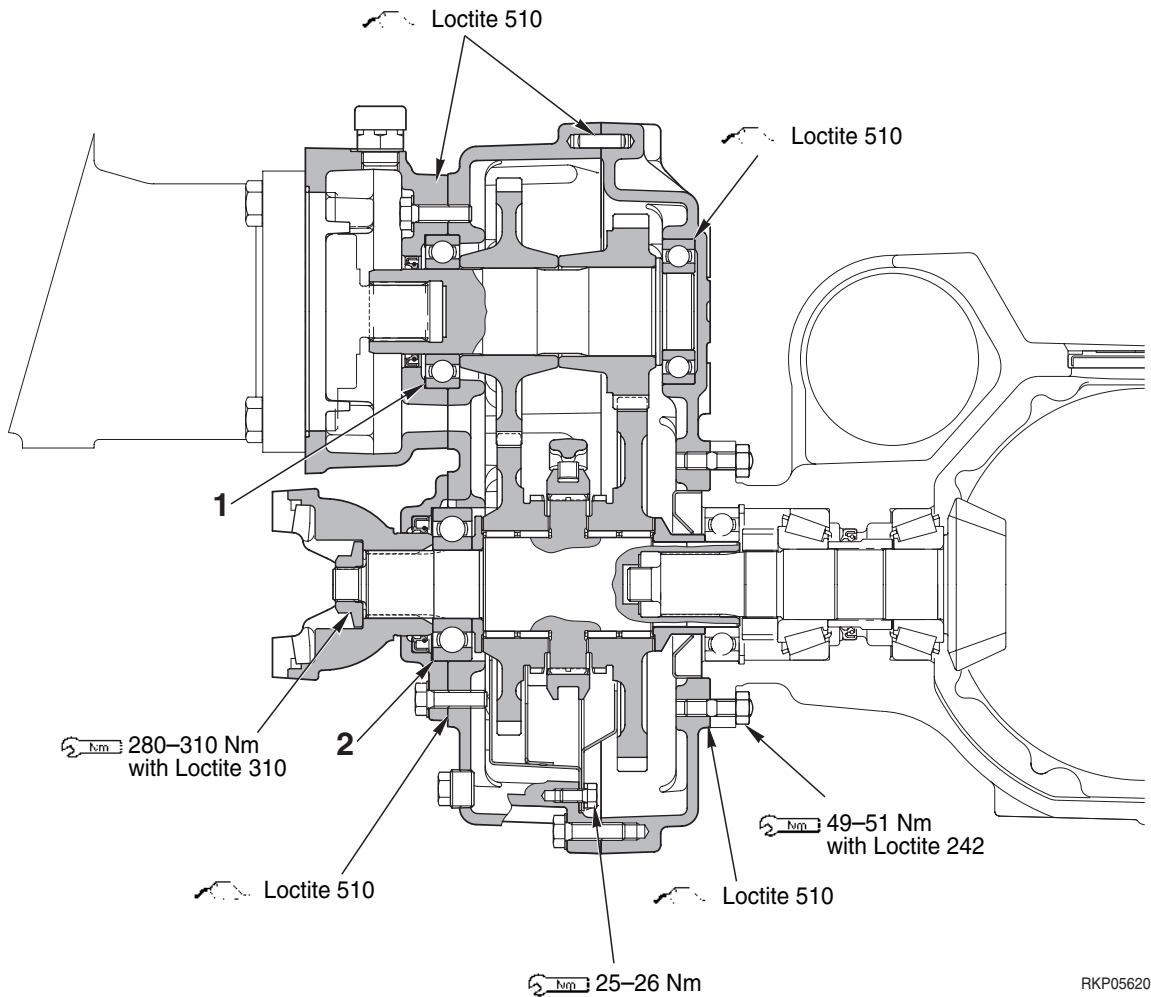

RKP05620

Unit: mm

| No. | Check item | Criteria | | Remedy |
|-----|-------------------|--------------------|-----------------|--------|
| | | Standard clearance | Clearance limit | |
| 1 | Bearing clearance | 0.25-0.35 | - | Adjust |
| | | 0.20-0.30 | - | |

Unit: mm

| No. | Check item | Criteria | | Remedy |
|-----|---|--------------------|-----------------|---------|
| 1 | Backlash between No. 2 planetary gear and housing | Standard clearance | Clearance limit | Replace |
| | | | | |
| 2 | Backlash between No. 1 planetary gear and housing | | | |
| 3 | Backlash between No. 1 sun gear and No. 1 planetary gear | | | |
| 4 | Backlash between No. 2 sun gear and No. 2 planetary gear | | | |
| 5 | Backlash between swing pinion and swing circle gear | | | |
| 6 | Wear of swing pinion shaft surface contacting with oil seal | Standard size | Size limit | |
| | | | | |

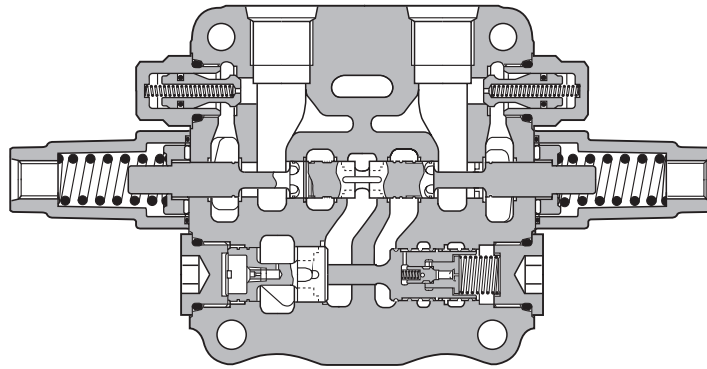

RKP02853

Section G - G

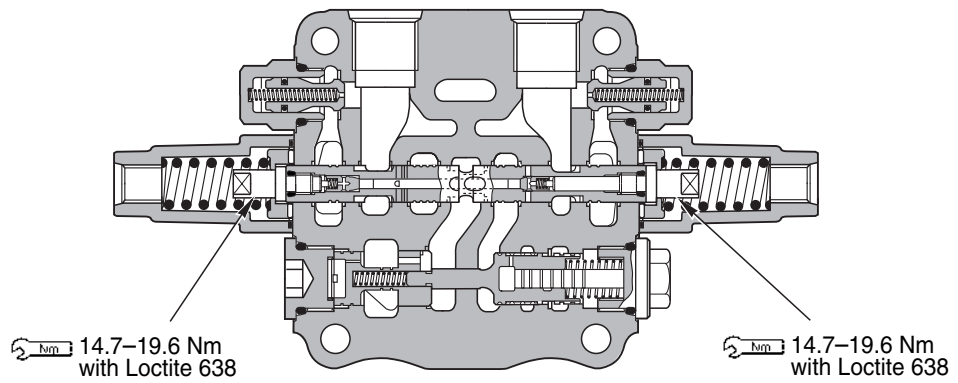

Section H - H

RKP02863

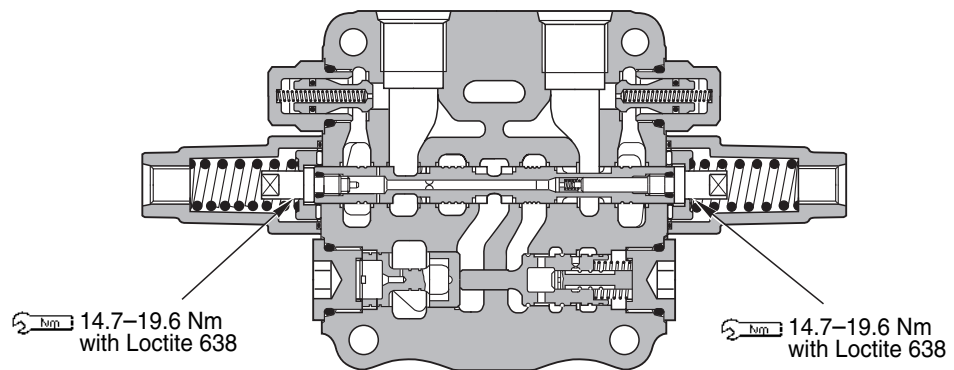

Section J - J

RKP02873

BLADE SAFETY VALVE

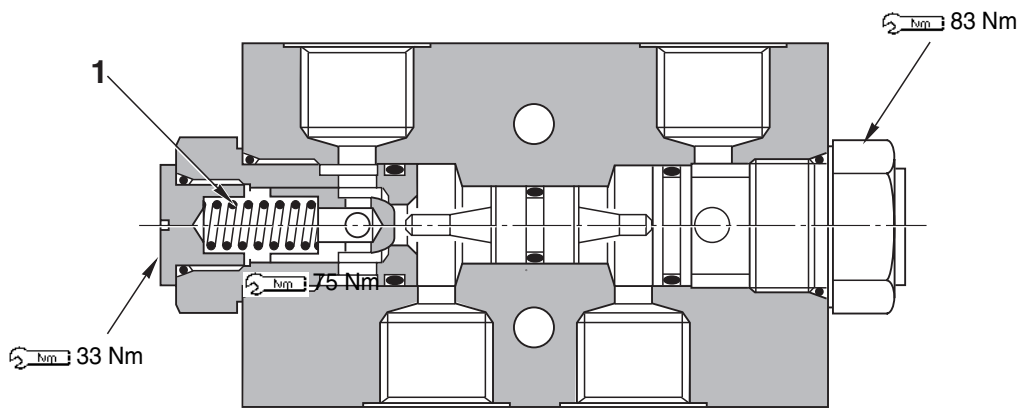

RKP04580

Unit: mm

| No. | Check item | Criteria | | | | | Remedy |
|-----|--------------------|--------------------|------------------|----------------|--------------------|----------------|---------|
| | | Standard size | | | Repair limit | | |
| 1 | Check valve spring | Free length xØe | Installed length | Installed load | Free length xØe | Installed load | Replace |
| | | 16.5 | 11.12 | 2.465 kg | 13.5 | 1.1 kg | |

CLICK HERE TO **DOWNLOAD** THE COMPLETE MANUAL

- Thank you very much for reading the preview of the manual.
- You can download the complete manual from: www.heydownloads.com by clicking the link below



- Please note: If there is no response to CLICKING the link, please download this PDF first and then click on it.

CLICK HERE TO **DOWNLOAD** THE COMPLETE MANUAL