

SHOP MANUAL

WEBM000600



PW75-1

HYDRAULIC EXCAVATOR

SERIAL NUMBER

000001 and up

- This shop manual may contain attachments and optional equipment that are not available in your area.
Please consult your local FKI distributor for those items you may require.
Materials and specifications are subject to change without notice.
- PW75-1 mount the KOMATSU 4D98E-1FB engine.
For detail of the engine, see the KOMATSU series 98 Engine Shop Manual.



FKI FAI KOMATSU INDUSTRIES S.p.A.

HEAD OFFICE: VIA ATHESTE 4 35042 ESTE (PADOVA) ITALY

Tel. +39 0429 616111 • Fax +39 0429 601000

CLICK HERE TO **DOWNLOAD** THE COMPLETE MANUAL

- Thank you very much for reading the preview of the manual.
- You can download the complete manual from: www.heydownloads.com by clicking the link below



- Please note: If there is no response to CLICKING the link, please download this PDF first and then click on it.

CLICK HERE TO **DOWNLOAD** THE COMPLETE MANUAL

STANDARD TIGHTENING TORQUE

2. TIGHTENING TORQUE FOR NUTS OF FLARED

Use these torques for nut part of flared.

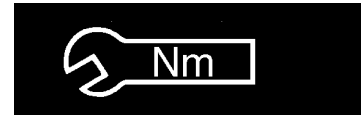
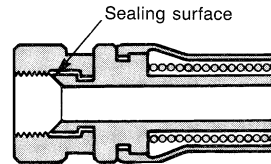

Thread diameter of nut part (mm)	Width across flats of nut part (mm)	TIGHTENING TORQUE	
		kgm	Nm
1/2" - 20	17	2.6±0.5	25.5±4.9
9/16" - 18	17	4±0.5	39.2±4.9
3/4" - 16	22	6.7±2	65.7±19.6
7/8" - 14	27	8±2	78.5±19.6
1.1/16" - 12	32	9.7±3	95.15±29.4
1.5/16" - 12	38	17±3	166.7±29.4
1.5/8" - 12	50	20±5	196.2±49
22	27	8±2	78.5±19.6
33	41	20±5	196.2±49

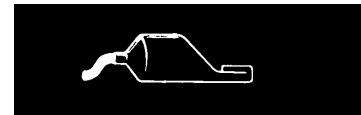

COATING MATERIALS

The recommended coating materials prescribed in FKI Shop Manuals are listed below:

Nomenclature	Code	Applications
Adhesives	ASL800010	Used to apply rubber pads, rubber gaskets and cork plugs.
	ASL800020	Used to apply resin, rubber, metallic and non-metallic parts when a fast, strong seal is needed.
	Loctite 222	Used for low resistance locking of screws, check nuts and adjustment nuts.
	Loctite 242	To prevent the loosening of bolts, nuts and plugs and the leakage of oil. Used for medium resistance locking of screws and nuts of every type, and for locking keys and bearings.
	Loctite 262	Used for high resistant of threaded parts that can be removed with normal tools.
	Loctite 270	Used for high resistant locking and for sealing threaded parts, bolts and stud bolts.
	Loctite 542	Used for sealing the union threads for hydraulic tubes.
	Loctite 573	Used for sealing rather exact plane surfaces when the option of possible future dismantling is required.
	Loctite 601	Used for high resistant locking of mechanical components that can be removed only after heating
Gasket sealant	ASL800060	Used by itself to seal grease fittings, tapered screw fittings and tapered screw fittings in hydraulic circuits of less than 50 mm in diameter.
	ASL800070	Used by itself on mounting surface on the final drive and transmission cases. (Thickness after tightening :0.07-0.08 mm).
Antifriction compound (Lubricant including Molybdenum disulfide)	ASL800040	Applied to bearings and taper shaft to facilitate press-fitting and to prevent sticking, burning or rusting.
Grease (Lithium grease)	ASL800050	Applied to bearings, sliding parts and oil seals for lubrication, rust prevention and facilitation of assembling work.
Vaseline	-	Used for protecting battery electrode terminals from corrosion.

Final reduction

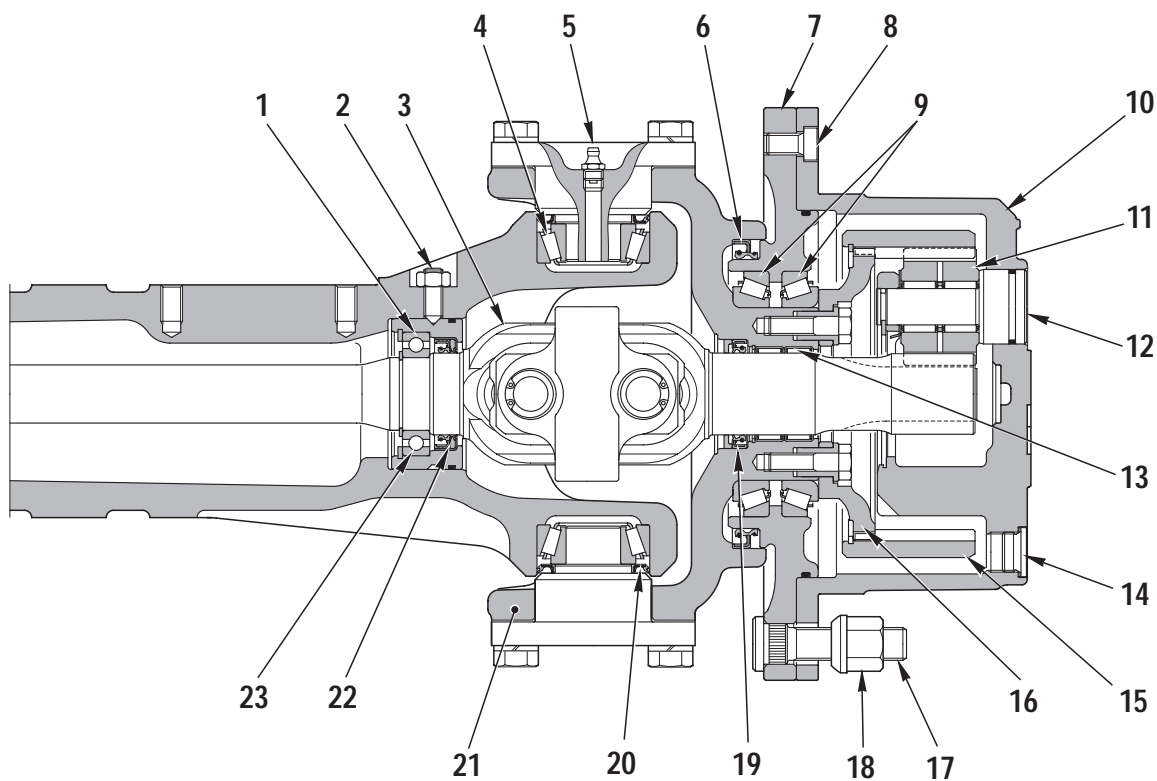

D0401148

- | | |
|--------------------------|------------------------|
| 1. Bearing | 13. Bearing |
| 2. Dowel | 14. Plug |
| 3. Cardan shaft (Z = 12) | 15. Ring gear (Z = 51) |
| 4. Bearing | 16. Ring gear carrier |
| 5. Pin | 17. Stud bolt |
| 6. Seal | 18. Nut |
| 7. Wheel hub | 19. Seal |
| 8. Screw | 20. Seal |
| 9. Bearing | 21. Housing |
| 10. Support | 22. Seal |
| 11. Bevel gear (Z = 19) | 23. Bearing |
| 12. Pin | |

SPECIFICATIONS

Amount of oil: 0.7 ℓ
 Reduction ratio: 1:5.25

TRANSMISSION (4WS)

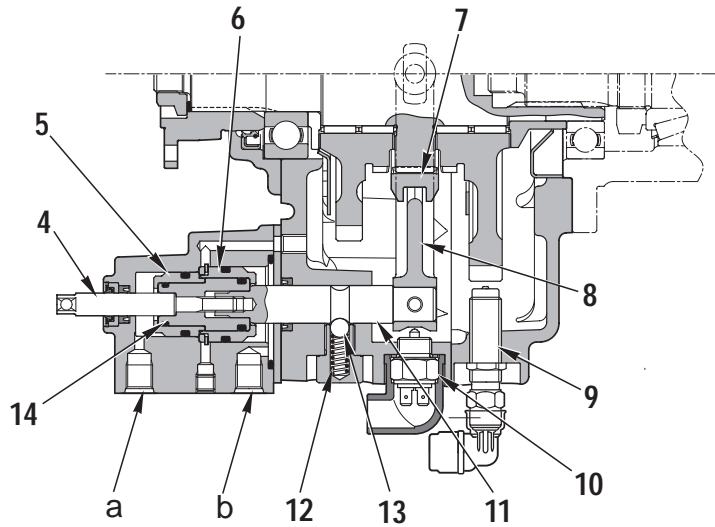
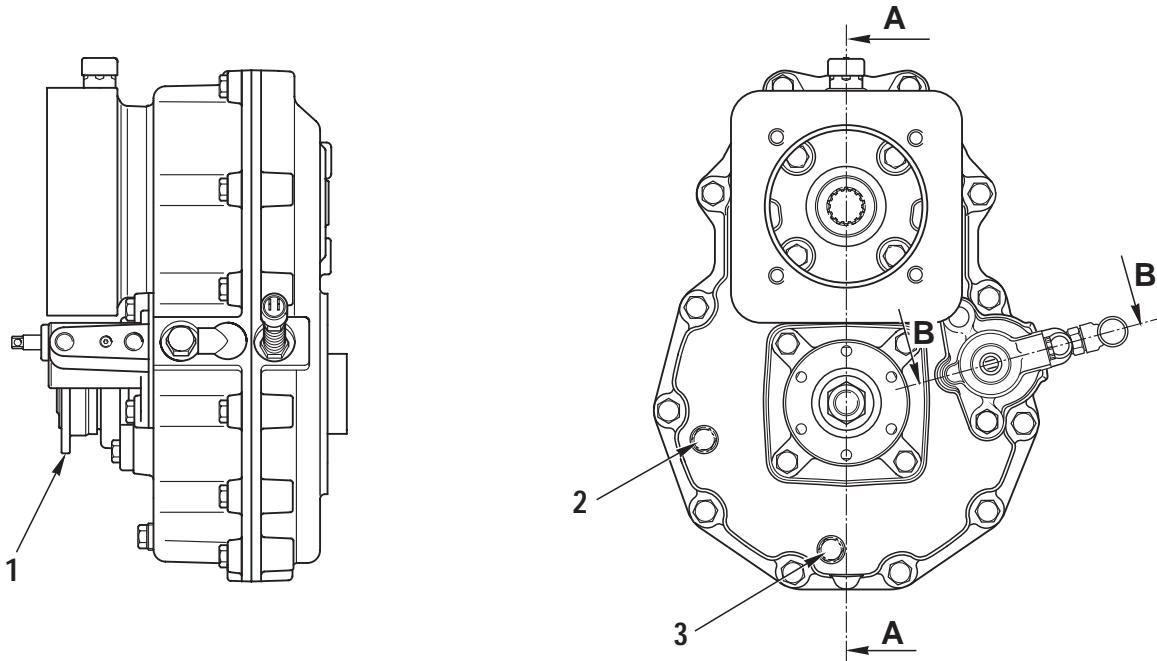

Section B - B

D0401151

a. e Port - From swivel joint (14a Port)
 b. f Port - From swivel joint (5a Port)

- | | |
|-------------------------------|--------------------|
| 1. Flange | 8. Selecting fork |
| 2. Filler and level oil plug | 9. Speed sensor |
| 3. Oil drain plug | 10. Safety switch |
| 4. Neutral manual control | 11. Selector shaft |
| 5. Low speed selector piston | 12. Spring |
| 6. High speed selector piston | 13. Ball |
| 7. Selector gear | 14. Piston |

3 - Steering with 4 wheels steering in the same direction.

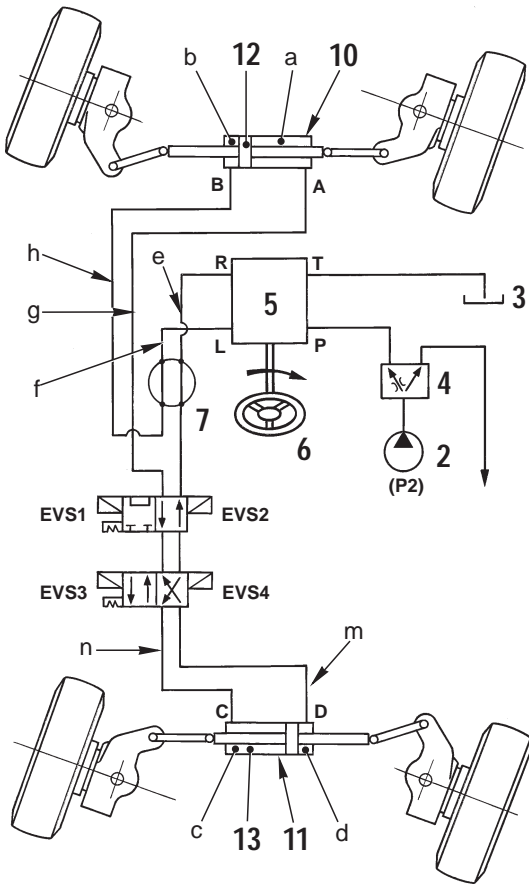

D0401164

STEERING TO THE RIGHT

Turning the steering wheel (6) clockwise causes rotation of the steering metering group (5) and prepares the control valve (port R) to send oil (through line e) to solenoid valve group and thence through line m into chamber c of cylinder (11).

The pressurized oil moves the piston (13) of the cylinder (11) that steers the wheels while simultaneously impelling the oil in chamber d (at the same pressure as chamber c) through lines m and g into chamber a of the cylinder (10).

The oil in chamber b of cylinder (10) is sent through lines h and f to the control valve of the steering group (5) (port L) from which the oil passes (port T) to drain into the tank (3).

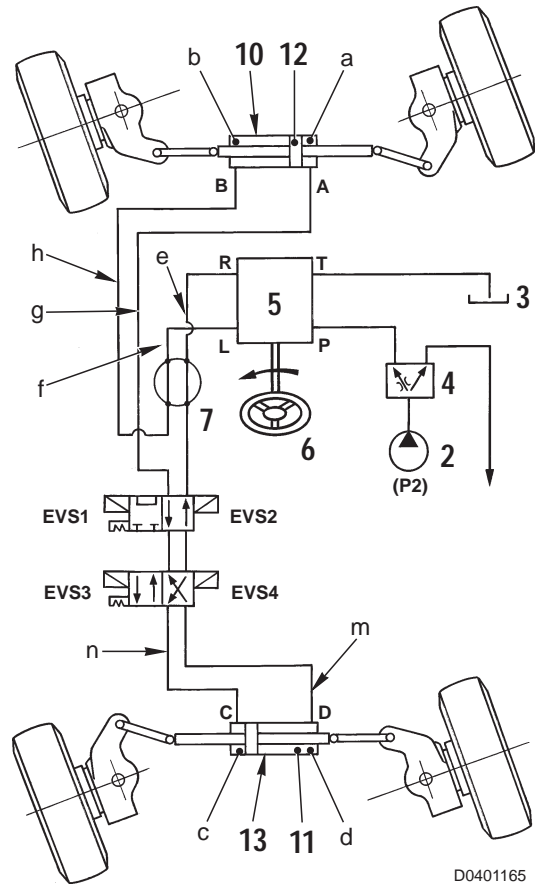

D0401165

STEERING TO THE LEFT

Turning the steering wheel (6) anti-clockwise causes rotation of the steering metering group (5) and prepares the control valve (port L) to send oil through lines f and h into chamber b of cylinder (10).

The pressurized oil moves the piston (12) of cylinder (10) which in turn steers the wheels while simultaneously impelling the oil in chamber a (at the same pressure as chamber b) through lines g and m into chamber d of cylinder (11).

The oil in chamber c of cylinder (11) is impelled through lines n and e to the control valve of the steering group (5) (port R) from which it passes (port T) to drain into the tank (3).

HYDRAULIC PUMP

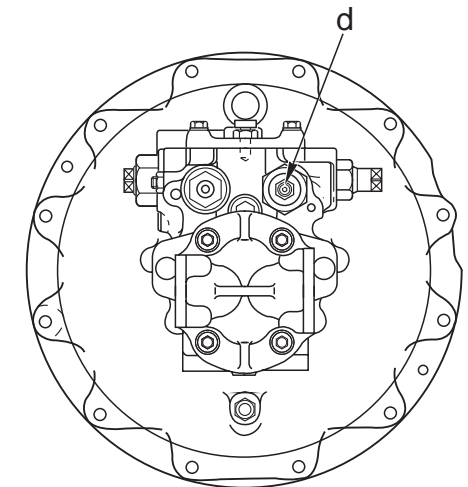
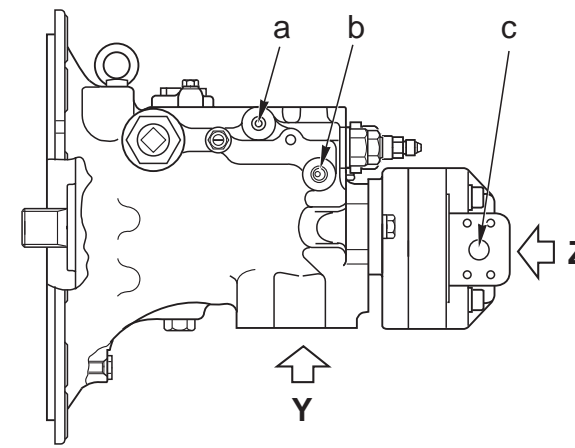

View Z

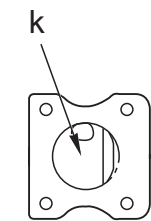
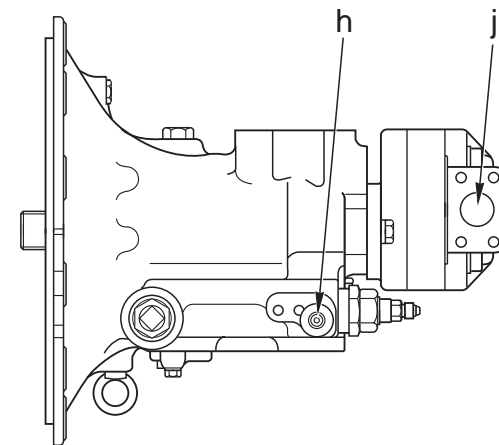
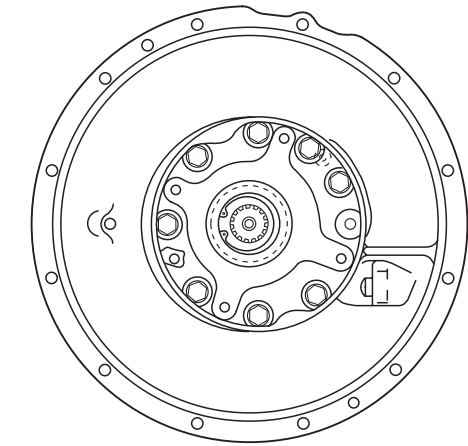
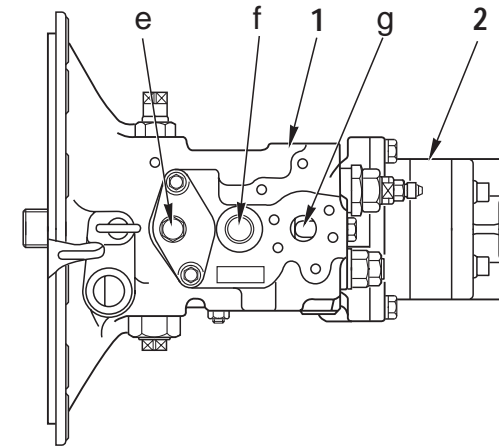

View Y

- a. PPLS Port - From control valve (PLS port)
- b. PLS Port - From control valve (P1 port) and from servocontrol feed unit (P2 port)
- c. PGA Port - From control valve (P2 port)
- d. PM Port - From ST1 solenoid valve group (A3 port)
- e. PDA Port - Air breeder port
- f. PD Port - Main pump drain

- g. PA Port - To servocontrol feed unit (P1 port)
- h. PA3 Port - From gear pump (PGA port)
- j. Pgs Port - From hydraulic tank
- k. Ps Port - From hydraulic tank

- 1. Hydraulic pump
- 2. Gear pump

D0400818

2. When the opening of the control valve is large (lever stroke large)

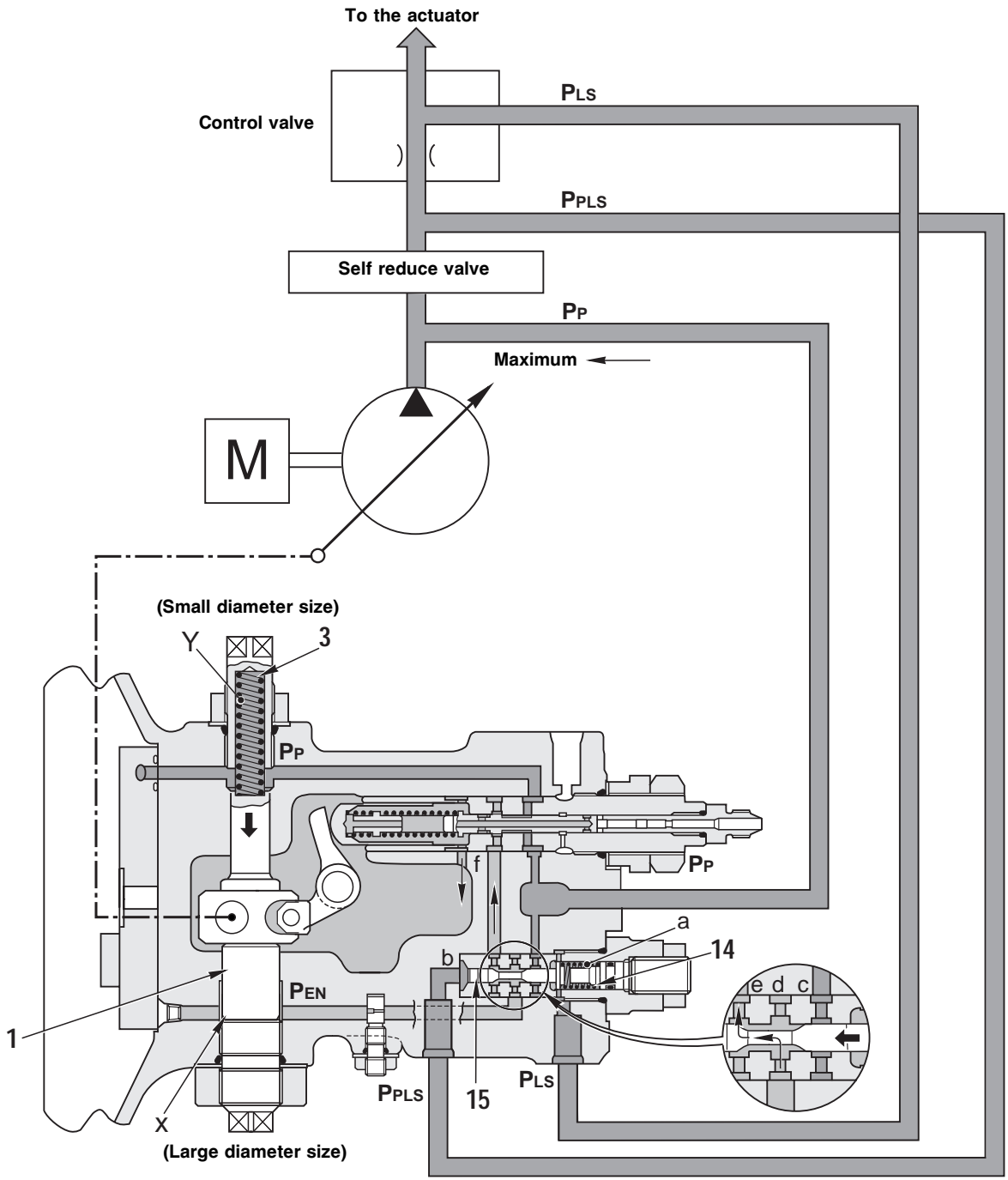

D0400814

2. When load on the actuator becomes small (pump discharge pressure lowers)

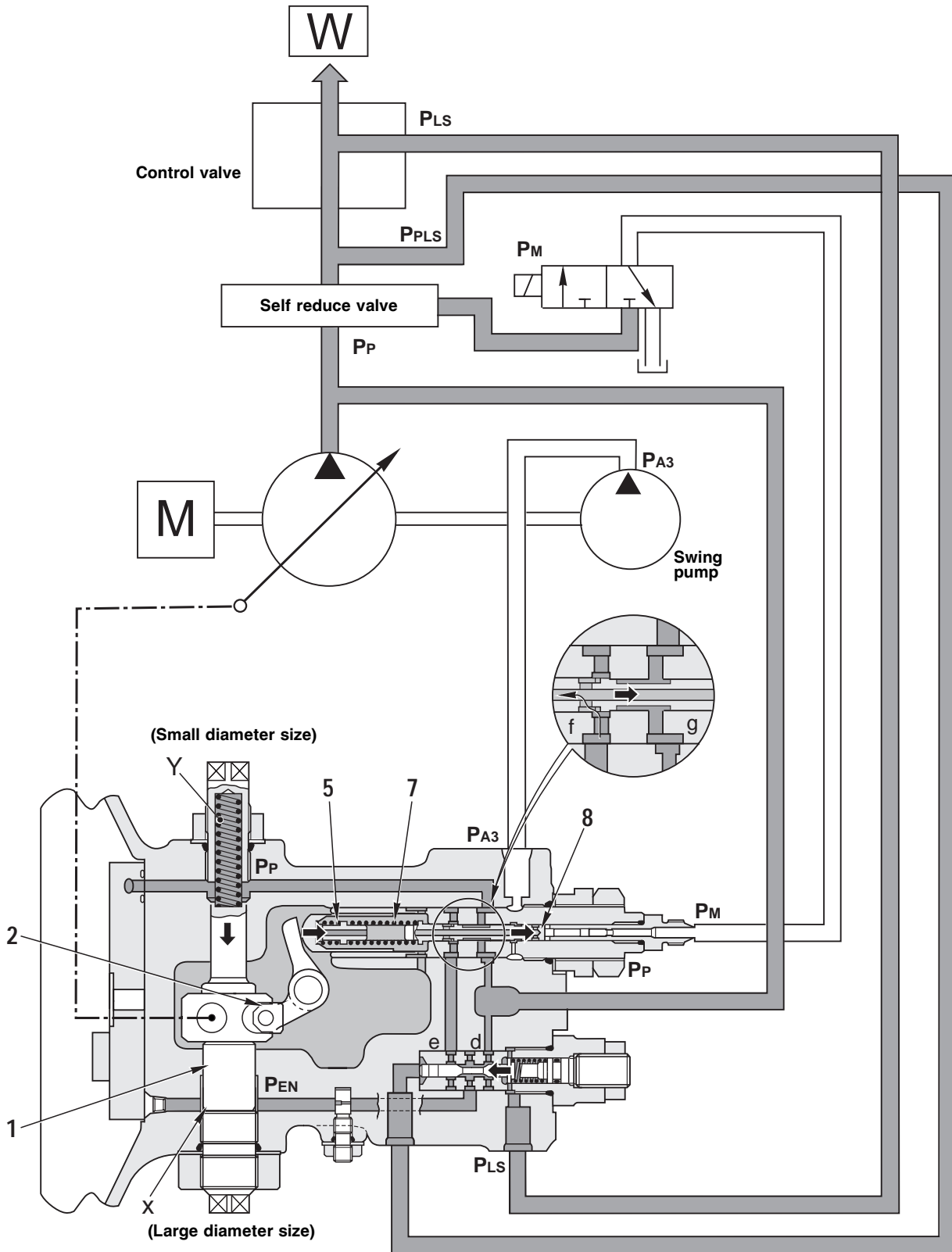

D0400820

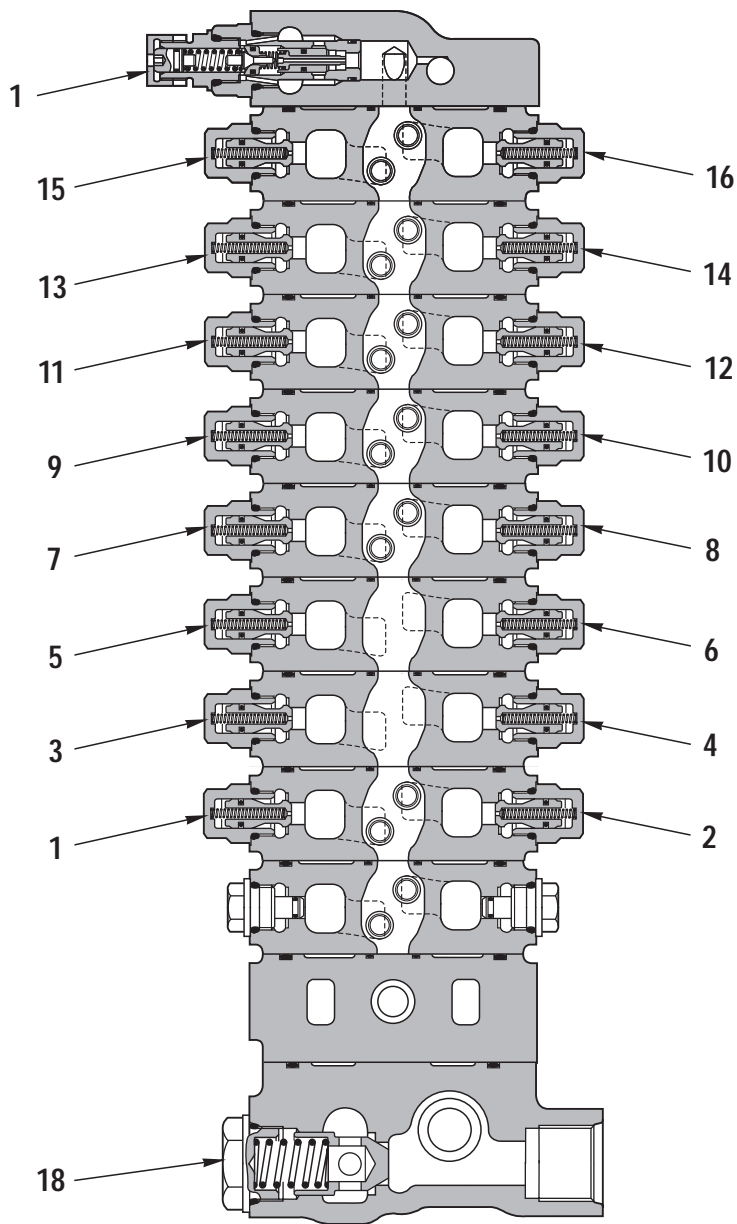

Section A - A

D0401179

- | | |
|---|--|
| 1. L.H. travel suction valve (A3 port) | 10. R.H. outrigger suction valve (B7 Port) |
| 2. L.H. travel suction valve (B3 port) | 11. Boom swing suction valve (Head side) (A8 port) |
| 3. Boom suction valve (Bottom side) (A4 port) | 12. Boom swing suction valve (Bottom side) (B8 port) |
| 4. Boom suction valve (Head side) (B4 port) | 13. 2-piece boom suction valve (A9 Port) |
| 5. Arm suction valve (Head side) (A5 port) | 14. 2-piece boom suction valve (B9 Port) |
| 6. Arm suction valve (Bottom side) (B5 port) | 15. Attachment suction valve (R.H. side) (A10 port) |
| 7. Bucket suction valve (Head side) (A6 port) | 16. Attachment suction valve (L.H. side) (B10 port) |
| 8. Bucket suction valve (Bottom side) (B6 port) | 17. Safety valve |
| 9. R.H. outrigger suction valve (A7 Port) | 18. Lift check valve |

4. Pressure compensation valve

FUNCTION

1. During complex operation, if the load pressure at one side becomes lower than that of the other actuator and the oil flow is about to increase, pressure compensation is carried out. (In this case, the other actuator (right side) of the complex operation has higher load pressure than that of this side (left side).

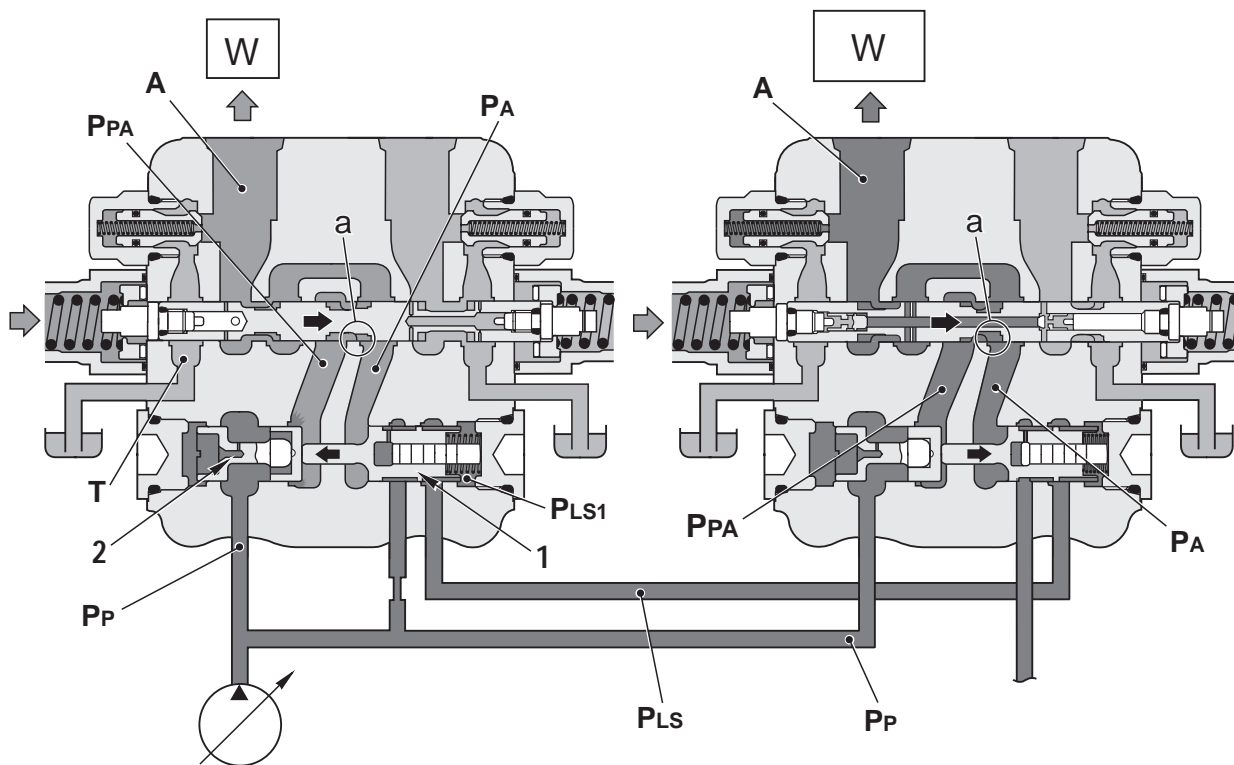

D0401095

OPERATION

- During complex operation, when the load pressure of the other actuator side (right side) becomes higher, the flow in the actuator circuit **A** at this (left) side tends to increase.
- In this case, the **LS** pressure **PLS** at the other actuator acts on the spring chamber **PLS1**, and pushes the pressure reducing valve (1) and the flow control valve (2) to the left (←) side.
- The flow control valve (2) throttles the opening area between the pump circuit **PP** and the upstream side of the spool **PPA**, and generates a pressure loss in between **PP** and **PPA**.
- The flow control valve and the pressure reducing valve (1) are balanced at the point where the differential pressure between **PA** and **PLS**, which act on the both end surfaces of the pressure reducing valve (1), becomes equal to the pressure loss in between **PP** and **PPA** before and after the flow control valve (2).
- By this operation, the differential pressures between the upstream pressure **PPA** and the downstream pressure **PA** of both spools in the complex operation are made same, and the pump flow is distributed in proportion to the opening areas of notches **a** of each spool.

SWIVEL JOINT

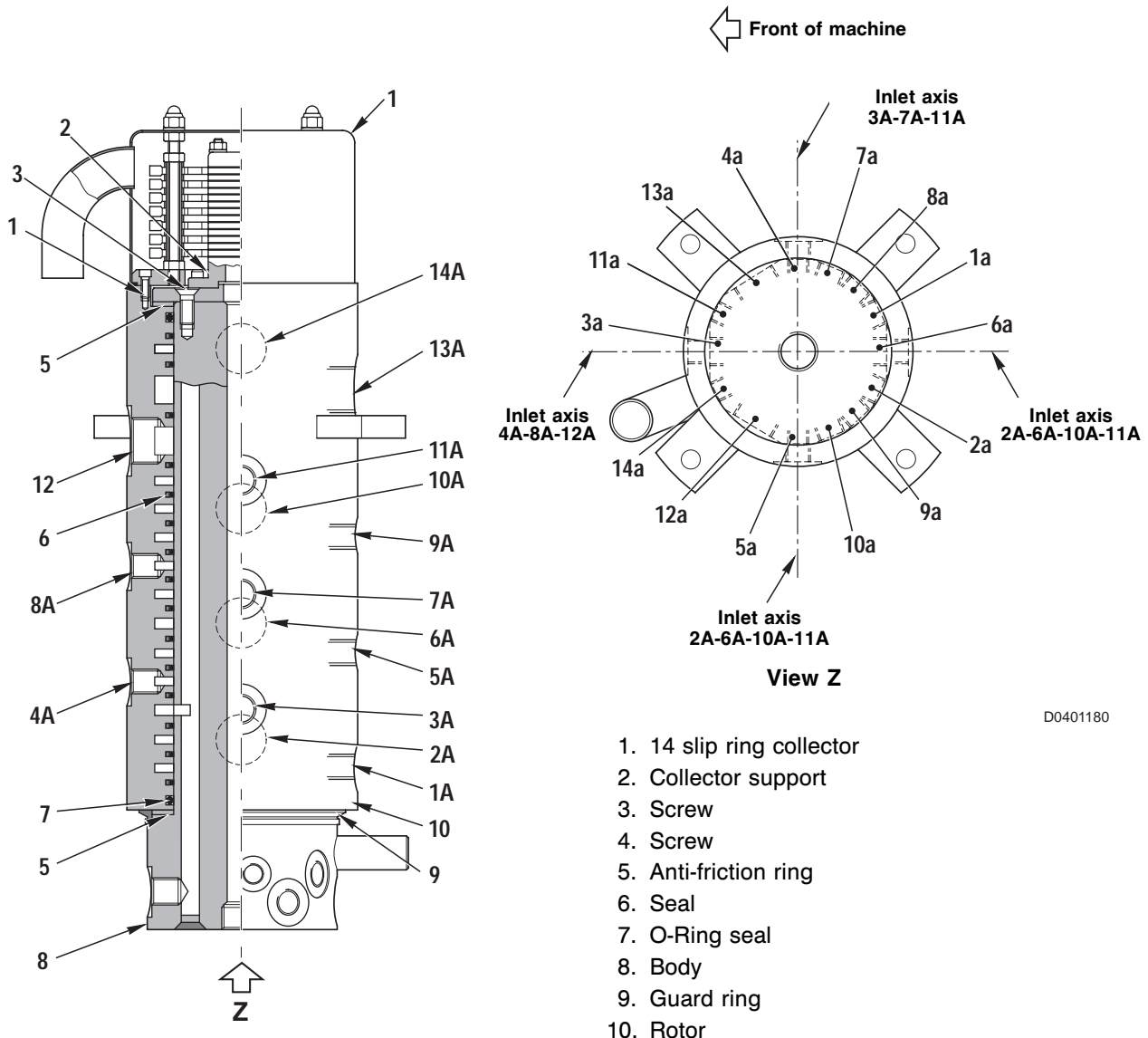

D0401180

- 1. 14 slip ring collector
- 2. Collector support
- 3. Screw
- 4. Screw
- 5. Anti-friction ring
- 6. Seal
- 7. O-Ring seal
- 8. Body
- 9. Guard ring
- 10. Rotor

- 1A. From steering unit (R Port)
- 2A. From steering unit (L Port)
- 3A. See hydraulic circuit
- 4A. From ST1 solenoid valve group (B2 Port)
- 5A. From ST2 solenoid valve group (B1 Port)
- 6A. To hydraulic tank
- 7A. From brake pump (T1 Port)
- 8A. From brake pump (T2 Port)
- 9A. See hydraulic circuit
- 10A. See hydraulic circuit
- 11A. From ST2 solenoid valve group (A Port)
- 12A. From control valve (B3 Port)
- 13A. To control valve (A3 Port)
- 14A. From ST2 solenoid valve group (A1 Port)

- 1a. See hydraulic circuit
- 2a. See hydraulic circuit
- 3a. See hydraulic circuit
- 4a. To brake cylinder
- 5a. To transmission (f Port)
- 6a. From travel valve (T Port)
- 7a. To axle brake
- 8a. To axle brake
- 9a. See hydraulic circuit
- 10a. See hydraulic circuit
- 11a. To locking axle cylinder (B Port)
- 12a. To travel motor (B Port)
- 13a. To travel motor (A Port)
- 14a. To transmission (e Port)

OPERATION

1. When engine is stopped

- Poppet (5) is pushed against the seat by spring (6), and the passage from Port **PR** → **T** is closed.
 - Valve (8) is pushed to the left by spring (7), and the passage from Port **P1** → **PR** is open.
 - Valve (2) is pushed to the left by spring (3), so the passage between Port **P1** → **P2** is closed.
- (See Fig. 1)

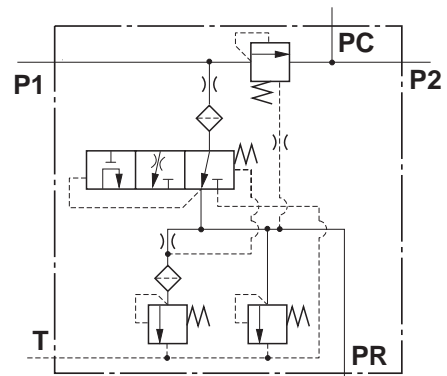

Hydraulic circuit diagram

D0400866

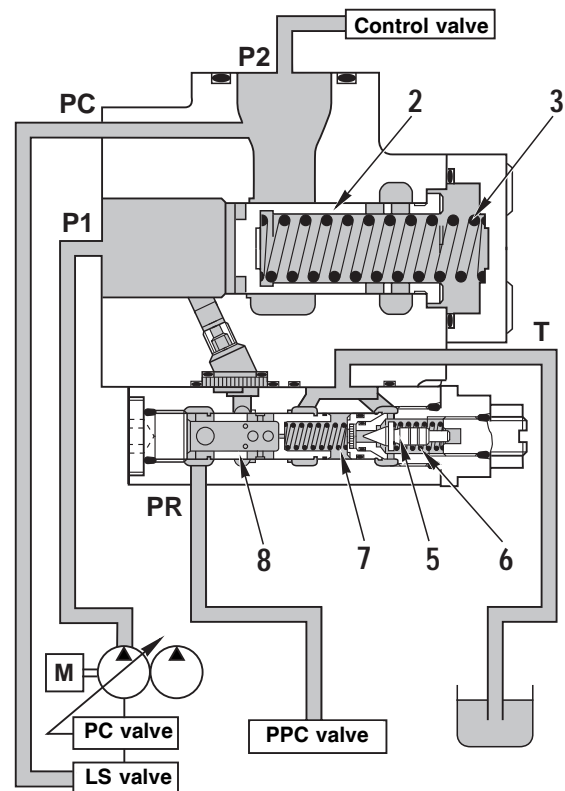
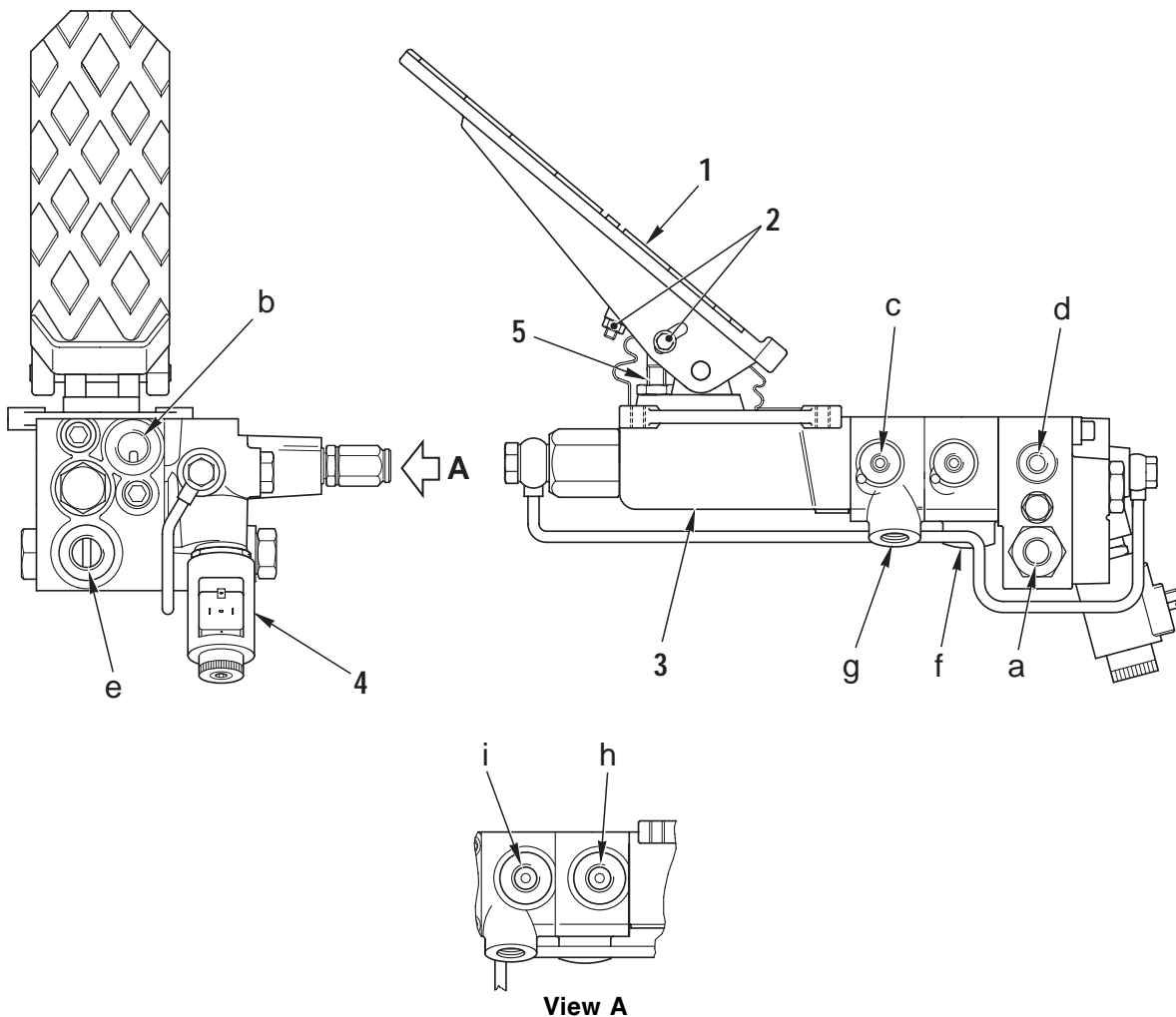

Fig. 1

D0400799

BRAKE PUMP



1. Pedal
 2. Pedal angle adjustment
 3. Pump
 4. Service brake locking solenoid valve (EVF3)
 5. Pedal movement adjustment
-
- a. P Port - From servocontrol feed unit (P2A Port)
 - b. N Port - To hydraulic tank
 - c. T1 Port - Brake light pressure switch port
 - d. F Port - Accumulator pressure switch port
 - e. B Port - To pump (PPLS Port)
 - f. R2 Port - To A1 accumulator
 - g. R1 Port - To A2 accumulator
 - h. T1 Port - To swivel joint (7A Port)
 - i. T2 Port - To swivel joint (8A Port)

SPECIFICATIONS

Circuit feed pressure: 70 ± 5 bar
 Unitary displacement: 70 cc

D0401175

Solenoid valve group OP3 (EV8 - EV9)

For breaker, rotating grab bucket control

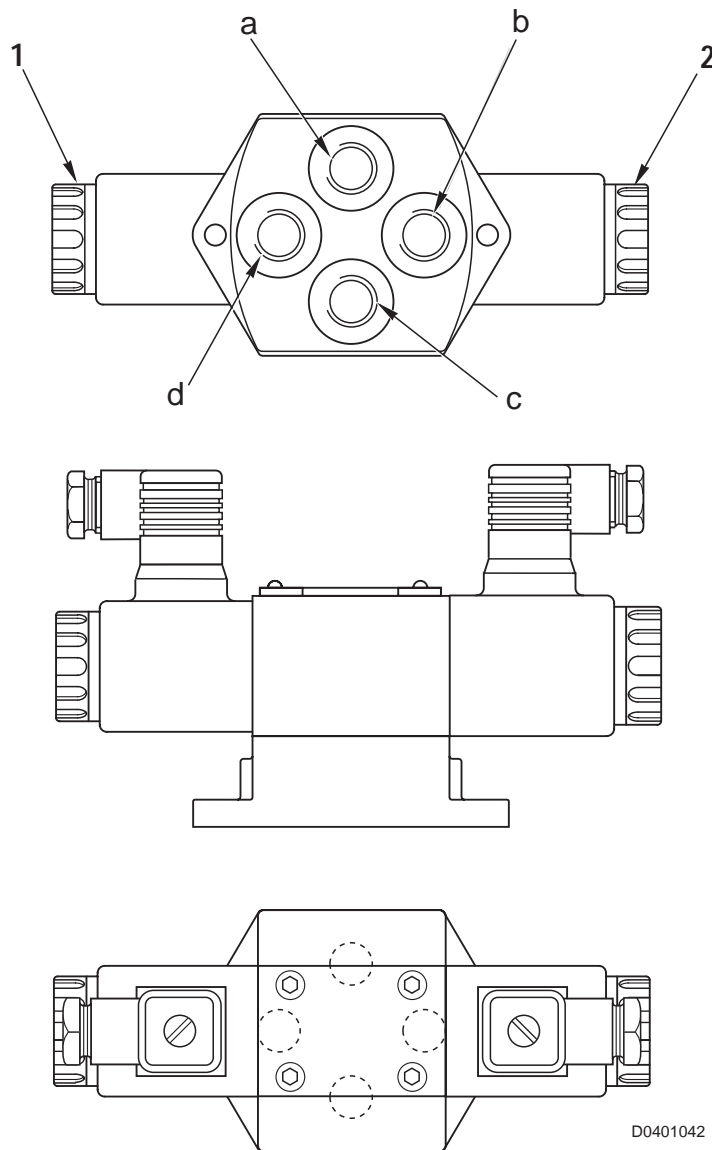

D0401042

1. EV9 L.H. optional equipments control
2. EV8 R.H. optional equipments control

- a. T Port - To hydraulic tank
- b. A Port - To control valve (PB₁₀ Port)
- c. P Port - From ST1 solenoid valve group (A4 Port)
- d. B Port - To control valve (PA₁₀ Port)

ELECTRICAL DIAGRAM (2WS) (10/10)

1	2	3	4	5	6	7	8	9	10	11	12	13	14	15	16	17	18	19	20
---	---	---	---	---	---	---	---	---	----	----	----	----	----	----	----	----	----	----	----

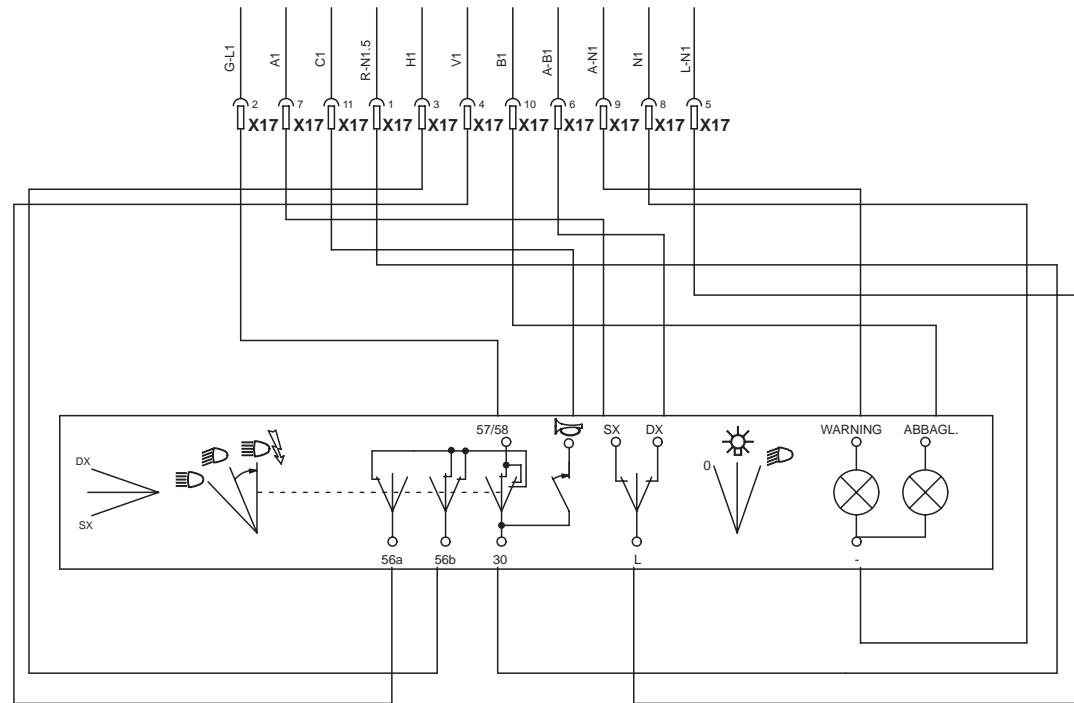

LIGHT SWITCH

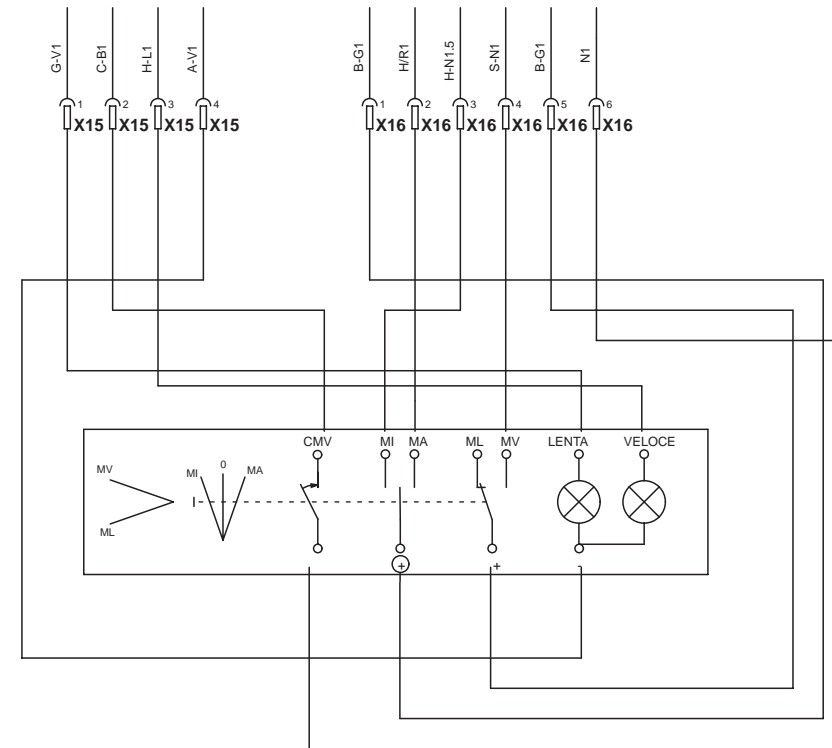

DRIVE SWITCH

CONNECTORS

- X15 - 4-way switch connector
- X16 - 8-way switch connector
- X17 - 12-way switch connector

D0401336

ELECTRICAL DIAGRAM (4WS) (10/10)

1	2	3	4	5	6	7	8	9	10	11	12	13	14	15	16	17	18	19	20
---	---	---	---	---	---	---	---	---	----	----	----	----	----	----	----	----	----	----	----

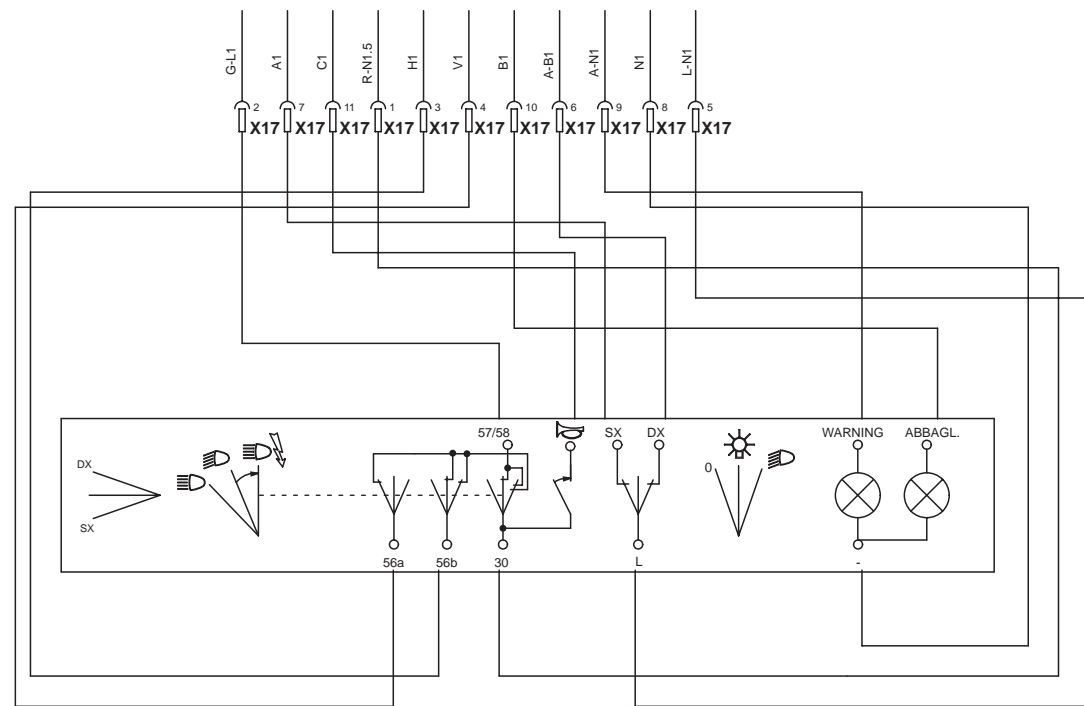

LIGHT SWITCH

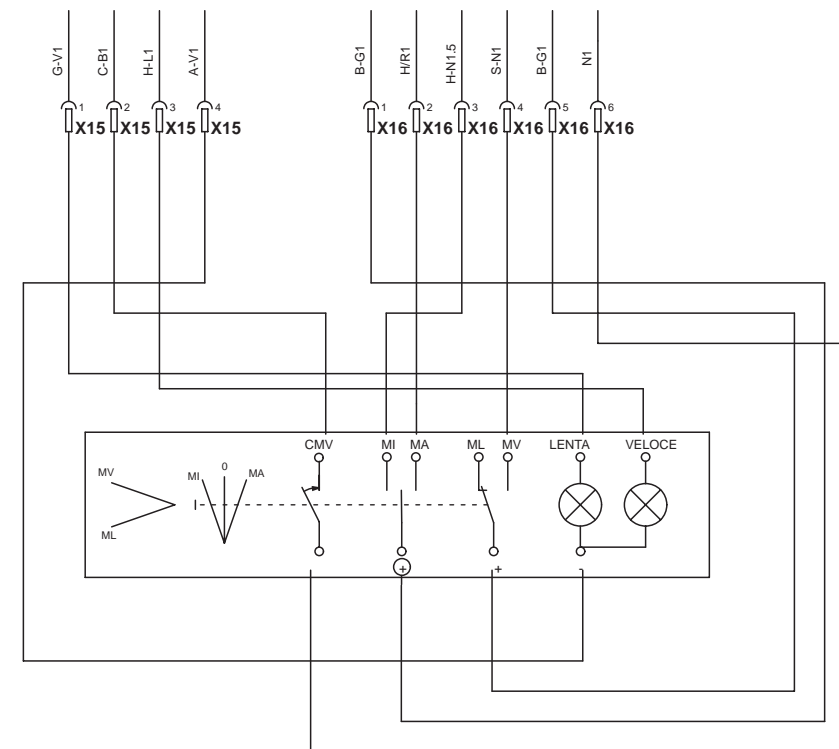

DRIVE SWITCH

CONNECTORS

- X15 - 4-way switch connector
- X16 - 8-way switch connector
- X17 - 12-way switch connector

● FOR MACHINE

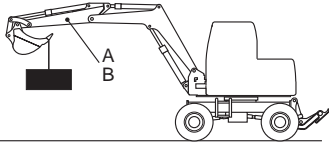
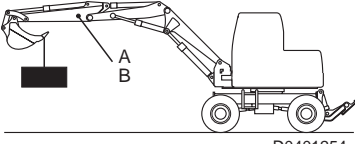
Machine model				PW75-1		
Classification	Check item	Test conditions	Unit	Standard value	Permissible value	
Hydraulic drift of working equipment	Total work equipment (Standard boom) (Downward movement bucket teeth tips)	 <p>D0401253</p>	Boom A	400	450	
			Boom B	400	450	
	Boom cylinder (Retraction)	<ul style="list-style-type: none"> In this position, measure extension or retraction of each cylinder, and any leakages occurring when a load is applied to the tips of the bucket teeth. Horizontal levelled ground Bucket: rated load (475 kg) Levers: neutral Engine: switched off Oil temperature: 45 – 55°C Safety valve disengaged Take measurements as soon as the engine stops Measure the variations every 5 minutes and check the total variation after 15 mins. 	Boom A	75	90	
			Boom B	80	100	
	Arm cylinder (Extension)		Boom A	50	60	
			Boom B	60	75	
	Bucket cylinder (Retraction)		30	40		
	Total work equipment (Downward movement of tips of bucket teeth) (2-piece boom)		 <p>D0401254</p>	Boom A	600	800
		Boom B		600	800	
		Boom cylinder (Retraction)		Boom A	80	100
				Boom B	90	115
		2 nd boom cylinders (Retraction)		Boom A	60	75
				Boom B	75	100
		Arm cylinder (Extension)		Boom A	50	60
Boom B				60	75	
Bucket cylinder (Retraction)	30	40				

SPECIAL TOOLS

Measurement check points	Symbol		Code	Name	Q.ty	Remarks
Valve clearance - Adjusting parking brake	A	1	Commercially available	Feeler gauge	1	—
Compression pressure	B	1	ATR800090	Compression gauge	1	0-70 kg/cm ²
		2	ATR800130	Adapter	1	—
Engine speed	C	1	ATR800070	Multi-scale tachometer	1	20 - 4000 rpm
		2	ATR800060	Stroboscopic tachometer	1	6 - 30000 rpm
Water and oil temperature	D	1	Commercially available	Digital temperature gauge	1	- 50 - 1200 °C
Hydraulic pressures and deliveries	E	1	ATR800170	Pressure gauge	2	Full scale 60 bar
		2	ATR800150	Pressure gauge	1	Full scale 250 bar
		3	ATR800140	Pressure gauge	1	Full scale 400 bar
		4	ATR800010	Pressure gauge	1	Full scale 600 bar
		5	ATR800200	Sensocontrol kit (Differential pressure gauge)	1	—
	F	1	ATR800120	Flowmeter	1	—
		2		Tube union kit	1	
Thickness of brake disks	G	1	ATR500930	Feeler gauge	1	4.5/4.3 (T23 CK)
Drift test	H	1	ATR200380	Tool for checking drifts and brake line	1	—
		2	ATR201310	Union kit	1	—
Parking brake	L	1	Commercially available	Dynamometer	1	Full scale 20 kg

ADJUSTING THE SAFETY MICROSWITCH

★ Test conditions:

- Engine: switched off but at working temperature.
- Hydraulic oil: 45 – 50°C.

1 - Unscrew the nut (1) that secures the microswitch (2).

2 - Tighten or unscrew the microswitch (2) to the extent indicated.

- ★ Projection of microswitch: 16 ± 1 mm

3 - Secure it in position with the nut (1).

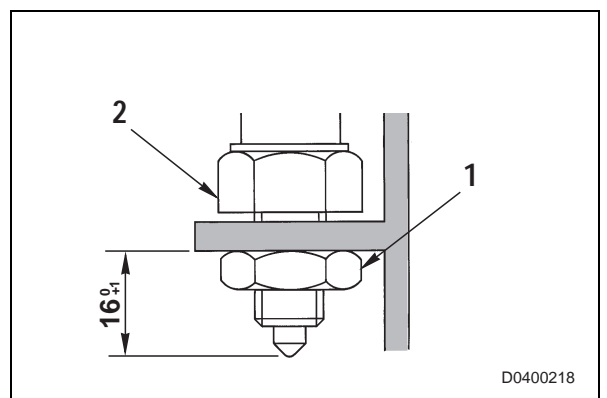
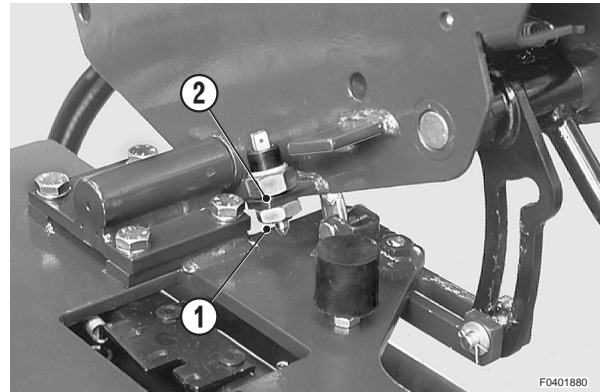

MEASURING LS DIFFERENTIAL PRESSURE AND ADJUSTING LS VALVE

1. Measuring ΔP_{LS} differential pressure

1 - Measurement using a differential pressure gauge E5.

- i) Remove the oil pressure measurement plug (1) (PT 1/8) and connect an adapter (2).
- ii) Connect the pressure gauge E5 to adapter (2) on control valve and to adapter M1 (delivery pump P1).
- iii) Measure the ΔP_{LS} differential pressure according to the conditions shown in table 1.

Table 1

Work mode	Fuel lever	Operation	Differential pressure bar (kg/cm ²)
P	Full	Lever at NEUTRAL	25 - 39 (25 - 40)
P	Full	Travel speed: Hi Travel idling (lever full)	21 ± 1 (21.5 ± 1)

NOTE: Raised machine - Front axle locked.

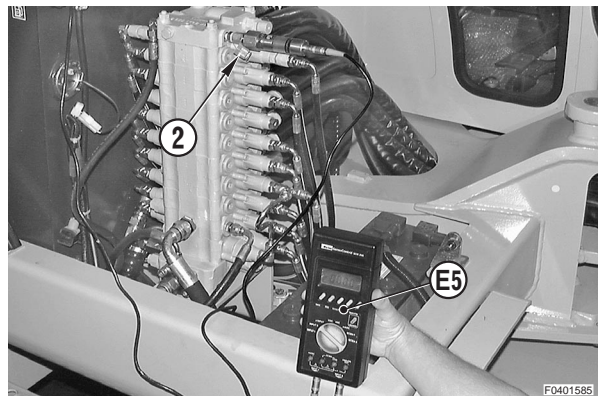
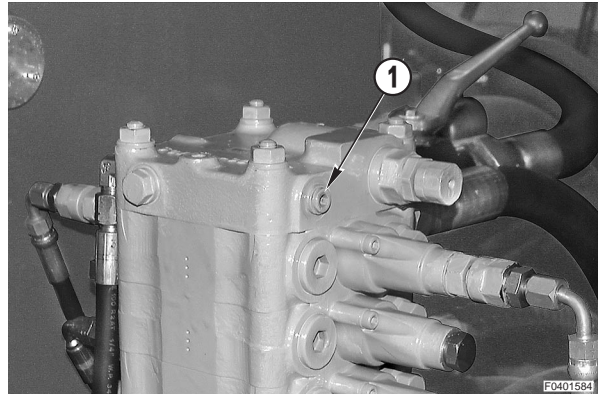

2 - Measurement using a hydraulic pressure gauge E3.

- ★ Use a same gauge.
- i) Remove the oil pressure measurement plug (1) (PT 1/8) on control valve and connect an adapter (2).

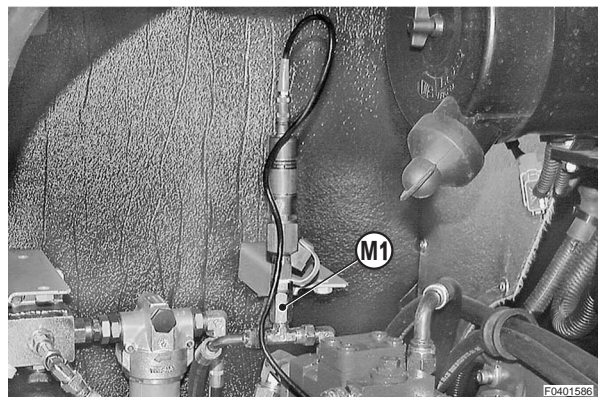

- ii) Connect the pressure gauge E3 (400 bar) to adapter M1 of pump.
 - ★ Reading of the gauge shall be 10 bar.
 - ★ If a pressure gauge of 400 bar is not available, may be used one of 600 bar.
- iii) Measure the pump discharge pressure according to the conditions shown in table 1.
 - ★ Stand directly in front of the indicator and be sure to read it correctly.

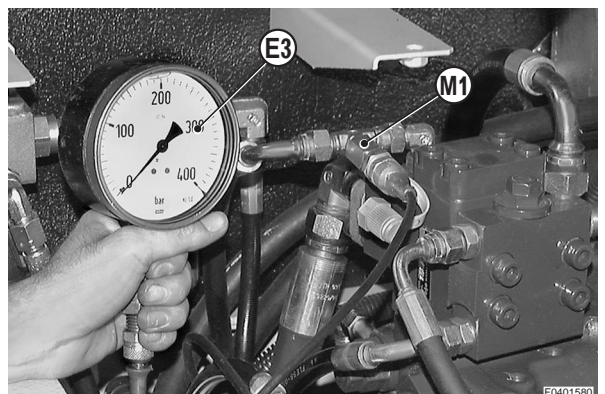

3. Check the leaktightness of the hydraulic braking circuit

- 1 - Connect the pressure gauge **E2** (250 bar) to the adapter of the braking line **M6**.
 - 2 - Start the engine and put it into low idling.
 - 3 - Execute several braking actions to empty the accumulators and then recharge them completely (150⁰+5 bar).
 - 4 - Stop the engine and return the ignition key to position «I» in order to supply voltage to the electric circuits.
 - 5 - Use the working brake engagement button to execute a braking action.
 - 6 - Watch the pressure shown by pressure gauge **E2** for two minutes. During this period the pressure value should not vary with respect to the first reading.
- ★ If variations in the braking pressure are observed, verify in the following sequence:
- 1 - Any visible leakages in the system.
 - 2 - Internal leakages in the swivel joint (For details, see «MEASUREMENT OF INTERNAL OIL LEAKAGES IN THE SWIVEL JOINT»).
 - 3 - The leaktightness of the brake groups (For details, see «4. Checking the leaktightness of the brake groups»).

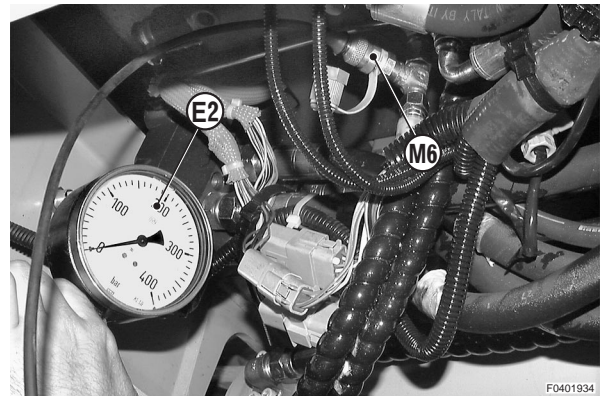

4. Checking the leaktightness of the brake groups

This test envisages two phases:

- 1 - Identification of the defective axle.
- 2 - Identification of the defective brake group.

Identification of the defective axle

We shall describe here the procedure for the axles is identical.

- 1 - Release all residual pressure in the accumulators.
- 2 - Disconnect the flexible hose (12), leading out of the swivel joint (branch 7 for front axle, branch 8 for rear axle), from the rigid front axle supply tube (11) (on the LH side of the lower frame).
- 3 - Insert apparatus **H1** between the two tubes, connecting it in such a way that the cut-off cock (13) is connected to the flexible hose leading out of the swivel joint.

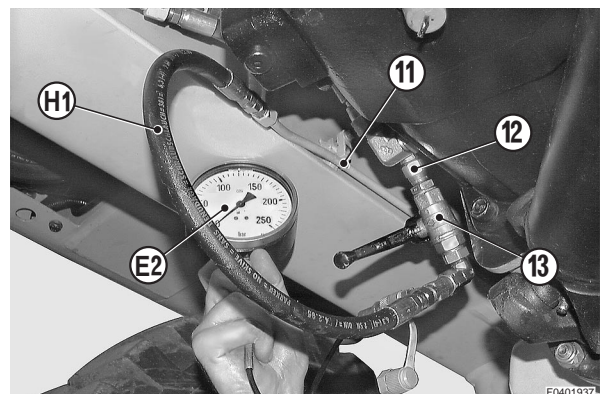

ADJUSTMENT OF THE SPEED SURVEYOR

When dismantling or substituting the speed surveyor, proceed as follows for the final positioning:

1 - Screw the sealing washer (2) onto the sensor (1) and screw the sensor (1) into the casing of the transmission (3) by hand until it rests on the toothed wheel (4).

★ Check the condition of the sealing washer (2) with care.

2 - Unscrew the sensor (1) until a space of $0.5^{+0.2}$ mm is obtained between the sensor and the toothed wheel (4) ($0.5 \div 0.6$ turns).

3 - Secure the sensor with the nut (5).

 Lock nut: 22 ± 2 Nm

4 - Connect the electric cabling and mount the protective rubber sleeve (6).

 Turn the protective sleeve (6) so that the cable opening points towards the ground, in order to prevent accumulations of water or condensates.

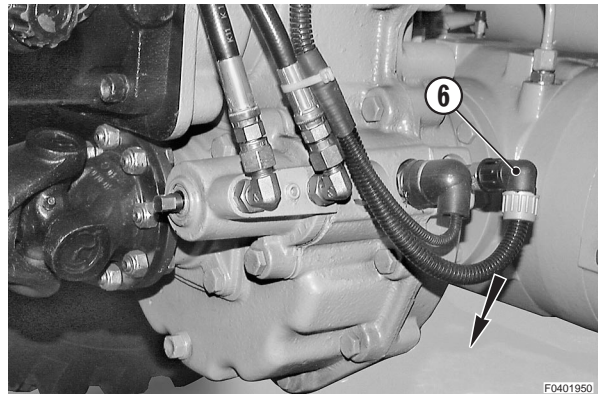
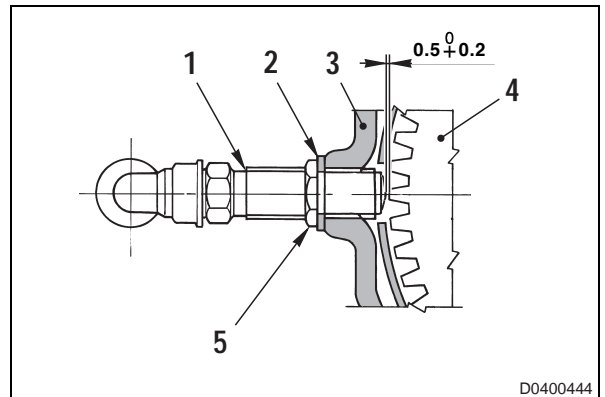

CLICK HERE TO **DOWNLOAD** THE COMPLETE MANUAL

- Thank you very much for reading the preview of the manual.
- You can download the complete manual from: www.heydownloads.com by clicking the link below



- Please note: If there is no response to CLICKING the link, please download this PDF first and then click on it.

CLICK HERE TO **DOWNLOAD** THE COMPLETE MANUAL

4. 2nd boom test

- 1 - Position the machine with the arm and the 2nd boom completely extended. Rest the bucket teeth on the ground.
- 2 - Stop the engine and release any residual hydraulic pressures.

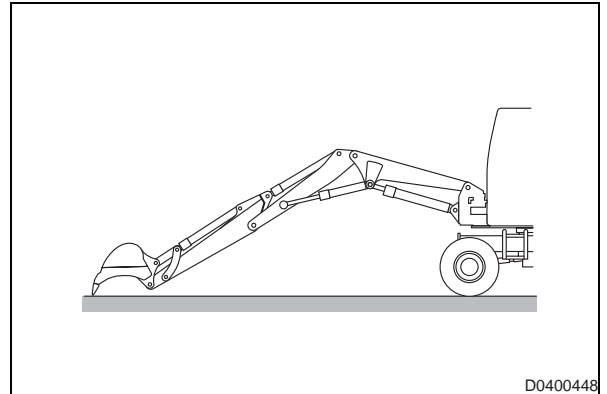

D0400448

- 3 - Disconnect the two pipes (1) and (2) and cap them to prevent entry of impurities.
 - ★ If a safety valve has been installed, remove it.
- 4 - Cap the cylinder couplings on the bottom side and attach provisional hoses on the head side to collect any leaking oil.

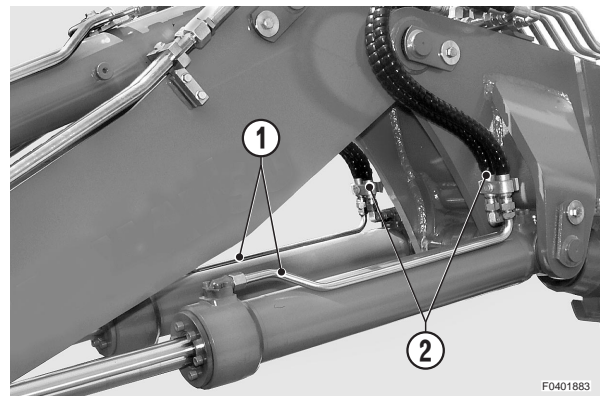

F0401883

- 5 - Start the engine and raise the boom.
- 6 - Stop the engine and check the position of the 2nd boom for 5 minutes.
 - If the 2nd boom closes, the drift is due to the cylinder gasket.
 - If the 2nd boom does not close, the drift is due to the control valve.

To check one cylinder at a time, proceed as follows:

- 7 - Rest the bucket on the ground and release any residual hydraulic pressures.
- 8 - From one cylinder remove the cap mounted on the bottom side during phase 4.
- 9 - Start the engine, raise the boom and then stop the engine.
- 10 - Check the position of the 2nd boom for 5 minutes.
 - If the 2nd boom closes, the drift is due to the gaskets of the cylinder that has been capped.
- 11 - Repeat the operation from phase 8 to phase 10 to test the other cylinder.

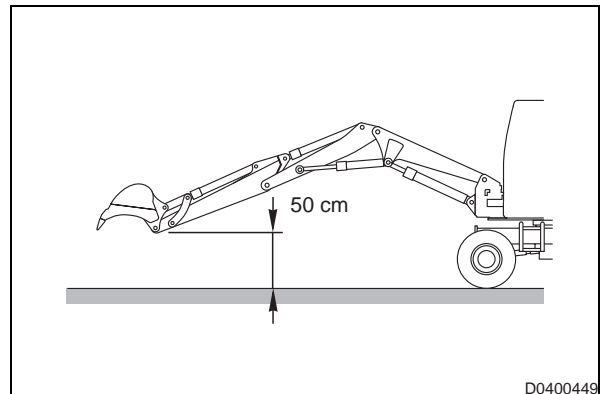

D0400449

BRAKE PUMP		ARM CYLINDER	
Removal and installation.....	60	Removal and installation.....	147
STEERING UNIT		BUCKET CYLINDER	
Removal and installation.....	61	Removal and installation.....	148
Disassembly.....	62	BOOM SWING CYLINDER	
Assembly.....	68	Removal and installation.....	149
PRIORITY VALVE		OUTRIGGER - BLADE CYLINDER	
Removal and installation.....	78	Removal and installation.....	150
Assembly e disassembly.....	79	WORK EQUIPMENT CYLINDER	
TRAVEL MOTOR		Disassembly.....	151
Removal.....	80	Assembly.....	152
Installation.....	81	UPPER WORK EQUIPMENT	
Disassembly.....	82	(1-piece boom)	
Assembly.....	85	Removal and installation.....	156
TRANSMISSION		UPPER WORK EQUIPMENT	
Removal and installation.....	90	(2-piece boom)	
Disassembly.....	91	Removal.....	157
Assembly.....	98	Installation.....	158
AXLE LOCKING CYLINDER		BUCKET	
Removal and installation.....	105	Removal and installation.....	159
FRONT AXLE		ARM	
Removal.....	106	Removal.....	160
Installation.....	108	Installation.....	162
REAR AXLE		2-PIECE BOOM	
Removal.....	109	Removal.....	163
Installation.....	111	Installation.....	164
AXLES		BOOM (1-piece boom)	
Disassembly.....	112	Removal and installation.....	165
Assembly.....	124	BOOM (2-piece boom)	
BOOM CYLINDER (1-piece boom)		Removal.....	166
Removal and installation.....	142	Installation.....	167
BOOM CYLINDER (2-piece boom)		SWING BRACKET	
Removal.....	143	Removal and installation.....	168
Installation.....	144	BLADE AND OUTRIGGERS	
2-PIECE BOOM CYLINDER		Removal and installation.....	169
Removal.....	145	BLADE AND OUTRIGGER ARMS	
Installation.....	146	Removal and installation.....	170

6 - Disconnect control cable (13) from accelerator lever (12).

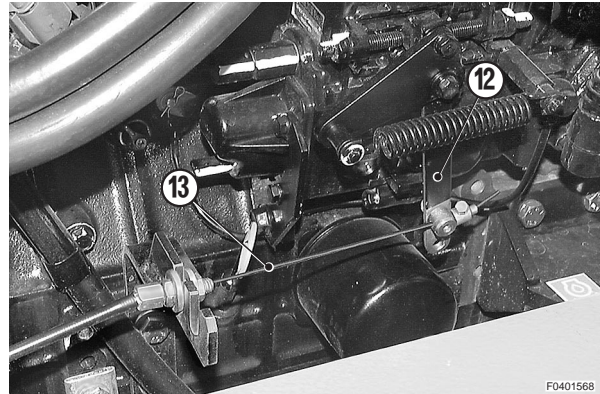

7 - Remove the bolt and bracket (14) of injection pump lubricating pipe.

8 - Remove injection pump lubricating pipe (15). ※4

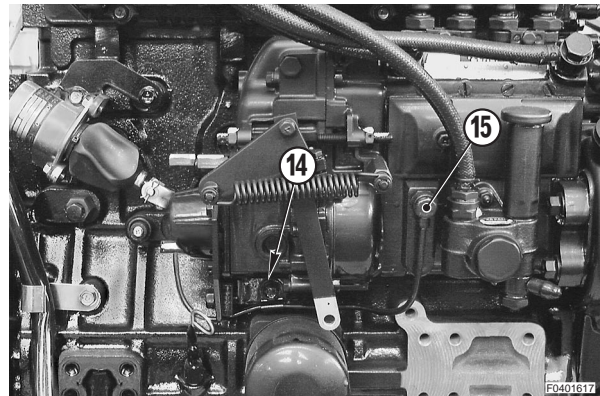

9 - Remove coolant tank support (16).

10 - Remove fan guard (17).

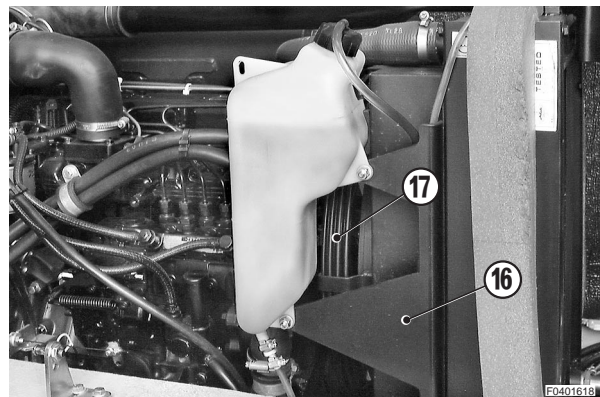

11 - Remove the inlet cover (18) to ignition gear system and the filler oil plug (19). ※5

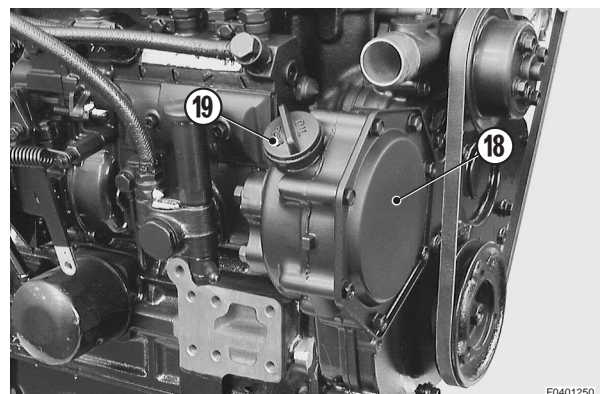

REMOVAL OF FRONT HOOD

! Lower the work equipment until it is resting on the ground and switch off the engine.

1 - Detach the gas cylinder (2) from the support (1).

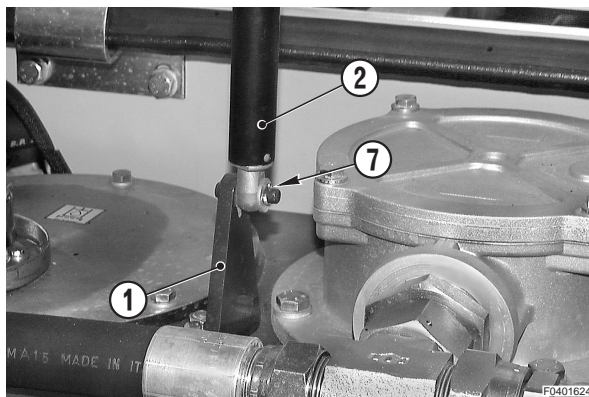

2 - While holding up the hood (3) remove the screws (4) that attach the hood (3) to the hinges (5).

※ 1

★ Mark the position of any shims.



Engine hood:..... kg

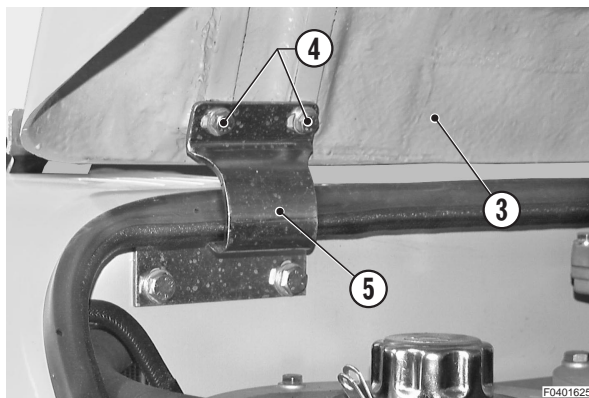

INSTALLATION OF FRONT HOOD

• To install, reverse the removal procedure.

※ 1

★ Check the centering and adjustment of the closing hook (6).

★ Position any shims.



Replace the cotter pins (7).

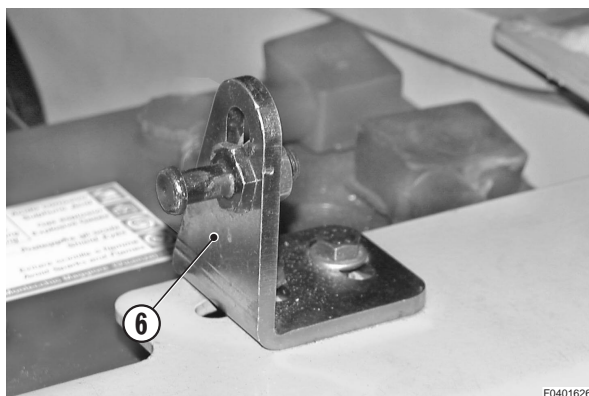



INSTALLATION OF ENGINE-PUMP GROUP

- To install, reverse the removal procedure.

※ 1

- ★ Before connecting the flanges, check the state of seals and keep them in position by applying grease ASL800050.

 Piston pump flange screws:
63±6.5 Nm (6.5±0.6 kgm)

 Gear pump flange screws:
35±3.5 Nm (3.6±0.3 kgm)

※ 2

 Supports central screws: 157 Nm (16 kgm)

- 1 - Fill the hydraulic tank up to its maximum level.

 While filling the tank, bleed air from pump.
(For details, see «20. TESTING AND ADJUSTMENTS»).

 Hydraulic oil needed: approx. 70 ℓ

- 2 - Fill the cooling circuit up to its maximum level.

 Coolant liquid needed: approx. 18 ℓ

- 3 - Start the engine to circulate oil and coolant liquid, and check that there are no leakages.
- 4 - Switch off the engine, check the levels and, if necessary, top them up.

5 - Remove No. 2 sun gear (15), ring gear (16) and remove No. 2 carrier assembly (17).

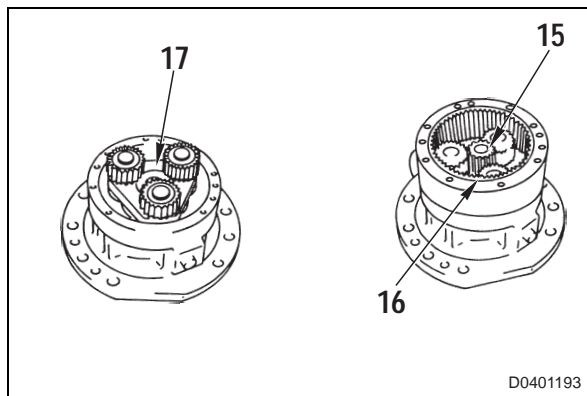

D0401193

6 - Remove snap ring (18), then remove thrust washer (19), gear (20), bearing (21) and thrust washer (22). Knock in pin (23) and remove shaft (24).

★ After removing the shaft (24), remove pin (23). Remove thrust washer (25) from carrier (26).

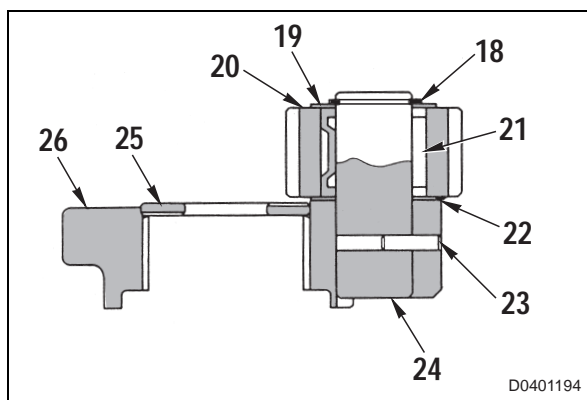

D0401194

7 - Set shaft and case assembly (27) to press, and push bearing (28) with tool L1.

★ Operate the press slowly and push the bearing to a point where the split collar (29) can be removed. Remove split collar (29).

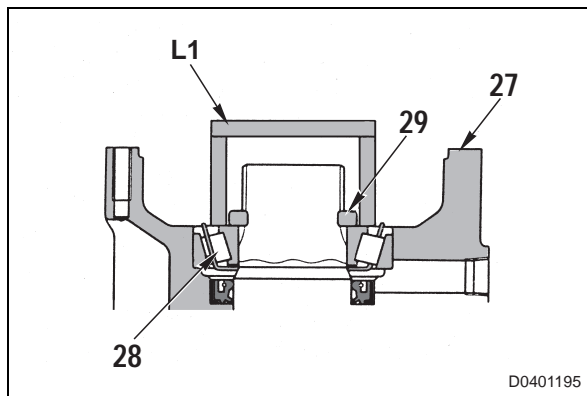

D0401195

8 - Set block L2 to shaft and case assembly (27), and using push tool L3, remove shaft assembly (30) with press.

Remove bearing (28).

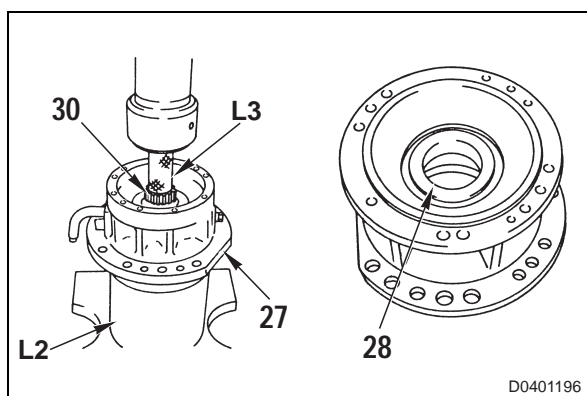

D0401196

REMOVAL OF THE TRANSMISSION - REVERSER, DIRECTION INDICATOR AND HEADLIGHT DIPPER BEAM CONTROL GROUP

! Lower the work equipment until it rests on the ground and stop the engine.

! Disconnect the lead from the negative (-) battery terminal.

- 1 - Take out check screws (1) (No. 2) and remove the front guard (2) of the steering column.
- 2 - Free cables from clamps and disconnect the connectors (3).
- 3 - Remove the two connecting screws (4) of the switching groups (5-6).
- 4 - Remove the RH half-clamp (7).
- 5 - Remove the LH half-clamp (8). ※ 1
- 6 - Remove the switching group (5 and 6) complete with wiring assemblies.

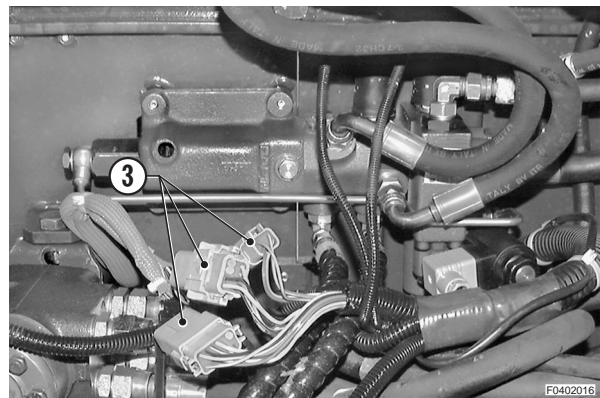
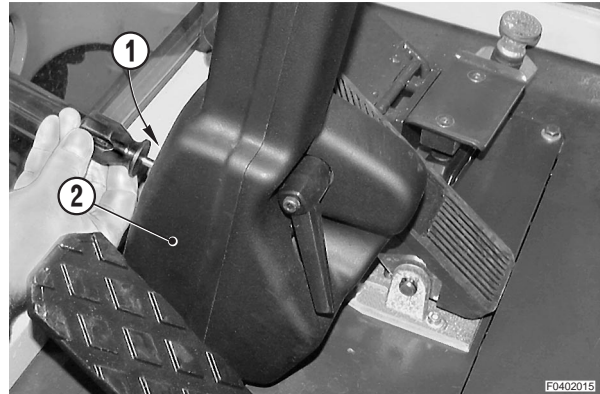

INSTALLATION

- To install, reverse the removal procedure.

※ 1

- ★ Check that the reference pin (9) can be fully inserted into the steering column (10) and that the R.H. half-clamp (7) adheres perfectly.

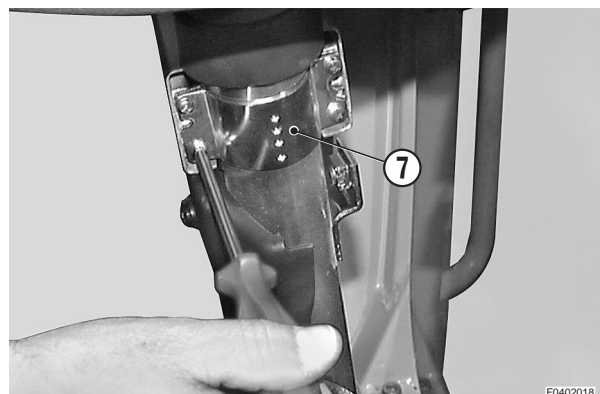
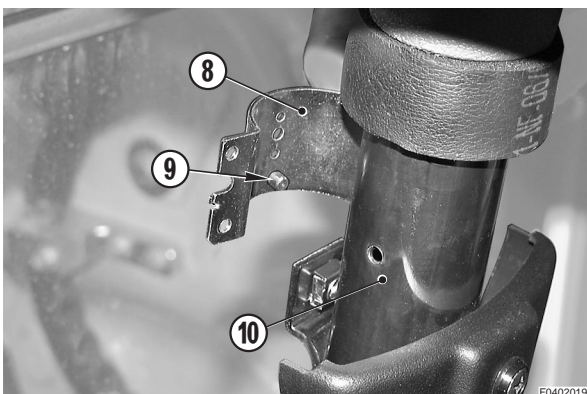
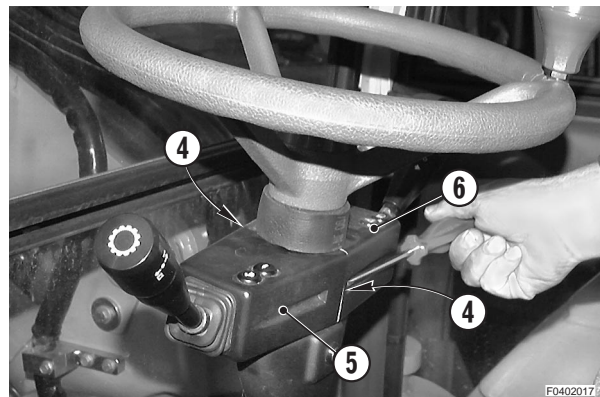

DISASSEMBLY THE STEERING UNIT

Disassembly the body of the steering unit

1 - Loosen and remove the screws (1-3) that hold the cover (2) in place (six screws plus one special screw).

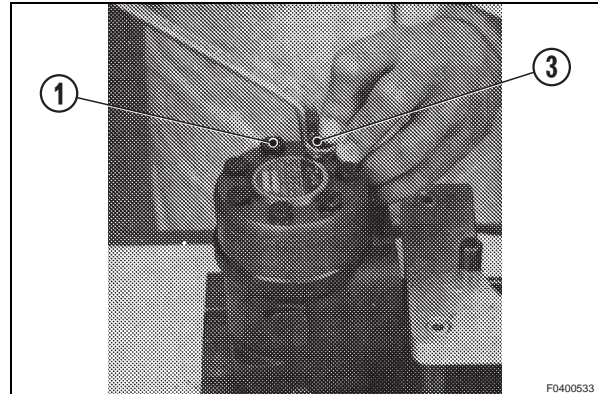

2 - Remove the cover (2) by sliding it sideways.

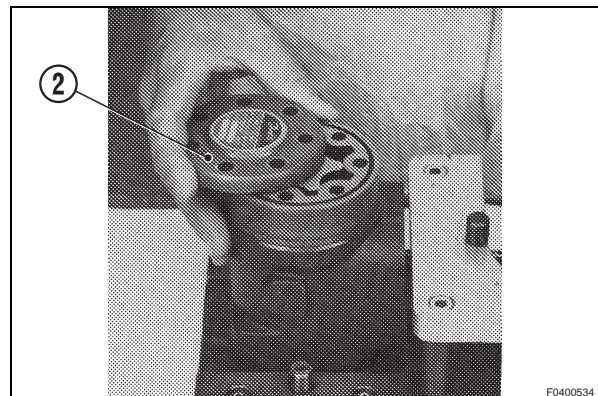

3 - Raise the rotating gear (4) complete with the O-rings (34). Also remove the spacer (5).

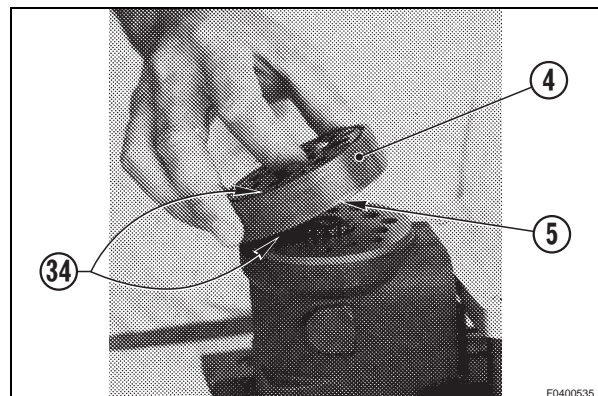

4 - Remove the drive shaft (6).

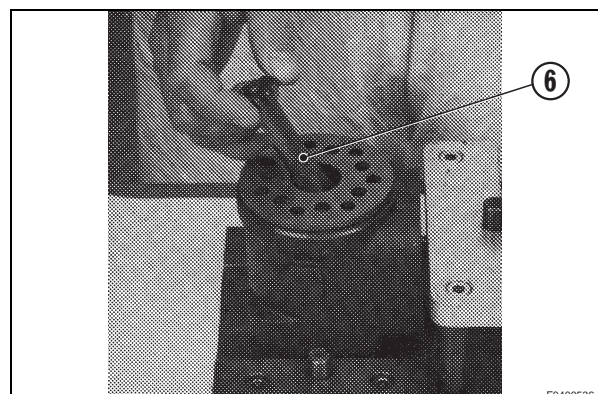

17 - Push the group (13) as far as it will go in order to push out the push rod that was left in position during phase 15.

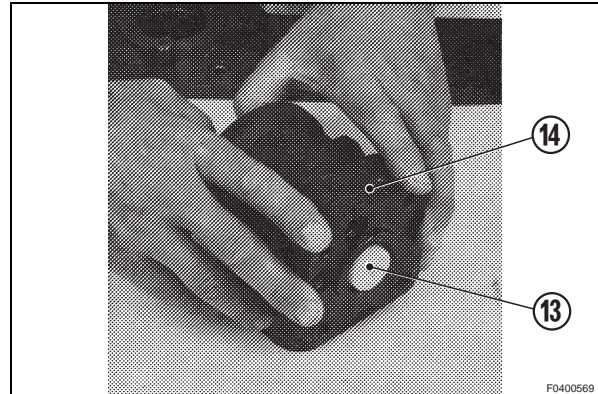

18 - Rotate the body of the steering unit (14) until the central hole is vertical. Insert the ball (10) of the safety valve into the hole indicated by the arrow.

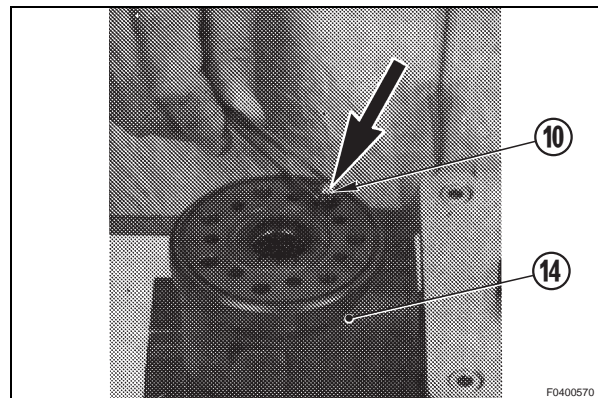

19 - Screw the valve threaded bush (8) into the hole in the safety valve.

- ★ The upper part of the threaded bush should be lower than the surface of the body of the steering unit (14).

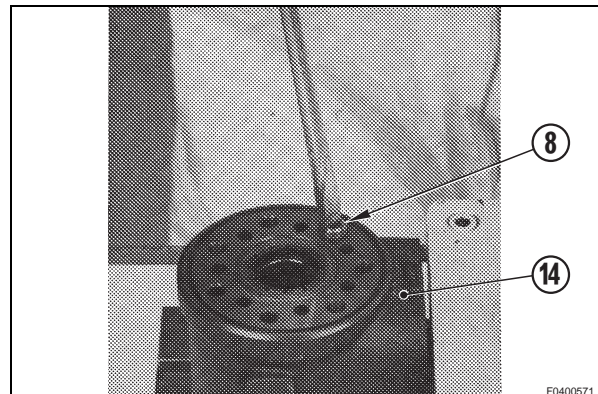

Assembly of the anticavitation valve

20 - Insert the balls (12) into the two holes indicated by the arrows.

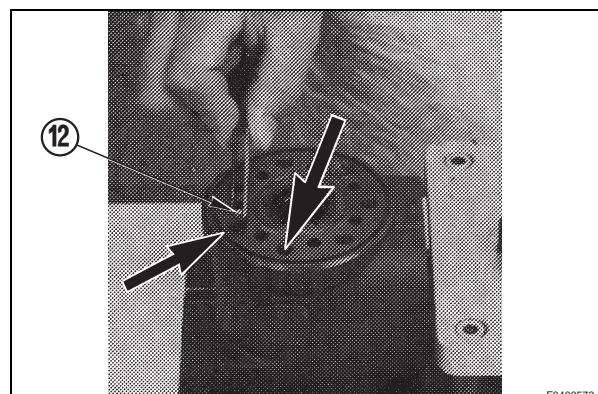

DISASSEMBLY OF THE TRAVEL MOTOR

1 - Remove circlip (1) and spacer (2).

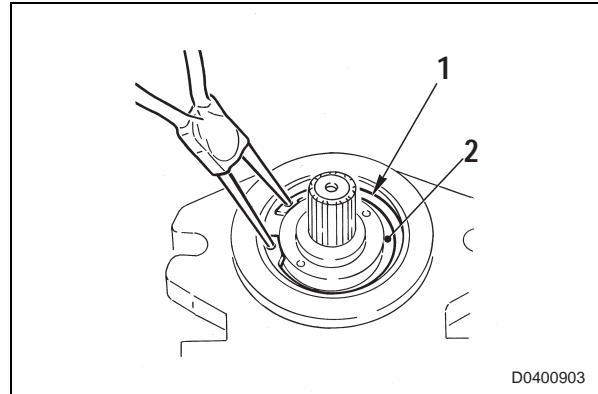

D0400903

2 - Install two screws in gasket (3) holes and extract it using pliers.

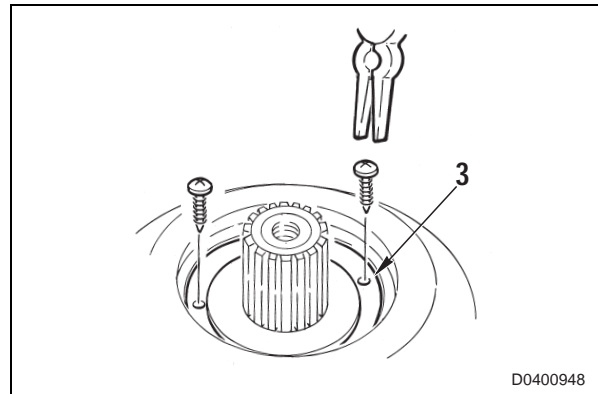

D0400948

3 - Remove oil exchange valve (4).

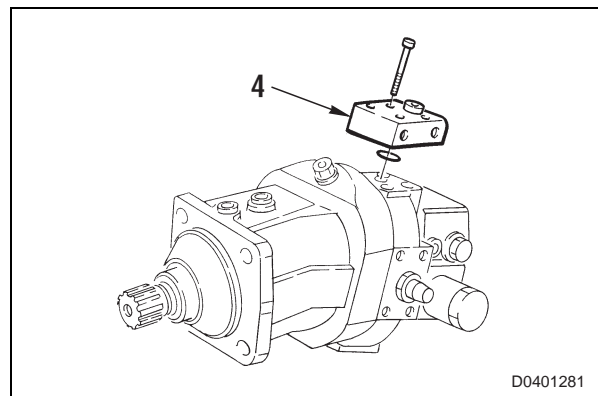

D0401281

4 - Remove recognition of travel direction device and automatic displacement device (5), guide pin (6), spring (7), bushing (8) and spring (9).
Remove brake valve (35).
Remove safety valve (36) (n° 2).

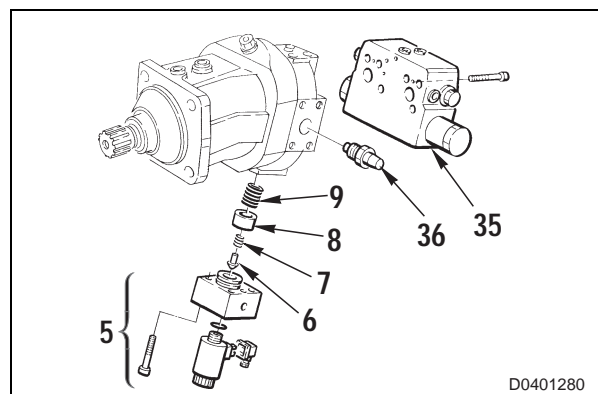

D0401280

2 - Remove the gear control cylinder assembly (7) and guard plate (8).

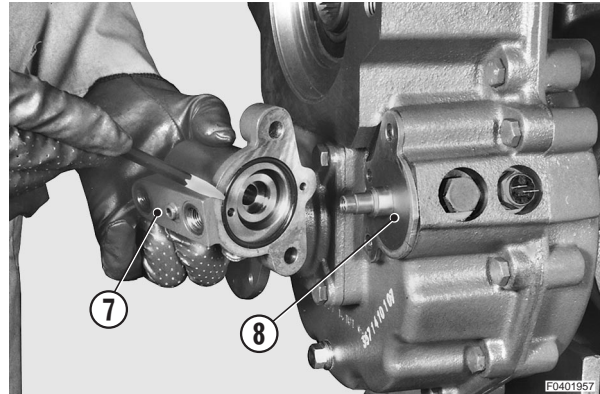

3 - Disassemble the gear control cylinder (7).
★ Check carefully the O-rings position.
★ Arrange the components in reassembly order.

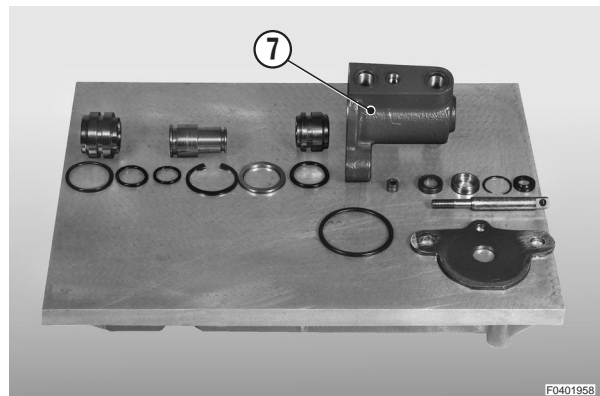

4 - Remove the breather (3) and mount the eyebolt (A).
Apply a slight tension to the chain and remove the screws fixing the gear box (B) to the axle (C).

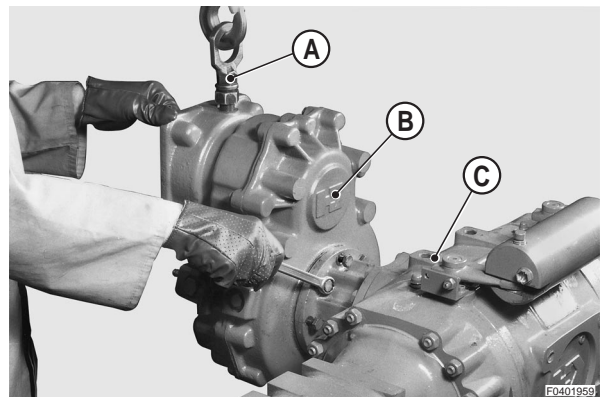

5 - Using a plastic hammer, remove the gear box (B).

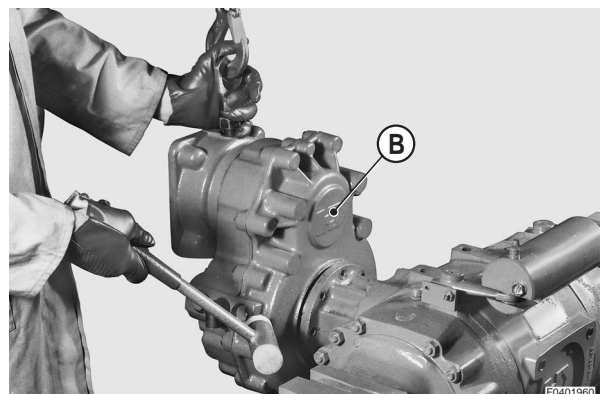

16 - Hook transmission (B) to the hoisting equipment and fit it onto axle (C).

Coat supporting surfaces.

Bolt units with the relative screws.

 Surfaces: Loctite 510

 Screws: Loctite 270

 Screws: 52 – 63 Nm

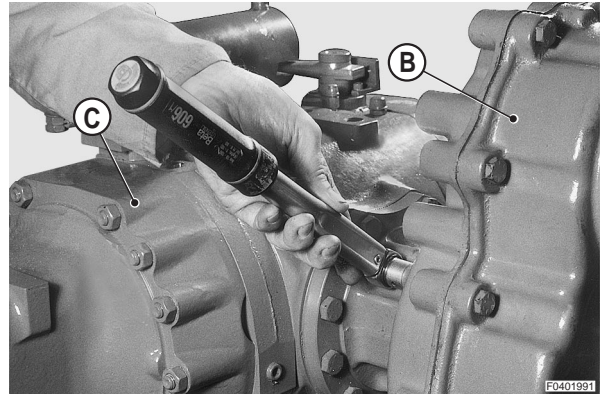

17 - Pull out screws and remove the provisionally fitted cover (19).

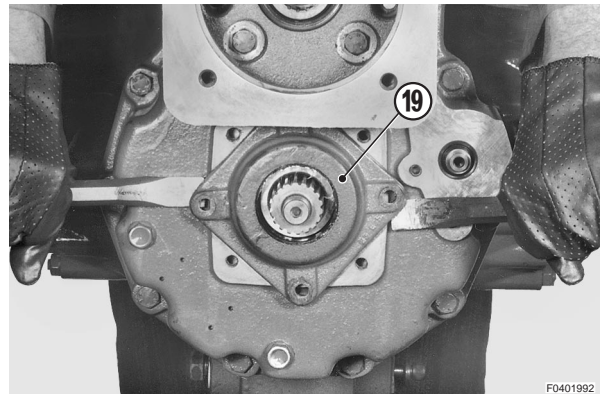

18 - Push the bearing (21) to end of travel.

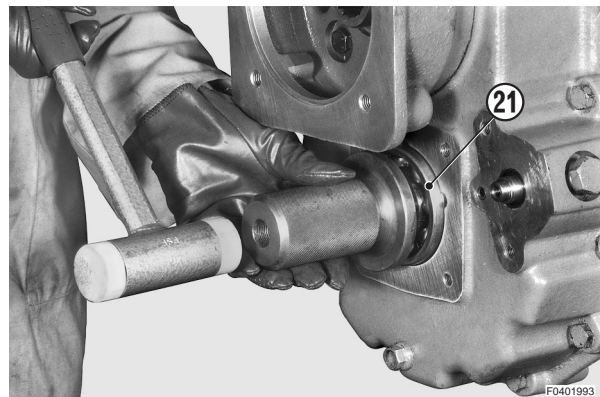

19 - Using a depth gauge, measure jut «A» of bearing (21) on flange surface.

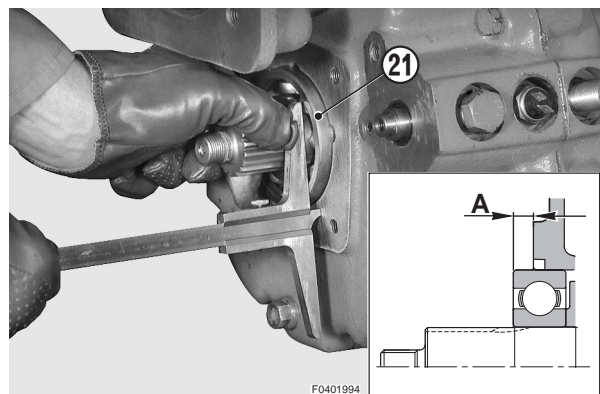

DISASSEMBLY OF AXLES

1. Final reducing unit

- 1 - Loosen the screws (1) and remove the support of the planetary gears (2).

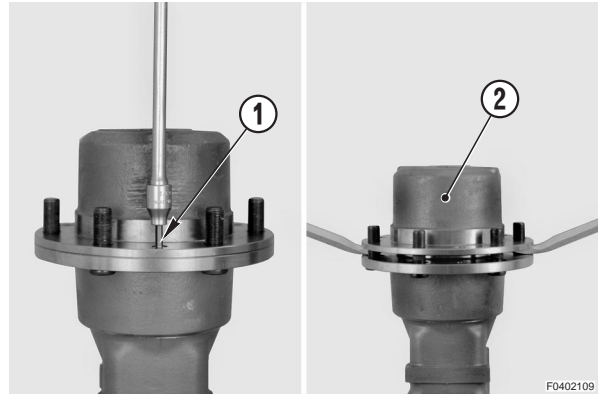

- 2 - Take away the snap ring (3).
Using a press, remove the planetary carrier pins (4).
Remove the planetary gears (5) complete with their roller bearings and cup springs.

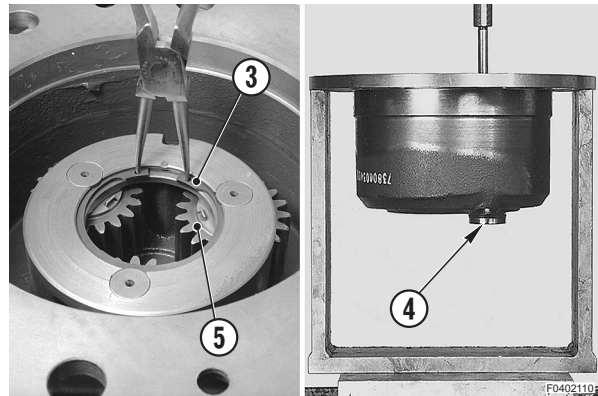

- 3 - Loosen screws (7) (No. 8).
Only for 2WS rear axle
Loosen brake clearance adjusting screws (No. 3 on each side) all the way and then remove the axle shaft (6). Loosen screws (7) (No.8).

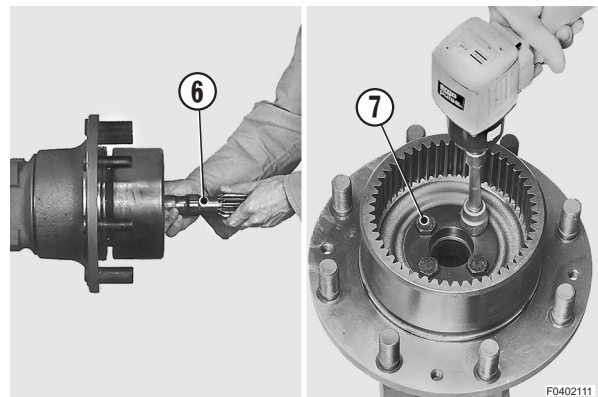

- 4 - Use a puller to remove the toothed ring bevel gear (8) and the wheel hub (9).

- ★ Use the slightly loosened retaining screws of the toothed ring bevel gear and a plate as a supporting surface for the puller.

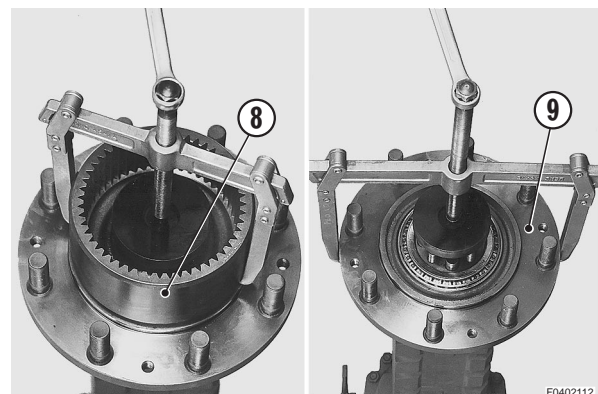

- 3 - Remove the roller bearing (63) from the bevel pinion.
From the main body (66) extract the thrust blocks of bearings (63) and (67), the shim (68) and the sealing ring (75).

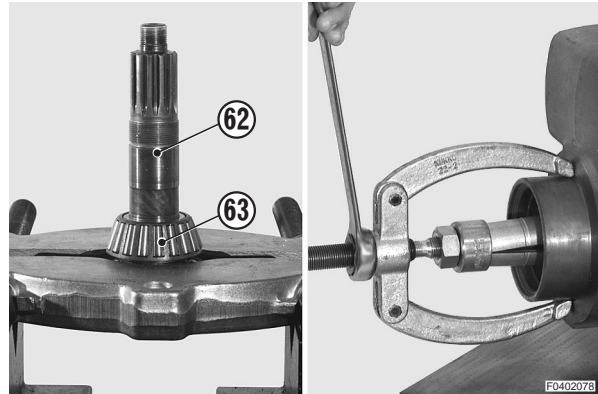

- 4 - Remove the snap ring (69) and the cover (70).

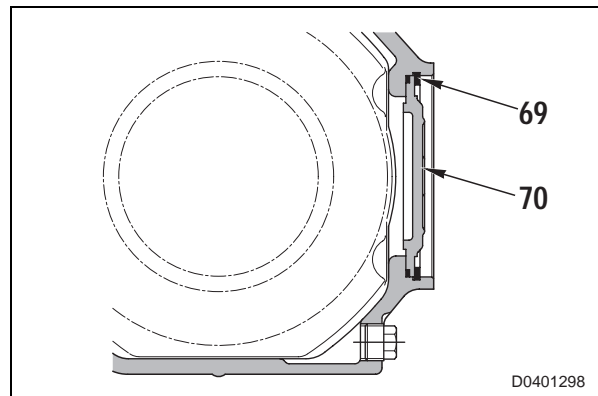

9. Steering cylinder

- 1 - Disconnect the tie-rods of the steering mechanism (16) from the joints (see «2. Joint») and from the piston rods of the steering cylinder (76).
Remove the four screws (77).

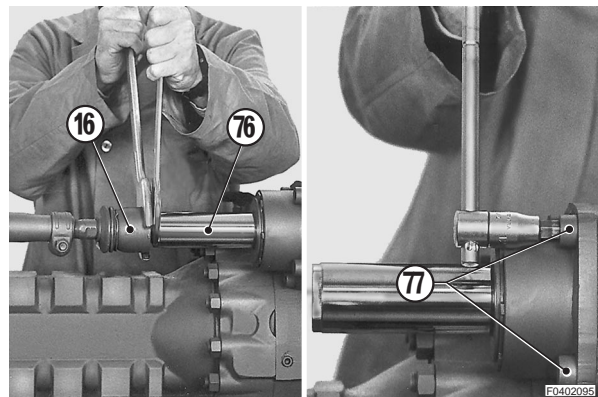

- 2 - Extract the complete cylinder (76) from the axle body.

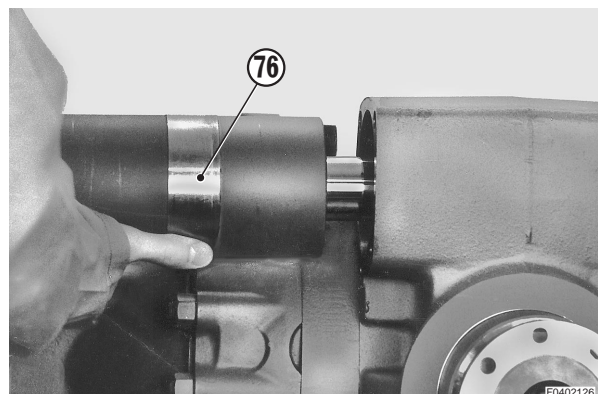

7. Final drive

1 - Using a press, assemble the thrust washers and inner bearing (10) into the hub (9).

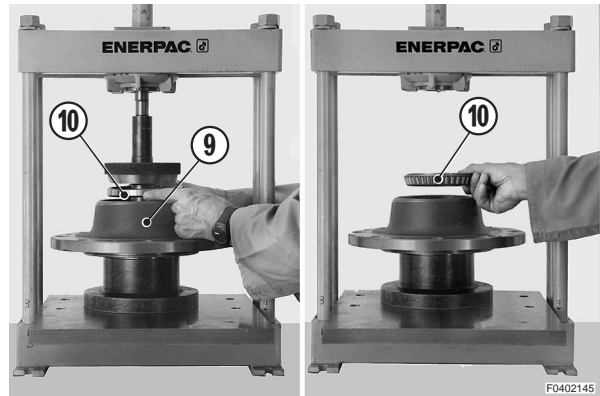

2 - Using a press and tool M12, assemble seal (11) into the hub (9).



3 - Using tool M13, assemble the seal (12) and ring (13) into the axle housing (15).
Seat the hub (9) on the axle housing (15).

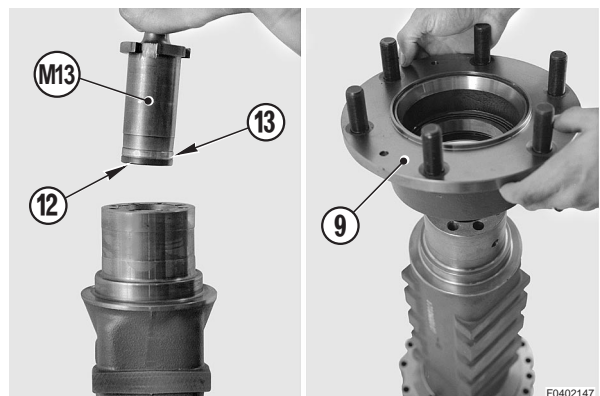

4 - Using tool M14 and a soft hammer, beat on outer bearing (92).

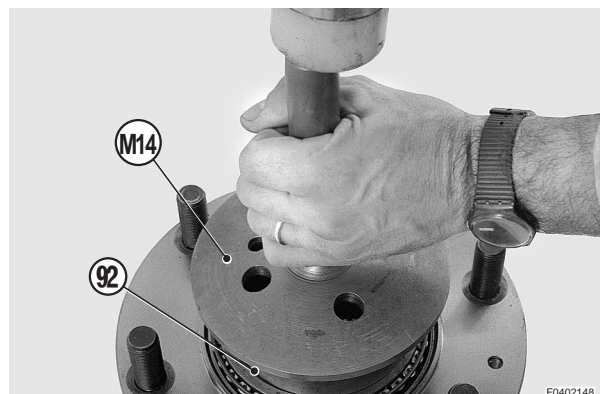

REMOVAL OF BOOM CYLINDER (For 1-piece boom)

! Extend the arm fully and open the bucket completely. Lower the work equipment until it is resting on the ground

- 1 - Put a sling around the cylinder (1).
 - 2 - Switch off the engine, release pressure in the cylinder by moving the RH PPC valve lever several times.
 - 3 - Remove the screw (2) and draw out the pin (3). ※1 ※3
 - 4 - Start the engine to retract the piston (4). ※2
 - 5 - Lower the cylinder (1) until it rests on a stand «A».
 - ★ To hold the piston rod in its fully retracted position tie it with wire.
 - 6 - Switch off the engine and release any residual hydraulic pressures. (For details, see «20. TESTING AND ADJUSTMENTS»).
 - 7 - Disconnect the tubes (5-6) and plug them. Also plug the holes in the safety valve to avoid entry of impurities.
 - 8 - Remove the screw (7) and take out the valve (8).
 - 9 - Remove the screw (9) and draw out the pin.
- 10 - Lift out the cylinder (1).

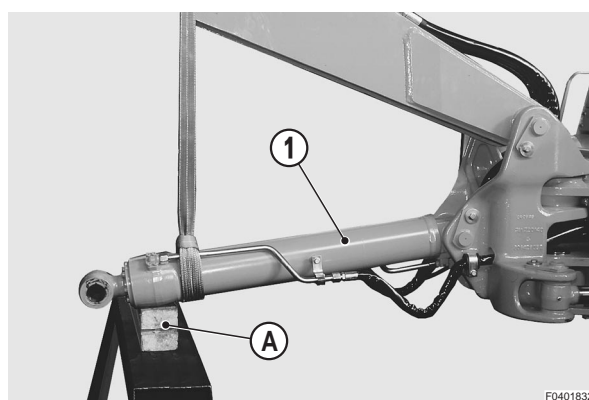
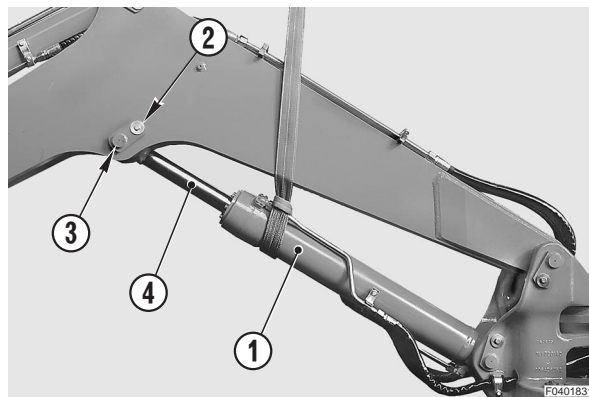

INSTALLATION OF BOOM CYLINDER (For 1-piece boom)

- To install, reverse the removal procedure.

※1

- ★ Insert the adjustments to a given clearance (distributed on both sides of the cylinder rod) until a clearance of 1 – 2 mm is obtained.

※2

- !** When aligning the positions between hole and pin, let the engine run at minimum idling. Do not insert fingers into the hole to check the alignment.

※3

- Inside bushings : ASL800050

※4

- ★ Insert the adjustments to a given clearance (distributed on both sides of the piston rod) until a clearance of 0.5 – 1 mm is obtained.
- Start the engine and bleed air from the cylinder. (For details, see «20. TESTING AND ADJUSTMENTS»).
- ★ After bleeding the air, check the oil level in the tank.

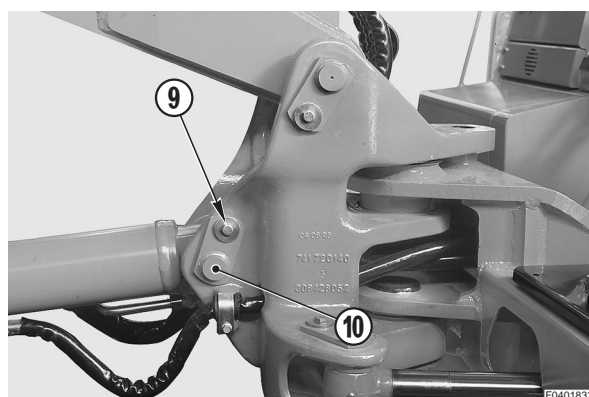
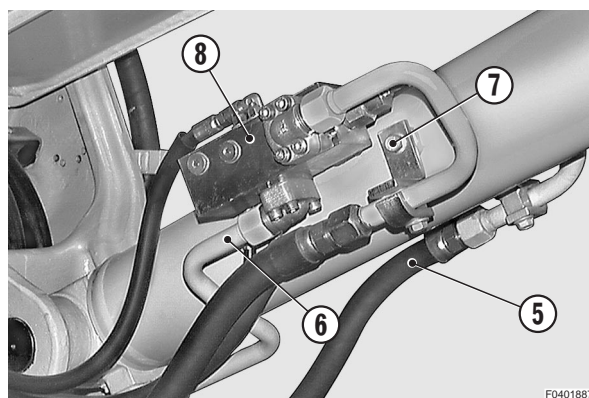

ASSEMBLY OF WORK EQUIPMENT CYLINDERS

- ★ Take care not to damage the seals or the sliding surfaces.
- ★ Prepare each individual component before final assembly.

1. Assembly of the head-retaining flange.

1 - Mount the scraper (1) in the external seating of the flange (2), making sure that it is positioned correctly. Drive home the scraper using the press.

2 - Mount the O-ring seal (3).

- ★ Use grease to hold the washer in place.

🔧 Sealant: ASL800050

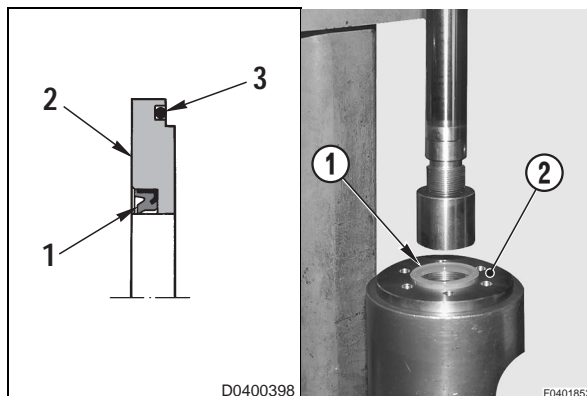

2. Head assembly

1 - Mount the internal central retaining ring, positioning first the O-ring (1) and then the sealing ring (2).

- ★ Make sure that the lowering of the retaining ring is turned towards the inside of the cylinder.

2 - Use the tool F1, mount the lip seal (3).

- ★ Check that the lips are facing towards the inside of the cylinder.

3 - Mount the guide rings (4).

4 - Mount the O-rings (5) and relative anti-extrusion rings (6) on the outside of the head (7).

- ★ Check the position of the anti-extrusion rings (6).

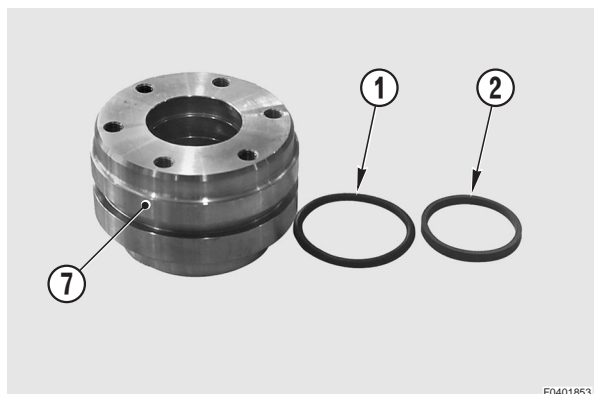
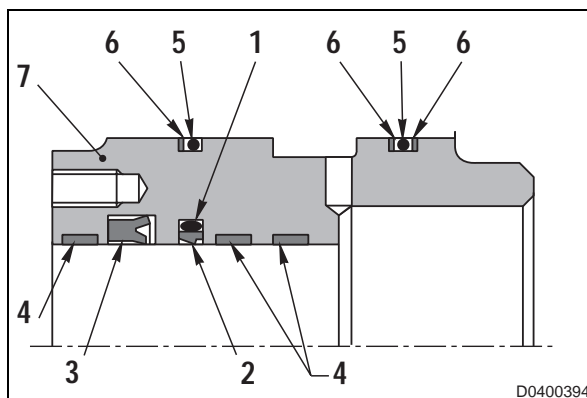
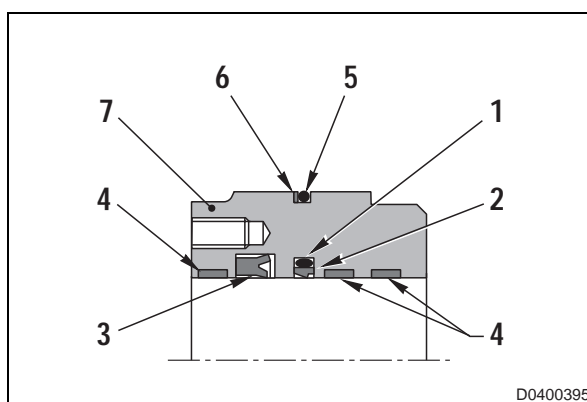

INSTALLATION OF ARM

- To install, reverse the removal procedure.

※1

 Inside bushings: ASL800050

- ★ Insert shim

※2

 When aligning the positions between holes and pin, do not insert fingers into the hole to check the alignment.

※3

- ★ Insert the adjustments to a given clearance (distributed on both sides of the piston) until a clearance of 1 – 2 mm is obtained.

 When aligning the positions between holes and pin, let the engine run at minimum idling. Do not insert fingers into the holes to check the alignment.

※4

 Inside bushings: ASL800050

- ★ Insert the adjustments to a given clearance (distributed on both sides) until a clearance of 0.5 – 1 mm is obtained.

 When aligning the positions between hole and pin, do not insert fingers into the holes to check the alignment.

40 MAINTENANCE STANDARD

P.T.O.	2	Swing motor	37
Front axle	3	Swivel joint.....	38
Transmission (2WS)	8	Travel motor	39
Rear axle (2WS).....	10	Travel motor brake valves	41
Transmission (4WS)	14	Servocontrol feed unit	42
Rear axle (4WS).....	16	Travel PPC valve.....	43
Differential	16	PPC valves.....	44
Brakes.....	17	PPC valve	
Parking brake cylinder.....	18	(blade, boom swing, 2-piece boom)	46
Final drive	19	Blade safety valve.....	47
Steering cylinder	20	Cylinders	48
Steering convergency angle	21	Work equipment	
Swing circle.....	22	(1-piece boom).....	50
Swing machinery.....	23	Work equipment	
Hydraulic pump	24	(2-piece boom).....	52
Control valve	26		

Brakes

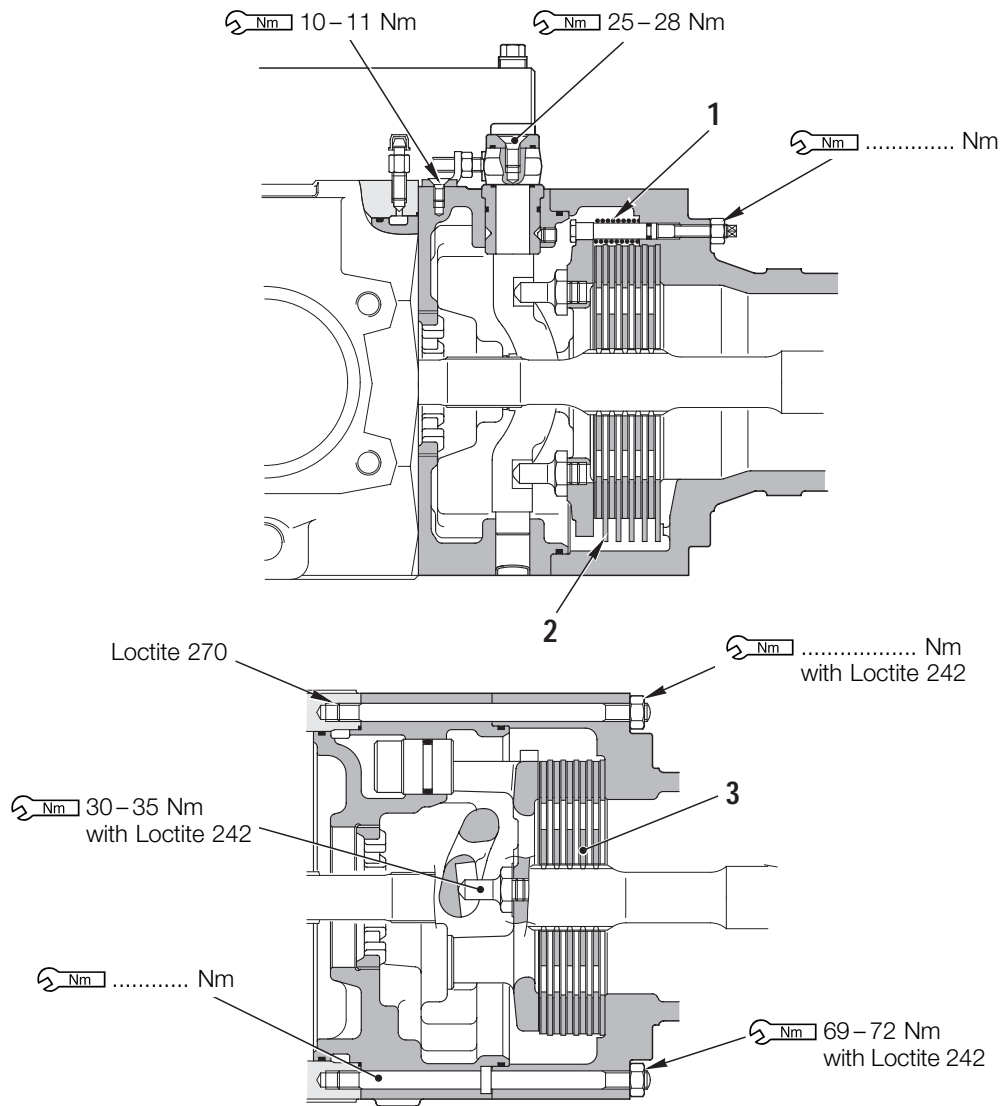

D0401172

Unit: mm

No.	Check item	Criteria					Remedy
		Standard size			Repair limit		
1	Returning spring	Free length x O.D.	Installed length	Installed load	Free length	Installed load	Replace if damage or deformed
		-	-	-	-	-	
		Standard thickness		Min. thickness		Replace	
-		4.5					
3	Disk clearance	Standard clearance			Max. clearance		Adjust
		0.75			-		

Steering and convergency angle

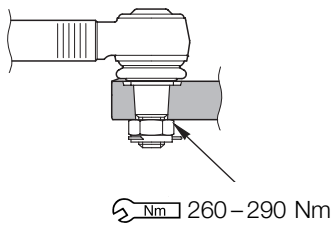
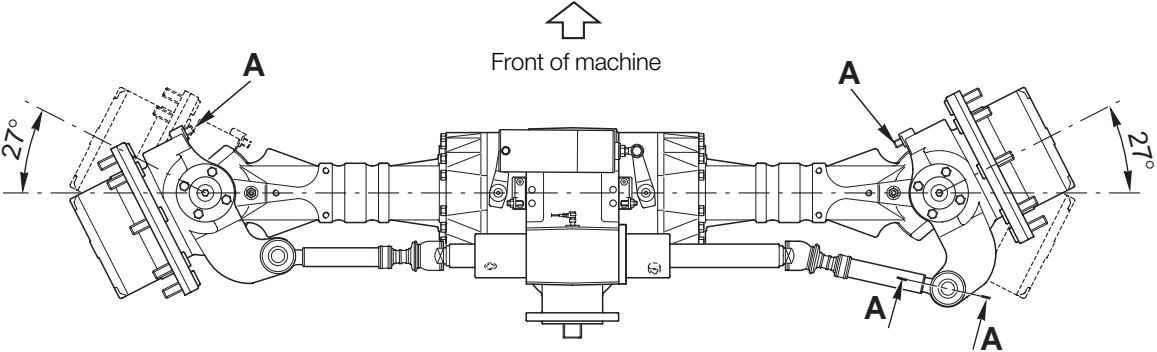

Section A - A

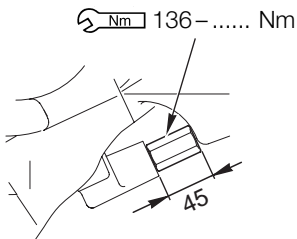

Detail A

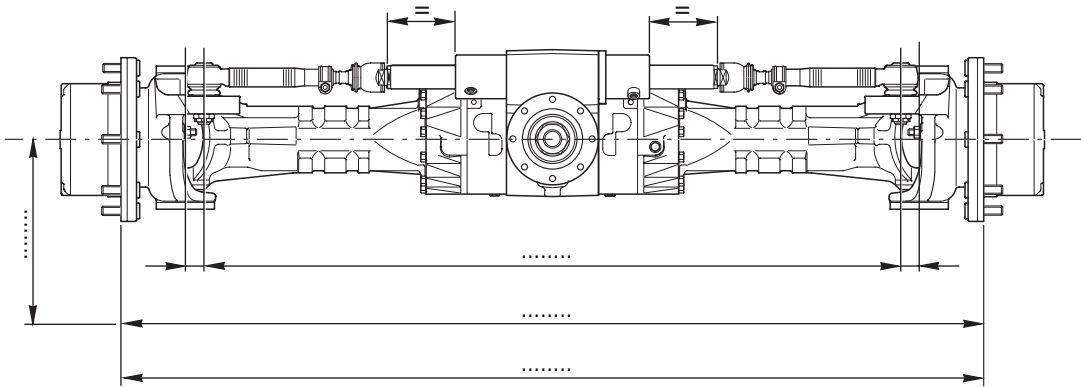

D0401295

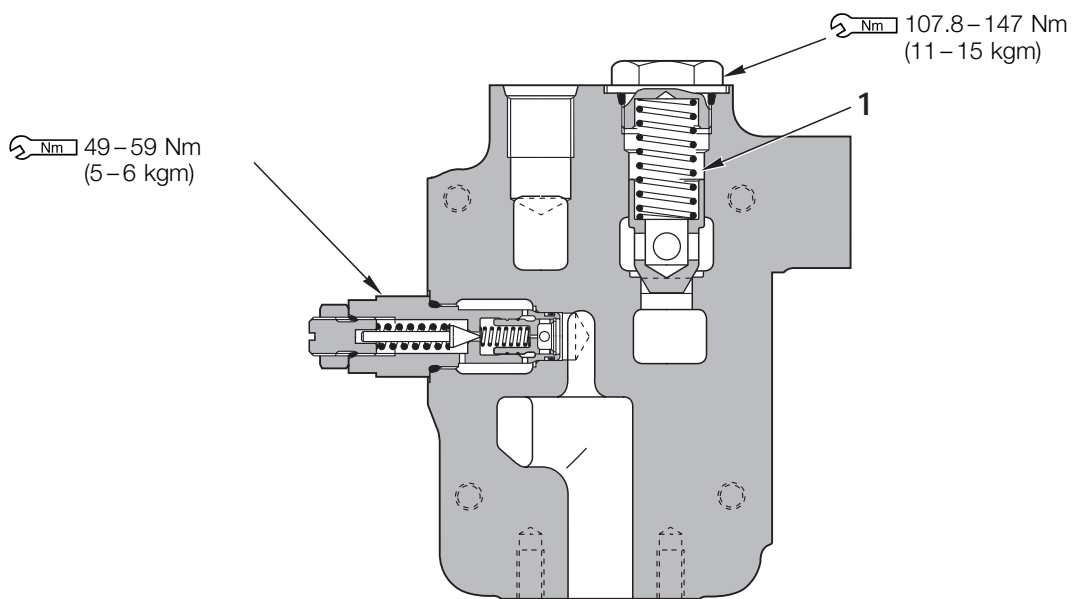

Section BB - BB

D0401059

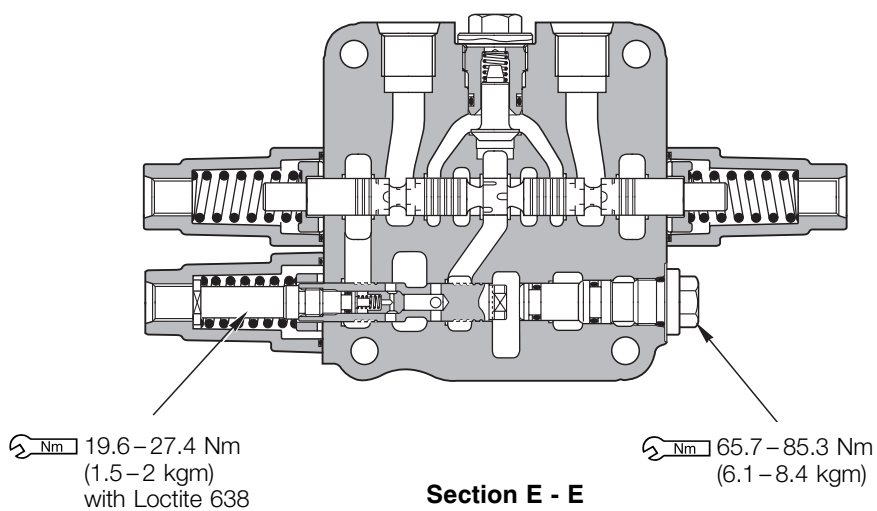

D0401061

Unit: mm

No.	Check item	Criteria					Remedy
		Free length x O.D.	Installed length	Installed load	Free length	Installed load	
1	Lift check valve spring	-	44.9	36.3 N 3.7 kg	-	-	Replace

TRAVEL MOTOR BRAKE VALVES

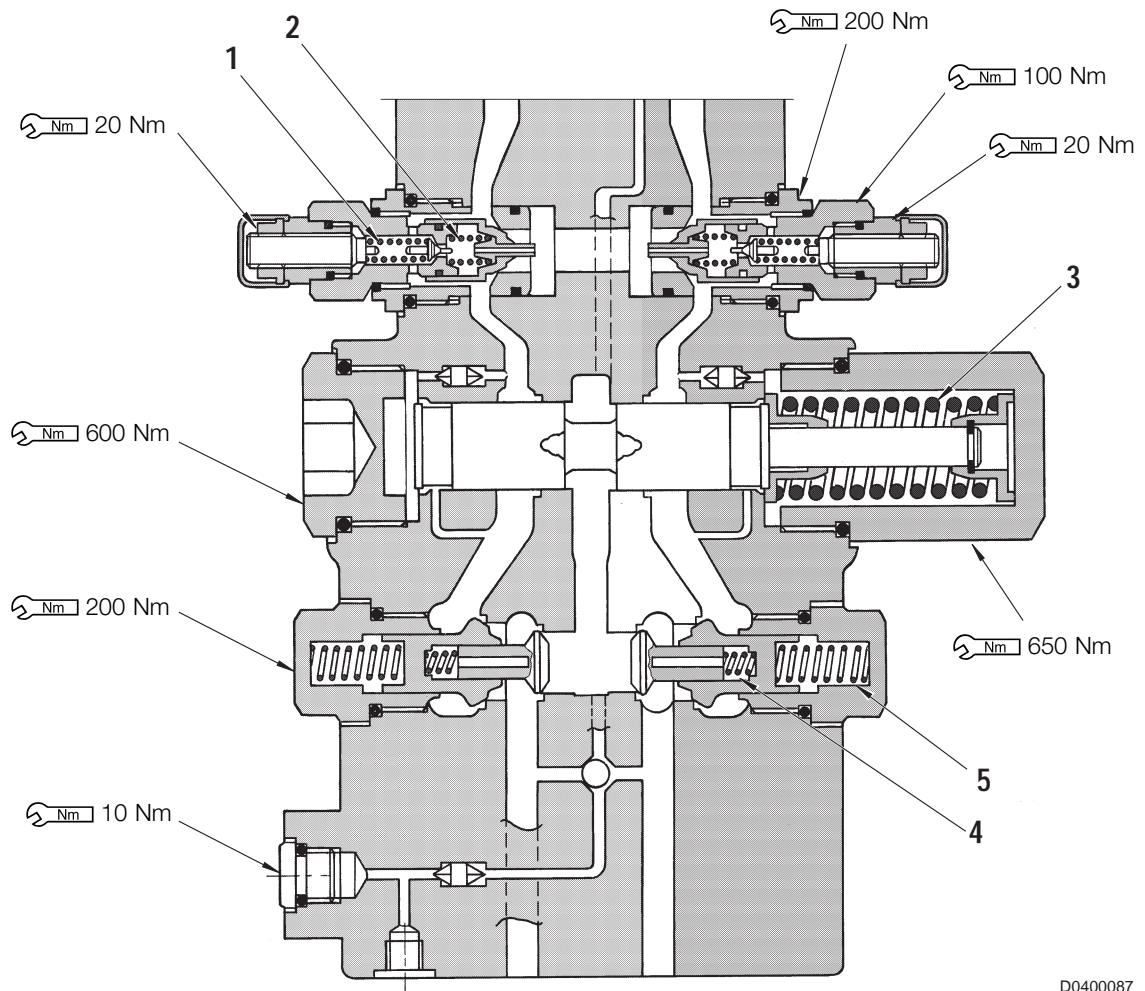

D0400087

Unit: mm

No.	Check item	Criteria					Remedy
		Standard size			Repair limit		
		Free length x O.D.	Installed length	Installed load	Free length	Installed load	
1	Pilot valve spring	-	-	-	-	-	Replace
2	Main valve spring	-	-	-	-	-	Replace
3	Piston return spring	-	-	-	-	-	Replace
4	Single-acting valve spring	-	-	-	-	-	Replace
5	Check valve spring	-	-	-	-	-	Replace

CLICK HERE TO **DOWNLOAD** THE COMPLETE MANUAL

- Thank you very much for reading the preview of the manual.
- You can download the complete manual from: www.heydownloads.com by clicking the link below



- Please note: If there is no response to CLICKING the link, please download this PDF first and then click on it.

CLICK HERE TO **DOWNLOAD** THE COMPLETE MANUAL