

# SHOP MANUAL

## **KOMATSU**

# **PC75UU-1**

MACHINE MODEL    SERIAL No.

**PC75UU-1            2908 and up**

- This shop manual may contain attachments and optional equipment that are not available in your area. Please consult your local Komatsu distributor for those items you may require. Materials and specifications are subject to change without notice.
- PC75UU-1 mount the 4D95L-1 engine;  
For details of the engine, see the 95 Series Engine Shop Manual

CLICK HERE TO **DOWNLOAD** THE COMPLETE MANUAL

- Thank you very much for reading the preview of the manual.
- You can download the complete manual from: [www.heydownloads.com](http://www.heydownloads.com) by clicking the link below



- Please note: If there is no response to CLICKING the link, please download this PDF first and then click on it.

CLICK HERE TO **DOWNLOAD** THE COMPLETE MANUAL

# WEIGHT TABLE



This weight table is a guide for use when transporting or handling components.

Unit: kg

Machine model	PC75UU-1
Serial No.	2908 and up
Engine assembly	400
• Engine (including mount)	290
• PTO	19
• Hydraulic pump	91
Radiator • oil cooler assembly	36
Fuel tank • hydraulic tank assembly (excluding fuel, oil)	110
Canopy	90
Operator's cab	138
Revolving frame	850
Counterweight	940
Swing machinery	63
Swing circle	112
Track frame assembly	1,300
• Track frame	836
• Idler	52.5 x 2
• Recoil spring assembly	45.0 x 2
• Track roller	14 x 10
• Carrier roller	15.5 x 2
• Sprocket	26 x 2
Track shoe assembly	
• Triple-grouser shoe (450 mm)	420 x 2

Machine model	PC75UU-1
Serial No.	2908 and up
5-spool control valve	23
4-spool control valve	23
1-spool control valve	5
Swing motor assembly	34
Center swivel joint	27
Trave motor assembly	77 x 2
Boom assembly	
• First boom	336
• Second boom	192
• Third boom	177
Arm assembly	215
Bucket assembly	276
Boom cylinder assembly	126
Arm cylinder assembly	82
Bucket cylinder assembly	55
Offset cylinder assembly	76
Blade assembly	297
Blade cylinder assembly	38

012W01

# HYDRAULIC PIPING

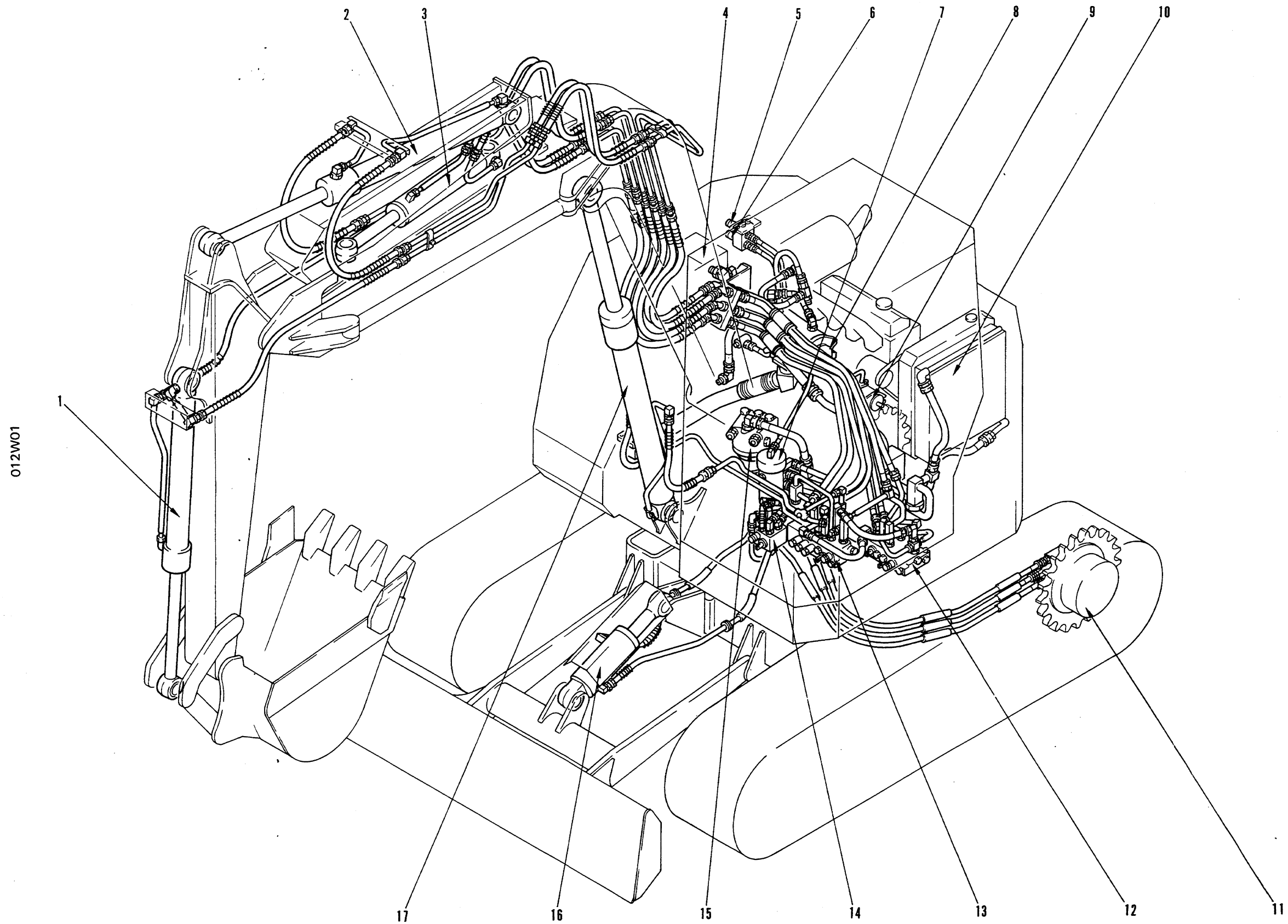

- 1. Bucket cylinder
- 2. Arm cylinder
- 3. Offset cylinder
- 4. Hydraulic tank
- 5. Swing brake solenoid valve
- 6. Straight-travel solenoid valve
- 7. Center swivel joint
- 8. Main pump and charging pump
- 9. Blade pump
- 10. Oil cooler
- 11. Travel motor
- 12. 4-spool control valve
- 13. 5-spool control valve
- 14. 1-spool control valve
- 15. Swing motor
- 16. Blade cylinder
- 17. Boom cylinder

# BLADE PUMP

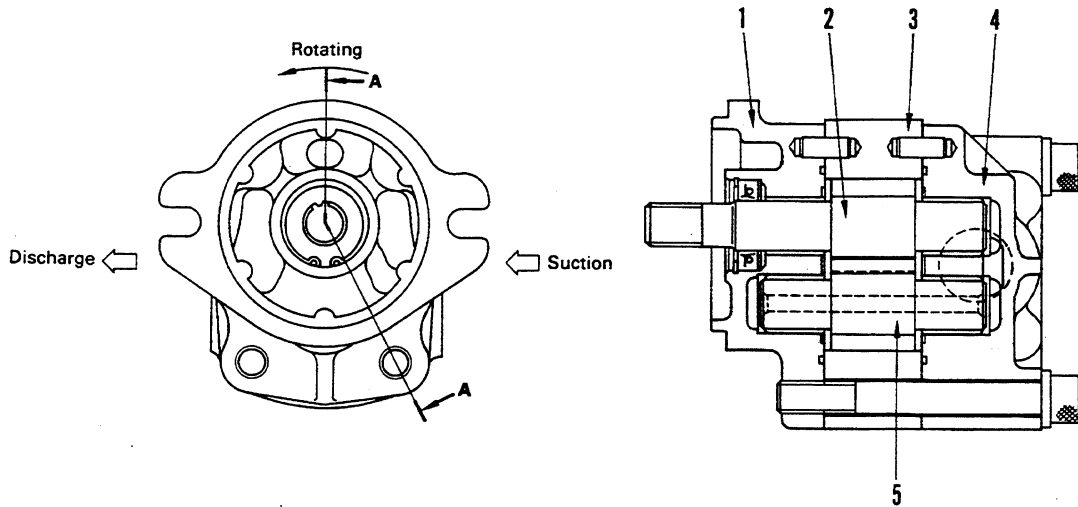

012W01

201F06417

1. Bracket
2. Drive gear
3. Housing
4. Cover
5. Driven gear

## SPECIFICATIONS

Type: SBL21

Theoretical delivery: 21.0 cc/rev

Set pressure: 210 kg/cm<sup>2</sup>

# CENTER SWIVEL JOINT

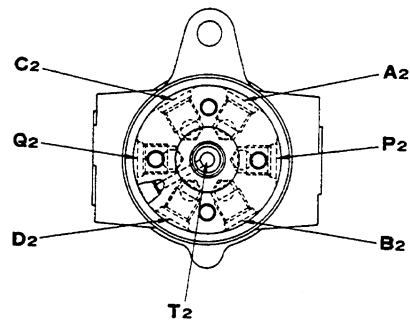
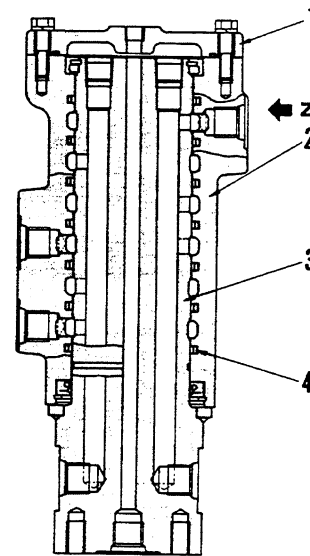
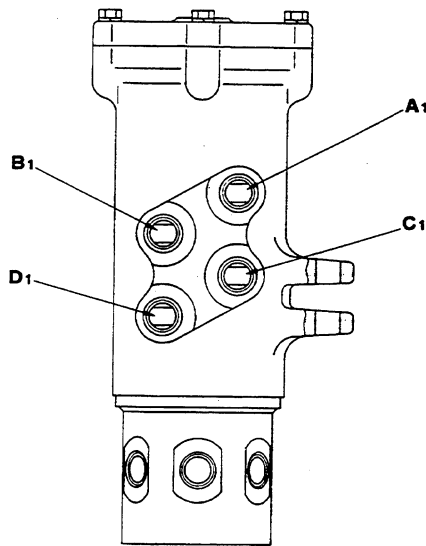
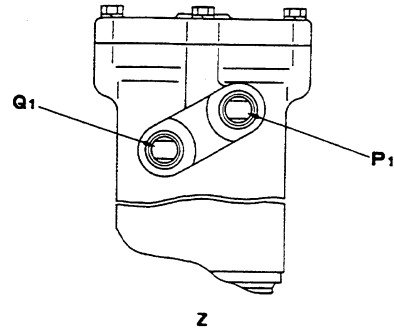
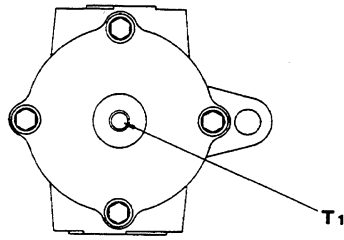

012W01

20UF01117

A1, A2: Between L.H. travel control valve and L.H. travel motor  
 B1, B2: Between L.H. travel control valve and L.H. travel motor  
 C1, C2: Between R.H. travel control valve and R.H. travel motor  
 D1, D2: Between R.H. travel control valve and R.H. travel motor  
 P1, P2: Between blade control valve and blade cylinder  
 Q1, Q2: Between blade control valve and blade cylinder  
 T1, T2: Between tank and both side travel motors

1. Cover
2. Shaft
3. Rotor
4. Slipper seal





---

# 20 TESTING AND ADJUSTING

---

012W01

Table of judgement standard value .....	20- 2
Tools for testing, adjusting, and troubleshooting .....	20-12
Adjusting valve clearance .....	20-13
Measuring compression pressure .....	20-14
Testing and adjusting fuel injection timing ...	20-15
Adjusting fuel control lever .....	20-16
Testing and adjusting hydraulic pressure in work equipment, swing, travel circuit ...	20-17
Testing and adjusting charging pump pressure .....	20-19
Measuring piston pump discharge amount	20-20
Bleeding air .....	20-21
Checking oil leakage from swivel joint .....	20-22
Troubleshooting .....	20-23

-  Before performing inspection, adjustment or troubleshooting, park the machine on level ground and check the safety pin and chock.
-  When performing joint work, make appropriate signals and allow only authorized personnel near the machine
-  When checking the water level, allow the engine to cool down before removing the radiator cap to prevent the risk of being scalded by hot water which may spurt out if the engine is hot.
-  Take great care to avoid getting caught in rotating parts such as the fan, etc.

012W01

Machine model			PC75UU-1		
Classi- fica- tion	Item	Measurement conditions	Unit	Standard value	Permissible value

• Main piston pump (HPV35 + 35)

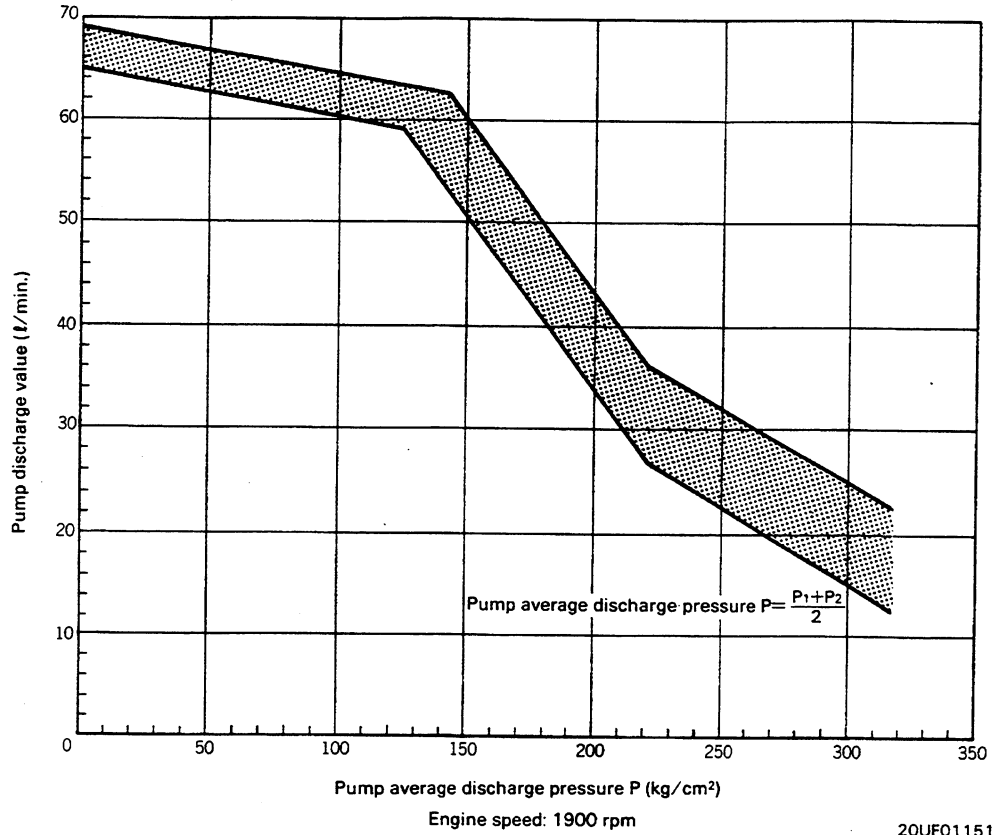

Check point	Delivery pressure of tester pump (kg/cm <sup>2</sup> )	Delivery pressure of other pump (kg/cm <sup>2</sup> )	Ave. pressure (kg/cm <sup>2</sup> )	Standard value for delivery Q (l/min.) Median ± 10	Permissible value Q (l/min.) Lower limit
(1)	P <sub>1</sub>	P <sub>2</sub>	$\frac{P_1 + P_2}{2}$	See graph	See graph
(2)	300	300	300	19 ± 5	14.0
(3)	250	250	250	26.5 ± 5	21.5
(4)	170	170	170	47 ± 4.5	42.5
(5)	80	80	80	63.5 ± 2	61.0

Note 1: If an oil pressure gauge (600 kg/cm<sup>2</sup>) is installed to the pump circuit on the side where the flow meter is not installed, the average value can be obtained accurately.

2: Measure with discharge pressures P<sub>1</sub> and P<sub>2</sub> as close as possible to the average.

# BLEEDING AIR

## 1. Bleeding air from hydraulic cylinders

★ When the hydraulic cylinders or hydraulic piping have been removed and installed again, bleed the air from the hydraulic cylinders as follows.

- 1) Start the engine and run at low idling for approx. 5 minutes.
- 2) Run the engine at low idling, then raise and lower the boom 4 — 5 times in succession.  
★ Operate the piston rod to approx. 100 mm before the end of its stroke. Do not relieve the circuit under any circumstances.
- 3) Run the engine at high idling and repeat Step 2). After that, run the engine at low idling, and operate the piston rod to the end of its stroke to relieve the circuit.
- 4) Repeat Steps 2) and 3) to bleed the air from the arm and bucket cylinders.

## 2. Bleeding air from main piston pump

★ After changing the oil in the hydraulic tank or replacing the main pump, or if the pump suction piping or charging pump have been removed, bleed the air as follows after completion of installation.

- 1) Disconnect drain hose (1).
- 2) Remove plug (2).
- 3) Add engine oil through the plug hole  
★ Add oil until oil flows out from the plug hole.
- 4) Connect hose (1), fit an O-ring, then install plug (2).



012W01

012W01

## 2. POINTS TO REMEMBER WHEN HANDLING HYDRAULIC EQUIPMENT

With the increase in pressure and precision of hydraulic equipment, the most common cause of failure is dirt (foreign material) in the hydraulic circuit. When adding hydraulic oil, or when disassembling or assembling hydraulic equipment, it is necessary to be particularly careful.

- 1) **Be careful of the operating environment.**  
Avoid adding hydraulic oil, replacing filters, or repairing the machine in rain or high winds, or places where there is a lot of dust.
- 2) **Disassembly and maintenance work in the field.**  
If disassembly or maintenance work is carried out on hydraulic equipment in the field, there is danger of dust entering the equipment. It is also difficult to confirm the performance after repairs, so it is desirable to use unit exchange. Disassembly and maintenance of hydraulic equipment should be carried out in a specially prepared dustproof workshop, and the performance should be confirmed with special test equipment.

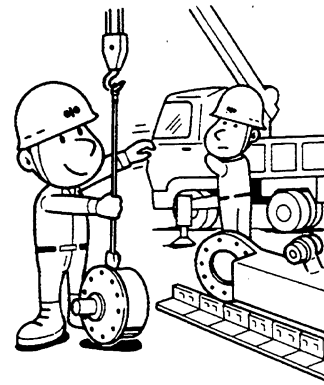

F20505217

- 3) **Sealing openings.**  
After any piping or equipment is removed, the openings should be sealed with caps, tapes, or vinyl bags to prevent any dirt or dust from entering. If the opening is left open or is blocked with a rag, there is danger of dirt entering or of the surrounding area being made dirty by leaking oil so never do this.  
Do not simply drain oil out on to the ground, collect it and ask the customer to dispose of it, or take it back with you for disposal.

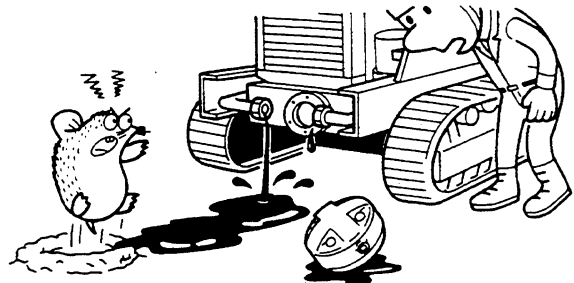

F20505218

- 4) **Do not let any dirt or dust get in during refilling operations.**  
Be careful not to let any dirt or dust get in when refilling with hydraulic oil. Always keep the oil filler and the area around it clean, and also use clean pumps and oil containers. If an oil cleaning device is used, it is possible to filter out the dirt that has collected during storage, so this is an even more effective method.

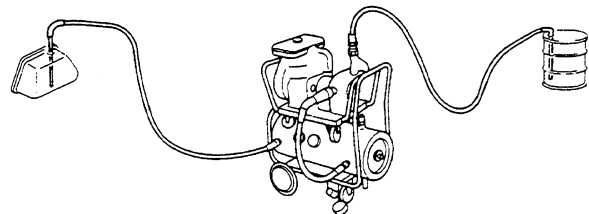

F20505219



CLICK HERE TO **DOWNLOAD** THE COMPLETE MANUAL

- Thank you very much for reading the preview of the manual.
- You can download the complete manual from: [www.heydownloads.com](http://www.heydownloads.com) by clicking the link below



- Please note: If there is no response to CLICKING the link, please download this PDF first and then click on it.

CLICK HERE TO **DOWNLOAD** THE COMPLETE MANUAL

Note: Check first if CN48 and CN45 (diode assemblies) are normal.

**CN45**  
Diode ass'y

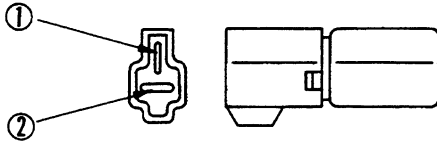

**CN48**  
Diode ass'y

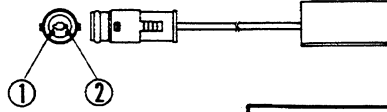

Table 1

Tester rod		Resistance value
Red	Black	
①	②	Infinity
②	①	Finite value

012W01

Cause	Remedy
Defective straight-travel solenoid	Replace
Defective contact, or disconnection in wiring harness between CN51 (2) and CN44 (1)	Clean or replace
Defective contact, or disconnection in wiring harness between CN50 (2) and CN51 (1)	Clean or replace
Defective travel limit switch	Replace
Defective contact, or disconnection in wiring harness between CN42 (1) and CN50 (1)	Clean or replace
Defective work equipment * swing limit switch	Replace
Defective contact, or disconnection in wiring harness between starting switch ACC and CN42 (1)	Clean or replace
Defective straight-travel solenoid	Replace

# H-4 In fine control area, work equipment, travel, swing suddenly start to move

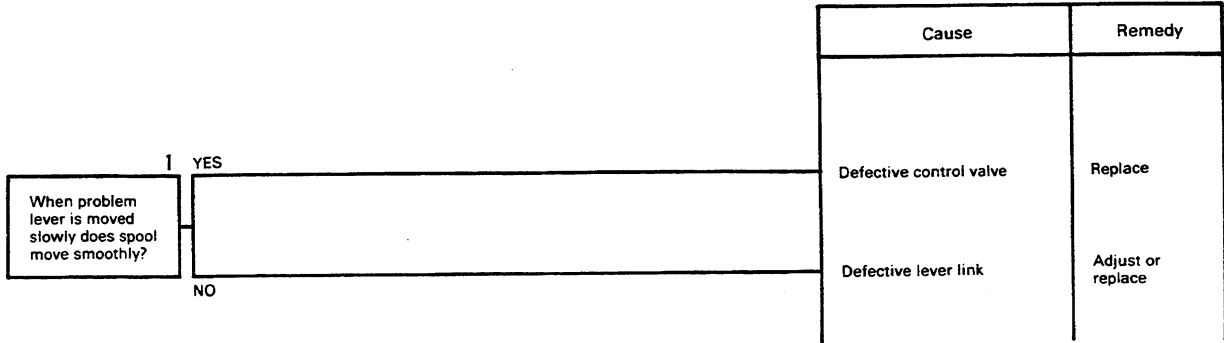

012W01



# PRECAUTIONS WHEN CARRYING OUT OPERATION

[When carrying out removal or installation (disassembly or assembly) of units, be sure to follow the general precautions given below when carrying out the operation.]

## 1. Precautions when carrying out removal work

- If the coolant contains antifreeze, dispose of it correctly.
- After disconnecting hoses or tubes, cover them or fit blind plugs to prevent dirt or dust from entering.
- When draining oil, prepare a container of adequate size to catch the oil.
- Confirm the match marks showing the installation position, and make match marks in the necessary places before removal to prevent any mistake when assembling.
- To prevent any excessive force from being applied to the wiring, always hold the connectors when disconnecting the connectors.
- Fit wires and hoses with tags to show their installation position to prevent any mistake when installing.
- Check the number and thickness of the shims, and keep in a safe place.
- When raising components, be sure to use lifting equipment of ample strength.
- When using forcing screws to remove any components, tighten the forcing screws alternately.
- Before removing any unit, clean the surrounding area and fit a cover to prevent any dust or dirt from entering after removal.

## ★ Precautions when handling piping during disassembling

Fit the following blind plugs into the piping after disconnecting it during disassembly operations.

### 1) Hoses and tubes using sleeve nuts

Nominal number	Plug (nut end)	Sleeve nut (elbow end) Use the two items below as a set
02	07376-50210	07221-20210 (Nut), 07222-00210 (Plug)
03	07376-50315	07221-20315 (Nut), 07222-00312 (Plug)
04	07376-50422	07221-20422 (Nut), 07222-00414 (Plug)
05	07376-50522	07221-20522 (Nut), 07222-00515 (Plug)
06	07376-50628	07221-20628 (Nut), 07222-00616 (Plug)
10	07376-51034	07221-21034 (Nut), 07222-01018 (Plug)
12	07376-51234	07221-21234 (Nut), 07222-01219 (Plug)

### 2) Split flange type hoses and tubes

Nominal number	Flange (hose end)	Sleeve head (tube end)	Split flange
04	07379-00400	07378-10400	07371-30400
05	07379-00500	07378-10500	07371-30500

### 3) If the part is not under hydraulic pressure, the following corks can be used.

Nominal number	Part number	Dimensions		
		D	d	L
06	07049-00608	6	5	8
08	07049-00811	8	6.5	11
10	07049-01012	10	8.5	12
12	07049-01215	12	10	15
14	07049-01418	14	11.5	18
16	07049-01620	16	13.5	20
18	07049-01822	18	15	22
20	07049-02025	20	17	25
22	07049-02228	22	18.5	28
24	07049-02430	24	20	30
27	07049-02734	27	22.5	34

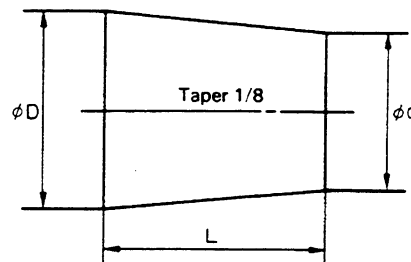

202F2001

012W01

## REMOVAL OF ENGINE ASSEMBLY

1. Remove counterweight assembly.

⚠ Disconnect the cable from the negative (-) terminal of the battery case.

2. Drain cooling water and hydraulic oil.

🚰 Hydraulic tank: 70 l

3. Disconnect radiator inlet hose (1) and radiator outlet hose (2).

4. Disconnect heater hose (3) and water temperature sensor wiring (4).

5. Remove fan (5).

6. Disconnect fuel control cable (6).

7. Disconnect fuel hoses (7) and (8).

8. Disconnect starting motor wiring (9).

9. Remove air intake hose (10) and muffler assembly (11).

10. Remove blade pump top piping flange (12) and blade pump bottom hose (13).

11. Remove main pump tube (14) and flange (15).

12. Disconnect 6 main pump hoses (16).

13. Remove engine assembly (17). ※ 1

★ When removing and installing the front right mounting bolt, loosen the alternator adjustment bolt, and move it toward the alternator divider board.

📦 Engine assembly: 398 kg

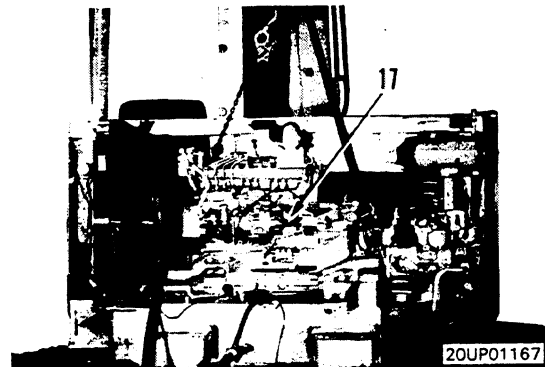
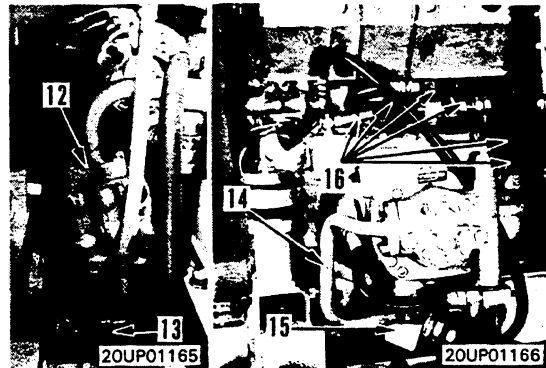
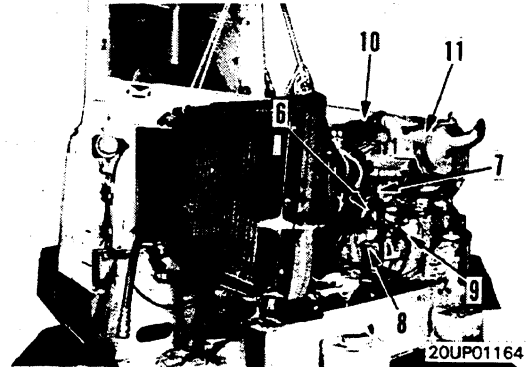
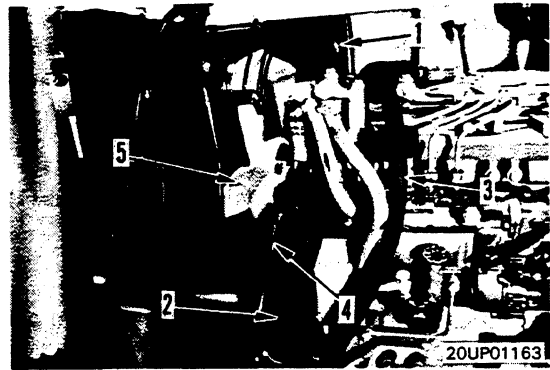

## INSTALLATION OF ENGINE ASSEMBLY

- Carry out installation in the reverse order to removal.

※ 1

🔧 Engine mount mounting bolt:  $28.5 \pm 3$  kg

- ★ Bleed the air from the fuel system.
- Refilling with oil
  - ★ Add oil to the specified level, and run the engine to circulate the oil through the system. Then check the oil level again.

🚰 Hydraulic tank: 70 l

- Refilling with water
  - ★ Add water to the specified level, and run the engine to circulate the water through the system. Then check the water level again.

012W01

10. Pins  
Remove 36 pins (48).

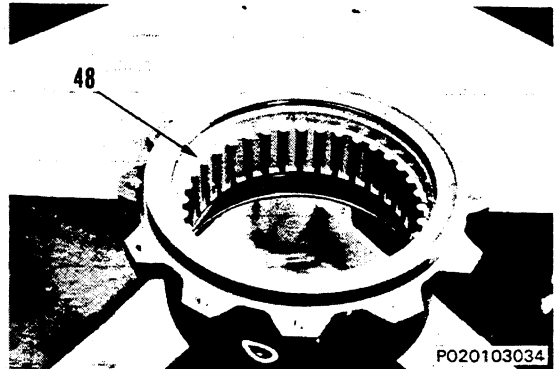

11. Distance piece  
Remove distance piece (49).

12. Bearing race  
Remove bearing race (50) by hitting them lightly on the rear side.

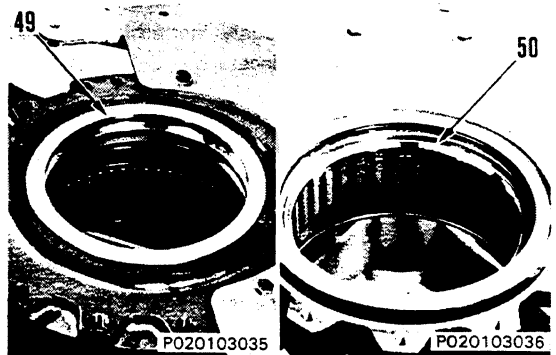

012W01

012W01

- 7) Turn the travel motor on its side by operating the repair stand and install cylinder block piston assembly (18) in reference to the shaft spline.



- 8) Install disc (17) and plate (16).

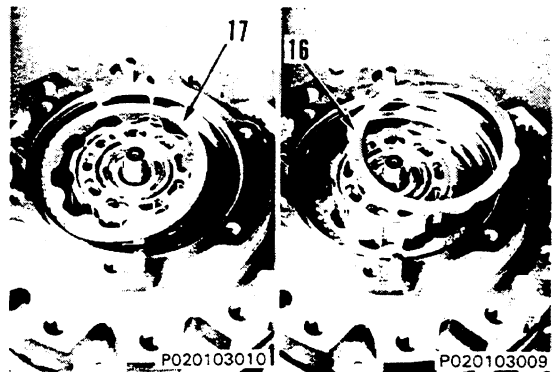

#### 10. Piston

- 1) Install O-ring (15) in the piston.

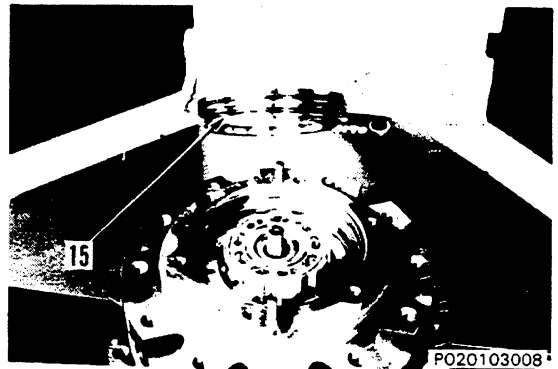

- 2) Install piston (14), using press-fitting kit (4).

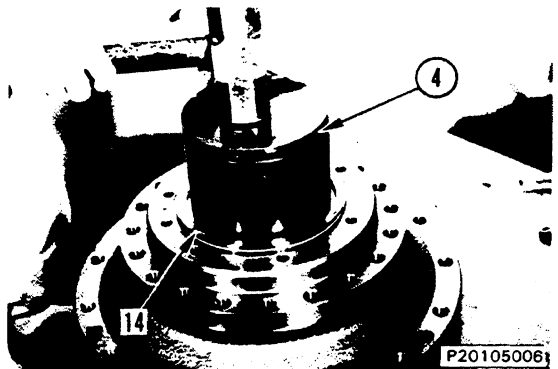

012W01

2) Install the following parts to the case.

- i) Press fit bearing (24) (O.D.: 150 mm) into case (8), then install snap ring (22).

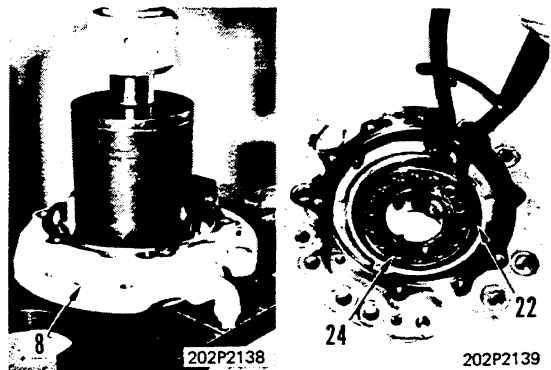

- ii) Install oil seal (32) (O.D.: 110 mm).

 Oil seal lip: Grease G2-L1

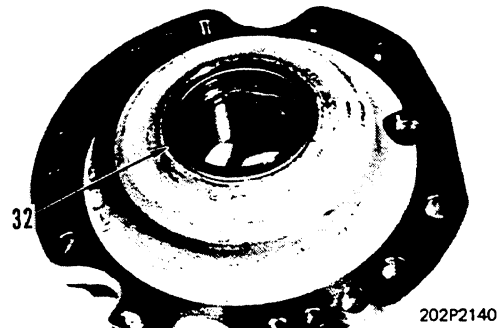

3) Assemble the carrier assembly as follows.

- i) Support the inner race of the bearing installed to case (8) with large pinion gear (17).
- ii) Set the spline of carrier assembly (21) in alignment with the pinion gear, then press fit into position.

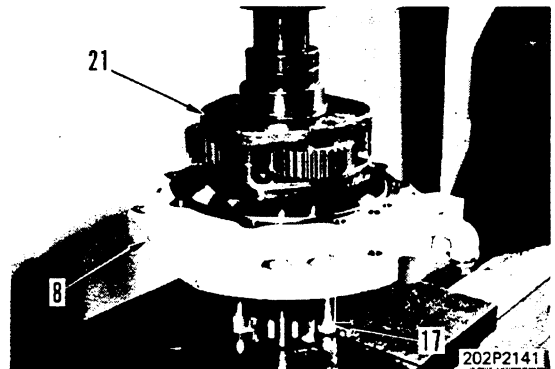

2. Large pinion gear

- 1) Install large pinion gear (17), an O-ring, and holder (16).
- 2) Tighten bolt (15).

 Bolt:  $28.2 \pm 3.2$  kgm

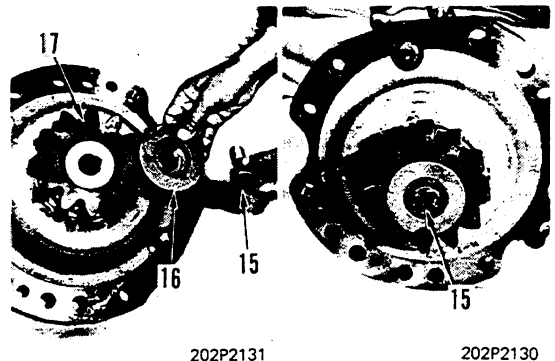

012W01

- 3) Fit tool **C4** to piston ring; then using clamp ③, compress piston ring.
- 4) Assemble wear ring (9).

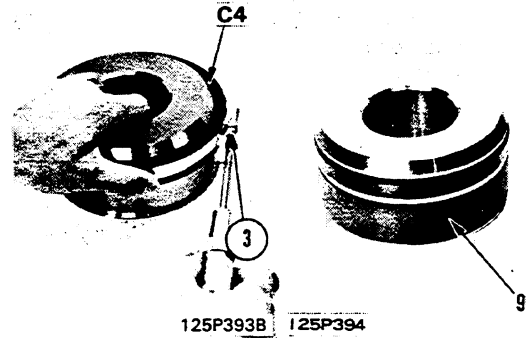

3. Set piston rod (8) to tool **C2**.
4. Assemble cylinder head assembly (7) and piston assembly (6) to rod, and fit nut (5).

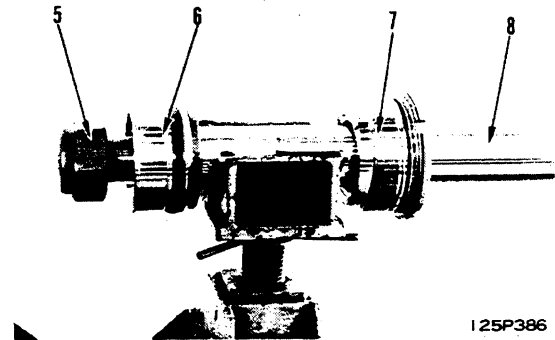

5. Set to tool **D2**, and tighten nut (5).

 Piston nut:

Unit: kgm

Boom	Arm	Bucket	Offset	Blade
170 ± 17	170 ± 17	145 ± 14.5	145 ± 14.5	265 ± 26.5

6. Remove piston rod and head assembly from tool **C2**.
7. Set cylinder (4) to tool **C1**.
8. Raise piston rod assembly (3) and assemble in cylinder (4).

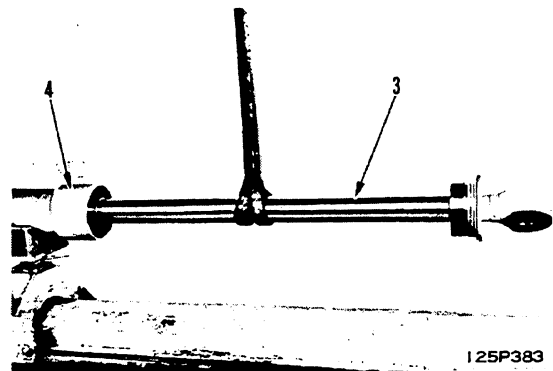
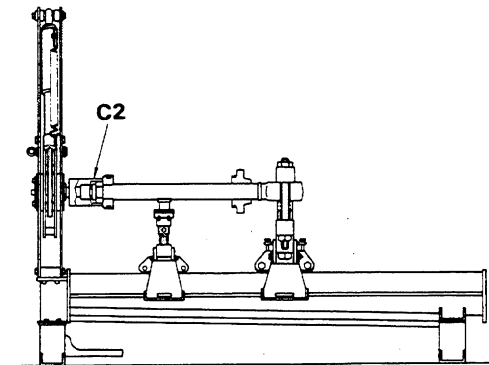

# TRACK FRAME

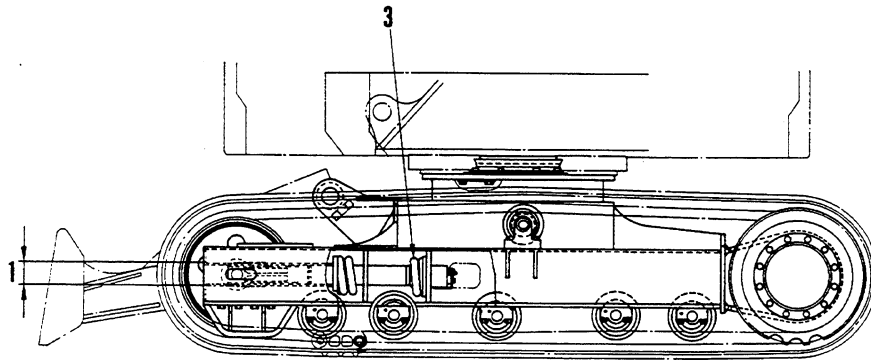
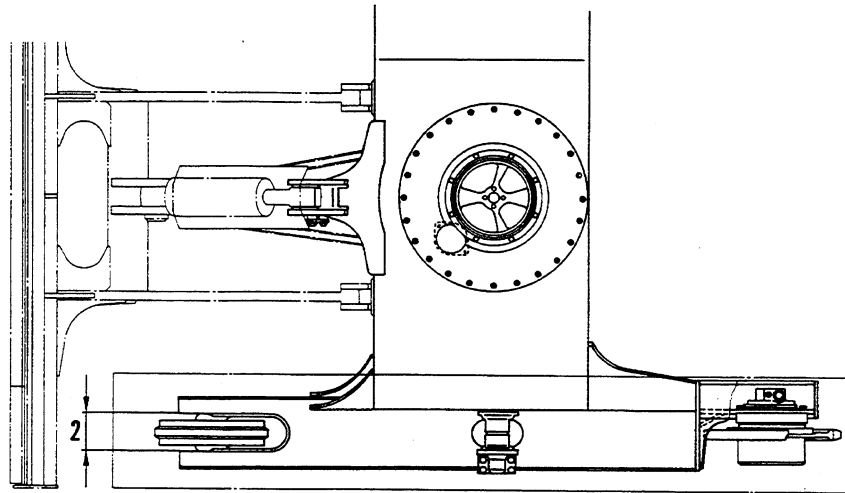

012W01

20UF01258

Unit: mm

No.	Check item	Criteria				Remedy		
			Standard size	Repair limit				
1	Vertical width of idler guide	Track frame	74	78		Rebuild		
		Idler support	73	69		Rebuild or replace		
2	Horizontal width of idler guide	Track frame	158	162		Rebuild		
		Idler support	156	152		Rebuild or replace		
3	Recoil spring	Standard size			Repair limit		Replace	
			Free length	Installed length	Installed lod	Free length		Installed load
		Steel shoe	402	327	4,665 kg	393		3,960 kg
	Rubber shoe	402	287	7,153 kg	393	6,440 kg		

012W01

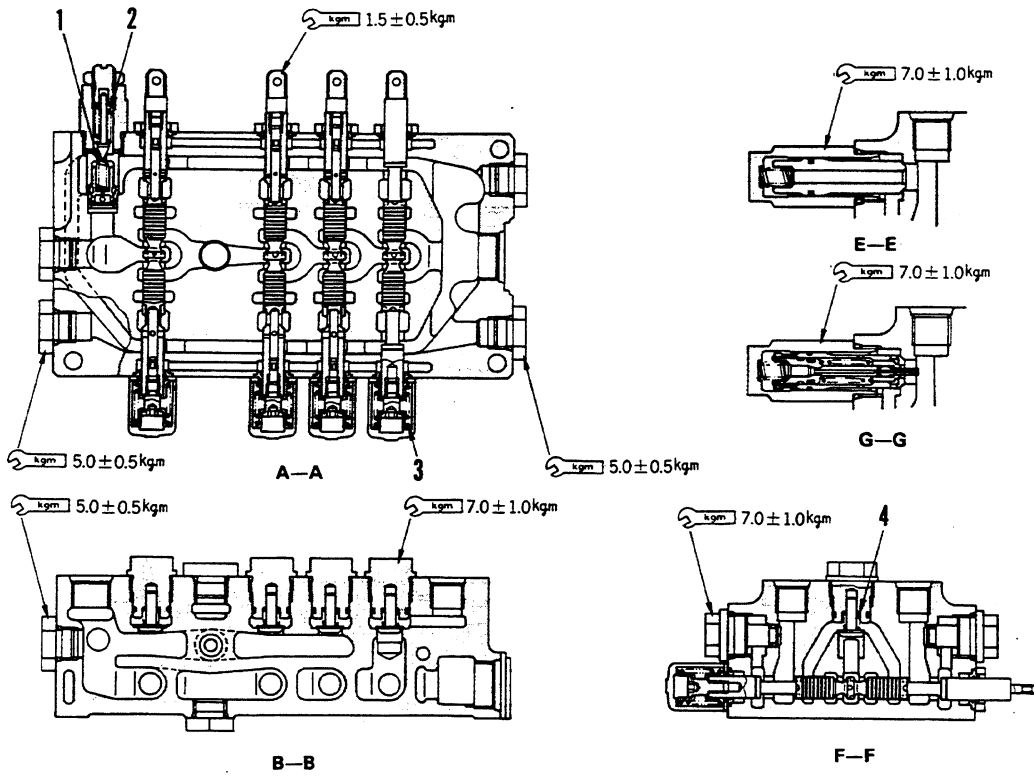

20UF01131

Unit: mm

No.	Check item	Criteria				Remedy
		Standard size		Repair limit		
		Free length	Installed length	Installed load	Free length	Installed load
1	Main relief valve pilot poppet spring	30.65	26.3	37.7 kg	—	30.2 kg
2	Main relief valve main valve spring	23.17	19.0	4.2 kg	—	3.4 kg
3	Spool return spring	55.7	26.5	10.0 kg	—	8.0 kg
4	Check valve spring	16.4	11.5	1.4 kg	—	1.1 kg

Replace spring if any damages or deformations are found

CLICK HERE TO **DOWNLOAD** THE COMPLETE MANUAL

- Thank you very much for reading the preview of the manual.
- You can download the complete manual from: [www.heydownloads.com](http://www.heydownloads.com) by clicking the link below



- Please note: If there is no response to CLICKING the link, please download this PDF first and then click on it.

CLICK HERE TO **DOWNLOAD** THE COMPLETE MANUAL