

Shop Manual

PC60-7

HYDRAULIC EXCAVATOR

SERIAL NUMBERS **PC60-7 - 45001 thru 52373**

This material is proprietary to Komatsu America International Company and is not to be reproduced, used, or disclosed except in accordance with written authorization from Komatsu America International Company.

It is our policy to improve our products whenever it is possible and practical to do so. We reserve the right to make changes or add improvements at any time without incurring any obligation to install such changes on products sold previously.

Due to this continuous program of research and development, periodic revisions may be made to this publication. It is recommended that customers contact their distributor for information on the latest revision.

CLICK HERE TO **DOWNLOAD** THE COMPLETE MANUAL

- Thank you very much for reading the preview of the manual.
- You can download the complete manual from: www.heydownloads.com by clicking the link below



- Please note: If there is no response to CLICKING the link, please download this PDF first and then click on it.

CLICK HERE TO **DOWNLOAD** THE COMPLETE MANUAL

COATING MATERIALS

The recommended coating materials prescribed in Komatsu Shop Manuals are listed below.

Category	Komatsu code	Part No.	Q'ty	Container	Main applications, features
Adhesive	LT-1A	790-129-9030	150 g	Tube	<ul style="list-style-type: none"> Used to prevent rubber gaskets, rubber cushions, and cork plugs from coming out
	LT-1B	790-129-9050	20 g (x2)	Plastic container	<ul style="list-style-type: none"> Used in places requiring an immediately effective, strong adhesive. Used for plastics (except polyethylene, polypropylene, tetrafluoroethylene, and vinyl chloride), rubber, metal, and non-metal.
	LT-2	09940-00030	50 g	Plastic container	<ul style="list-style-type: none"> Features: Resistance to heat, chemicals Used for anti-loosening and sealant purposes for bolts and plugs.
	LT-3	790-129-9060 (Set of adhesive and hardening agent)	Adhesive :1 Kg Hardening agent: :500 g	Can	<ul style="list-style-type: none"> Used as adhesive or sealant for metal, glass, plastic
	LT-4	790-129-9040	250 g	Plastic container	<ul style="list-style-type: none"> Used as sealant for machined holes
	(Loctite 648-50)	79A-129-9110	50 cc	—	<ul style="list-style-type: none"> Features: Resistance to heat, chemicals Used at joint portions subject to high temperature
Gasket sealant	LG-1	790-129-9010	200 g	Tube	<ul style="list-style-type: none"> Used as adhesive or sealant for gaskets and packings of power train case, etc.
	LG-3	790-129-9070	1 Kg	Can	<ul style="list-style-type: none"> Features: Resistance to heat Used as sealant for flange surfaces and bolts at high temperature locations, used to prevent seizure Used as sealant for heat resistant gasket for high temperature locations such as engine precombustion chamber, exhaust pipe
	LG-4	790-129-9020	200 g	Tube	<ul style="list-style-type: none"> Features: Resistance to water, oil Used as sealant for flange surface, thread Also possible to use as sealant for flanges with large clearance Used as sealant for mating surfaces of final drive case, transmission case
	LG-5	790-129-9080	1 Kg	Plastic container	<ul style="list-style-type: none"> Used as sealant for various threads, pipe joints, flanges Used as sealant for tapered plugs, elbows, nipples of hydraulic piping
	LG-6	09940-00011	250 g	Tube	<ul style="list-style-type: none"> Features: Silicon based, resistance to heat, cold Used as sealant for flange surface, thread Used as sealant for oil pan, final drive case, etc.
	LG-7	09920-00150	150 g	Tube	<ul style="list-style-type: none"> Features: Silicon based, quick hardening type Used as sealant for flywheel housing, intake manifold, oil pan, thermostat housing, etc.
Rust prevention lubricant	LM-G	09940-00051	60 g	Can	<ul style="list-style-type: none"> Used as lubricant for sliding parts (to prevent squeaking)
Molybdenum disulphide lubricant	LM-P	09940-00040	200 g	Tube	<ul style="list-style-type: none"> Used to prevent seizure or scuffing of the thread when press fitting or shrink fitting Used as lubricant for linkage, bearings, etc.
Lithium grease	G2-LI	SYG-350LI SYG-400LI SYG-400LI-A SYG-160LI SYGA-160CNLI	Various	Various	<ul style="list-style-type: none"> General purpose type
Calcium grease	G2-CA	SSG2-400CA SYG2-350CA SYG2-400CA-A SYG2-160CA SYGA-16CNCA	Various	Various	<ul style="list-style-type: none"> Used for normal temperature, light load bearing at places in contact with water or steam
Molybdenum disulphide grease	—	SYG2-400M	400 g (10 per case)	Bellows type	<ul style="list-style-type: none"> Used for places with heavy load

01 GENERAL

General assembly drawing	01-2
Specifications	01-3
Weight table	01-5
List of lubricant and water	01-7

020107

PTO (COUPLING)

020107

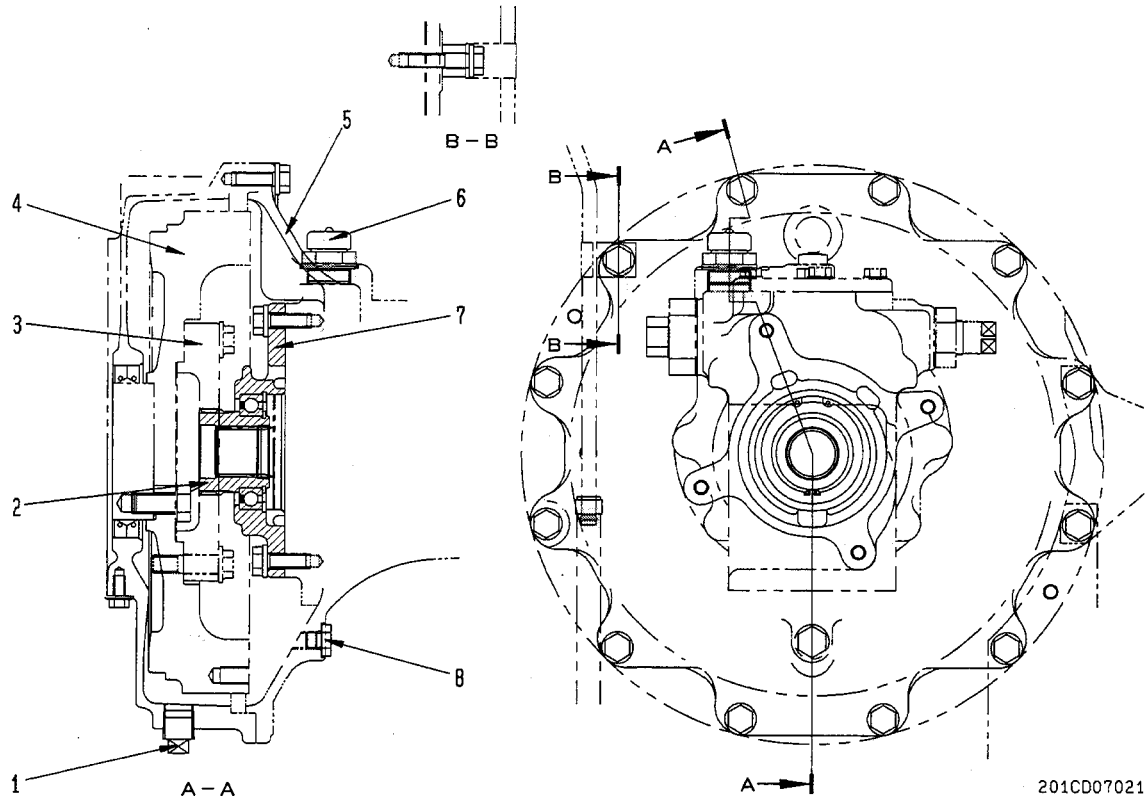

201CD07021

- 1. Drain plug
- 2. Shaft
- 3. Coupling
- 4. Flywheel

- 5. Pump case
- 6. Breather / oil filler plug
- 7. Cage
- 8. Level plug

HYDRAULIC PIPING DRAWING

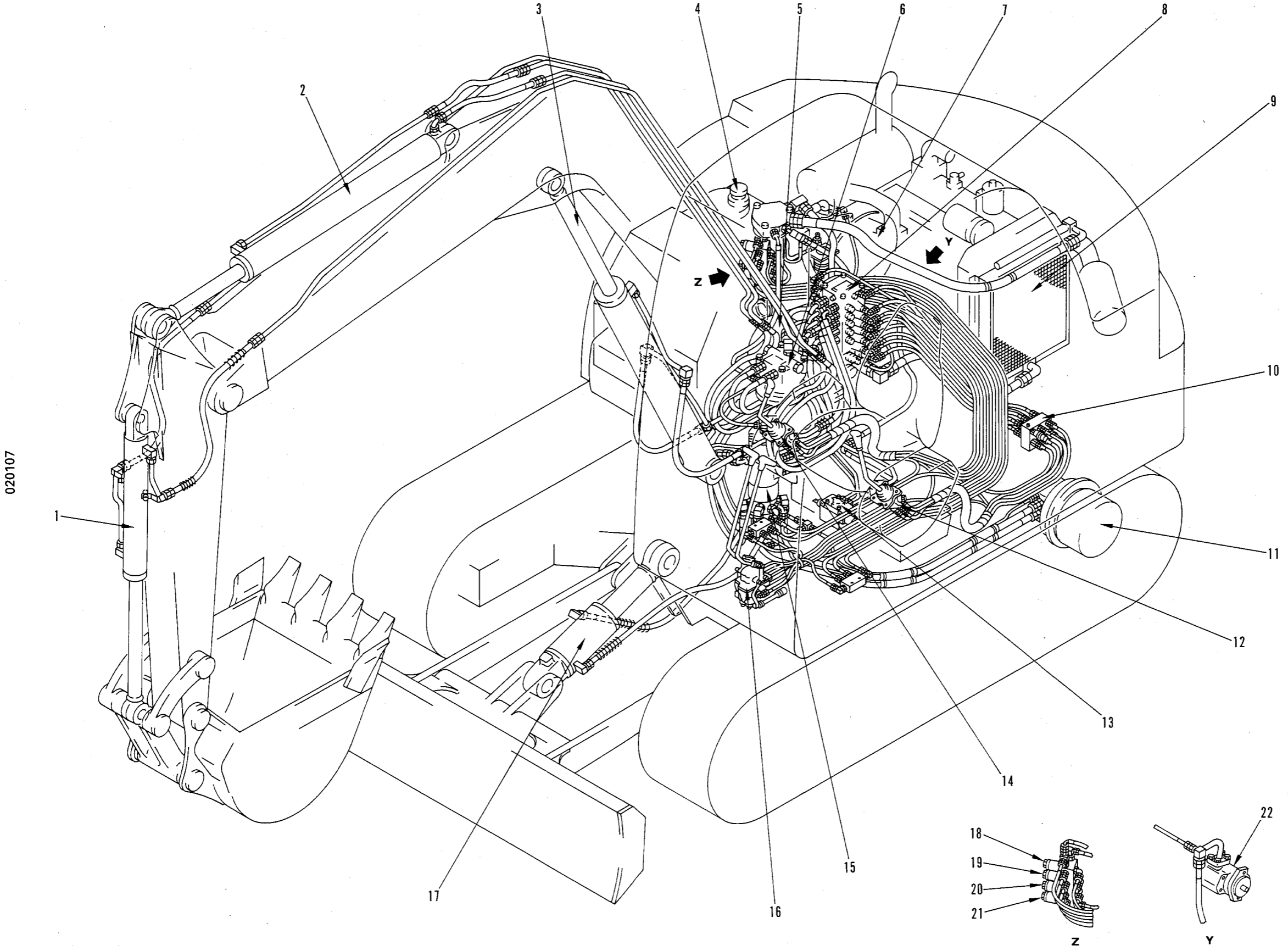

- 1. Bucket cylinder
- 2. Arm cylinder
- 3. Boom cylinder
- 4. Hydraulic tank
- 5. R.H. travel motor
- 6. Swing motor
- 7. Hydraulic pump
- 8. Control valve
- 9. Oil cooler
- 10. PPC shuttle valve
- 11. L.H. travel motor
- 12. L.H. work equipment PPC valve
- 13. Blade control valve (Blade type only)
- 14. R.H. work equipment PPC valve
- 15. Center swivel joint
- 16. Travel PPC valve
- 17. Blade cylinder (Blade type only)
- 18. PPC lock solenoid valve
- 19. Swing lock solenoid valve
- 20. Travel speed control solenoid valve
- 21. Mode switch solenoid valve
- 22. Blade pump (Blade type only)

201F07005

2. TCC VALVE, LS VALVE, SERVO PISTON

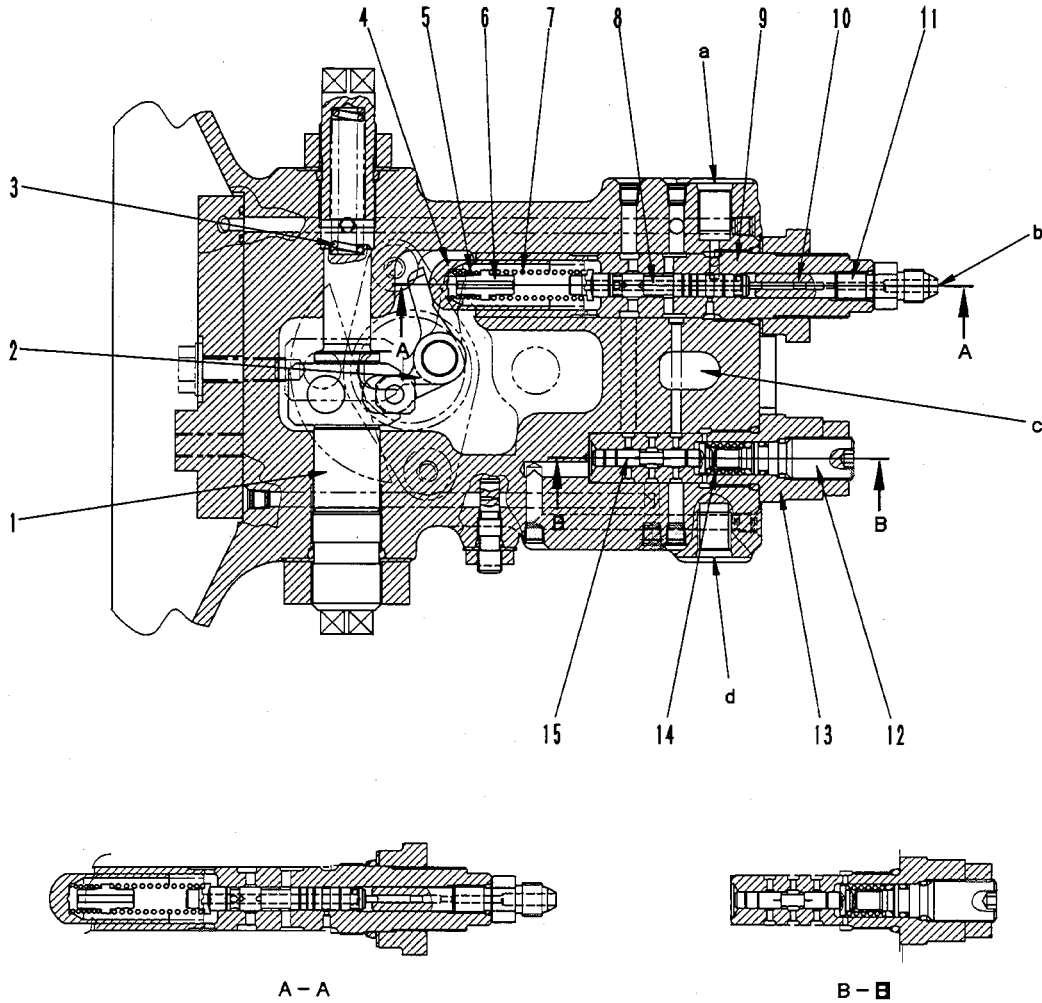

020107

SAP01490

- a. Port **PA3** (Blade pump pressure inlet)
- b. Port **PM** (Mode switch solenoid pressure inlet)
- c. Port **Pp** (Main pump pressure port)
- d. Port **PLs** (Control valve LS pressure inlet)

Servo Piston

- 1. Servo piston
- 2. Lever
- 3. Spring

TCC VALVE

- 4. Piston
- 5. Spring
- 6. Seat
- 7. Spring
- 8. Piston
- 9. Sleeve
- 10. Piston
- 11. Plug

LS VALVE

- 12. Plug
- 13. Sleeve
- 14. Spring
- 15. Piston

TCC VALVE

FUNCTION

- The **TCC** valve carries out an approximate equal horse-power control so that the hydraulic horsepower sucked by the pump does not exceed the engine horsepower by limiting the discharge amount **Q** to a specified amount in relation with the discharge pressure **Pp**, even if the **LS** valve tries to increase the pump discharge amount **Q** when the discharge pressure **Pp** becomes high and opening area of the control valve is large.
- In other words, when a load becomes large during operation and the pump discharge pressure **Pp** rises, the **TCC** valve reduces the pump discharge amount **Q**, and when the pump discharge pressure **Pp** lowers, it increases the pump discharge amount **Q**.
- Relationship between the pump discharge pressure **Pp** and the pump discharge amount **Q** is as shown in the chart.

Normally, it is set to the pump suction torque of the standard mode, but when a signal from the mode switching solenoid valve is inputted, the pump suction horsepower lowers by approximately 15% as shown by the light-load mode curve.

- Furthermore, for the blade type models, since the blade pump is mounted separately from the main pump, when the blade pump is in operation, suction torque of the main pump is reduced by the amount sucked by the blade pump so that the sum of the main pump suction torque and the blade pump suction torque becomes the total suction torque (100%).

Standard type

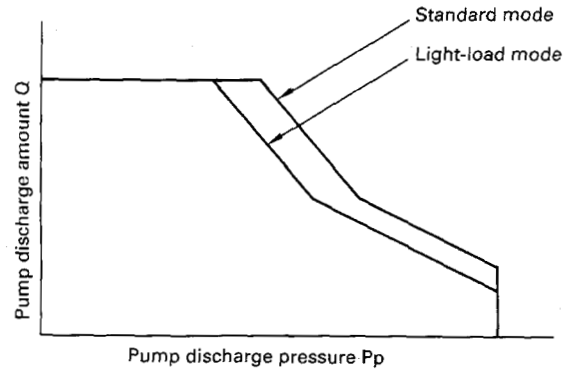

201F07014

Blade type

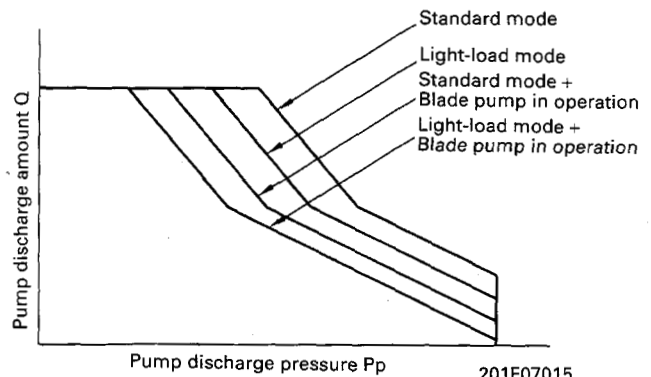

201F07015

020107

BLADE PUMP

Blade type models

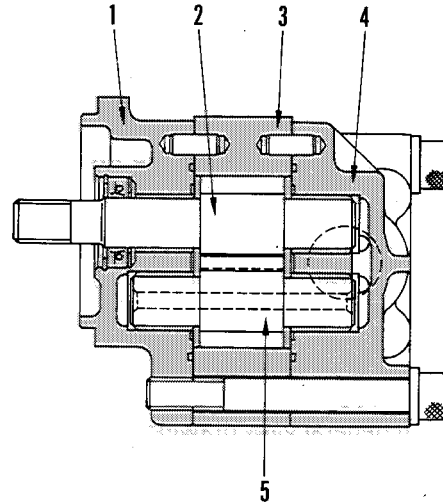
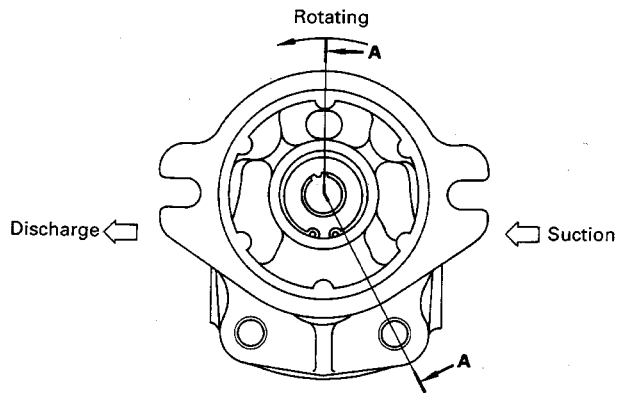

020107

201F06417

1. Bracket
2. Drive gear
3. Housing
4. Cover
5. Driven gear

SPECIFICATIONS

Type : SBL21
Theoretical delivery : 21.0 cc/rev
Set pressure : 20.6 MPa (210 kg/cm²)

020107

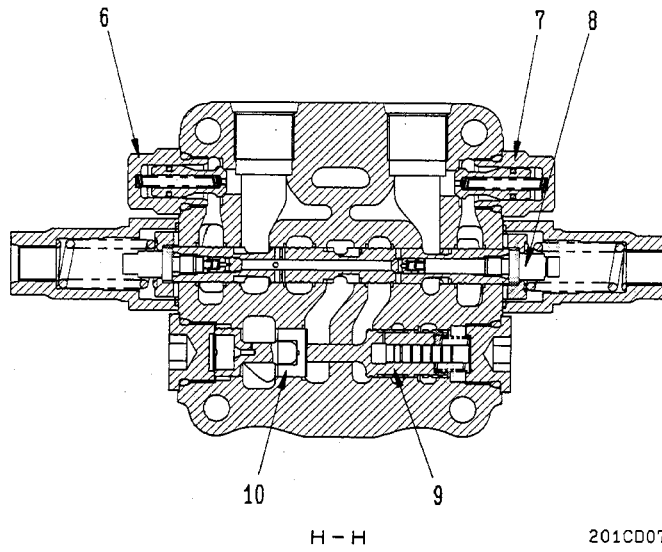
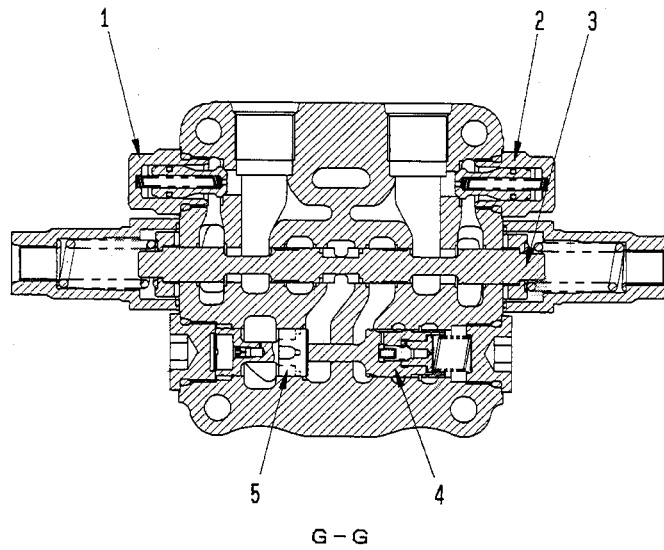

201CD07045

L.H. and R.H. TRAVEL VALVE

- 1. Suction valve (A)
- 2. Suction valve (B)
- 3. Spool
- 4. Pressure compensation valve R
- 5. Pressure compensation valve F

BOOM VALVE

- 6. Suction valve (bottom)
- 7. Suction valve (head)
- 8. Spool
- 9. Pressure compensation valve R
- 10. Pressure compensation valve F

2) Introduction of LS pressure

FUNCTION

- The **LS** pressure denotes the actuator load pressure at the outlet port of the control valve.
- Actually, in the control valves, the pump pressure **Pp** is reduced to the same pressure of the actuator circuit pressure **A** by the pressure reducing valve (3) in the pressure compensation valve before introducing into the **LS** circuit **PLs**.
Furthermore, the orifice **C** is provided in the middle of the circuit from the pump circuit **Pp** to the pressure reducing valve (3) for damper function.
- In the travel valves, the actuator circuit pressure **A** is directly introduced into the **LS** circuit **PLs**.

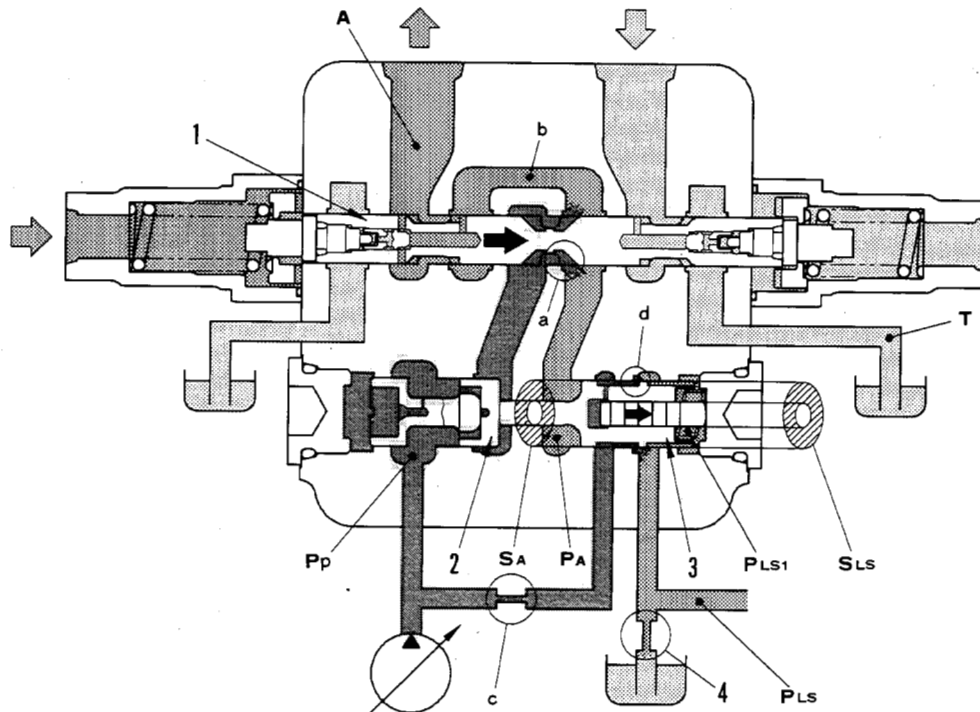

020107

201F07029

OPERATION

1. Control valves (boom, arm, bucket, swing)

- When the spool (1) is operated, the pump pressure **Pp** starts to flow to the actuator circuit **A** from the flow control valve (2) and the spool notch **a** through the bridge path **b**.
- At the same time, the pressure reducing valve (3) moves to the right (➡) side, so the pump pressure **Pp** introduced from the orifice **c** is depressurized by the pressure loss at the notch **d** and introduced to the **LS** circuit **PLs**, and then, further introduced to the spring chamber **PLs1**.
- At this time, the **LS** circuit **PLs** is open to the tank circuit **T** through the **LS** bypass plug (4) (refer to the description of the **LS** bypass plug).
- Areas of the both ends of the pressure reduc-

ing valve (3) are same (**SA = SLS**), and on the **SA** side, the actuator circuit pressure **PA (=A)** is acting, and on the opposite **SLS** side, the reduced pump pressure **Pp** is acting.

- Therefore, the pressure reducing valve (3) balances at the point where the actuator circuit pressure **PA** and the spring chamber pressure **PLs1** are balanced, and the pump pressure **Pp** reduced by the notch **d** is introduced to the **LS** circuit **PLs** as the actuator circuit pressure **A**.

- When lowering the boom, if the head pressure **B** of the cylinder (1) is greater than the bottom pressure **A**, and the operation is in the load process, the check valve (3) closes to shut off the circuit between the head and the bottom sides.

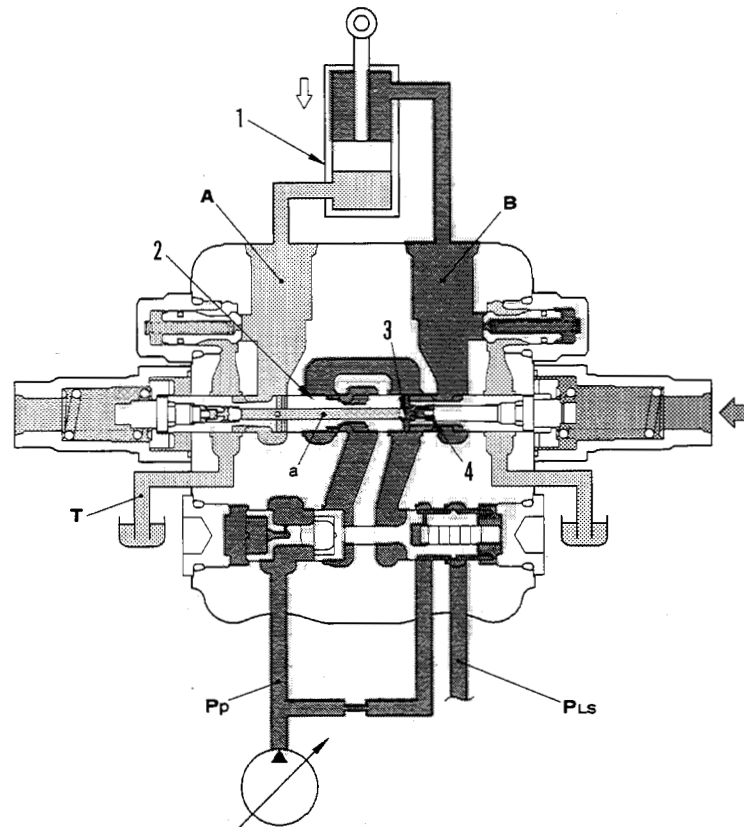

020107

201F07039

OPERATION

- During a load process such as lowering the boom, etc., the pressure **B** at the head side of the boom cylinder (1) becomes higher than the pressure **A** at the bottom side.
- At this time, the check valve (3) is closed by the pressure **B** at the head side and the spring (4), and the passage between the head circuit and the bottom circuit is shut off.

020107

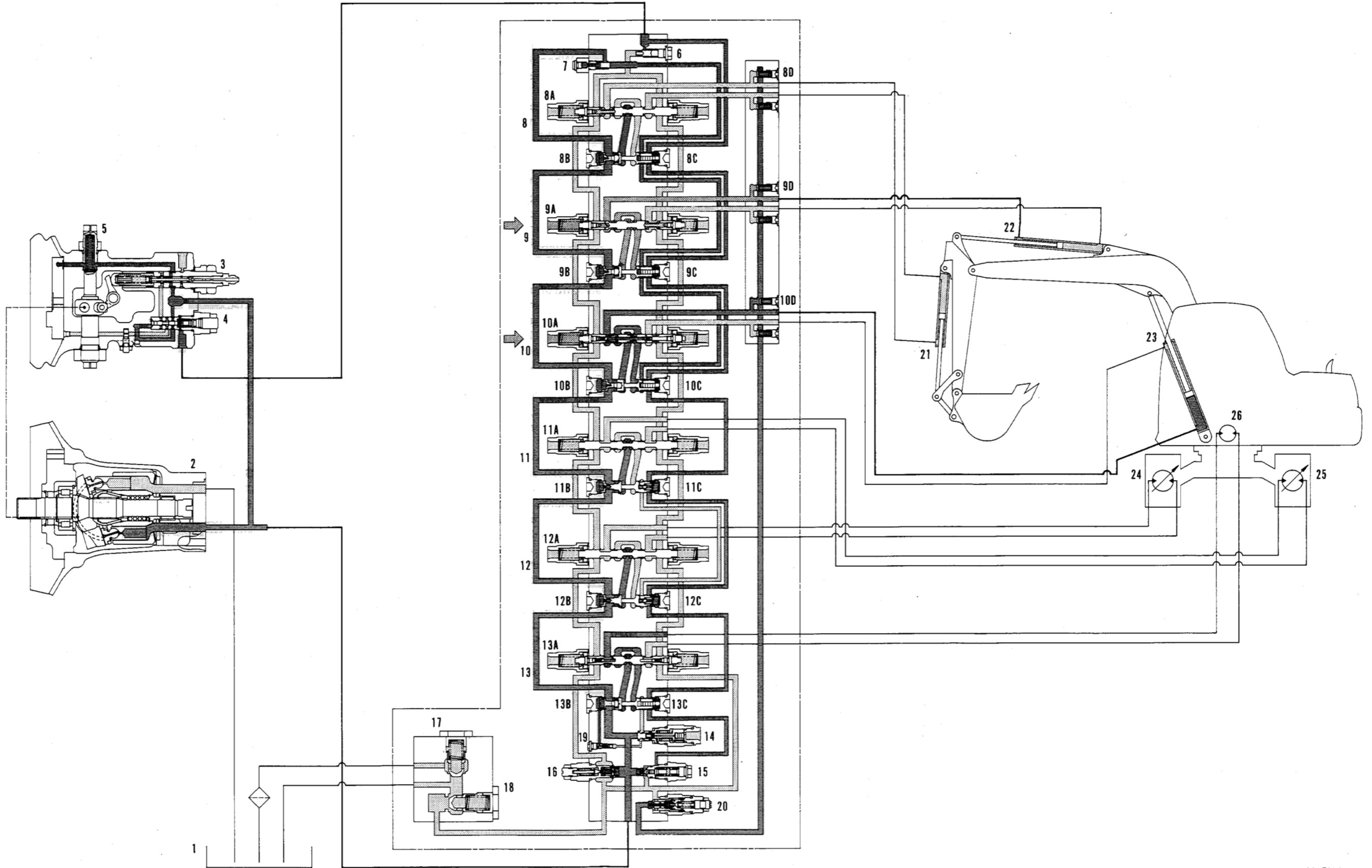

201F07045

10-85

TRAVEL MOTOR

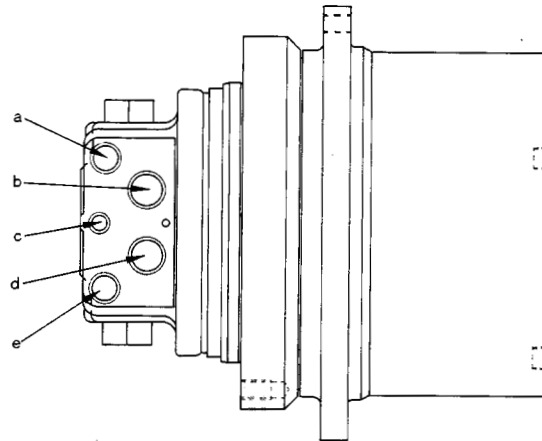
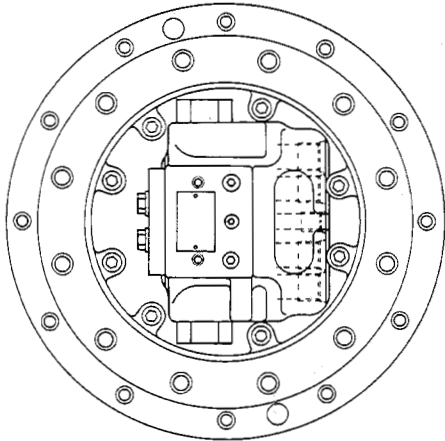

201F07051

020107

- a. Port **C1** (to the tank)
- b. Port **A** (from the control valve)
- c. Port **D** (from the travel speed solenoid valve)
- d. Port **B** (from the control tank)
- e. Port **C2** (to the tank)

SPECIFICATIONS

Type : GM09VL

Hydraulic motor

Motor capacity : Lo 39.7 cc/rev
Hi 27.5 cc/rev

Number of revolution : Lo 1,785 rpm
Hi 2,557 rpm

Brake releasing pressure : 0.9 MPa (9 kg/cm²)
Hi-Lo switching pressure : 2.9 MPa (30 kg/cm²)

Final drive

Reduction ratio : 57

Number of revolution : Lo 31.5 rpm
Hi 44.9 rpm

3. During fine control (when the lever is re-turned)

When the disc (5) starts to be returned, the spool (1) is pushed up by the force of the centering spring (3) and the P₁ port pressure.

By this the fine control hole f opens to the drain chamber D and the pressure oil at the P₁ port is released.

If the pressure at the P₁ port drops too far, the spool (1) is pushed up by the measuring spring (2), the fine control hole f is shut off from the drain chamber D, and almost at the same time, it is connected to the pump pressure chamber P_p to supply pump pressure until the pressure at the P₁ port recovers the pressure corresponding to the lever position.

When the spool of the control valve returns, oil in the drain chamber D flows in from the fine control hole f' of the valve at the side that is not working. The oil is then introduced to the chamber B through the P₂ port to fill the chamber with oil (Fig. 3).

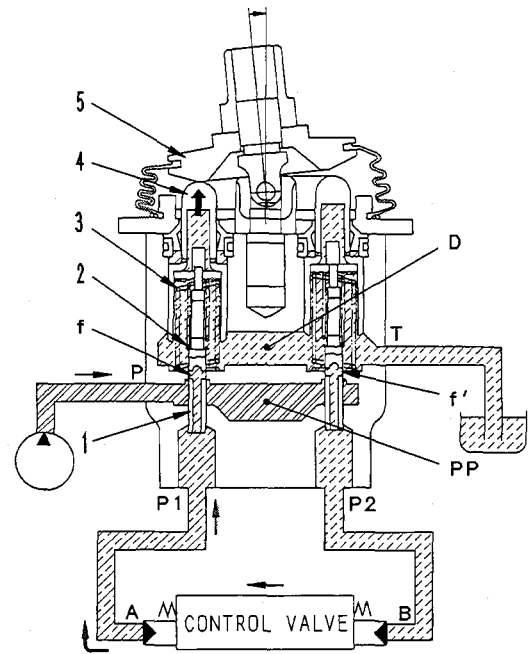

(Fig. 3)

SBP01738

4. At full stroke

When the disc (5) pushes down the piston (4) and the retainer (9) pushes down the spool (1), the fine control hole f is shut off from the drain chamber D and connected to the pump pressure chamber P_p. Therefore, the pilot pressure oil from the control pump passes the fine control hole f, enters into the chamber A through the P₁ port, and pushes the spool of the control valve.

Return oil from the chamber B passes the fine control hole f' through the P₂ port and flows into the drain chamber D (Fig. 4).

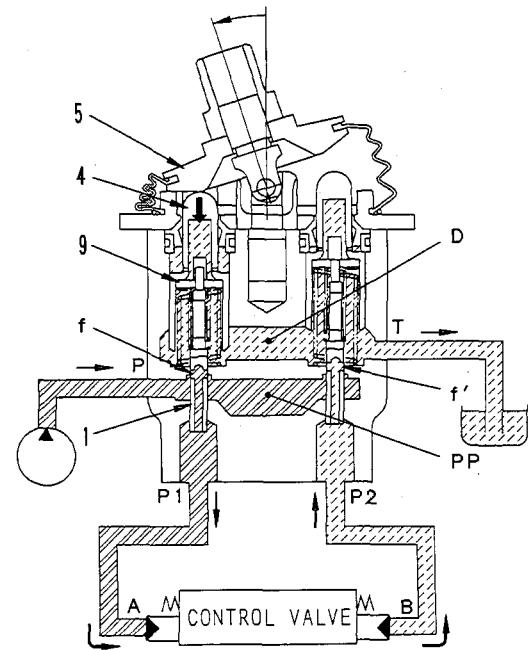

(Fig. 4)

SBP01739

020107

**3) During fine control
(when control lever is returned)**

When lever (5) starts to be returned, spool (1) is pushed up by the force of centering spring (3) and the pressure at port P1.

When this happens, fine control hole f is connected to drain chamber D and the pressure oil at port P1 is released.

If the pressure at port P1 drops too far, spool (1) is pushed down by metering spring (2), and fine control hole f is shut off from drain chamber P1. At almost the same time, it is connected to pump pressure chamber Pp, and the pump pressure is supplied until the pressure at port P1 recovers to a pressure that corresponds to the lever position.

When the spool of the control valve returns, oil in drain chamber D flows in from fine control hole f' in the valve on the side that is not working. The oil passes through port P2 and enters chamber B to fill the chamber with oil. (Fig. 3)

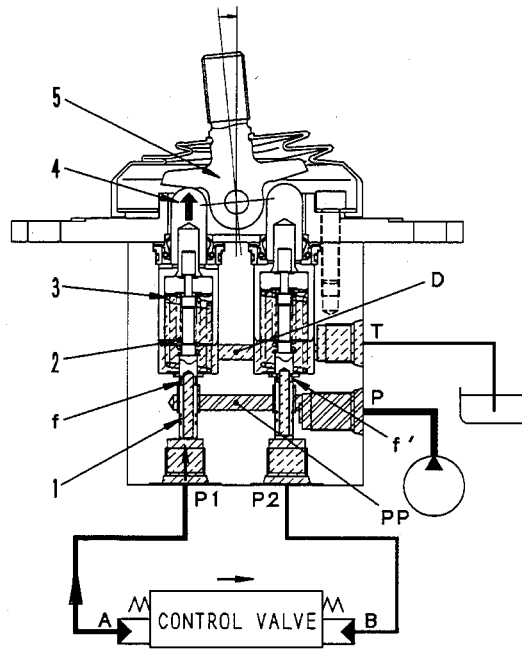

(Fig. 3)

SAP01742

(Fig. 3)

4) At full stroke

When lever (5) pushes down piston (4), and retainer (7) pushes down spool (1), fine control hole f is shut off from drain chamber D, and is connected with pump pressure chamber Pp. Therefore, the pilot pressure from the control pump passes through fine control hole f and flows to chamber A from port P1, and pushes the control valve spool.

The oil returning from chamber B passes from port P2 through fine control hole f' and flows to drain chamber D. (Fig. 4)

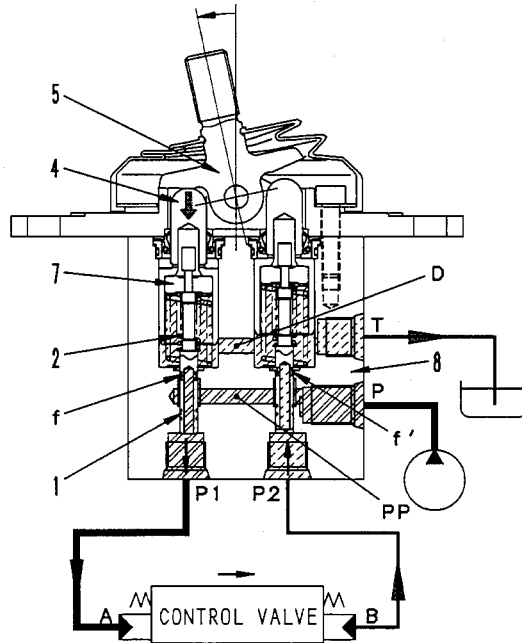

(Fig. 4)

SAP01743

(Fig. 4)

020107

3. COMPONENTS OF THE SYSTEM

1) Controller

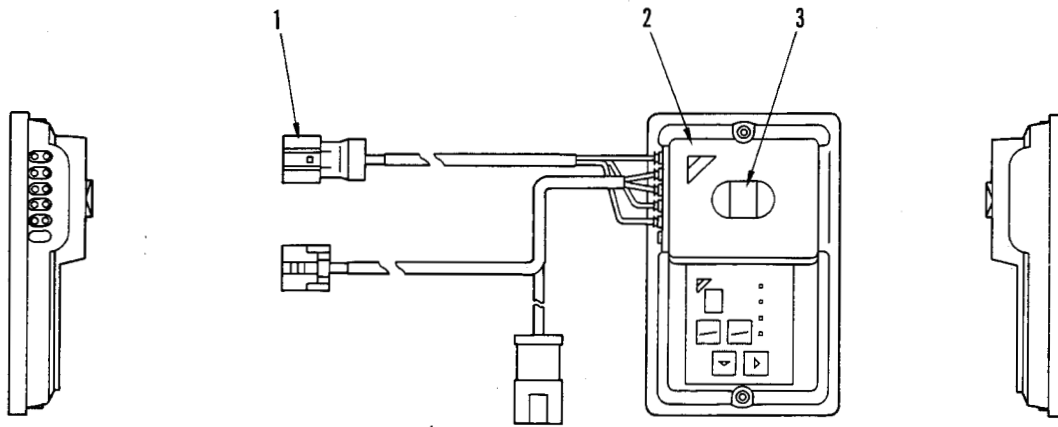

- 1. Connector
- 2. Controller
- 3. Fuse

SPECIFICATIONS

Type : LC2MP

I/O signal

CN-P44

No.	Signal name	I/O
1	Power supply +24V	—
2	GND	—
3	—	—
4	Abnormality signal	Output
5	Boom UP signal	Input
6	Starting switch ON signal	Input

020107

201F07066

ELECTRICAL WIRING DIAGRAM

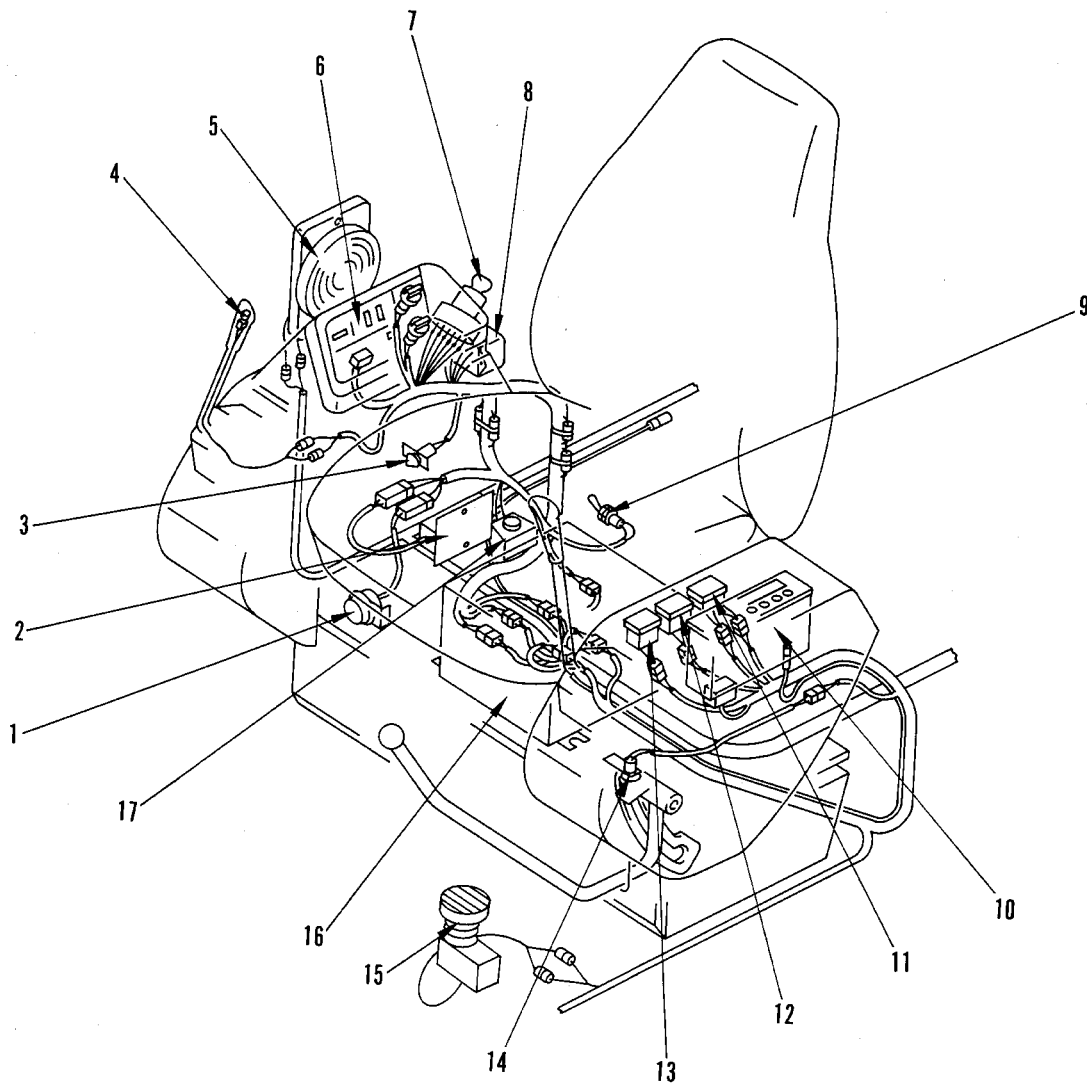

020107

201F07079

- | | |
|-----------------------------|--|
| 1. Alarm buzzer | 10. Radio |
| 2. Swing brake controller | 11. Wiper switch |
| 3. Fuel lever limit switch | 12. Swing lock switch |
| 4. Horn switch | 13. Travel speed switch (for STD type) |
| 5. Speaker | 14. PPC lock limit switch |
| 6. Monitor panel | 15. Travel accelerator switch (for blade type) |
| 7. Starter switch | 16. Heater |
| 8. Fuse box | 17. Glow resistance |
| 9. Swing lock prolix switch | |

4. ONE-TOUCH DECELERATION SWITCH

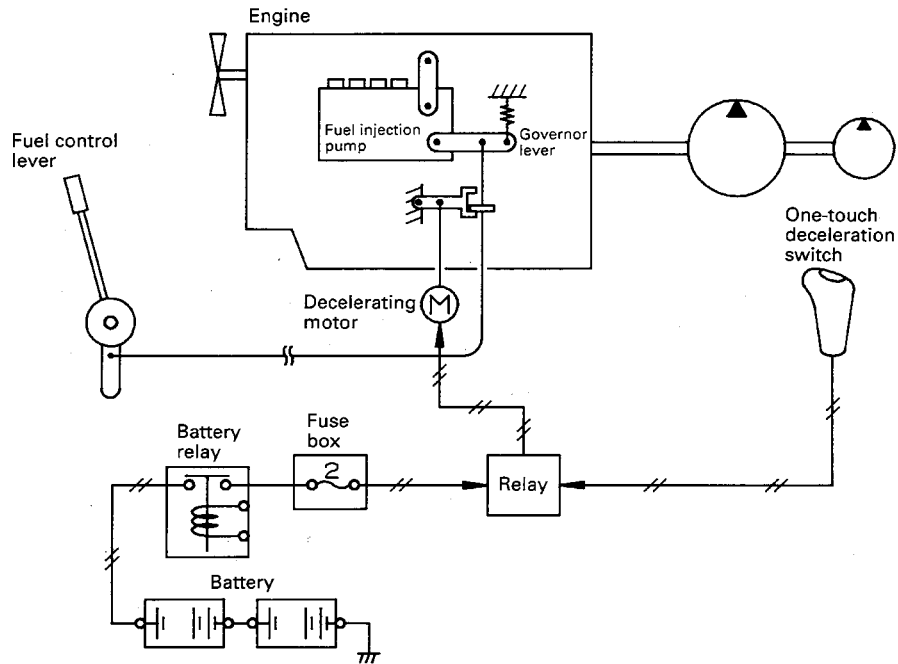

020107

201F07089

FUNCTION

- When the vehicle is placed in a waiting status for a moment due to waiting for work or waiting for a dump truck, by pushing the one-touch deceleration switch on the top of the left lever, engine speed will be lowered immediately to the deceleration speed to reduce fuel consumption and noise.
- To restart the operation, push the switch again, and the engine speed will rise to the set speed immediately.

OPERATION

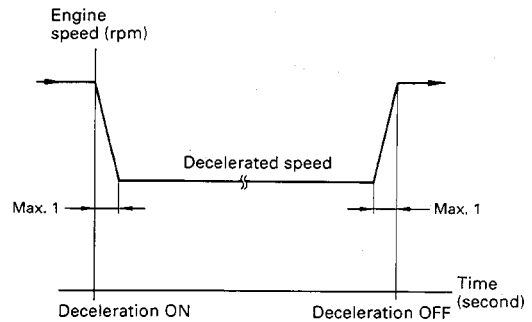

201F07090

• FOR CHASSIS

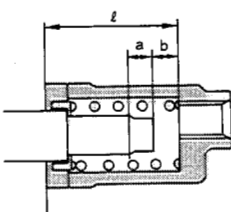
Machine model				PC60-7						
Category	Item	Measurement conditions	Unit	Standard value			Permissible value			
Engine speed	1 pump relief (LS relief)	<ul style="list-style-type: none"> Hydraulic oil temperature: 45 – 55 °C Coolant temperature: within operating range 1 pump relief: arm relief 	rpm	Min. 1,800			Min. 1,800			
Spool stroke	Boom control valve		mm	l	a	b	l	a	b	
	Arm control valve			6.5±0.3	16±0.1	9.5±0.1	6.5±0.3	16±0.1	9.5±0.1	
	Bucket control valve									
	Swing control valve									
	Travel control valve									
			202F2302							
Control lever stroke	Boom control lever	<ul style="list-style-type: none"> Center of the lever knob Read the max. value to the end of stroke Engine stopped Excluding neutral play 	mm	100 ± 10			100 ± 10			
	Arm control lever			100 ± 10			100 ± 10			
	Bucket control lever			100 ± 10			100 ± 10			
	Swing control lever			100 ± 10			100 ± 10			
	Travel control lever			115 ± 15			115 ± 15			
	Fuel control lever			Slow → Full	140 ± 20			140 ± 20		
	Play of control lever				Boom, bucket, arm, swing	Max. 5			Max. 5	
Travel lever		Max. 10			Max. 10					
Fuel control lever		Max. 30			Max. 30					
Operating force of control levers	Boom control lever	<ul style="list-style-type: none"> Engine at full speed Hydraulic oil temperature: 45 – 55 °C Fit a push-pull scale to the center of the control lever knob to measure Read the max. value to the end of stroke 	N (kg)	15.7 ± 4.9 (1.6 ± 0.5)			15.7 ± 4.9 (1.6 ± 0.5)			
	Arm control lever			13.7 ± 4.9 (1.4 ± 0.5)			13.7 ± 4.9 (1.4 ± 0.5)			
	Bucket control lever			13.7 ± 4.9 (1.4 ± 0.5)			13.7 ± 4.9 (1.4 ± 0.5)			
	Swing control lever			15.7 ± 4.9 (1.6 ± 0.5)			15.7 ± 4.9 (1.6 ± 0.5)			
	Travel control lever			16.7 ± 4.9 (1.7 ± 0.5)			16.7 ± 4.9 (1.7 ± 0.5)			
	Fuel control lever			Slow → Full	68.6 ± 14.7 (7 ± 1.5)			68.6 ± 14.7 (7 ± 1.5)		

020107

LIST OF EQUIPMENTS FOR INSPECTION, ADJUSTMENT AND TROUBLE-SHOOTING

Inspection/adjustment item	Symbol	Part No.	Part Name	Remarks	
Engine speed	A	1	799-203-9000	Multi-tachometer	Digital display L : 60 — 2,000 rpm H : 60 — 19,999 rpm
		2	6210-81-4111	Gear box	
Coolant and oil temperature	B	799-101-1502	Digital thermometer	-50 — 1,200 °C	
Hydraulic oil pressure	1	799-101-5002	Hydraulic tester	Pressure gauge : 2.45(25), 5.88(60), 39.2(400), 58.8(600) MPa(kg/cm ²)	
		790-261-1203	Digital hydraulic tester	Pressure gauge : 68.6 MPa (700 kg/cm ²)	
	2	799-401-2320	Hydraulic gauge	0.98 MPa (10 kg/cm ²)	
	3	•790-261-1311	Adapter	Both male and female 14 × 1.5 (female PT1/8)	
		•790-261-1321		Both male and female 18 × 1.5 (female PT1/8)	
		•790-261-1331		Both male and female 22 × 1.5 (female PT1/8)	
	4	799-401-2700	Differential pressure gauge	—	
	5	•790-261-1360	Adapter	Both male and female 14 × 1.5 (female PT1/8)	
		•790-261-1370	Nut	For 14 × 1.5 blind	
		•07003-31419	Gasket	For blind	
Compression pressure	D	1	795-502-1590	Compression gauge	0 — 6.86 MPa (0 — 70 kg/cm ²) Kit No.: 795-502-1205
		2	790-553-1110	Adapter	
Blowby pressure	E	799-201-1504	Blowby checker	0 — 4.9 KPa (0 — 500 mmH ₂ O)	
Valve clearance	F	Commercially available	Feeler gauge	—	
Exhaust gas color	G	1	799-201-9000	Handy smoke checker	Discoloration 0 — 79 % (with standard color samples) (Discoloration × 1/10 Bosch index)
		2	Commercially available	Smoke meter	
Operating force	H	79A-264-0020	Push-pull scale	0 — 294 N (0 — 30 kg)	
		79A-264-0090		0 — 490 N (0 — 50 kg)	
Stroke, hydraulic drift	I	Commercially available	Scale	—	
Work equipment speed	J	Commercially available	Stop watch	—	
Voltage and resistance measurement	K	79A-264-0210	Tester	—	
Sensor harness diagnosis	L	1	799-601-2600	T-adapter box	—
		2	799-601-7000	Adapter assembly	
Air breeding from the auto lubricator piping	M	1	21F-38-11390	Bushing	—
		2	07020-00000	Fitting	
Fuel injection timing	N	1	795-102-2102	Spring pusher	For 4D95LE-1 engine
		2	Commercially available	Dial gauge	

020107

MEASURING ENGINE OIL PRESSURE

- ★ Measure the engine oil pressure under the following conditions.
 - Coolant temperature: Within operating range
- 1. Remove engine oil pressure sensor (1), then install the adapter of oil pressure gauge kit **C1** and oil pressure gauge **C2** (0.98 MPa (10 kg/cm²)).
- 2. Start the engine, and measure the oil pressure at the low pressure end with the engine at low idling and at the high pressure end with the engine at high idling.

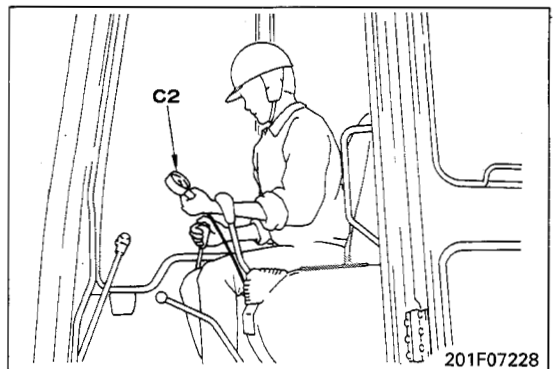
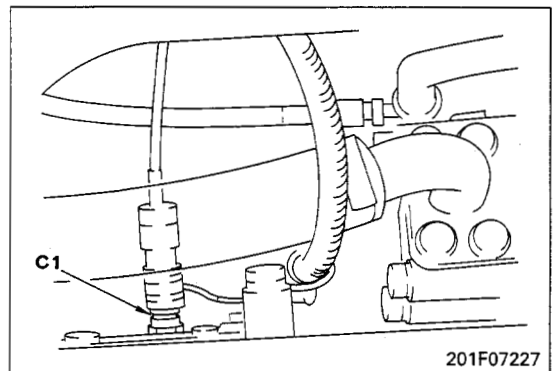
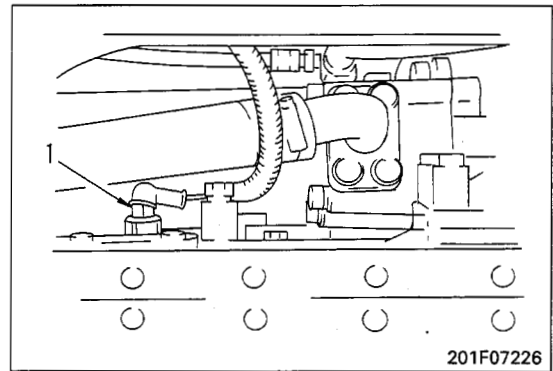

020107

2. Adjusting

Loosen locknut (2) and turn adjustment screw (3) to adjust.

- ★ Turn the adjustment screw as follows.
 - To INCREASE pressure, turn CLOCKWISE
 - To DECREASE pressure, turn COUNTER-CLOCKWISE
- ★ Amount of adjustment for one turn of adjustment screw: 0.53 MPa (5.4 kg/cm²)

 Locknut : 63.7 ± 9.8 Nm
(6.5 ± 1.0 kgm)

- ★ After completion of adjustment, repeat the procedure in MEASURING to check the set pressure again.

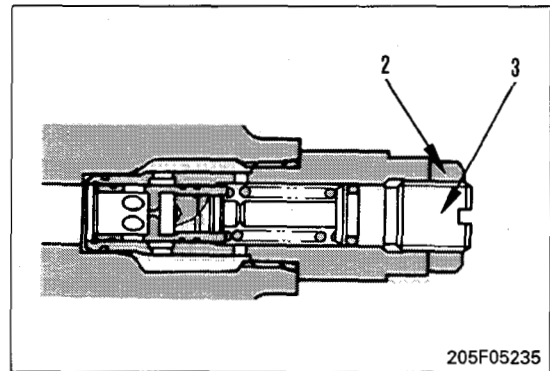

BLEEDING AIR

Order for operations and procedure for bleeding air

Air bleeding item Nature of work	Air bleeding procedure				
	1	2	3	4	5
	Bleeding air from pump	Start engine	Bleeding air from cylinder	Bleeding air from travel motor	Start operations
<ul style="list-style-type: none"> • Replace hydraulic oil • Clean strainer 	○	→ ○	→ ○	→ ○ (Note 1)	→ ○
<ul style="list-style-type: none"> • Replace return filter element 		○	→ ○	→ ○	→ ○
<ul style="list-style-type: none"> • Replace, repair pump • Remove suction piping 	○	→ ○	→ ○	→ ○	→ ○
<ul style="list-style-type: none"> • Replace, repair control valve 		○	→ ○	→ ○	→ ○
<ul style="list-style-type: none"> • Replace cylinder • Remove cylinder piping 		○	→ ○	→ ○	→ ○
<ul style="list-style-type: none"> • Replace swing motor • Remove swing motor piping 		○	→ ○	→ ○	→ ○
<ul style="list-style-type: none"> • Replace travel motor, swivel • Remove travel motor, swivel piping 		○	→ ○	→ ○	→ ○

Note 1: Bleed the air from the travel motors only when the oil inside the motor case has been drained.

020107

1. Bleeding air from pump

- 1) Loosen air bleed plug (1), and check that oil oozes out from the plug.
- 2) When oil oozes out, tighten plug(1).

 Plug : $17.2 \pm 2.5 \text{ Nm}$
($1.75 \pm 0.25 \text{ kgm}$)

- ★ Precautions when starting the engine
After completing the above procedure and starting the engine, run the engine at low idling for 10 minutes.

2. Bleeding air from hydraulic cylinders

- 1) Start the engine and run at idling for approx. 5 minutes.
- 2) Run the engine at low idling, then raise and lower the boom 4 – 5 times in succession.
 - ★ Operate the piston rod to approx. 100 mm before the end of its stroke. Do not relieve the circuit under any circumstances.

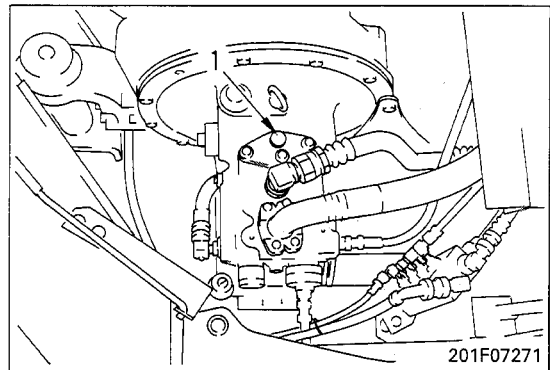

020107

Confirmation method of depressurizing spool indicator

1. The position of the depressurizing spool indicator (1) can be visually checked by removing the screw (3) and cap (2) at the side of the pump.

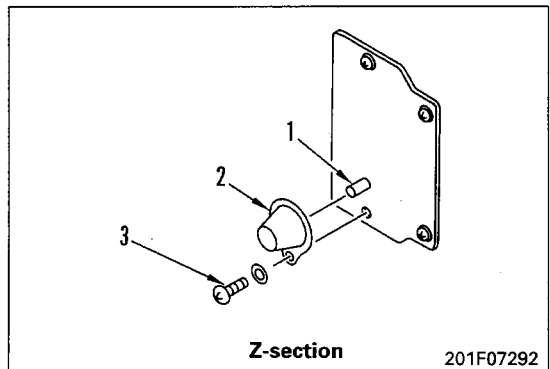
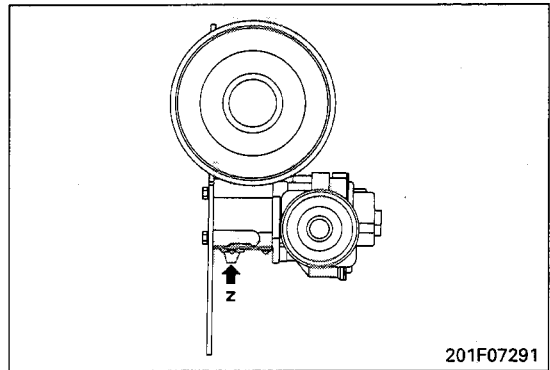

2. During depressurizing process and waiting process, the depressurizing spool indicator is coming out from the pump body by approx. 7.5mm.
3. During the pressurizing process and pressure holding process, the depressurizing spool indicator is stored in the pump body without any protrusion.

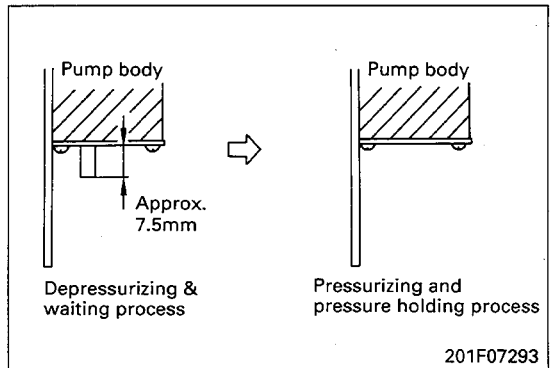

- **Drying wiring harness**

If there is any oil or dirt on the wiring harness, wipe it off with a dry cloth. Avoid washing it in water or using steam. If the connector must be washed in water, do not use high-pressure water or steam directly on the wiring harness.

If water gets directly on the connector, do as follows.

- ① Disconnect the connector and wipe off the water with a dry cloth.
 - ★ If the connector is blown dry with compressed air, there is the risk that oil in the air may cause defective contact, so remove all oil and water from the compressed air before blowing with air.

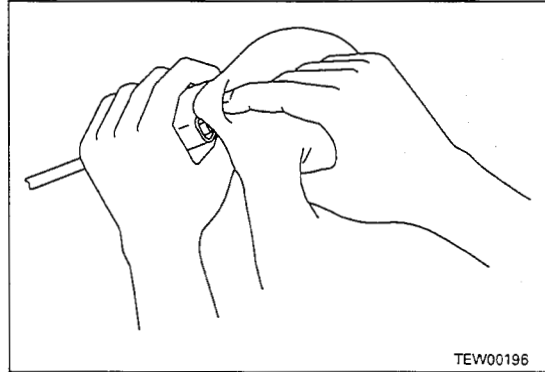

- ② Dry the inside of the connector with a dryer. If water gets inside the connector, use a dryer to dry the connector.
 - ★ Hot air from the dryer can be used, but regulate the time that the hot air is used in order not to make the connector or related parts too hot, as this will cause deformation or damage to the connector.

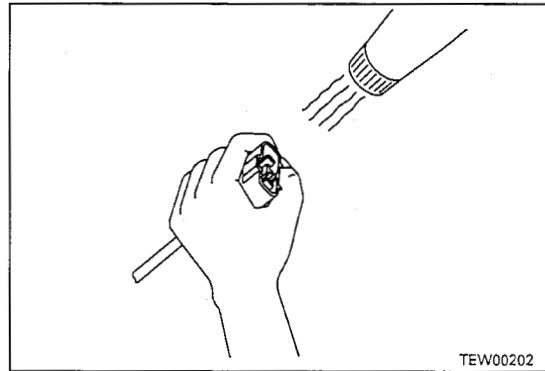

- ③ Carry out a continuity test on the connector. After drying, leave the wiring harness disconnected and carry out a continuity test to check for any short circuits between pins caused by water.
 - ★ After completely drying the connector, blow it with contact restorer and reassemble.

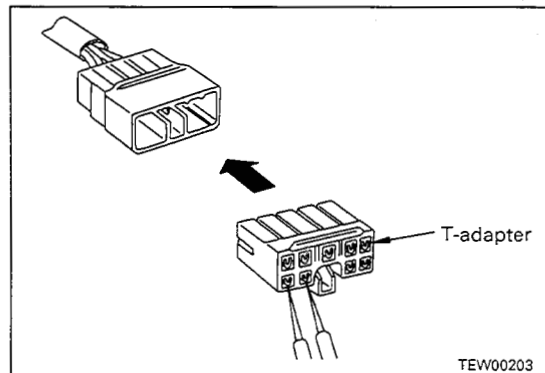

020107



CLICK HERE TO **DOWNLOAD** THE COMPLETE MANUAL

- Thank you very much for reading the preview of the manual.
- You can download the complete manual from: www.heydownloads.com by clicking the link below

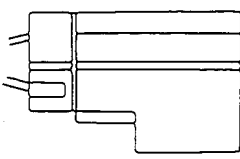
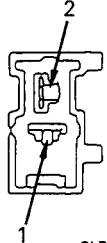
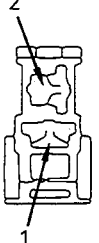
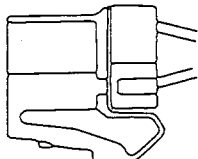
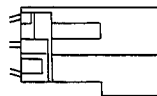
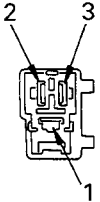

- Please note: If there is no response to CLICKING the link, please download this PDF first and then click on it.

CLICK HERE TO **DOWNLOAD** THE COMPLETE MANUAL

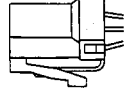
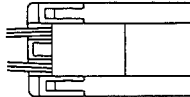
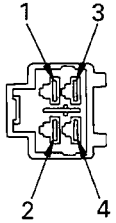
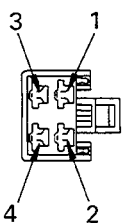
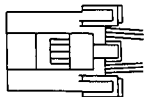
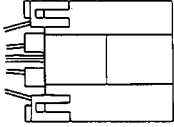
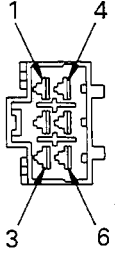
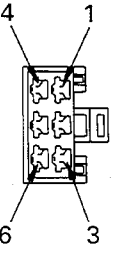
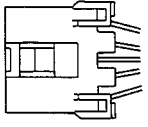
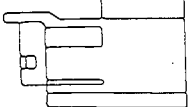
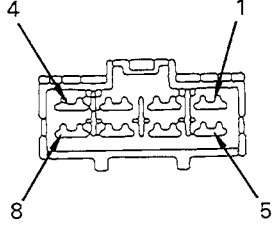
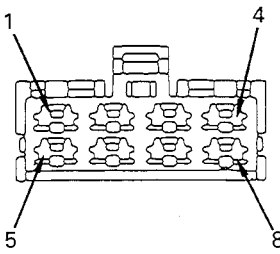
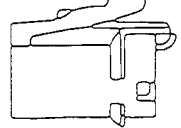
No. of pins	M type connector			
	Male (female housing)		Female (male housing)	
2		 BLP00038		 BLP00039
3		 TEW00243		 TEW00244
4		 TEW00245		 TEW00246
6		 TEW00247		 TEW00248
8		 BLP00040		 BLP00041

020107

<Example>

① **E-6 Power mode cannot be changed**

② a) **Work equipment speed is slow when engine speed is middle and higher**

③

020107

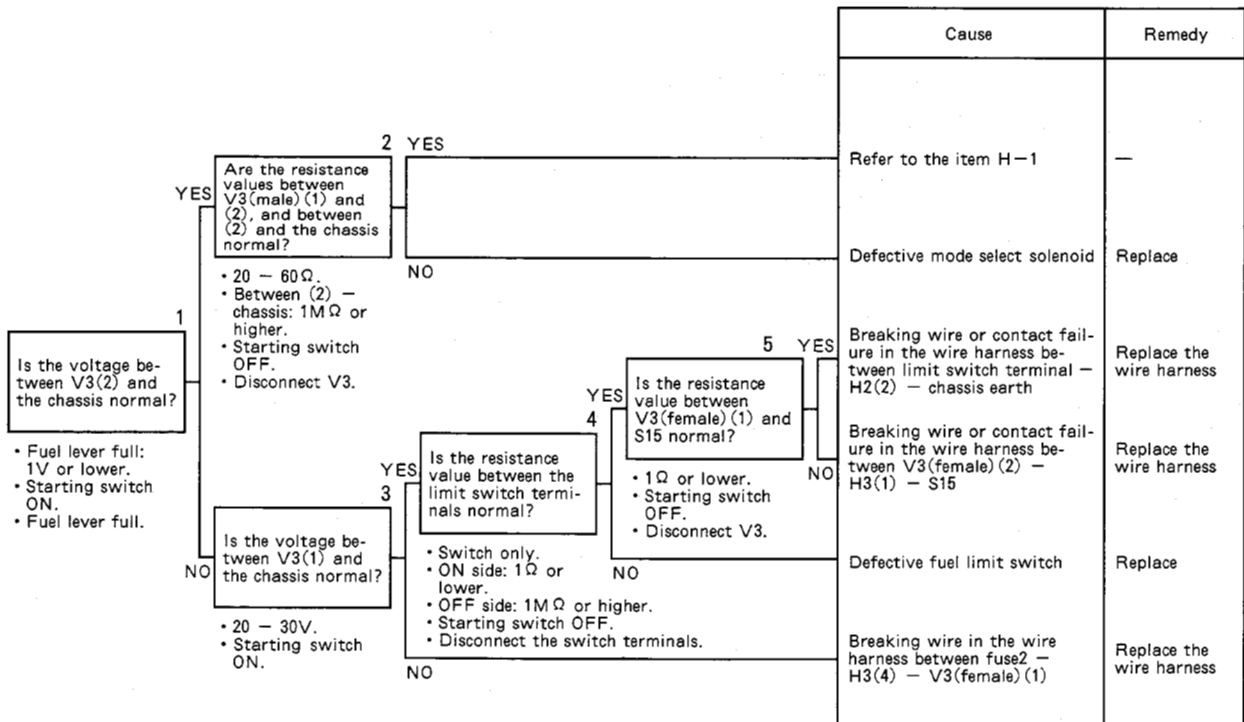

④

- ★ Before carrying out this troubleshooting, check for engagement failure at relating connectors.
- ★ Before proceeding to the next step, make sure to restore removed connectors.
- ★ When the fuse 2 is not blown out.

E-5 Travel speed cannot be switched

- ★ Before carrying out this troubleshooting, check for engagement failure at relating connectors.
- ★ Before proceeding to the next step, make sure to restore removed connectors.
- ★ When the fuse 2 is not blown out.

a) Cannot be switched to Hi

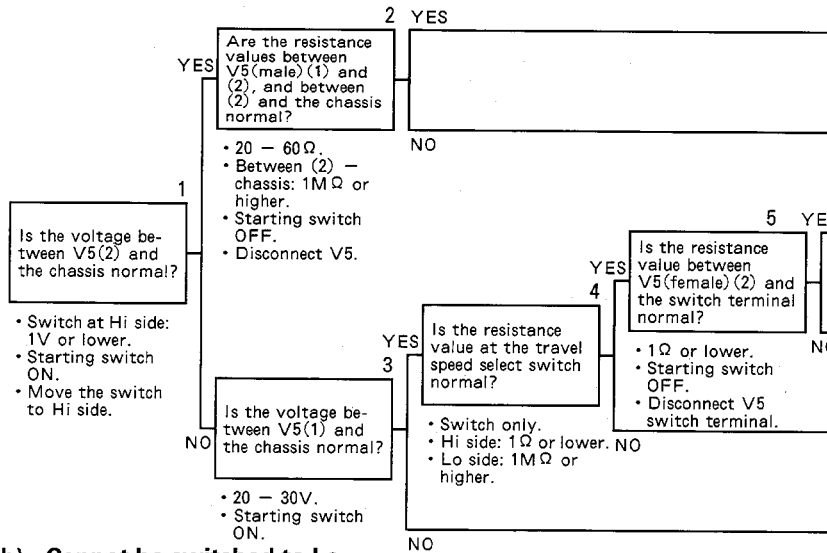

b) Cannot be switched to Lo

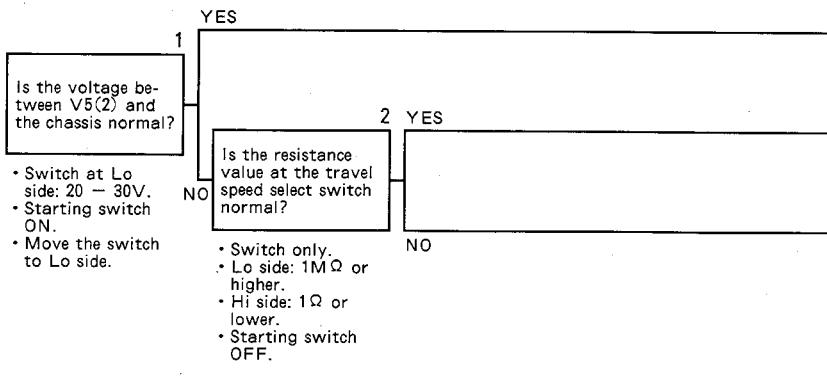

Cause	Remedy
Refer to the item H-20	—
Defective travel speed select solenoid	Replace
Breaking wire or contact failure in the wire harness between select switch terminal (1) - M29(1) - M4(5) - vehicle earth	Replace the wire harness
Breaking wire or contact failure in the wire harness between V5(female)(2) - M4(10) - M29(2) - select switch terminal	Replace the wire harness
Defective travel speed select switch	Replace
Breaking wire in the wire harness between fuse2 - H3(4) - V5(female)(1)	Replace the wire harness
Refer to the item H-20	—
Short-circuit to the ground in the wire harness between V5(female)(2) - M4(10) - M29(2) - Switch terminal(2)	Replace the wire harness
Defective travel speed select switch	Replace

020107

E-5 Related electrical circuit diagram

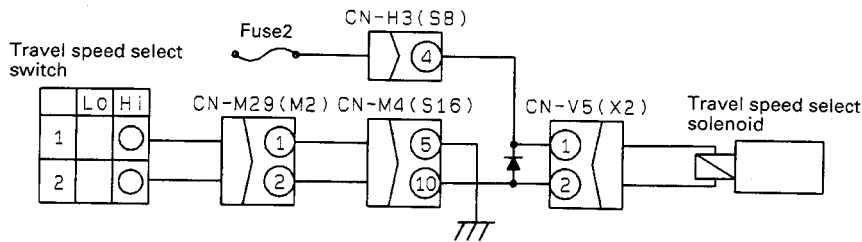

201CA07403

• **Example of troubleshooting when exhaust gas is black**

Let us assume that [Clogged air cleaner] is taken to be the cause of black exhaust gas. Three symptoms have causal relationship with this problem: [Exhaust gas slowly became black], [Power slowly became weaker], and [Dust indicator is red].

If we look from these three symptoms to find the causes, we find that there is a relationship with four causes. Let us explain here the method of using this causal relationship to pinpoint the most probable cause.

S-7 Exhaust gas is black (incomplete combustion)

General causes why exhaust gas is black

- Insufficient intake of air
- Improper condition of fuel injection
- Excessive injection of fuel

		Causes							
		Clogged air cleaner element	Worn piston ring, cylinder	Clogged, seized injection nozzle	Improper injection timing	Defective injection pump (excessive injection)	Crushed, clogged muffler	Defective contact of valve, valve seat	Defective injection pump (rack, plunger seized)
Question	Confirm recent repair history								
	Degree of use	Operated for long period	△	△	△				△
		Suddenly became black			○				○
	Color of exhaust gas	Gradually became black	◎		○				
		Blue under light load		◎					
	Engine oil must be added more frequently		◎						
	Power was lost	Suddenly			○		○		○
		Gradually	○	○				○	
	Non-specified fuel has been used			○					○
	Dust indicator is red	◎							
	Blow-by gas is excessive		◎						
	Engine pickup is poor and combustion is irregular			◎		○	○		○
	When exhaust manifold is touched immediately after starting engine, temperature of some cylinders is low			◎					○
	Match marks on fuel injection pump are out of alignment				◎				
	Seal on injection pump has come off					◎			
Clanging sound is heard from around cylinder head						◎			
Exhaust noise is abnormal			○			◎			
Muffler is crushed						◎			
Troubleshooting	When air cleaner is inspected directly, it is found to be clogged	●							
	When compression pressure is measured, it is found to be low		●					●	
	Speed of some cylinders does not change when operating on reduced cylinders			●					
	When check is made using delivery method, injection timing is found to be incorrect				●				
	Injection pump test shows that injection amount is incorrect					●			
	When valve clearance is checked directly it is found to be outside standard value						●		
	When muffler is removed, exhaust gas color returns to normal							●	
	When control rack is pushed, it is found to be heavy or does not return								●
Remedy	Clean	Replace	Replace	Adjust	Adjust	Adjust	Replace	Replace	

020107

S-7 Exhaust gas is black (incomplete combustion)

General causes why exhaust gas is black

- Insufficient intake of air
- Improper condition of fuel injection
- Excessive injection of fuel

		Causes															
		Clogged air cleaner element	Worn piston ring, cylinder	Clogged, seized injection nozzle	Improper injection timing	Defective injection pump	Improper valve clearance	Crushed, clogged muffler	Defective contact of valve, valve seat	Defective injection pump (rack, plunger seized)							
Question	Confirm recent repair history																
	Degree of use	Operated for long period	△	△	△											△	
		Suddenly became black															○
	Color of exhaust gas	Gradually became black	◎		○												
		Blue under light load															
	Engine oil must be added more frequently			◎													
	Power was lost	Suddenly				○					○					○	
		Gradually	○	○								○					
	Non-specified fuel has been used				○											○	
	Dust indicator is red		◎														
	Blow-by gas is excessive			◎													
	Engine pickup is poor and combustion is irregular				◎				○	○						○	
	When exhaust manifold is touched immediately after starting engine, temperature of some cylinders is low				◎											○	
	Match marks on fuel injection pump are out of alignment					◎											
	Seal on injection pump has come off						◎										
Clanging sound is heard from around cylinder head							◎										
Exhaust noise is abnormal				○						◎							
Muffler is crushed										◎							
Troubleshooting	When air cleaner is inspected directly, it is found to be clogged	●															
	When compression pressure is measured, it is found to be low		●												●		
	Speed of some cylinders does not change when operating on reduced cylinders			●													
	When check is made using delivery method, injection timing is found to be incorrect				●												
	Injection pump test shows that injection amount is incorrect					●											
	When valve clearance is checked directly it is found to be outside standard value						●										
	When muffler is removed, exhaust gas color returns to normal										●						
	When control rack is pushed, it is found to be heavy or does not return											●					
Remedy	Clean	Replace	Replace	Adjust	Adjust	Adjust	Replace	Replace	Replace								

020107

TROUBLESHOOTING OF HYDRAULIC AND MECHANICAL SYSTEM (H MODE)

Troubleshooting flow charts for each failure mode

All work equipment, travel, swing

H-1	Speeds of all work equipments, swing and travel are slow or lack of power	20-402
H-2	Excessive drop in engine speed, or engine stalls	20-404
H-3	All work equipment, travel and swing do not move	20-405
H-4	Abnormal sound is generated (around the pump)	20-405
H-5	Fine control ability is poor, or response is poor	20-406

Work equipment

H-6	Boom movement is slow or lacks of power	20-406
H-7	Arm movement is slow or lacks of power	20-408
H-8	Bucket movement is slow or lacks of power	20-410
H-9	Work equipment (boom, arm, bucket) does not move (but travel and swing are normal)	20-411
H-10	Excessive hydraulic drift (boom, arm, bucket)	20-411
H-11	Excessive time lag (engine at low speed)	20-412

Compound operations

H-12	In compound operations, work equipments, movement of one with larger load is slow	20-412
H-13	In swing + boom RAISE operation, boom RAISE movement is slow	20-413
H-14	In travel + swing operation, travel speed drop is excessive	20-413
H-15	In travel + work equipment (boom RAISE) operation, travel speed drop is excessive	20-413

Travel system

H-16	Vehicle curves unintentionally during travel	20-414
H-17	Travel deviation is larger at starting	20-416
H-18	Travel speed is low, or lacks of power	20-416
H-19	Steering operation is difficult	20-417
H-20	Travel speed cannot be switched	20-418
H-21	Travel does not work (one side only)	20-418

Swing system

H-22	Does not swing (both sides, one side only)	20-419
H-23	Swing acceleration is poor	20-420
H-24	Excessive overrun when stopping swing (both sides, one side only)	20-422
H-25	Excessive shock when stopping swing (one direction only)	20-423
H-26	Excessive abnormal noise when stopping swing (one direction only)	20-423
H-27	Excessive hydraulic drift of swing (when the swing brake is released or activated)	20-424
H-28	Swing speed is faster than the specified speed	20-425
H-29	Blade speed is slow, or lack of power	20-425
H-30	Blade does not move	20-426
H-31	Excessive hydraulic drift of the blade	20-426

020107

H-9 Work equipment (boom, arm, bucket) does not move (but travel and swing are normal)

★ When the boom, arm or bucket is operated independently.

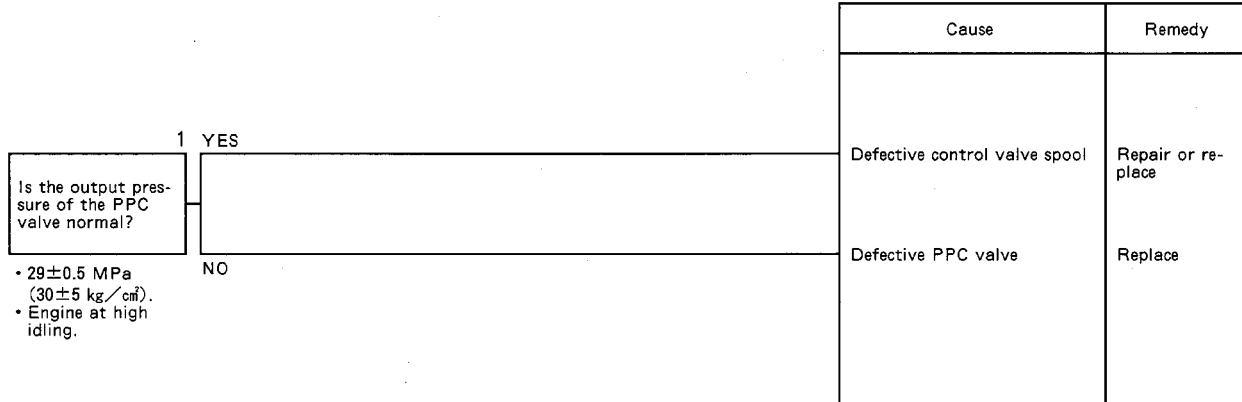

H-10 Excessive hydraulic drift (boom, arm, bucket)

※ Because the safety valve and the suction valve commonly serve for the boom, arm and bucket, if excessive hydraulic drift occurs equally for boom, arm and bucket, it can be judged that the cause is defective safety valve or suction valve.

020107

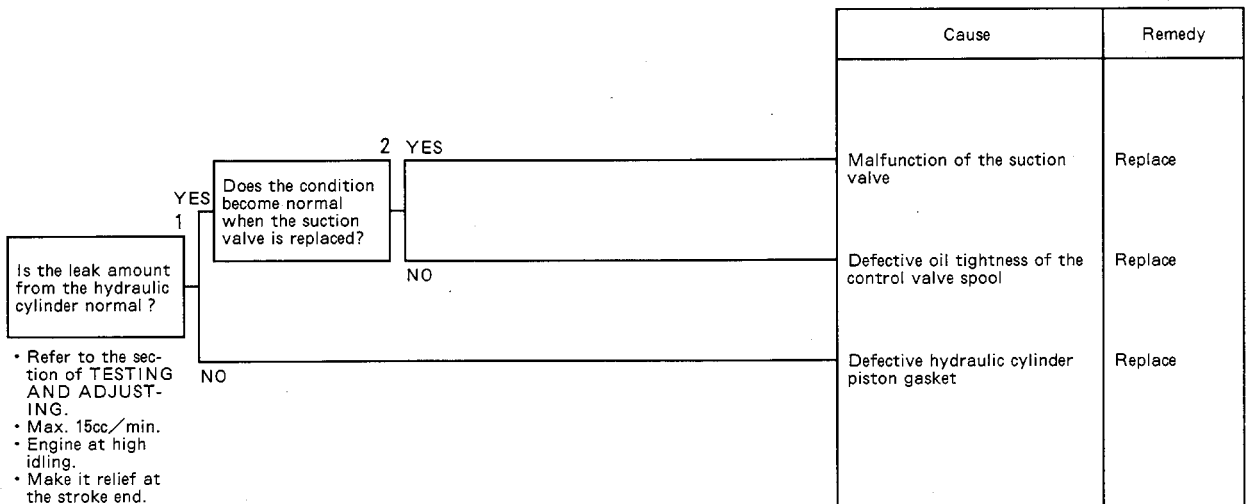

020107

Cause	Remedy
Defective swing motor assembly	Repair or replace
Defective pressure compensation valve	Replace
Defective swing motor safety valve	Replace
Defective swing motor suction valve	Replace
Malfunction of the control valve spool	Repair or replace
Malfunction of the PPC shuttle valve (for swing)	Repair or replace
Defective PPC valve	Replace

M-4 When turning ON the power (before engine starting), charge caution lamp does not light up

- ★ Before carrying out this troubleshooting, check for engagement failure at relating connectors.
- ★ Before proceeding to the next step, make sure to restore removed connectors.
- ★ Check for the breaking wire in the bulb (lamp) before this troubleshooting.

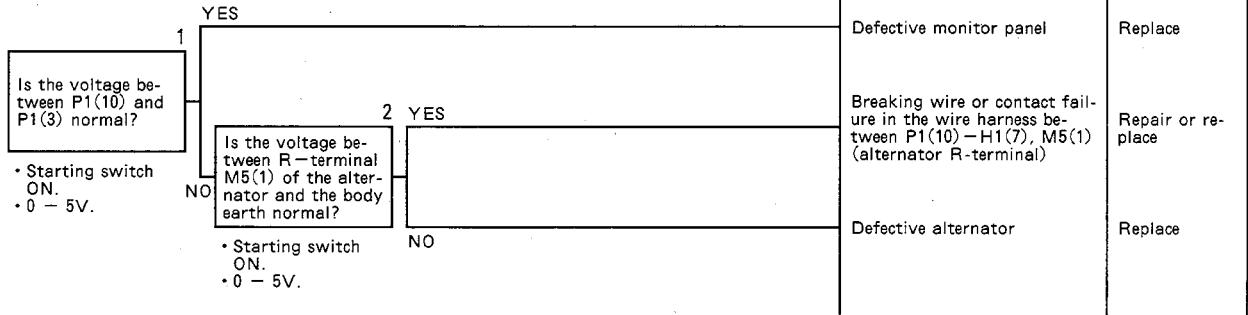

M-4 Related electrical circuit

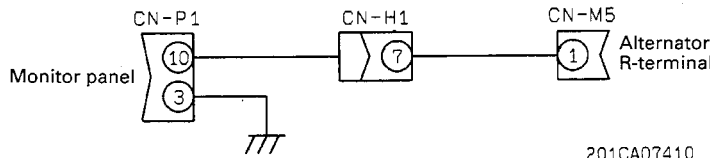

020107

M-5 When turning ON the power (before engine starting), engine oil pressure caution lamp does not light up.

- ★ Before carrying out this troubleshooting, check for engagement failure at relating connectors.
- ★ Before proceeding to the next step, make sure to restore removed connectors.
- ★ Check for the breaking wire in the bulb (lamp) before this troubleshooting.

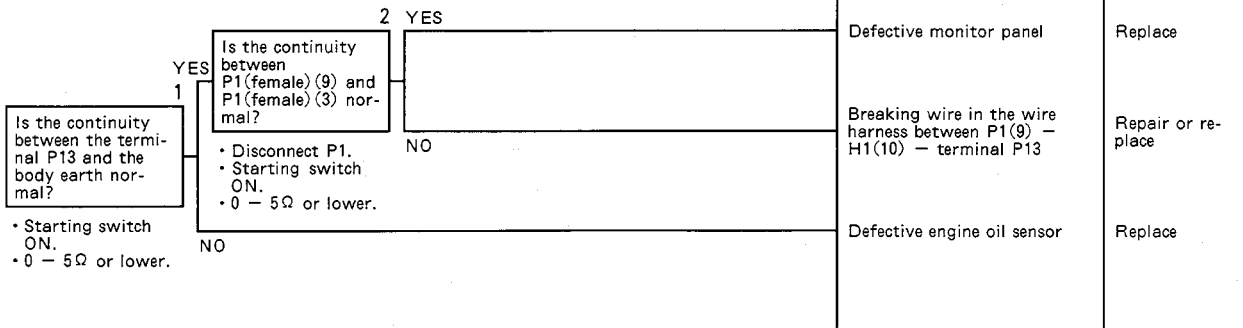

M-5 Related electrical circuit diagram

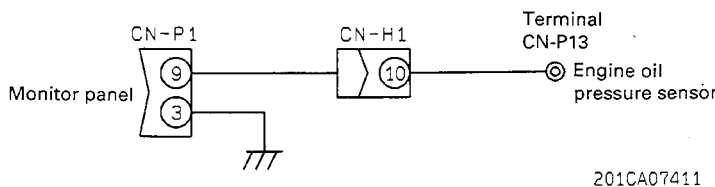

TROUBLESHOOTING OF AUTO-GREASING SYSTEM (D MODE)

D-1	[Alternate blinking of [E] and [a]] Abnormality in pump pressurization is displayed	20-502
D-2	[Alternate blinking of [E] and [b]] Abnormality in depressurization is displayed. [Alternate blinking of [E] and [c]] Abnormality in pressure detection is displayed.	20-504
D-3	[Alternate blinking of [E] and [0]] Abnormality in controller setting is displayed	20-504
D-4	Abnormal sound is generated from the work equipment pin, though no abnormality is displayed on the monitor panel and greasing controller.	20-506
D-5	All LEDs on the greasing controller goes off	20-508
D-6	Pump does not run even though the start-up switch is pressed.	20-508



020107

METHOD OF USING MANUAL

1. When removing or installing unit assemblies

- (1) When removing or installing a unit assembly, the order of work and techniques used are given for the removal operation; the order of work for the installation operation is not given.
- (2) Any special techniques applying only to the installation procedure are marked ※1, and the same mark is placed after the relevant step in the removal procedure to indicate which step in the installation procedure it applies to.

(Example)

REMOVAL OF ○○○ ASSEMBLY	Title of operation
	Precautions related to safety when carrying out the operation
1. XXX (1)	Step in operation
★	Technique or important point to remember when removing XXXX (1).
2. △△△ (2)	※1 Indicates that a technique is listed for use during installation
3. □□□□ assembly (3)	
	See Lubricant and Coolant Table

INSTALLATION OF ○○○ ASSEMBLY	Title of operation
• Carry out installation in the reverse order to removal.	
※1	Technique used during installation
★	Technique or important point to remember when installing △△△ (2).
• Adding water, oil	Step in operation
★	Point to remember when adding water or oil

2. General precautions when carrying out installation or removal (disassembly or assembly) of units are given together as PRECAUTIONS WHEN CARRYING OUT OPERATION, so be sure to follow these precautions when carrying out the operation.

3. Listing of special tools

- (1) For details of the description, part number, and quantity of any tools (A1, etc.) that appear in the operation procedure, see the SPECIAL TOOLS LIST given in this manual.
- (2) The items marked ☆ in the SPECIAL TOOL LIST are not supplied as an assembly.
- (3) Items listed as 79○T-○○○-○○○○ in the SPECIAL TOOL LIST are tools prohibited for supply.
- (4) The items marked  in the Sketch Column of the SPECIAL TOOL LIST are special tools with sketches introduced in this Shop Manual, but Komatsu cannot accept any responsibility for special tools manufactured according to the sketch.

020107

REMOVAL OF ALTERNATOR ASSEMBLY

⚠ Disconnect the cable from the negative (-) terminal of the battery.

1. Open engine hood and remove fan guard (1).
2. Disconnect blade pump outlet tube (2).
(Blade specification machine only)
3. Disconnect wiring (3).
4. Loosen adjustment plate mounting bolts and mount bolts (4).
5. Loosen tension adjustment bolt (5) and remove belt (6).
6. Remove adjustment plate mounting bolts and mount bolt (4), then remove alternator assembly (7).

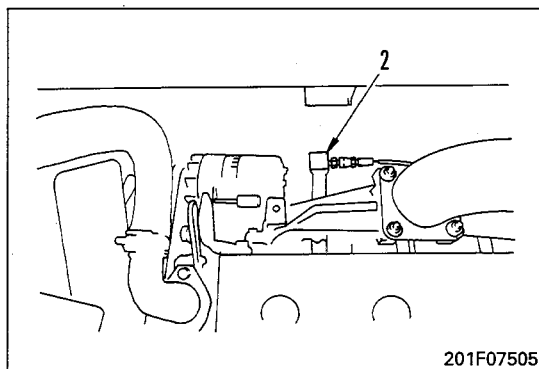
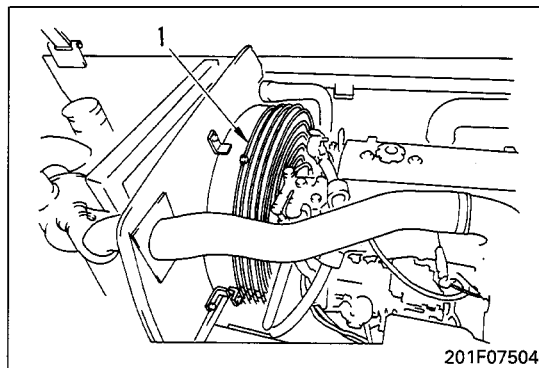

INSTALLATION OF ALTERNATOR ASSEMBLY

- Carry out installation in the reverse order to removal.
- ★ Adjust the belt tension.
For details, see TESTING AND ADJUSTING, Testing and adjusting of fan belt tension.

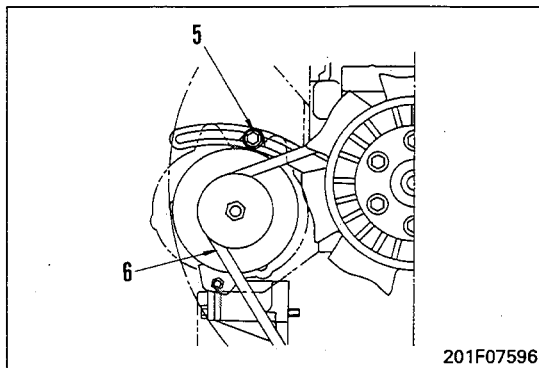
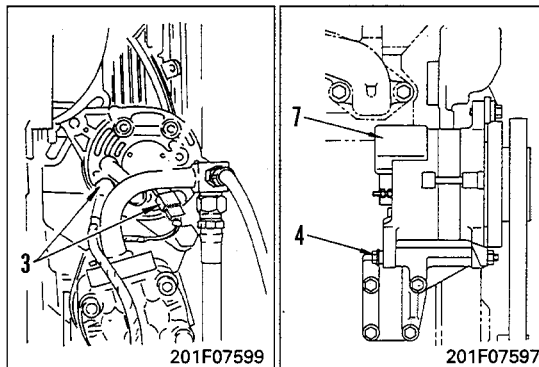

020107

INSTALLATION OF CYLINDER HEAD ASSEMBLY

- Carry out installation in the reverse order to removal.

※1

 kgm Hose clamp :
5.88±0.49 Nm (0.60±0.05 kgm)

※2

 kgm Sleeve nut :
22.1±2.5 Nm (2.25±0.25 kgm)

※3

 kgm Nozzle holder mounting bolt :
44.1±4.9 Nm (4.5±0.5 kgm)

※4

 kgm Head cover mounting bolt :
8.8±0.98 Nm (0.9±0.1 kgm)

※5

- ★ Clean the mounting bolt oil hole before installing.
- ★ Check that the ball of the adjustment screw is fitted securely in the socket of the push rod.
- ★ Adjust the valve clearance.
For details, see TESTING AND ADJUSTING, Adjusting valve clearance.

 kgm Rocker arm assembly mounting bolt :
24.5±4.9 Nm (2.5±0.5 kgm)

 kgm Locknut :
44.1±4.9 Nm (4.5±0.5 kgm) 30-26

020107

020107

11. Disconnect hydraulic cooler inlet hose (9) and outlet hose (10).
12. Remove guard (11).
13. Sling radiator and hydraulic cooler assembly (12), remove 2 bottom mounting bolts and 2 left and right isolators, then remove assembly.
 - ★ After raising towards the counterweight, turn at an angle and lift up.
 - ★ When lifting the radiator and hydraulic cooler assembly, be extremely careful not to damage the core.

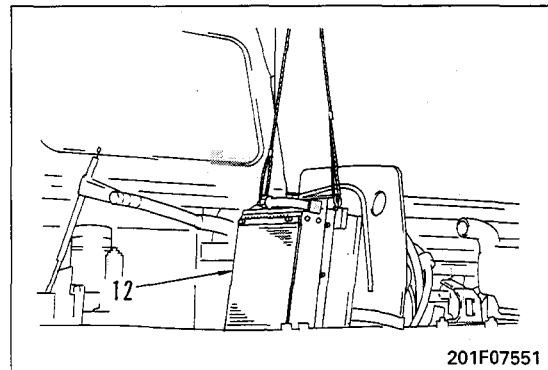
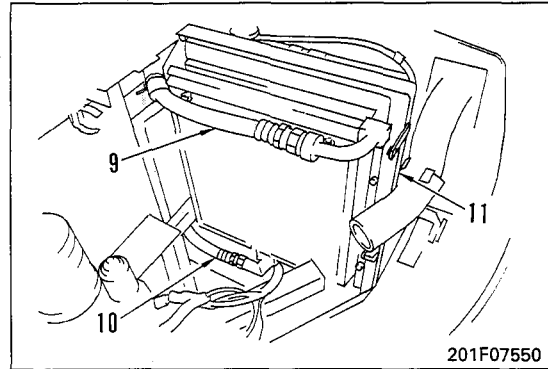

INSTALLATION OF RADIATOR • HYDRAULIC COOLER ASSEMBLY

- Carry out installation in the reverse order to removal.
- Refilling with water
 - ★ Add water through the water filler to the specified level. Run the engine to circulate the water through the system. Then check the water level again.
- Refilling with oil (hydraulic tank)
 - ★ Add oil through the oil filler to the specified level. Run the engine to circulate the oil through the system. Then check the oil level again.

- 3) Set shaft assembly to press, and using push tool ③, remove bearing (29) and collar (30) from shaft (31).

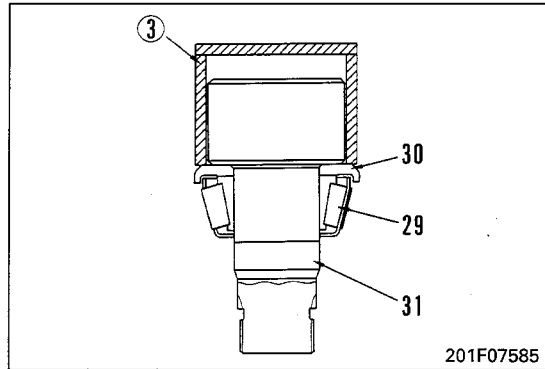

9. Dust seal, oil seal, bearing outer race

- 1) Remove dust seal (32) and oil seal (33) from case (34).

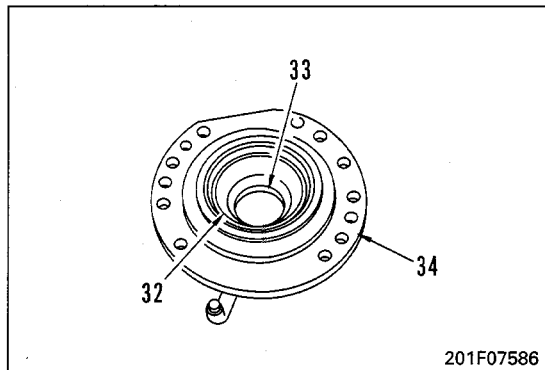

- 2) Using puller ④, remove bearing outer races (35) and (36) from case (34).

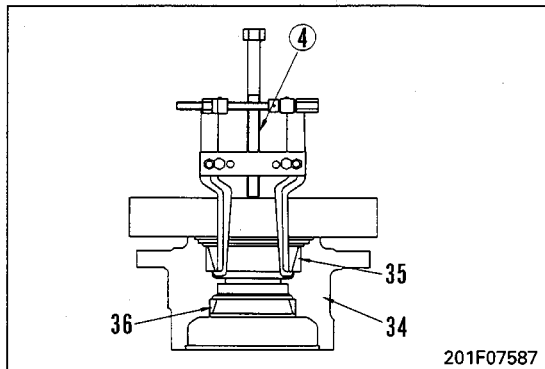

020107

DISASSEMBLY OF IDLER ASSEMBLY

1. Remove dowel pin (1), then remove support (2).
2. Remove floating seal (3) from support (2) and idler (4).
3. Pull out idler (4) from shaft (5) and support (7) assembly.
 - ★ It is filled with 60 cc. of oil, so drain the oil at this point or lay a cloth to prevent the area from becoming dirty.
4. Remove floating seal (6) on opposite side from idler (4) and shaft (5) and support (7) assembly.
5. Remove dowel pin (8), then remove support (7) from shaft (5).
6. Remove bushings (9) and (10) from idler (4).

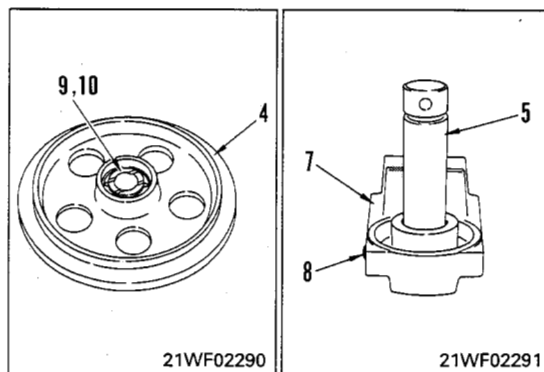
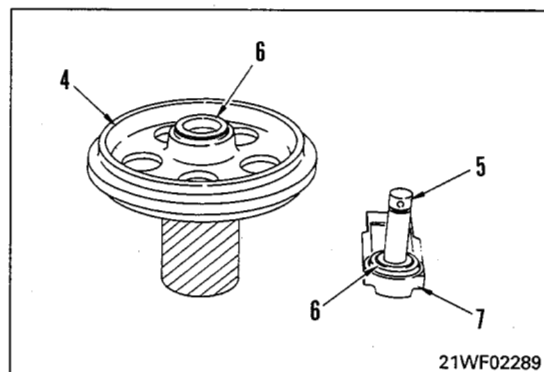
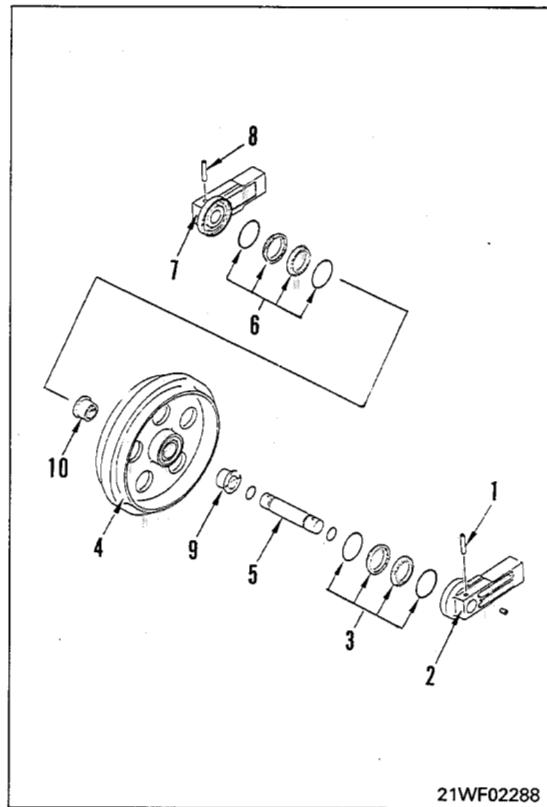

020107

REMOVAL OF CONTROL PUMP ASSEMBLY

! Lower the work equipment completely to the ground and stop the engine. Then loosen the oil filler cap slowly to release the pressure inside the hydraulic tank.

1. Remove the hydraulic tank strainer, and using tool **D1**, stop the oil.
 - ★ When not using tool **D1**, remove the drain plug, and drain the oil from the hydraulic tank and inside the system.



Hydraulic tank : Approx. 65 ℓ

2. Remove undercover under pump.
3. Disconnect control pump inlet tube (1).
4. Disconnect control pump outlet hose (2).
5. Disconnect power mode selector hose (3).
6. Remove control pump assembly (4), then remove coupling (5). ※1

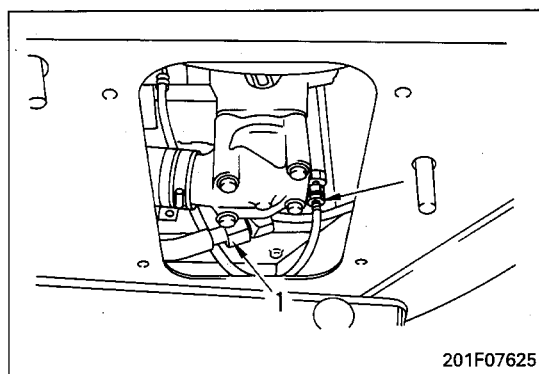
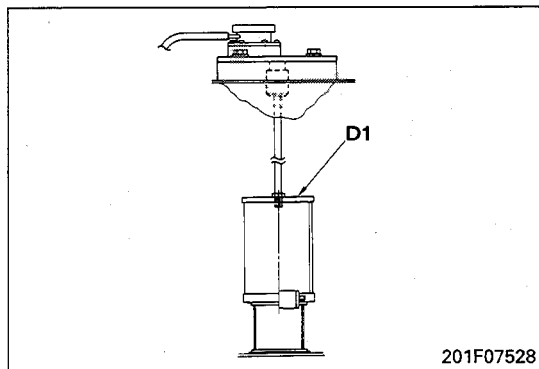

INSTALLATION OF CONTROL PUMP ASSEMBLY

- Carry out installation in the reverse order to removal.

※1

Control pump mounting bolt :
66.2±7.4 Nm (6.75±0.75 kgm)

- Refilling with oil (hydraulic tank)
 - ★ Add oil through the oil filler to the specified level.
 - Run the engine to circulate the oil through the system. Then check the oil level again.

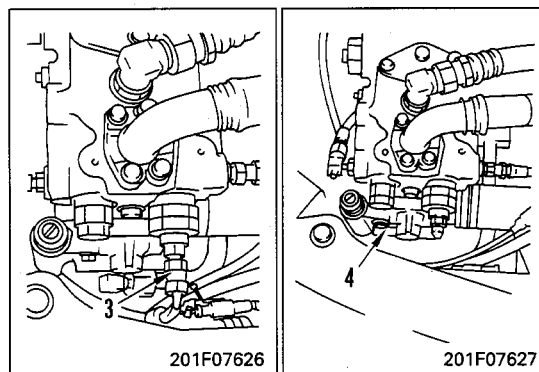

020107

020107

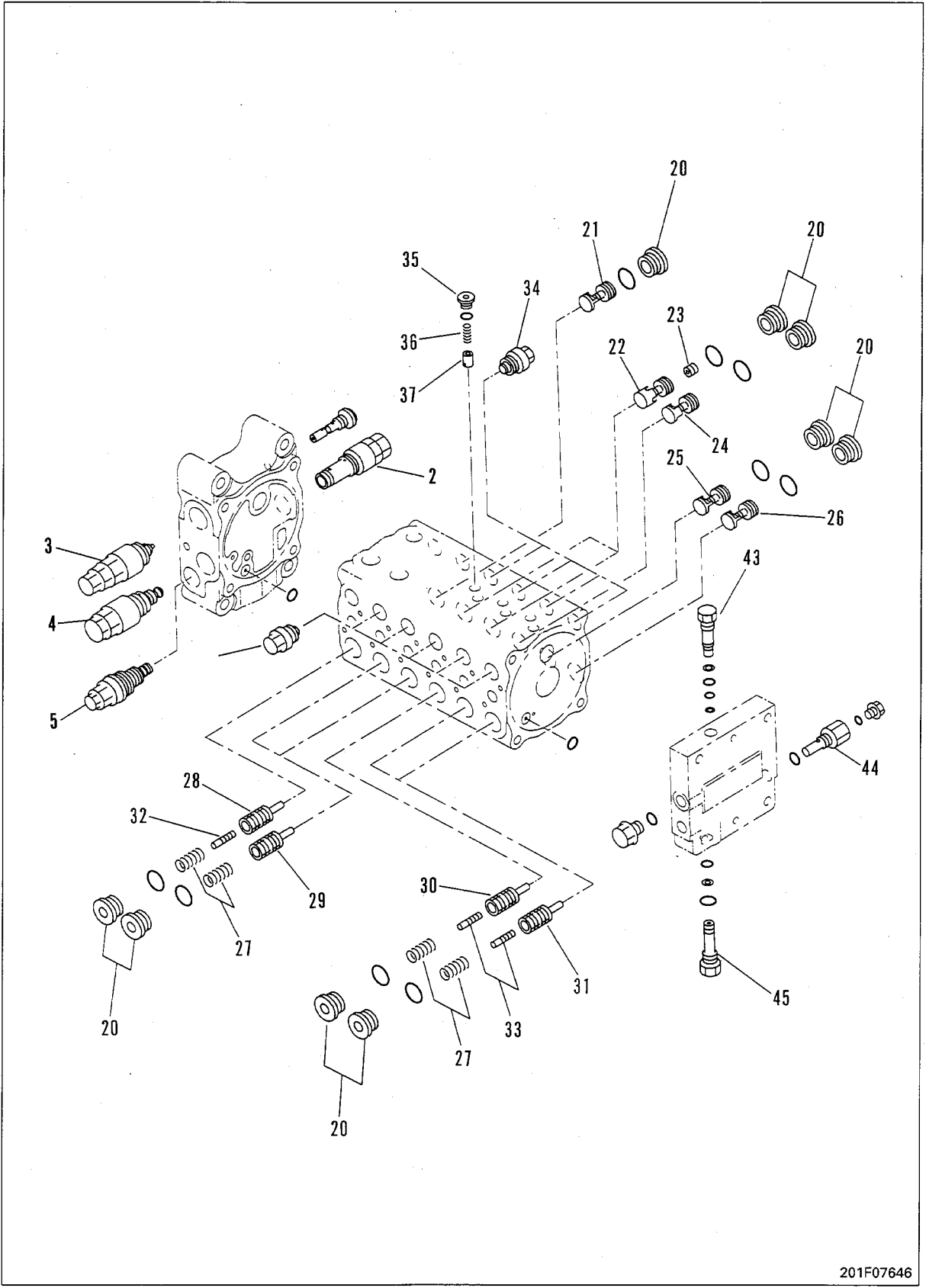

201F07646

REMOVAL OF SOLENOID VALVE ASSEMBLY

⚠ Disconnect the cable from the negative (-) terminal of the battery.

1. Open engine hood.
2. Remove 4 solenoid wiring connectors (1) from clip, then disconnect. ※1
3. Disconnect 8 hoses (2).
 - ★ Mark the connecting position of the hoses with tags before disconnecting.
4. Remove mounting bolts, then remove solenoid valve assembly (3).

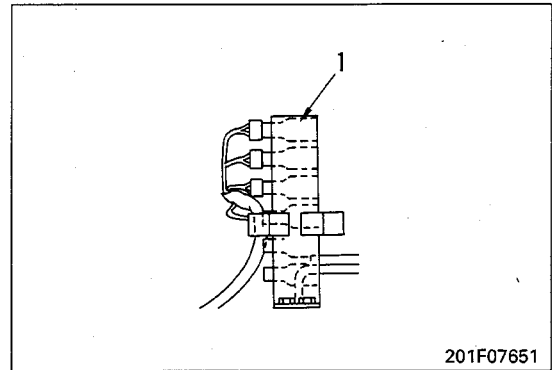

When removing solenoid valve as individual part
Remove nut (5), then remove solenoid valve (6).

※2

INSTALLATION OF SOLENOID VALVE ASSEMBLY

- Carry out installation in the reverse order to removal.

※1

Check the connector number, then connect.

※2

kgm Mounting nut (5) :
 $4.9 \pm 0.1 \text{ Nm}$ ($0.5 \pm 0.1 \text{ kgm}$)

kgm Solenoid valve as individual part (6) :
 $39.2 \pm 9.8 \text{ Nm}$ ($4 \pm 1 \text{ kgm}$)

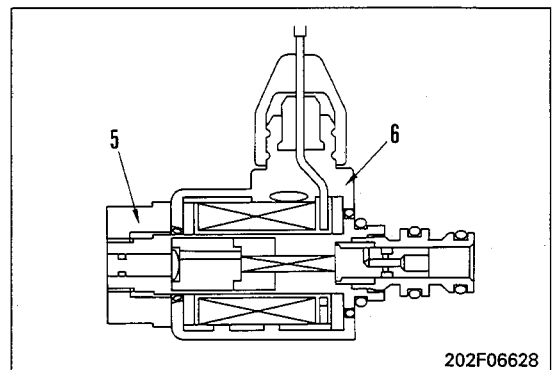
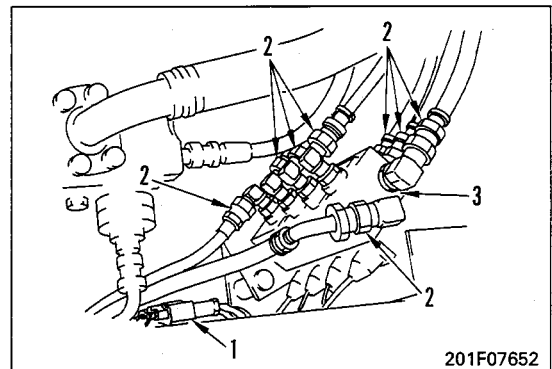

020107

REMOVAL OF ARM CYLINDER ASSEMBLY

! Curl the bucket and arm in, lower them onto a block, then set the safety lock to the LOCK position.

1. Sling arm cylinder assembly.
2. Disconnect grease tube (1).
3. Remove lock plate, then remove head pin (2).

※1

★ There are shims installed, so check the number and thickness, and keep in a safe place.

4. Start engine, and retract piston rod, then tie piston rod with wire to prevent it from coming out.

! An accumulator is installed, so loosen the sleeve nut of the hose slowly and check that no oil spurts out before removing.

5. Disconnect left and right hoses (3).
6. Disconnect grease tube (4).
7. Raise arm cylinder assembly, remove plate, then remove bottom pin (5), and remove arm cylinder assembly (6).

※2

★ There are shims installed, so check the number and thickness, and keep in a safe place.

 Arm cylinder assembly : 80 kg

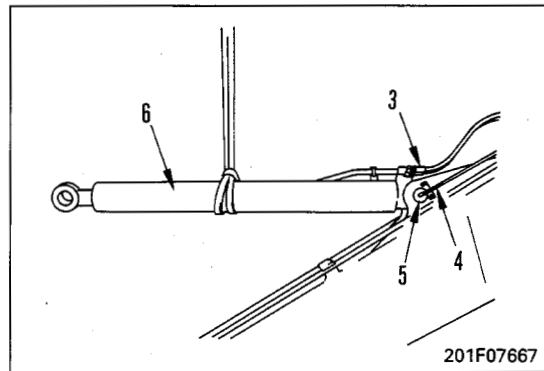
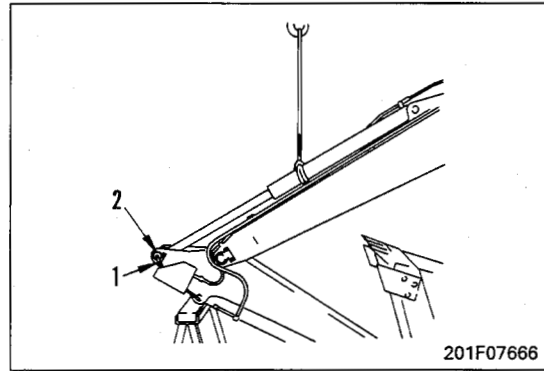

020107

3) Using hydraulic pump or power wrench, tighten head assembly (2) with tool E2.

 Head assembly :

Cylinder	Tightening torque
Boom	961.1±96.7 Nm (98±9.8 kgm)
Arm	784.6±78.5 Nm (80±8 kgm)
Bucket	814.0±81.9 Nm (83±8.3 kgm)
Blade	1029.7±103.6 Nm (105±10.5 kgm)

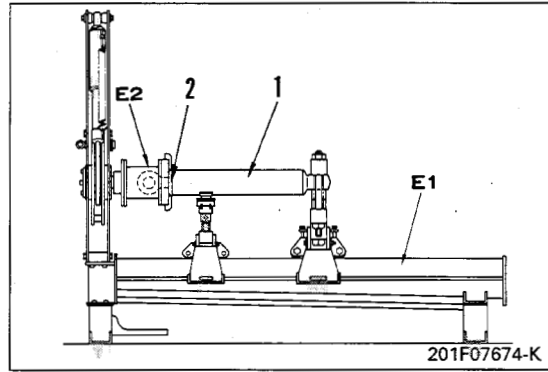



020107

INSTALLATION OF BOOM ASSEMBLY

- Carry out installation in the reverse order to removal.

※1

 Inside surface of bushing when assembling pin : Anti-friction compound (LM-P)

 Grease after assembling pin :
Grease (LM-G)

-  When aligning the position of the pin hole, never insert your fingers in the pin hole.
- ★ Adjust the shim thickness so that the clearance between cylinder rod (10) and bracket (11) is below 1 mm.
- ★ Standard shim thickness : 1.0 mm

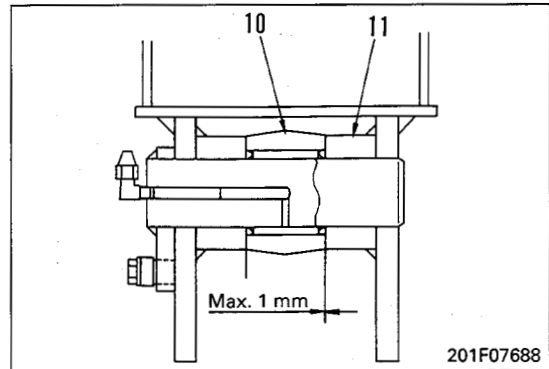

※2

 Inside surface of bushing when assembling pin : Anti-friction compound (LM-P)

 Grease after assembling pin :
Grease (LM-G)

-  When aligning the position of the pin hole, never insert your fingers in the pin hole.
- ★ Adjust the shim thickness so that the clearance between boom (12) and bracket (13) is below 1 mm.
- ★ Standard shim thickness :
0.5 mm, 1.0 mm

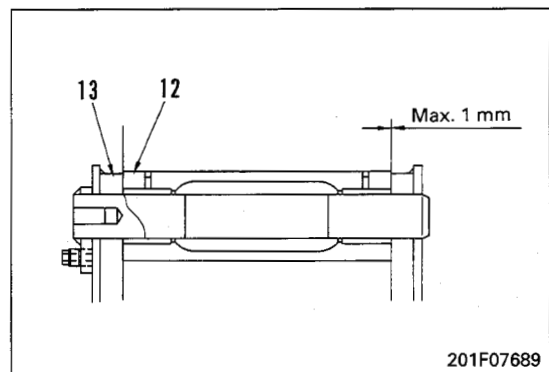

020107

- Refilling with oil (hydraulic tank)
 - ★ Add oil through the oil filler to the specified level.
Run the engine to circulate the oil through the system. Then check the oil level again.
- Bleeding air
 - ★ Bleed the air from the cylinder.
For details, see TESTING AND ADJUSTING, Bleeding air from hydraulic cylinder.

TRACK FRAME

★ Figure shows the machine equipped with iron shoes.

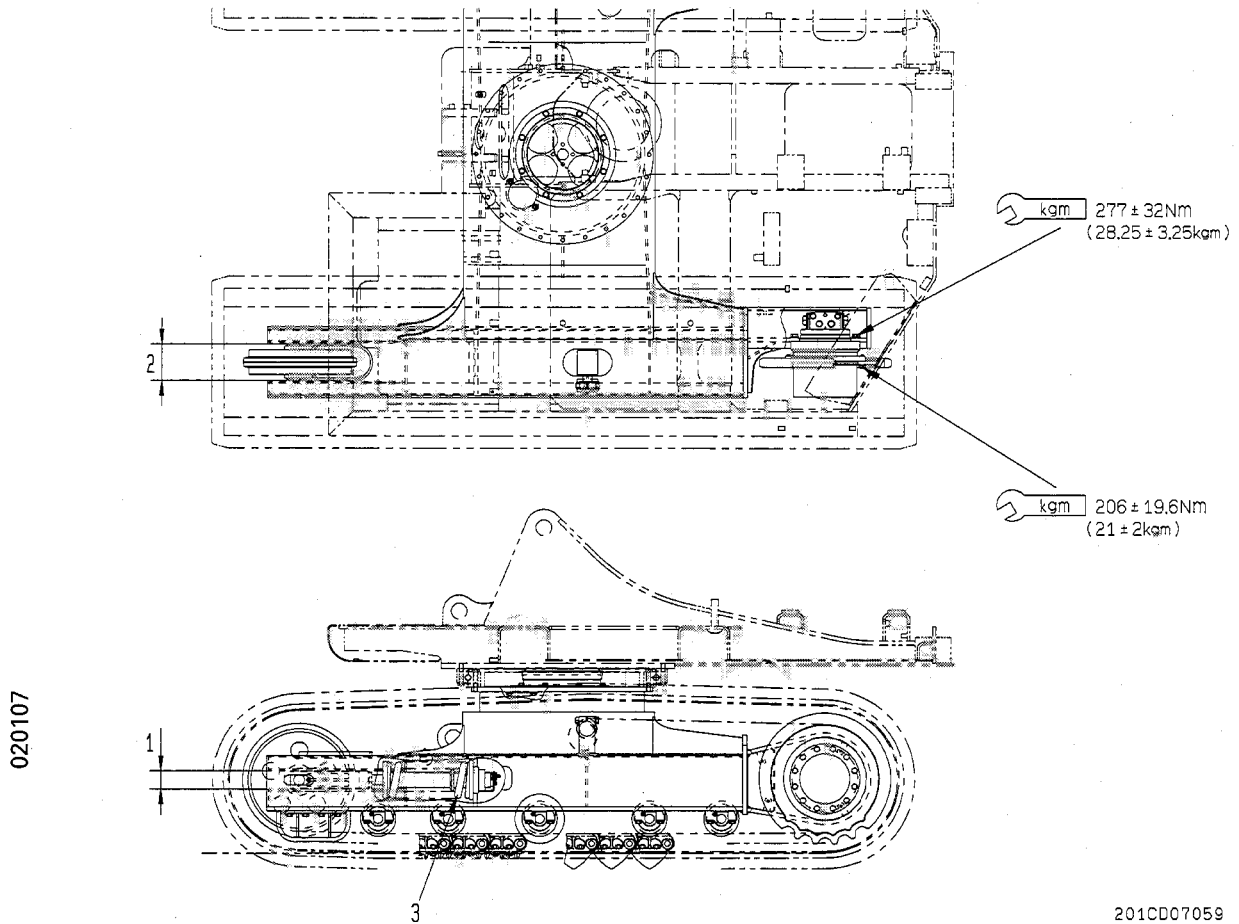

201CD07059

Unit: mm

No.	Check item	Criteria				Remedy	
		Standard size		Repair limit			
1	Vertical width of idler guide	Track frame	74	78	Rebuild		
		Idler	73	69	Rebuild or replace		
2	Horizontal width of idler guide	Track frame	158	162	Rebuild		
		Idler	156	152	Rebuild or replace		
3	Recoil spring	Standard size		Repair limit		Replace	
		Free length	Installed length	Installed load	Free length		Installed load
		410	332	42.6 kN (4,350 kg)	400		37.9 kN (3,872 kg)

BLADE PUMP

BLADE TYPE MODELS

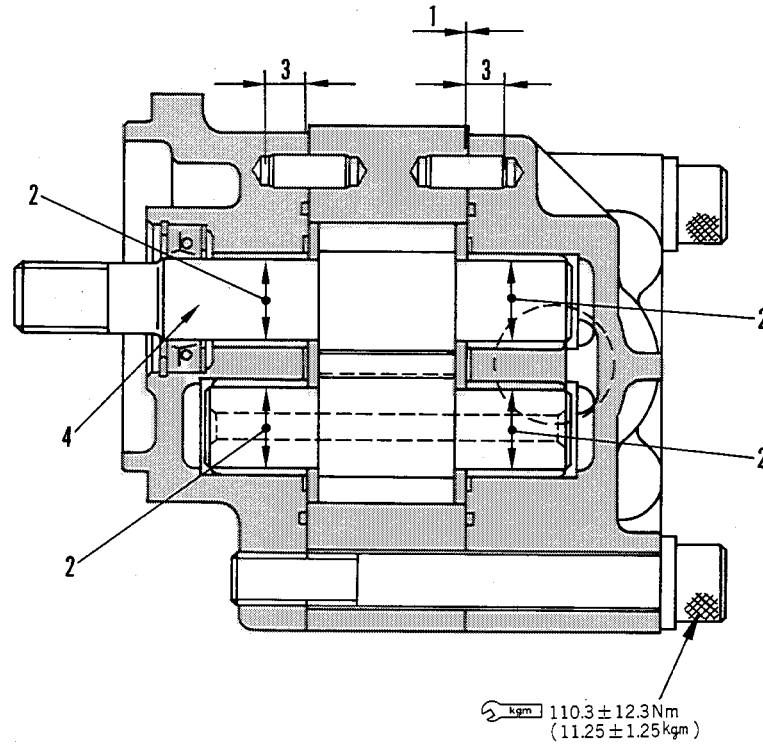

020107

202F06431A-K

Unit: mm

No.	Check item	Criteria				Remedy
		Standard clearance		Clearance limit		
1	Clearance between gear case and side plate	0.10 – 0.15		0.19		Replace
2	Clearance between gear shaft and bearing	0.060 – 0.119		0.20		
3	Pin insertion depth	$10 \begin{smallmatrix} 0 \\ -0.5 \end{smallmatrix}$				
4	Rotating torque of drive shaft	2.0 – 4.9 MPa (0.2 – 0.5 kgm)				
5	Delivery (SAE10W, 45 – 55°C)	Revolutions (rpm)	Discharge pressure	Standard value (ℓ/min)	Repair limit (ℓ/min)	—
		3,500	20.6 MPa (210 kg/cm ²)	67.6	62.4	

CENTER SWIVEL JOINT

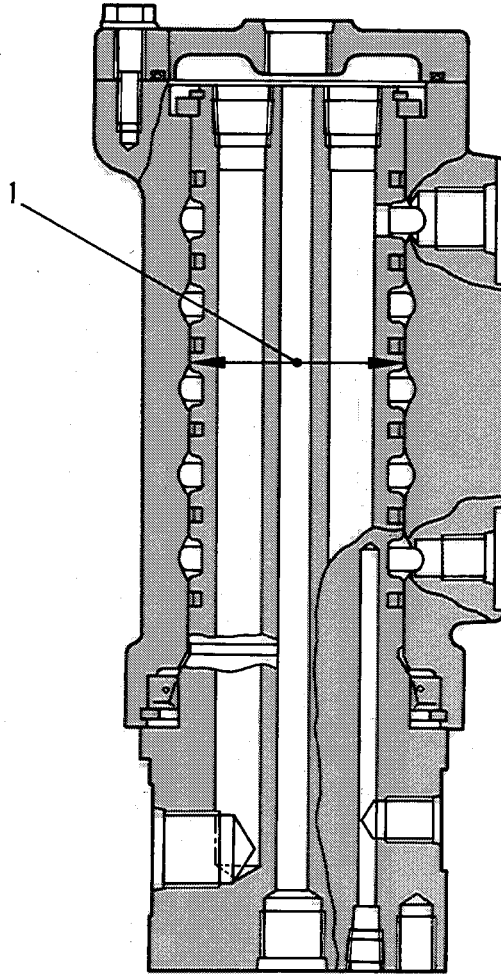

020107

F20106333

Unit: mm

No.	Check item	Criteria			Remedy
		Standard size	Standard clearance	Clearance limit	
1	Clearance between rotor and shaft	70	0.056 – 0.105	0.111	Replace

CLICK HERE TO **DOWNLOAD** THE COMPLETE MANUAL

- Thank you very much for reading the preview of the manual.
- You can download the complete manual from: www.heydownloads.com by clicking the link below



- Please note: If there is no response to CLICKING the link, please download this PDF first and then click on it.

CLICK HERE TO **DOWNLOAD** THE COMPLETE MANUAL