

SHOP

MANUAL

KOMATSU

PC450, 450LC-6K

MACHINE MODEL

SERIAL NUMBER

PC450-6K

K32001 and up

K34001 and up

PC450LC-6K

K32001 and up

K34001 and up

- This shop manual may contain attachments and optional equipment that are not available in your area. Please consult your local Komatsu distributor for those items you may require. Materials and specifications are subject to change without notice.
- PC450-6K mounts the SA6D125E-2 engine.
For details of the engine, see the 125-2 Series Engine Shop Manual.

CLICK HERE TO **DOWNLOAD** THE COMPLETE MANUAL

- Thank you very much for reading the preview of the manual.
- You can download the complete manual from: www.heydownloads.com by clicking the link below



- Please note: If there is no response to CLICKING the link, please download this PDF first and then click on it.

CLICK HERE TO **DOWNLOAD** THE COMPLETE MANUAL

HOISTING INSTRUCTIONS

HOISTING

! Heavy parts (25 kg or more) must be lifted with a hoist, etc. In the **DISASSEMBLY AND ASSEMBLY** section, every part weighing 25 kg or more is indicated clearly with the symbol 4

- If a part cannot be smoothly removed from the machine by hoisting, the following checks should be made:
 - 1) Check for removal of all bolts fastening the part to the relative parts.
 - 2) Check for existence of another part causing interference with the part to be removed.

WIRE ROPES

- 1) Use adequate ropes depending on the weight of parts to be hoisted, referring to the table below:

Wire ropes (Standard "Z" or "S" twist ropes without galvanizing)		
Rope diameter mm	Allowable load	
	kN	tons
10	9.8	1.0
11.2	13.7	1.4
12.5	15.7	1.6
14	21.6	2.2
16	27.5	2.8
18	35.3	3.6
20	43.1	4.4
22.4	54.9	5.6
30	98.1	10.0
40	176.5	18.0
50	274.6	28.0
60	392.2	40.0

★ The allowable load value is estimated to be one-sixth or one-seventh of the breaking strength of the rope used.

- 2) Sling wire ropes from the middle portion of the hook.

Slinging near the edge of the hook may cause the rope to slip off the hook during hoisting, and a serious accident can result. Hooks have maximum strength at the middle portion.

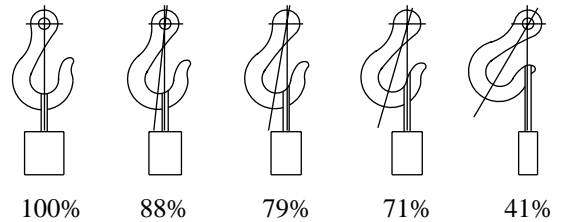

SAD00479

- 3) Do not sling a heavy load with one rope alone, but sling with two or more ropes symmetrically wound onto the load.

! Slinging with one rope may cause turning of the load during hoisting, untwisting of the rope, or slipping of the rope from its original winding position on the load, which can result in a dangerous accident.

- 4) Do not sling a heavy load with ropes forming a wide hanging angle from the hook. When hoisting a load with two or more ropes, the force subjected to each rope will increase with the hanging angles. The table below shows the variation of allowable load kN {kg} when hoisting is made with two ropes, each of which is allowed to sling up to 9.8 kN {1000 kg} vertically, at various hanging angles.

When two ropes sling a load vertically, up to 19.6 kN {2000 kg} of total weight can be suspended. This weight becomes 9.8 kN {1000 kg} when two ropes make a 120° hanging angle. On the other hand, two ropes are subjected to an excessive force as large as 39.2 kN {4000 kg} if they sling a 19.6 kN {2000 kg} load at a lifting angle of 150°.

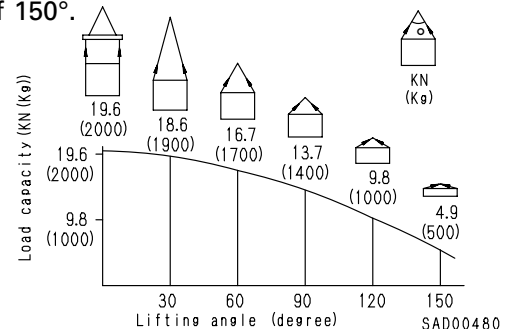

kgm to ft. lb

1 kgm = 7.233 ft. lb

	0	1	2	3	4	5	6	7	8	9
0	0	7.2	14.5	21.7	28.9	36.2	43.4	50.6	57.9	65.1
10	72.3	79.6	86.8	94.0	101.3	108.5	115.7	123.0	130.2	137.4
20	144.7	151.9	159.1	166.4	173.6	180.8	188.1	195.3	202.5	209.8
30	217.0	224.2	231.5	238.7	245.9	253.2	260.4	267.6	274.9	282.1
40	289.3	296.6	303.8	311.0	318.3	325.5	332.7	340.0	347.2	354.4
50	361.7	368.9	376.1	383.4	390.6	397.8	405.1	412.3	419.5	426.8
60	434.0	441.2	448.5	455.7	462.9	470.2	477.4	484.6	491.8	499.1
70	506.3	513.5	520.8	528.0	535.2	542.5	549.7	556.9	564.2	571.4
80	578.6	585.9	593.1	600.3	607.6	614.8	622.0	629.3	636.5	643.7
90	651.0	658.2	665.4	672.7	679.9	687.1	694.4	701.6	708.8	716.1
100	723.3	730.5	737.8	745.0	752.2	759.5	766.7	773.9	781.2	788.4
110	795.6	802.9	810.1	817.3	824.6	831.8	839.0	846.3	853.5	860.7
120	868.0	875.2	882.4	889.7	896.9	904.1	911.4	918.6	925.8	933.1
130	940.3	947.5	954.8	962.0	969.2	976.5	983.7	990.9	998.2	1005.4
140	1012.6	1019.9	1027.1	1034.3	1041.5	1048.8	1056.0	1063.2	1070.5	1077.7
150	1084.9	1092.2	1099.4	1106.6	1113.9	1121.1	1128.3	1135.6	1142.8	1150.0
160	1157.3	1164.5	1171.7	1179.0	1186.2	1193.4	1200.7	1207.9	1215.1	1222.4
170	1129.6	1236.8	1244.1	1251.3	1258.5	1265.8	1273.0	1280.1	1287.5	1294.7
180	1301.9	1309.2	1316.4	1323.6	1330.9	1338.1	1345.3	1352.6	1359.8	1367.0
190	1374.3	1381.5	1388.7	1396.0	1403.2	1410.4	1417.7	1424.9	1432.1	1439.4

WEIGHT TABLE

PC450, 450LC-6K

Unit: kg

Machine model	PC450-6K	PC450LC-6K
Serial number	K32001 and up	K32001 and up
Engine assembly	1,500	1,500
• Engine	1,160	1,160
• Damper	14.7	14.7
• Hydraulic pump	210	210
Radiator, oil cooler assembly	186	186
Hydraulic tank, filter assembly (excl. hydraulic oil)	254	254
Fuel tank (excl. fuel)	231	231
Revolving frame	3,135	3,135
Operator's cab	287	287
Operator's seat	29	29
Counterweight	8,890	8,890
Swing machinery	535	535
Control valve (standard)	256	256
Swing motor	82	82
Travel motor	252 x 2	252 x 2
Center swivel joint	37	37
Track frame assembly	10,895	11,040
• Track frame	6,604	6,604
• Swing circle	605	605
• Idler	235	235
• Idler cushion	365 x 2	365 x 2
• Carrier roller	31 x 4	31 x 4
• Track roller	73 x 14	73 x 16
• Final drive (incl. travel motor)	788 x 2	788 x 2

10 STRUCTURE AND FUNCTION

Parts related to engine	10- 2
Radiator, oil cooler	10- 4
Power train	10- 5
Final drive	10- 6
Swing circle	10- 7
Swing machinery	10- 8
Track frame, recoil spring	10- 9
Track shoe	10- 10
Hydraulic piping drawing	10- 12
Hydraulic circuit diagram	10- 14
Hydraulic tank, hydraulic filter	10- 16
Hydraulic pump	10- 17
Control valve	10- 38
Self-reducing pressure valve	10- 48
Suction safety valve	10- 53
CLSS	10- 55
Swing motor	10-120
Center swivel joint	10-126
Travel motor	10-128
Valve control	10-137
Work equipment • swing PPC valve	10-138
Travel PPC valve	10-142
Service PPC valve	10-146
PPC safety lock valve	10-149
PPC accumulator	10-149
PPC shuttle valve, travel junction valve ...	10-151
LS-EPC valve	10-158
Solenoid valve	10-162
Boom safety valve	10-164
Overload warning device	10-167
Work equipment	10-169
Air conditioner	10-170
Actual electric wiring diagram	10-171
Electric circuit diagram	10-175
Engine control	10-178
Electronic control system	10-185
Machine monitor system	10-212
Breaker mode hydraulic performance	10-223

Operation

1. Operation of pump

- Cylinder block (7) rotates together with shaft (1), and shoe (5) slides on flat surface **A**. When this happens, rocker cam (4) moves along cylindrical surface **B**, so angle α between center line **X** of rocker cam (4) and the axial direction of cylinder block (7) changes. (Angle α is called the swash plate angle.)

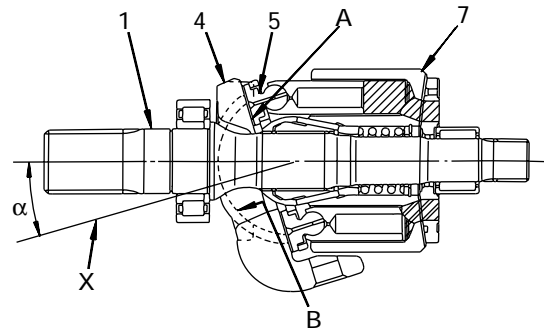

SLP00163

- 1) Center line **X** of rocker cam (4) maintains swash plate angle α in relation to the axial direction of cylinder block (7), and flat surface **A** moves as a cam in relation to shoe (5). In this way, piston (6) slides on the inside of cylinder block (7), so a difference between volume **E** and **F** is created inside cylinder block (7). The suction and discharge is equal to this difference **F - E**.

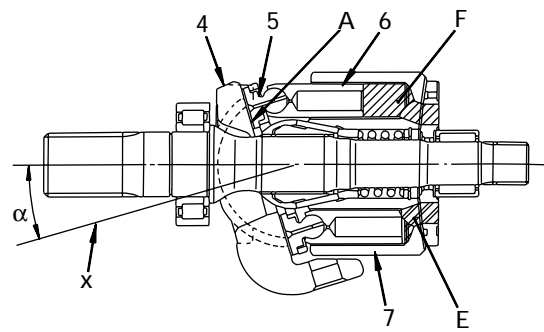

SLP00164

In other words, when cylinder block (7) rotates and the volume of chamber **E** becomes smaller, the oil is discharged during that stroke. On the other hand, the volume of chamber **F** becomes larger, and as the volume becomes bigger, the oil is sucked in.

- 2) If center line **X** of rocker cam (4) is in line with the axial direction of cylinder block (7) (swash plate angle = 0), the difference between volumes **E'** and **F'** inside cylinder block (7) becomes 0, so the pump does not carry out any suction or discharge of oil.

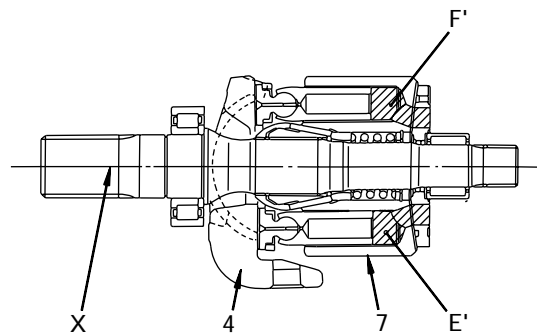

SLP00165

2. TVC valve

1) When governor, pump controller are normal

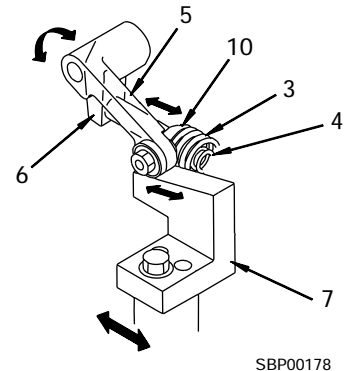
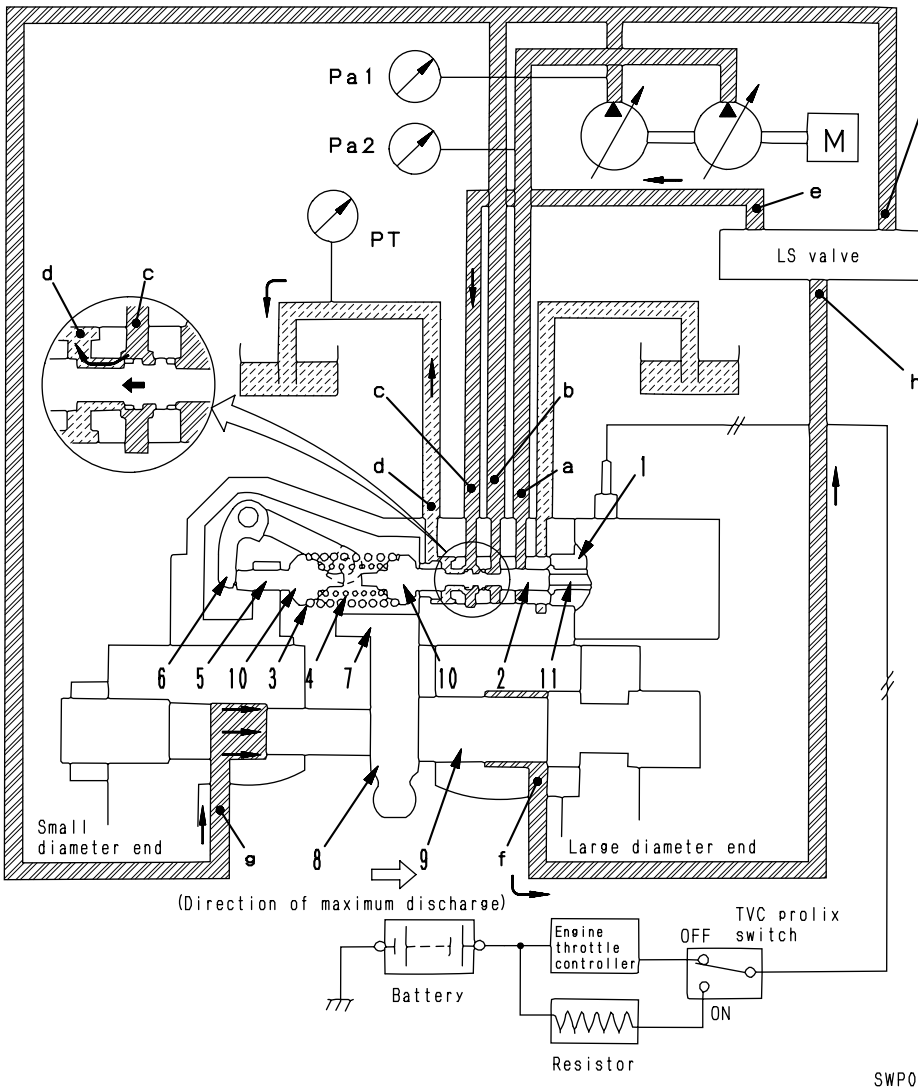

SBP00178

★ Other pump pressure
 This is the pressure of the pump at the opposite end.
 For the front pump, it is the rear pump pressure
 For the rear pump, it is the front pump pressure

SWP05080

a. When the load on the actuator is small and pump pressures Pa1 and Pa2 are low

- ① Action of solenoid (1)
 - Command current x from the governor, pump controller flows to solenoid (1). This command current changes the internal force pushing solenoid push pin (11).
 - On the opposite side to the force pushing this solenoid push pin (11) is the spring set pressure of springs (3) and (4) and pump pressure **Pa1** and other pump pressure **Pa2** (see ★). Piston (2) stops at a position where the combined force pushing piston (2) is bal-

- anced, and the pressure (pressure of port **c**) output from the TVC valve changes according to this position.
- The size of command current x is determined by the nature of the operation (lever operation), the selection of the working mode, and the set value and actual value for the engine speed.

(2/3)

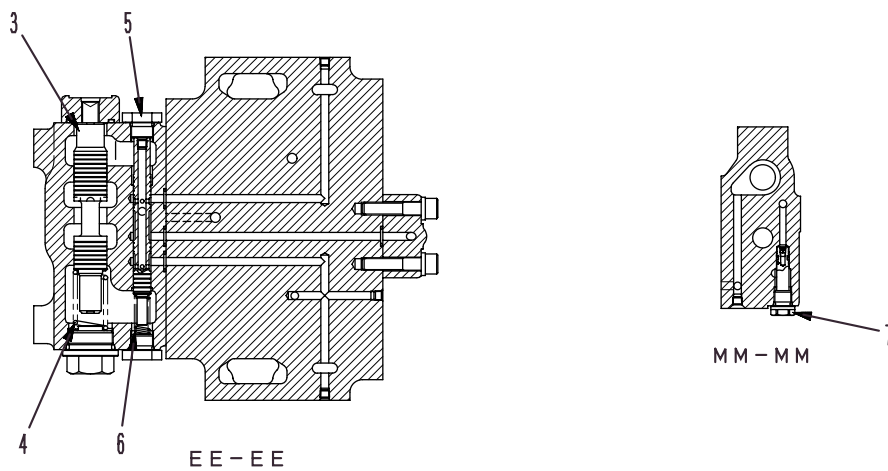
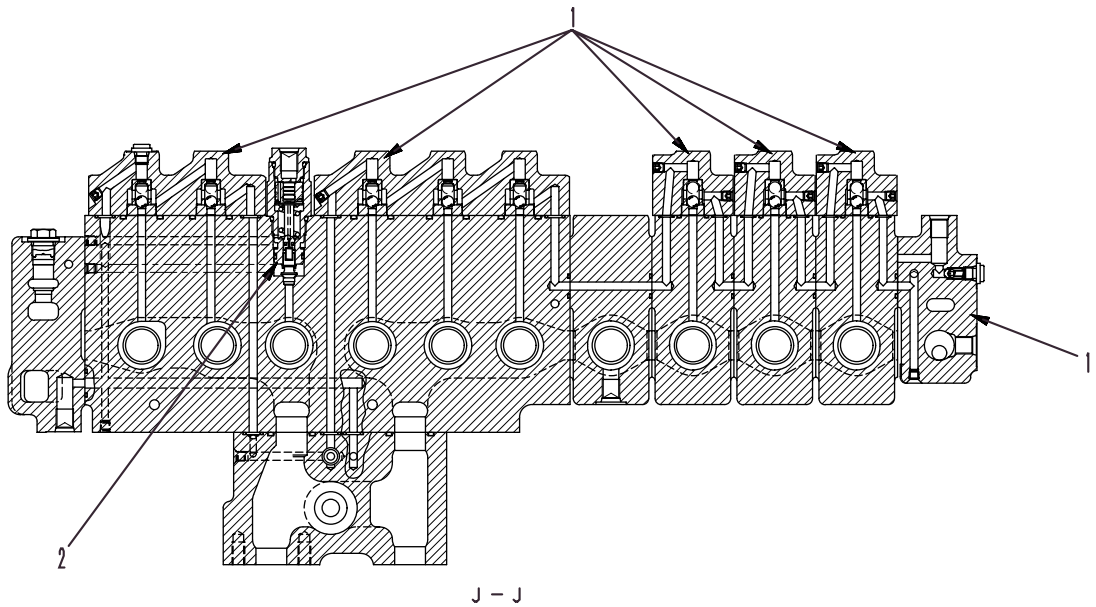

1. LS shuttle valve
2. LS divider valve
3. Merge/flow divider valve (main)
4. Return spring
5. Merge/flow divider valve (for LS)
6. Return spring
7. LS bypass valve

SWP05016

2. At neutral and

When load pressure **P2** is low (when moving down under own weight (boom LOWER or arm IN))

Note: When load pressure **P2** is lower than output pressure **PR** of the self-reducing pressure valve.

- Valve (2) receives force in the direction to close the passage from port **P1** → **P2** from spring (3) and pressure **PR** (when the engine is stopped, the pressure is 0 MPa {0 kg/cm²}). However, when hydraulic oil flows in from port **P1**, the pressure is balanced so that pressure **P1** ≅ force of spring (8) + (area $\phi d \times$ pressure **PR**), and the opening from port **P1** → **P2** is adjusted so that pressure **P1** is kept at a certain value above pressure **PR**.
- When pressure **PR** goes above the set pressure, poppet (5) opens, and the hydraulic oil flows in the following circuit: port **PR** → hole **a** inside spool (9) → opening of poppet (5) → tank port **T**.

As a result, a pressure difference is created on both sides of hole **a** inside spool (9), so spool (9) moves in the direction to close the opening from port **P1** → **PR**. Pressure **P1** is reduced to a certain pressure (set pressure) by the amount of opening at this point, and is supplied as pressure **PR**. (See Fig. 2)

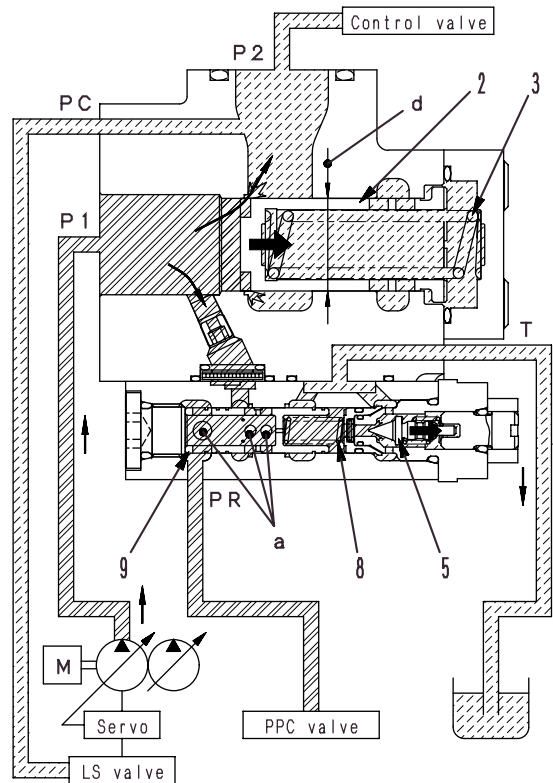

(Fig. 2)

SWP05089

3. When load pressure **P2** is high

If load pressure **P2** increases and the pump discharge amount also increases because of digging operations, pressure **P1** also increases (pressure **P1** > force of spring (8) + (area $\phi d \times$ pressure **PR**), so valve (2) moves to the right to the end of the stroke.

As a result, the amount of opening from port **P1** → **P2** increases and the resistance in the passage is reduced, so the loss of engine horsepower is reduced.

- If pressure **PR** goes above the set pressure, poppet (5) opens and the hydraulic oil flows in the following circuit: port **PR** → hole **a** inside spool (8) → opening of poppet (5) → tank port **T**.

As a result, a pressure difference is created on both sides of hole **a** inside spool (9), so spool (9) moves in the direction to close the opening from port **P1** → **PR**. Pressure **P1** is reduced to a certain pressure (set pressure) by the amount of opening at this point, and is supplied as pressure **PR**. (See Fig. 3)

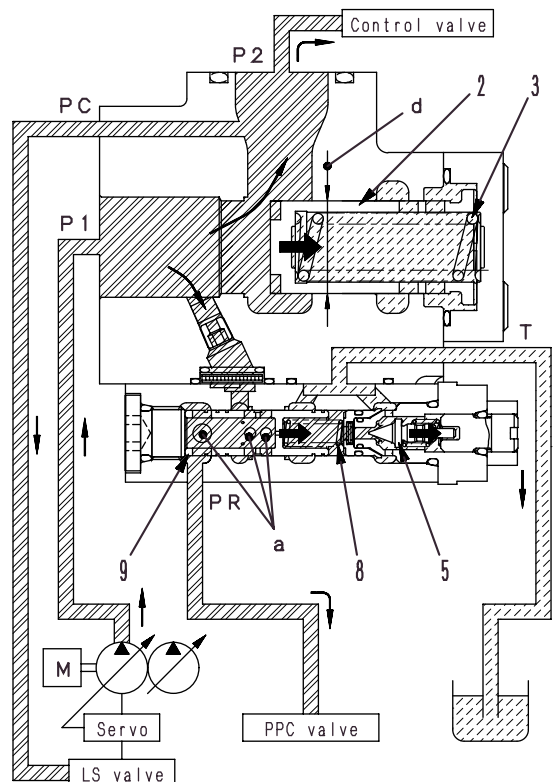

(Fig. 3)

SWP05090

1. When unload valve is actuated

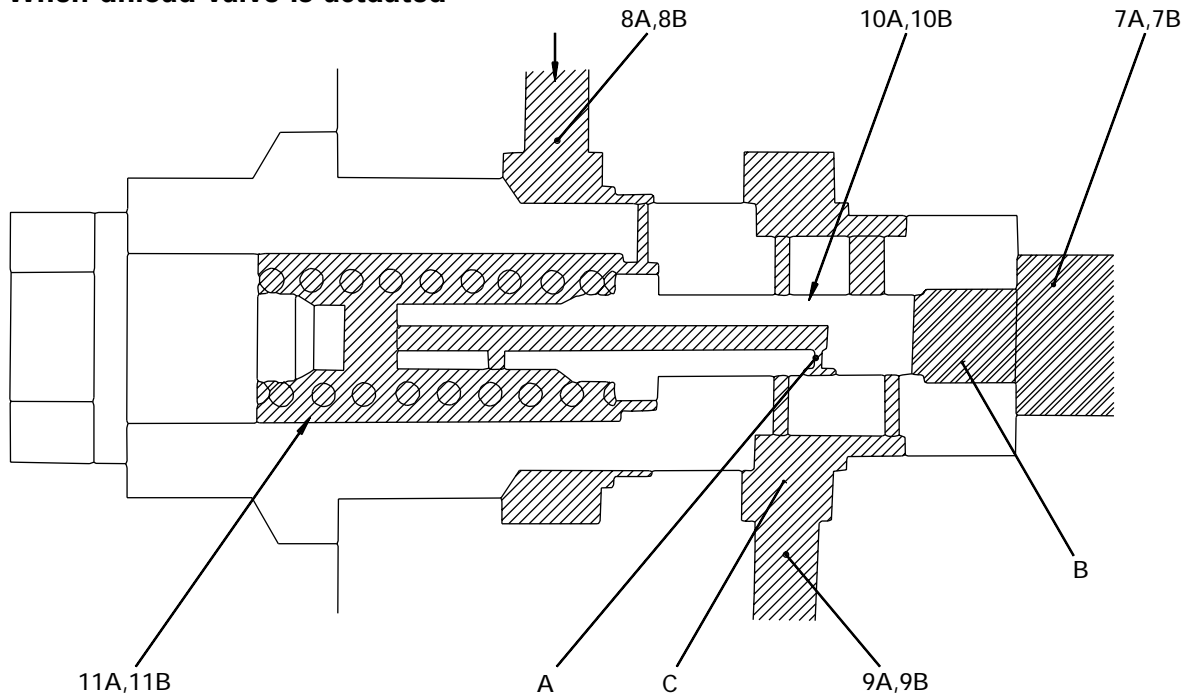

SBP00205

Function

- When all the control valves are at neutral, the oil discharged when the pump is at the minimum swash plate angle is drained. When this happens, the pump pressure becomes a pressure that matches the set load of springs (11A, 11B) inside the valve (**P1** pressure). The **LS** pressure is drained from LS bypass valve (12), so **LS** pressure \approx tank pressure \approx 0 MPa (0 kg/cm²).
- When operated (for operations in the discharge range for the minimum swash plate angle), the discharge pressure of the oil discharged with the pump at the minimum swash plate angle is **LS** pressure + **P1** pressure. In other words, the **LS** control differential pressure (Δ **PLS**) of the oil discharged at the minimum swash plate angle is the **P1** pressure.

force of springs (11A, 11B), valves (10A, 10B) move to the left, ports **B** and **C** are connected and the pump pressure flows to tank passages (9A, 9B). In addition, the pressurized oil in LS circuits (8A, 8B) passes from orifice **A** through port **C**, and is drained to tank passages (9A, 9B). Therefore, when the valve is actuated, **LS** pressure \approx tank pressure.

- When the unload operation is carried out, the differential pressure (pump discharge pressure – **LS** circuit pressure) is greater than the pump **LS** control pressure, so a signal is sent to move the pump swash plate to the minimum angle.

Operation

- The pressure in pump passages (7A, 7B) is received by the end face of valves (10A, 10B). The control valve is at neutral, so the pressure in LS circuits (8A, 8B) is 0 MPa (0 kg/cm²).
- The pressurized oil in pump passages (7A, 7B) is stopped by valves (10A, 10B). There is no way for the pressurized oil discharged by the pump to escape, so the pressure rises. When this pressure becomes larger than the

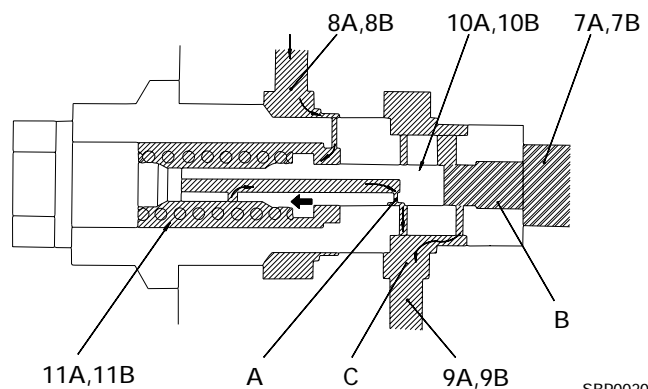

SBP00206

Operation

Simultaneous operation with work equipment under heavy load (boom RAISE, etc.)

1. The pump pressure and **LS** pressure are determined by the pressure of the other work equipment, but the cylinder port pressure becomes the actuating pressure of the attachment.

When the difference between the pump pressure and the cylinder pressure is less than the force of spring (5), then balance of the force acting on valve (1) is as follows.

$$P \times A1 = P \times A2 + LS (A2 - A1) + F$$

- (A1: Cross-sectional area of diameter D1)
- (A2: Cross-sectional area of diameter D2)
- F: Force of spring

2. If the difference between pump pressure **P** and the cylinder pressure becomes greater than the force of spring (5), poppet (4) is pushed to the right and the passage opens, so the pump passage is connected to the cylinder port through throttle **a**, chamber **g**, and passages **b** and **c**, and the oil flows to the cylinder port. When this happens, a differential pressure is formed between the upstream and downstream sides of throttle **a**, and the pressure in chamber **g** goes down, so the force pushing valve (1) to the left is reduced. In other words, the area ratio becomes smaller, so valve (1) moves to the right and increases the flow from the pump to the cylinder.

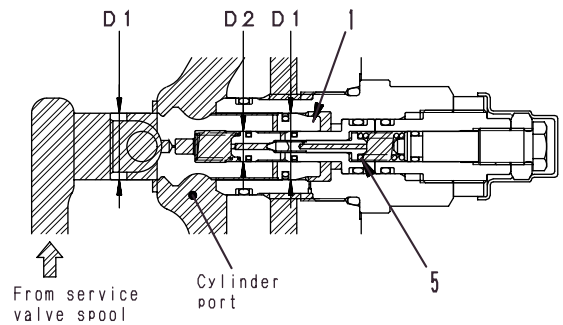

SWP05094

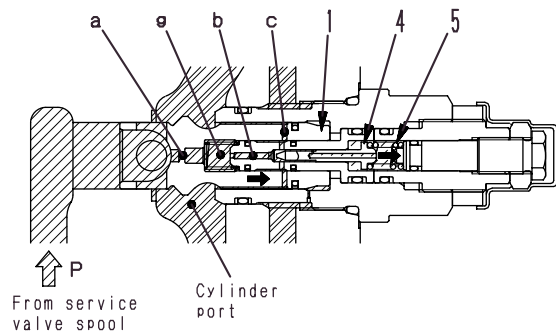

SWP05095

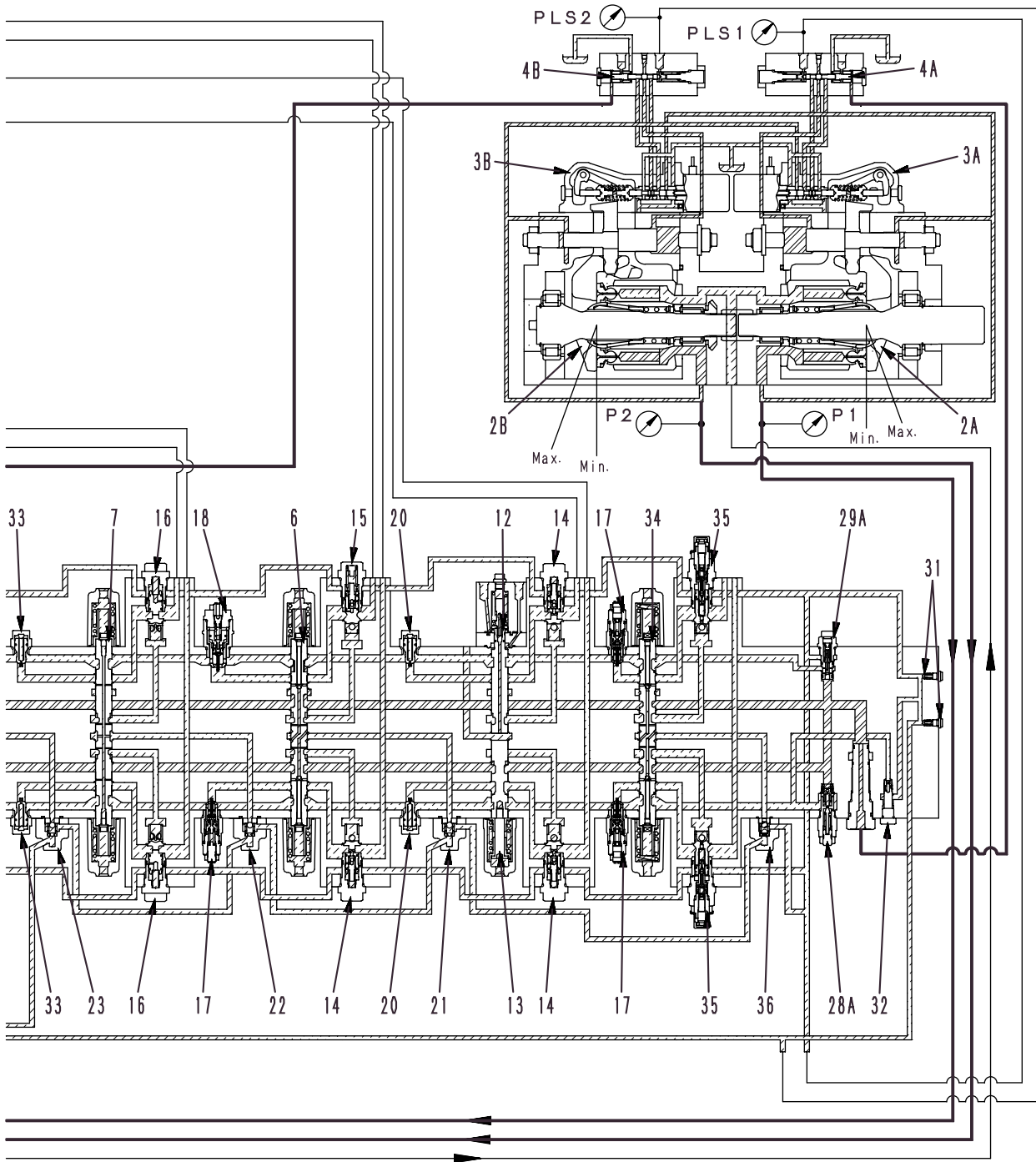

SWP04734

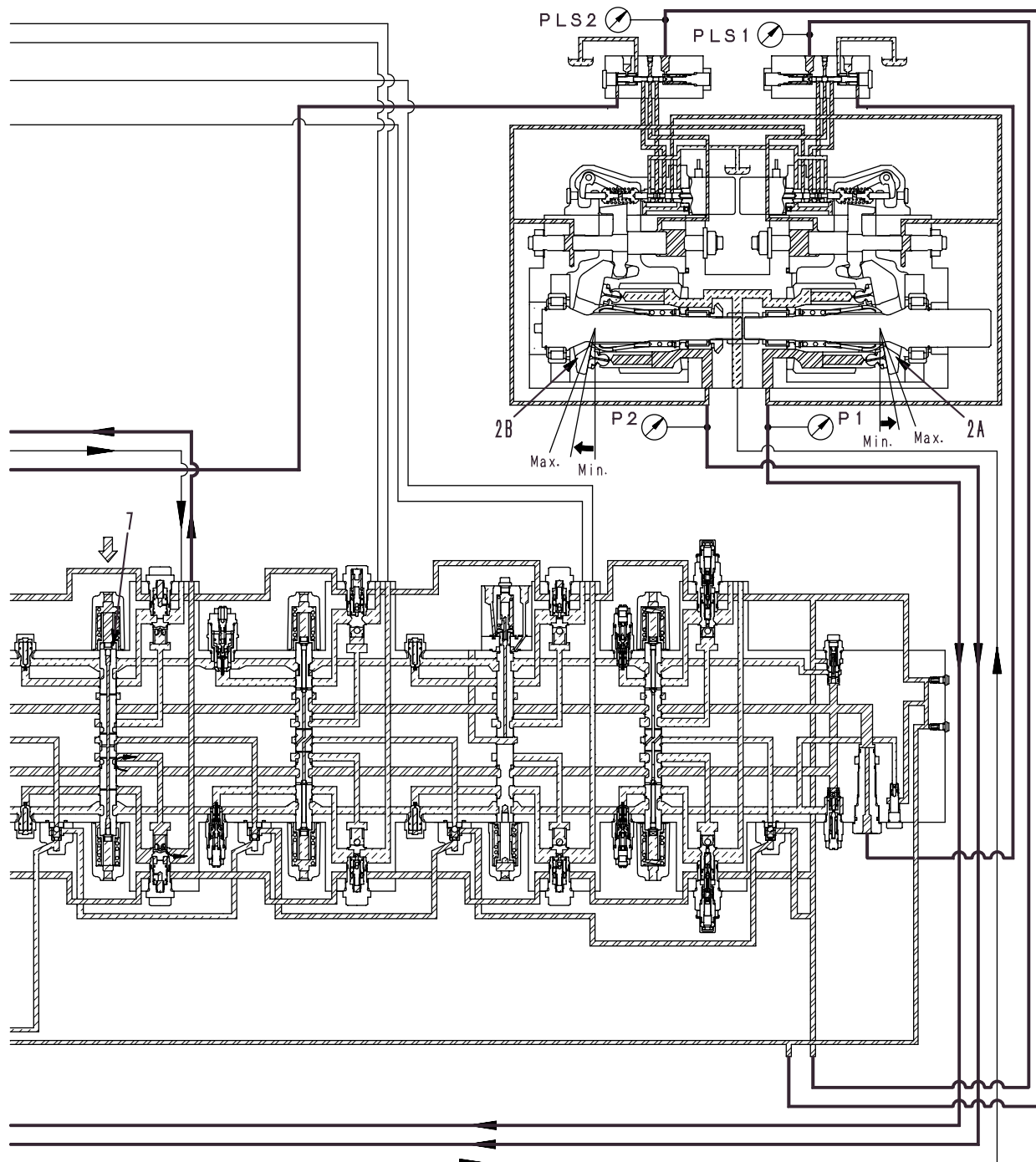

SWP04744

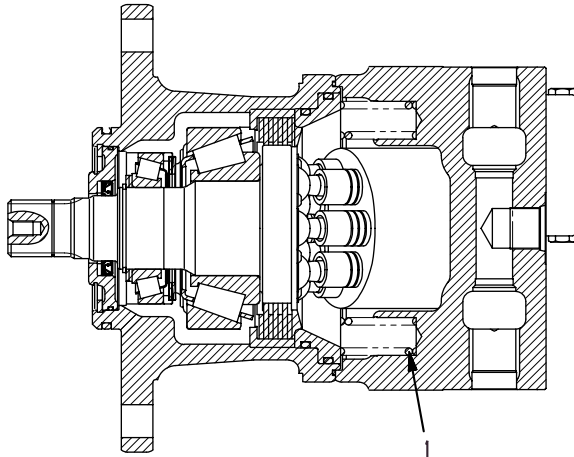

C - C

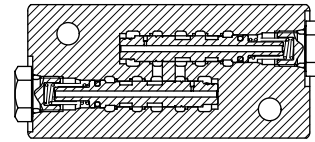

D - D

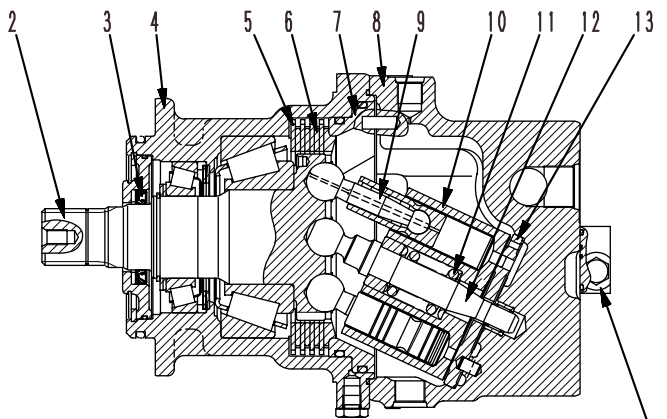

A - A

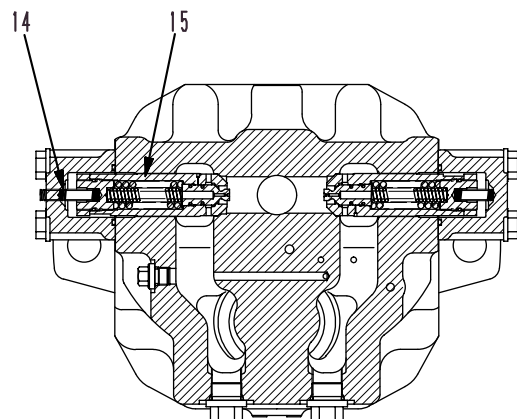

B - B

SWP04754

- 1. Spring
- 2. Output shaft
- 3. Oil seal
- 4. Case
- 5. Plate
- 6. Disc
- 7. Brake piston
- 8. Housing

- 9. Piston assembly
- 10. Cylinder block
- 11. Spring
- 12. Center shaft
- 13. Valve plate
- 14. Suction valve spring
- 15. Suction-safety valve
- 16. Reverse prevention valve

2) At high speed (motor swash plate angle at minimum)

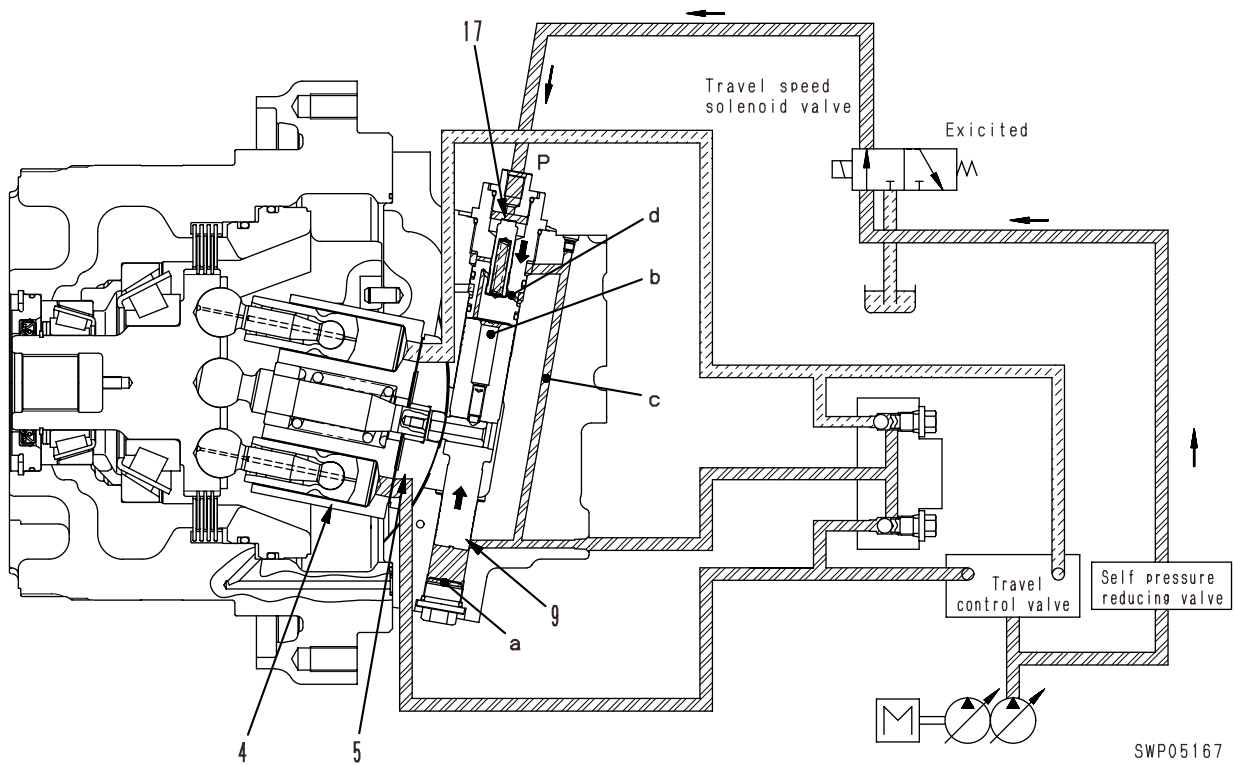

- When the solenoid valve is energized, the pilot pressure oil from the main pump flows to port **P**, and pushes regulator valve (17) down.
- When this happens, chamber **b** and the main pressure oil are shut off at regulator valve (17), and the oil at chamber **b** is drained inside the case.
- Because of this, the propulsion force of the pressure oil at chamber **a** of regulator piston (9) acts in an upward direction.
- As a result, valve plate (5) and cylinder block (4) move in the minimum swash plate angle direction, the motor capacity becomes minimum, and the system is set to high travel speed.

**3) During fine control
(when control lever is returned)**

When disc (5) starts to be returned, spool (1) is pushed up by the force of centering spring (3) and the pressure at port **P1**.

When this happens, fine control hole **f** is connected to drain chamber **D** and the pressure oil at port **P1** is released.

If the pressure at port **P1** drops too far, spool (1) is pushed down by metering spring (2), and fine control hole **f** is shut off from drain chamber **D**. At almost the same time, it is connected to pump pressure chamber **PP**, and the pump pressure is supplied until the pressure at port **P1** recovers to a pressure that corresponds to the lever position.

When the spool of the control valve returns, oil in drain chamber **D** flows in from fine control hole **f'** in the valve on the side that is not working. The oil passes through port **P2** and enters chamber **B** to fill the chamber with oil. (Fig. 3)

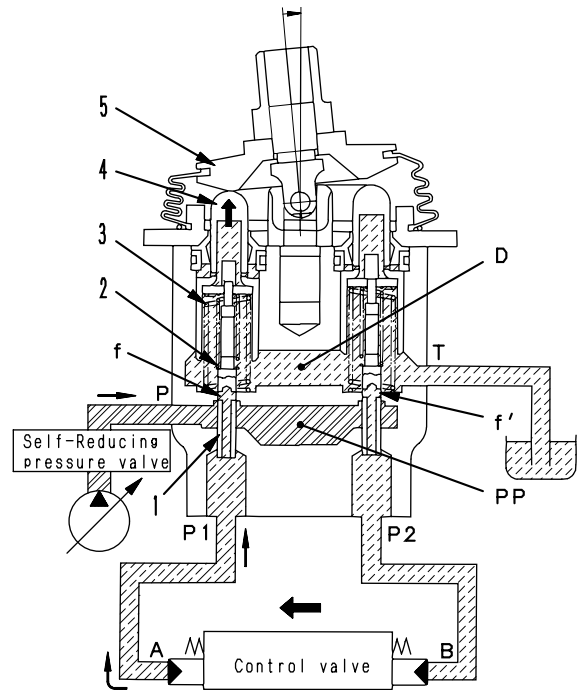

(Fig. 3)

SBP03495

4) At full stroke

When disc (5) pushes down piston (4), and retainer (9) pushes down spool (1), fine control hole **f** is shut off from drain chamber **D**, and is connected with pump pressure chamber **PP**. Therefore, the pilot pressure oil from the main pump passes through fine control hole **f** and flows to chamber **A** from port **P1**, and pushes the control valve spool.

The oil returning from chamber **B** passes from port **P2** through fine control hole **f'** and flows to drain chamber **D**. (fig. 4)

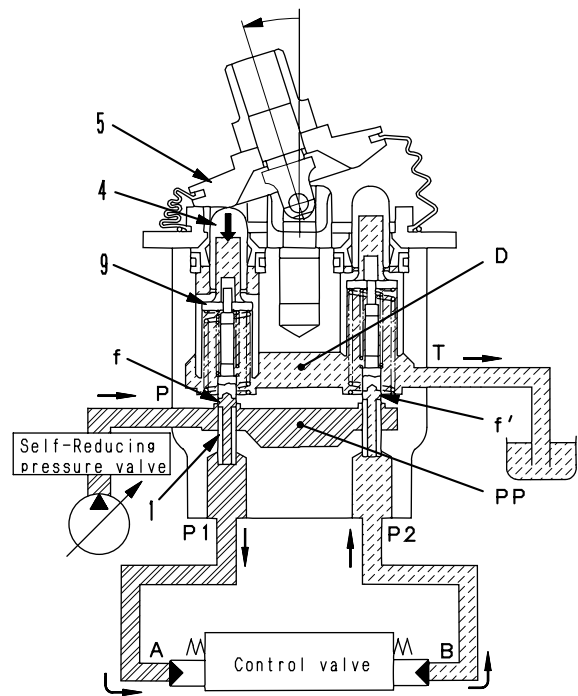

(Fig. 4)

SBP03496

PPC SHUTTLE VALVE, TRAVEL JUNCTION VALVE

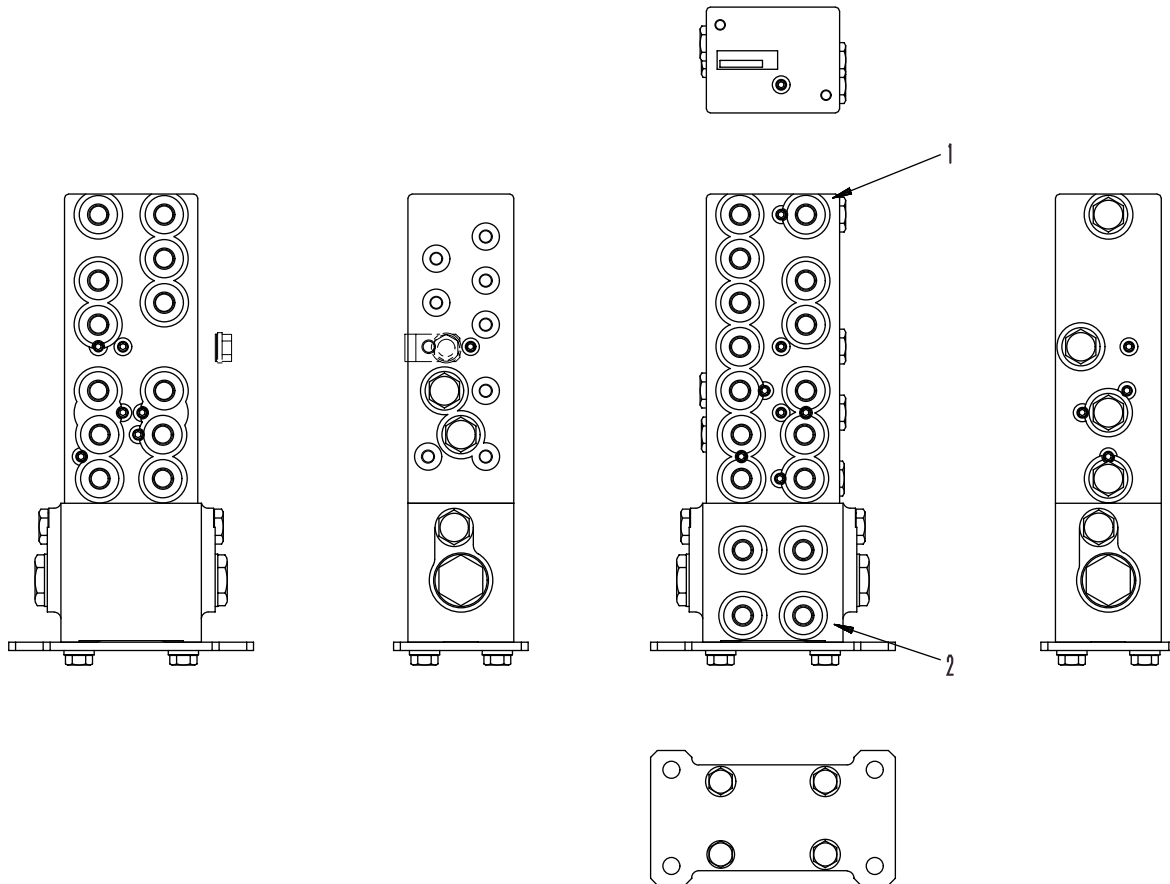

SDP01315

1. PPC shuttle valve
2. Travel junction valve

Outline

- The PPC shuttle valve and travel junction valve form a combined structure.

ACTUAL ELECTRIC WIRING DIAGRAM

(1/2)

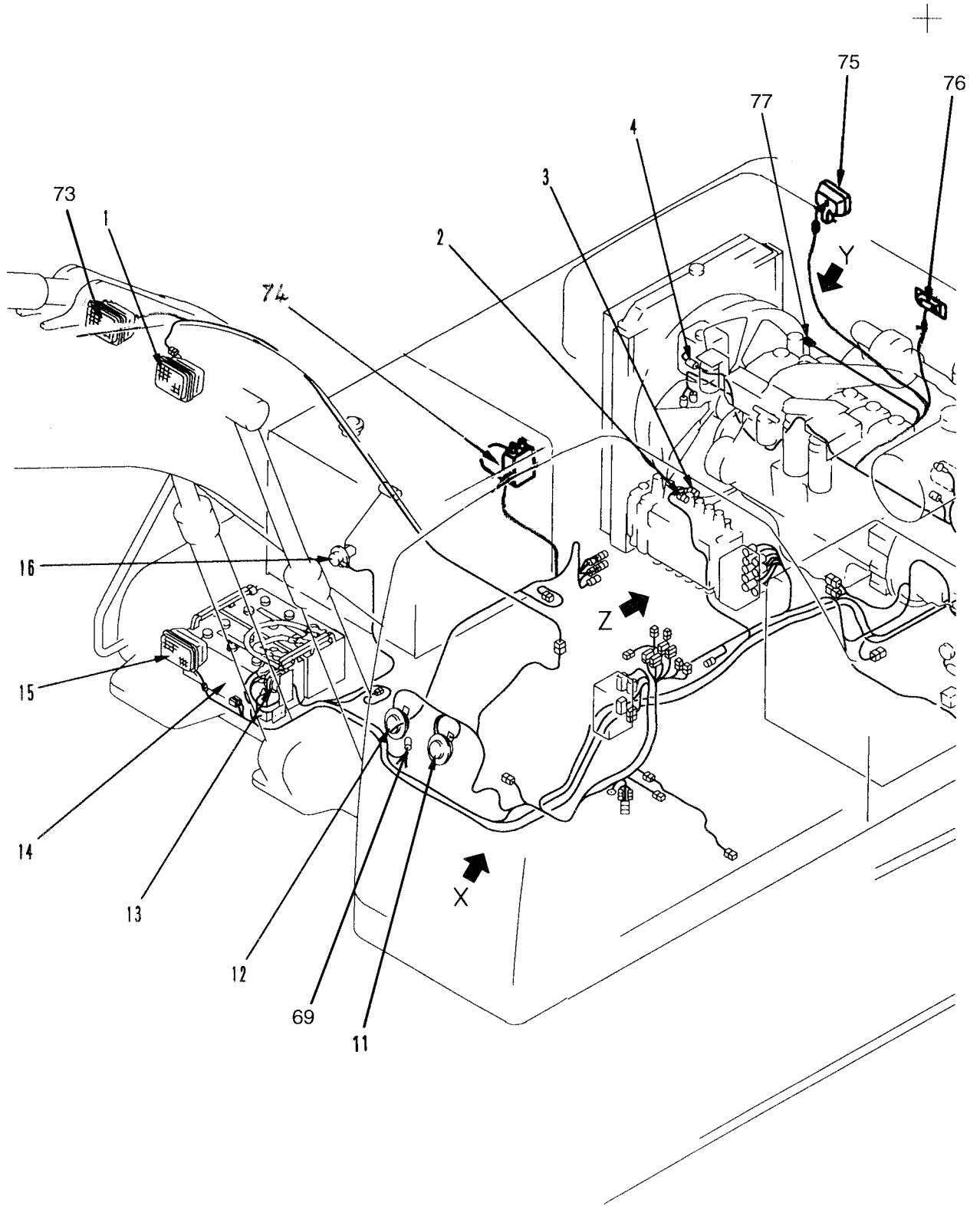

SWP05029

Governor motor

- 1. Potentiometer
- 2. Cover
- 3. Shaft
- 4. Dust seal
- 5. Bearing
- 6. Motor
- 7. Gear
- 8. Connector

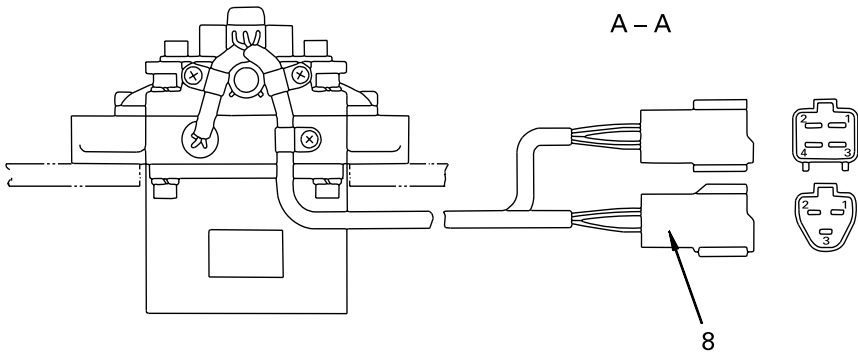
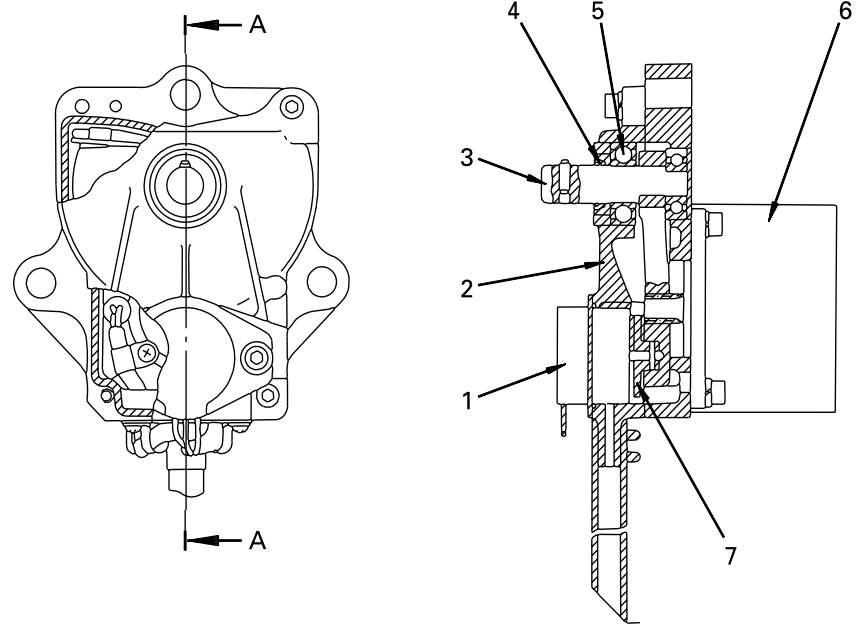

Composition of circuit

1	A	Black
2	Ā	Green
3	B	Red
4	B̄	Yellow
1	AP	A
2	AP sig	→
3	AP	A

SBP00326

Function

- The motor is rotated and the governor lever of the fuel injection pump is controlled by the drive signal from the governor and pump controller.
A stepping motor is used for the motor which provides the power.
- In addition, a potentiometer for giving feedback is installed to allow observation of the operation of the motor.
- The rotation of the motor is transmitted to the potentiometer through a gear.

Operation

- Motor stationary
- Both A phase and B phase of the motor are continuous, and a holding torque is generated in the motor.
- Motor rotating
- A pulse current is applied to the A phase and B phase from the governor and pump controller to give synchronous rotation with the pulse.

2) Control function when TVC prolix switch is ON

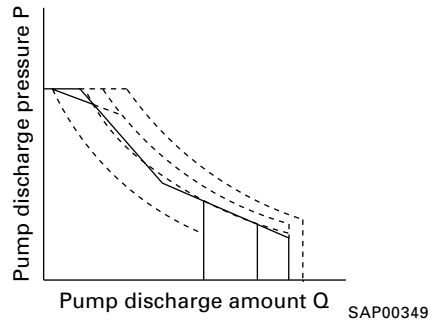
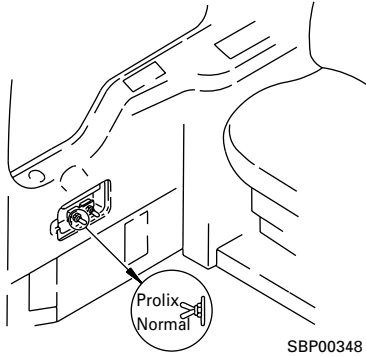

- Even if any abnormality should occur in the controller or sensor, the TVC prolix switch can be turned ON to provide an absorption torque more or less equivalent to the general operation mode, thereby allowing the machine to maintain its functions.

In this case, it is designed to allow a constant current to flow from the battery to the TVC valve, so oil pressure sensing is carried out only by the TVC valve.

1) Engine automatic warming-up function

- After the engine is started, if the engine coolant temperature is low, the engine speed is automatically raised to warm up the engine.

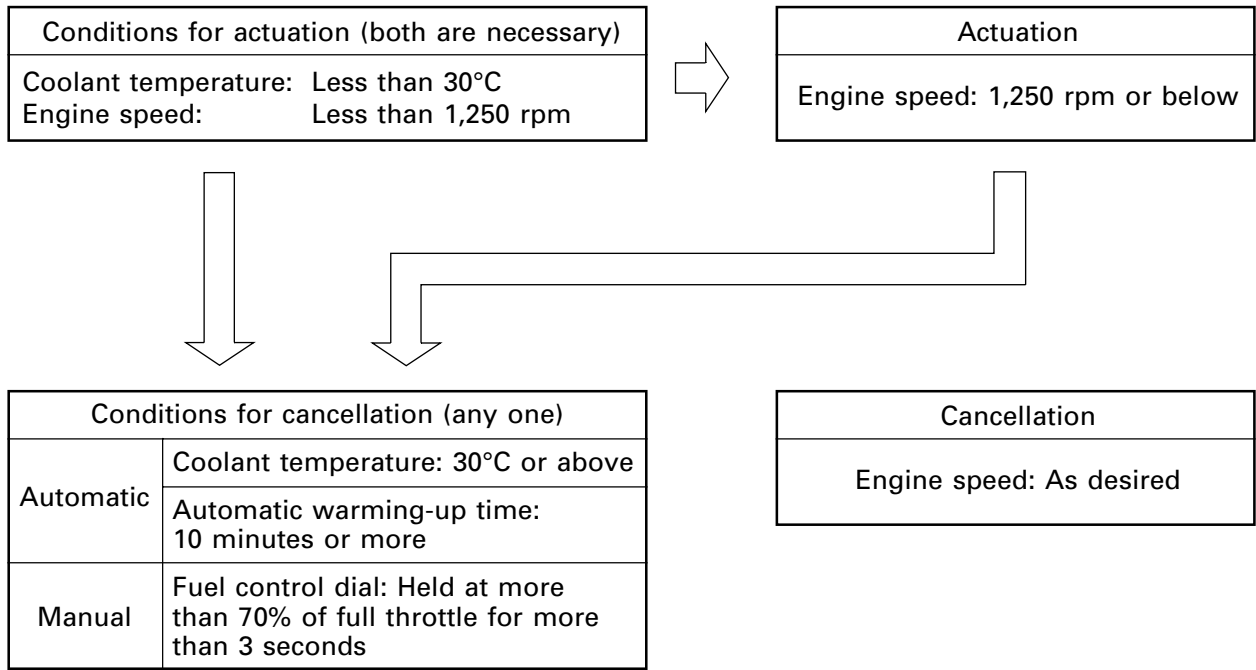

2) Engine overheat prevention function

- This function protects the engine by lowering the pump load and engine speed to prevent overheating when the engine coolant temperature has risen too far.
- This system is actuated when the water temperature is 105°C and above.

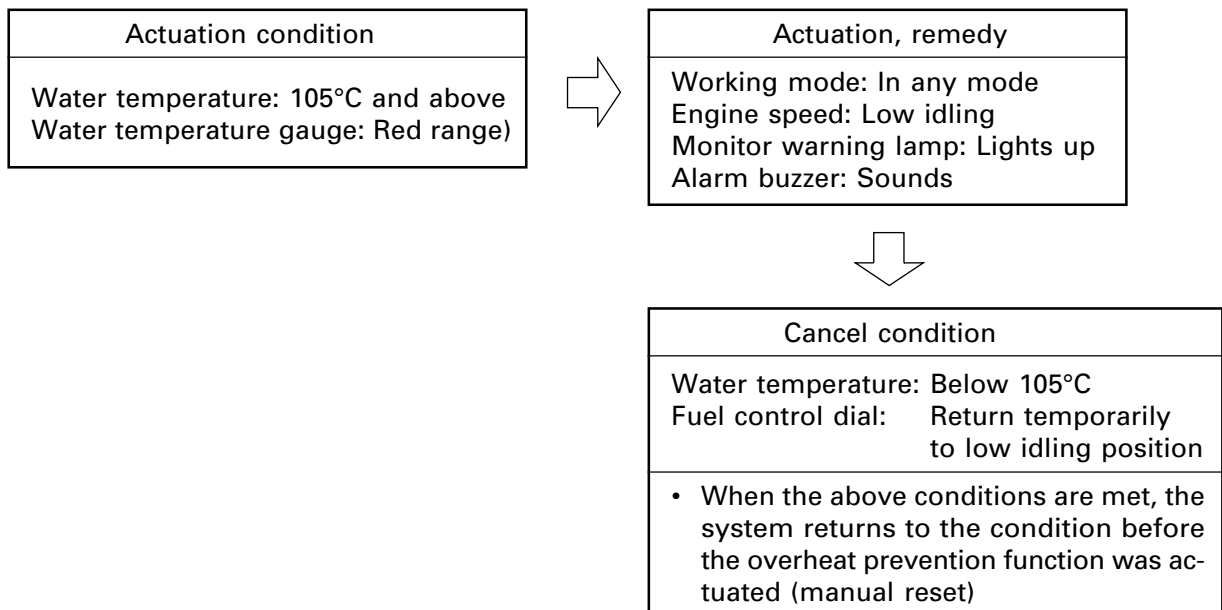

**Engine oil level sensor
Hydraulic oil level sensor**

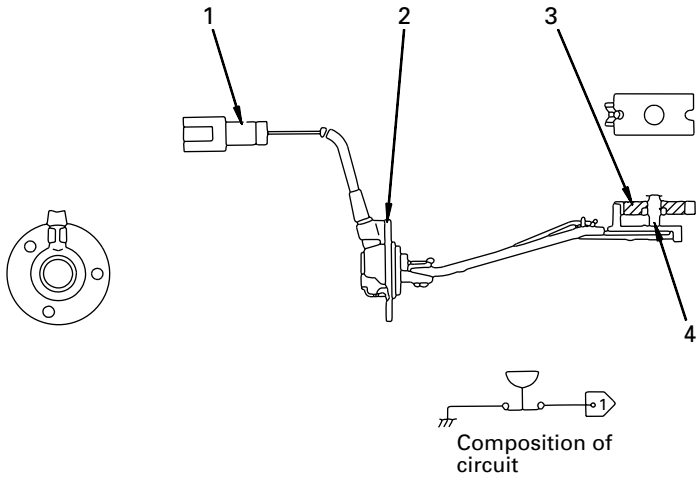

- 1. Connector
- 2. Bracket
- 3. Float
- 4. Switch

SBP00376

Engine oil pressure sensor (both Lo and Hi)

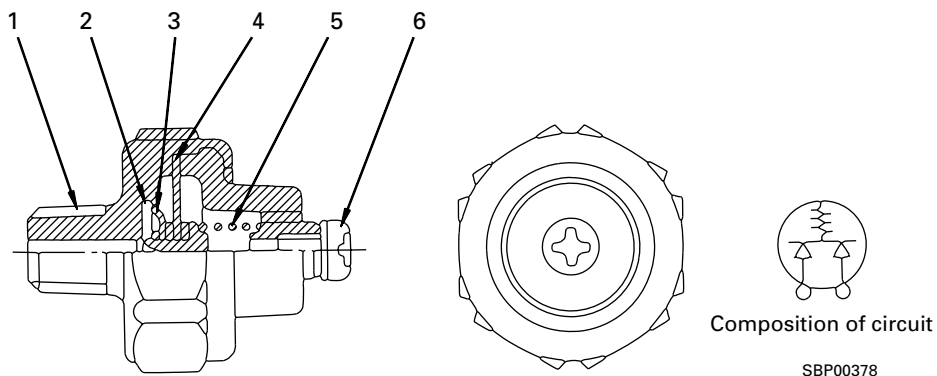

- 1. Plug
- 2. Contact ring
- 3. Contact
- 4. Diaphragm
- 5. Spring
- 6. Terminal

SBP00378

Coolant temperature sensor

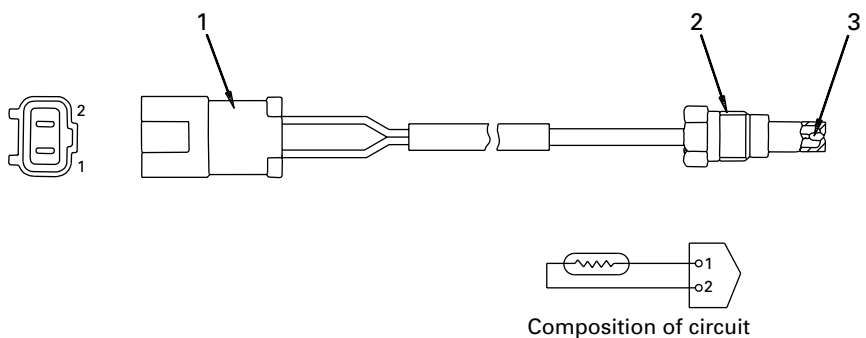

- 1. Connector
- 2. Plug
- 3. Thermistor

SBP00379

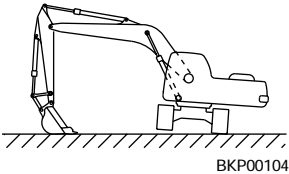
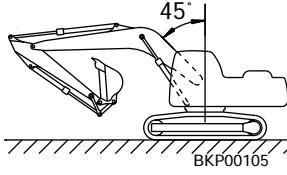
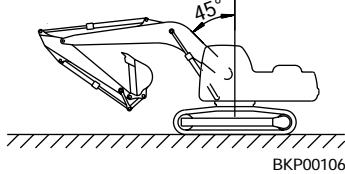
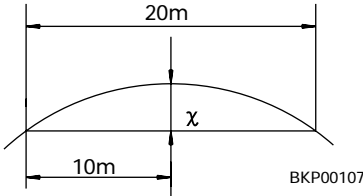
Applicable model				PC450-6K				
Category	Item	Measurement conditions	Unit	Standard value for new machine		Service limit value		
Travel	Travel speed (1)	 <ul style="list-style-type: none"> · Engine at full throttle · Hydraulic oil temperature: 45 - 55° · In heavy duty operation mode (H/O mode) · Raise track on one side, rotate one turn, then measure time taken for next 5 turns with no load. 	Travel speed	STD	LC	STD	LC	
			Lo	59.5 ± 6.0	63.5 ± 6.5	53.5 - 71.5	57.0 - 76.5	
			Mi	42.0 ± 5.5	44.5 ± 6.0	36.5 - 51.0	38.5 - 56.5	
				Hi	34.5 ± 3.5	36.5 ± 3.7	31.0 - 41.5	32.8 - 43.9
	Travel speed (2)	 <ul style="list-style-type: none"> · Engine at full throttle · Hydraulic oil temperature: 45 - 55° · In heavy duty operation mode (H/O mode) · Run up for at least 10 m, and measure time taken to travel next 20 m on flat ground. 	Lo	22.5 ± 4.4		19.0 - 29.5		
			Mi	15.9 ± 2.1		13.8 - 20.1		
			Hi	13.1 ± 1.0		12.1 - 15.1		
	Travel deviation	 <ul style="list-style-type: none"> · Engine at full throttle · Hydraulic oil temperature: 45 - 55°C · In heavy duty operation mode (H/O mode) · Travel speed : Hi · Run up for at least 10 m, and measure deviation when traveling next 20 m on flat ground. ★ Use a hard flat ground.  <ul style="list-style-type: none"> ★ Measure dimension χ. 	mm	Max. 200		Max. 300		

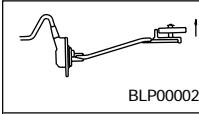
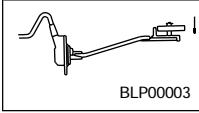
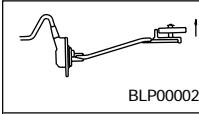
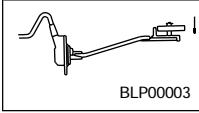
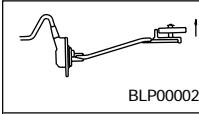
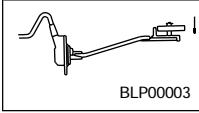
System	Name of component	Connector No.	Inspection method	Judgment table	Measurement conditions					
Monitor	Air cleaner clogging switch	P11 (male) P12 (female)	Continuity	If the condition is as shown in the table below, it is normal <table border="1" style="margin-top: 10px;"> <tr> <td>Air cleaner normal</td> <td rowspan="2">Between P11 – P12</td> <td>Continuity</td> </tr> <tr> <td>Air cleaner clogged</td> <td>No continuity</td> </tr> </table>	Air cleaner normal	Between P11 – P12	Continuity	Air cleaner clogged	No continuity	1) Start engine. 2) Disconnect P11, P12.
	Air cleaner normal	Between P11 – P12	Continuity							
	Air cleaner clogged		No continuity							
	Engine speed sensor	E07	Measure resistance	If the condition is within the range shown in the table below, it is normal <table border="1" style="margin-top: 10px;"> <tr> <td>Between (1) – (2)</td> <td>500 – 1000 Ω</td> </tr> <tr> <td>Between (1),(2) – chassis</td> <td>Min. 1 MΩ</td> </tr> </table>	Between (1) – (2)	500 – 1000 Ω	Between (1),(2) – chassis	Min. 1 MΩ	1) Turn starting switch OFF. 3) Disconnect connector.	
			Between (1) – (2)	500 – 1000 Ω						
			Between (1),(2) – chassis	Min. 1 MΩ						
Measure voltage	Measure with AC range <table border="1" style="margin-top: 10px;"> <tr> <td>Between (1) – (2)</td> <td>0.5 – 3.0 V</td> </tr> </table>	Between (1) – (2)	0.5 – 3.0 V	1) Start engine. 2) Insert T – adapter.						
Between (1) – (2)	0.5 – 3.0 V									
Adjust	1) Screw in rotation sensor until it contacts ring gear, then turn back $1 \pm 1/6$ turns 2) It must work normally when adjusted as above.									
Water level switch	P08 (male)	Measure resistance	If the condition is as shown in the table below, it is normal <table border="1" style="margin-top: 10px;"> <tr> <td>Above LOW level in sub-tank</td> <td>Max. 1 Ω</td> </tr> <tr> <td>Below LOW level in sub-tank</td> <td>Min. 1 MΩ</td> </tr> </table>	Above LOW level in sub-tank	Max. 1 Ω	Below LOW level in sub-tank	Min. 1 MΩ	1) Turn starting switch OFF. 2) Disconnect connector P08. 3) Insert T – adapter into connector at sensor end.		
Above LOW level in sub-tank	Max. 1 Ω									
Below LOW level in sub-tank	Min. 1 MΩ									
Engine oil level switch	P05 (male)	Measure resistance	If the condition is as shown in the table below, it is normal <table border="1" style="margin-top: 10px;"> <tr> <td>  Raise float BLP00002 </td> <td>Max. 1 Ω</td> </tr> <tr> <td>  Lower float BLP00003 </td> <td>Min. 1 MΩ</td> </tr> </table>	 Raise float BLP00002	Max. 1 Ω	 Lower float BLP00003	Min. 1 MΩ	1) Turn starting switch OFF. 2) Disconnect connector P05. 3) Drain oil, then remove sensor.		
 Raise float BLP00002	Max. 1 Ω									
 Lower float BLP00003	Min. 1 MΩ									
Water temperature sensor	P07 (male)	Measure resistance	If the condition is as shown in the table below, it is normal <table border="1" style="margin-top: 10px;"> <tr> <td>Normal temperature (25°C)</td> <td>Approx. 37 – 50 kΩ</td> </tr> <tr> <td>100°C</td> <td>Approx. 3.5 – 4.0 kΩ</td> </tr> </table>	Normal temperature (25°C)	Approx. 37 – 50 kΩ	100°C	Approx. 3.5 – 4.0 kΩ	1) Turn starting switch OFF. 2) Disconnect connector P07. 3) Insert T – adapter into connector at sensor end.		
Normal temperature (25°C)	Approx. 37 – 50 kΩ									
100°C	Approx. 3.5 – 4.0 kΩ									

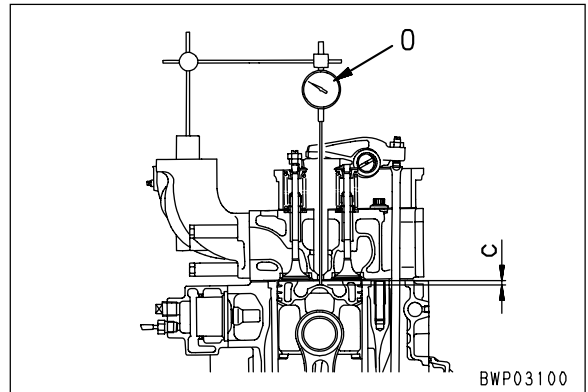

6. Rotate the crankshaft approx. 45° in the reverse direction.
7. Rotate the crankshaft again in the normal direction until the dimension becomes specified dimension "c". (Always rotate the crankshaft in the normal direction to align the position.)
 - ★ Specified dimension c: 3.8 ± 0.2 mm
 - ★ When specified dimension "c" is correct, check that line "a" on the fuel injection pump body is aligned with line "b" on the coupling.
8. Rotate the crankshaft in the normal direction and check again that when the No. 1 cylinder reaches top dead center (the dial gauge indicator starts to move in the opposite direction), the dial gauge display is 0 ± 0.2 mm. If it is not 0 ± 0.2 mm, carry out the adjustment again from Step 5.

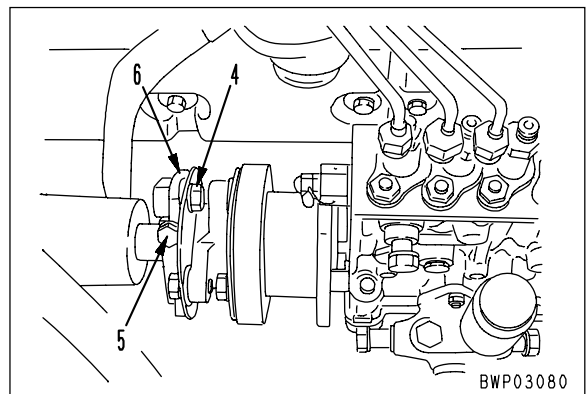

Adjusting

- ★ If the fuel injection timing is not correct, adjust as follows.
- ★ Set the crankshaft to specified dimension "c" (see Step 7 above) when adjusting.



1. Loosen 2 mounting bolts and nuts (4) and 1 mounting bolt (5), and set so that coupling (6) is free.
2. Align line "a" on the fuel injection pump with line "b" on the coupling.
3. Tighten 2 mounting bolts and nuts (4), then tighten 1 mounting bolt (5).
 -  Mounting bolt, nut (4):
58.8 – 63.7 Nm {6.0 – 6.5 kgm}
 -  Mounting bolt (5):
73.5 – 83.3 Nm {7.5 – 8.5 kgm}

Adjusting

★ If the load becomes larger, the engine speed will drop. Or if the engine speed remains normal, the work equipment speed will drop. In such cases, if the pump discharge pressure and LS differential pressure are normal, adjust the TVC valve as follows.

1. Loosen locknut (1), and turn screw (2) to adjust.
 - ★ The direction to turn differs according to the position of the eccentric position punch mark on the screw, so check the mark before turning.
 - ★ Turn the screw as follows.
 - If work equipment is slow, turn in INCREASE direction
 - If engine speed drops, turn in DECREASE direction.

Punch mark	Increase	Decrease
Range (A)	Within 90° in counterclockwise direction	Within 90° in clockwise direction
Range (B)	Within 90° in clockwise direction	Within 90° in counterclockwise direction

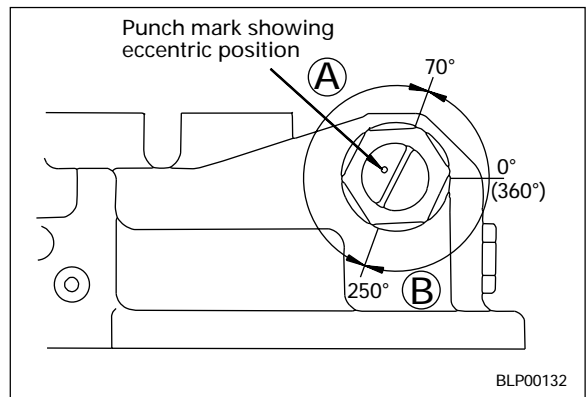
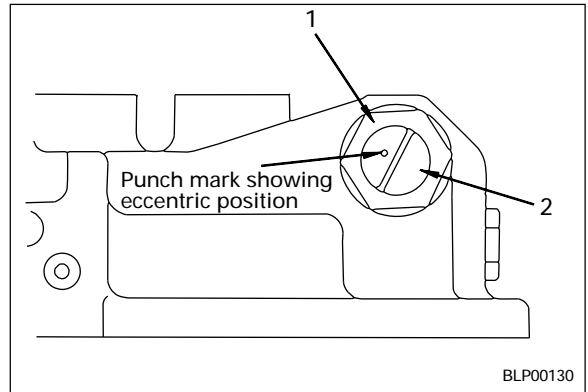

2. After completing the adjustment, tighten locknut (1).

Locknut : **24.5 – 34.3 Nm {2.5 – 3.5 kgm}**

Note: The screw is an eccentric cam, so if it is turned from the 0 position in the graph, the stroke of the servo piston (change in oil flow) will move as shown in the graph. If it is turned one full turn, it will return to the original position, but the screw will become looser, so there will be play in the screw. Therefore, turn the screw a maximum of 90° to the left or right from the position set when the machine was shipped.

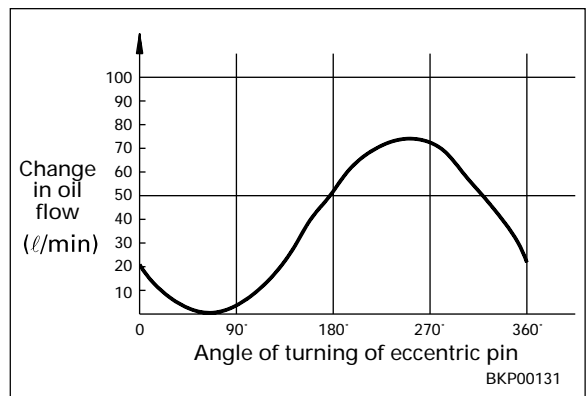

ADJUSTING WORK EQUIPMENT, SWING PPC VALVE

★ If there is excessive play in the work equipment or swing lever, adjust as follows.

⚠ Lower the work equipment to the ground and stop the engine. Loosen the oil filler cap slowly to release the pressure inside the hydraulic tank. Then set the safety lock lever to the LOCK position.

1. Remove the PPC valve assembly.
For details, see DISASSEMBLY AND ASSEMBLY, Removal of work equipment PPC valve assembly.
 2. Remove boot (1).
 3. Loosen locknut (2), then screw in disc (3) until it contacts the 4 heads of piston (4).
★ When doing this, do not move the piston.
 4. Secure disc (3) in position, then tighten locknut (2) to the specified torque.
 Locknut : **98 – 127 Nm {10 – 13 kgm}**
 5. Install boot (1).
- ★ With the above adjustment, the clearance between disc (3) and piston (4) becomes 0.

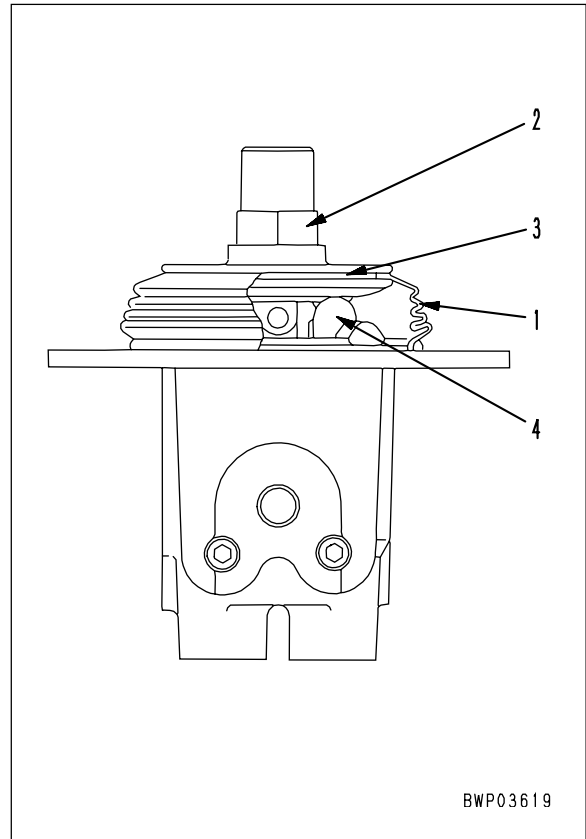

BWP03619

BLEEDING AIR

Order for operations and procedure for bleeding air

Air bleeding item	Air bleeding procedure					
	1	2	3	4	5	6
Nature of work	Bleeding air from pump	Start engine	Bleeding air from cylinder	Bleeding air from swing motor	Bleeding air from travel motor	Start operations
• Change hydraulic oil • Clean strainer	○ →	○ →	○ →	○ (note) →	○ (note) →	○
• Replace return filter element		○				○
• Replace, repair pump • Remove suction piping	○ →	○ →	○ →			○
• Replace, repair control valve		○ →	○ →			○
• Replace cylinder • Remove cylinder piping		○ →	○ →			○
• Reoplace swing motor • Remove swing motor piping		○		○		○
• Replace travel motor, swivel • Remove travel motor, swivel piping		○			○	○

Note: Bleed the air from the swing and travel motors only when the oil inside the motor case has been drained.

1. Bleeding air from pump

- Loosen air bleed plug (1), and check that oil oozes out from the plug.
- When oil oozes out, tighten plug(1).

 Air bleed plug:
7.8 – 9.8 Nm {0.8 – 1.0 kgm}

- ★ If no oil oozes out from the air bleed plug:
- Leave plug (1) loosened and remove drain hose (2) and elbow (3).
 - Pour in oil through the elbow mount hole until oil oozes out from plug (1).
 - Fit elbow (3) and install drain hose (2).
 - Tighten air bleed plug (1).

 Air bleed plug:
7.8 – 9.8 Nm {0.8 – 1.0 kgm}

- ★ Precautions when starting the engine
After completing the above procedure and starting the engine, run the engine at low idling for 10 minutes.
- ★ If the coolant temperature is low and automatic warming-up is carried out, cancel it by using the fuel control dial after starting the engine.

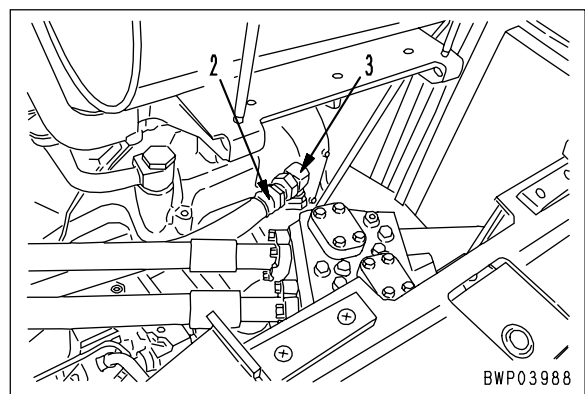
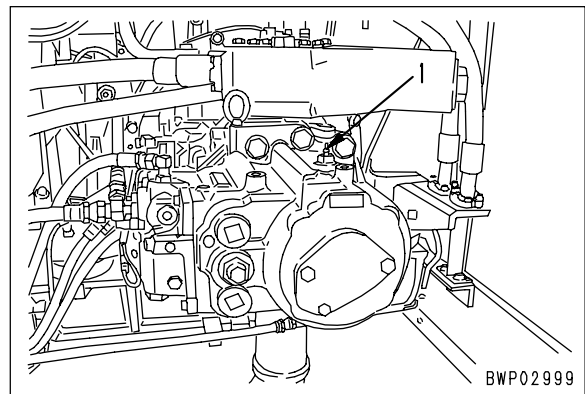

- **Drying wiring harness**

If there is any oil or dirt on the wiring harness, wipe it off with a dry cloth. Avoid washing it in water or using steam. If the connector must be washed in water, do not use high-pressure water or steam directly on the wiring harness.

If water gets directly on the connector, do as follows.

- ① Disconnect the connector and wipe off the water with a dry cloth.
 - ★ If the connector is blown dry with compressed air, there is the risk that oil in the air may cause defective contact, so remove all oil and water from the compressed air before blowing with air.

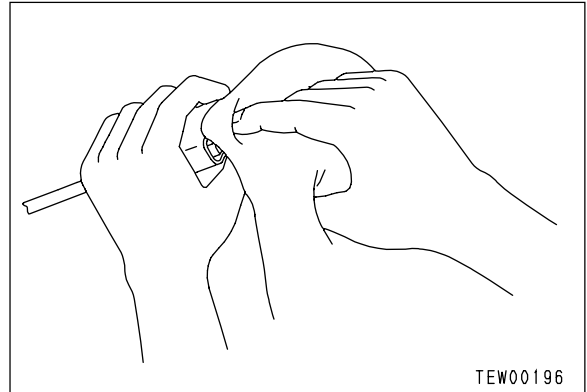

- ② Dry the inside of the connector with a dryer. If water gets inside the connector, use a dryer to dry the connector.
 - ★ Hot air from the dryer can be used, but regulate the time that the hot air is used in order not to make the connector or related parts too hot, as this will cause deformation or damage to the connector.

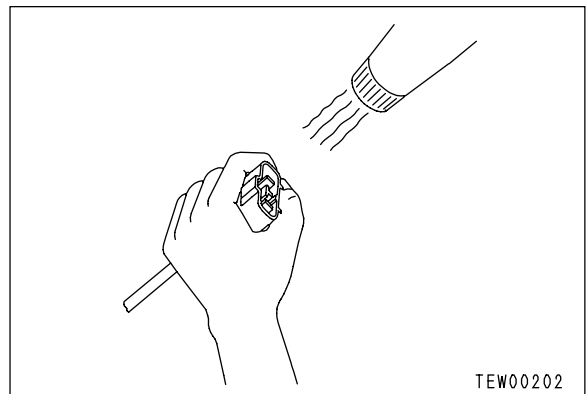

- ③ Carry out a continuity test on the connector. After drying, leave the wiring harness disconnected and carry out a continuity test to check for any short circuits between pins caused by water.
 - ★ After completely drying the connector, blow it with contact restorer and reassemble.

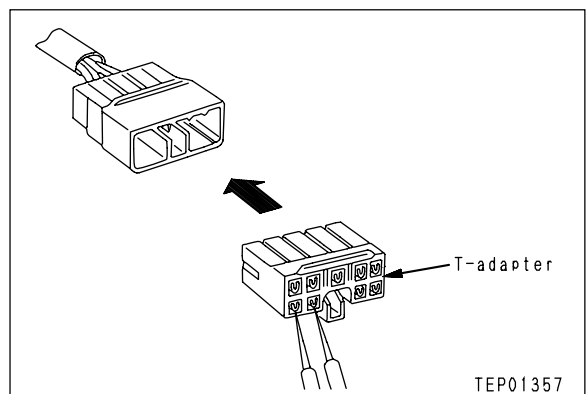

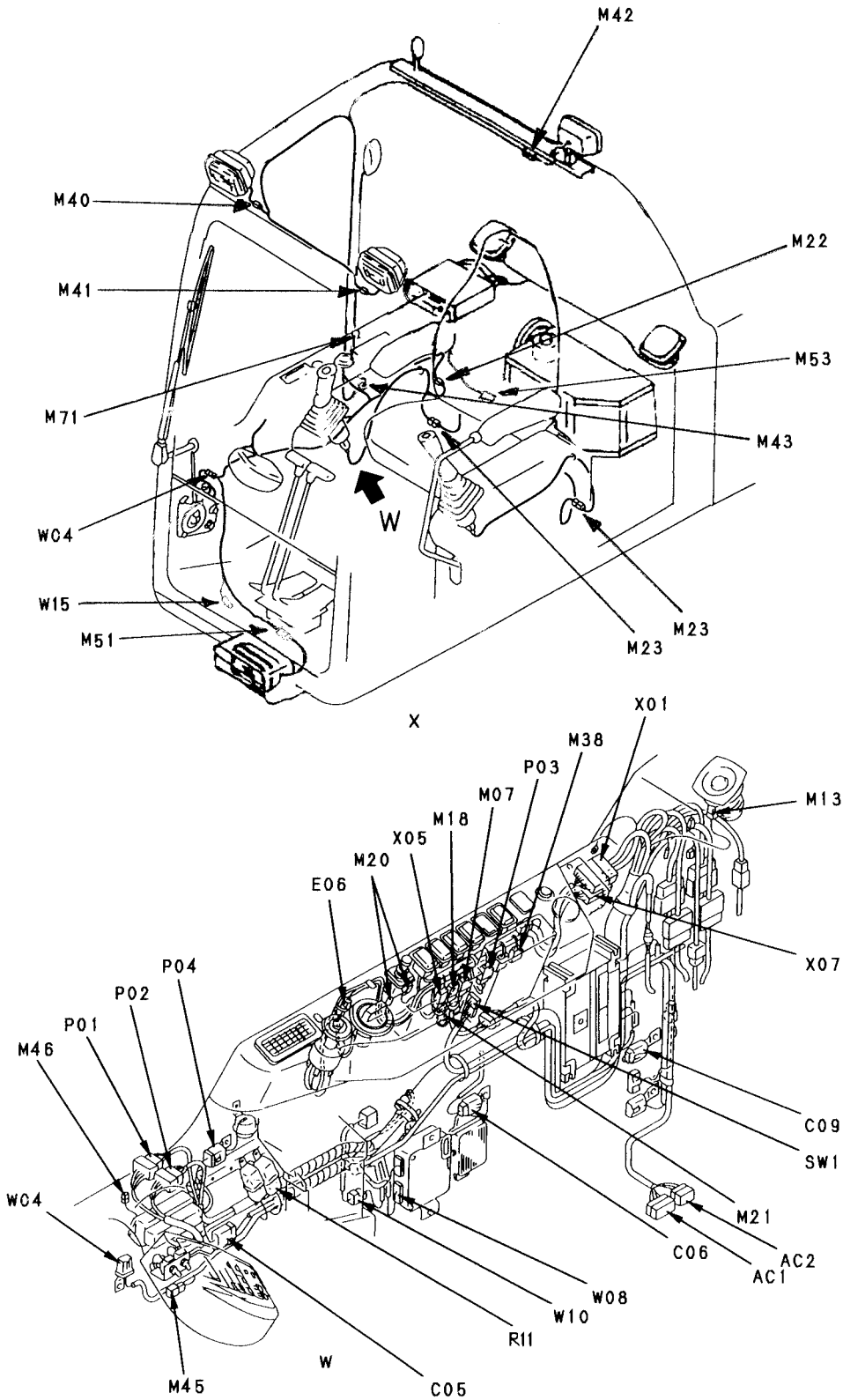

K	L	M	N	O	P
---	---	---	---	---	---

BWP03030

No. of pins	Relay connector	
	Male (female housing)	Female (male housing)
5	<p>BLP00073</p>	<p>BLP00074</p>
6	<p>BLP00075</p>	<p>BLP00076</p>

6. Working mode default setting mode

The default (initial position) for the working mode can be changed as follows (the default can be changed for the working mode only).

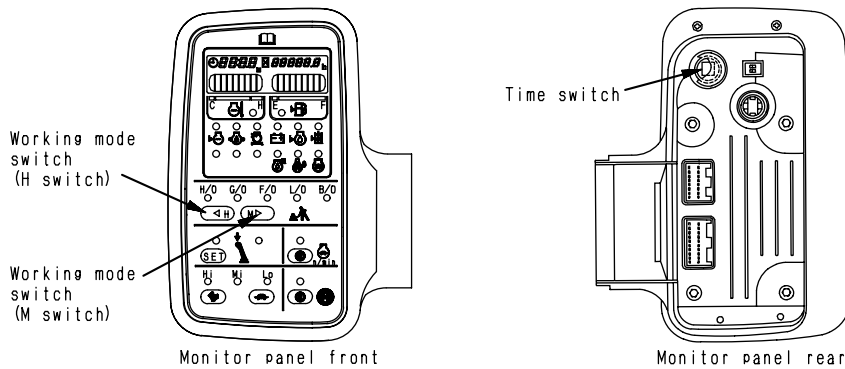

TWP01408

- 1) Set to the working mode default setting mode.
 - i) Keep the TIME switch and WORKING MODE SWITCH (M SWITCH) pressed at the same time for at least 2.5 seconds.
 - ii) Check that one of the working mode LEDs is flashing.
- 2) Method of setting working mode default
 - i) Use the WORKING MODE SWITCH (H SWITCH) or WORKING MODE SWITCH (M SWITCH) to change the working mode and set the working mode to the default to be changed.
 - ii) Keep the TIME switch and WORKING MODE SWITCH (M SWITCH) pressed at the same time for at least 2.5 seconds.
 - iii) When the setting is completed, the buzzer “beeps” (when the system returns to the normal mode, the working mode LED lights up).
 - ★ Note that if the starting switch is turned OFF when the LED is flashing (default setting mode), the content of the working mode default is not changed.
- 4) Method of checking after setting working mode default
 - i) Check that the LED remains lighted up.
 - ii) Turn the starting switch OFF, then turn it ON again.
 - iii) Check that the working mode default has changed to the new setting.
 - ★ When the starting switch is turned ON, the auto-deceleration setting changes according to the working mode.

SERVICE CODE TABLE

Service code	Abnormal system	User code	Service code	Abnormal system	User code
E101	Abnormality in error history data		E313	Error in auto-greasing controller (option)	
E102	Abnormality in time data		E315	Short circuit in battery relay output system	
E103	Short circuit in buzzer output, contact with 24V wiring harness for buzzer drive		E316	Step-out in governor motor	
E104	Air cleaner clogging detected		E317	Disconnection in governor motor system	E05
E106	Abnormality in engine oil pressure sensor (Hi) detected		E318	Short circuit in governor motor system	E05
E108	Water temperature over 105°C				
E112	Short circuit in wiper motor drive normal rotation system				
E113	Short circuit in wiper motor drive reverse rotation system				
E114	Short circuit in window washer drive system				
E203	Short circuit in swing holding brake solenoid system	E03			
E204	Short circuit in pump merge/divider solenoid system				
E206	Short circuit in travel speed solenoid system				
E207	Short circuit in active mode (boom) solenoid system				
E208	Disconnection in active mode (boom) solenoid system				
E213	Disconnection in swing holding brake solenoid system	E03			
E214	Disconnection in pump merge/divider solenoid system				
E216	Disconnection in travel speed solenoid system				
E217	Error in model selection input				
E218	Network response overtime error				
E222	Short circuit in LS-EPC solenoid system				
E223	Disconnection in LS-EPC solenoid system				
E224	Abnormality in F pump pressure sensor system				
E225	Abnormality in R pump pressure sensor system				
E226	Abnormality in pressure sensor system power source				
E227	Abnormality in engine speed sensor				
E231	Short circuit in active mode (swing) solenoid system				
E232	Short circuit in F pump TVC solenoid system	E02			
E233	Disconnection in F pump TVC solenoid system	E02			
E235	Disconnection in active mode (swing) solenoid system				
E236	Short circuit in R pump TVC solenoid system	E02			
E237	Disconnection in R pump TVC solenoid system	E02			
E306	Abnormality in feedback potentiometer system				
E308	Abnormality in fuel control dial input value	E05			

User code	Service code	Abnormal system	Nature of abnormality
—	E306	Abnormality in feedback potentiometer system	<ol style="list-style-type: none"> 1. Short circuit in wiring harness between C03 (7) – (14), (7) – (17), (14) – (17) 2. Short circuit in wiring harness between E04 (1) – (2), (1) – (3), (2) – (3) 3. Short circuit in wiring harness between E06 (1) – (2), (1) – (3), (2) – (3) 4. Short circuit in wiring harness between C03 (7) – (4), (4) – (17) 5. Disconnection in wiring harness between C03 (7) – E04 (1) 6. Disconnection in wiring harness between C03 (14) – E04 (2) 7. Disconnection in wiring harness between C03 (17) – E04 (3) 8. Defective governor motor potentiometer 9. Defective contact of C03, E04 connectors
—	E315	Abnormality (short circuit) in battery relay output system	<p>If excess current flows between C03 (1) and battery relay</p> <p>★ This occurs only when turning starting switch to OFF and stopping engine</p>
—	E316	Abnormality (step-out) in motor	<ol style="list-style-type: none"> 1. Defective adjustment of rod or scuffing of loose spring 2. Abnormality in governor motor 3. Abnormality in governor, pump controller

E-5 [E306] Abnormality in feedback potentiometer system is displayed

- ★ This troubleshooting is carried out when there is still an abnormality, so when disconnecting the connector and inserting the T-adaptor, or when removing the T-adaptor and returning the connector to its original position, if the service code E is not displayed, the problem has been removed.
- ★ Before carrying out troubleshooting, check that all the related connectors are properly inserted.
- ★ Always connect any disconnected connectors before going on the next step.

	Cause	Remedy
<div style="border: 1px solid black; padding: 5px; margin-bottom: 10px;"> Is resistance between E06 (male) (1)-(2), (2)-(3) as shown in Table 1? </div> <div style="margin-left: 20px;"> YES → 1 </div> <div style="margin-left: 20px;"> NO → Turn starting switch OFF. Disconnect E04. </div> <div style="border: 1px solid black; padding: 5px; margin-left: 20px; margin-top: 10px;"> Is resistance between each pin of C03 (female) (4) (7) (14), or between each pin and chassis as shown in Table 1? </div> <div style="margin-left: 20px;"> YES → 2 </div> <div style="margin-left: 20px;"> NO → Turn starting switch OFF. Disconnect C03. </div>	Defective governor, pump controller Defective wiring harness in system with defective resistance Defective governor motor	Replace Replace Replace

- ★ If E308 also occurs at the same time, check the wiring harness below.
 - Wiring harness between C03 (female) (7) – X07 (6) – E06 (female) (1) short circuiting with ground, or contact with other wiring harness

Table 1

C03 (female)	E04 (male)	Resistance value
(7) – (4)	(1) – (2)	0.25 – 7kΩ
(14) – (17)	(2) – (3)	0.25 – 7kΩ
(7) – (17)	—	2 – 3kΩ
—	(1) – (3)	4 – 6kΩ
Between each pin and chassis	—	Min. 1 MΩ

E-5 Related electric circuit diagram

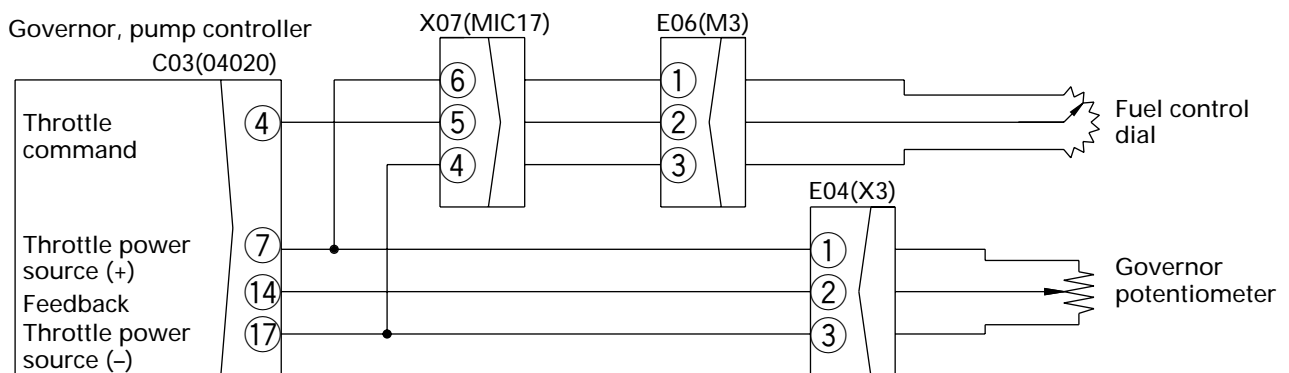

BKP00097

E-10 Lack of output (engine high idling speed is too low)

- ★ Before carrying out troubleshooting, check that all the related connectors are properly inserted.
- ★ Always connect any disconnected connectors before going on the next step.

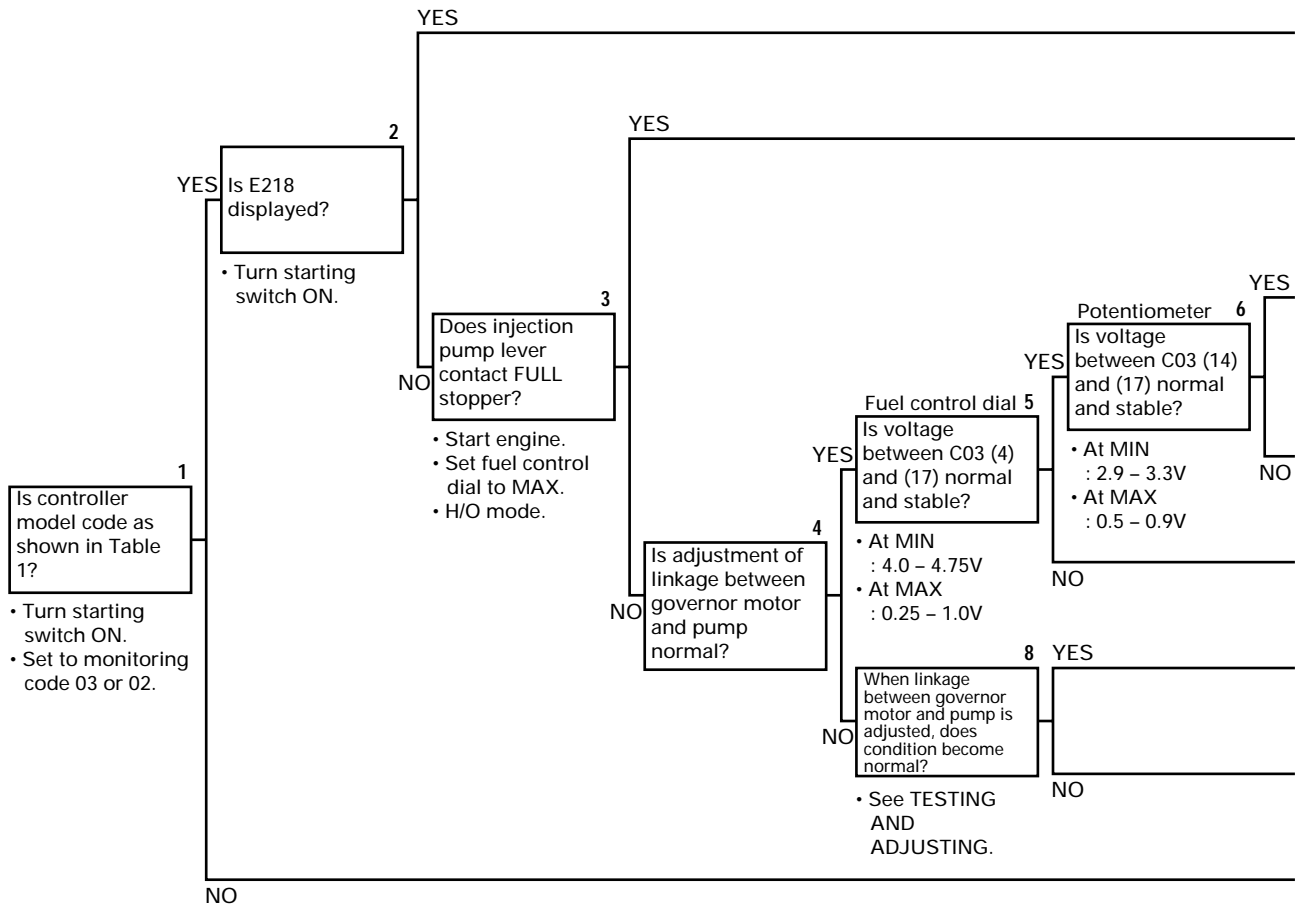

Table 1

Controller model code	
03	400
BKP00209	

- ★ The diagram shows monitoring code 03.

CLICK HERE TO **DOWNLOAD** THE COMPLETE MANUAL

- Thank you very much for reading the preview of the manual.
- You can download the complete manual from: www.heydownloads.com by clicking the link below



- Please note: If there is no response to CLICKING the link, please download this PDF first and then click on it.

CLICK HERE TO **DOWNLOAD** THE COMPLETE MANUAL

• **Example of troubleshooting when exhaust gas is black**

Let us assume that [Clogged air cleaner] is taken to be the cause of black exhaust gas. Three symptoms have causal relationship with this problem: [Exhaust gas slowly became black], [Power slowly became weaker], and [Dust indicator is red].

If we look from these three symptoms to find the causes, we find that there is a relationship with five causes. Let us explain here the method of using this causal relationship to pinpoint the most probable cause.

S-7 Exhaust gas is black (incomplete combustion)

General causes why exhaust gas is black

- Insufficient intake of air
- Improper condition of fuel injection
- Excessive injection of fuel

		Causes											
		Seized turbocharger, interference	Clogged air cleaner, interference	Worn piston ring, cylinder	Clogged, seized injection cylinder	Improper injection timing	Defective injection nozzle	Improper injection pump	Crushed, clogged muffer	Leakage of air between turbocharger and head	Defective contact of valve, valve seat	Defective injection pump, rack, plunger, plunger seized	
Questions	Confirm recent repair history												
	Degree of use			△	△						△		
	Color of exhaust gas	Suddenly became black	○										○
		Gradually became black	◎										
		Blue under light load											
	Engine oil must be added more frequently		◎										
	Power was lost	Suddenly	◎										○
		Gradually		○	○						○	○	
	Non-specified fuel has been used												○
	Noise of interference is heard from around turbocharger		◎										
Dust indicator is red		◎											
Check items	Blow-by gas is excessive		◎										
	Engine pickup is poor and combustion is irregular	○			◎			○	○	○		○	
	When exhaust manifold is touched immediately after starting engine, temperature of some cylinders is low				◎							○	
	Match marks on fuel injection pump are out of alignment					◎							
	Seal on injection pump has come off						◎						
	Clanging sound is heard from around cylinder head						◎						
	Exhaust noise is abnormal	○			○				◎				
	Muffler is crushed								◎				
	Leakage of air between turbocharger and head, loose clamp									◎			
	Troubleshooting	When turbocharger is rotated by hand, it is found to be heavy	●										
When air cleaner is inspected directly, it is found to be clogged			●										
When compression pressure is measured, it is found to be low				●							●		
Speed of some cylinders does not change when operating on reduced cylinders					●								
When check is made using delivery method, injection timing is found to be incorrect						●							
Injection pump test shows that injection amount is incorrect							●						
When valve clearance is checked directly it is found to be outside standard value								●					
When muffler is removed, exhaust gas color returns to normal									●				
When control rack is pushed, it is found to be heavy or does not return											●		
Remedy	Replace	Clean	Replace	Replace	Adjust	Adjust	Adjust	Repair	Replace	Replace	Replace		

S-7 Exhaust smoke is black (incomplete combustion)

General causes why exhaust smoke is black

- Insufficient intake of air
- Improper condition of fuel injection
- Excessive injection of fuel

Legend

- : Possible causes (judging from Questions and check items)
- ⊙: Most probable causes (judging from Questions and Check items)
- △: Possible causes due to length of use (used for a long period)
- : Items to confirm the cause.

Causes	
Seized turbocharger, interference	
Clogged air cleaner element	
Worn piston ring, cylinder liner	
Clogged injection nozzle, defective spray	
Improper injection timing	
Defective injection pump	
Improper valve clearance (excessive injection)	
Crushed, clogged muffler	
Leakage of air between turbocharger and head	
Defective contact of valve and valve seat	
Defective injection pump (rack, plunger seized)	

Questions		Causes												
Confirm recent repair history														
Degree of use of machine	Operated for long period		△	△	△								△	
Color of exhaust gas	Suddenly became black	⊙												○
	Gradually became black		⊙									○		
	Blue under light load			⊙										
Engine oil must be added more frequently				⊙										
Power was lost	Suddenly	⊙			○					○				○
	Gradually		○	○							○	○		
Non-specified fuel is being used					○									○
Noise of interference is heard from around turbocharger		⊙												
Air cleaner clogging caution lamp flashes			⊙											
Blow-by gas is excessive				⊙										
Engine pickup is poor and combustion is irregular		○			⊙				○	○	○			○
When exhaust manifold is touched immediately after starting engine, temperature of some cylinders is low					⊙									○
Match marks on fuel injection pump are out of alignment							⊙							
Seal on injection pump has come off								⊙						
Clanging sound is heard from around cylinder head									⊙					
Exhaust noise is abnormal		○			○					⊙				
Muffler is crushed										⊙				
Leakage of air between turbocharger and head, loose clamp											⊙			

Troubleshooting		Causes												
When turbocharger is rotated by hand, it is found to be heavy		●												
When air cleaner is inspected directly, it is found to be clogged			●											
When compression pressure is measured, it is found to be low				●								●		
Speed does not change when operation of certain cylinders is stopped					●									
When check is made using delivery method, injection timing is found to be incorrect						●								
Injection pump test shows that injection amount is incorrect							●							
When valve clearance is checked directly it is found to be outside standard value								●						
When muffler is removed, exhaust color returns to normal									●					
When control rack is pushed, it is found to be heavy, or does not return													●	

Remedy	1	2	3	4	5	6	7	8	9	10	11	12	13	14
Replace														
Clean														
Replace														
Replace														
Adjust														
Adjust														
Adjust														
Replace														
Correct														
Replace														
Replace														

User code	Service code	Abnormal system	Nature of abnormality
—	E231	Short circuit in active mode (swing) solenoid system	<ol style="list-style-type: none"> 1. Short circuit with ground, short circuit inside active mode (swing) solenoid 2. Short circuit with ground in wiring harness between controller C01 (10) and solenoid V07 (2) ((+) side) 3. Defective governor, pump controller
—	E234	Abnormality in overload caution pressure sensor system	<ol style="list-style-type: none"> 1. Disconnection, defective contact, short circuit, short circuit with ground inside overload caution pressure sensor. 2. Disconnection, defective contact, short circuit in wiring harness between controller C03 (6) and pressure sensor M52 (2) ((+) side) and between C03 (16) and M52 (1) ((-) side) 3. Disconnection, defective contact, short circuit with power source, short circuit with ground in wiring harness between controller C03 (5) and pressure sensor M52 (3) (SIG side) 4. Defective governor, pump controller
—	E235	Disconnection in active mode (swing) solenoid system	<ol style="list-style-type: none"> 1. Disconnection, defective contact inside active mode (swing) solenoid 2. Disconnection, defective contact, short circuit with power source in wiring harness between controller C01 (10) and solenoid V07 (2) ((+) side) 3. Disconnection, defective contact in wiring harness between solenoid V07 (1) and chassis ground ((-) side) 4. Defective governor, pump controller

C-3 Related electric circuit diagram

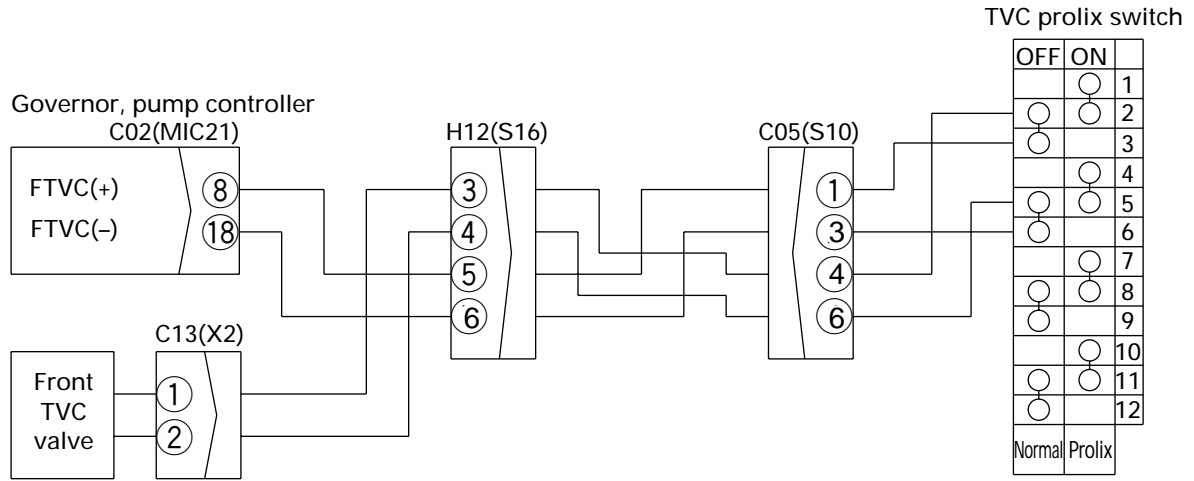

BKP00187

C-9 Related electric circuit diagram

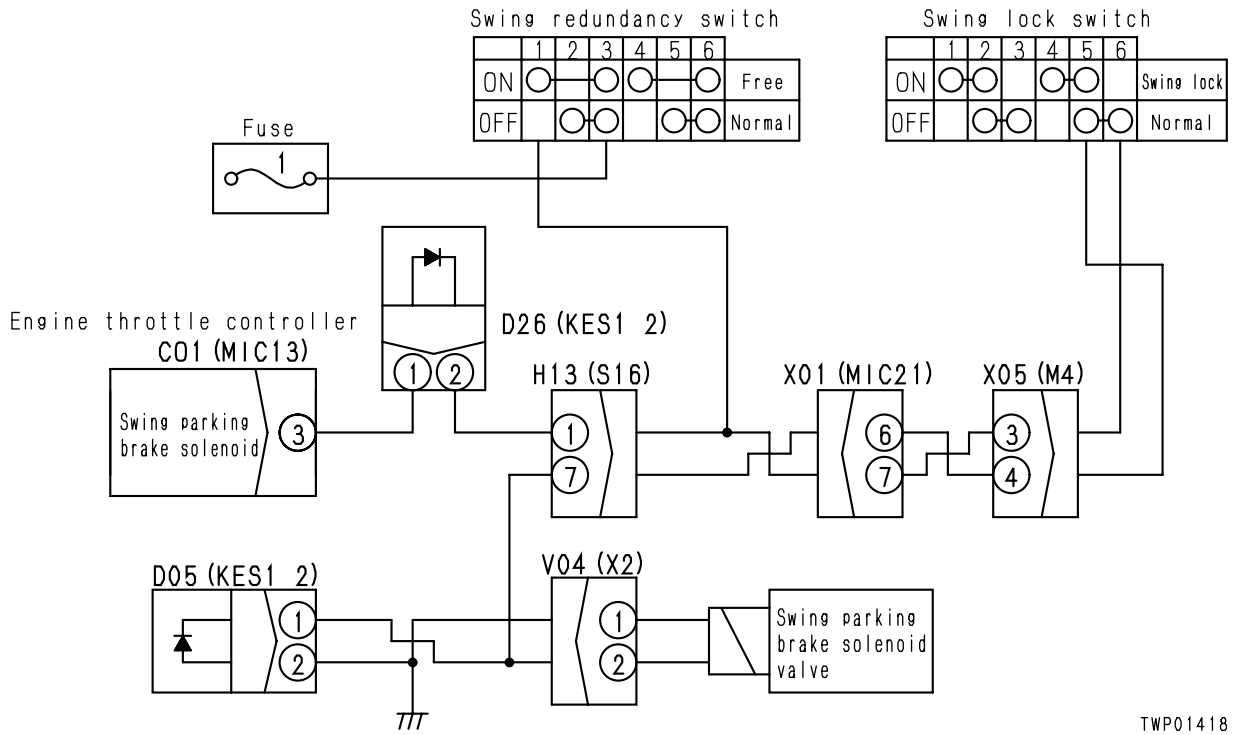

TWP01418

C-18 [E223] Disconnection in LS-EPC solenoid system is displayed

- ★ This troubleshooting is carried out when there is still an abnormality, so when disconnecting the connector and inserting the T-adapter, or when removing the T-adapter and returning the connector to its original position, if an E service code is not displayed, the problem has been removed.
- ★ If the starting switch is turned OFF after an abnormality occurs, turn the starting switch ON and check if an E service code is displayed. (If it is not displayed, the problem has been removed.)
- ★ Before carrying out troubleshooting, check that all the related connectors are properly inserted.
- ★ Always connect any disconnected connectors before going on the next step.

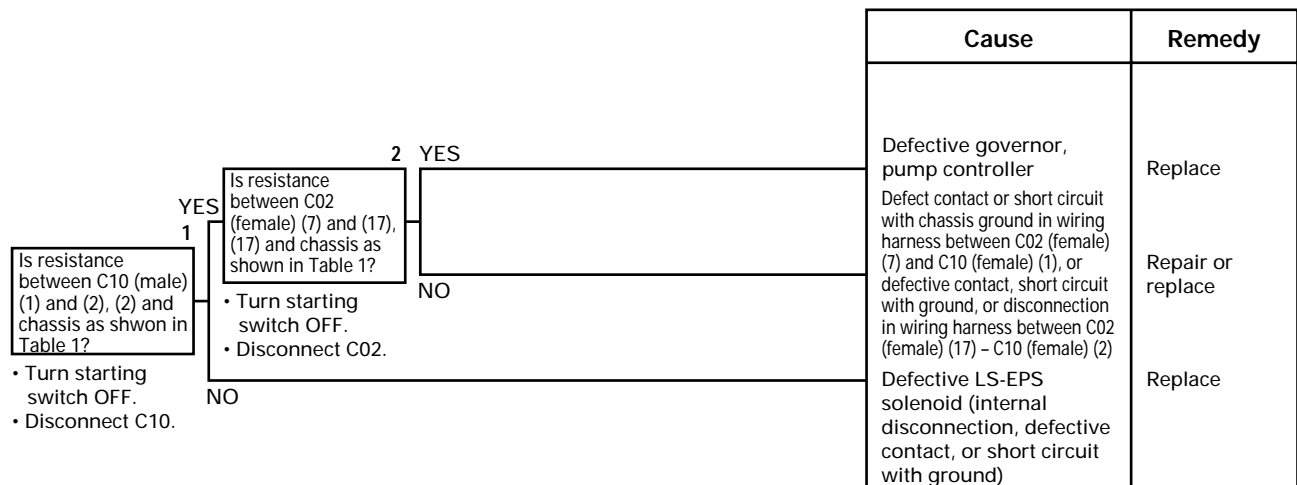
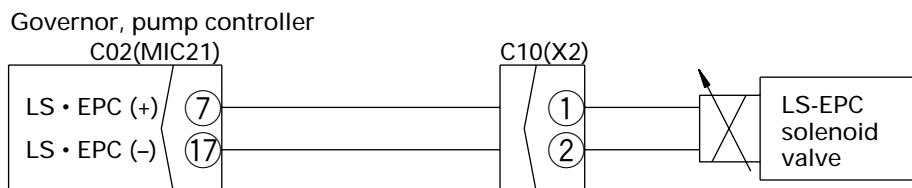

Table 1

Troubleshooting No. 1	Troubleshooting No. 2	Resistance value
Between C10 (male) (1) - (2)	Between C02 (female) (7) - (17)	7 - 14 Ω
Between C10 (male) (2) - chassis	Between C02 (female) (17) - chassis	Min. 1 MΩ

C-18 Related electric circuit diagram



BKP00251

ELECTRICAL CIRCUIT DIAGRAM FOR F MODE

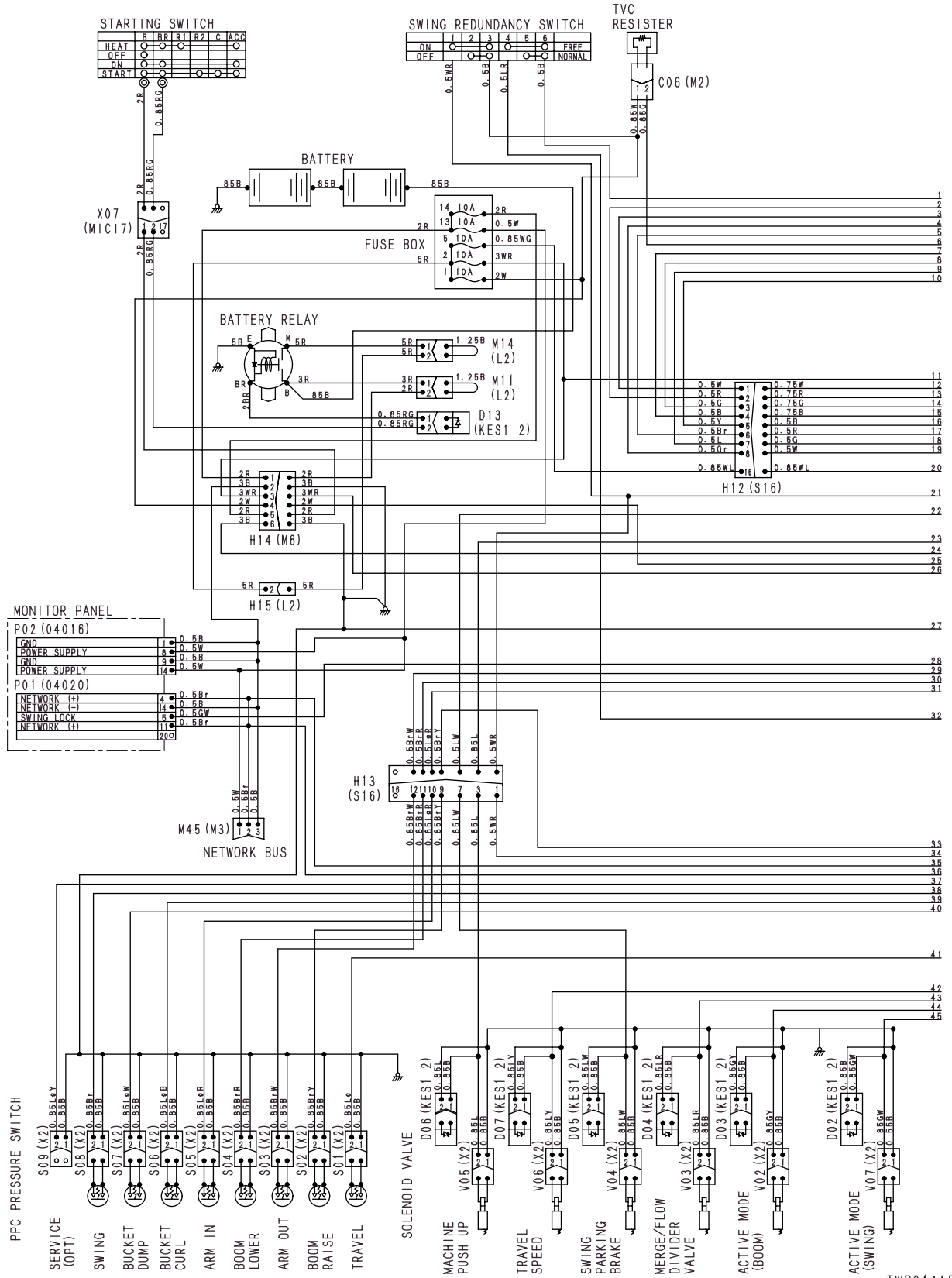

TWP01415

F-9 Bit pattern 21-(3) (Swing lock switch) does not light up

- ★ This troubleshooting is carried out when there is still an abnormality, so when disconnecting the connector and inserting the T-adapter, or when removing the T-adapter and returning the connector to its original position, if the monitor code display returns to normal, the problem has been removed.
- ★ If the panel display is normal. (If the swing lock lamp does not light up, go to M-21.)
- ★ Before carrying out troubleshooting, check that all the related connectors are properly inserted.
- ★ Always connect any disconnected connectors before going on the next step.

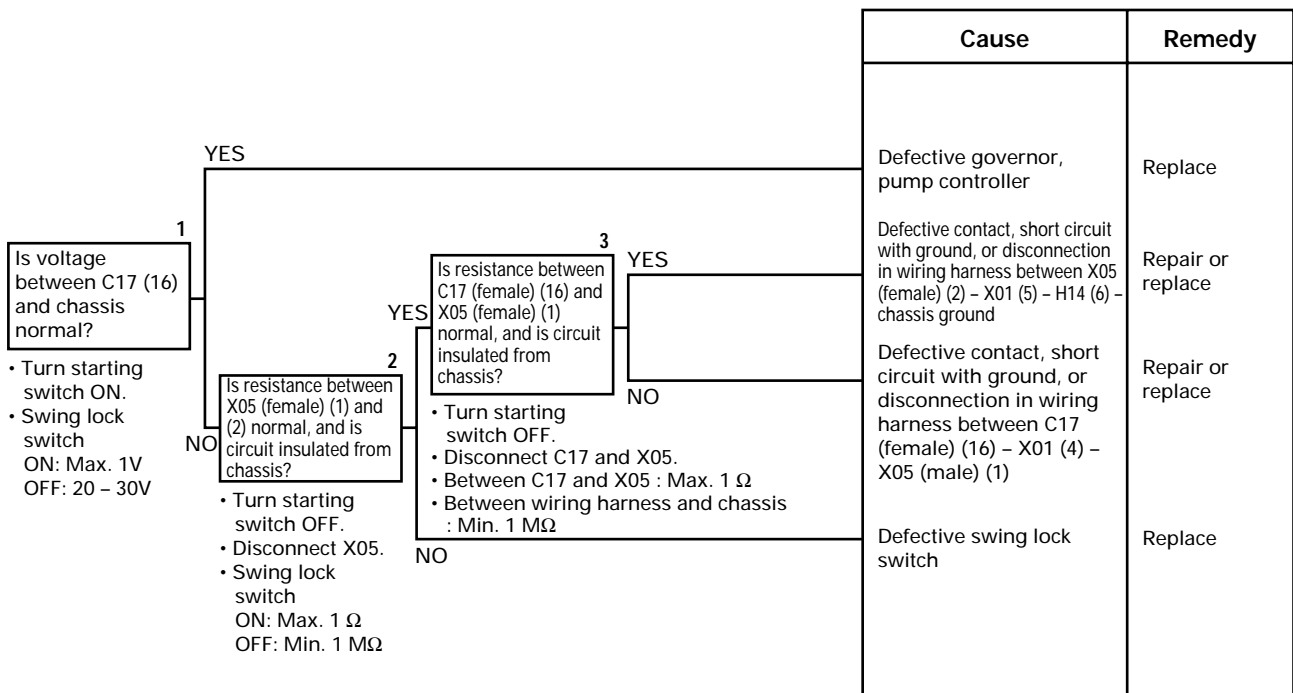

F-9 Related electric circuit diagram

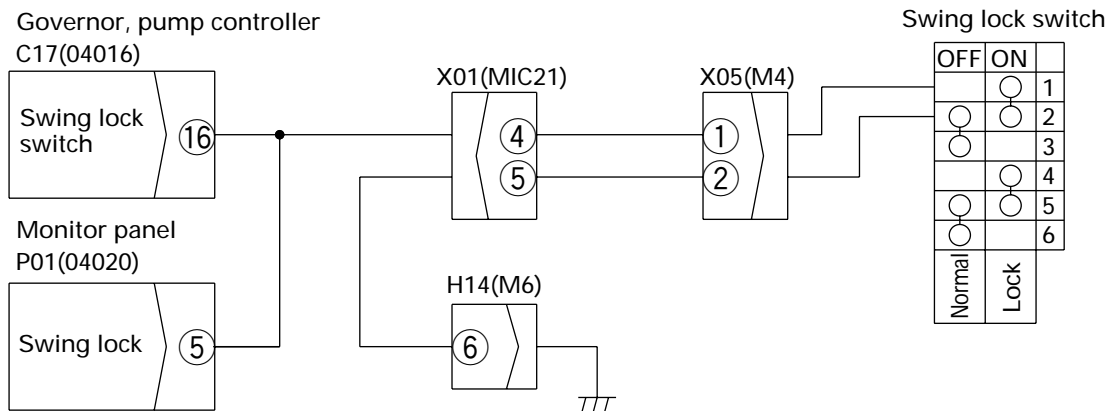

BKP00265

H-1 Speeds of all work equipment, swing, travel are slow or lack power

- ★ Carry out troubleshooting in the H/O mode.
- ★ Check that no abnormal noise is being generated from the main pump before carrying out troubleshooting. (If there is any abnormal noise, carry out troubleshooting for H-4.)

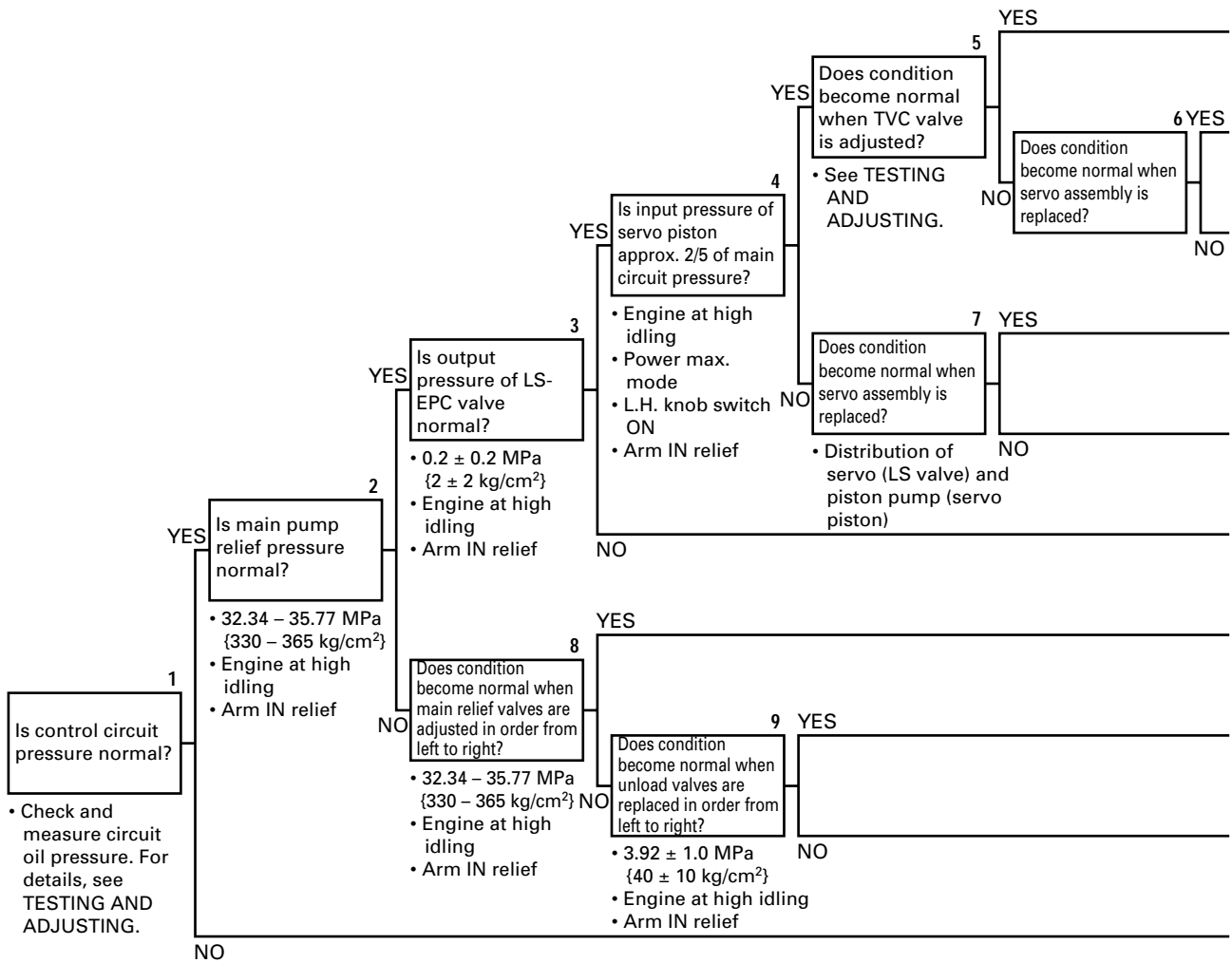

※ The oil pressure in the control circuit is reduced by the self-pressure reducing valve.

- ★ Measuring servo piston inlet port pressure in Item No. 4
 - Measure the input pressure to the large diameter end of the servo piston when the arm is relieved in the power max. mode. (Approx. 12.74 MPa {130 kg/cm²})
 Basically, the pressure at the large diameter end is approx. 2/5 of the small diameter end. (For details, see TESTING AND ADJUSTING.)

H-9 Bucket is slow or lacks power

★ When travel and swing speeds are normal.

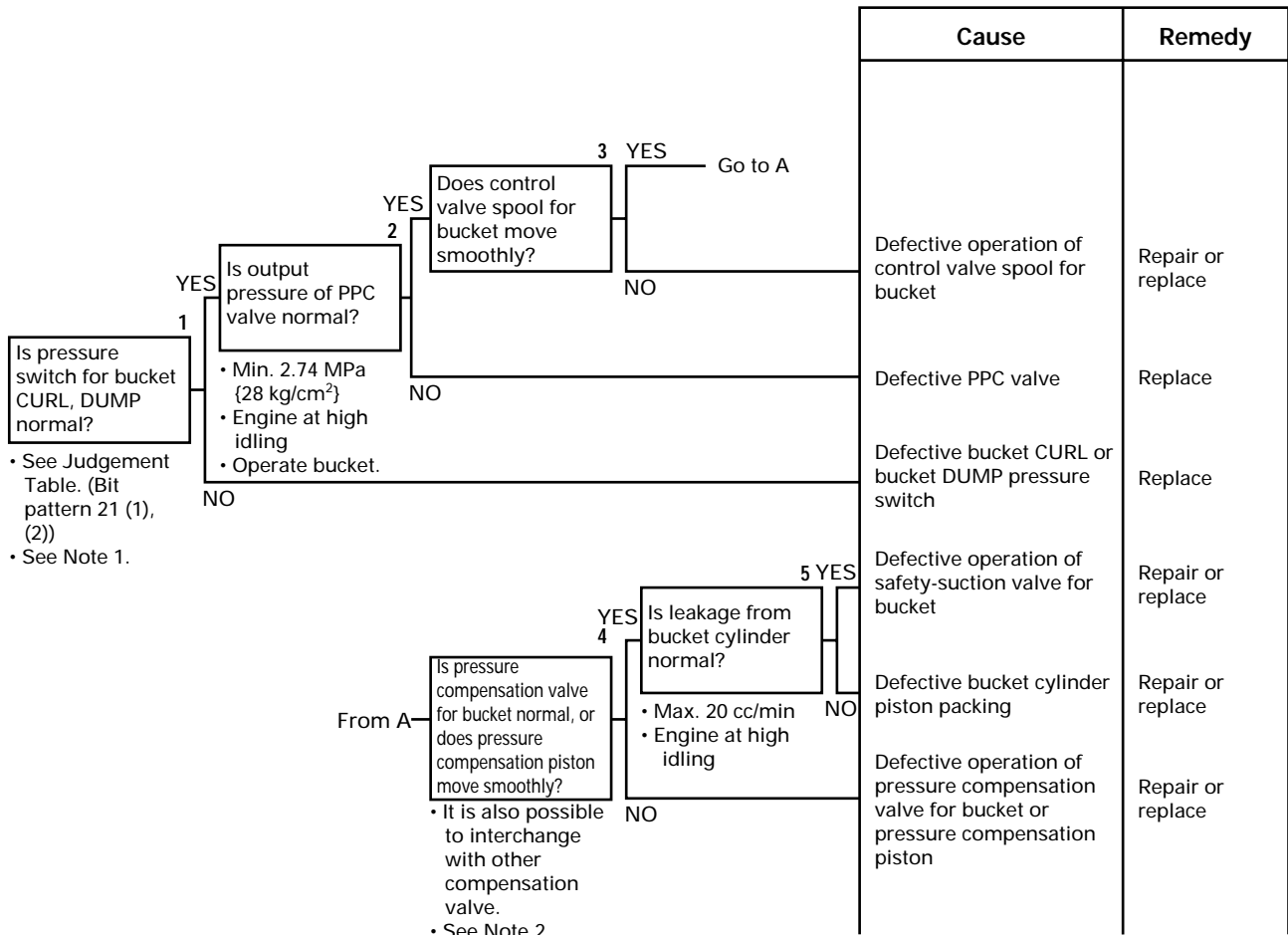

Note 1: If the auto-deceleration is canceled when bucket CURL or bucket DUMP is operated, the system is normal.

Note 2: After inspection, do not forget to return the interchanged valves to the original position.

H-23 Travel speed does not switch or is faster than specified speed

★ Carry out troubleshooting in the H/O mode.

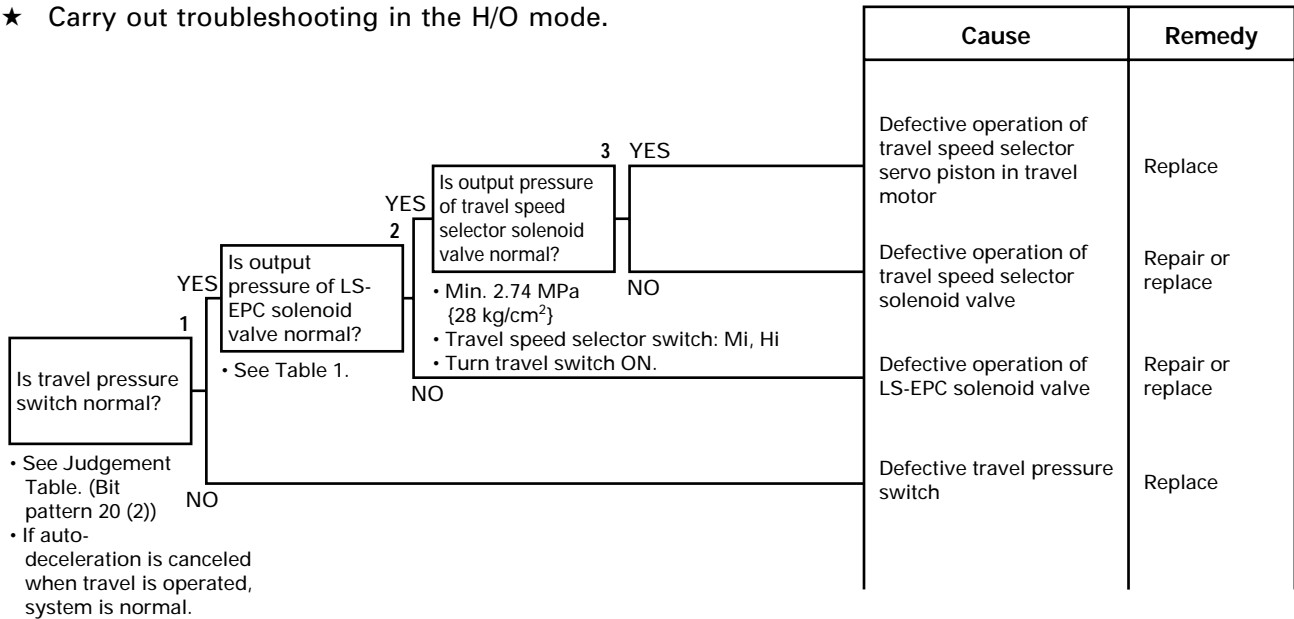
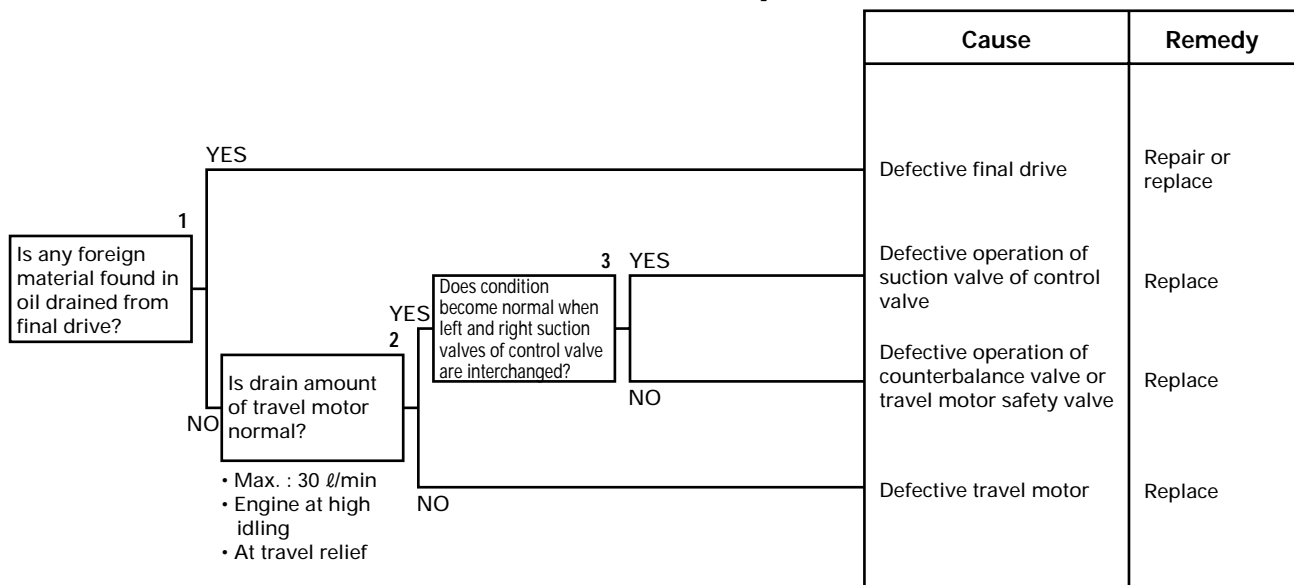

Table 1. Output pressure of LS-EPC solenoid

Unit: MPa {kg/cm²}

Travel speed	Lo	Mi	Hi
LS-EPC output pressure	0.2 ± 0.2 {2.0 ± 2.0}	1.8 ± 0.2 {18.4 ± 2.0}	0.2 ± 0.2 {2.0 ± 2.0}
Remarks	<ul style="list-style-type: none"> • Engine at high idling • Operate travel lever slightly (auto-deceleration cancel position) 		

H-24 Travel does not move (one side only)



M-14	When starting switch is turned ON (engine stopped), buzzer does not sound for 1 second Caution item flashes but buzzer does not sound	20-626
M-15	No abnormality is displayed on monitor but buzzer sounds	20-626
M-16	Night lighting on monitor panel does not light up (liquid crystal display is normal) ...	20-627
M-17	Coolant temperature gauge does not rise	20-628
M-18	Coolant temperature gauge does not give any display	20-628
M-19	Fuel level gauge always displays FULL	20-629
M-20	Fuel level gauge does not give display	20-629
M-21	Swing lock switch is turned ON (LOCK) but (swing lock monitor) does not light up....	20-630
M-22	Swing prolix switch is turned ON (prolix), but (swing lock monitor) does not flash	20-630
M-23	Service meter does not advance while engine is running	20-631
M-24	When starting switch is at OFF and time switch is pressed, time and service meter are not displayed.....	20-631
M-25	Defective fuel level sensor system	20-632
M-26	Defective coolant temperature sensor system	20-633
M-27	Defective engine oil level sensor system	20-634
M-28	Defective coolant level sensor system	20-635
M-29	Defective hydraulic oil level sensor system	20-636
M-30	Wiper does not work or switch is not being used but wiper is actuated (include E112, E113)	20-638
	a) Wiper does not work	20-638
	b) Wiper switch is not being operated but wiper is actuated	20-642
M-31	Washer motor does not work, or switch is not being used but washer motor is actuated (include E114)	20-643
	a) Washer motor does not work	20-643
	b) Switch is not being operated but washer is actuated	20-644

M-6 When starting switch is turned ON, none of lamps on monitor panel light up for 3 seconds

- ★ Check that fuses No. 10 and 13 are not blown.
- ★ Before carrying out troubleshooting, check that all the related connectors are properly inserted.
- ★ Always connect any disconnected connectors before going on the next step.

a) None of lamps on monitor panel light up

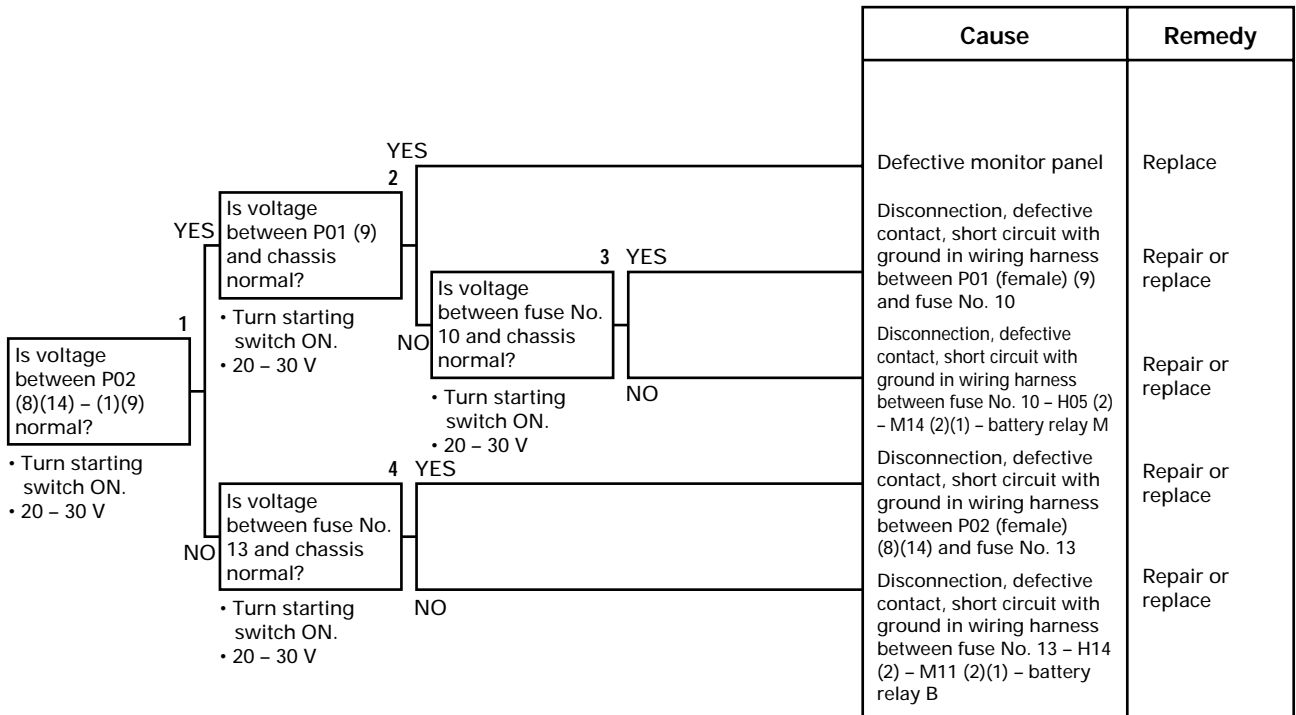

b) Some of lamps on monitor panel do not light up

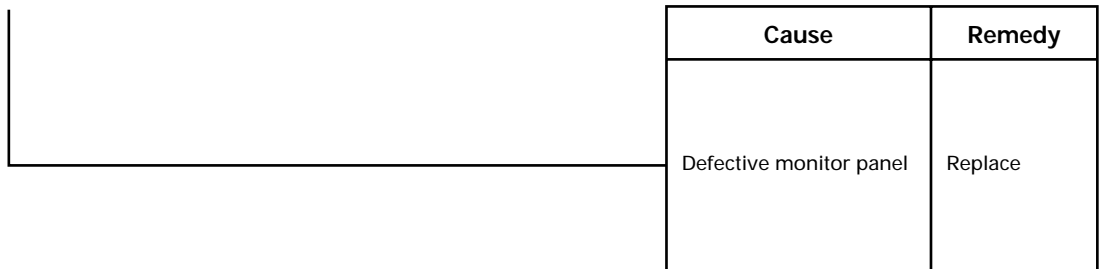

b) Engine oil pressure sensor system

★ When engine oil pressure is normal.

1) Low-pressure sensor

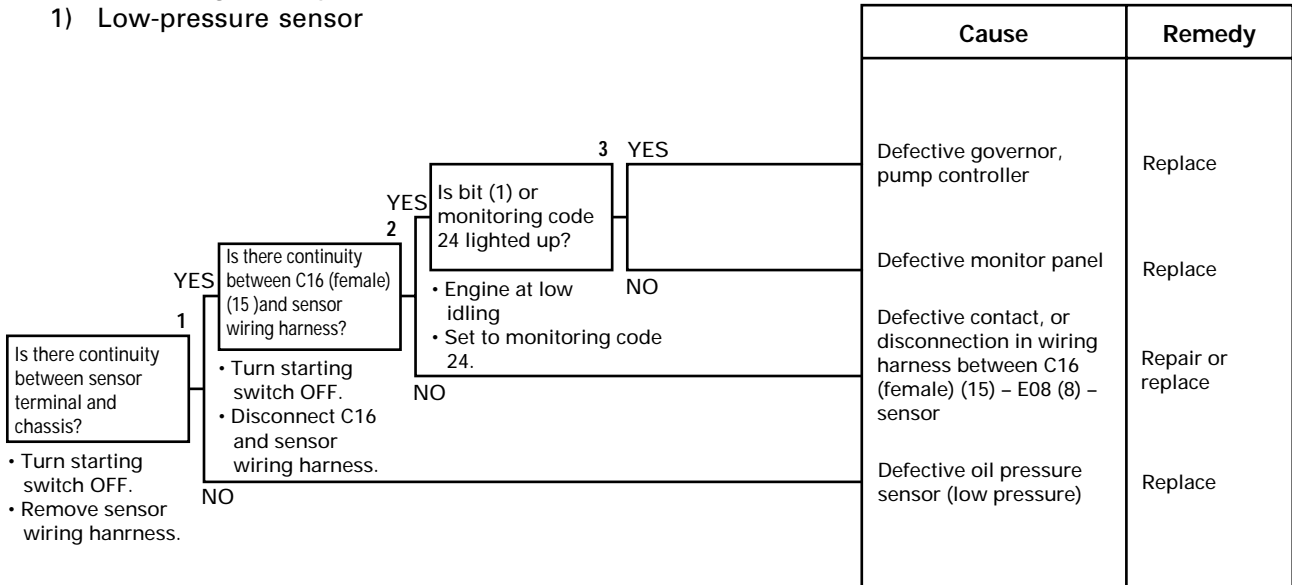

2) High-pressure sensor

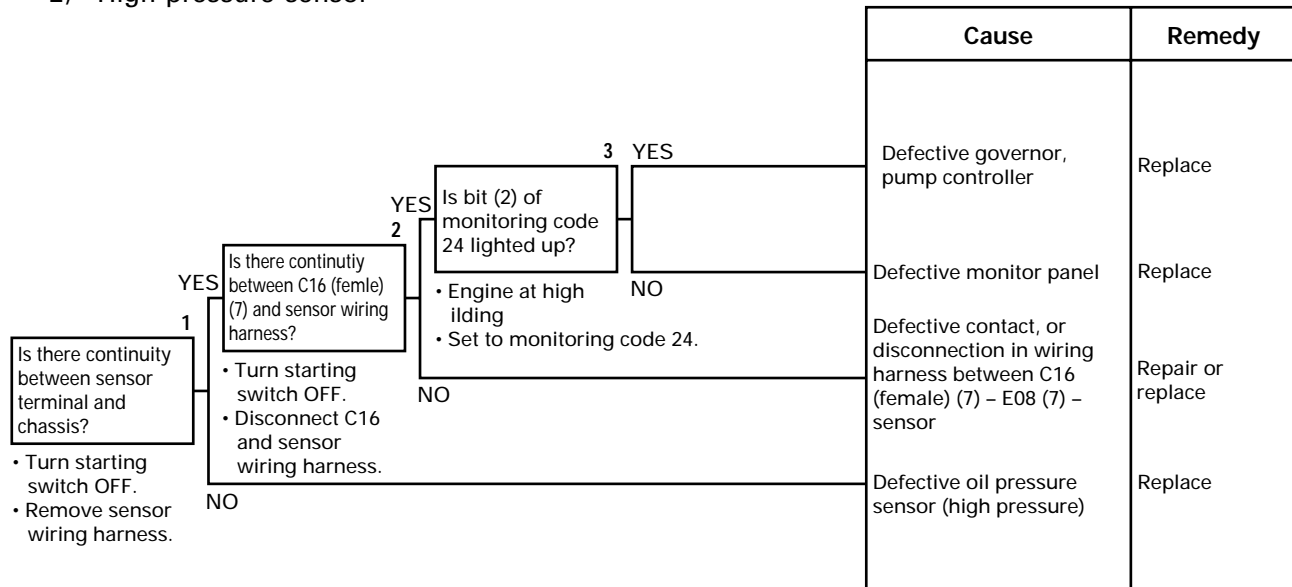

M-12 b) Related electric circuit diagram

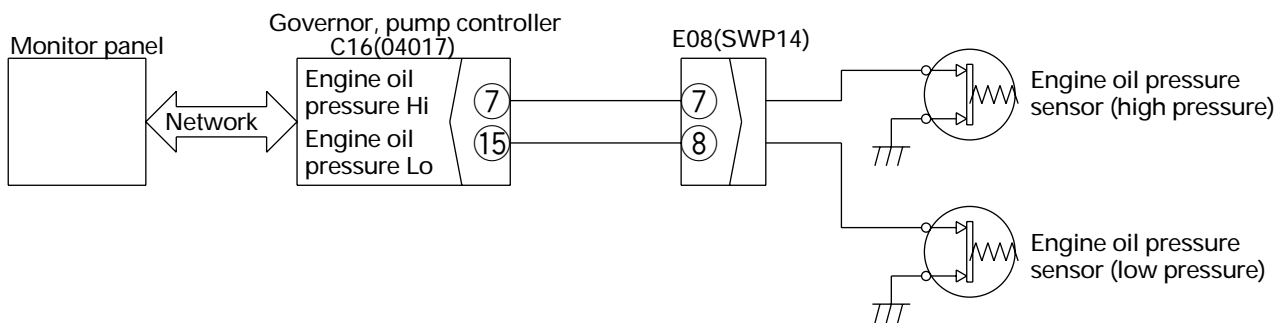

BKP00283

M-25 Defective fuel level sensor system

★ Remove the fuel level sensor when carrying out the troubleshooting.

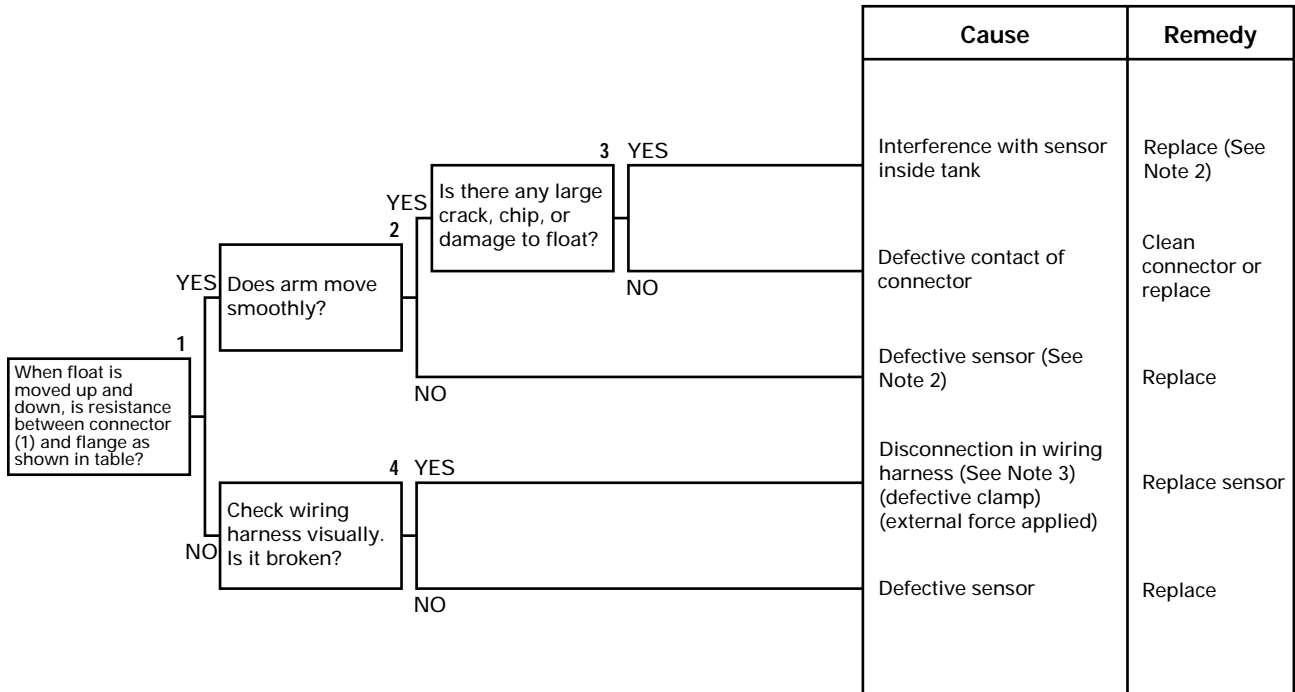

Table

Top (FULL) stopper position	Approx. 12 Ω or below
Bottom (EMPTY) stopper position	Approx. 85 – 110 Ω

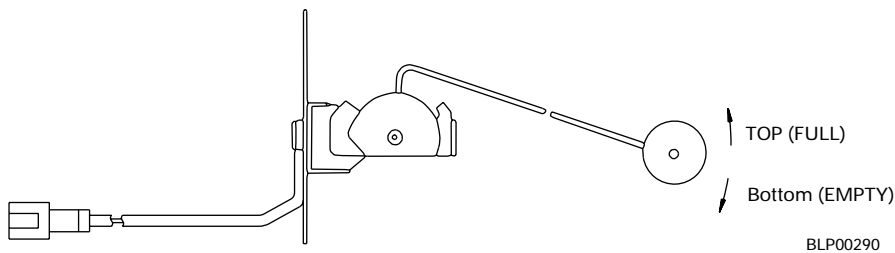

Note 1: Difference between fuel level and gauge display

For gauge display position 14 (FULL), the amount of fuel is 78-100%; and for display position 1 (EMPTY) it is below 14.5%. If the chassis is at an angle, the displayed amount of fuel will be different from the actual amount. Therefore, when checking, stop the machine at a horizontal place and wait for at least 2 minutes before checking the gauge. (The display is given a time delay so that the gauge can deal with sudden changes in the fuel level.)

Note 2: There is the possibility of defective installation or interference with the sensor inside the tank, so be careful when installing.

Note 3: Check for vibration at the connector mount. If there is excessive vibration, take the appropriate action.

b) Wiper switch is not being operated but wiper is actuated

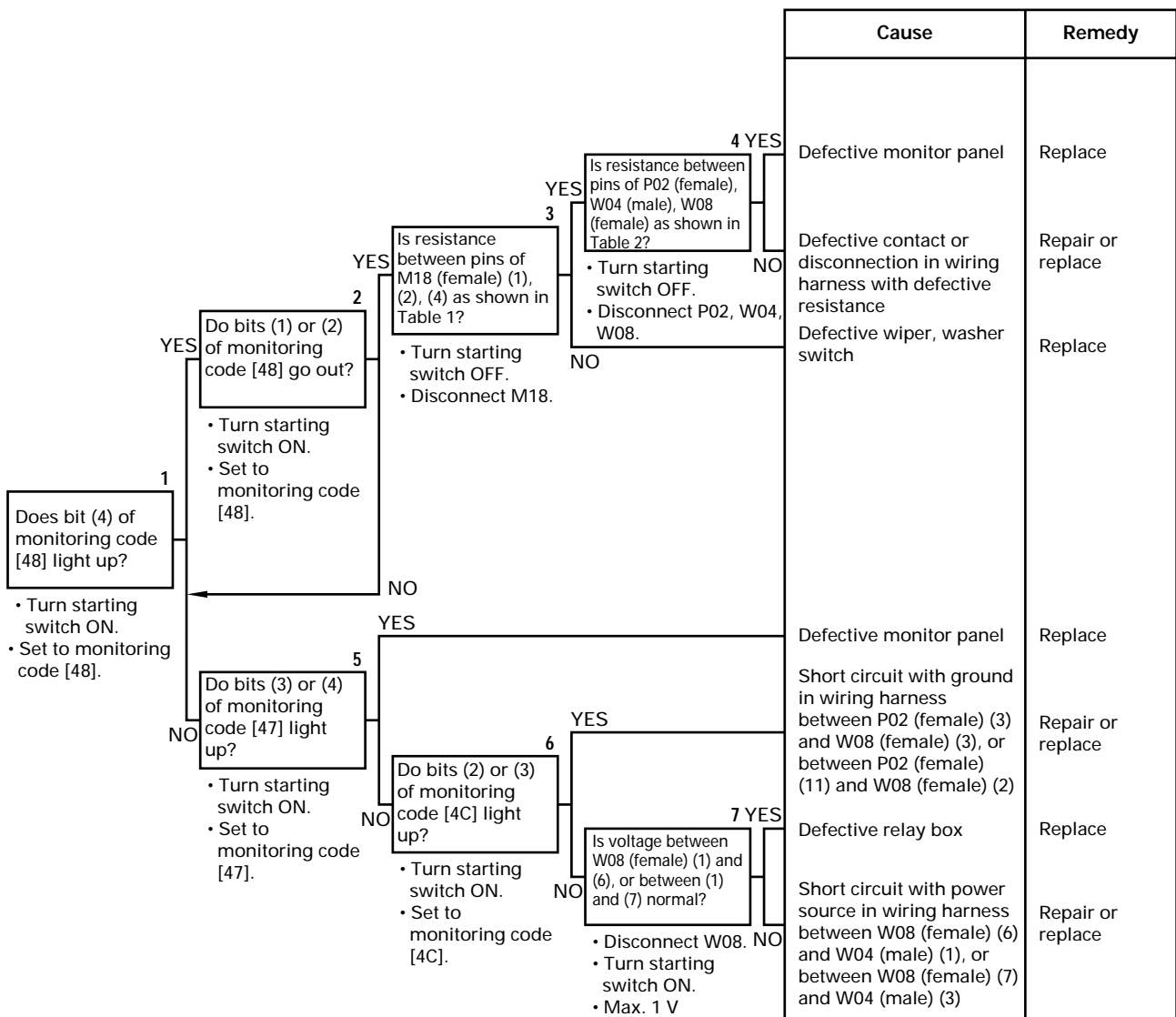

Table 2

	Resistance value
Between W04 (female) (1) and W08 (female) (6) [(7)]	Max. 1 Ω
Between W04 (female) (3) and W08 (female) (7) [(6)]	
Between W04 (female) (4) and P02 (female) (5)	
Between W04 (female) (5) and P02 (female) (1)	
Between W04 (female) (6) and P02 (female) (6)	
Between W04 (female) (1),(3),(4),(5),(6) and GND	Min. 1 MΩ
Between W08 (female) (17) [(2)] and P02 (female) (11)	Max. 1 Ω
Between W08 (female) (18) [(3)] and P02 (female) (3)	

[]: For machines with power window specification

Table 3

Wiper switch	M18 (female)	P02 (female)	Resistance
INT mode	Between (1) – (2)	Between (1) – (4)	Min. 1 MΩ
	Between (1) – (4)	Between (1) – (12)	Max. 1 Ω
	Between (2) – (4)	Between (4) – (12)	Min. 1 MΩ
OFF mode	Between (1) – (2)	Between (1) – (4)	Min. 1 MΩ
	Between (1) – (4)	Between (1) – (12)	
	Between (2) – (4)	Between (4) – (12)	
ON mode	Between (1) – (2)	Between (1) – (4)	Max. 1 Ω
	Between (1) – (4)	Between (1) – (12)	Min. 1 MΩ
	Between (2) – (4)	Between (4) – (12)	

PRECAUTIONS WHEN CARRYING OUT OPERATION

[When carrying out removal or installation (disassembly or assembly) of units, be sure to follow the general precautions given below when carrying out the operation.]

1. Precautions when carrying out removal work

- If the coolant contains antifreeze, dispose of it correctly.
- After disconnecting hoses or tubes, cover them or fit blind plugs to prevent dirt or dust from entering.
- When draining oil, prepare a container of adequate size to catch the oil.
- Confirm the match marks showing the installation position, and make match marks in the necessary places before removal to prevent any mistake when assembling.
- To prevent any excessive force from being applied to the wiring, always hold the connectors when disconnecting the connectors. Do not pull the wires.
- Fit wires and hoses with tags to show their installation position to prevent any mistake when installing.
- Check the number and thickness of the shims, and keep in a safe place.
- When raising components, be sure to use lifting equipment of ample strength.
- When using forcing screws to remove any components, tighten the forcing screws uniformly in turn.
- Before removing any unit, clean the surrounding area and fit a cover to prevent any dust or dirt from entering after removal.

★ Precautions when handling piping during disassembly

Fit the following blind plugs into the piping after disconnecting it during disassembly operations.

1) Hoses and tubes using sleeve nuts

Nominal number	Plug (nut end)	Sleeve nut (elbow end) Use the two items below as a set
02	07376-50210	07221-20210 (Nut), 07222-00210 (Plug)
03	07376-50315	07221-20315 (Nut), 07222-00312 (Plug)
04	07376-50422	07221-20422 (Nut), 07222-00414 (Plug)
05	07376-50522	07221-20522 (Nut), 07222-00515 (Plug)
06	07376-50628	07221-20628 (Nut), 07222-00616 (Plug)
10	07376-51034	07221-21034 (Nut), 07222-01018 (Plug)
12	07376-51234	07221-21234 (Nut), 07222-01219 (Plug)

2) Split flange type hoses and tubes

Nominal number	Flange (hose end)	Sleeve head (tube end)	Split flange
04	07379-00400	07378-10400	07371-30400
05	07379-00500	07378-10500	07371-30500

3) If the part is not under hydraulic pressure, the following corks can be used.

Nominal number	Part Number	Dimensions		
		D	d	L
06	07049-00608	6	5	8
08	07049-00811	8	6.5	11
10	07049-01012	10	8.5	12
12	07049-01215	12	10	15
14	07049-01418	14	11.5	18
16	07049-01620	16	13.5	20
18	07049-01822	18	15	22
20	07049-02025	20	17	25
22	07049-02228	22	18.5	28
24	07049-02430	24	20	30
27	07049-02734	27	22.5	34

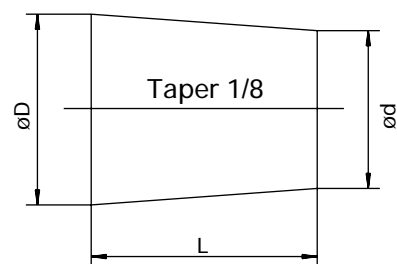

DEW00401

S32-1 Guide

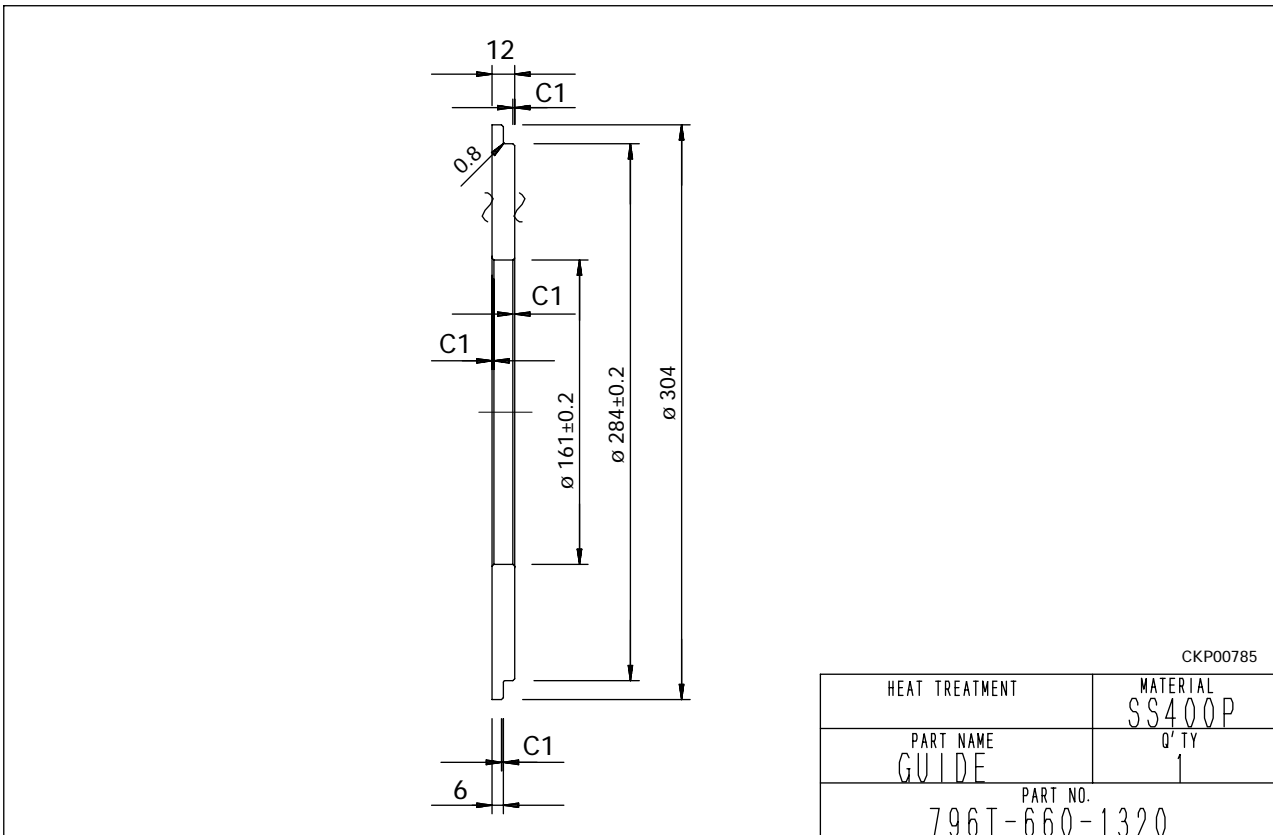

S32-3-1 Plate

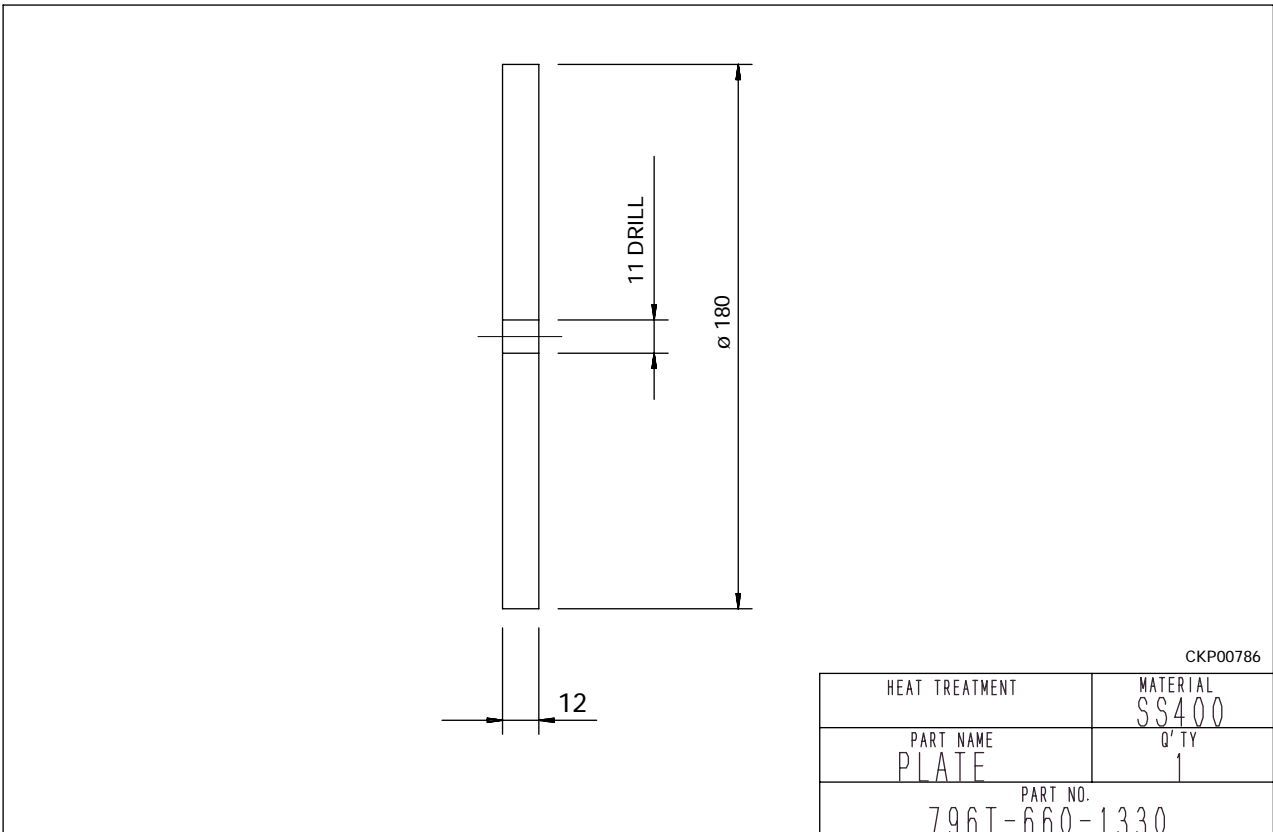

REMOVAL OF NOZZLE HOLDER ASSEMBLY

1. Open engine hood.
2. Remove spill tube (1).
3. Disconnect delivery tube (2) of nozzle holder to be removed. ※ 1
4. Remove nozzle holder assembly (3). ※ 2

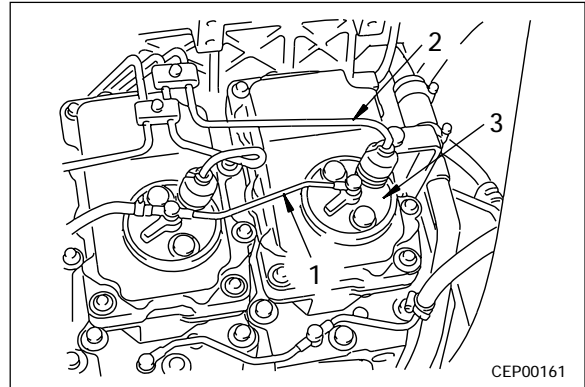

INSTALLATION OF NOZZLE HOLDER ASSEMBLY

- Carry out installation in the reverse order to removal.

※ 1

 Delivery tube mounting sleeve nut:
 $23.6 \pm 1.0 \text{ Nm}$ { $2.4 \pm 0.1 \text{ kgm}$ }

※ 2

 Coat the thread of the nozzle holder mounting bolt with **EO-30CD**.

★ Tighten the nozzle holder mounting bolts uniformly in turn.

 Nozzle holder mounting bolt:
 $24.5 \pm 4.9 \text{ Nm}$ { $2.5 \pm 0.5 \text{ kgm}$ }

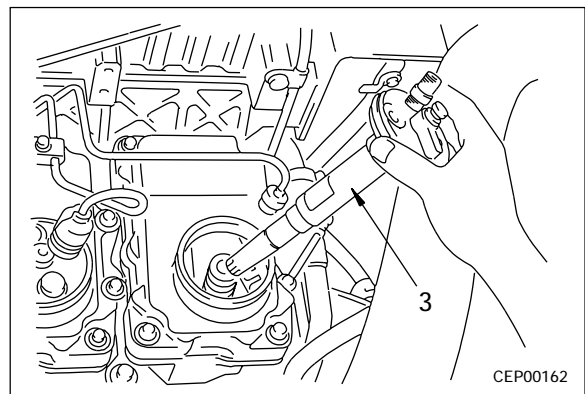

10. Remove clamps (18) and (19) of delivery tubes (17). ※ 5

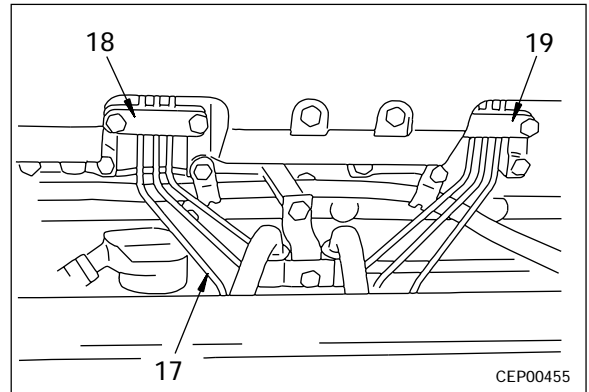

11. Remove 6 delivery tubes (17), then remove boost compensation tube (20). ※ 6

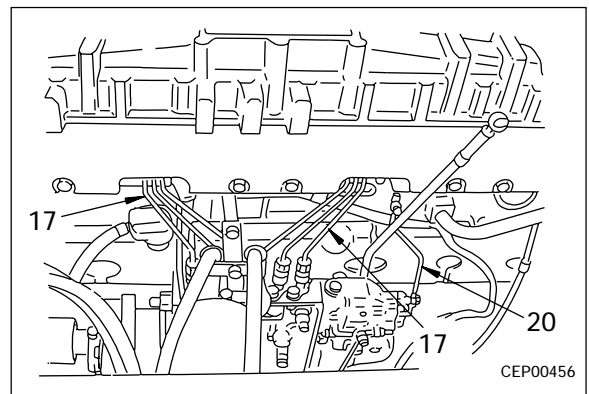

12. Disconnect heater wiring (21), and remove aftercooler assembly (22) and 6 electrical intake air heaters (23).

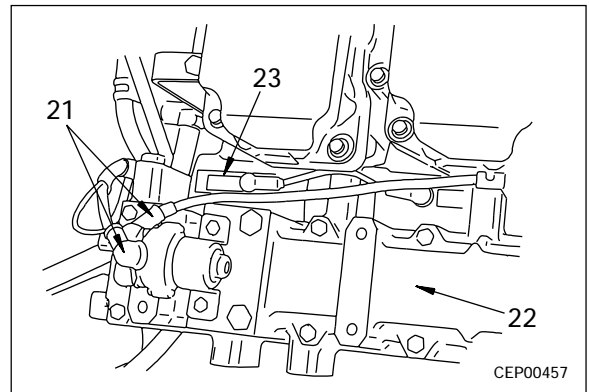

13. Remove aeration tube (24) and spill tube (25).

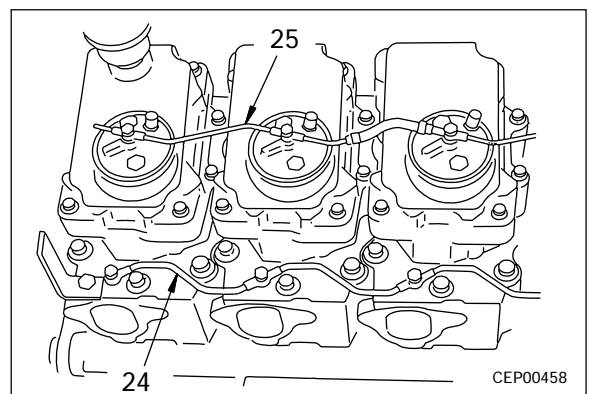

6. Disconnect cooler inlet tube (8).

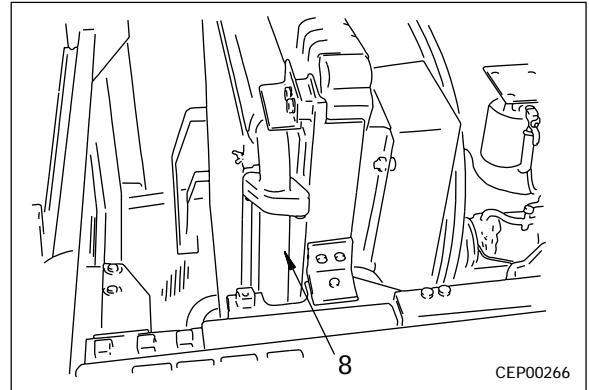

7. Sling hydraulic cooler assembly (9), remove mounting bolts (bottom: left and right; top: left and right), then lift off hydraulic cooler assembly (9).



Hydraulic cooler assembly: **110 kg**

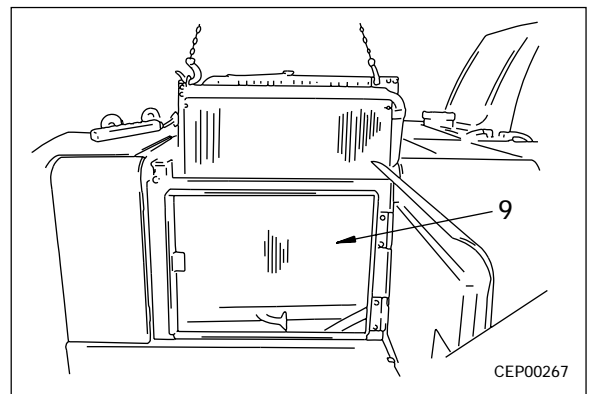

INSTALLATION OF HYDRAULIC COOLER ASSEMBLY

- Carry out installation in the reverse order to removal.
- **Refilling with oil (hydraulic tank)**
 - ★ Add oil through the oil filler to the specified level.
Run the engine to circulate the oil through the system. Then check the oil level again.

REMOVAL OF CENTER SWIVEL JOINT ASSEMBLY

PC400-6 Serial No.: 32001 – 32249

PC450-6 Serial No.: 12001 – 12143

⚠ Release the remaining pressure in the hydraulic circuit.

For details, see TESTING AND ADJUSTING, Releasing remaining pressure from hydraulic circuit.

⚠ Loosen the hydraulic tank oil filler cap slowly to release the pressure inside the hydraulic tank.

★ Mark all the piping with tags to prevent mistakes in the mounting position when installing.

1. Disconnect travel motor hoses (1) and (2).
2. Disconnect speed selector hose (3).
3. Disconnect drain hose (4), and remove elbow (5).
 - ★ Install a blind plug in the drain hose.
4. Disconnect drain hoses (7) and (8).
 - ★ Install a blind plug in the drain hose.
5. Disconnect travel hoses (9) and (10), and speed selector hose (11).
6. Pull out pin (12), and disconnect plate (13).
7. Sling center swivel joint assembly (14), remove mounting bolts from below, then lift off.



Center swivel joint assembly: **40 kg**

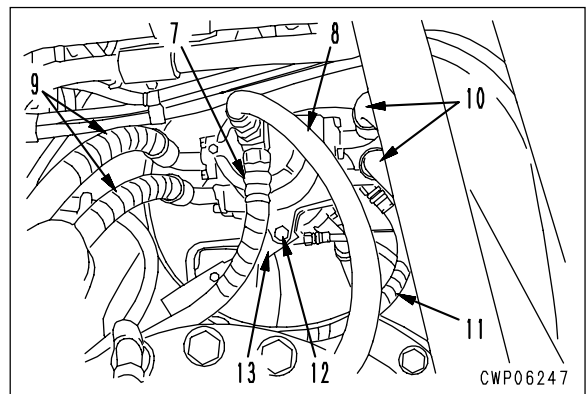
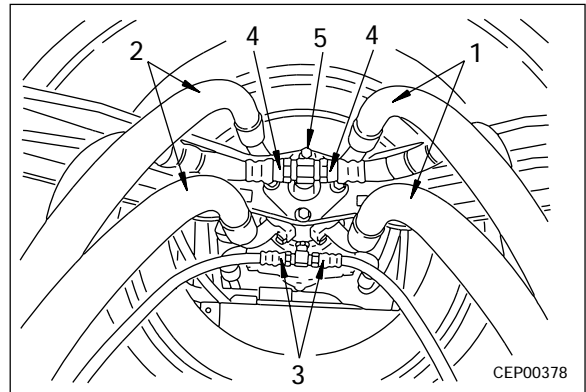

INSTALLATION OF CENTER SWIVEL JOINT ASSEMBLY

PC400-6 Serial No.: 32001 – 32249

PC450-6 Serial No.: 12001 – 12143

- Carry out installation in the reverse order to removal.

※ I

★ Assemble the center swivel as shown in the diagram below.

- **Refilling with oil (hydraulic tank)**

★ Add oil through the oil filler to the specified level.

Run the engine to circulate the oil through the system. Then check the oil level again.

- **Bleeding air**

★ Bleed the air from the travel motor.
For details, see TESTING AND ADJUSTING, Bleeding air.

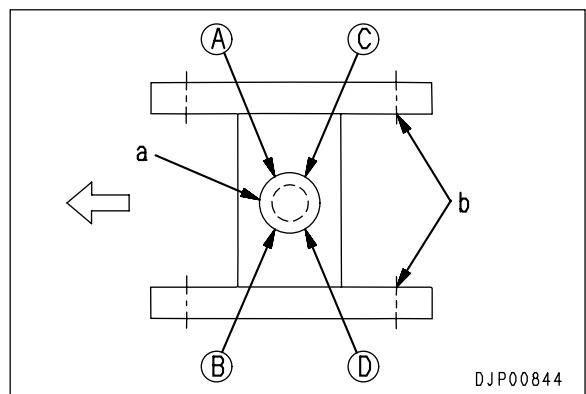
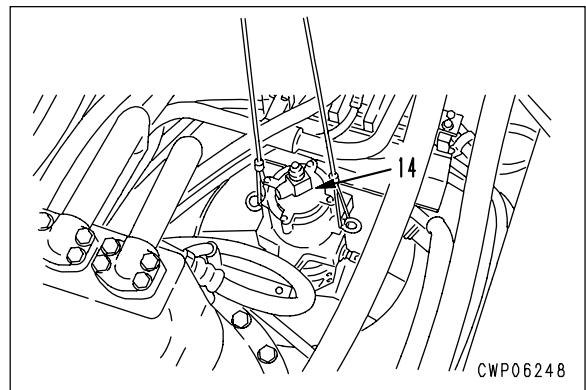

a: Center swivel
b: Sprocket

3. No. 2 carrier assembly

1) Assemble No. 2 carrier assembly as follows.

- ★ There are the remains of the caulking when the pin is inserted at the end face of hole **h** at the side of the carrier, so remove the caulked metal from the inside diameter of the hole before starting to assemble.
- i) Assemble bearing (21) to gear (20), fit top and bottom thrust washers (19) and (22), and set gear assembly in carrier (18).
- ii) Align with position of pin holes of shaft and carrier, then tap with a plastic hammer to install shaft (17).
 - ★ When installing the shaft, rotate the planetary gear, and be careful not to damage the thrust washer.
- iii) Insert pin (16).
 - ★ After inserting the pin, caulk the pin portion of the carrier.
- ★ After assembling the carrier assembly, check that gear (20) rotates smoothly.

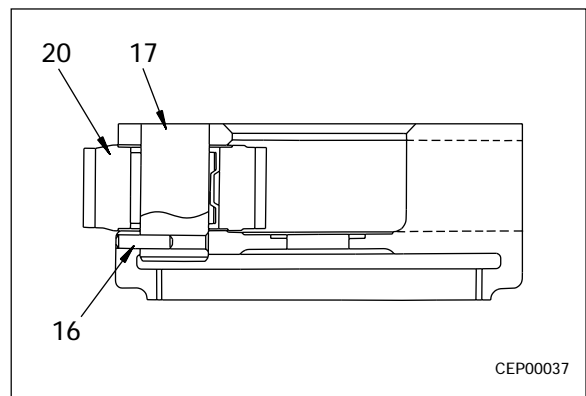
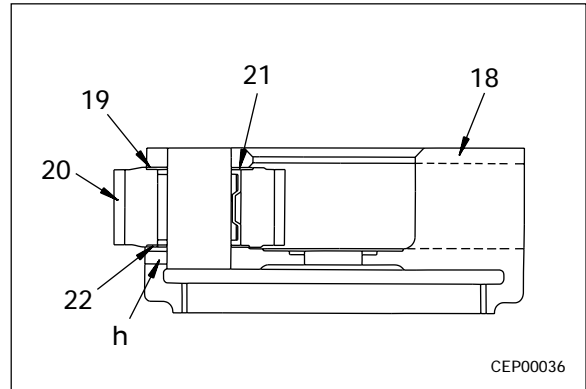

2) Install No. 2 carrier assembly (15).

- ★ Align the position so that the four tips of the gear shafts of carrier assembly (15) enter the four hollows in the end face of the motor case, then install.

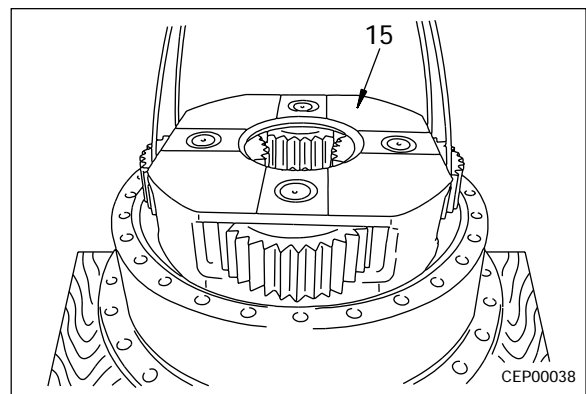

4. Ring gear

Lift ring gear (12) and install.

- ★ Assemble an O-ring to the face mating with the hub assembly.
- ★ Remove all grease and oil from the mating surface of the ring gear and hub.
- ★ Do not put any gasket sealant on the mating surface of the ring gear and hub under any circumstances.

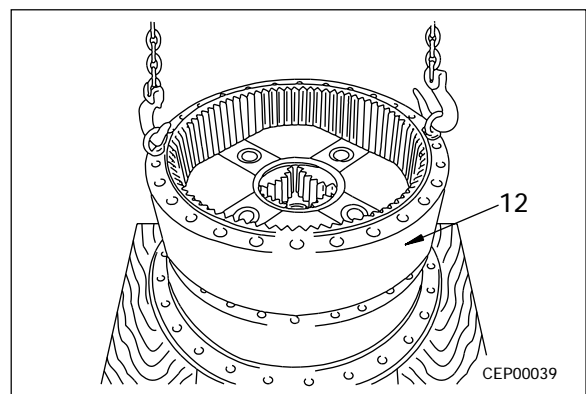

3. Shaft, center shaft, cylinder block

- 1) Set center shaft (35) and pistons (36) in position on retainer (34), then install drive shaft (43).

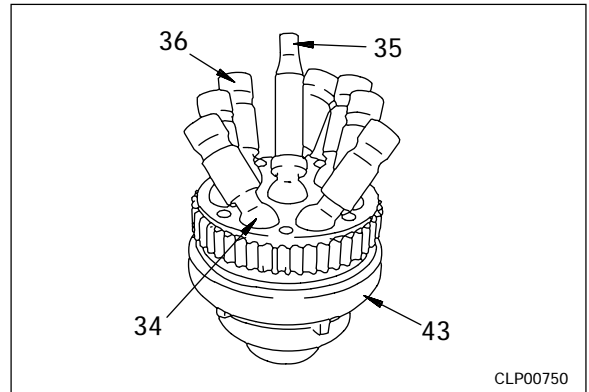

- 2) Using tool **S27**, tighten mounting screws.
 - ★ Replace the mounting screws with new parts.

 Mounting screw :

Thread tightener (LT-2)

 **kgm** Mounting screw:

1st step :

Max. 0.98 Nm {0.1 kgm}

2nd step:

7.8 – 9.8 Nm {0.8 – 1.0 kgm}

3rd step:

24.5 ± 1.9 Nm {2.5 ± 0.2 kgm}

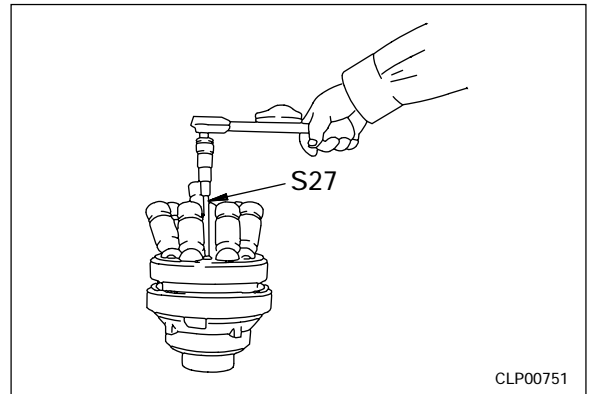

- ★ Order for tightening: ①-④-⑦-③-⑥-②-⑤
- ★ Tighten in three steps as shown above.
- ★ After tightening, wipe off any adhesive that has been squeezed out.
- ★ Check that the large ball of the piston and the center shaft move smoothly.

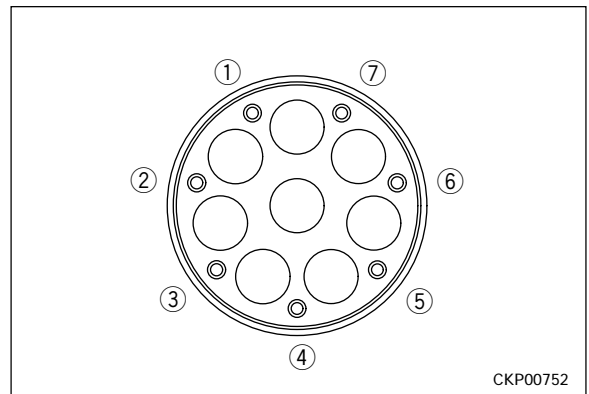

- 3) Measure play of piston (36) in axial direction.

- ★ Standard play of piston in axial direction: Max. 0.35 mm

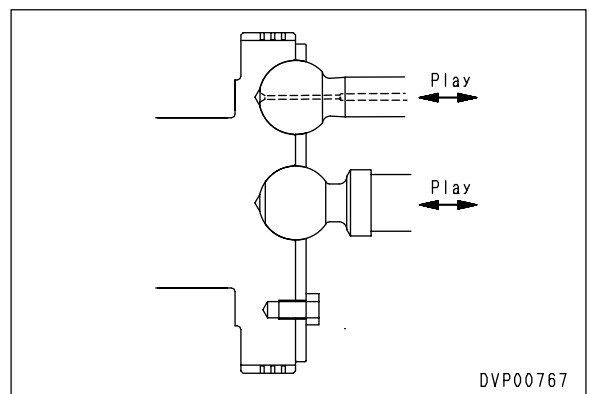

REMOVAL OF SWING MOTOR ASSEMBLY

- ⚠ Release the remaining pressure in the hydraulic circuit.
For details, see TESTING AND ADJUSTING, Releasing remaining pressure from hydraulic circuit.
- ⚠ Loosen the oil filler cap slowly to release the pressure inside the hydraulic tank.
- ★ Fit blind plugs in the disconnected hoses and tubes.
- 1. Disconnect suction hose (1).
- 2. Disconnect swing hoses (2).
- 3. Disconnect drain hoses (3) and (4).
- 4. Disconnect swing holding brake hose (5).
- 5. Remove mounting bolts, and lift off swing motor assembly (6).



Swing motor assembly: **110 kg**

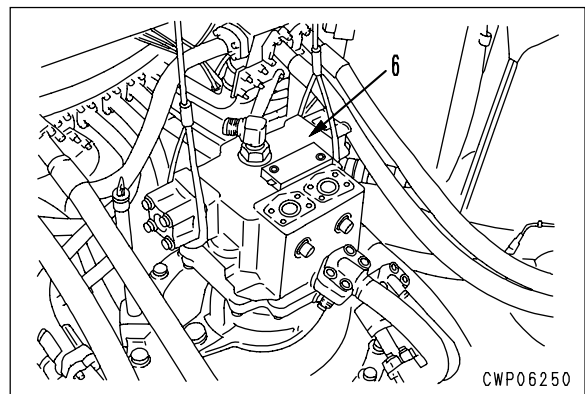
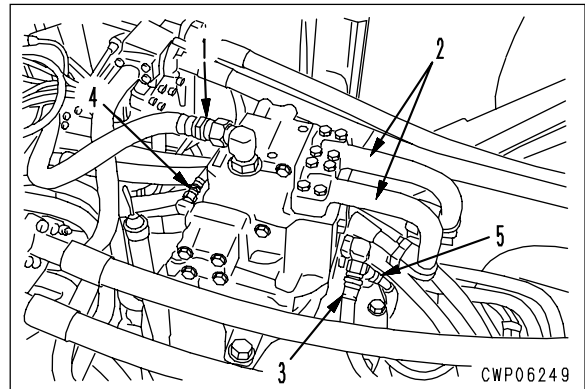

INSTALLATION OF SWING MOTOR ASSEMBLY

- Carry out installation in the reverse order to removal.
- **Refilling with oil (hydraulic tank).**
 - ★ Add oil through the oil filler to the specified level.
Run the engine to circulate the oil through the system. Then check the oil level again.
- **Bleeding air**
 - ★ Bleed the air from the swing motor.
For details, see TESTING AND ADJUSTING, Bleeding air.

11. Cover

Install cover (1).

 Cover mounting surface:

Gasket sealant (LG-6)

 **kgm** Mounting bolt: 1st pass: **98.1 Nm {10 kgm}**
2nd pass: **120 ± 5°**

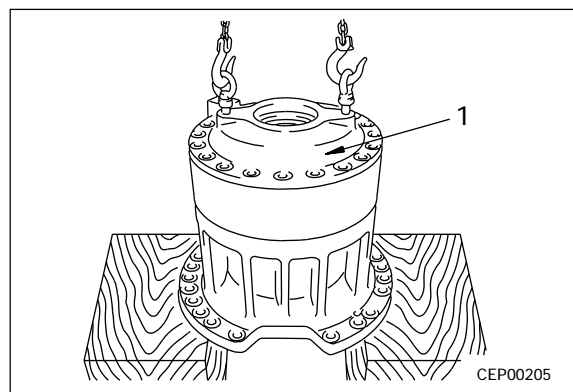
**12. Refilling with oil**

Tighten drain plug and add engine oil through oil filler.



Swing machinery case: **Approx. 21.5 ℓ**

REMOVAL OF TRACK ROLLER ASSEMBLY

1. Lower work equipment to ground, then loosen lubricator (1), and relieve track tension. ※ 1
 ⚠ The adjustment cylinder is under extremely high pressure, so never loosen the lubricator more than one turn. If the grease does not come out easily, move the machine backwards and forwards.

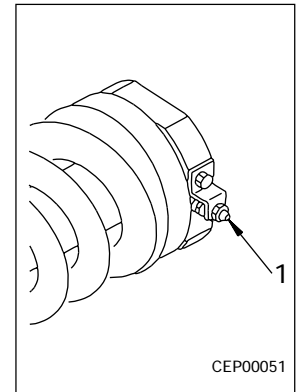
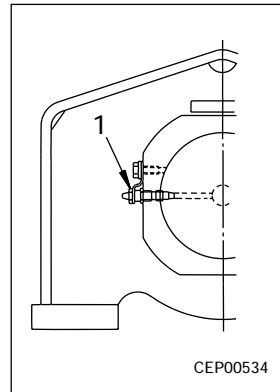

2. Remove mounting bolts of track roller guard (2), then swing work equipment 90°, jack up machine with work equipment, and remove track roller guard (2) towards outside of machine. ※ 2



Track roller guard: **Approx. 45 kg**

3. Lower chassis completely, remove mounting bolts of track roller assembly (3), then jack up machine with work equipment, and remove track roller assembly (3) to outside of machine. ※ 3



Track roller assembly: **Approx. 75 kg**

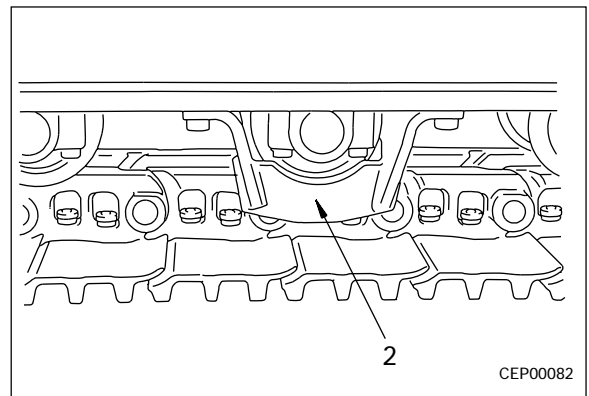



INSTALLATION OF TRACK ROLLER ASSEMBLY

- Carry out installation in the reverse order to removal.



※ 1

- ★ Adjust the track tension.
 For details, see TESTING AND ADJUSTING, Testing and adjusting track tension.

※ 2

-  Roller guard mounting bolt:
Thread tightener (LT-2)
 Roller guard mounting bolt:
926.8 ± 102.9 Nm {94.5 ± 10.5 kgm}

※ 3

-  Track roller assembly mounting bolt:
Thread tightener (LT-2)
 Track roller assembly mounting bolt:
 1st pass: **196.0 ± 19.6 Nm {20 ± 2 kgm}**
 2nd pass:
Tighten an additional 105 ± 5°

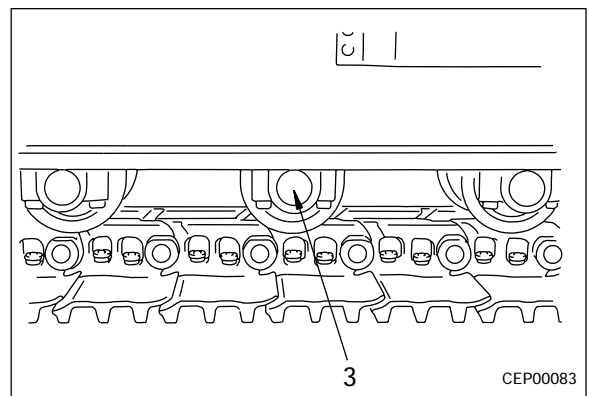

REMOVAL OF HYDRAULIC TANK ASSEMBLY

- Swing the upper structure to set the position of the hydraulic tank drain and mounting bolt outside the track.

⚠ Loosen the hydraulic tank oil filler cap slowly to release the pressure inside the hydraulic tank.

1. Drain oil from hydraulic tank.



Hydraulic tank: **Approx. 270 ℓ**

2. Remove operator's cab assembly.
For details, see REMOVAL OF OPERATOR'S CAB ASSEMBLY.
3. Remove control valve top cover, hydraulic tank undercover, and main pump undercover.
4. Open main pump side cover, then remove partitions (1) and (2).
5. Remove covers (3) and (4).
6. Remove air conditioner air suction port (5).

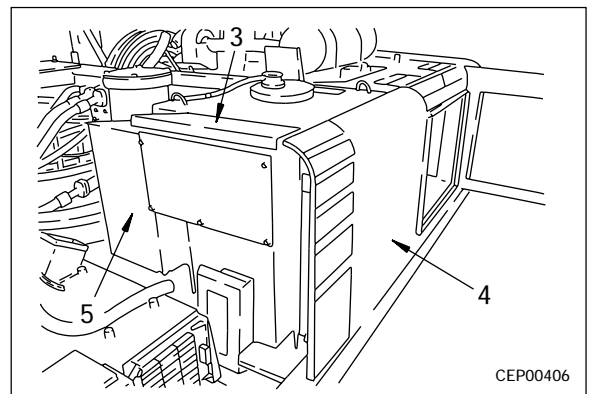
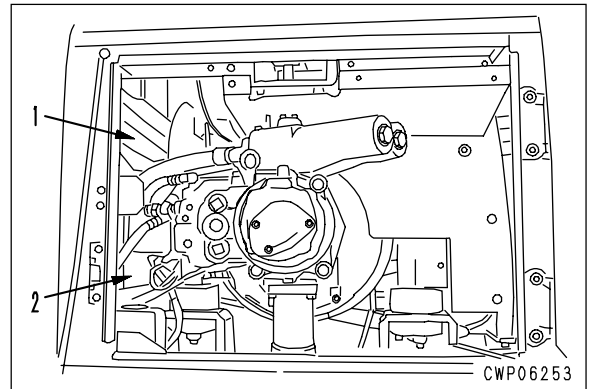

7. Disconnect drain hoses (6), (7), and (8).

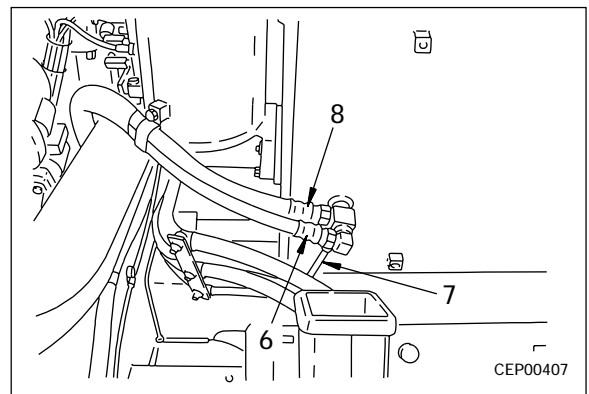

8. Disconnect hydraulic oil filter inlet hose (9) and outlet hose (10).

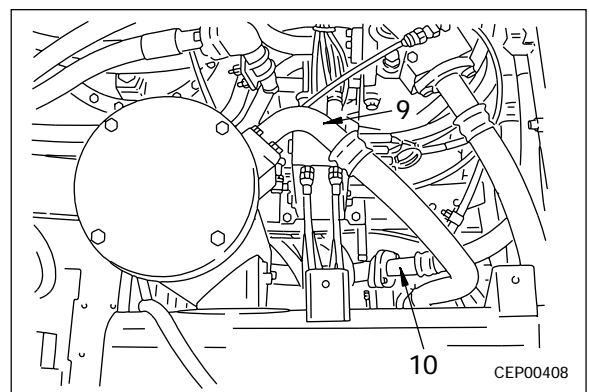

ASSEMBLY OF MAIN PUMP ASSEMBLY

★ Clean all parts, remove all burrs, and check for dirt or damage. Coat the rotating and sliding surfaces of all parts with engine oil (EO10-CD) before installing.

Always check the following parts before assembling.

- i) Check contact of cradle and rocker cam (for details, see procedure for checking contact).
- ii) Check contact between cylinder block and valve plate (for details, see procedure for checking contact).
- iii) Check contact between valve plate and end cap (for details, see procedure for checking contact).

• **Assembly of front pump assembly**

1. Shaft, cradle assembly

• **Assembly of shaft and cradle assembly**

- 1) Assemble flange ring to shaft (68), then use tool **S7** to press fit bearing (72).

 Press-fitting surface of bearing:
Grease (G2-LI)

★ When press fitting the bearing, push the end face of the bearing inner race with tool **S7**.

- 2) Assemble washer (71), and install snap ring (70).

• **Method of selecting lock washer (71)**

- i) After press fitting bearing (72) to shaft (68), assemble washer (71) (removed during disassembly).
- ii) Measure clearance dimension "a" between end face of assembled washer (71) and snap ring groove.

★ Clearance dimension "a":
1.45 – 1.60 mm

- iii) If clearance "a" is not within above standard value, select washer from table below and assemble.

Washer Part No.	708-17-12750	708-17-12760	708-17-12770
Washer thickness (mm)	3.0	3.1	3.2

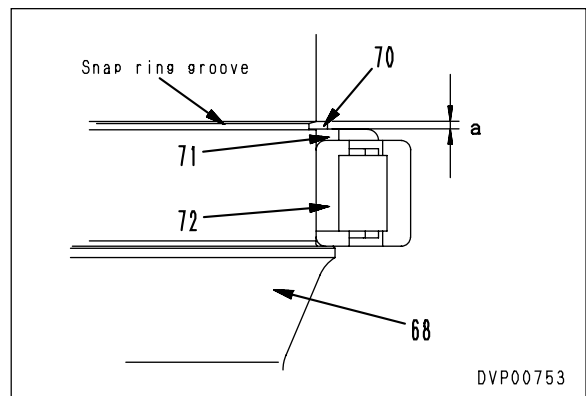
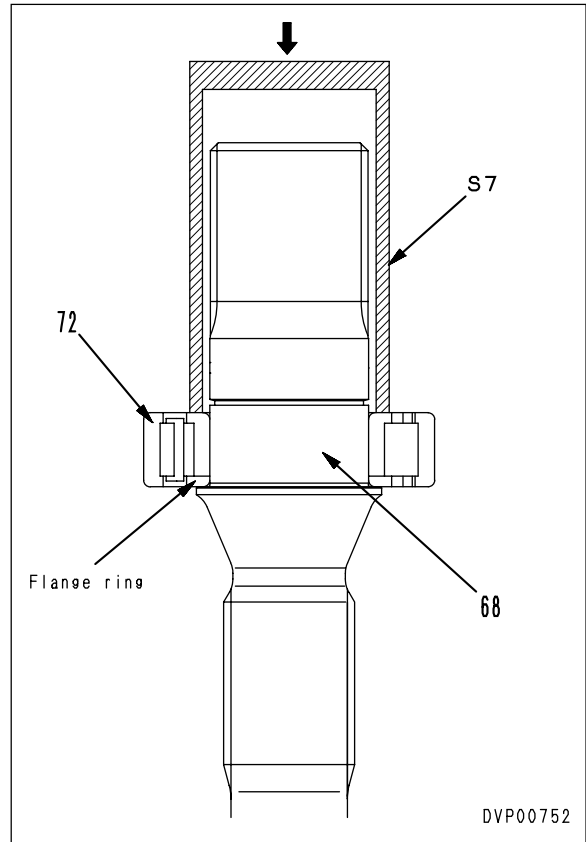

- 3) Assemble impeller assembly inside end cap (35).

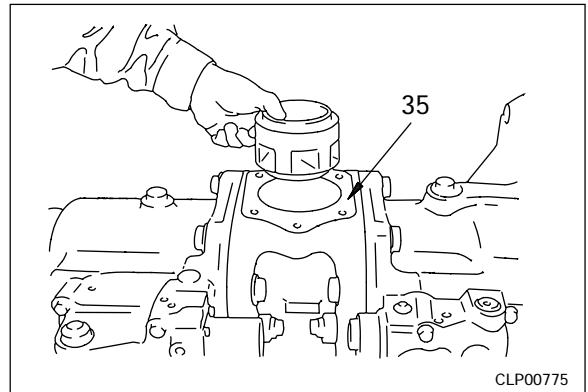

- 4) Positioning impeller assembly
 - i) Install cover (43) to end cap.
 - ★ Do not install the O-ring.
 - ii) Measure clearance **a** between end cap (35) and cover (43).
 - ★ Measure at 3 places around the circumference of the cover and take the average.
 - iii) Select shim (44) from table below to make thickness of $(a+0.1)$ to $(a+0.2)$, then install.

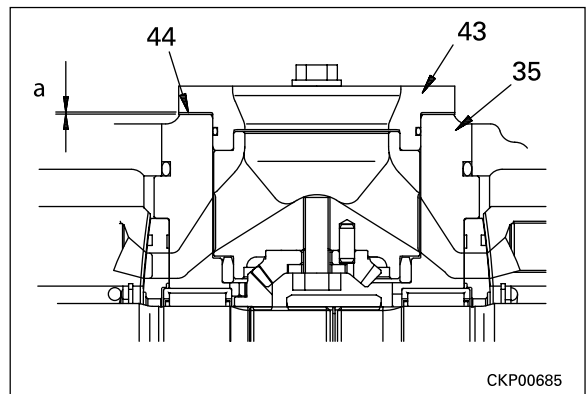

Part No.	708-2H-21710	708-2H-21720	708-2H-21730
Shim thickness (mm)	0.1	0.2	0.5

- iv) Fit O-ring to cover (43), then assemble selected shim (44) and install.

kgm Mounting bolt:
110.3 ± 12.3 Nm {11.25 ± 1.25 kgm}

22. Measuring rotating torque of pump assembly

- 1) Set tool **S10** to pump shaft.
- 2) Set torque wrench to tool **S10**, rotate shaft at low speed (3 – 5 sec/1 turn) and measure rotating torque.
 - ★ When checking the rotating torque, check that the shaft rotates smoothly without any variation.
 - Variation range:
Max. 2.9 Nm {0.3 kgm}
 - Rotating torque:
Max. 4.9 Nm {5.0 kgm}
 - ★ If there is any abnormality in the rotating torque, disassemble and adjust again.

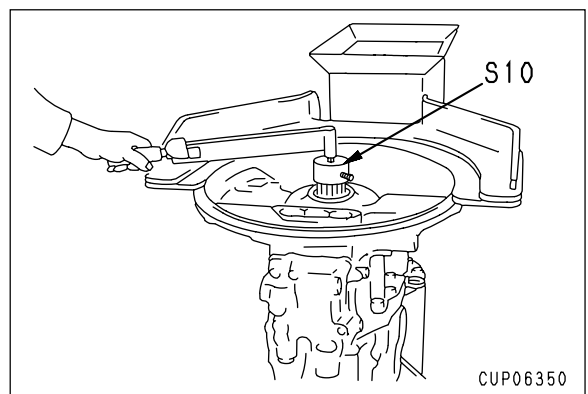

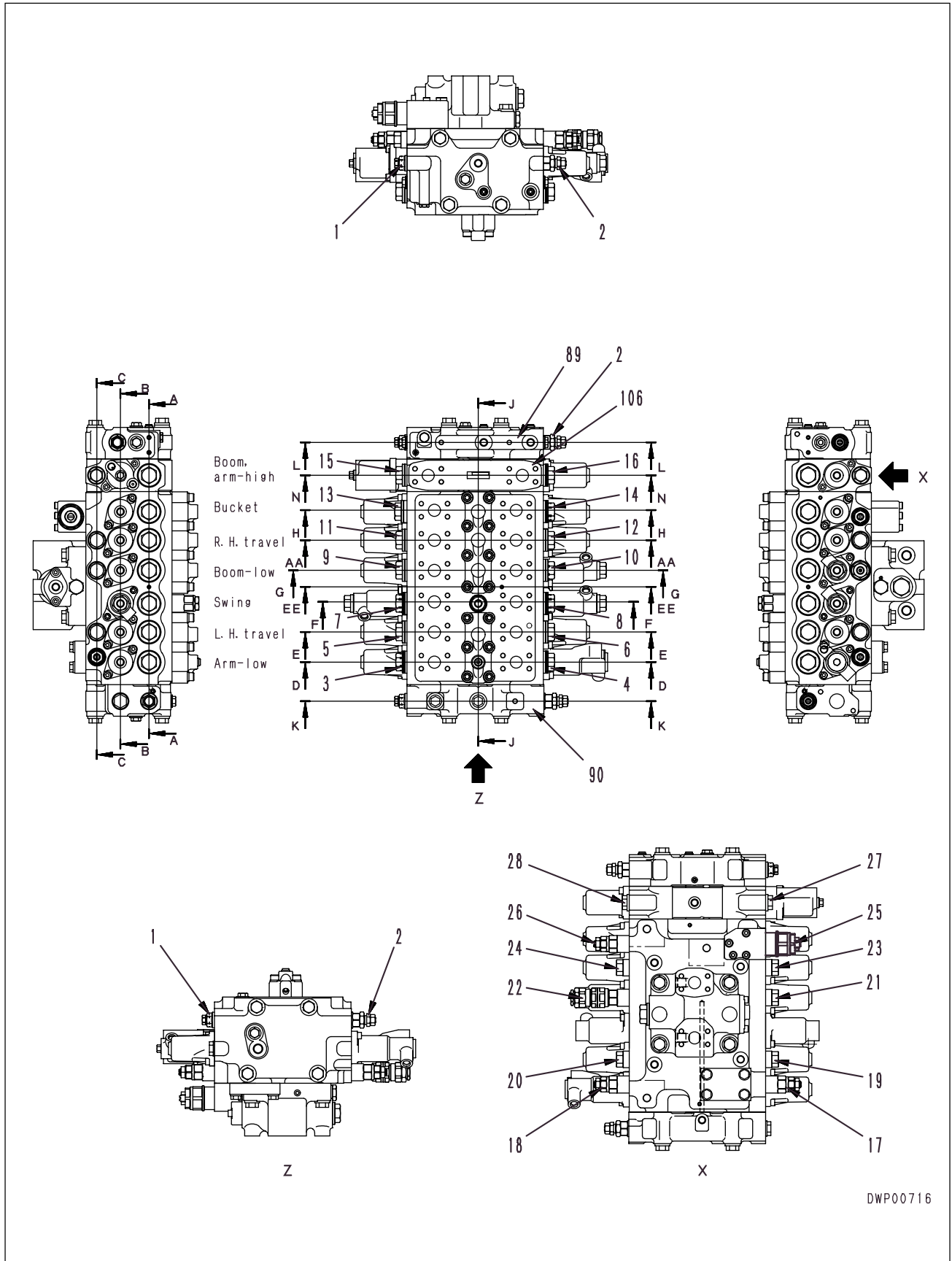

DISASSEMBLY OF CONTROL VALVE ASSEMBLY

(1/3)





DWP00716



3. Bucket control valve

- 1) Assemble spool assembly (84) to valve body.
- 2) Assemble retainer (83) and spring (82), then fit O-ring to case (81) and install.
 Case mounting bolt:
30.9 ± 3.4 Nm {3.15 ± 0.35 kgm}
- 3) Assemble retainer (80) and spring (79), then fit O-ring to case (78) and install.
 Case mounting bolt:
30.9 ± 3.4 Nm {3.15 ± 0.35 kgm}





4. Boom control valve

- 1) Assemble spool assembly (77) to valve body.
- 2) Assemble retainer (76) and spring (75), then fit O-ring to case (74) and install.
 Case mounting bolt:
30.9 ± 3.4 Nm {3.15 ± 0.35 kgm}
- 3) Assemble spring (73) and piston (72), and install plug (71).
 Plug:
107.8 ± 14.7 Nm {11.0 ± 1.5 kgm}
- 4) Assemble retainer (70) and spring (69), then fit O-ring to case (68) and install.
 Case mounting bolt:
30.9 ± 3.4 Nm {3.15 ± 0.35 kgm}



5. R.H. travel control valve, L.H. travel control valve

- 1) Assemble spool assembly (67) to valve body.
- 2) Assemble retainer (66) and spring (65), then fit O-ring to case (64) and install.
 Case mounting bolt:
30.9 ± 3.4 Nm {3.15 ± 0.35 kgm}
- 3) Assemble retainer (63) and spring (62), then fit O-ring to case (61) and install.
 Case mounting bolt:
30.9 ± 3.4 Nm {3.15 ± 0.35 kgm}

6. Swing control valve

- 1) Assemble spool assembly (60) to valve body.
- 2) Assemble piston (59), and install plug (58).
 Plug:
107.8 ± 14.7 Nm {11.0 ± 1.5 kgm}
- 3) Assemble retainer (57) and spring (56), then fit O-ring to case (55) and install.
 Case mounting bolt:
30.9 ± 3.4 Nm {3.15 ± 0.35 kgm}
- 4) Assemble piston (54), and install plug (53).
 Plug:
107.8 ± 14.7 Nm {11.0 ± 1.5 kgm}
- 5) Assemble retainer (52) and spring (51), then fit O-ring to case (50) and install.
 Case mounting bolt:
30.9 ± 3.4 Nm {3.15 ± 0.35 kgm}

7. Arm control valve

- 1) Assemble spool assembly (49) to valve body.
- 2) Assemble retainer (48) and spring (47), then fit O-ring to case (46) and install.
 Case mounting bolt:
30.9 ± 3.4 Nm {3.15 ± 0.35 kgm}
- 3) Assemble retainer (45) and spring (44), then fit O-ring to case (43) and install.
 Case mounting bolt:
30.9 ± 3.4 Nm {3.15 ± 0.35 kgm}
- 4) Assemble spring (41) and piston (42), and install plug (40).
 Plug:
107.8 ± 14.7 Nm {11.0 ± 1.5 kgm}

DISASSEMBLY OF WORK EQUIPMENT PPC VALVE ASSEMBLY

1. Remove nut (1), then remove disc (2) and boot (3).
2. Remove bolts, then remove plate (5).
 - ★ Do not remove joint (4) unless it is to be replaced.
3. Remove seal (6) and collar (7).
4. Pull out piston (8), and remove retainer (9), springs (10) and (11), and shim (12).
 - ★ Spring (10) consists of two springs each of two types with different installed loads, so check the mounting position (hydraulic port) and mark with tags to prevent mistakes when installing.
5. Pull out valve (13) from body (14).

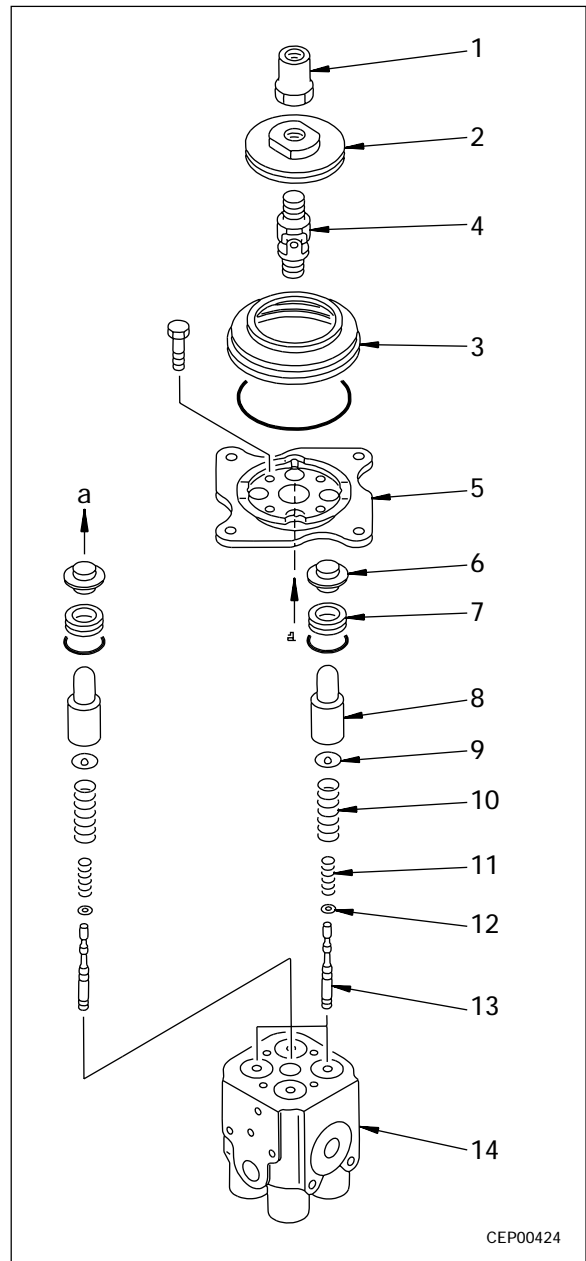

INSTALLATION OF BOOM CYLINDER ASSEMBLY

- Carry out installation in the reverse order to removal.

※ 1

- ★ When tightening the locknut, tighten so that the clearance between the plate and nut is 0.5 – 1.5 mm.

※ 2

- Inside surface of bushing when assembling pin: **Anti-friction compound (LM-P)**
- Greasing after assembling pin: **Grease (LM-G)**

- ⚠ When aligning the position of the pin hole, never insert your fingers in the pin hole.
- ★ Adjust the shim thickness so that the clearance between the end face of the rod of cylinder (2) and plate (4) is less than 1.0 mm.
 - Standard shim thickness: 1.0 mm, 1.5 mm

※ 3

- Inside surface of bushing when assembling pin: **Anti-friction compound (LM-P)**
- Greasing after assembling pin: **Grease (LM-G)**

- ⚠ When aligning the position of the pin hole, never insert your fingers in the pin hole.
- ★ Adjust the shim thickness so that the clearance between the end face of the bottom of cylinder (2) and bracket (8) is less than 1.0 mm.
 - Standard shim thickness: 1.0 mm, 1.5 mm

- **Bleeding air**
 - ★ Bleed the air. For details, see TESTING AND ADJUSTING, Bleeding air.
- **Refilling with oil (hydraulic tank)**
 - ★ Add oil through the oil filler to the specified level. Run the engine to circulate the oil through the system. Then check the oil level again.

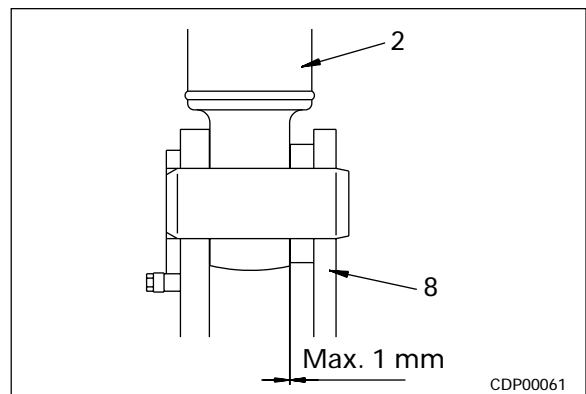
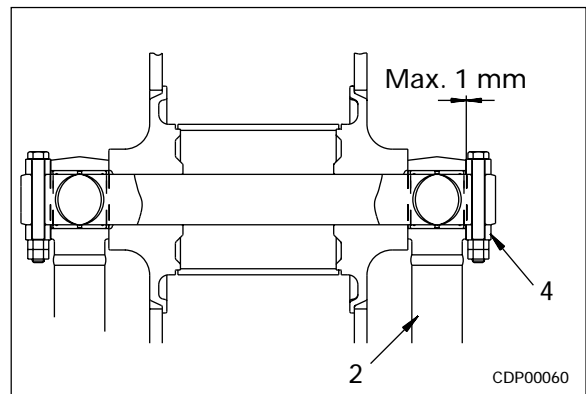
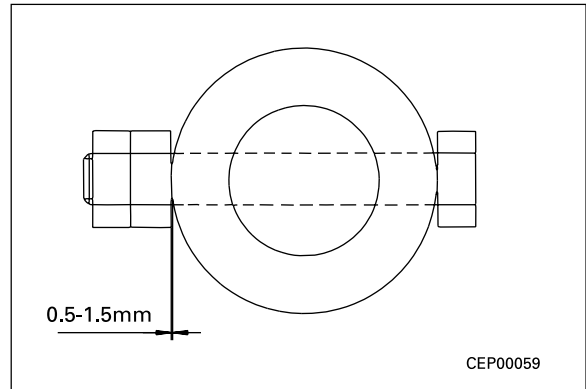

- iii) Caulk thread at 2 places with punch.
- When using a new part for either or both of rod or piston assembly (2)
 - ★ For the rod with bottom cushion, mark the cushion plug position on the end face of the rod.
 - Arm cylinder only

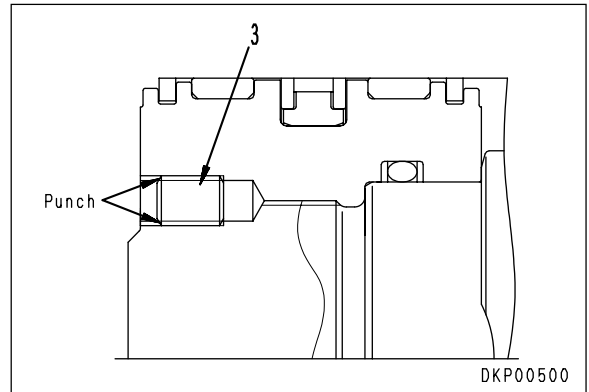

- i) Screw in until piston assembly (4) contacts end face of rod, then use tool U6 to tighten.

 Piston assembly (4):
 $294 \pm 29.4 \text{ Nm}$ { $30 \pm 3.0 \text{ kgm}$ }

- ★ After tightening the piston, check that there is play in plunger (5).
- Boom, arm cylinder only

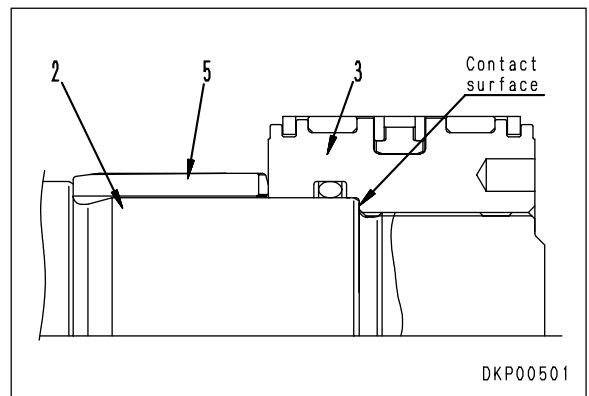

- ii) Machine one hole used to install screw (3).

- ★ Align a drill horizontal with the V-groove of the thread of rod (2) and piston (4), then carry out machining.
- ★ For the cylinder with bottom cushion (arm cylinder), avoid the cushion plug position when machining.

- Screw machining dimension (mm)

Drill diameter	Bottom hole depth	Tap used	Tap depth
10.3	27	12×1.75	20

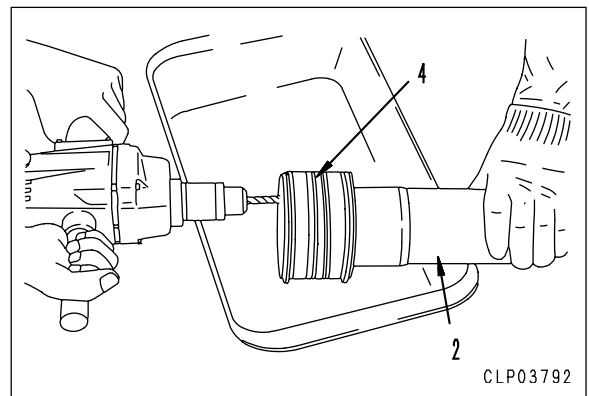

- iii) After machining, wash thoroughly to remove all metal particles and dust.

- iv) Tighten screw (3).

 Screw (3):
 $66.2 \pm 7.35 \text{ Nm}$ { $6.75 \pm 0.75 \text{ kgm}$ }

- v) Caulk thread at 2 places with punch.

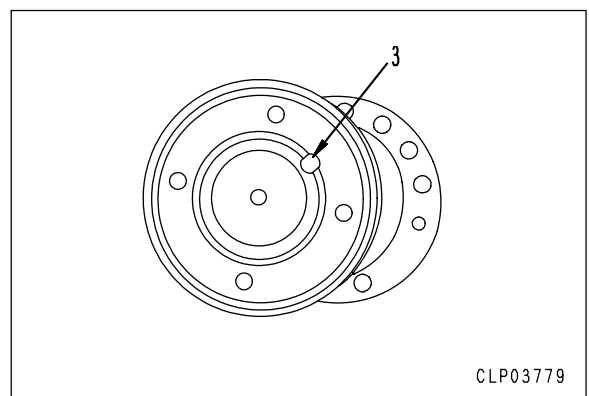

REMOVAL OF BOOM ASSEMBLY

1. Remove bucket and arm assembly
For details, see REMOVAL OF BUCKET, ARM ASSEMBLY.
 ⚠ Lower the boom assembly completely to the ground, and set the safety lock lever to the LOCK position.
2. Disconnect grease hose (1).
3. Sling boom cylinder assembly (2), and remove lock bolt (3). ※ 1
4. Remove plate (4), then remove head pin (5). ※ 2
 - ★ There are shims installed, so check the number and thickness, and keep in a safe place.
5. Start engine, and retract piston rod, then tie piston rod with wire to prevent it from coming out, and lower it onto stand.
 - ★ Disconnect the boom cylinder on the opposite side in the same way.
 - ⚠ Release the remaining pressure in the hydraulic circuit.
For details, see TESTING AND ADJUSTING, Releasing remaining pressure in hydraulic circuit.
6. Disconnect arm cylinder hoses (6) and bucket cylinder hoses (7), and secure to valve with rope.
7. Disconnect wiring connector (8) for working lamp.
8. Remove plate, and set tool **V** to boom foot pin (9).
9. Raise boom assembly (10), remove boom foot pin (9) using tool **V**, then remove boom assembly (10). ※ 3
 - ★ There are shims installed, so check the number and thickness, and keep in a safe place.



Boom assembly: **3950 kg**

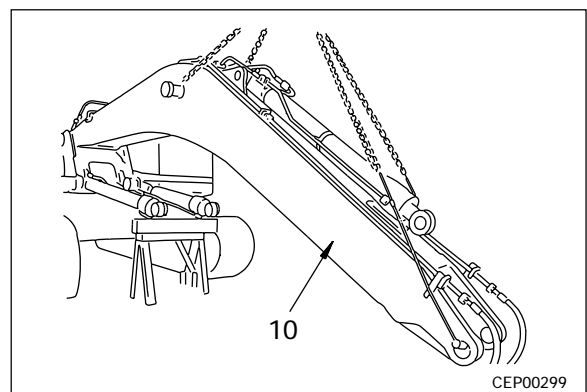
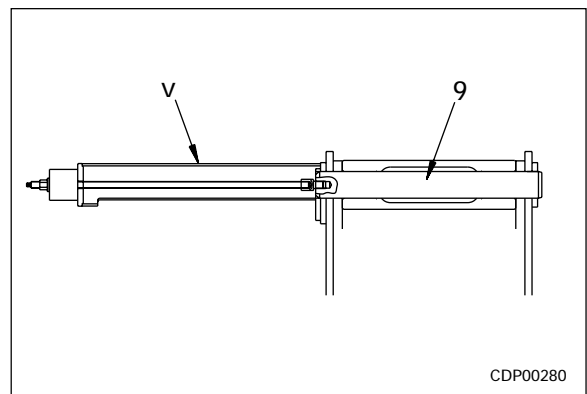
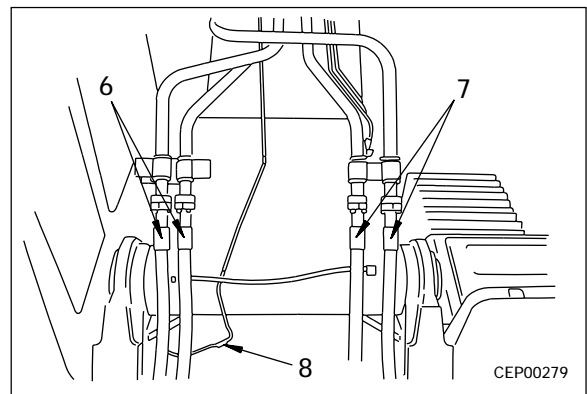
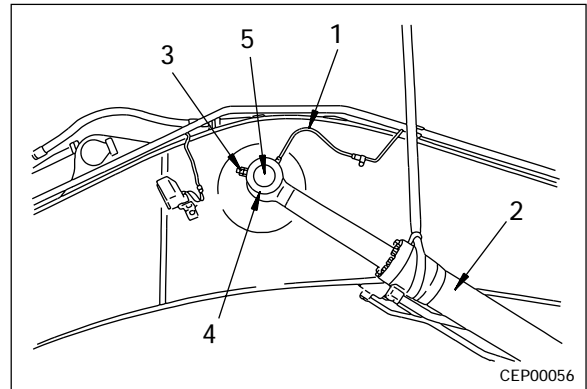

REMOVAL OF GOVERNOR, PUMP CONTROLLER ASSEMBLY

⚠ Disconnect the cable from the negative (-) terminal of the battery.

1. Remove Radio (2) if fitted.
2. Remove plate (1), then remove cover (2), (3).
3. Lift cover (3) away carefully to locate speaker harness connector. Disconnect and remove panel completely.

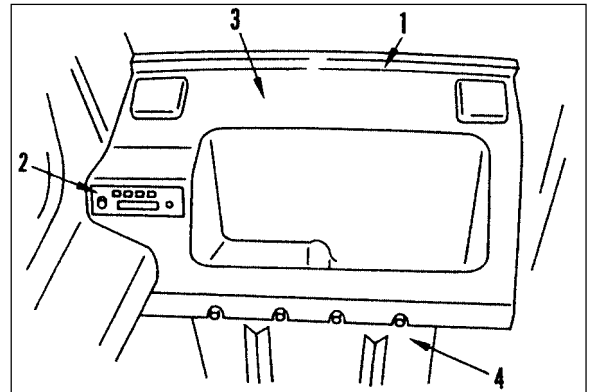

4. Remove divider board (5).
5. Remove 5 connectors (5).
6. Remove engine throttle and pump controller **※ 1** assembly (6).

Installation

- Carry out installation in the reverse order to removal.
※ 1
- ★ Check the performance of the work equipment, travel, and swing. For details, see TESTING AND ADJUSTING.

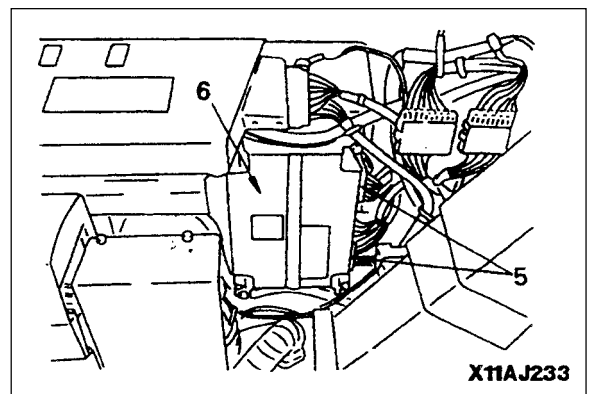

X11AJ233

PC400-6 Serial No.: 32250 and up
 PC450-6 Serial No.: 12144 and up

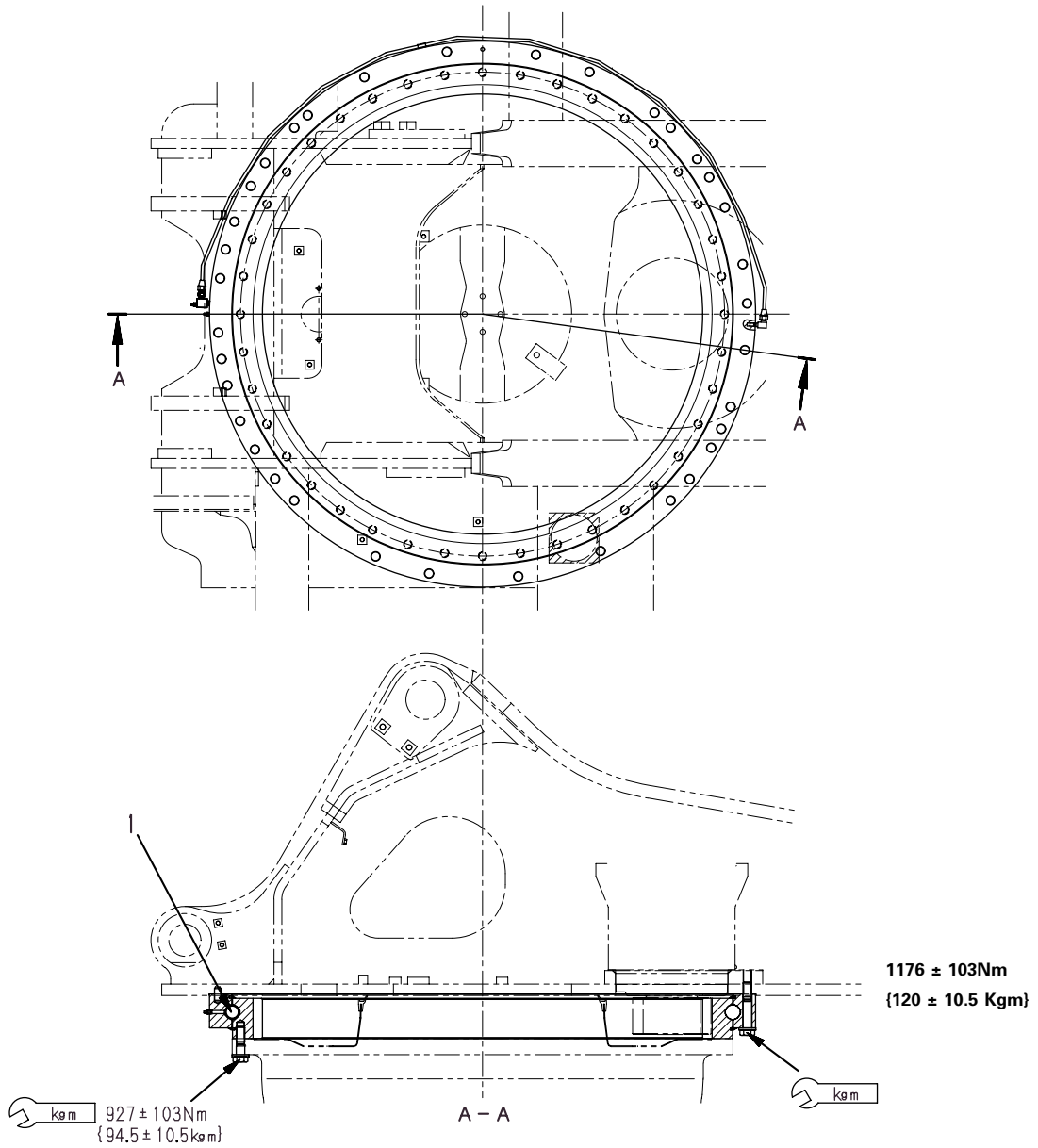

Unit: mm

No.	Check item	Criteria		Remedy
		Standard clearance	Clearance limit	
1	Clearance of bearing in axial direction (when mounted on machine)	0.5 – 1.6	3.2	Replace

Unit: mm

No.	Check item	Criteria		Remedy	
1	Link pitch	Standard size	Repair limit		
		228.9	231.9		
2	Bushing outside diameter	Standard size	When turned		Reverse or replace
			Normal load	Impact load	
		71.5	—	66.5	
3	Link height	Standard size	Repair limit		Repair or replace
		129	119		
4	Thickness of link metal (bushing press-fitting portion)	34.5		Replace	
5	Shoe bolt pitch	184			
6		76.2			
7		20			
8	Link	Inside width	106		Repair or replace
9		Overall width	51.6		
10		Tread width	44.5		
11	Protrusion of pin	4.4		Adjust or replace	
12	Protrusion of regular bushing	5.25			
13	Overall length of pin	252			
14	Overall length of bushing	164.5			
15	Thickness of bushing metal	13.2			
16	Thickness of spacer	—			
17	Press-fitting force	Bushing	117.6 – 303.8 kN {12 – 31 ton}		—
18		Regular pin	186.2 – 460.6 kN {19 – 47 ton}		
*19		Master	137.2 – 284.2 kN {14 – 29 ton}		

* : Dry type track link

(6/6)

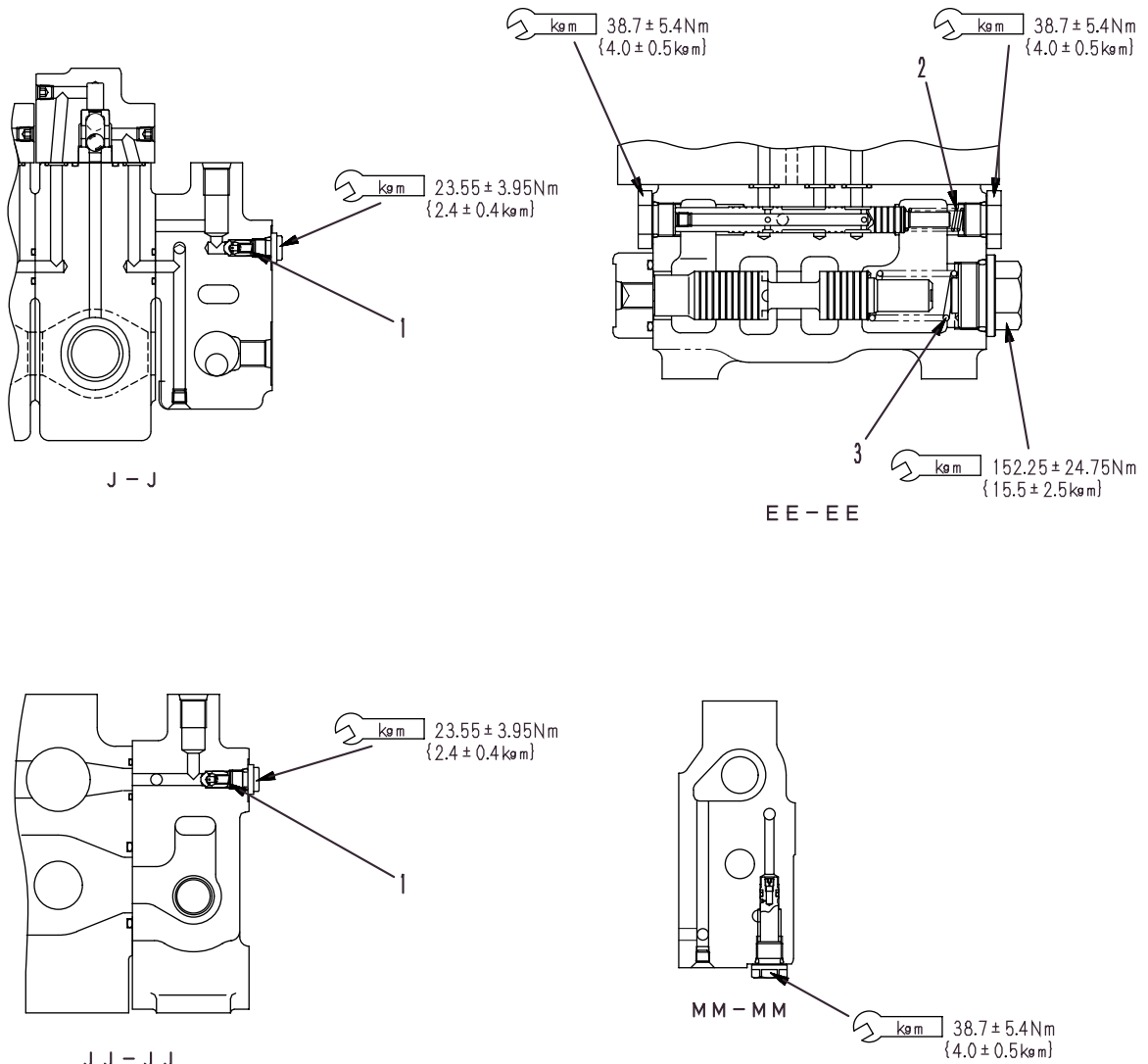

SWP05042

Unit: mm

No.	Check item	Criteria				Remedy	
		Standard size		Repair limit			
		Free length x O.D.	Installed length	Installed load	Free length	Installed load	
1	Check valve spring	11.5 x 4.6	8.5	1.5 N {0.15 kg}	—	1.2 N {0.12 kg}	Replace spring if there is damage or deformation
2	Spool return spring	65.5 x 27.2	50	167.6 N {17.1 kg}	—	134.3 N {13.7 kg}	
3	Spool return spring	13.6 x 5.5	10	2 N {0.2 kg}	—	1.5 N {0.15 kg}	

LS-EPC VALVE

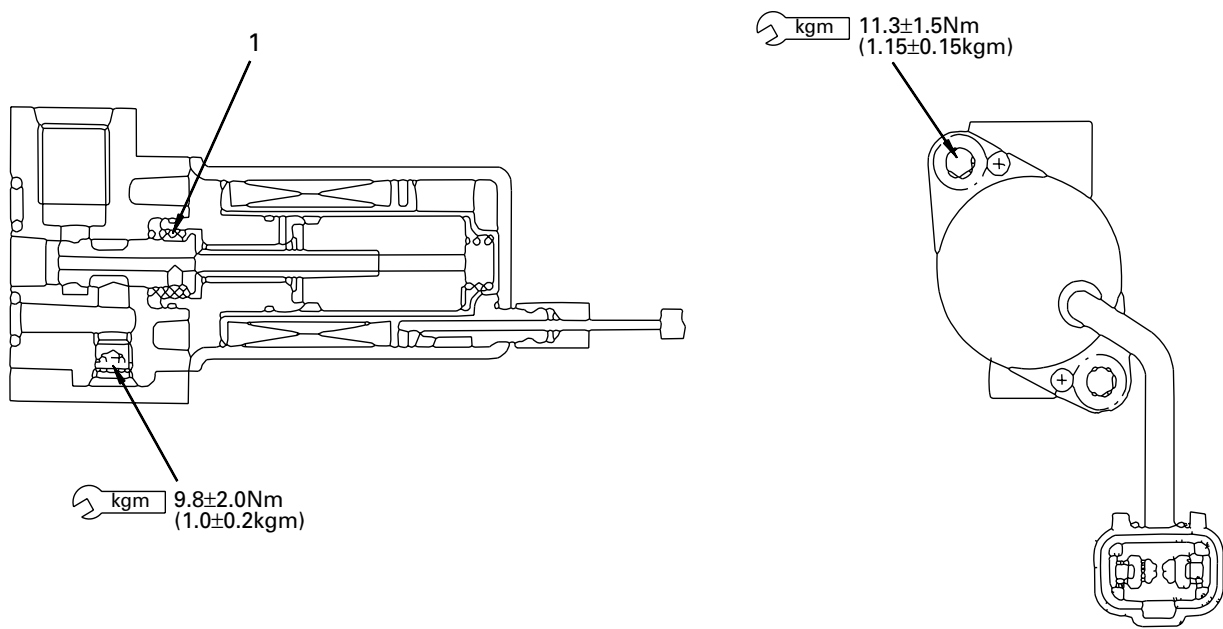

SBP00438

Unit: mm

No.	Check item	Criteria					Remedy
		Standard size			Repair limit		
		Free length x O.D.	Installed length	Installed load	Free length	Installed load	
1	Return spring	9.0 x 11.4	7.9	3.1 N {0.32 kg}	—	—	Replace EPC valve ass'y if any damages or deformations are found.

CLICK HERE TO **DOWNLOAD** THE COMPLETE MANUAL

- Thank you very much for reading the preview of the manual.
- You can download the complete manual from: www.heydownloads.com by clicking the link below



- Please note: If there is no response to CLICKING the link, please download this PDF first and then click on it.

CLICK HERE TO **DOWNLOAD** THE COMPLETE MANUAL